

DWG. NO. VM9962

REV	SH/DATE	DESCRIPTION	P.C.N.	BY	DATE	BY
1		RELEASE FOR PROTOTYPE	9004366	BS	20MAR02	EDICT
2		VM9961-2 WAS VM9961-1 (1) VM9959-2 WAS VM9959-1 (2) VM6992-B WAS VM6992-A (3)	9004406	BS	11APR02	EDICT
3		VM9961-3 WAS VM9962-1 (1) VM9959-3 WAS VM9959-2 (2)	9004438	BS	03MAY02	EDICT
4		VM9961-4 WAS VM9962-3 (1) VM9959-4 WAS VM9959-3 (2)	9004487	BS	06JUN02	EDICT
A		VM9961-A WAS VM9962-4 (1) VM9959-A WAS VM9959-4 (2) REVISE LABEL ARTWORK: REVISE AND REDRAWN DIM 8.0 [.315] WAS 6.0 [.237] RELEASE FOR PRODUCTION	65409	BS	20JUN02	EDICT

- NOTES:
1. REFERENCE IPC-A-610 FOR ASSEMBLY PRACTICES AND PROCEDURES, UNLESS OTHERWISE SPECIFIED.
 2. ASSEMBLER IS TO PRINT LABEL INFORMATION AS SHOWN, USING ADHESIVE LABEL (ITEM 5).
 3. PLACE LABEL (ITEM 5) ON OUTSIDE (OPPOSITE OF SIDE SHOWN) OF HOUSING (ITEM 3) AS INDICATED.
 4. PRINT JABIL PRODUCTION DATE IN JULIAN DATE CODE FORMAT AND SHIFT NUMBER AT LOCATION INDICATED.

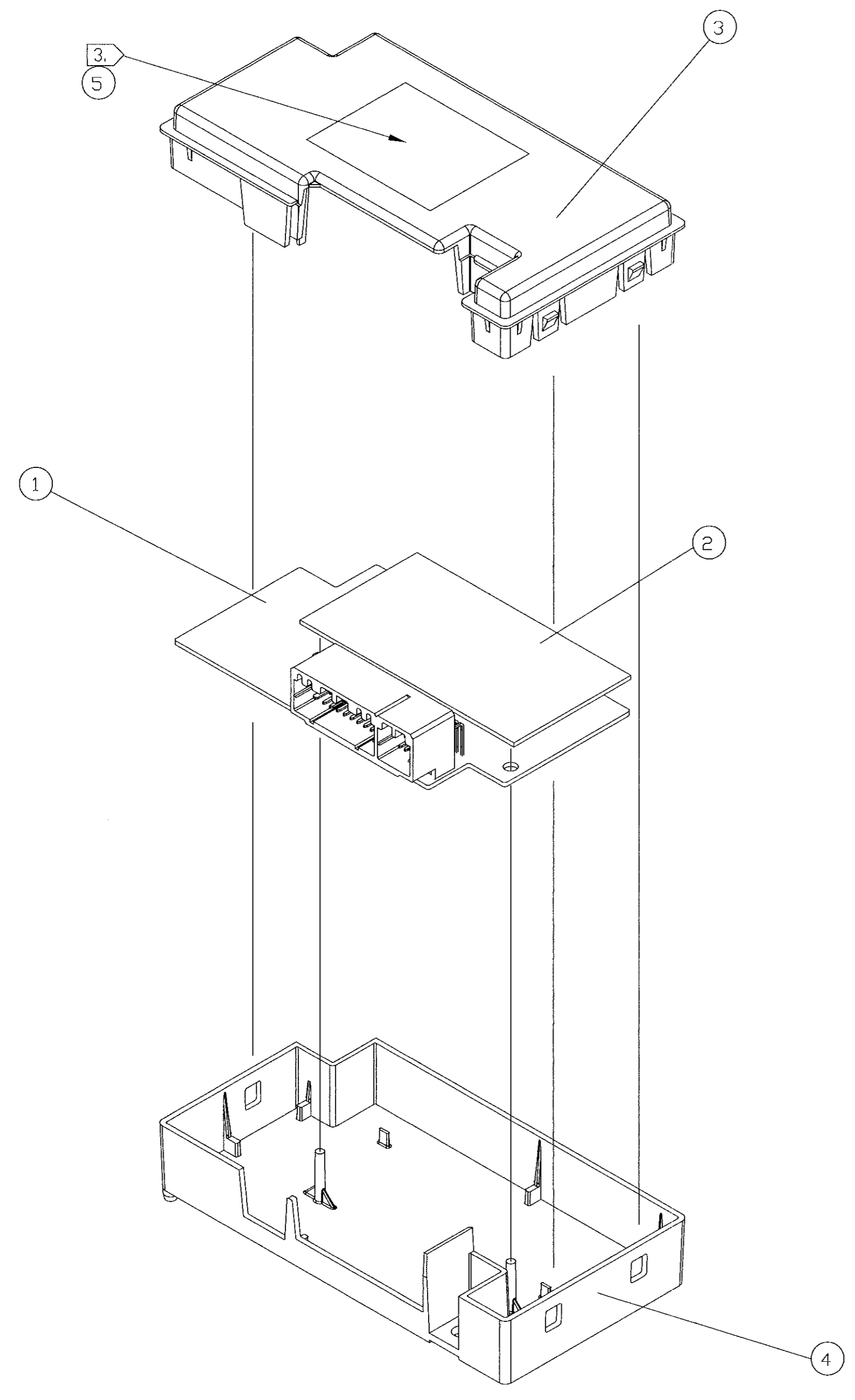

VIEW FOR REFERENCE ONLY

VM9962 A
03.5 CS ICELAND HFM

PRODUCT CODE
5G

MANUALLY ASSEMBLED PARTS:

LOCATION	DESCRIPTION	PART#	QTY	PACKAGE
1	PCB ASM 03.5 CS ICELAND HFM REV A	VM9961-A	1	TH_FAKEPART
2	PCB ASM 03.5 CS ICELAND HFM REV A	VM9959-A	1	TH_FAKEPART
3	HOUSING ICELAND HFM UPR	VM6992-B	1	TH_FAKEPART
3	HOUSING ICELAND HFM LWR	VM1784-A	1	TH_FAKEPART
5	LABEL STOCK, 2.0 X 3.0	VR1877	1	TH_FAKEPART

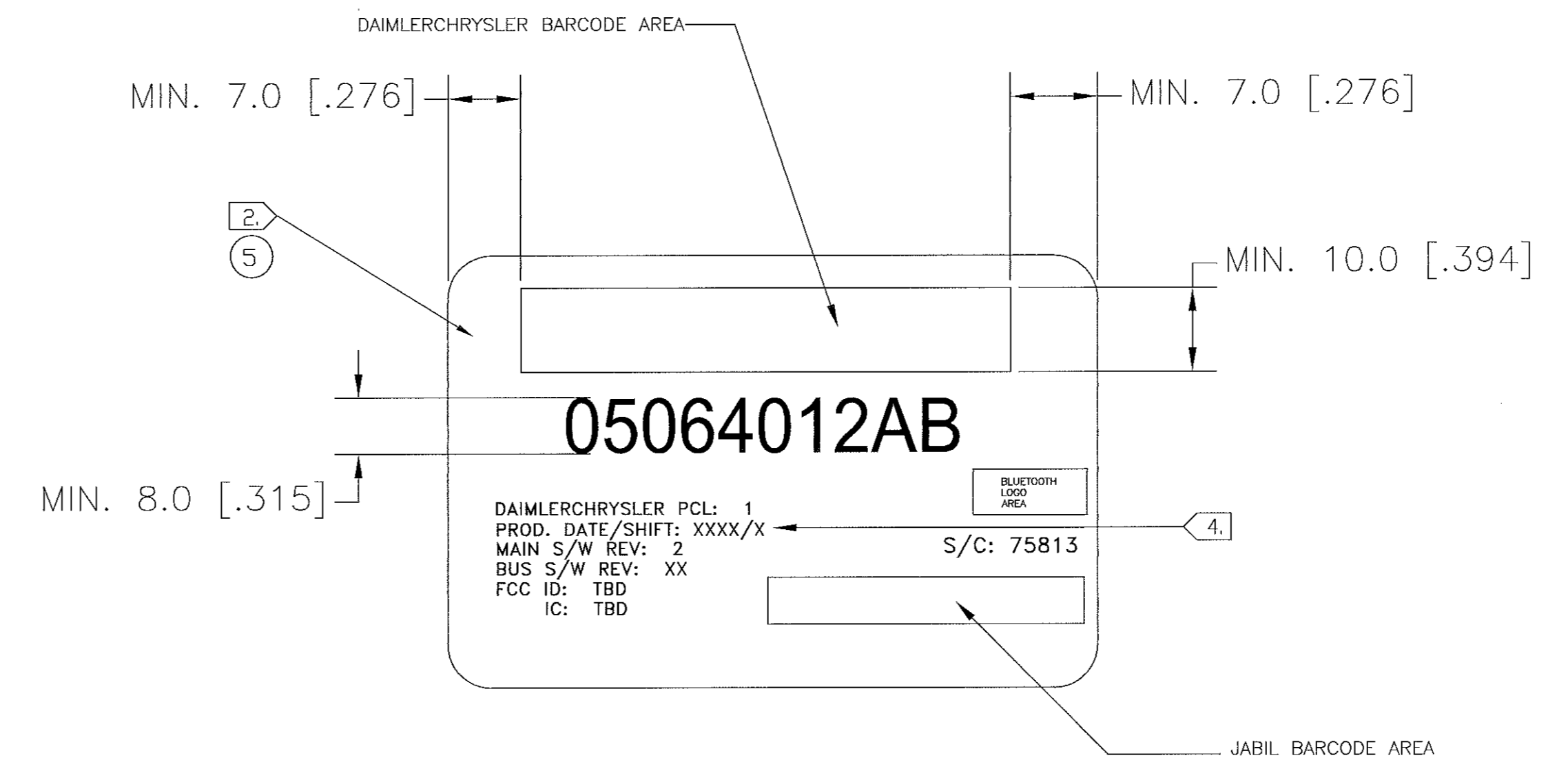

JOHNSON CONTROLS
AUTOMOTIVE SYSTEMS GROUP INTERIORS

NAME ELECTRONIC ASSEMBLY

ELECTRONICS STD. UNLESS OTHERWISE SPECIFIED		PROJECT	DRWN. BY	DATE
THIRD ANGLE PROJECTION		03.5 CS ICELAND HFM	BRET SUNNERVERILLE	21MAR02
DO NOT SCALE		CUSTOMER	CHKD. BY	DATE
X.XX DECIMAL ± 1.0 [± .040] X.XX DECIMAL ± .50 [± .020] X.XXX DECIMAL ± .15 [± .006]		DAIMLER CHRYSLER	AARON DENBOW	21MAR02
ANGULAR ± 2° 0' DRAFT ANGLES NOTED		SCALE	ENGR. APPR	DATE
DIMENSIONS ARE IN MILLIMETERS WITH EQUIVALENT INCHES SHOWN IN BRACKETS.		NONE	PRABIN PRADHAN	21MAR02
SIZE	TOOL NO. REF.	DWG. NO.	SHEET 1 OF 1	
D	DATA FORMAT	VM9962	REV.	
	ACAD		A	

8 7 6 5 4 3 2 1