

REPORT NUMBER 1775

November 2002

RADIO PERFORMANCE MEASUREMENTS

On the TOP-I2410-T0 Transceiver

FCC ID: CASTEL0062

SN: 14155062

In accordance with

FCC 47 CFR Parts 22 and 90

PREPARED BY:

Mike James

Test Technician

CHECKED & APPROVED BY:

SA Crompton

Laboratory Manager

TELTEST Laboratories

Tait Electronics Limited

PO Box 1645

558 Wairakei Road

Christchurch

New Zealand

Phone : (64) (3) 3583399

Fax: (64) (3) 3580432

TABLE OF CONTENTS

TEST	PAGE
TRANSMITTER OUTPUT POWER (CONDUCTED)	3
TRANSMITTER AUDIO FREQUENCY RESPONSE	4
MODULATION LIMITING	6
MODULATION LIMITING (STEADY STATE)	9
MODULATION LIMITING (INSTANTANEOUS)	11
OCCUPIED BANDWIDTH	13
SPURIOUS EMISSIONS (CONDUCTED)	18
TRANSMITTER FREQUENCY STABILITY (TEMPERATURE)	23
TRANSMITTER FREQUENCY STABILITY (VOLTAGE)	25
TRANSIENT FREQUENCY BEHAVIOR	26
LIST OF TEST EQUIPMENT	35

NAME OF TEST: TRANSMITTER OUTPUT POWER (CONDUCTED)

TEST CONDITIONS: Ambient Temperature 24 °C
 Relative Humidity 43 %
 Standard Voltage 7.5V DC

SPECIFICATION: FCC 47 CFR 2.1046

GUIDE: TIA/EIA-603 2.2.1

MEASUREMENT PROCEDURE:

1. The Equipment Under Test (EUT) was set up as shown on the following diagram.
2. The coaxial attenuator has an impedance of 50 Ohms.
3. The unmodulated output power was measured with an RF Power sensor connected to the Modulation analyser.
4. The actual power was calculated using the known path loss of the system.

MEASUREMENT RESULTS:

Manufacturer's Rated Output Power: Switchable: 1 W and 4 W

480.1 MHz	1 W nominal	4 W nominal
POWER (W)	0.9	3.4
Variation from Nominal (%)	-10%	-15%
Measurement Uncertainty (dB)	+0.63 -0.68	

LIMIT CLAUSE: FCC 47 CFR 90.205

- (o) The output power shall not exceed by more than 20% the manufacturer's rated output power for the particular transmitter.

TEST SETUP: See page 35 for Test Equipment information.

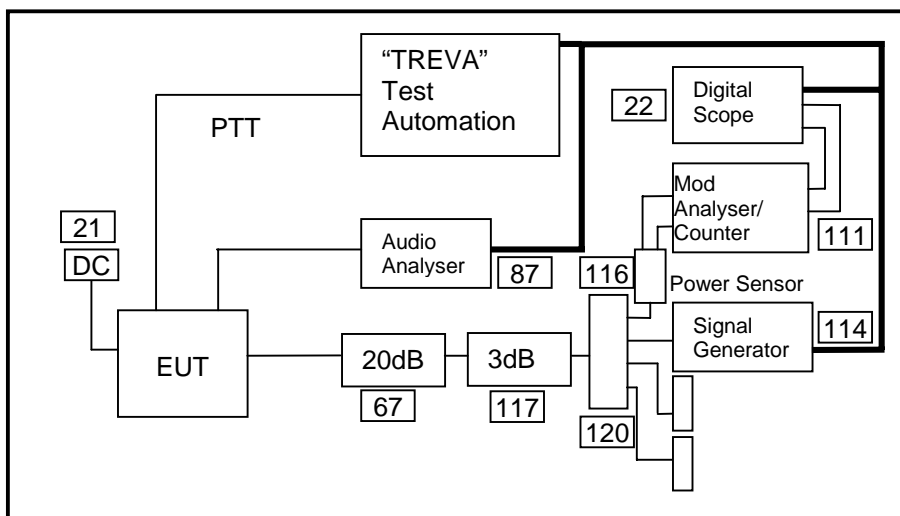

NAME OF TEST: TRANSMITTER AUDIO FREQUENCY RESPONSE
PRE-EMPHASIS

TEST CONDITIONS: Ambient Temperature 24 °C
Relative Humidity 43 %
Standard Voltage 7.5V DC

SPECIFICATION: FCC 47 CFR 2.1047 (a)

GUIDE: TIA/EIA-603 2.2.6

MEASUREMENT PROCEDURE:

1. The Equipment Under Test (EUT) was set up as shown on the following diagram.
2. An audio input tone of 1000Hz was applied with the level set to obtain 20% of maximum deviation. This was used as the 0dB reference point.
3. The AF was varied while the audio level was held constant.
4. The response in dB relative to 1000Hz was measured.

MEASUREMENT RESULTS: See the plots on the following page.

LIMIT CLAUSE: TIA/EIA-603 2.2.6

TEST SETUP: See page 35 for Test Equipment information.

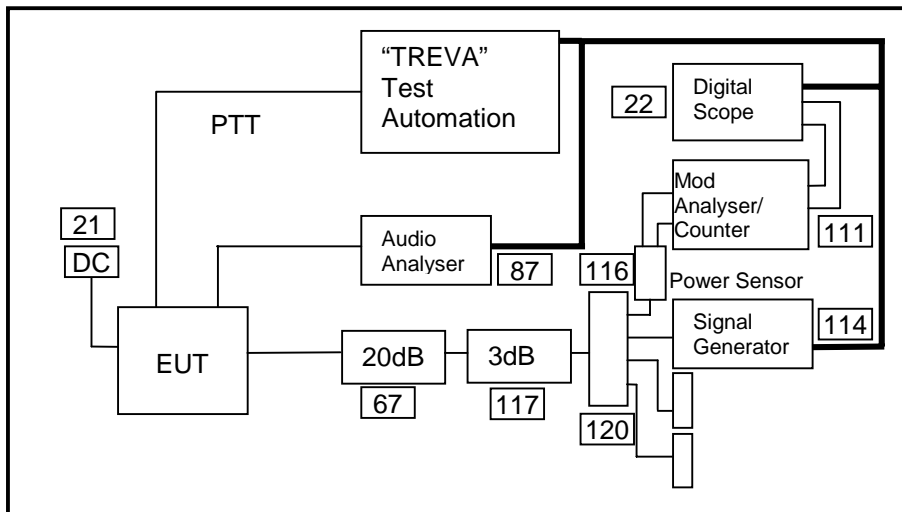

NAME OF TEST: TRANSMITTER AUDIO FREQUENCY RESPONSE
PRE-EMPHASIS

SPECIFICATION: FCC CFR 2.1047 (a)

TX FREQUENCY: 480.1 MHz

12.5kHz Channel Spacing

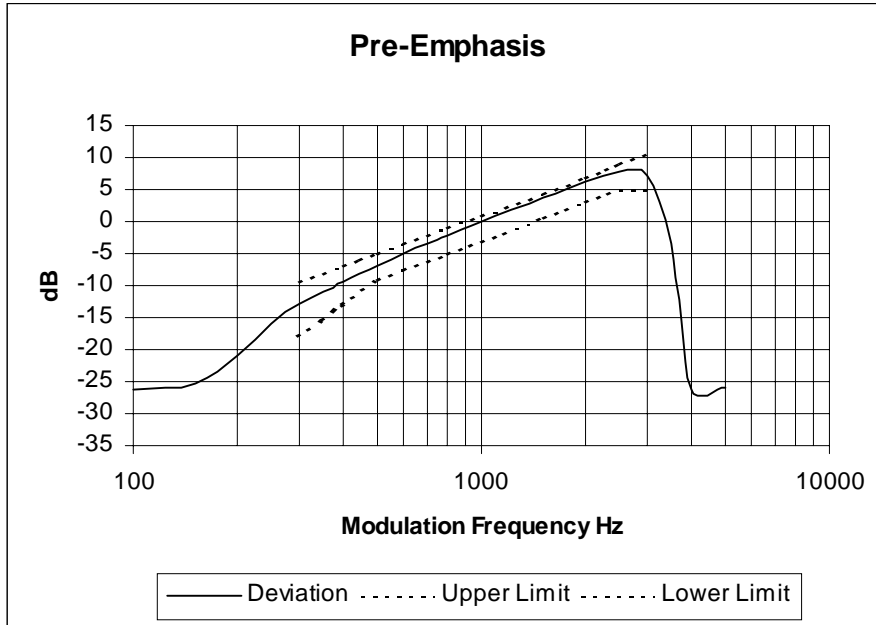

25kHz Channel Spacing

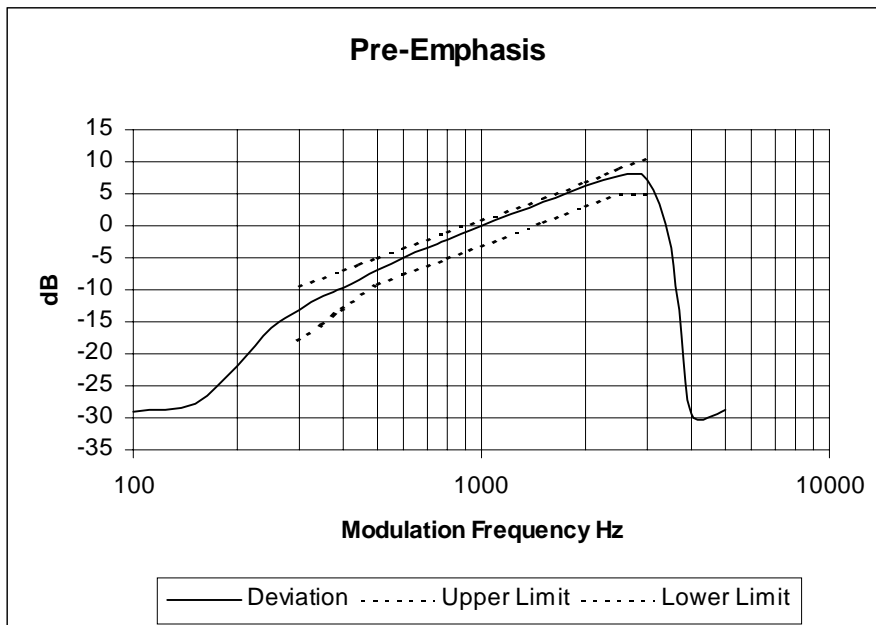

NAME OF TEST: TRANSMITTER MODULATION LIMITING

TEST CONDITIONS: Ambient Temperature 24 °C
 Relative Humidity 43 %
 Standard Voltage 7.5V DC

SPECIFICATION: FCC 47 CFR 2.1047 (b)

GUIDE: TIA/EIA-603 2.2.3

MEASUREMENT PROCEDURE:

1. The EUT was set up as shown on the following diagram.
2. The modulation response was measured at three audio frequencies while varying the input level.
3. Measurements were made for both Positive and Negative Deviation.

MEASUREMENT RESULTS:

See the plot on the following pages for 12.5 kHz & 25.0 kHz channel spacing..

LIMIT CLAUSE: FCC 47 CFR 90.211 (a)

TEST SETUP: See page 35 for Test Equipment information.

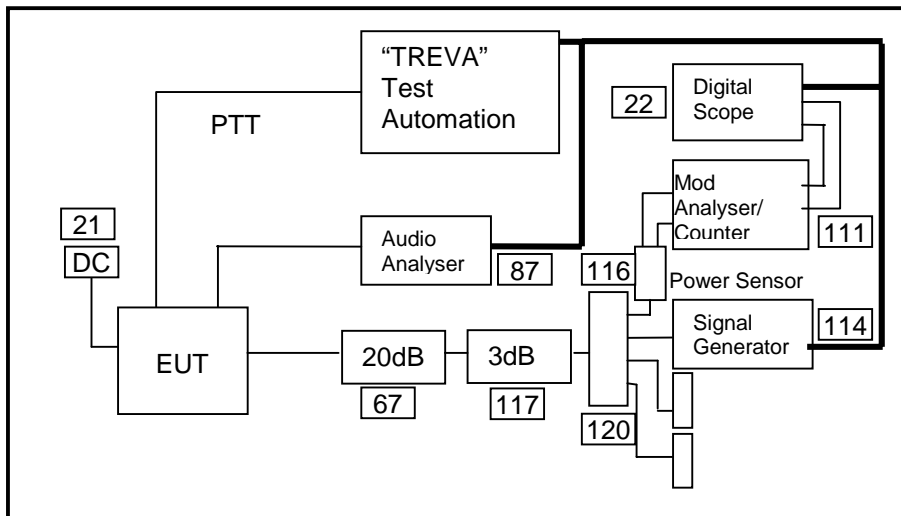

NAME OF TEST: TRANSMITTER MODULATION LIMITING

SPECIFICATION: FCC CFR 2.1047 (b)

TX FREQUENCY: 480.1 MHz

12.5 kHz Channel Spacing

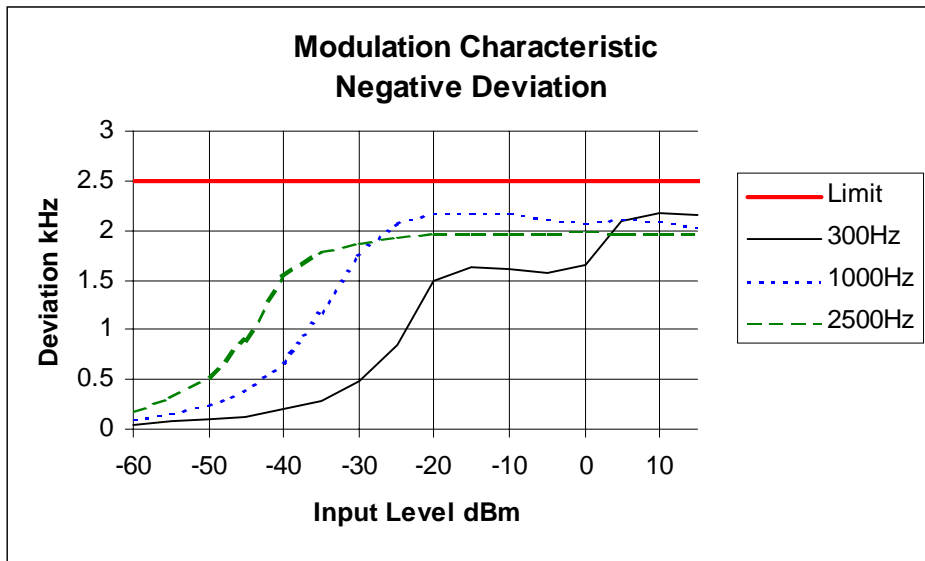
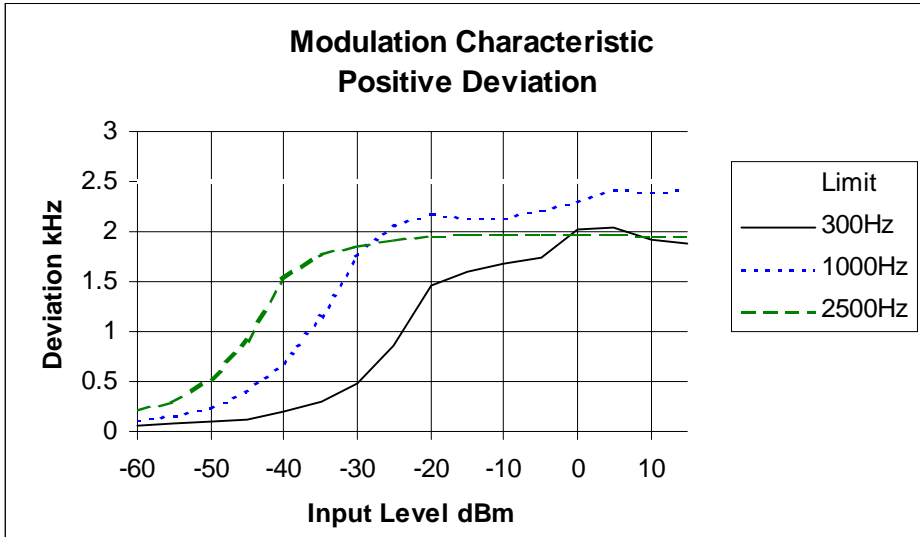

NAME OF TEST: TRANSMITTER MODULATION LIMITING

SPECIFICATION: FCC CFR 2.1047 (b)

TX FREQUENCY: 480.1 MHz

25 kHz Channel Spacing

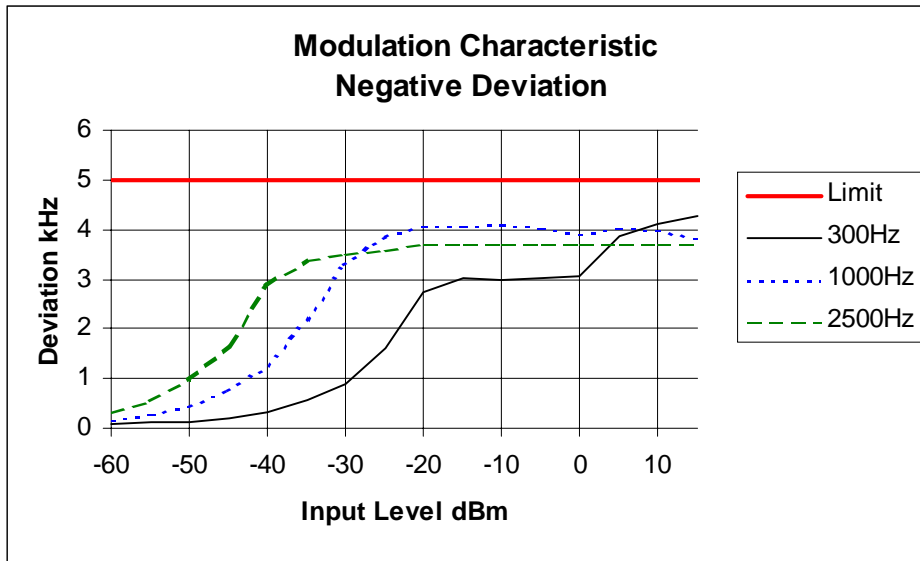
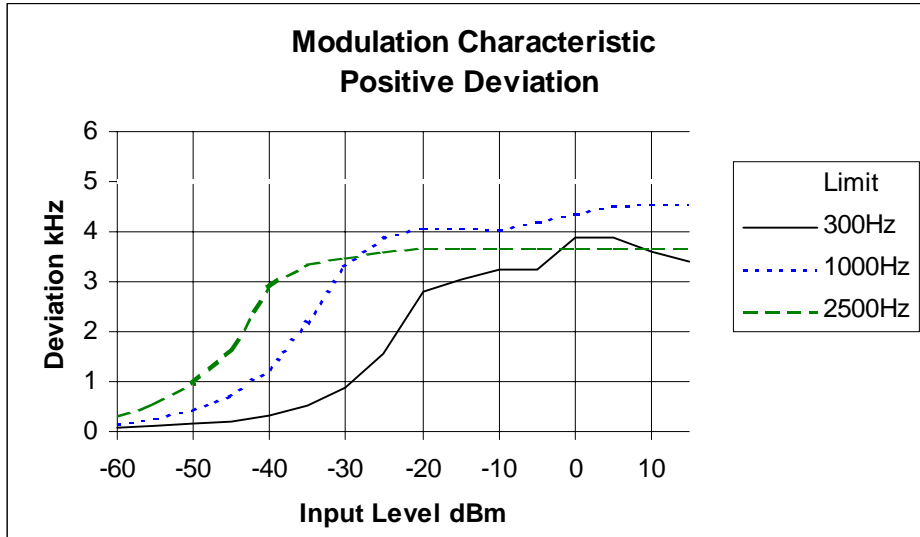

NAME OF TEST: TRANSMITTER MODULATION LIMITING
STEADY STATE

TEST CONDITIONS: Ambient Temperature 24 °C
Relative Humidity 43 %
Standard Voltage 7.5V DC

SPECIFICATION: FCC 47 CFR 2.1047 (b)

GUIDE: TIA/EIA-603 2.2.3

MEASUREMENT PROCEDURE:

1. The Equipment Under Test was set up as shown in the following diagram.
2. The modulation response was measured with a level stepped 20 dB above the level required to obtain 60% deviation at 1000Hz AF.
3. Measurements were made for both Positive and Negative deviation.

MEASUREMENT RESULTS:

See the plot on the following pages for 12.5 kHz & 25.0 kHz channel spacing.

LIMIT CLAUSE: FCC 47 CFR 90.211 (a) 2.1047 (b)

TEST SETUP: See page 35 for Test Equipment information.

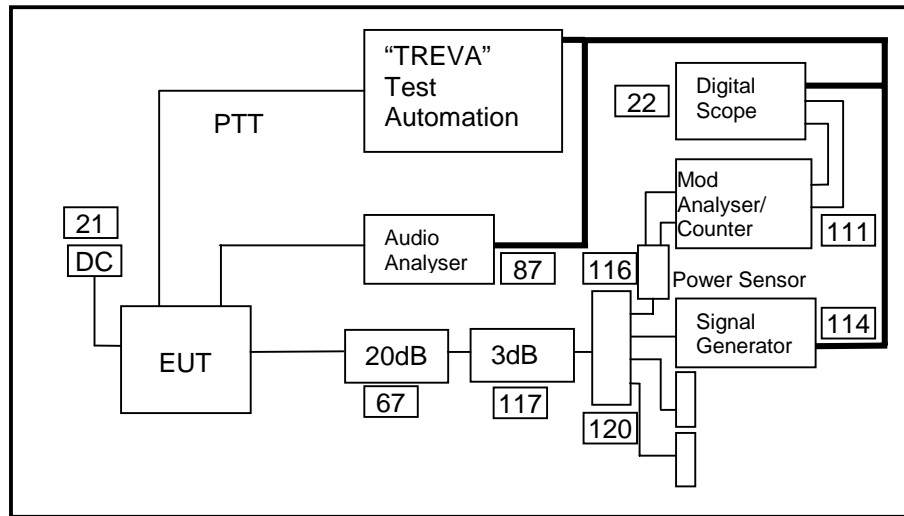

NAME OF TEST: TRANSMITTER MODULATION LIMITING
STEADY STATE

SPECIFICATION: FCC CFR 2.1047 (b)

TX FREQUENCY: 480.1 MHz

12.5 kHz Channel Spacing

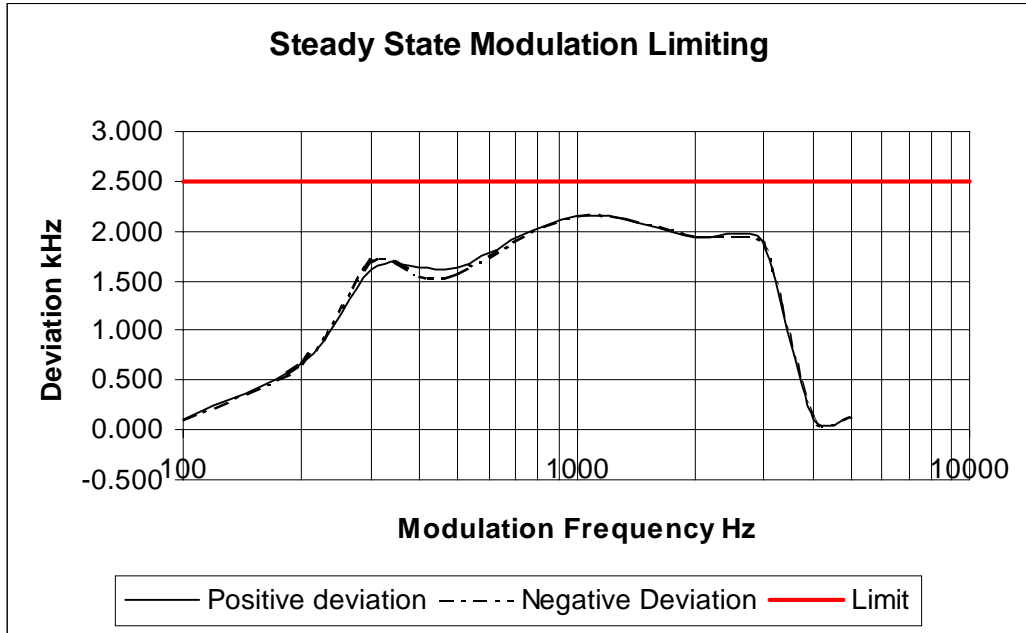

25 kHz Channel Spacing

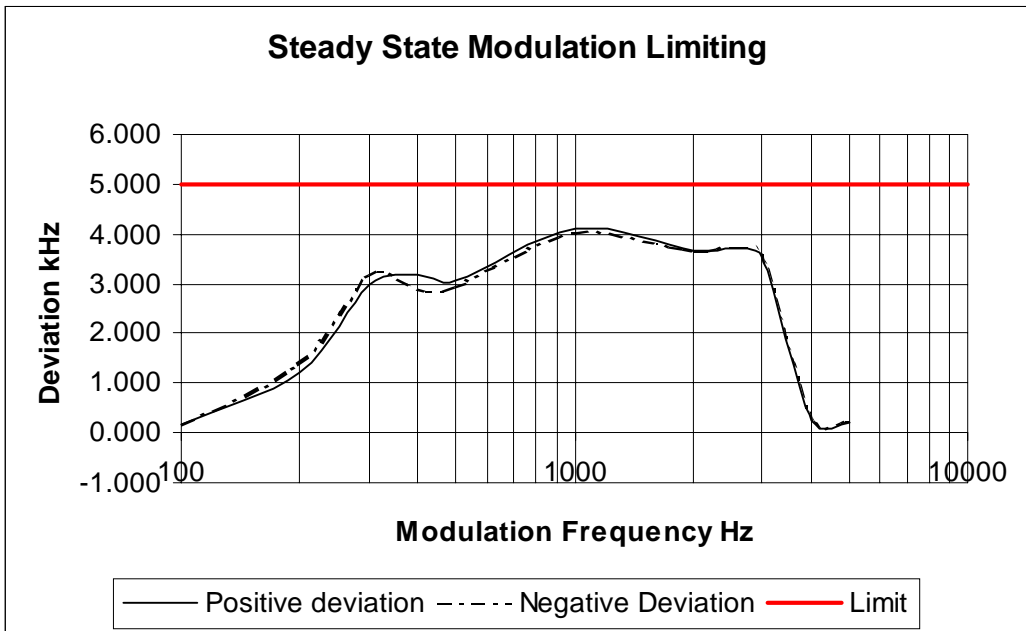

NAME OF TEST: TRANSMITTER MODULATION LIMITING INSTANTANEOUS

TEST CONDITIONS: Ambient Temperature 24°C
 Relative Humidity 43 %
 Standard Voltage 7.5V DC

SPECIFICATION: FCC 47 CFR 2.1047 (b)

GUIDE: TIA/EIA-603 2.2.3

MEASUREMENT PROCEDURE:

1. The Equipment Under Test was set up as shown in the following diagram.
2. The instantaneous modulation response was measured with as the level was stepped 20 dB above the level required to obtain 60% deviation at 1000Hz AF.
3. Measurements were made for both Positive and Negative deviation.

MEASUREMENT RESULTS:

See the plot on the following pages for 12.5 kHz & 25.0 kHz channel spacing.

LIMIT CLAUSE: FCC 47 CFR 90.211 (a) 2.1047 (b)

TEST SETUP: See page 35 for Test Equipment information.

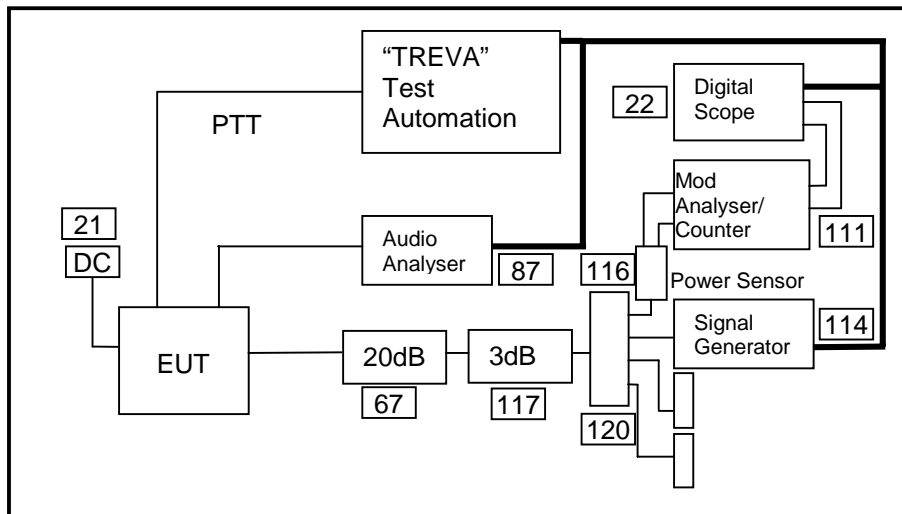

NAME OF TEST: TRANSMITTER MODULATION LIMITING INSTANTANEOUS

SPECIFICATION: FCC CFR 2.1047 (b)

TX FREQUENCY: 480.1 MHz

12.5 kHz Channel Spacing

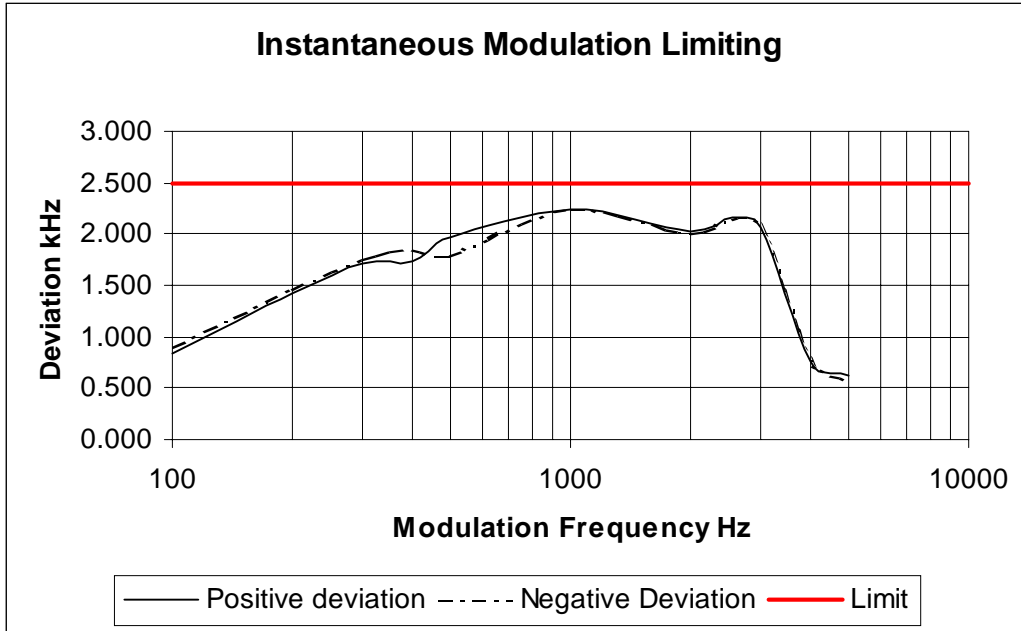

25 kHz Channel Spacing

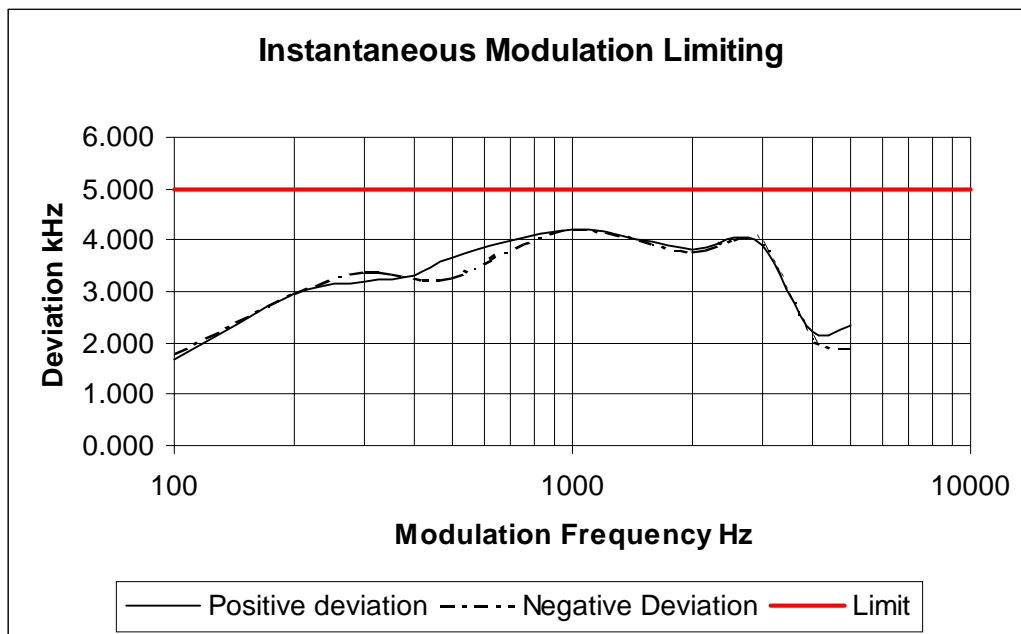

NAME OF TEST: OCCUPIED BANDWIDTH

TEST CONDITIONS: Ambient Temperature 24°C
 Relative Humidity 43 %
 Standard Voltage 7.5V DC

SPECIFICATION: FCC 47 CFR 2.1049 (c)

GUIDE: TIA/EIA-603 2.2.11

MEASUREMENT PROCEDURE:

1. The Equipment Under Test was set up as shown in the following diagram.
2. The EUT was modulated by a 2500Hz tone at an input level 16dB above a level that produced 50% deviation. The input level was established at the frequency of maximum response of the audio modulating circuit.
3. The Occupied Bandwidth was measured on the Spectrum Analyser with the controls set as shown on the following plots.

MEASUREMENT RESULTS:

See the plots on the following pages for 12.5 kHz & 25.0 kHz channel spacing.

LIMIT CLAUSE: FCC 47 CFR 90.210

TEST SETUP: See page 35 for Test Equipment information.

Emission Mask D 12.5 kHz Channel Spacing

Emission Mask B 25 kHz Channel Spacing

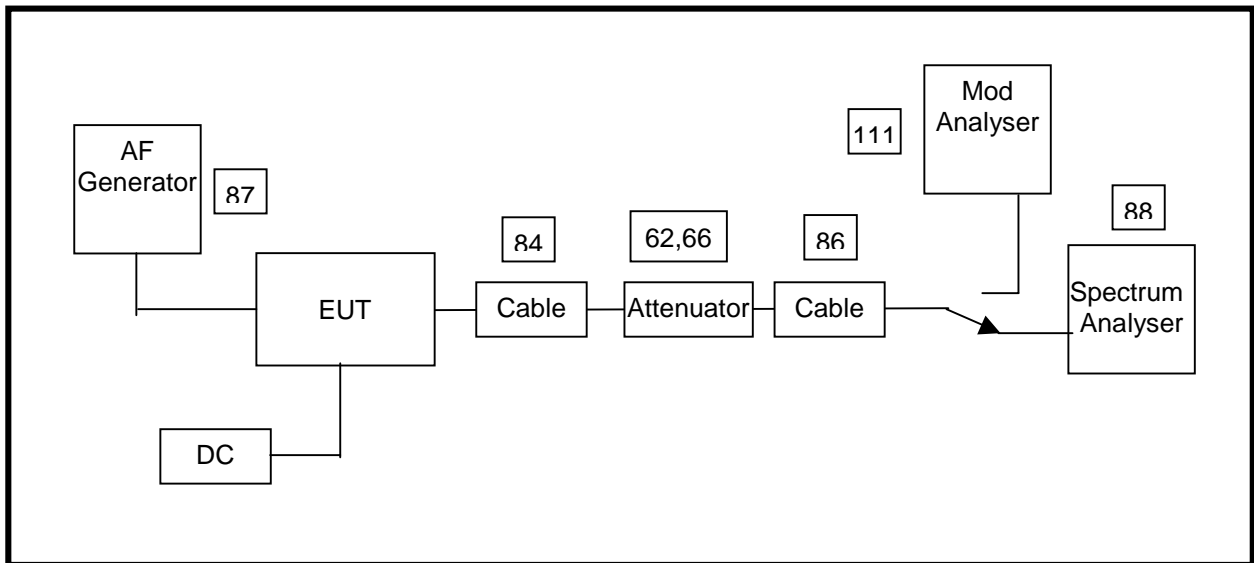

NAME OF TEST: OCCUPIED BANDWIDTH
SPECIFICATION: FCC CFR 2.1049 (c)
TX FREQUENCY: 480.1 MHz

12.5kHz Channel Spacing 1Watt Transmitter Power

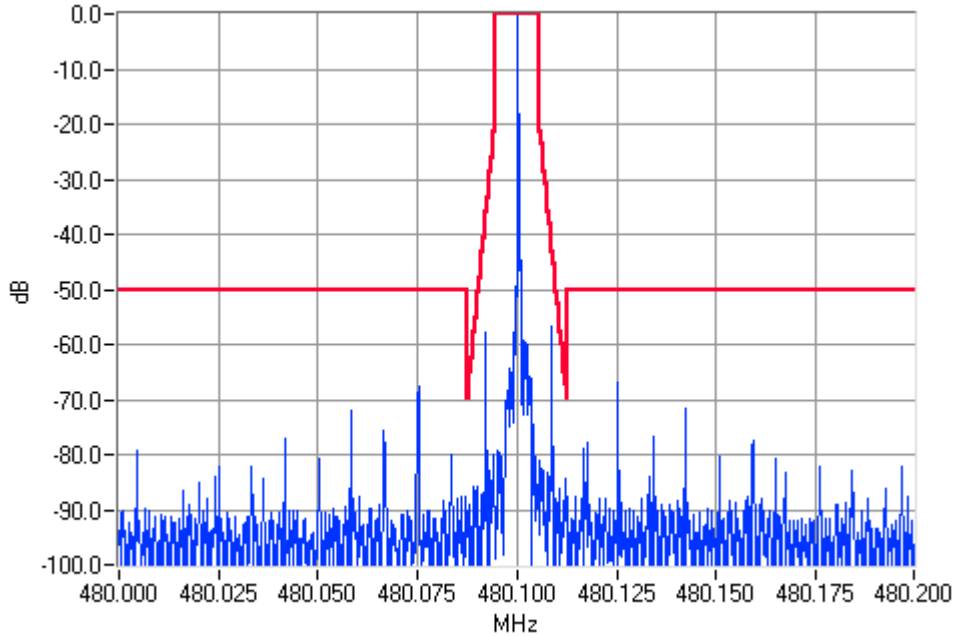

Unmodulated 480.1000MHz Mask D 1W Pass

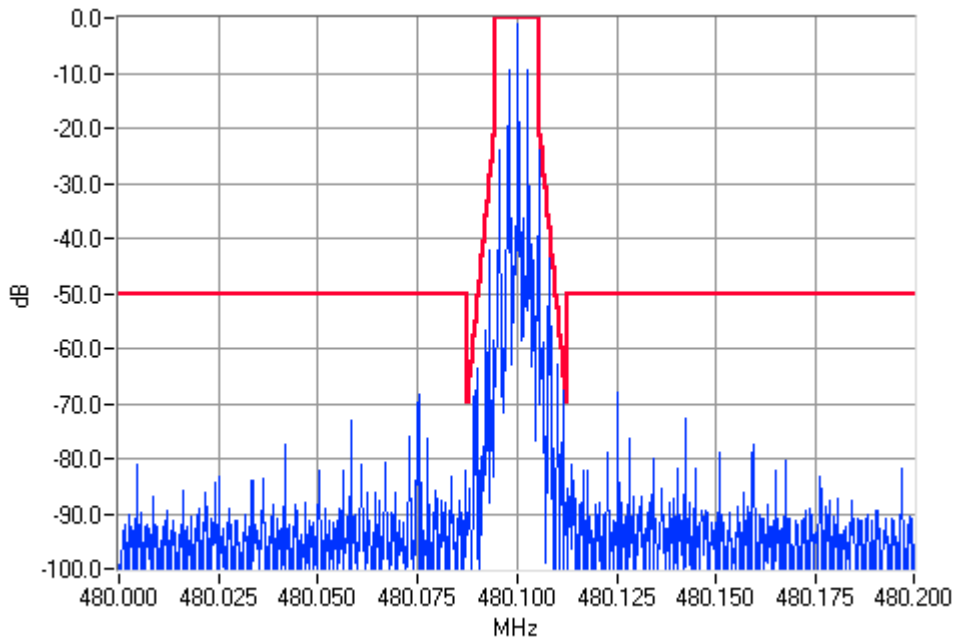

Analogue Modulation 480.1000MHz Mask D 1W Pass

NAME OF TEST: OCCUPIED BANDWIDTH
SPECIFICATION: FCC CFR 2.1049 (c)
TX FREQUENCY: 480.1 MHz

12.5kHz Channel Spacing 4Watts Transmitter Power

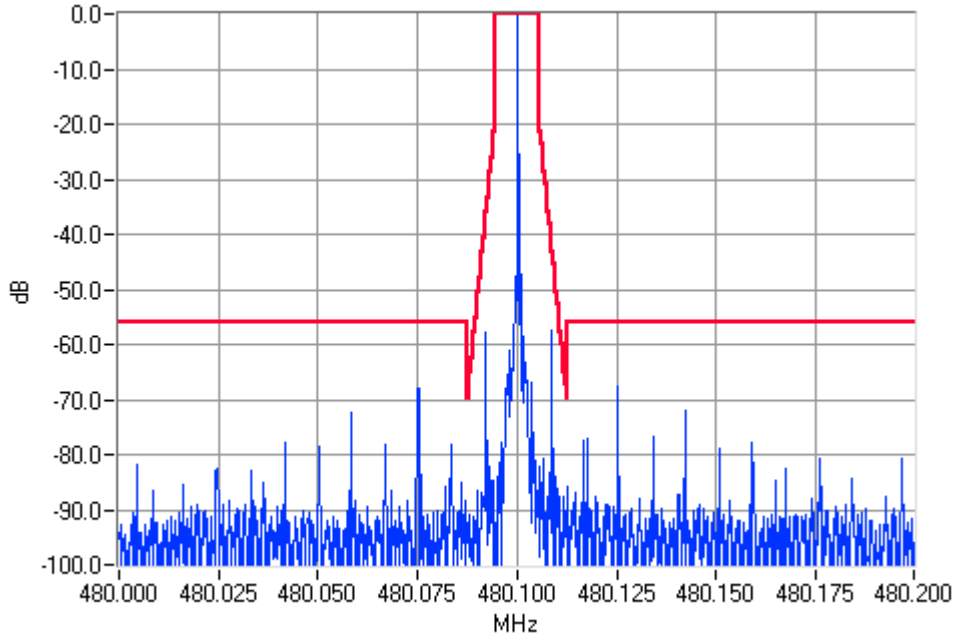

Unmodulated 480.1000MHz Mask D 4W Pass

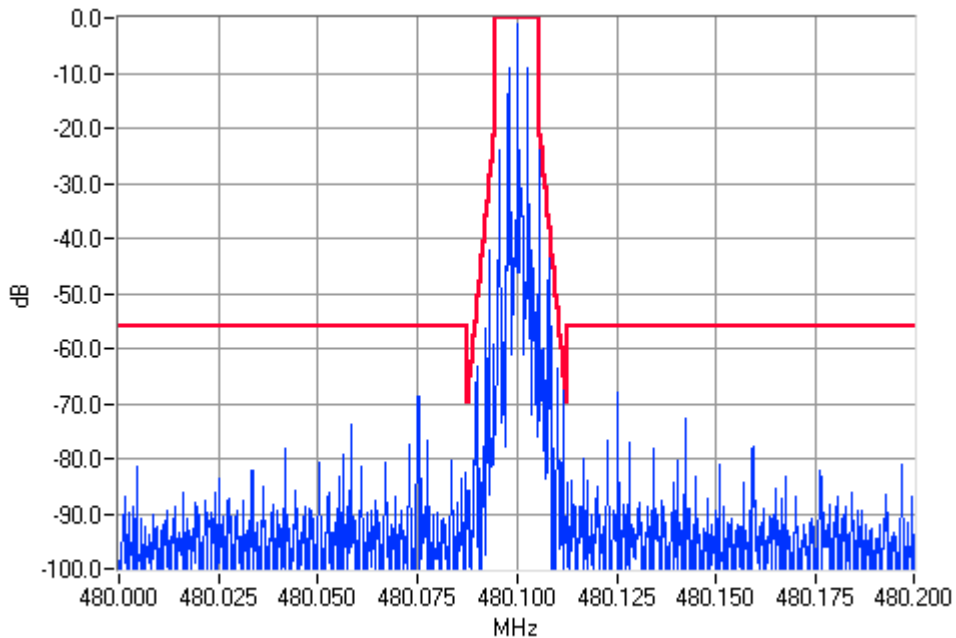

Analogue Modulation 480.1000MHz Mask D 4W Pass

NAME OF TEST: OCCUPIED BANDWIDTH
SPECIFICATION: FCC CFR 2.1049 (c)
TX FREQUENCY: 480.1 MHz

25kHz Channel Spacing 1Watt Transmitter Power

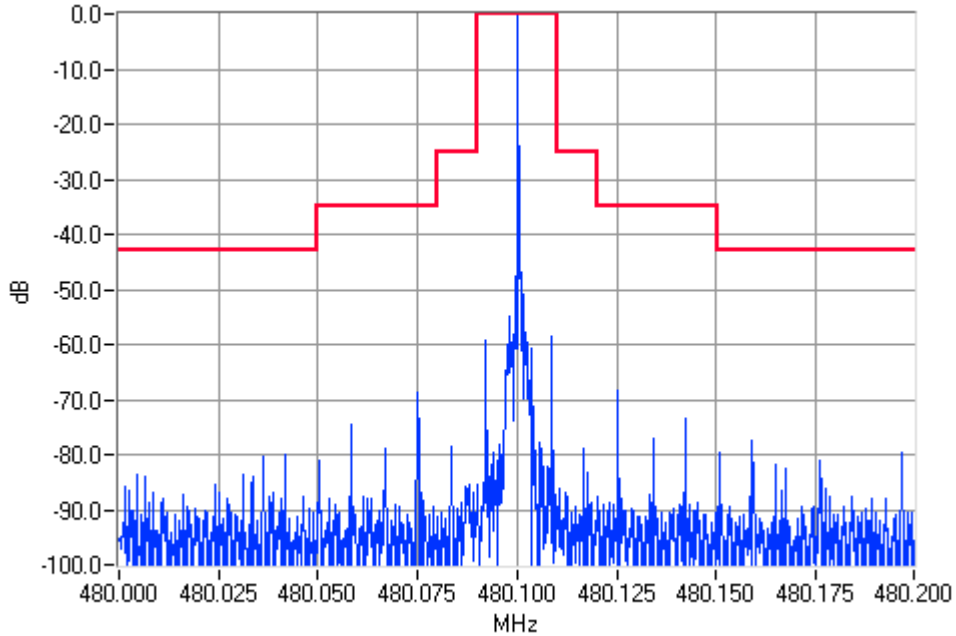

Unmodulated 480.1000MHz Mask B 1W Pass

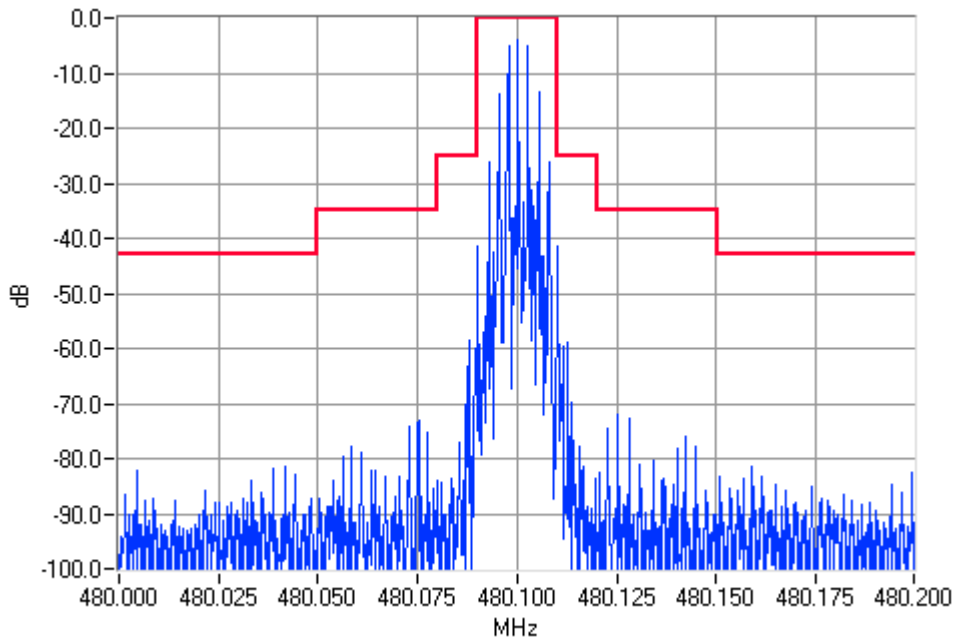

Analogue Modulation 480.1000MHz Mask B 1W Pass

NAME OF TEST: OCCUPIED BANDWIDTH
SPECIFICATION: FCC CFR 2.1049 (c)
TX FREQUENCY: 480.1 MHz

25kHz Channel Spacing 4Watts Transmitter Power

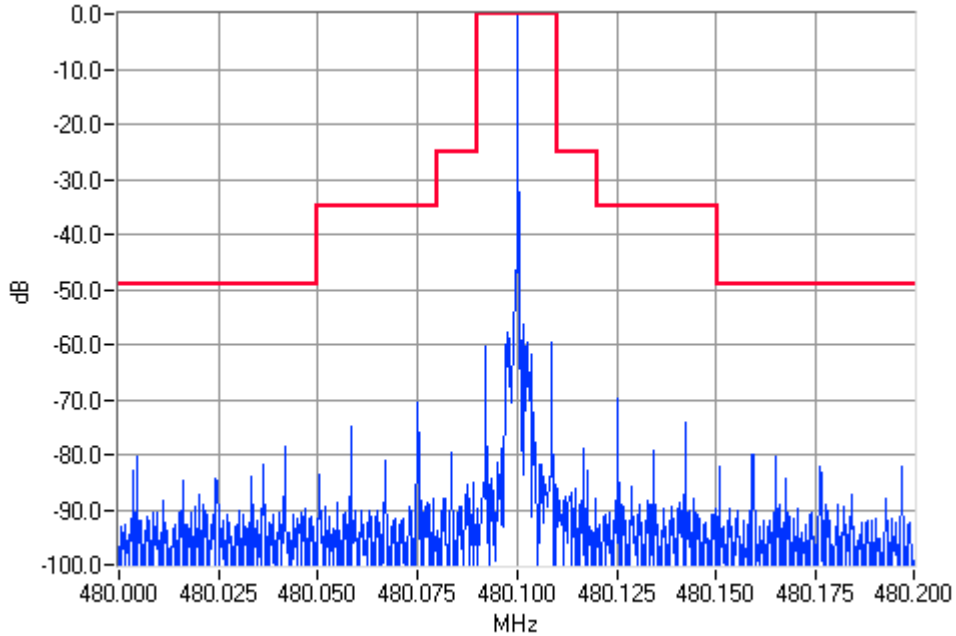

Unmodulated 480.1000MHz Mask B 4W Pass

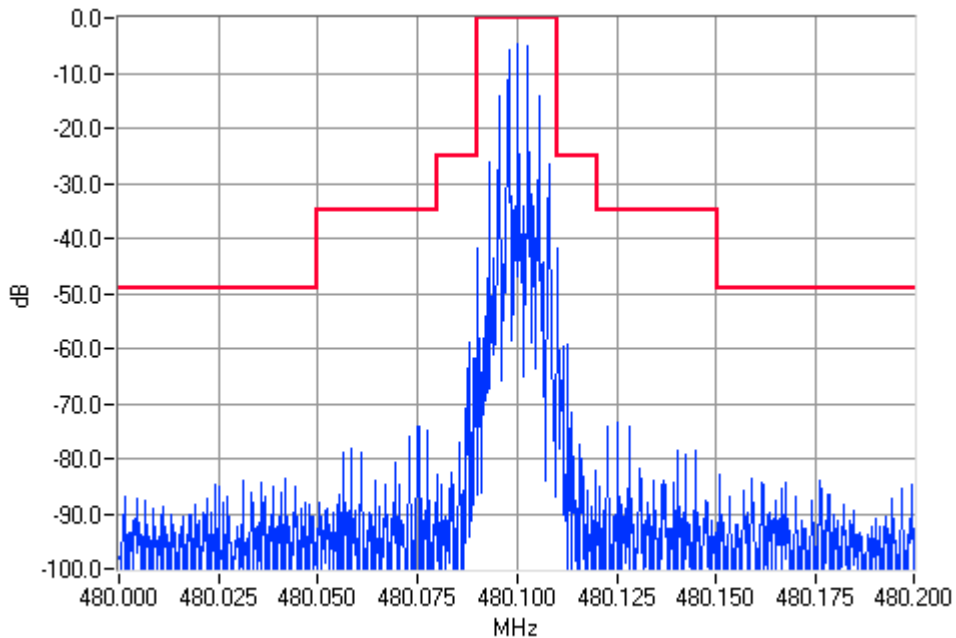

Analogue Modulation 480.1000MHz Mask B 4W Pass

NAME OF TEST: SPURIOUS EMISSIONS (CONDUCTED)

TEST CONDITIONS: Ambient Temperature 24°C
 Relative Humidity 43 %
 Standard Voltage 7.5V DC

SPECIFICATION: FCC 47 CFR 2.1051

GUIDE: TIA/EIA-603 2.2.13

MEASUREMENT PROCEDURE:

1. The Equipment Under Test was set up as shown in the following diagram.
2. The frequency range examined was from the lowest frequency generated within the EUT, to a frequency higher than the 10th Harmonic: 100kHz to Fc-BW
 Fc+BW to 4.801 GHz
3. Spurious emissions that were attenuated more than 20dB below the limit were not recorded.

MEASUREMENT RESULTS:

See the tables on the following pages for 12.5 kHz & 25.0 kHz channel spacing.

LIMIT CLAUSE: FCC 47 CFR 90.210

TEST SETUP: See page 35 for Test Equipment information.

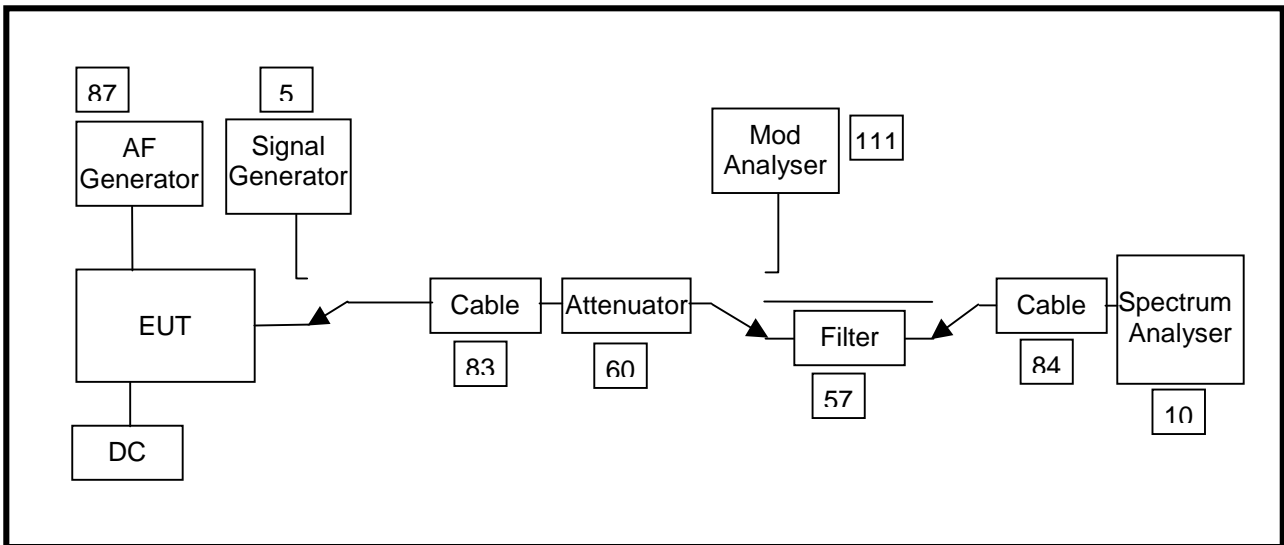

NAME OF TEST: SPURIOUS EMISSIONS (CONDUCTED)

SPECIFICATION: FCC CFR 2.1051

TX FREQUENCY: 480.1 MHz

12.5 kHz Channel Spacing	480.1 MHz @ 1 W	Emission Mask D
Emission Frequency (MHz)	Level (dBm)	Level (dBc)
~	~	~
No emissions were detected at a level greater than 20 dB below the limit.		

LIMITS:

Carrier Output Power Watts	Emission Mask D 12.5 kHz Channel Spacing $50 + 10 \text{ Log}_{10} (P_{\text{Watts}})$	
1 W	-20 dBm	-50 dBc
4 W	-20dBm	-56 dBc

NAME OF TEST: SPURIOUS EMISSIONS (CONDUCTED)

SPECIFICATION: FCC CFR 2.1051

TX FREQUENCY: 480.1 MHz

12.5 kHz Channel Spacing		480.1 MHz @ 4 W		Emission Mask D	
Emission Frequency (MHz)		Level (dBm)		Level (dBc)	
~		~		~	
No emissions were detected at a level greater than 20 dB below the limit.					

LIMITS:

Carrier Output Power Watts	Emission Mask D 12.5 kHz Channel Spacing $50 + 10 \log_{10}(P_{\text{Watts}})$	
	1 W	-20dBm
4 W	-20 dBm	-56 dBc

NAME OF TEST: SPURIOUS EMISSIONS (CONDUCTED)

SPECIFICATION: FCC CFR 2.1051

TX FREQUENCY: 480.1 MHz

25.0 kHz Channel Spacing		480.1 MHz @ 1 W		Emission Mask B	
Emission Frequency (MHz)		Level (dBm)		Level (dBc)	
~		~		~	
No emissions were detected at a level greater than 20 dB below the limit.					

LIMITS:

Carrier Output Power Watts	Emission Mask B 25 kHz Channel Spacing $43 + 10 \text{ Log}_{10}(P_{\text{Watts}})$	
	1 W	-13 dBm
4 W	-13 dBm	-49 dBc

NAME OF TEST: SPURIOUS EMISSIONS (CONDUCTED)

SPECIFICATION: FCC CFR 2.1051

TX FREQUENCY: 480.1 MHz

25.0 kHz Channel Spacing		480.1 MHz @ 4 W	Emission Mask B
Emission Frequency (MHz)	Level (dBm)	Level (dBc)	
~	~	~	
No emissions were detected at a level greater than 20 dB below the limit.			

LIMITS:

Carrier Output Power Watts	Emission Mask B 25 kHz Channel Spacing $43 + 10 \text{ Log}_{10} (P_{\text{Watts}})$	
1 W	-13dBm	-43 dBc
4 W	-13 dBm	-49 dBc

NAME OF TEST: TRANSMITTER FREQUENCY STABILITY (TEMPERATURE)

TEST CONDITIONS: Ambient Temperature 23°C
 Relative Humidity 42 %
 Standard Voltage 7.5V DC

SPECIFICATION: FCC 47 CFR 2.1055 (a) (1)

GUIDE: TIA/EIA-603 2.2.2

MEASUREMENT PROCEDURE:

1. The Equipment Under Test was set up as shown in the following diagram.
2. The EUT was tested for frequency error from -30°C to +50°C in 10°C increments
3. The frequency error was recorded in parts per million (ppm).

MEASUREMENT RESULTS: See the plot on the following page.

LIMIT CLAUSE: FCC 47 CFR 90.213

Frequency Range: 421 MHz to 512 MHz

Channel Spacing (kHz)	Frequency Error (ppm)
12.5	2.5
25.0	5.0

TEST SETUP: See page 35 for Test Equipment information.

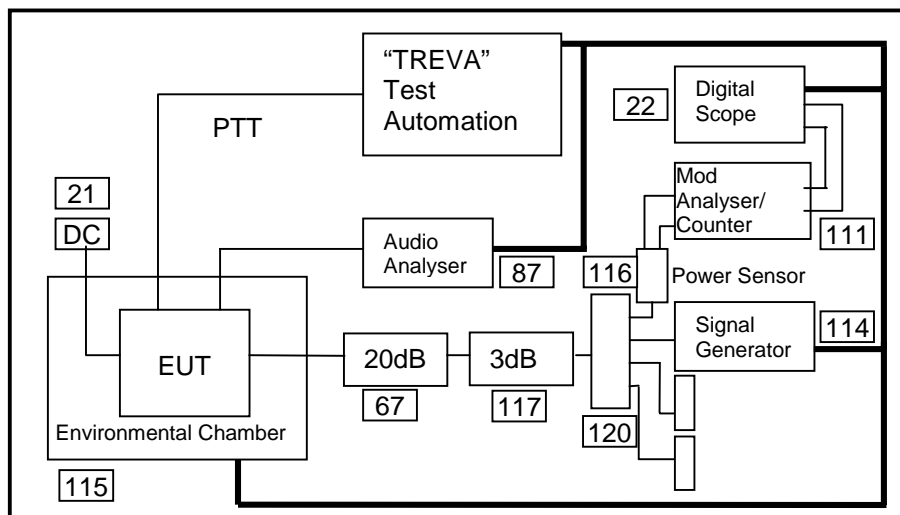

NAME OF TEST: TRANSMITTER FREQUENCY STABILITY (TEMPERATURE)

SPECIFICATION: FCC 47 CFR 2.1055 (a) (1)

TX FREQUENCY: 480.1 MHz

12.5kHz Channel Spacing

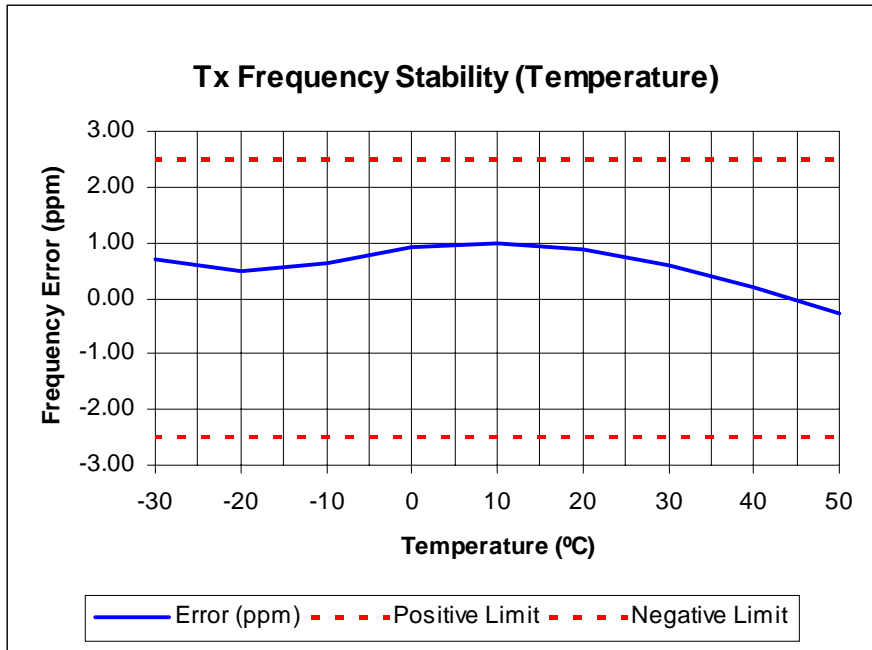

25kHz Channel Spacing

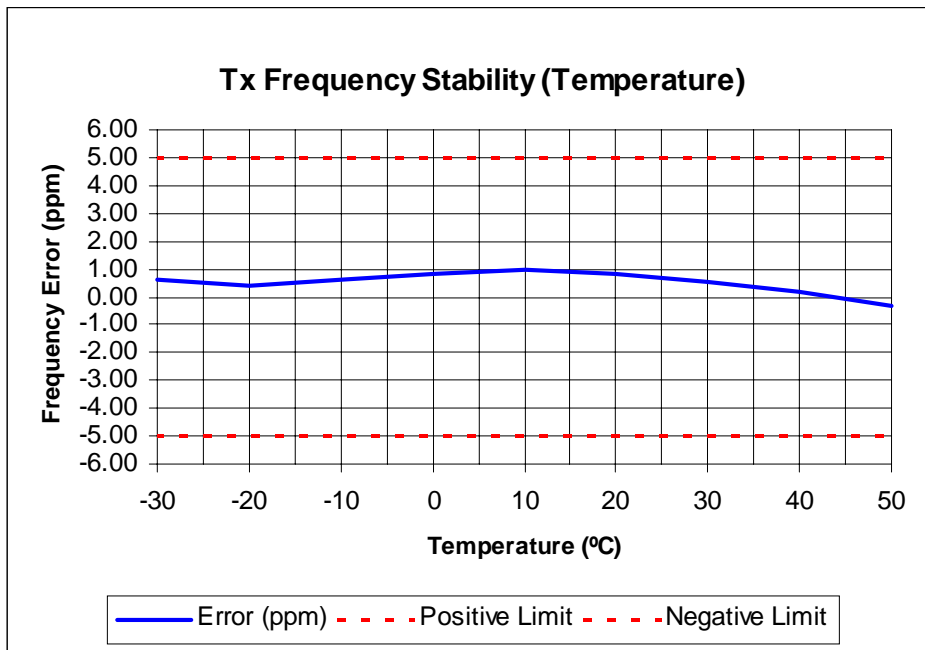

NAME OF TEST: TRANSMITTER FREQUENCY STABILITY (VOLTAGE)

TEST CONDITIONS: Ambient Temperature 21.5°C
 Relative Humidity 45 %
 Standard Voltage 7.5V DC

SPECIFICATION: FCC 47 CFR 2.1055 (d) (1)

GUIDE: TIA/EIA-603 2.2.2

MEASUREMENT PROCEDURE:

1. The Equipment Under Test was set up as shown in the following diagram.
2. The EUT was tested for frequency error with input voltages to the radio of the maximum and end-point battery voltages stated by the manufacturer.
3. The frequency error was recorded in parts per million (ppm).

TEST SETUP: See page 35 for Test Equipment information.

MEASUREMENT RESULTS:

Frequency Range: 421 MHz to 512 MHz

Channel Spacing (kHz)	FREQUENCY ERROR (ppm) @ 480.1 MHz		
	7.5 V DC	6.75 V DC	
12.5	0.54	0.53	~
25.0	0.60	0.58	~

LIMIT CLAUSE: FCC 47 CFR 90.213

Channel Spacing (kHz)	Frequency Error (ppm)
12.5	2.5
25.0	5.0

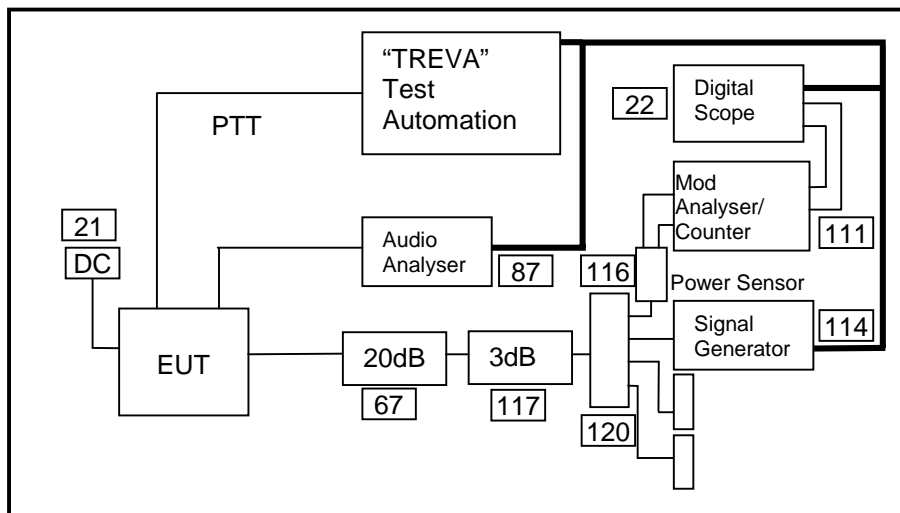

NAME OF TEST: TRANSIENT FREQUENCY BEHAVIOR

TEST CONDITIONS: Ambient Temperature 26°C
 Relative Humidity 40 %
 Standard Voltage 7.5V DC

SPECIFICATION: FCC 47 CFR 90.214

GUIDE: TIA/EIA-603 2.2.19

MEASUREMENT PROCEDURE:

1. The Equipment Under Test was set up as shown in the following diagram.
2. Measurements and plots were made following the TIA/EIA procedure.

MEASUREMENT RESULTS: See the tables and plots on the following pages

LIMIT CLAUSE: FCC 47 CFR 90.214

TEST SETUP: See page 35 for Test Equipment information.

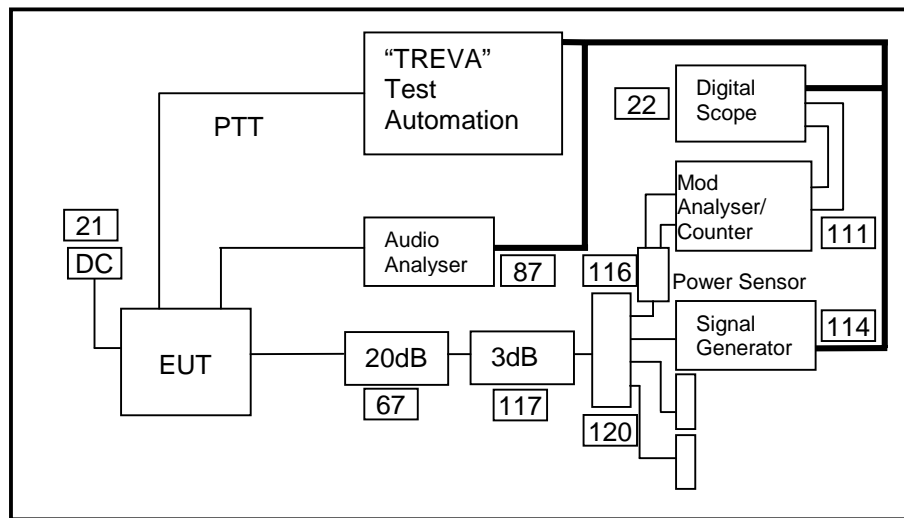

NAME OF TEST: TRANSIENT FREQUENCY BEHAVIOUR
 SPECIFICATION: FCC 47 CFR 90.214
 TX FREQUENCY: 480.1 MHz

12.5 kHz Channel Spacing

FREQUENCY	480.1 MHz @ 1 W TX	
TRANSIENT RESPONSE PERIOD	CARRIER PEAK VARIATION FROM NORMAL	
	Key ON (kHz)	Key OFF (kHz)
t ₁	2.1	N/A
t ₂	0.6	N/A
t ₃	N/A	-0.7
t ₂ → t ₃ ppm	1.2	
ERROR LIMIT (t ₂ → t ₃) ppm	2.5	

Confirm that during periods t ₁ and t ₃ the frequency difference does not exceed the value of one channel separation.	YES	NO
	✓	
Confirm that during the period t ₂ the frequency difference does not exceed half a channel separation.	YES	NO
	✓	
Confirm that during the period t ₂ to t ₃ the frequency difference does not exceed the frequency error limit.	YES	NO
	✓	

LIMIT:

TRANSIENT PERIODS	FREQUENCY RANGE 150MHz – 174 MHz	FREQUENCY RANGE 421MHz – 512 MHz
t ₁ (ms)	5 ms	10 ms
t ₂ (ms)	20 ms	25 ms
t ₃ (ms)	5 ms	10 ms

NAME OF TEST: TRANSIENT FREQUENCY BEHAVIOUR

SPECIFICATION: FCC 47 CFR 90.214

TX FREQUENCY: 480.1 MHz
12.5kHz Channel Spacing 1 W

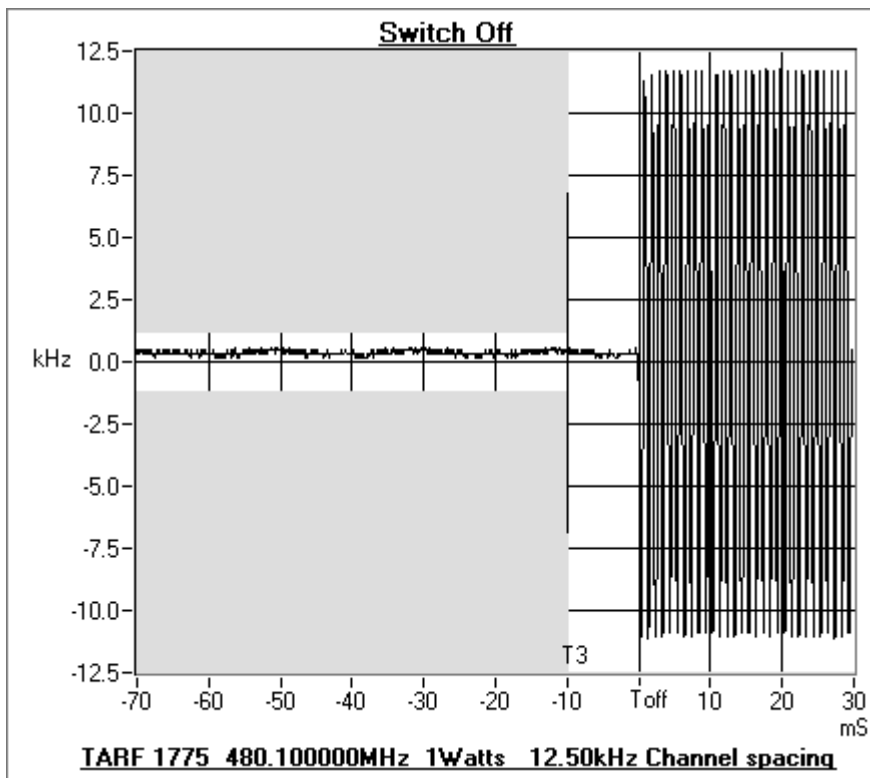
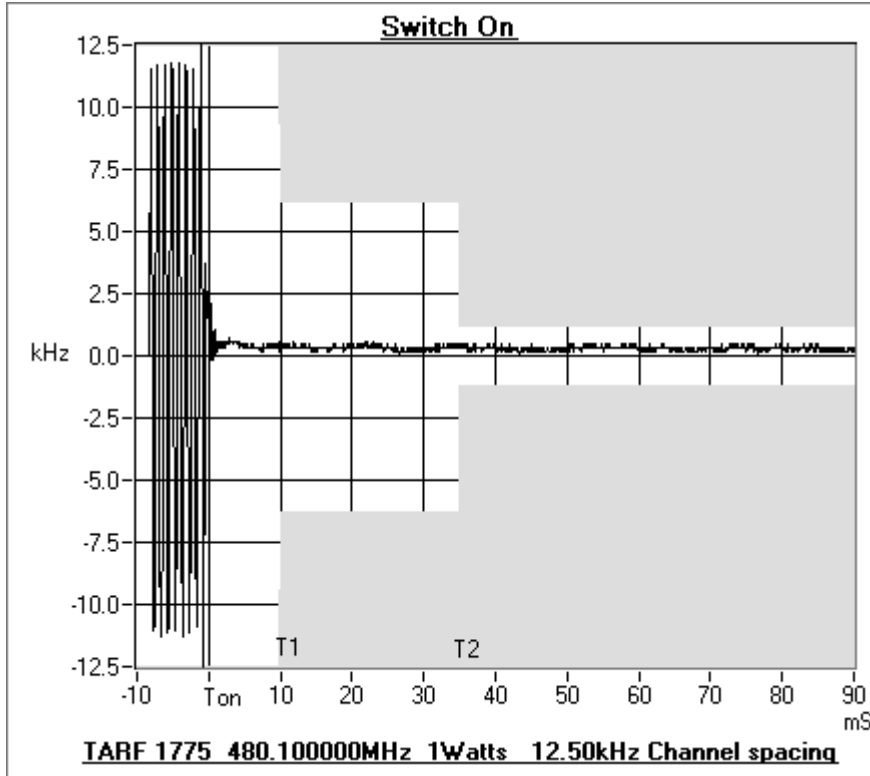

NAME OF TEST: TRANSIENT FREQUENCY BEHAVIOUR

SPECIFICATION: FCC 47 CFR 90.214

TX FREQUENCY: 480.1 MHz

12.5 kHz Channel Spacing

FREQUENCY	480.1 MHz @ 4 W TX	
TRANSIENT RESPONSE PERIOD	CARRIER PEAK VARIATION FROM NORMAL	
	Key ON (kHz)	Key OFF (kHz)
t ₁	1.5	N/A
t ₂	0.5	N/A
t ₃	N/A	1.0
t ₂ → t ₃ ppm	1.2	
ERROR LIMIT (t ₂ → t ₃) ppm	2.5	

Confirm that during periods t ₁ and t ₃ the frequency difference does not exceed the value of one channel separation.	YES	NO
	✓	
Confirm that during the period t ₂ the frequency difference does not exceed half a channel separation.	YES	NO
	✓	
Confirm that during the period t ₂ to t ₃ the frequency difference does not exceed the frequency error limit.	YES	NO
	✓	

LIMIT:

TRANSIENT PERIODS	FREQUENCY RANGE 150MHz – 174 MHz	FREQUENCY RANGE 421MHz – 512 MHz
t ₁ (ms)	5 ms	10 ms
t ₂ (ms)	20 ms	25 ms
t ₃ (ms)	5 ms	10 ms

NAME OF TEST: TRANSIENT FREQUENCY BEHAVIOUR

SPECIFICATION: FCC 47 CFR 90.214

TX FREQUENCY: 480.1 MHz
12.5kHz Channel Spacing 4 W

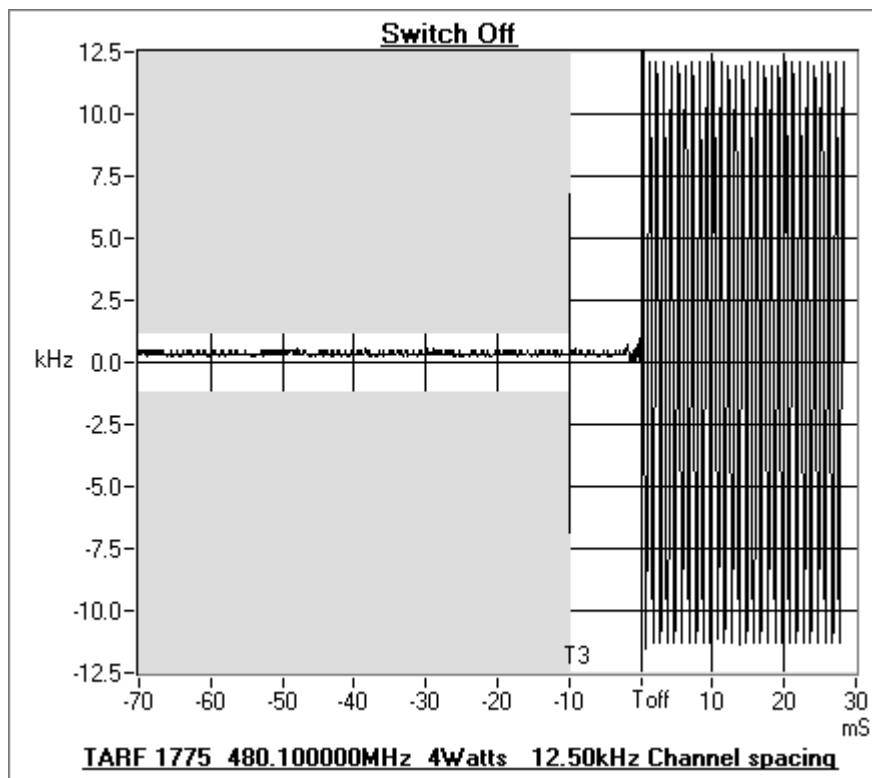
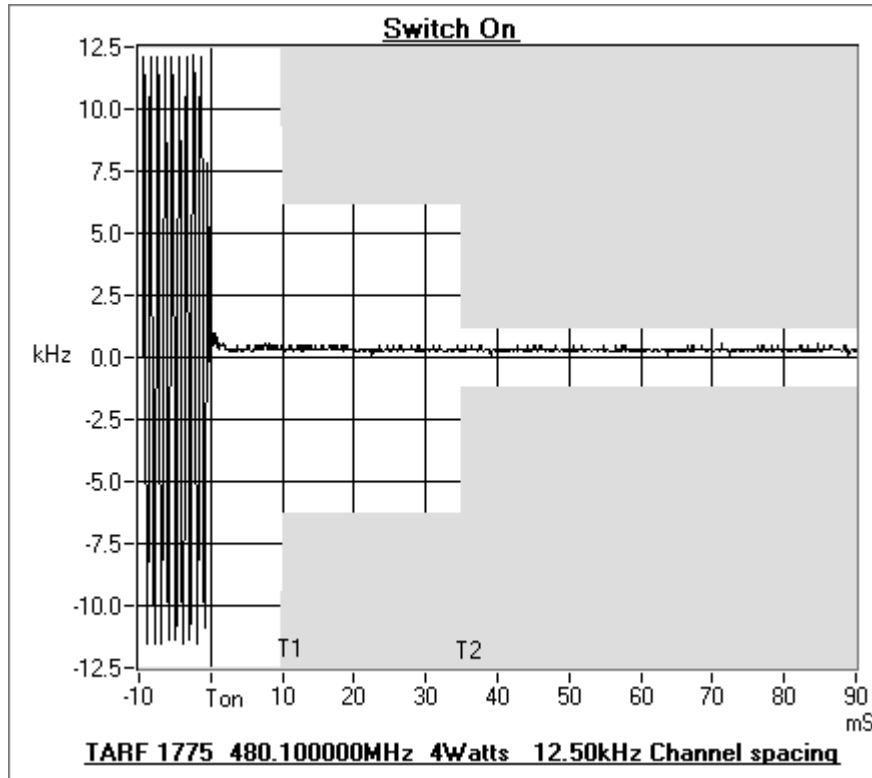

NAME OF TEST: TRANSIENT FREQUENCY BEHAVIOUR
 SPECIFICATION: FCC 47 CFR 90.214
 TX FREQUENCY: 480.1 MHz

25.0 kHz Channel Spacing

FREQUENCY	480.1 MHz @ 1 W TX	
TRANSIENT RESPONSE PERIOD	CARRIER PEAK VARIATION FROM NORMAL	
	Key ON (kHz)	Key OFF (kHz)
t ₁	1.2	N/A
t ₂	0.4	N/A
t ₃	N/A	0.9
t ₂ → t ₃ ppm	0.9	
ERROR LIMIT (t ₂ → t ₃) ppm	5	

Confirm that during periods t ₁ and t ₃ the frequency difference does not exceed the value of one channel separation.	YES	NO
	Y	
Confirm that during the period t ₂ the frequency difference does not exceed half a channel separation.	YES	NO
	Y	
Confirm that during the period t ₂ to t ₃ the frequency difference does not exceed the frequency error limit.	YES	NO
	Y	

LIMIT:

TRANSIENT PERIODS	FREQUENCY RANGE 150MHz – 174 MHz	FREQUENCY RANGE 421MHz – 512 MHz
t ₁ (ms)	5 ms	10 ms
t ₂ (ms)	20 ms	25 ms
t ₃ (ms)	5 ms	10 ms

NAME OF TEST: TRANSIENT FREQUENCY BEHAVIOUR

SPECIFICATION: FCC 47 CFR 90.214

TX FREQUENCY: 480.1 MHz
25.0 kHz Channel Spacing 1 W

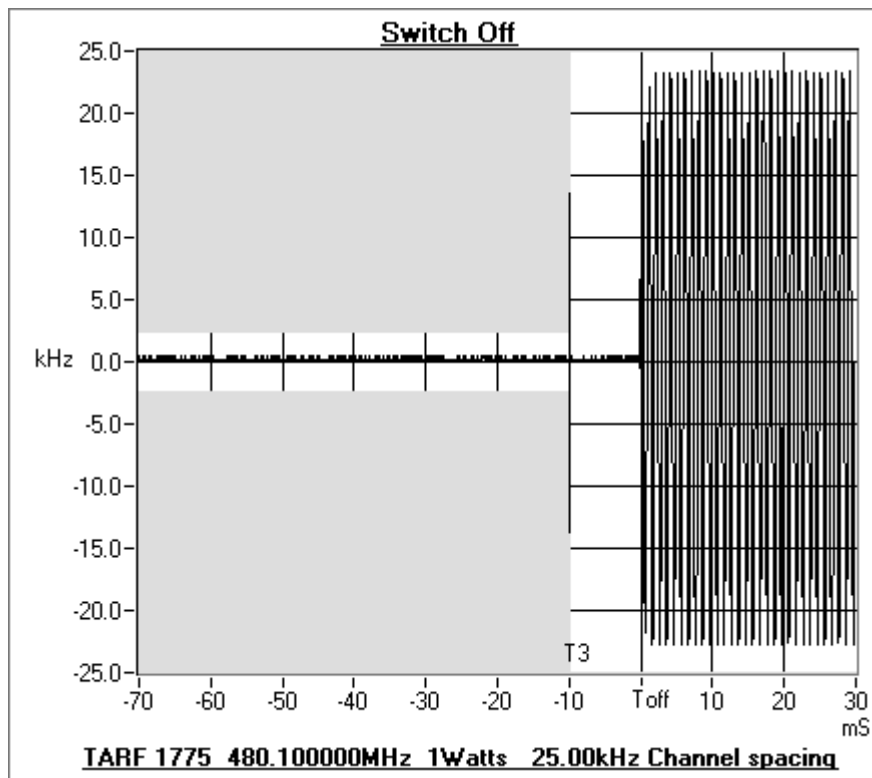
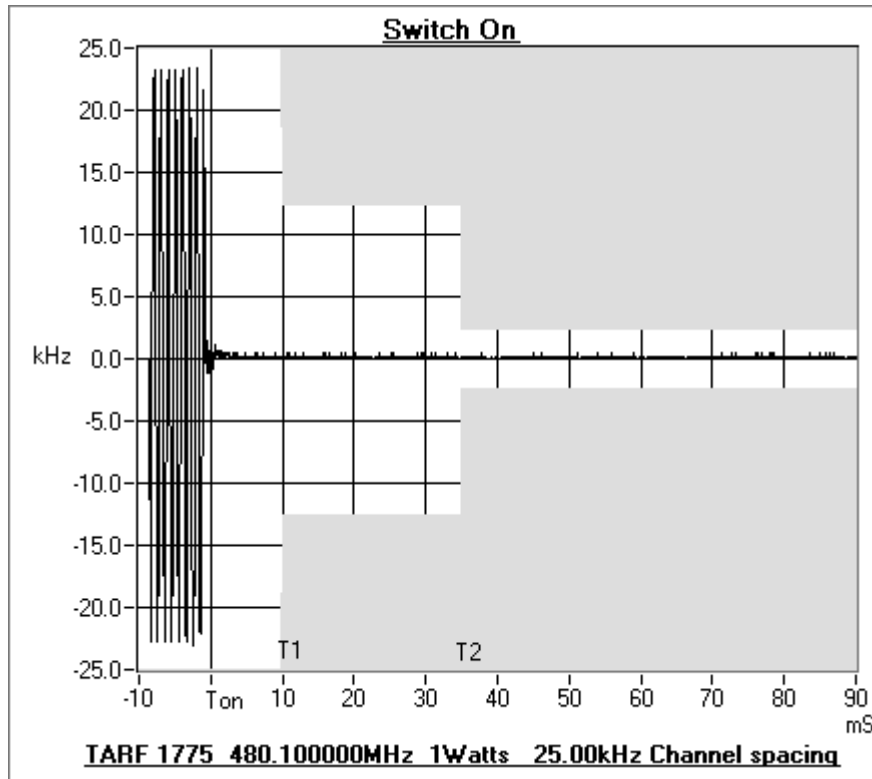

NAME OF TEST: TRANSIENT FREQUENCY BEHAVIOUR

TELTEST REPORT: 1775

TOP-I2410-T0

SPECIFICATION: FCC 47 CFR 90.214

TX FREQUENCY: 480.1 MHz

25.0 kHz Channel Spacing

FREQUENCY	480.1 MHz @ 4 W TX	
TRANSIENT RESPONSE PERIOD	CARRIER PEAK VARIATION FROM NORMAL	
	Key ON (kHz)	Key OFF (kHz)
t ₁	1.7	N/A
t ₂	0.5	N/A
t ₃	N/A	0.7
t ₂ → t ₃ ppm	1.0	
ERROR LIMIT (t ₂ → t ₃) ppm	5	

Confirm that during periods t ₁ and t ₃ the frequency difference does not exceed the value of one channel separation.	YES	NO
	✓	
Confirm that during the period t ₂ the frequency difference does not exceed half a channel separation.	YES	NO
	✓	
Confirm that during the period t ₂ to t ₃ the frequency difference does not exceed the frequency error limit.	YES	NO
	✓	

LIMIT:

TRANSIENT PERIODS	FREQUENCY RANGE 150MHz – 174 MHz	FREQUENCY RANGE 421MHz – 512 MHz
t ₁ (ms)	5 ms	10 ms
t ₂ (ms)	20 ms	25 ms
t ₃ (ms)	5 ms	10 ms

NAME OF TEST: TRANSIENT FREQUENCY BEHAVIOUR

SPECIFICATION: FCC 47 CFR 90.214

TX FREQUENCY: 480.1 MHz
25.0 kHz Channel Spacing 4 W

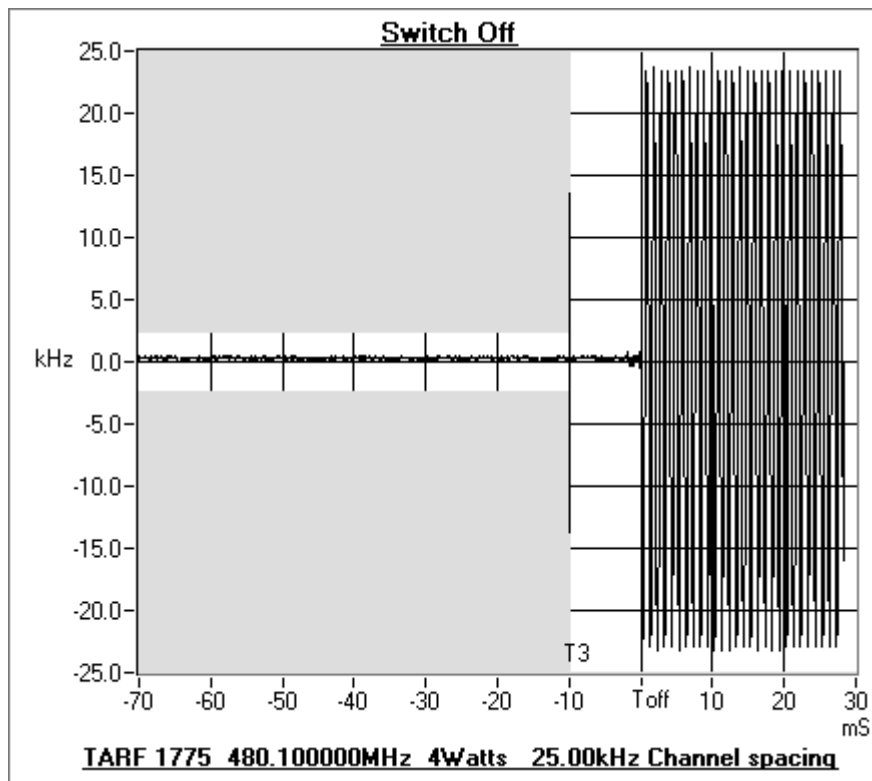
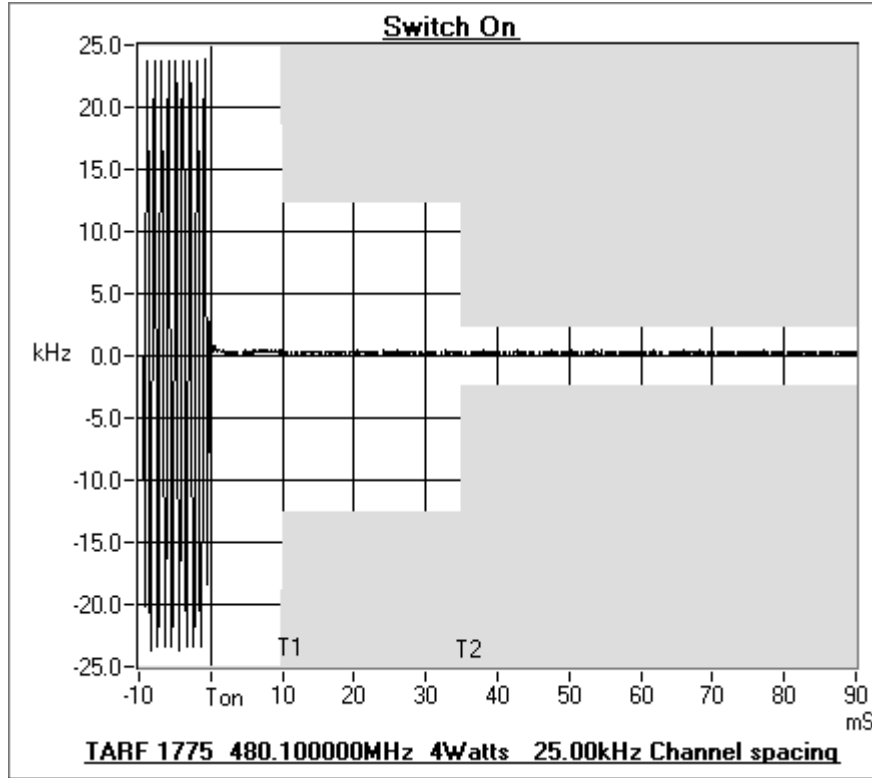

TEST EQUIPMENT LIST

To facilitate inclusion on each page, the test equipment used is identified (numbered) and listed against the related test in the report.

No.	Equipment Type	Model Number	Serial Number	Tait ID
01	Signal Generator	HP 8642B (Opt 001)	2512A00176	E3064
02	Signal Generator	HP 8648A	3430U00344	E3579
03	Signal Generator	Agilent E4422B	GB40050320	E3788
04	Signal Generator	HP 8648C	3443U00543	E3558
05	Signal Generator	SMY01 1062.5502.11	841736/019	E3553
10	Spectrum Analyser	HP 8596E (Opt 140)	3346A00213	E3427
11	Modulation Analyser	HP 8901B (Opt 002)	2441A00393	E3073
12	Modulation Analyser	FMA 0852.8500.52	842541/001	E3554
13	Audio Analyser	HP 8903A	2308A02597	E3074
14	Power Head	HP 11722A	2320A00688	E3307
15	Power Meter	NRVS 1020.1809.02	841954/005	E3555
16	Power Sensor	URV5-Z4 395.1619.55	841.498/003	E3557
20	Power Supply	HP 6032A	2441A-0041	E3075
21	Power Supply	NGSM32/10 192.0810.31	Fnr 434	E3556
22	Oscilloscope	Tektronics TDS 340	B13611	E3585
23	Universal Counter	Goldstar FC-2015U	600801	E3550
24	Environmental Chamber	Contherm Spatial Cal	E3397	E3397
24	Environmental Chamber	Contherm Temp Control	E3397	E3397
25	Portable Hygrometer (ASL)	Rotronic A1	2070300/38	N/A
25	Whirling Hygrometer	Casella 3156/82	TA004	TA004
30	Directional Coupler	HP 778D-012	1144 07392	E3292
31	4-Port Combiner (CAST)	DVU4, ¼ W201.4018.03	300729/47	E3623
32	4-Port Combiner	DVU4, ¼ W201.4018.03	300971/28	E3572
33	3-Port Combiner	Weinschel 1506A, 1W	LD858	E3672
34	Mixer Spurious Emission	Tait (3.2G ≤ Rfx ≤ 4.0G)	E3661	E3661
35	Mixer Transient ACP	Minicircuits ZAD-11	77031	E3394
36	Voltmeter	HP 3478A	2545A25838	E1559
37	Variac	Yamabishi S-260-5	TX-533	E1737
38	Rx & TX RF Paths	Tait CAST Interface	E3067	E3067
40	Reference Dipoles	Emco 3121C-DB1	9510-1164	E3559
41	Antenna	Biconical	9307-1680	E3033
42	Reference Horn Antenna	Emco DRG 3115	9512-4638	E3560
43	Horn Antenna	Emco DRG 3115	2084	E3076

No.	Equipment Type	Model Number	Serial Number	Tait ID
44	Corner 175 ~ 420 MHz	Ailtech DM 105A-T2	J1417-103	E3031
45	Corner 400 ~ 1000 MHz	Ailtech DM 105A-T3	J1418-108	E3036
46	S-LINE TEM CELL	1089.9296.02	338232/003	E3636
50	Amplifier AR 1M ~ 1000 MHz	25 W 1000A	20444	E3637
51	Amplifier AR 10k ~ 250 MHz	25A 250	16373	E3570
52	Amplifier +21.7dB	Tait ZFL-1000LN	E3660	E3660
53	RF Filter 21.4M (CAST)	Tait NDK 21G-6DT	E3069	E3069
54	RF Filter 21.4M (ACP)	Tait NDK 21G-6DT	RA-7'	E3249
55	Filter Notch	Tait		N/A
56	Filter High Pass	Tait	MHz	N/A
57	Filter Low Pass	Tait	MHz	N/A
60	RF Attenuator 250W	Weinschel 45-30-34	JW663	E3386
61	RF Attenuator 150W	Weinschel 40-20-33	CJ404	E3387
62	RF Attenuator 150W	Weinschel 57-10-34	LB590	E3674
63	RF Attenuator 150W	Weinschel 40-06-34	KV457	E3561
64	RF Attenuator 50W	Weinschel 24-10-34	AL0401	E3388
65	RF Attenuator 50W	Weinschel 24-20-44	AW1266	E3562
66	RF Attenuator 25W	Weinschel 33-20-33	BD5871	E3673
67	RF Attenuator 150W (CAST)	Weinschel 40-20-33	CJ405	3366/82
70	RF Load 150W	Byrd 8166	524	E3625
71	RF Load 50W	Weinschel F1426	BF0487	E3675
72	RF Load 50W	Weinschel F1426	AE2490	E3624
73	RF Termination 20 W	Deltec	118.001	E3626
74	RF Termination ½ W	MCL NTRM-50	951215	E3574
75	RF Termination ½ W	MCL NTRM-50	954214	E3575
76	RF Termination ½ W	MCL NTRM-50	954214	E3576
80	20 M Coax Cable	RG214/U 50 (Ext Cal)	CBL01	E3659
81	2 M Coax Cable	RG213/U 50 (Ext Cal)	CBL02	E3658
82	3 M Coax Cable (BLUE)	Suhner Sucoflex 104A	25033/4A	E3694
83	1 M Coax Cable (BLUE)	Suhner Sucoflex 104A	25006/4A	E3693
84	1 M Coax Cable (BLUE)	Suhner Sucoflex 104A	25005/4A	E3692
85	1 M Coax Cable (BLUE)	Suhner Sucoflex 104A	25004/4A	E3691
86	1 M Coax Cable (BLUE)	Suhner Sucoflex 104A	25003/4A	E3690
87	Audio Analyser	HP 8903B	2818A04275	E3710
88	Spectrum Analyser	HP 8562E	3821A00799	E3715
89	Field Strength Meter	Holaday HI-422	95661	E3630
90	Power Supply	HP 6012B	2524A00616	E3712

No.	Equipment Type	Model Number	Serial Number	Tait ID
91	20 M Coax Cable	RG214/U 50 (Ext Cal)	3404	24/8/99
92	LISN	EMCO 3825/2	9204-1961	E3040
93	Oscilloscope	Tektronix TDS 380	B017095	E3782
94				
95	Modulation Analyser	HP 8901B	3704A05837	E3786
93	EMC Test Instr	BEST +A	199825-010SC	AT183
94	ESD Test Set	PSD 25B	082 999 24	E3629
95	Vehicle Conducted Immunity Test Set	NSG 5000	IN5094-090	E3506
96	Burst Generator	NSG5003	AR5194-151	E3508
97	Battery Simulator	NSG 5004	IN1695-003	-
98	RF Injection Probe	F120-9	121	-
99	BER Meter	5000	9405003	-
100	Oscilloscope	TDS380	B017095	E3782
101	Coupler Decoupler Network	S15	10344	E3563
102	Coupler Decoupler Network	S1/50	10328	E3564
103	Coupler Decoupler Network	AF2	10967	E3565
104	Coupler Decoupler Network	M3-1	12207	E3566
105	Coupler Decoupler Network	S25	10762	E3567
105	Coupler Decoupler Network	T2	10778	E3568
106	Coupler Decoupler Network	M2	10701	E3569
107	Benchlink	E4444A Ver A.01.06	19980701	-
108	GPIB Software	Ver 1.6	500739A-00	-
109	Labview	Ver 5.1.1	500573J-00	-
110	Wavestar	WSTR31 Ver 2.4	063-2173-04	-
111	Modulation Analyser	HP8901B (Opt 002)	3704A05837	E3786
112	Signal Generator	ESG4000B	GB40050320	E3788
113	Hi Level Mixer			E3933
114	Signal Generator	SML03 1090.3000.13	100597	E4050
115	Environ. Chamber	5400 RHSLT.M	1416	E4051
116	Power Head	HP11722A	2716A02037	1575
117	RF Attenuator	Weinschel Model 1	BL9950	-
118	RF Attenuator	Weinschel Model 1	BL9958	-
119	RF Attenuator 150W	Weinschel 40-20-23	MF817	-
120	RF Splitter Combiner	Minicircuits ZFSC-4-1	-	-
121	RF Splitter Combiner	Minicircuits ZFSC-4-1	-	-
122	RF Splitter Combiner	Minicircuits ZFSC-4-1	-	-