

## 3 T856/857 Initial Tuning & Adjustment



**Caution:** This equipment contains CMOS devices which are susceptible to damage from static charges. Refer to [Section 1.2](#) in Part A for more information on anti-static procedures when handling these devices.

The following section describes both short and full tuning and adjustment procedures and provides information on:

- channel programming
- selecting required audio links
- synthesiser alignment
- PA alignment (T856 only)
- modulator adjustment
- limiter adjustment
- setting line level
- compressor adjustment
- timer adjustment.

**Note:** Unless otherwise specified, the term "PGM800Win" used in this and following sections refers to version 2.00 and later of the software.

Refer to [Figure 4.4](#) and [Figure 4.5](#) which show the location of the main tuning and adjustment controls. Refer also to Section 6 where the parts lists, grid reference index and diagrams will provide detailed information on identifying and locating components and test points on the main PCB. The parts list and diagrams for the VCO PCB are in Part E.

Section	Title	Page
3.1	Introduction	3.3
3.2	Channel Programming	3.3
3.3	Test Equipment Required	3.4
3.4	Short Tuning Procedure	3.5
3.4.1	Introduction	3.5
3.4.2	Synthesiser Alignment	3.5
3.4.3	Output Power Adjustment (T856 Only)	3.5
3.4.4	Two Point Modulation Adjustment	3.6
3.4.5	CTCSS Encoder (If Used)	3.7
3.4.6	FM Deviation (Limiter) Adjustment	3.7
3.4.7	Line-in Level Adjustment	3.7

Section	Title	Page
3.5	<b>Audio Processor Links</b>	<b>3.8</b>
3.5.1	Link Details	3.8
3.5.2	Typical Options	3.8
3.6	<b>Synthesiser Alignment</b>	<b>3.9</b>
3.7	<b>PA Alignment (T856 Only)</b>	<b>3.10</b>
3.8	<b>Thermal Shutdown (T856 Only)</b>	<b>3.10</b>
3.9	<b>Audio Processor &amp; CTCSS</b>	<b>3.11</b>
3.9.1	Two Point Modulation	3.11
3.9.2	Modulator Adjustment	3.11
3.9.3	CTCSS Encoder (If Used)	3.12
3.9.4	Limiter Adjustment	3.12
3.9.5	Line Level Without Compressor	3.13
3.9.6	Compressor	3.13
3.9.6.1	Compressor On Line Input Only	3.13
3.9.6.2	Compressor On Microphone Input Only	3.13
3.9.6.3	Compressor On Both Line & Microphone Inputs	3.14

Figure	Title	Page
3.1	T856/857 Test Equipment Set-up With T800-01-0010	3.4
3.2	T856/857 Test Equipment Set-up Without T800-01-0010	3.4

## 3.1 Introduction

When you receive your T856 transmitter or T857 exciter it will be run up and working on a particular frequency (the "default channel")<sup>1</sup>. If you want to switch to a frequency that is within the 8MHz switching range (i.e.  $\pm 4$ MHz from the factory programmed frequency), you should only need to reprogram the transmitter/exciter with the PGM800Win software (refer to the PGM800Win programming kit and [Section 3.2](#) below).

However, if you want to switch to a frequency outside the 8MHz switching range, you will have to reprogram and re-tune the transmitter/exciter to ensure correct operation. In this case you should carry out the short tuning procedure described in [Section 3.4](#).

If you have carried out repairs or other major adjustments, you must carry out the full tuning and adjustment procedure described in this section (except for [Section 3.4](#)).

## 3.2 Channel Programming

You can program up to 128 channel frequencies into the transmitter/exciter's EEPROM memory (IC820) by using the PGM800Win software package and an IBM™ PC. You can also use PGM800Win to select the transmitter/exciter's current operating frequency (or "default channel").

If the transmitter/exciter is installed in a rack frame, you can program it via the programming port in the speaker panel. However, you can also program the transmitter/exciter before it is installed in a rack frame as follows:

- by using a T800-01-0010 calibration test unit;
- via D-range 1;
- via D-range 2 (standard T800-03-0000 auxiliary D-range only);
- via SK805 (internal Micromatch connector).

If you do not use the T800-01-0010, you will have to connect the PC to the transmitter/exciter via a module programming interface (such as the T800-01-0004).

For a full description of the channel programming procedure, refer to the PGM800Win programming software user's manual.

**Note:** When an auxiliary D-range kit (D-range 2 - T800-03-0000) is fitted, you can also select a channel with an external switch, such as the DIP switch on the rack frame backplane PCB. Refer to Part C in the T800 Series Ancillary Equipment Service Manual (M800-00-101 or later issue) or consult your nearest Tait Dealer or Customer Service Organisation for further details.

---

1. Use the "Read Module" function in PGM800Win to find out what the default channel is.

### 3.3 Test Equipment Required

You will need the following test equipment:

- computer with PGM800Win installed
  - T800 programming kit
  - module programming interface (e.g. T800-01-0004 - optional)
  - 13.8V power supply
  - digital multimeter
  - audio signal generator
  - RF power meter
  - audio voltmeter x 2
  - modulation meter
  - oscilloscope (digital preferred)
  - 20dB or 40dB pad
  - T800-01-0010 calibration test unit (optional)
- } or RF test set (optional)

Figure 3.1 and Figure 3.2 show typical test equipment set-ups.

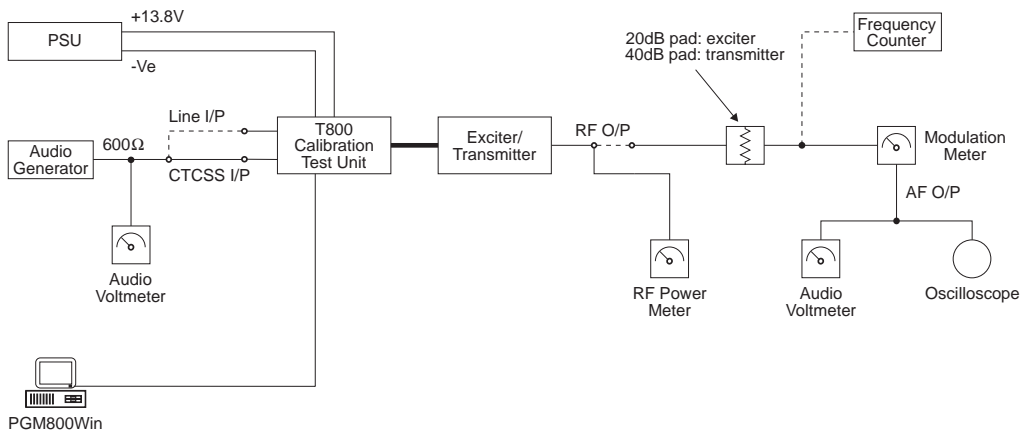

Figure 3.1 T856/857 Test Equipment Set-up With T800-01-0010

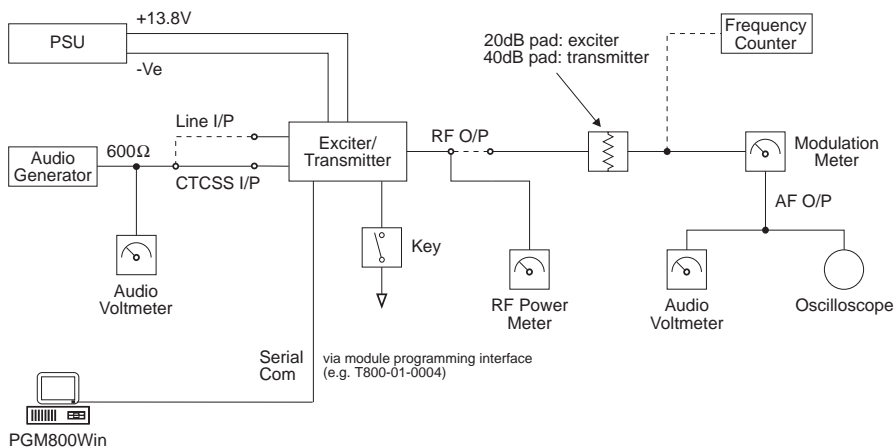

Figure 3.2 T856/857 Test Equipment Set-up Without T800-01-0010

## 3.4 Short Tuning Procedure

Use this procedure only if you want to reprogram the T856/857 to a frequency outside the 8MHz switching range and do not intend to carry out any other major adjustments or repairs.

### 3.4.1 Introduction

Reprogram the operating frequency as described in the PGM800Win programming kit (refer to [Section 3.2](#)).

Remove the top cover (nearest the handle).

Set up the test equipment as described in [Section 3.3](#).

Set the links in the audio processor section as required (refer to [Section 3.5](#)).

### 3.4.2 Synthesiser Alignment

- Connect a high impedance voltmeter to the long lead of L1 in the VCO (this measures the synthesiser loop voltage).
- Key the transmitter by earthing the Tx-Key line.
- **Single Channel**      Tune VCO trimmer C6 for a synthesiser loop voltage of 10V.
- **Multichannel**      Tune VCO trimmer C6 for a synthesiser loop voltage of 10V on the middle channel.  
If there is no middle channel, tune C6 so that the channels are symmetrically placed around a loop voltage of 10V.  
All channels should lie within the upper and lower limits of 16V and 3V respectively.  
Do not attempt to program channels with a greater frequency separation than the specified switching range of 8MHz.

### 3.4.3 Output Power Adjustment (T856 Only)

Connect an RF power meter with suitable attenuation to the output socket and key the transmitter.

Turn RV310 (power control) fully clockwise.

Tune #CV475 (output power trim) for maximum output power and check that this is >30W.

Adjust RV310 for the required output power (between 5 and 25W).

Readjust #CV475 to reduce the supply current by up to 0.5A.

### 3.4.4 Two Point Modulation Adjustment

**Note 1:** In this and following sections deviation settings are given first for wide bandwidth sets, followed by settings in brackets for mid bandwidth sets ( ) and narrow bandwidth sets [ ].

**Note 2:** The reference modulation and limiter adjustments are controlled by 256-step electronic potentiometers (EPOTs), which are adjusted via the “Reference Modulation” and “Deviation” settings in PGM800Win. This allows the two point modulation and deviation settings to be adjusted for each channel.

**Note 3:** To optimise the modulation response across the switching range, repeat steps 1-4 below for each channel that will be used (usually needed only for data applications). In applications where the modulation response is less critical (e.g. voice use only), carry out steps 1-4 below on the middle channel and use the “EPOT Fill” option<sup>1</sup> in PGM800Win to copy the value to the other channels.

**Note 4:** If you are using an RF test set, turn the low pass filter off and set the high pass filter to 15kHz *before* beginning this procedure.

1. Inject an audio signal of 300Hz 1.5V rms (+5dBm) into the CTCSS input (D-range 1 (PL100) pin 8).

Key the transmitter by earthing the Tx-Key line.

2. Adjust the output from the audio generator to obtain  $\pm 3\text{kHz}$  ( $\pm 2.4\text{kHz}$ ) [ $\pm 1.5\text{kHz}$ ] deviation at 300Hz.

3. Change the input frequency to 100Hz and, using PGM800Win, adjust the value of the “Reference Modulation” EPOT setting for the current channel to obtain  $\pm 3\text{kHz}$  ( $\pm 2.4\text{kHz}$ ) [ $\pm 1.5\text{kHz}$ ] deviation (you can use either the mouse or up and down arrow keys).

4. Change the input frequency back to 300Hz.

Repeat steps 2 and 3 above until the deviations achieved at the two input frequencies are within 0.2dB of each other. You will need to do this at least four times.

5. Sweep the audio between 50 and 300Hz for peaks.

**Note:** A peak between 50 and 300Hz will indicate a fault condition, i.e:

- incorrect set-up
- or - modulation circuitry fault.

The specification window is  $\pm 1\text{dB}$  relative to 150Hz from 67 to 260Hz.

---

1. Use the “EDIT FILL” button on the tool bar or go to “Edit”, “Fill”, “Epot Settings” on the menu bar.

### 3.4.5 CTCSS Encoder (If Used)

Program a CTCSS tone on the default channel using PGM800Win.

If you are using an RF test set, turn off the 300Hz high pass filter.

Key the T856/857 with the front panel "Carrier" switch.

Adjust RV805 (CTCSS level adjust) to give  $\pm 500\text{Hz}$  ( $\pm 350\text{Hz}$ ) [ $\pm 250\text{Hz}$ ] deviation.

Set the maximum deviation as per [Section 3.4.6](#).

### 3.4.6 FM Deviation (Limiter) Adjustment

**Note:** If the T856/857 will be used over the whole 8MHz switching range, you must set the deviation for each channel. However, if the module will be used on frequencies that cover only a 1MHz (or less) switching range, you can set the deviation on the middle channel and use this value for all other channels with the "EPOT Fill" option in PGM800Win.

Inject 1kHz at -10dBm into the line input (D-range 1 (PL100) pins 1 & 4; pins 2 & 3 shorted; refer to [Section 2.2](#) of Part F).

Adjust RV210 (line sensitivity) fully clockwise and key the transmitter by earthing the Tx-Key line. Using PGM800Win, adjust the value of the "Deviation" EPOT setting for the current channel to obtain a deviation limit of  $\pm 4.7\text{kHz}$  ( $\pm 3.8\text{kHz}$ ) [ $\pm 2.3\text{kHz}$ ] (you can use either the mouse or up and down arrow keys).

Sweep the audio frequency from 100Hz to 4kHz and ensure that the maximum deviation does not exceed  $\pm 4.7\text{kHz}$  ( $\pm 3.8\text{kHz}$ ) [ $\pm 2.3\text{kHz}$ ]. Readjust "Deviation" if necessary via PGM800Win.

### 3.4.7 Line-in Level Adjustment

Remove the CTCSS signal (if used).

Set the injected signal at the line input to the required line level (typically -10 to -20dBm).

Adjust RV210 (line sensitivity) to provide  $\pm 3\text{kHz}$  ( $\pm 2.4\text{kHz}$ ) [ $\pm 1.5\text{kHz}$ ] deviation.

Reapply the CTCSS signal (if required).

## 3.5 Audio Processor Links

### 3.5.1 Link Details

Use the following table to set up the audio processor to the configuration you require. You should set the audio processor links before carrying out any of the tuning and adjustment procedures. The factory settings are shown in brackets [ ].

Plug	Link <sup>a</sup>	Function
PL205	1-2 A	not connected
	[3-4] B	microphone pre-amp. output to compressor input
	5-6 C	microphone pre-amp. output to multiplexer input
PL210	[1-2] L	multiplexer output to pre-emphasis input
	3-4 M	multiplexer output to limiter input
	5-6 N	multiplexer output to compressor input
PL215	1-2 G	not connected
	[3-4] H	compressor output to multiplexer input
	5-6 I	compressor output to limiter input
	7-8 J	compressor output to pre-emphasis input
	9-10 K	not connected
PL220	1-2 D	pre-emphasis output to multiplexer input
	[3-4] E	pre-emphasis output to limiter input
	5-6 F	not connected

- a. The letters in this column and in the table in [Section 3.5.2](#) below refer to the identification letters screen printed onto the PCB beside each pair of pins.

### 3.5.2 Typical Options

	PL205	PL210	PL215	PL220
microphone pre-amp. compressed and pre-emphasised; line input pre-emphasised (standard set-up)	[3-4] B	[1-2] L	[3-4] H	[3-4] E
microphone pre-amp. compressed and pre-emphasised; line input unprocessed	3-4 B	3-4 M	7-8 J	1-2 D
line and microphone compressed and pre-emphasised	5-6 C	5-6 N	7-8 J	3-4 E
microphone pre-amp. compressed; line and microphone flat response	3-4 B	3-4 M	3-4 H	5-6 F



## 3.6 Synthesiser Alignment

- Ensure that the T856/857 has been programmed with the required frequencies using PGM800Win software.
- **Single Channel**      Select a channel using PGM800Win.  
**Multichannel**      Select the middle channel via PGM800Win.
- Connect a high impedance voltmeter to the long lead of L1 in the VCO (this measures the synthesiser loop voltage).
- Key the transmitter by earthing the Tx-Key line.
  - Single Channel**      Tune VCO trimmer C6 for a synthesiser loop voltage of 10V.
  - Multichannel**      Tune VCO trimmer C6 for a synthesiser loop voltage of 10V on the middle channel.

If there is no middle channel, tune C6 so that the channels are symmetrically placed around a loop voltage of 10V.

All channels should lie within the upper and lower limits of 16V and 3V respectively.

Do not attempt to program channels with a greater frequency separation than the specified switching range (8MHz).
- Check that the exciter output power is 1W  $\pm$ 300mW (**T857 only**).
- Measure the exciter output frequency and adjust the TCXO (=IC700) trimmer if required.



**Caution:** This trimmer is susceptible to physical damage. Do not exert a downward force of more than 500g (1lb) when adjusting.

## 3.7 PA Alignment (T856 Only)

Check that the exciter is connected to the PA with the coaxial link.

Connect an RF power meter to the PA output (use an appropriate attenuator as necessary).

Turn RV310 (power control) fully clockwise.

**Note:** Before the following measurement is taken, ensure the heatsink is at ambient temperature (20-25°C).

Measure and record the voltage (VL) at L481; perform this measurement at room temperature so that the NTC (R481) is close to 25°C.

Key the transmitter by earthing the Tx-Key line.

Tune #CV475 until maximum power is obtained. Check that the power exceeds 30W.

Adjust RV310 (power control) to 25W.

Readjust #CV475 to reduce the supply current by up to 0.5A.

## 3.8 Thermal Shutdown (T856 Only)

Key the transmitter by earthing the Tx-Key line and set the output power to 25W as described in [Section 3.7](#).

Short L481 to ground.

Set RV330 (shutdown power level) for an output power of 5W.

Set RV320 (shutdown temperature) to 0.16VL volts (measured at IC350 pin 3), where VL is the voltage measured at L481 in [Section 3.7](#). This sets the thermal shutdown at 85°C at NTC R481.

## 3.9 Audio Processor & CTCSS

### 3.9.1 Two Point Modulation

The T856 and T857 utilise two point modulation to obtain a wide audio bandwidth independent of the synthesiser loop filter response. This is achieved by simultaneously frequency modulating the VCO and phase modulating the synthesiser reference frequency. The relative signal levels fed to the two modulators are quite critical and cause interaction when setting up.

Both modulating signals require readjustment when the exciter is shifted in frequency greater than the switching range (i.e.  $\Delta F > \pm 4\text{MHz}$ ).

**Note 1:** In this and following sections deviation settings are given first for wide bandwidth sets, followed by settings in brackets for mid bandwidth sets ( ) and narrow bandwidth sets [ ].

**Note 2:** The reference modulation and limiter adjustments are controlled by 256-step electronic potentiometers (EPOTs), which are adjusted via the “Reference Modulation” and “Deviation” settings in PGM800Win. This allows the two point modulation and deviation settings to be adjusted for each channel.

**Note 3:** To optimise the modulation response across the switching range, repeat steps 1-4 below for each channel that will be used (usually needed only for data applications). In applications where the modulation response is less critical (e.g. voice use only), carry out steps 1-4 below on the middle channel and use the “EPOT Fill” option<sup>1</sup> in PGM800Win to copy the value to the other channels.

**Note 4:** If you are using an RF test set, turn the low pass filter off and set the high pass filter to 15kHz *before* beginning this procedure.

### 3.9.2 Modulator Adjustment

1. Inject an audio signal of 300Hz 1.5V rms (+5dBm) into the CTCSS input (D-range 1 (PL100) pin 8).

Key the transmitter by earthing the Tx-Key line.

2. Adjust the output from the audio generator to obtain  $\pm 3\text{kHz}$  ( $\pm 2.4\text{kHz}$ ) [ $\pm 1.5\text{kHz}$ ] deviation at 300Hz.
3. Change the input frequency to 100Hz and, using PGM800Win, adjust the value of the “Reference Modulation” EPOT setting for the current channel to obtain  $\pm 3\text{kHz}$  ( $\pm 2.4\text{kHz}$ ) [ $\pm 1.5\text{kHz}$ ] deviation (you can use either the mouse or up and down arrow keys).

- 
1. Use the “EDIT FILL” button on the tool bar or go to “Edit”, “Fill”, “Epot Settings” on the menu bar.

4. Change the input frequency back to 300Hz.  
Repeat steps 2 and 3 above until the deviations achieved at the two input frequencies are within 0.2dB of each other. You will need to do this at least four times.
5. Sweep the audio between 50 and 300Hz for peaks.

**Note:** A peak between 50 and 300Hz will indicate a fault condition, i.e:

- incorrect set-up
- or - modulation circuitry fault.

The specification window is  $\pm 1$ dB relative to 150Hz from 67 to 260Hz.

### 3.9.3 CTCSS Encoder (If Used)

Program a CTCSS tone on the default channel using PGM800Win.

If you are using an RF test set, turn off the 300Hz high pass filter.

Key the T856/857 with the front panel "Carrier" switch.

Adjust RV805 (CTCSS level adjust) to give  $\pm 500$ Hz ( $\pm 350$ Hz) [ $\pm 250$ Hz] deviation.

Set the maximum deviation as per [Section 3.9.4](#).

### 3.9.4 Limiter Adjustment

**Note:** If the T856/857 will be used over the whole 8MHz switching range, you must set the deviation for each channel. However, if the module will be used on frequencies that cover only a 1MHz (or less) switching range, you can set the deviation on the middle channel and use this value for all other channels with the "EPOT Fill" option in PGM800Win.

Set the links in the audio processor section as required (refer to [Section 3.5](#)).

Inject 1kHz at -10dBm into the line input (D-range 1 (PL100) pins 1 & 4; and pins 2 & 3 shorted; refer to [Section 2.2](#) of Part F).

Adjust RV210 (line sensitivity) fully clockwise and key the transmitter by earthing the Tx-Key line. Using PGM800Win, adjust the value of the "Deviation" EPOT setting for the current channel to obtain a deviation limit of  $\pm 4.7$ kHz ( $\pm 3.8$ kHz) [ $\pm 2.3$ kHz] (you can use either the mouse or up and down arrow keys).

Sweep the audio frequency from 100Hz to 4kHz and ensure that the maximum deviation does not exceed  $\pm 4.7$ kHz ( $\pm 3.8$ kHz) [ $\pm 2.3$ kHz]. Readjust "Deviation" if necessary via PGM800Win.

### 3.9.5 Line Level Without Compressor

This section assumes that the compressor is not used. If the compressor is required, refer to [Section 3.9.6](#).

Remove the CTCSS signal (if used).

Adjust the line sensitivity as follows:

- set the injected signal at the line input to the required line level (typically -10 to -20dBm);
- adjust RV210 (line sensitivity) to provide  $\pm 3\text{kHz}$  ( $\pm 2.4\text{kHz}$ ) [ $\pm 1.5\text{kHz}$ ] deviation.

Reapply the CTCSS signal (if required).

### 3.9.6 Compressor

The compressor may be used on the line input only, the microphone input only, or on both the line and microphone inputs. If the compressor is used, refer to one of the following sections as appropriate.

#### 3.9.6.1 Compressor On Line Input Only

Set RV210 (line sensitivity) fully clockwise and key the transmitter by earthing the Tx-Key line.

Reduce the line level to -50dBm at 1kHz and set RV220 (compression level) fully clockwise.

Check that  $\pm 3\text{kHz}$  deviation ( $\pm 2.4\text{kHz}$ ) [ $\pm 1.5\text{kHz}$ ] is still available.

Slowly increase the audio input level until the demodulated waveform shows significant signs of clipping (approximately  $\pm 4.5\text{kHz}$  ( $\pm 3.6\text{kHz}$ ) [ $\pm 2.3\text{kHz}$ ] deviation).

Adjust RV220 anticlockwise until the demodulated waveform is just clipping (approximately  $\pm 4\text{kHz}$  ( $\pm 3.2\text{kHz}$ ) [ $\pm 2\text{kHz}$ ] deviation).

Increase the input level to -10dBm and check that the test tone is still held just into clipping. The input line level should be typically -10 to -20dBm.

#### 3.9.6.2 Compressor On Microphone Input Only

Key the transmitter by earthing the Tx-Key line and plug a microphone jack into the front panel socket.

Adjust RV220 (compression level) fully clockwise.

Acoustically couple the microphone to a tone box (1kHz) and close the PTT switch.

Increase the audio level until the demodulated waveform shows significant signs of clipping (approximately  $\pm 4.5\text{kHz}$  ( $\pm 3.6\text{kHz}$ ) [ $\pm 2.3\text{kHz}$ ] deviation).

Adjust RV220 anticlockwise until the demodulated waveform is just clipping (approximately  $\pm 4\text{kHz}$  ( $\pm 3.2\text{kHz}$ ) [ $\pm 2\text{kHz}$ ] deviation).

Increase the audio level by 10dB and verify that the test tone is held just into clipping.

Whistle steadily into the microphone, checking that approximately  $\pm 4\text{kHz}$  ( $\pm 3.2\text{kHz}$ ) [ $\pm 2\text{kHz}$ ] deviation is produced. The modulated waveform should be basically sinusoidal.

Speak into the microphone, checking that the modulation peaks reach about  $\pm 5\text{kHz}$  ( $\pm 4\text{kHz}$ ) [ $\pm 2.5\text{kHz}$ ] deviation.

As the line is to be used without compression, set RV210 (line sensitivity) as described in [Section 3.9.5](#).

### **3.9.6.3 Compressor On Both Line & Microphone Inputs**

Set up as described in [Section 3.9.6.1](#).