

REPORT NUMBER 1545

SEPTEMBER 2000

RADIO PERFORMANCE MEASUREMENTS

On the T839-20-0000 Base Station Transmitter

FCC ID: CASTEL0038

SN: 706076

In accordance with

FCC 47 CFR Parts 22 and 90

PREPARED BY: Garry Pringle

Test Technician

CHECKED & APPROVED BY: SA Crompton

Laboratory Manager

TELTEST LABORATORIES

Tait Electronics Ltd
PO Box 1645
558 Wairakei Road
Christchurch 8005
New Zealand

Phone: +64-3-3583399

Fax: +64-3-3580432

TABLE OF CONTENTS

TEST	PAGE
TRANSMITTER OUTPUT POWER (CONDUCTED)	3
AUDIO FREQUENCY FILTER	4
TRANSMITTER AUDIO FREQUENCY RESPONSE	5
MODULATION LIMITING	7
MODULATION LIMITING (STEADY STATE and INSTANTANEOUS)	9
OCCUPIED BANDWIDTH	11
SPURIOUS EMISSIONS (CONDUCTED)	14
SPURIOUS EMISSIONS (RADIATED)	17
TRANSMITTER FREQUENCY STABILITY (TEMPERATURE)	20
TRANSMITTER FREQUENCY STABILITY (VOLTAGE)	22
TRANSIENT FREQUENCY BEHAVIOUR	23
LIST OF TEST EQUIPMENT	28

NAME OF TEST: TRANSMITTER OUTPUT POWER (CONDUCTED)

TEST CONDITIONS: Ambient Temperature 19°C
 Relative Humidity 45%
 Standard Voltage 120V AC

SPECIFICATION: FCC 47 CFR 2.1046

GUIDE: TIA/EIA-603 2.2.1

MEASUREMENT PROCEDURE:

1. The Equipment Under Test (EUT) was set up as shown on the following diagram.
2. The coaxial attenuator used has an impedance of 50 Ohms.
3. The unmodulated output power was measured with an RF Power meter.

MEASUREMENT RESULTS:

Manufacturer's Rated Output Power: Continuously Variable 20W to 100W

161.0025 MHz	100 W nominal	20 W nominal
POWER (W)	100.05	19.82
Variation from Nominal (%)	+0.05	-0.9
Measurement Uncertainty (dB)	+0.63 -0.68	

LIMIT CLAUSE: FCC 47 CFR 90.205

Radio Type: Base Station
 Frequency Band: 150MHz ~ 174MHz

- (n) The output power shall not exceed by more than 20% the manufacturer's rated output power for the particular transmitter.

TEST SETUP: See page 28 for Test Equipment information.

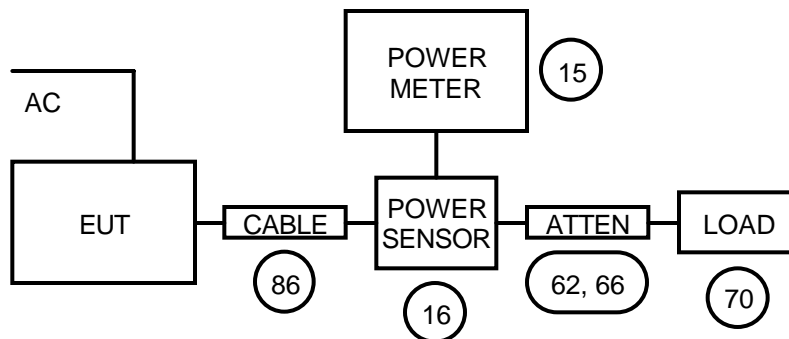

NAME OF TEST: AUDIO FREQUENCY FILTER RESPONSE

TEST CONDITIONS: Ambient Temperature °C
Relative Humidity %
Standard Voltage 120V AC

SPECIFICATION: FCC 47 CFR 2.1047

GUIDE: TIA/EIA-603 2.2.15

MEASUREMENT PROCEDURE:

This test was not carried out as the EUT meets the emission limits specified in §90.210.

MEASUREMENT RESULTS:

See Occupied Bandwidth tests on page 11.

LIMIT CLAUSE: FCC 47 CFR 90.211 (a)

(a) Transmitters utilizing analog emissions that are equipped with an audio low-pass filter must meet the emission limitations specified in §90.210....

TEST SETUP: See page 11 – Occupied Bandwidth

NAME OF TEST: TRANSMITTER AUDIO FREQUENCY RESPONSE
PRE-EMPHASIS

TEST CONDITIONS: Ambient Temperature 21°C
Relative Humidity 65%
Standard Voltage 120V AC

SPECIFICATION: FCC 47 CFR 2.1047 (a)

GUIDE: TIA/EIA-603 2.2.6

MEASUREMENT PROCEDURE:

1. The Equipment Under Test (EUT) was set up as shown on the following diagram.
2. An audio input tone of 1000Hz was applied with the level set to obtain 20% of maximum deviation. This was used as the 0dB reference point.
3. The AF was varied while the input level was held constant.
4. The response in dB relative to 1000Hz was measured.

MEASUREMENT RESULTS: See the plot on the following page.

LIMIT CLAUSE: TIA/EIA-603 4.2.6

TEST SETUP: See page 28 for Test Equipment information.

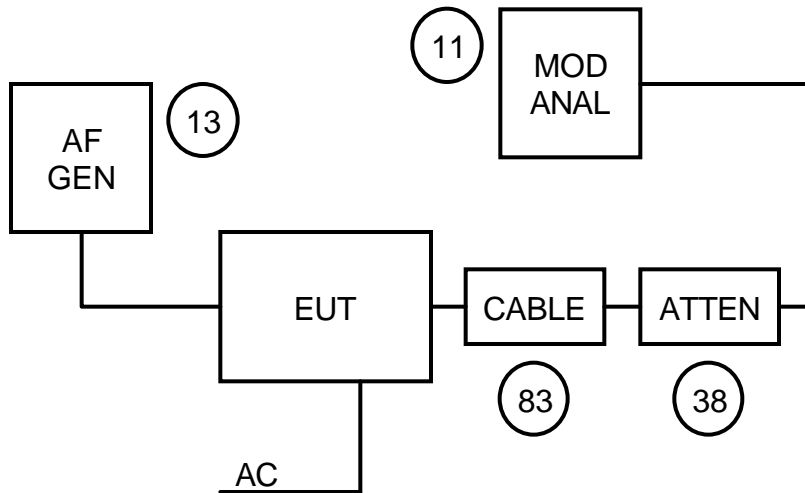

NAME OF TEST: TRANSMITTER AUDIO FREQUENCY RESPONSE
PRE-EMPHASIS

SPECIFICATION: FCC CFR 2.1047 (a)

Tx FREQUENCY: 161.0025 MHz

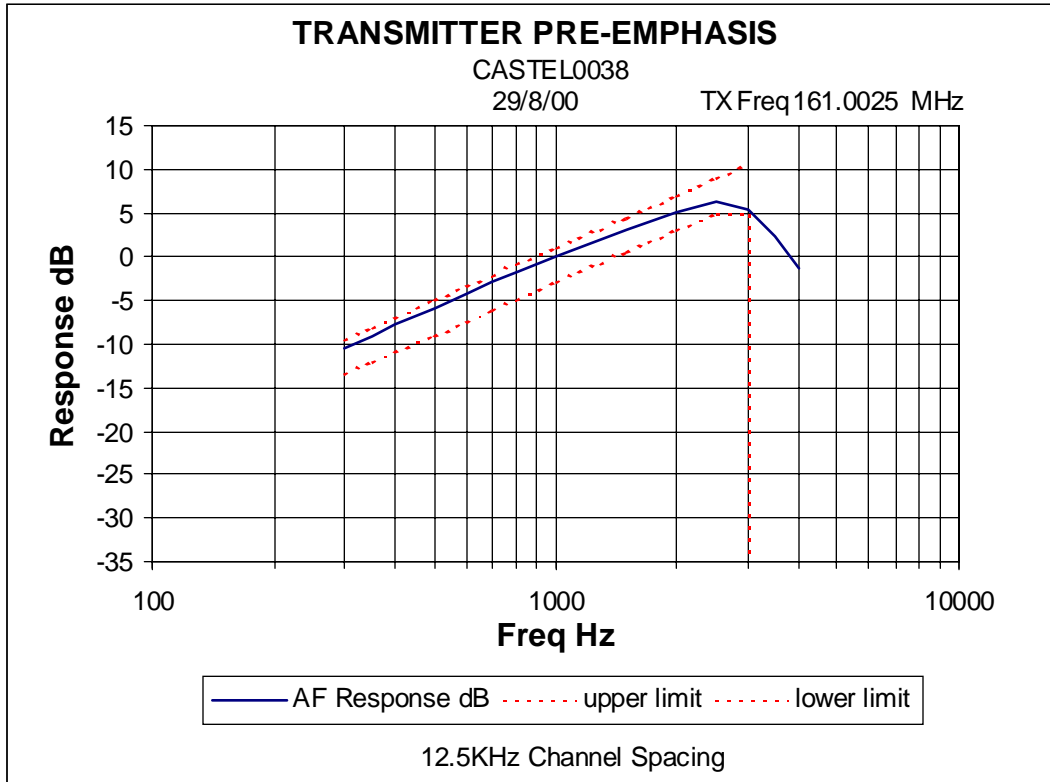

NAME OF TEST: TRANSMITTER MODULATION LIMITING

TEST CONDITIONS: Ambient Temperature 21°C
 Relative Humidity 65%
 Standard Voltage 120V AC

SPECIFICATION: FCC 47 CFR 2.1047 (b)

GUIDE: TIA/EIA-603 2.2.3

MEASUREMENT PROCEDURE:

1. The EUT was set up as shown on the following diagram.
2. The modulation response was measured at three audio frequencies while varying the input level.
3. Measurements were made for both Positive and Negative Deviation.

MEASUREMENT RESULTS: See the plots on the following page.

LIMIT CLAUSE: FCC 47 CFR 90.211 (a)

TEST SETUP: See page 28 for Test Equipment information.

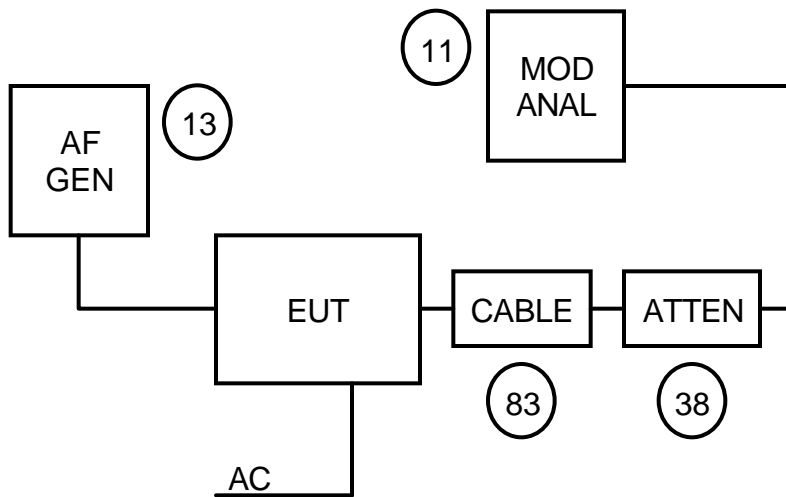

NAME OF TEST: TRANSMITTER MODULATION LIMITING

SPECIFICATION: FCC CFR 2.1047 (b)

Tx FREQUENCY: 161.0025 MHz

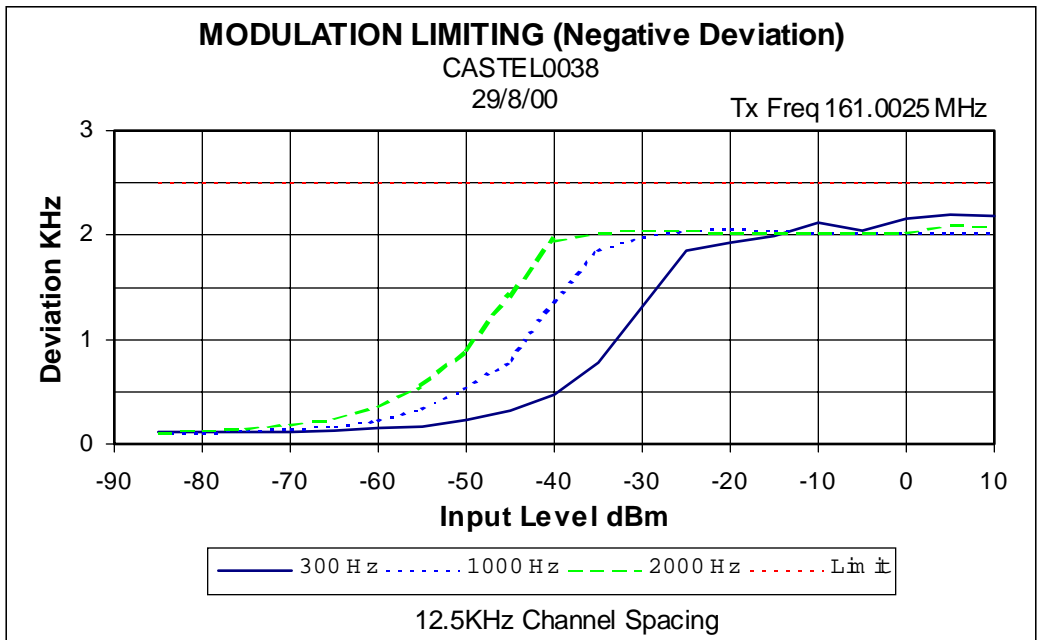
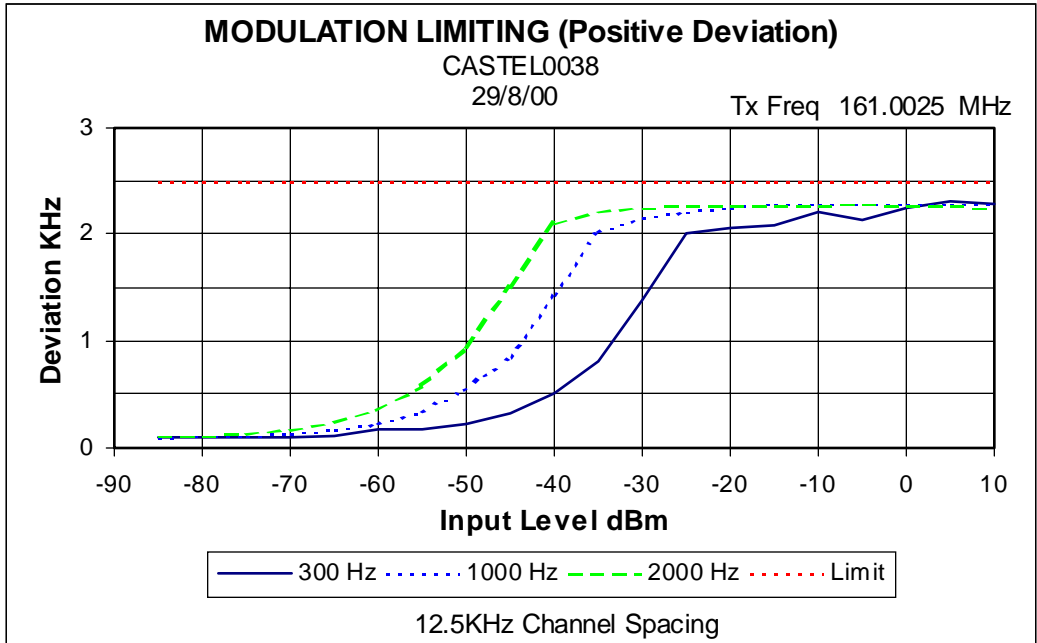

NAME OF TEST: TRANSMITTER MODULATION LIMITING
STEADY STATE AND INSTANTANEOUS

TEST CONDITIONS: Ambient Temperature 21°C
Relative Humidity 65%
Standard Voltage 120V AC

SPECIFICATION: FCC 47 CFR 2.1047 (b)

GUIDE: TIA/EIA-603 2.2.3

MEASUREMENT PROCEDURE:

1. The Equipment Under Test was set up as shown in the following diagram.
2. The modulation response was measured with a level stepped 20 dB above the level required to obtain 60% deviation at 1000Hz AF.
3. Measurements were made for both Positive and Negative deviation.

MEASUREMENT RESULTS: See the plots on the following page.

LIMIT CLAUSE: FCC 47 CFR 90.211 (a)

TEST SETUP: See page 28 for Test Equipment information.

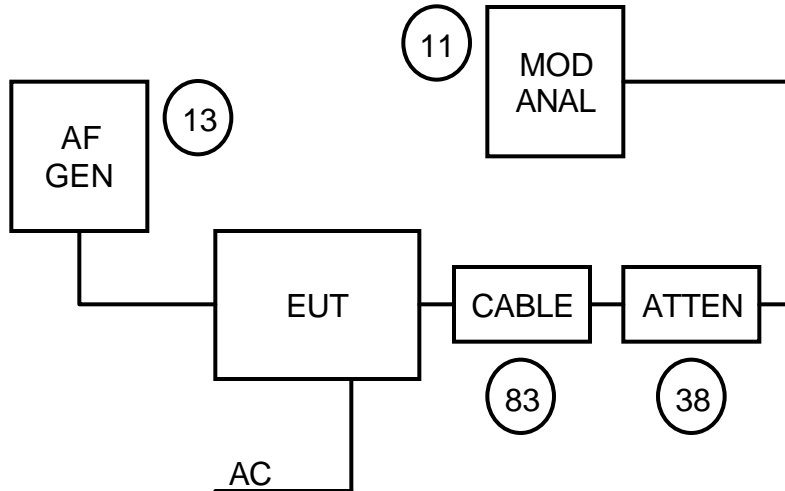

NAME OF TEST: TRANSMITTER MODULATION LIMITING
STEADY STATE AND INSTANTANEOUS

SPECIFICATION: FCC CFR 2.1047 (b)

Tx FREQUENCY: 161.0025 MHz

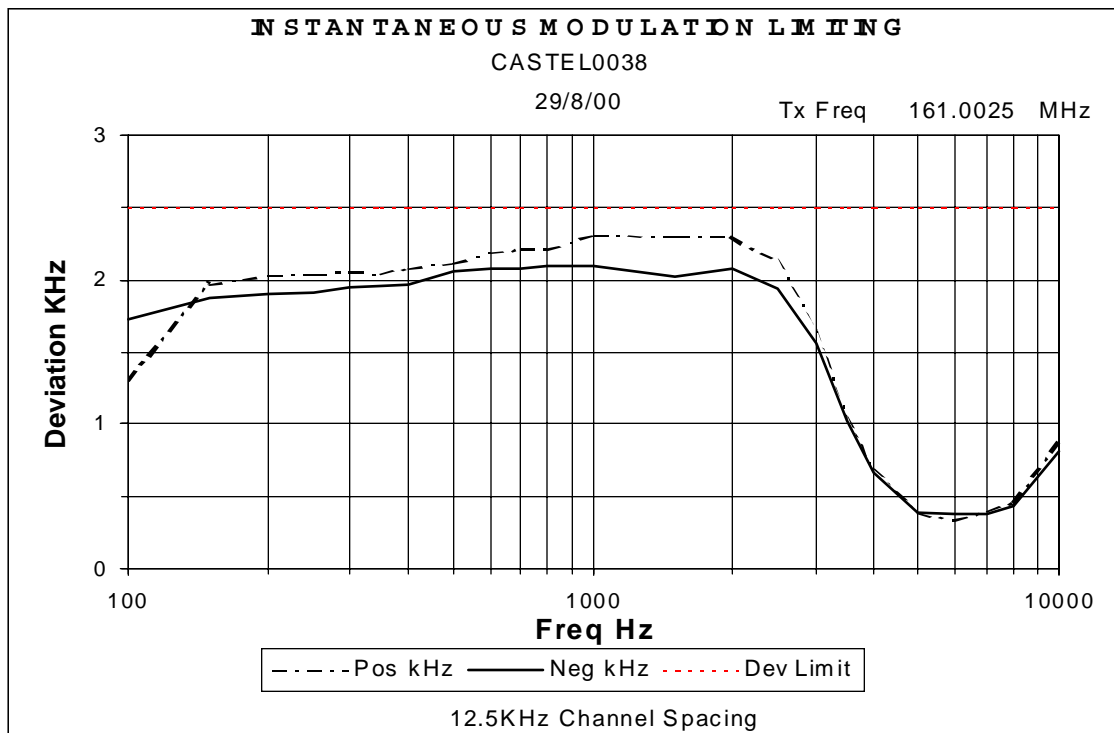
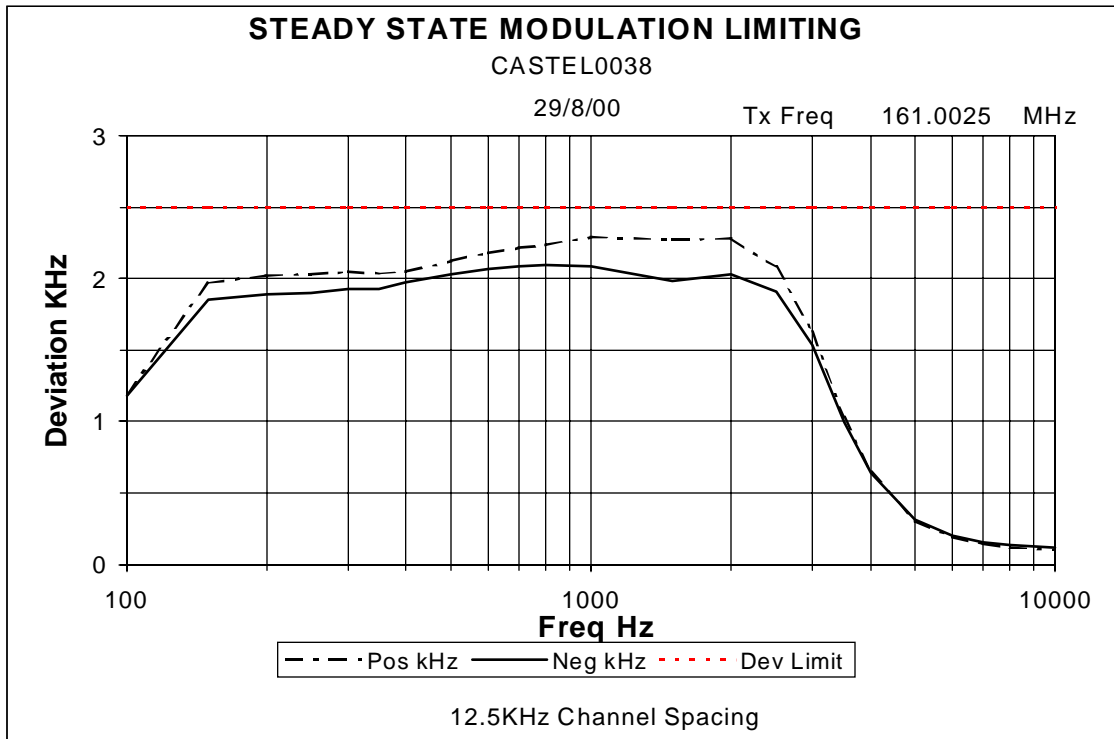

NAME OF TEST: OCCUPIED BANDWIDTH

TEST CONDITIONS: Ambient Temperature 17°C
 Relative Humidity 65%
 Standard Voltage 120V AC

SPECIFICATION: FCC 47 CFR 2.1049 (c)

GUIDE: TIA/EIA-603 2.2.11

MEASUREMENT PROCEDURE:

1. The Equipment Under Test was set up as shown in the following diagram.
2. The EUT was modulated by a 2500Hz tone at an input level 16dB above a level that produced 50% deviation. The input level was established at the frequency of maximum response of the audio modulating circuit.
3. The Occupied Bandwidth was measured on the Spectrum Analyser with the controls set as shown on the following plots.

MEASUREMENT RESULTS: See the plots on the following page.

LIMIT CLAUSE: FCC 47 CFR 90.210

TEST SETUP: See page 28 for Test Equipment information.

Emission Mask D 12.5kHz Channel Spacing

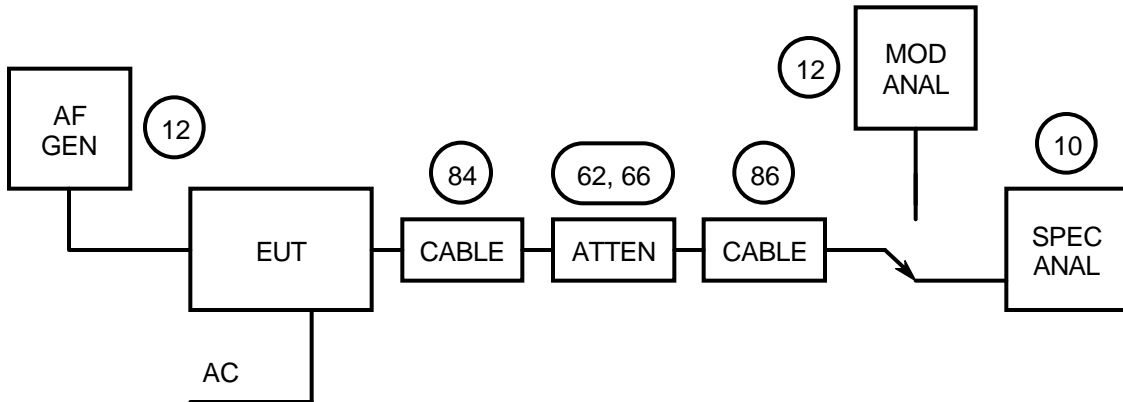

NAME OF TEST: OCCUPIED BANDWIDTH
SPECIFICATION: FCC CFR 2.1049 (c)
Tx FREQUENCY: 161.0025 MHz

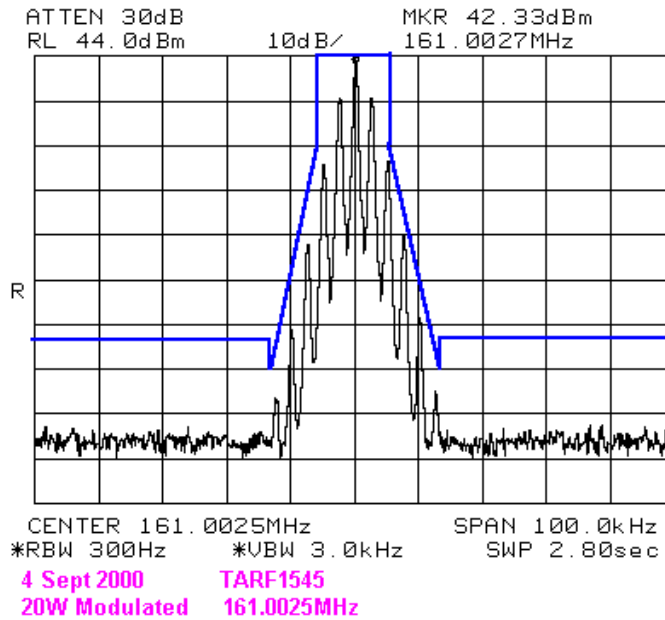
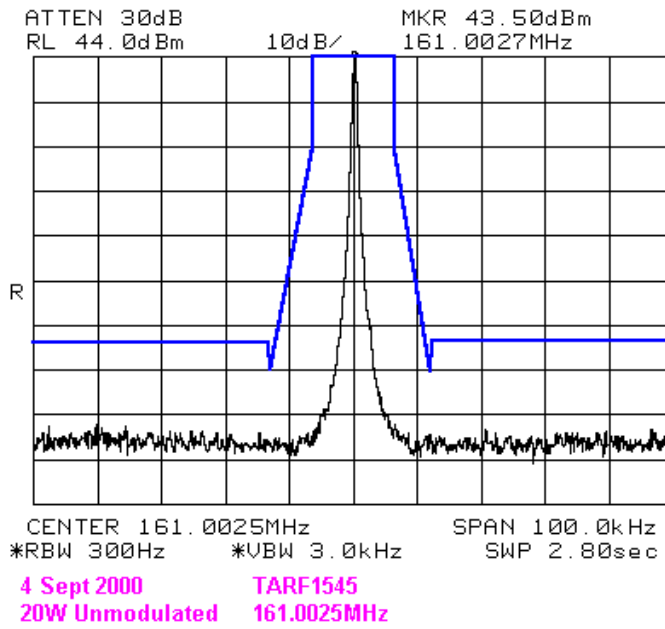

NAME OF TEST: SPURIOUS EMISSIONS (CONDUCTED)

TEST CONDITIONS: Ambient Temperature 21°C
 Relative Humidity 50%
 Standard Voltage 120V AC

SPECIFICATION: FCC 47 CFR 2.1051

GUIDE: TIA/EIA-603 2.2.13

MEASUREMENT PROCEDURE:

1. The Equipment Under Test was set up as shown in the following diagram.
2. The frequency range examined was from the lowest frequency generated within the EUT, to a frequency higher than the 10th Harmonic: 100kHz to Fc-BW
 Fc+BW to 2GHz
3. Spurious emissions which were attenuated more than 20dB below the limit were not recorded.

MEASUREMENT RESULTS: See the tables on the following page.

LIMIT CLAUSE: FCC 47 CFR 90.210

TEST SETUP: See page 28 for Test Equipment information.

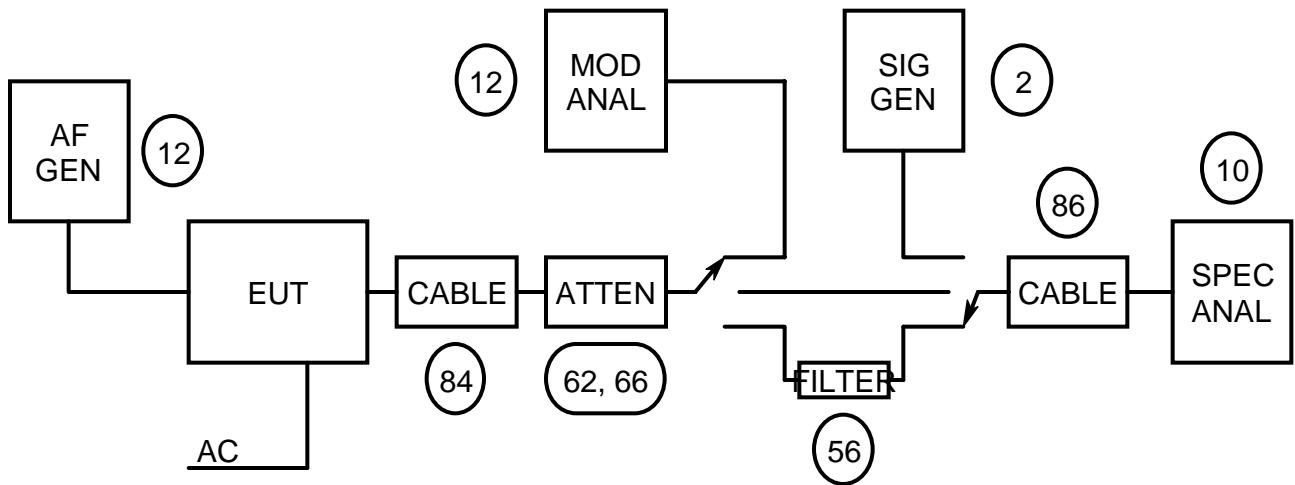

NAME OF TEST: SPURIOUS EMISSIONS (RADIATED)

TEST CONDITIONS: Ambient Temperature 19°C
 Relative Humidity 45%
 Standard Voltage 120V AC

SPECIFICATION: FCC 47 CFR 2.1053

GUIDE: TIA/EIA-603 2.2.12

MEASUREMENT PROCEDURE:

1. The Equipment Under Test was set up as shown in the following diagram.
2. The EUT was placed on a wooden turntable at a distance of three metres from the test antenna. The output terminal was connected to an RF dummy load.
3. The turntable was rotated through 360° to obtain the maximum response of each spurious emission. Valid emissions were determined by switching the EUT on and off.
4. The EUT was replaced by a signal generator and substitution antenna to make measurements by the substitution method.

MEASUREMENT RESULTS: See the tables on the following pages.

LIMIT CLAUSE: FCC 47 CFR 90.210

TEST SETUP: See page 28 for Test Equipment information.

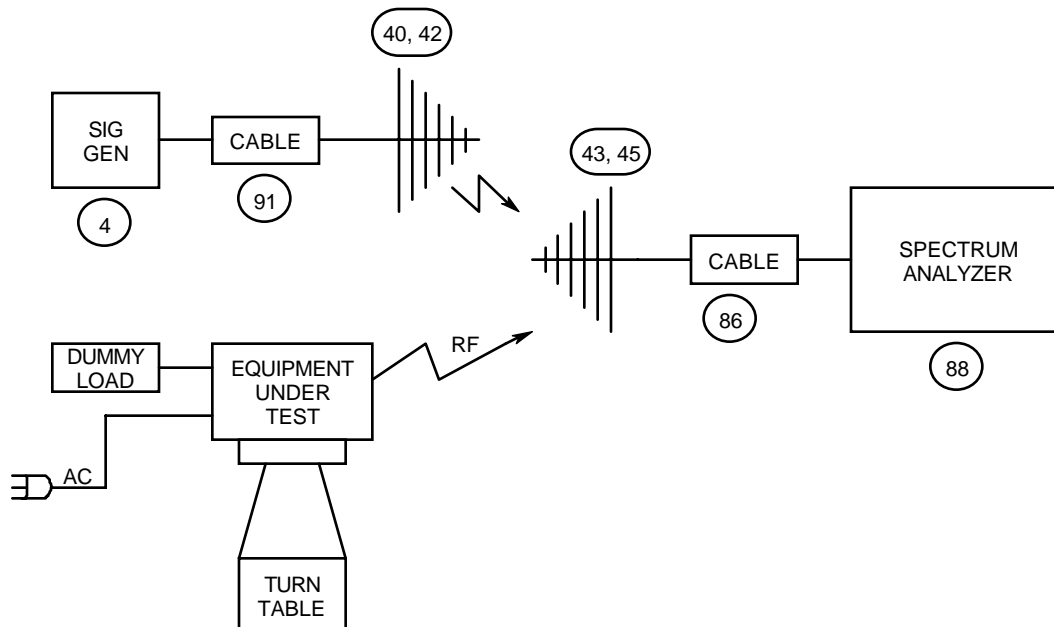

NAME OF TEST: SPURIOUS EMISSIONS (RADIATED)

SPECIFICATION: FCC CFR 2.1053

Tx FREQUENCY: 161.0025 MHz

12.5 kHz Channel Spacing	161.0025 MHz @ 100 W	Emission Mask D
Emission Frequency (MHz)	Level (dBm)	Level (dBc)
~	~	~
No emissions were detected at a level greater than 20 dB below the limit.		

LIMITS:

Carrier Output Power Watts	Emission Mask D 12.5 kHz Channel Spacing $50 + \text{Log}_{10}(P_{\text{Watts}})$	
100 W	-20 dBm	70 dBc
20 W	-20 dBm	63 dBc

NAME OF TEST: SPURIOUS EMISSIONS (RADIATED)

SPECIFICATION: FCC CFR 2.1053

Tx FREQUENCY: 161.0025 MHz

12.5 kHz Channel Spacing	161.0025 MHz @ 20 W	Emission Mask D
Emission Frequency (MHz)	Level (dBm)	Level (dBc)
~	~	~
No emissions were detected at a level greater than 20 dB below the limit.		

LIMITS:

Carrier Output Power Watts	Emission Mask D 12.5 kHz Channel Spacing $50 + \text{Log}_{10}(P_{\text{Watts}})$	
100 W	-20 dBm	70 dBc
20 W	-20 dBm	63 dBc

NAME OF TEST: TRANSMITTER FREQUENCY STABILITY (TEMPERATURE)

TEST CONDITIONS: Ambient Temperature 19°C
 Relative Humidity 45%
 Standard Voltage 120V AC

SPECIFICATION: FCC 47 CFR 2.1055 (a) (1)

GUIDE: TIA/EIA-603 2.2.2

MEASUREMENT PROCEDURE:

1. The Equipment Under Test was set up as shown in the following diagram.
2. The EUT was tested for frequency error from -30 °C to +50°C in 10 °C increments
3. The frequency error was recorded in parts per million (ppm).

MEASUREMENT RESULTS: See the plot on the following page.

LIMIT CLAUSE: FCC 47 CFR 90.213

TEST SETUP: See page 28 for Test Equipment information.

Frequency Range: 150 MHz to 174 MHz

Channel Spacing (kHz)	Frequency Error (ppm)
12.5	2.5

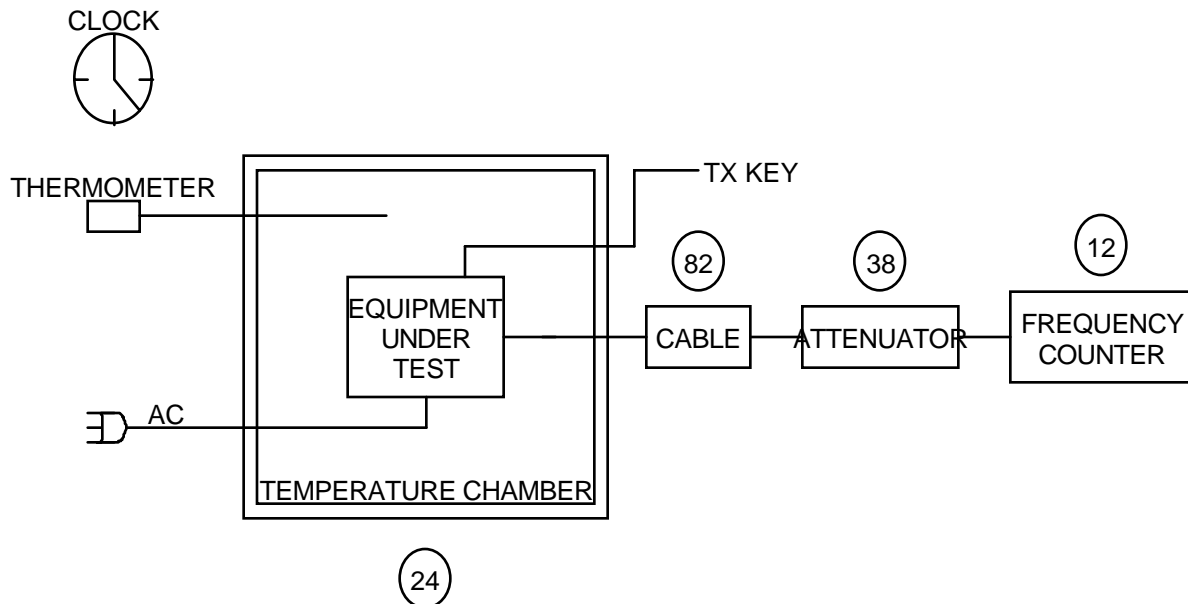

NAME OF TEST: TRANSMITTER FREQUENCY STABILITY (TEMPERATURE)
SPECIFICATION: FCC 47 CFR 2.1055 (a) (1)
Tx FREQUENCY: 161.0025 MHz

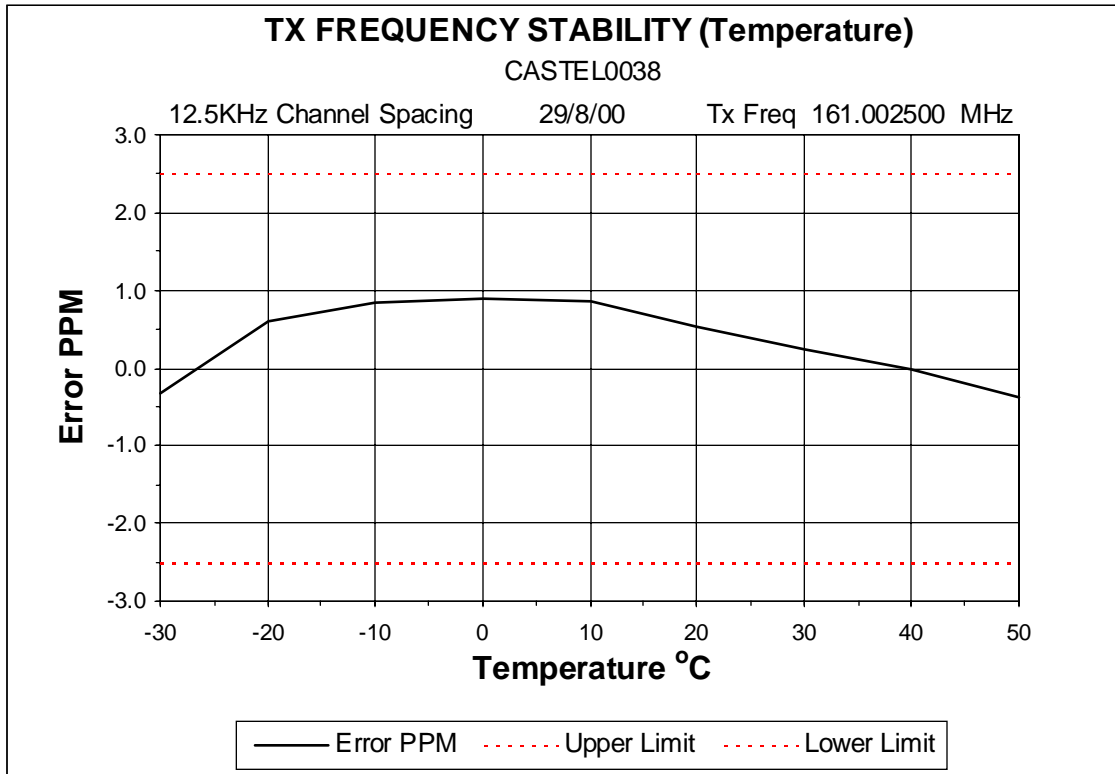

NAME OF TEST: TRANSMITTER FREQUENCY STABILITY (VOLTAGE)

TEST CONDITIONS: Ambient Temperature 19°C
 Relative Humidity 45%
 Standard Voltage 120V AC

SPECIFICATION: FCC 47 CFR 2.1055 (d) (1)

GUIDE: TIA/EIA-603 2.2.2

MEASUREMENT PROCEDURE:

1. The Equipment Under Test was set up as shown in the following diagram.
2. The EUT was tested for frequency error at an input voltage to the power supply of 85% to 115% using a Variac.
3. The frequency error was recorded in parts per million (ppm).

TEST SETUP: See page 28 for Test Equipment information.

MEASUREMENT RESULTS:

Frequency Range: 150 MHz to 174 MHz

Channel Spacing (kHz)	FREQUENCY ERROR (ppm) @ 161.0025 MHz		
	102V AC	120V AC	138V AC
12.5	0.60	0.61	0.56

LIMIT CLAUSE: FCC 47 CFR 90.213

Channel Spacing (kHz)	Frequency Error (ppm)
12.5	2.5

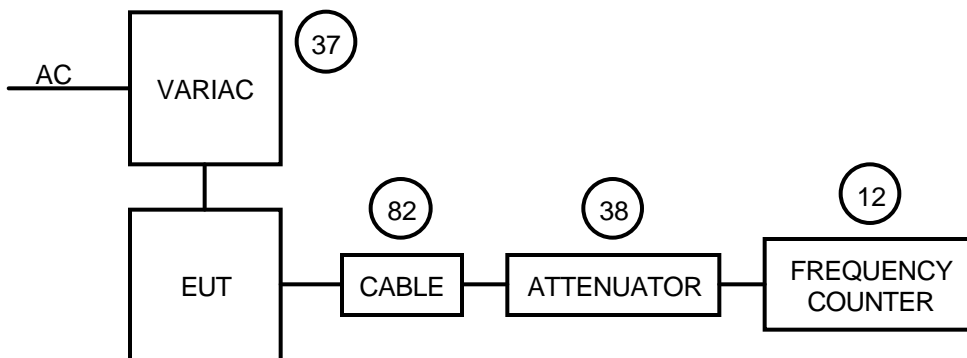

NAME OF TEST: TRANSIENT FREQUENCY BEHAVIOUR

TEST CONDITIONS: Ambient Temperature 20°C
 Relative Humidity 60%
 Standard Voltage 120V AC

SPECIFICATION: FCC 47 CFR 90.214

GUIDE: TIA/EIA-603 2.2.19

MEASUREMENT PROCEDURE:

1. The Equipment Under Test was set up as shown in the following diagram.
2. Measurements and plots were made following the TIA/EIA procedure.

MEASUREMENT RESULTS: See the tables and plots on the following pages

LIMIT CLAUSE: FCC 47 CFR 90.214

TEST SETUP: See page 28 for Test Equipment information.

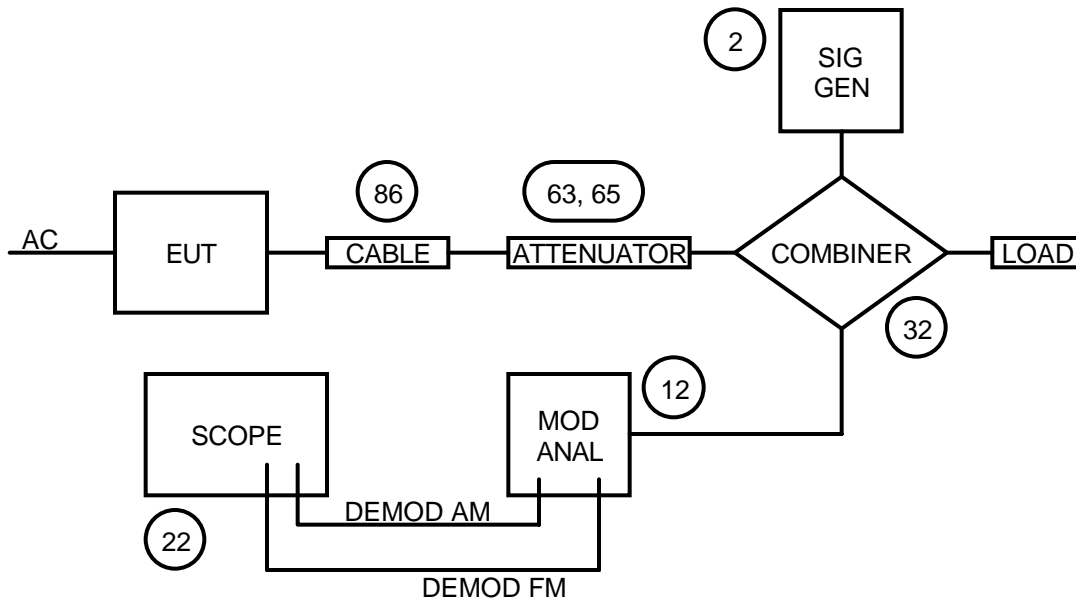

NAME OF TEST: TRANSIENT FREQUENCY BEHAVIOUR
 SPECIFICATION: FCC 47 CFR 90.214
 Tx FREQUENCY: 161.0025 MHz

FREQUENCY	161.0025 MHz @ 100 W Tx	
TRANSIENT RESPONSE PERIOD	CARRIER PEAK VARIATION FROM NORMAL	
	Key ON (kHz)	Key OFF (kHz)
t1	2.26	N/A
t2	0.38	N/A
t3	N/A	0.25
t2 ~ t3	0.38	
ERROR LIMIT (t2 ~ t3) @ 2.5 ppm (kHz)	0.63	

Confirm that during periods t1 and t3 the frequency difference does not exceed the value of one channel separation.	YES	NO
	Y	
Confirm that during the period t2 the frequency difference does not exceed half a channel separation.	YES	NO
	Y	
Confirm that during the period t2 to t3 the frequency difference does not exceed the frequency error limit.	YES	NO
	Y	

LIMIT: 12.5 kHz CHANNEL SPACING

TRANSIENT PERIODS	MAXIMUM FREQUENCY DIFFERENCE (kHz)	FREQUENCY RANGE 150 – 174 MHz
t1 (mS)	± 12.5	5 mS
t2 (mS)	± 6.25	20 mS
t3 (mS)	± 12.5	5 mS

NAME OF TEST: TRANSIENT FREQUENCY BEHAVIOUR

SPECIFICATION: FCC 47 CFR 90.214

Tx FREQUENCY: 161.0025 MHz
12.5kHz Channel Spacing 100 W

Key ON

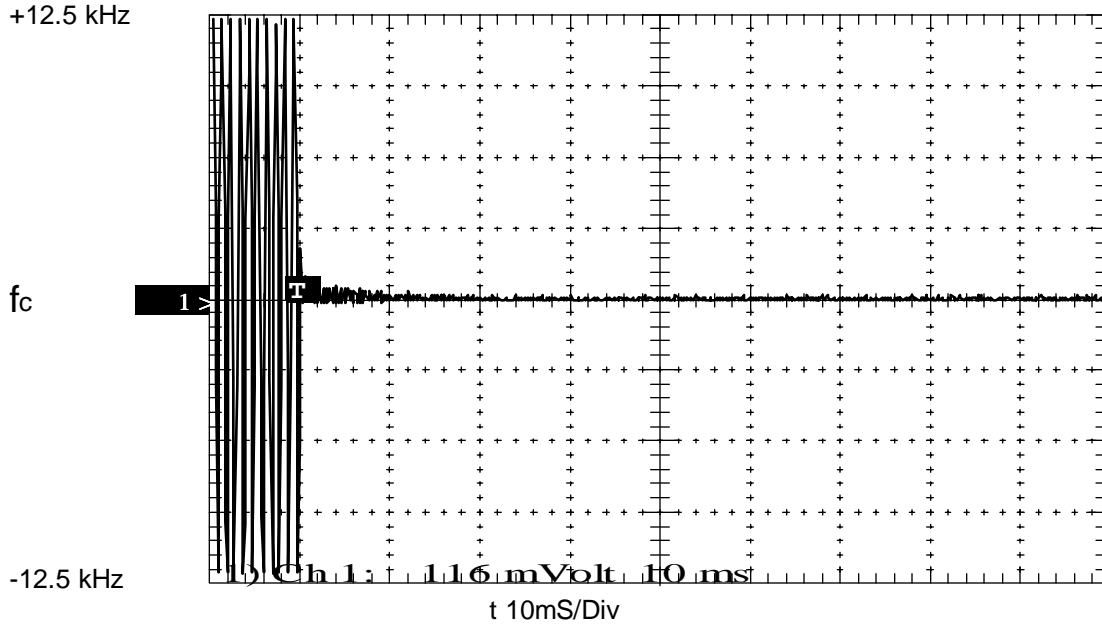

12.5kHz Channel Spacing 100 W

Key OFF

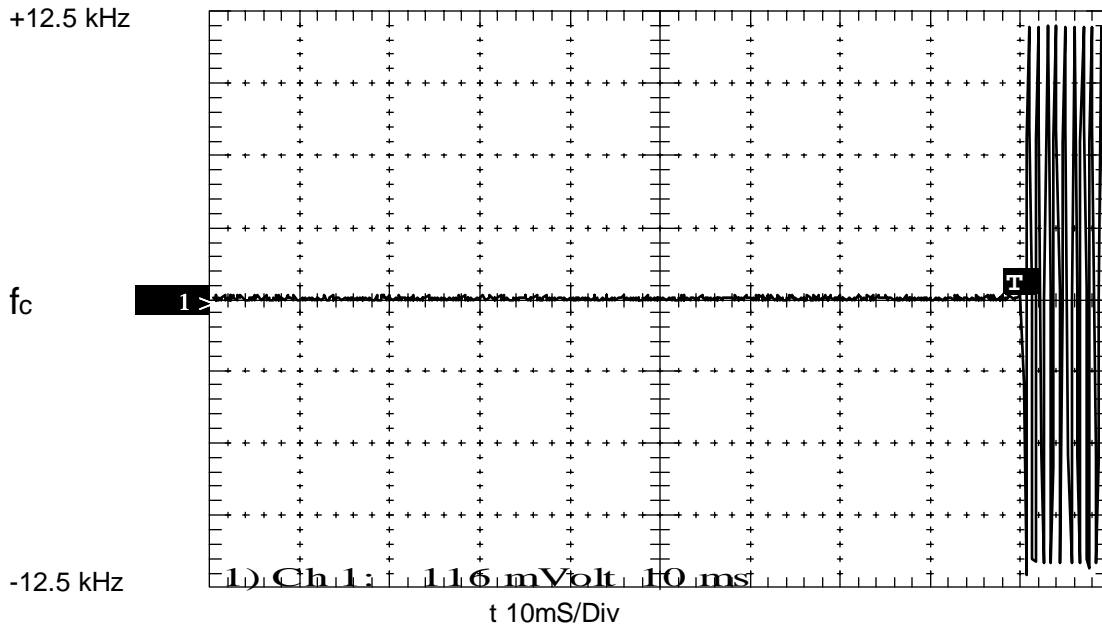

NAME OF TEST: TRANSIENT FREQUENCY BEHAVIOUR
 SPECIFICATION: FCC 47 CFR 90.214
 Tx FREQUENCY: 161.0025 MHz

FREQUENCY	161.0025 MHz @ 20 W Tx	
TRANSIENT RESPONSE PERIOD	CARRIER PEAK VARIATION FROM NORMAL	
	Key ON (kHz)	Key OFF (kHz)
t1	1.58	N/A
t2	0.13	N/A
t3	N/A	0.74
t2 ~ t3	0.13	
ERROR LIMIT (t2 ~ t3) @ 2.5 ppm (kHz)	0.63	

Confirm that during periods t1 and t3 the frequency difference does not exceed the value of one channel separation.	YES	NO
	Y	
Confirm that during the period t2 the frequency difference does not exceed half a channel separation.	YES	NO
	Y	
Confirm that during the period t2 to t3 the frequency difference does not exceed the frequency error limit.	YES	NO
	Y	

LIMIT: 12.5 kHz CHANNEL SPACING

TRANSIENT PERIODS	MAXIMUM FREQUENCY DIFFERENCE (kHz)	FREQUENCY RANGE 150 – 174 MHz
t1 (mS)	± 12.5	5 mS
t2 (mS)	± 6.25	20 mS
t3 (mS)	± 12.5	5 mS

NAME OF TEST: TRANSIENT FREQUENCY BEHAVIOUR

SPECIFICATION: FCC 47 CFR 90.214

Tx FREQUENCY: 161.0025 MHz
12.5kHz Channel Spacing 20 W

Key ON

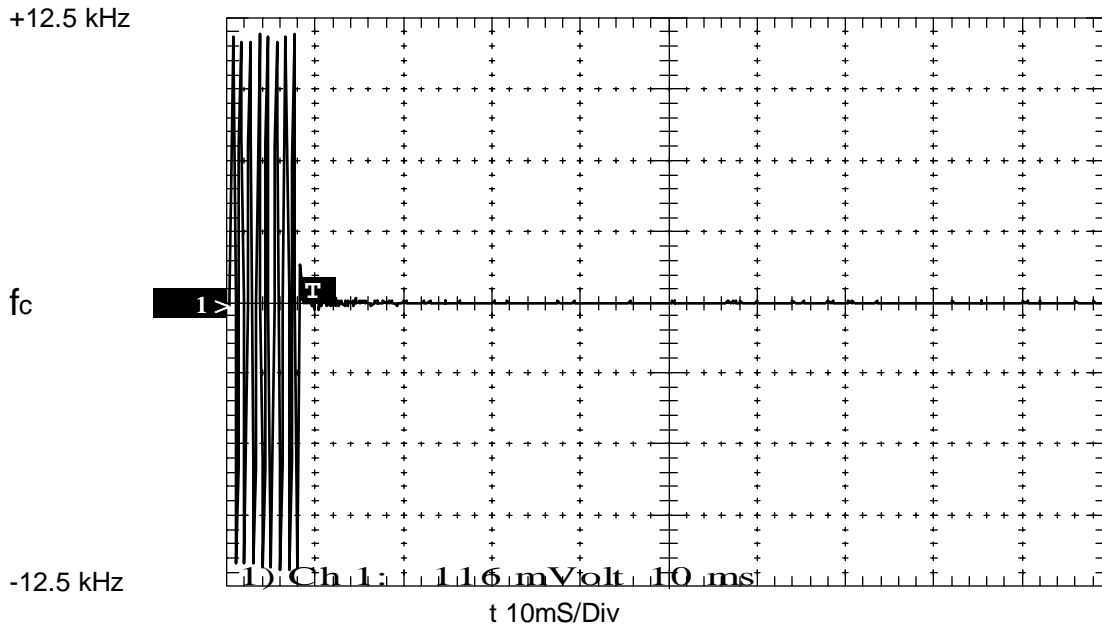

12.5kHz Channel Spacing 20 W

Key OFF

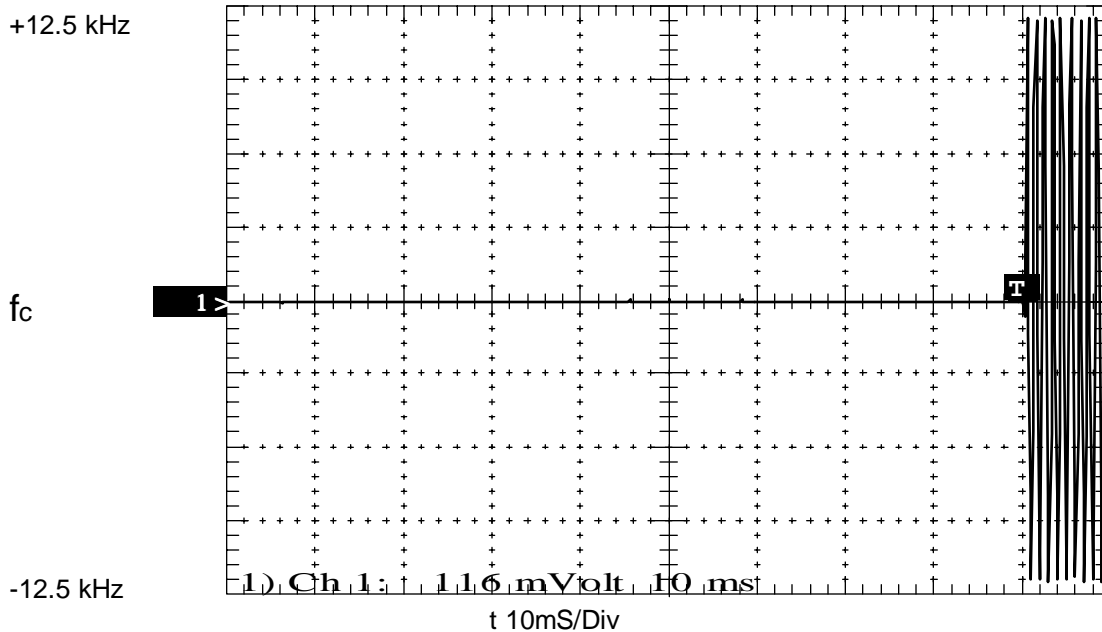

TEST EQUIPMENT LIST

To facilitate inclusion on each page, the test equipment used is identified (numbered) and listed against the related test in the report.

No	Equipment Type	Model number	Serial Number	Tait ID:
01	Signal Generator	HP 8642B (Opt 001)	2512A00176	E3064
02	Signal Generator	HP8648A	3430U00344	E3579
03	Signal Generator	HP8656A	2142A02103	E3063
04	Signal Generator	HP8648C	3443U00543	E3558
05	Signal Generator	SMY01 1062.5502.11	841736/019	E3553
10	Spectrum Analyser	HP8596E (Opt 140)	3346A00213	E3427
11	Modulation Analyser	HP8901B (Opt 002)	2441A00393	E3073
12	Modulation Analyser	FMA 0852.8500.52	842541/001	E3554
13	Audio Analyser	HP8903A	2308A02597	E3074
14	Power Head	HP11722A	2320A00688	E3307
15	Power Meter	NRVS 1020.1809.02	841954/005	E3555
16	Power Sensor	URV5-Z4 395.1619.55	841.498/003	E3557
20	Power Supply	HP6032A	2441A-0041	E3075
21	Power Supply	NGSM32/10 192.0810.31	Fnr 434	E3556
22	Oscilloscope	Tektronics TDS 340	B013611	E3585
23	Universal Counter	Goldstar FC-2015U	600801	E3550
24	Environmental Chamber	Contherm Spatial Cal	E3397	E3397
24	Environmental Chamber	Contherm Temp Control	E3397	E3397
25	Portable Hygrometer (ACL)	Rotronic A1	2070300/38	N/A
25	Whirling Hygrometer	Casella 3156 / 82	TA004	TA004
30	Directional Coupler	HP778D-012	1144 07392	E3292
31	4 Port Combiner (CAST)	DVU4, W 201.4018.03	300729/47	E3623
32	4 Port Combiner	DVU4, W 201.4018.03	300971/28	E3572
33	3 Port Combiner	Weinschel 1506A, 1W	LD858	E3672
34	Mixer Spurious Emission	Tait (3.2G ≤ Rfx ≤ 4.0G)	E3661	E3661
35	Mixer Transient ACP	Minicircuits ZAD-11	77031	E3394

TEST EQUIPMENT LIST (Cont.)

No	Equipment Type	Model number	Serial Number	Tait ID:
36	Voltmeter	HP3478A	2545A25838	E1559
37	Variac	Yamabishi S-260-5	TX-533	E1737
38	RX and TX, RF Paths	Tait CAST Interface	E3067	E3067
40	Reference Dipoles	Emco 3121C-DB1	9510-1164	E3559
41	Antenna	Biconical	9307-1680	E3033
42	Reference Horn Antenna	Emco DRG 3115	9512-4638	E3560
43	Horn Antenna	Emco DRG 3115	2084	E3076
44	Corner 175-420 MHz	Ailtech DM 105A-T2	J1417-103	E3031
45	Corner 400-1000 MHz	Ailtech DM 105A-T3	J1418-108	E3036
46	S-LINE TEM CELL	1089.9296.02	338232/003	E3636
50	Amplifier AR 1M-1000M	25W1000A	20444	E3637
51	Amplifier AR 10K-250M	25A250	16373	E3570
52	Amplifier +21.7 dB	Tait ZFL-1000LN	E3660	E3360
53	RF Filter 21.4M (CAST)	Tait NDK 21G-6DT	E3069	E3069
54	RF Filter 21.4M (ACP)	Tait NDK 21G-6DT	RA-7'	E3249
55	Filter Notch	Tait	N/A	?
56	Filter High Pass	Tait	Mhz	?
57	Filter Low Pass	Tait	Mhz	?
60	RF Attenuator 250W	Weinschel 45-30-34	JW663	E3386
61	RF Attenuator 150W	Weinschel 40-20-33	CJ404	E3387
62	RF Attenuator 150W	Weinschel 57-10-34	LB590	E3674
63	RF Attenuator 150W	Weinschel 40-06-34	KV457	E3561
64	RF Attenuator 50W	Weinschel 24-10-34	AL0401	E3388
65	RF Attenuator 50W	Weinschel 24-20-44	AW1266	E3562

TEST EQUIPMENT LIST (Cont.)

No	Equipment Type	Model number	Serial Number	Tait ID:
66	RF Attenuator 25W	Weinschel 33-20-33	BD5871	E3673
67	RF Attenuator 150W(CAST)	Weinschel 40-20-33	CJ405	3366/82
70	RF Load 150W	Byrd 8166	524	E3625
71	RF Load 50 W	Weinschel F1426	BF0487	E3675
72	RF Load 50 W	Weinschel F1426	AE2490	E3624
73	RF Termination 20W	Deltec	118.001	E3626
74	RF Termination W	MCL NTRM-50	951215	E3574
75	RF Termination W	MCL NTRM-50	954214	E3575
76	RF Termination W	MCL NTRM-50	954214	E3576
80	20 M Coax Cable	RG214/U 50 (Ext Cal)	CBL01	E3659
81	2 M Coax Cable	RG213/U 50 (Ext Cal)	CBL02	E3658
82	3 M Coax Cable (BLUE)	Suhner Sucoflex 104A	25033 / 4A	E3694
83	1 M Coax Cable (BLUE)	Suhner Sucoflex 104A	25006 / 4A	E3693
84	1 M Coax Cable (BLUE)	Suhner Sucoflex 104A	25005 / 4A	E3692
85	1 M Coax Cable (BLUE)	Suhner Sucoflex 104A	25004 / 4A	E3691
86	1 M Coax Cable (BLUE)	Suhner Sucoflex 104A	25003 / 4A	E3690
87	Audio Analyser	HP8903B	2818A04275	E3710
88	Spectrum Analyser	HP8562E	3821A00799	E3715
89	Field Strength Meter	Holaday HI-422	95661	E3630
90	Power Supply	HP6012B	2524A00616	E3712
91	20 M Coax Cable	RG214/U 50 (Ext Cal)	3404	24/08/99
92	LISN	EMCO 3825/2	9204-1961	E3040