

TEST REPORT

REPORT NUMBER 1438

July 99

RADIO PERFORMANCE MEASUREMENTS

On the T858-20-0500 Base Station Transmitter

FCC ID: CASTEL0030

SN° 224012

in accordance with

FCC 47 CFR Parts 22 and 90

PREPARED BY:

Rob Weeks

Test Technician

CHECKED & APPROVED BY:

S.A. Crompton

Laboratory Manager

TELTEST Laboratories

Tait Electronics Limited

PO Box 1645

558 Wairakei Road

Christchurch 5

New Zealand

Phone: +64 3 358 3399

Fax: +64 3 358 0432

TABLE OF CONTENTS

TEST	PAGE
TRANSMITTER OUTPUT POWER (CONDUCTED)	3
AUDIO FREQUENCY FILTER	4
TRANSMITTER AUDIO FREQUENCY RESPONSE	6
MODULATION LIMITING	8
MODULATION LIMITING (STEADY STATE)	11
MODULATION LIMITING (INSTANTANEOUS)	13
OCCUPIED BANDWIDTH	15
SPURIOUS EMISSIONS (CONDUCTED)	18
SPURIOUS EMISSIONS (RADIATED)	23
TRANSMITTER FREQUENCY STABILITY (TEMPERATURE)	28
TRANSMITTER FREQUENCY STABILITY (VOLTAGE)	30
TRANSIENT FREQUENCY BEHAVIOUR	31
LIST OF TEST EQUIPMENT	40

NAME OF TEST: TRANSMITTER OUTPUT POWER (CONDUCTED)

TEST CONDITIONS: Ambient temperature 19.5°C
 Relative humidity 55 %
 Standard Voltage 120VAC

SPECIFICATION: FCC 47 CFR 2.985 (a)

GUIDE: TIA/EIA-603 2.2.1

MEASUREMENT PROCEDURE:

1. The Equipment Under Test (EUT) was set up as shown on the following diagram.
2. The coaxial attenuator used has an impedance of 50Ω.
3. The unmodulated output power was measured by means of an RF Power meter.

MEASUREMENT RESULTS:

Manufacturers rated output power: Continuously variable 10W to 50W

460.1MHz	50W nominal	10W nominal
Watts	48.11	10.16
% Variation from nom	-3.8	1.6
Measurement uncertainty (dB)	+0.63 -0.68	

LIMIT CLAUSE: FCC 47 CFR 90.205

Radio Type: Base Station
 Frequency Band: 440MHz - 480MHz

(n) The output power shall not exceed by more than 20% the manufacturers rated output power for the particular transmitter.

TEST SETUP: See page 40 for test equipment information.

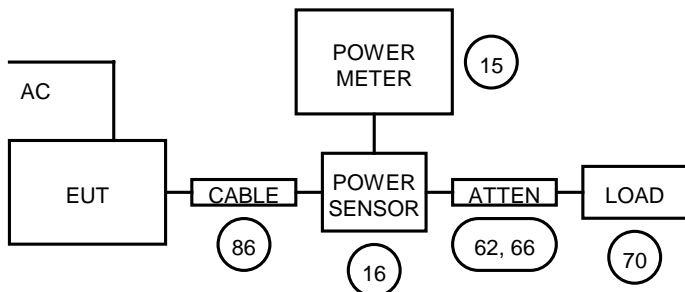

NAME OF TEST: AUDIO FREQUENCY FILTER RESPONSE

TEST CONDITIONS: Ambient temperature 15.5°C
Relative humidity 55 %
Standard Voltage 120VAC

SPECIFICATION: FCC 47 CFR 2.987(a)

GUIDE: TIA/EIA-603 2.2.15

MEASUREMENT PROCEDURE:

1. The Equipment Under Test (EUT) was set up as shown on the following diagram.
2. The EUT was set up in such a way that the audio input and audio output were connected directly to the audio low pass filter circuitry.
3. A tone of 1000 Hz was set as a reference.
4. The AF applied to the filter was varied, with the level held constant. The filter response in dB was plotted.

MEASUREMENT RESULTS:

See the plot on following page.

LIMIT CLAUSE: FCC 47 CFR 90.211(a)

TEST SETUP USED: See page 40 for test equipment information.

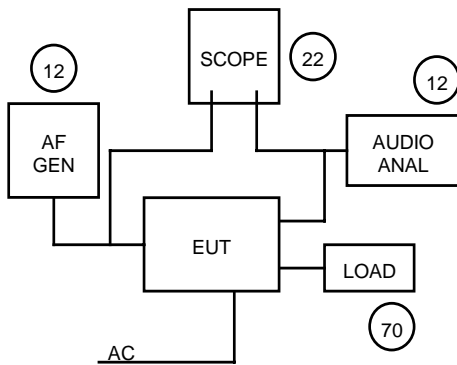

FCC ID: CASTEL0030

NAME OF TEST: AUDIO FREQUENCY FILTER RESPONSE

SPECIFICATION: FCC 47 CFR 2.987(a)

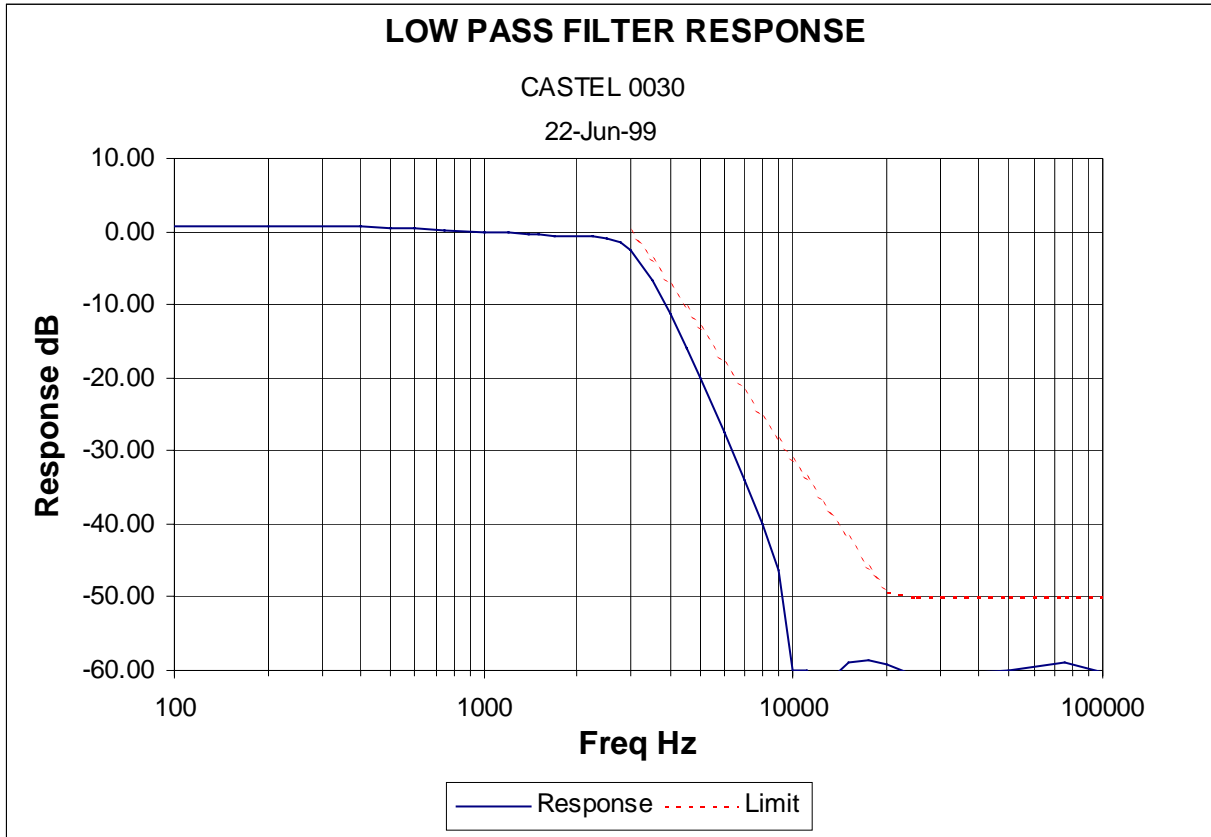

NAME OF TEST: TRANSMITTER AUDIO FREQUENCY RESPONSE
PRE-EMPHASIS

TEST CONDITIONS: Ambient temperature 17°C
Relative humidity 50 %
Standard Voltage 120VAC

SPECIFICATION: FCC 47 CFR 2.987 (a)

GUIDE: TIA/EIA-603 2.2.6

MEASUREMENT PROCEDURE:

1. The Equipment Under Test (EUT) was set up as shown on the following diagram.
2. An audio input tone of 1000Hz was applied, the level set to obtain 20% max deviation. This was used as the 0dB reference point.
3. With the input level held constant, the AF frequency was varied.
4. The response in dB relative to 1000Hz was measured.

MEASUREMENT RESULTS:

See the plots on following page for both 12.5KHz and 25KHz channel separation.

LIMIT CLAUSE: TIA/EIA-603 4.2.6

TEST SETUP: See page 40 for test equipment information.

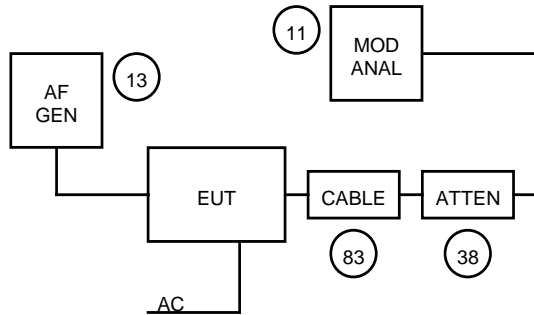

NAME OF TEST: TRANSMITTER AUDIO FREQUENCY RESPONSE
PRE-EMPHASIS

SPECIFICATION: FCC 47 CFR 2.987 (a)

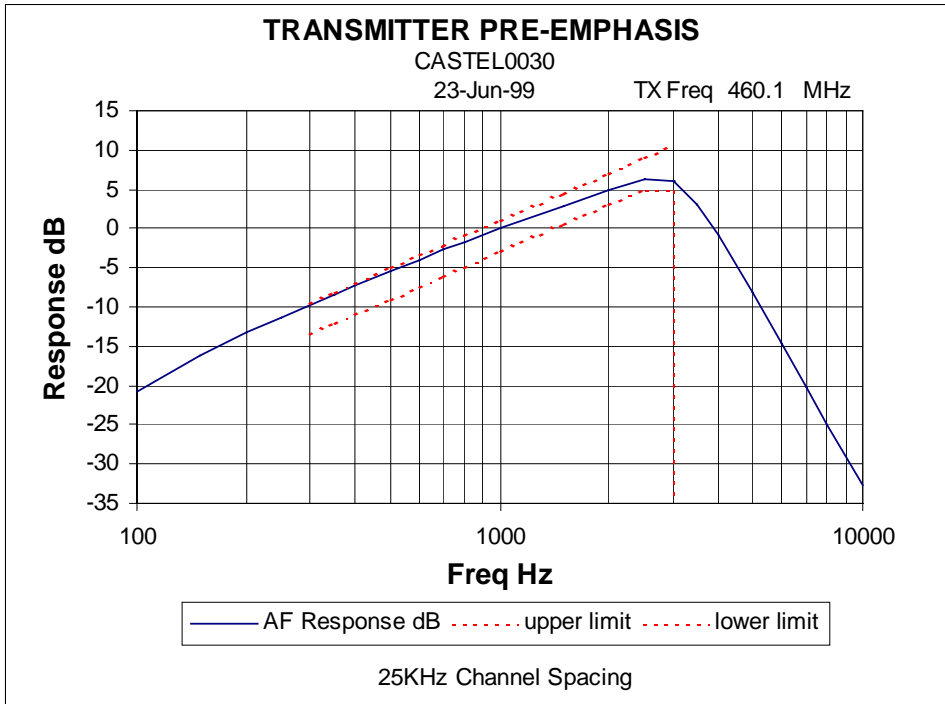
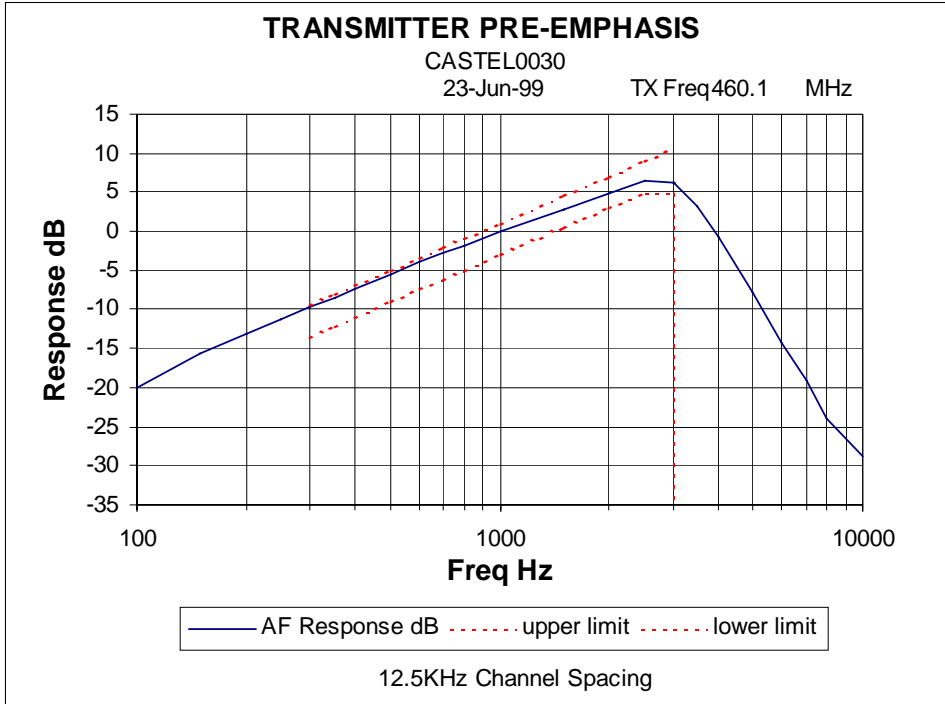

NAME OF TEST: TRANSMITTER MODULATION LIMITING

TEST CONDITIONS: Ambient temperature 17°C
Relative humidity 50 %
Standard Voltage 120VAC

SPECIFICATION: FCC 47 CFR 2.987

GUIDE: TIA/EIA-603 2.2.3

MEASUREMENT PROCEDURE:

1. The Equipment Under Test (EUT) was set up as shown on the following diagram.
2. The modulation response was measured at three audio frequencies, varying the input level.
3. Measurements were made for both positive and negative deviation.

MEASUREMENT RESULTS:

See the plots on following pages for both 12.5KHz and 25KHz channel spacing.

LIMIT CLAUSE: FCC 47 CFR 90.211(a)

TEST SETUP: See page 40 for test equipment information.

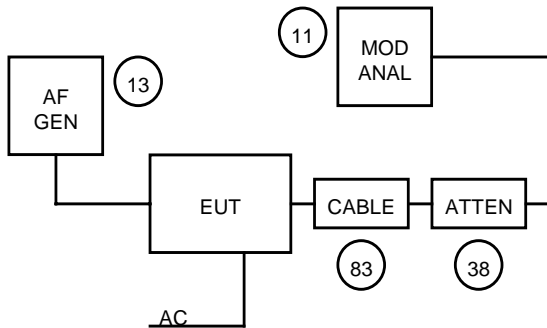

NAME OF TEST: TRANSMITTER MODULATION LIMITING

SPECIFICATION: FCC 47 CFR 2.987

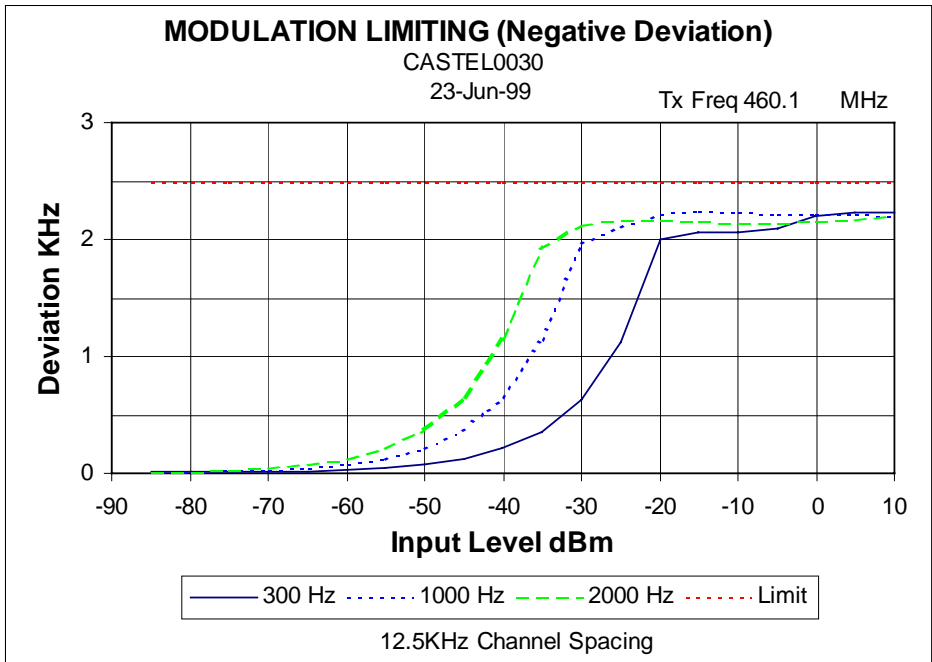
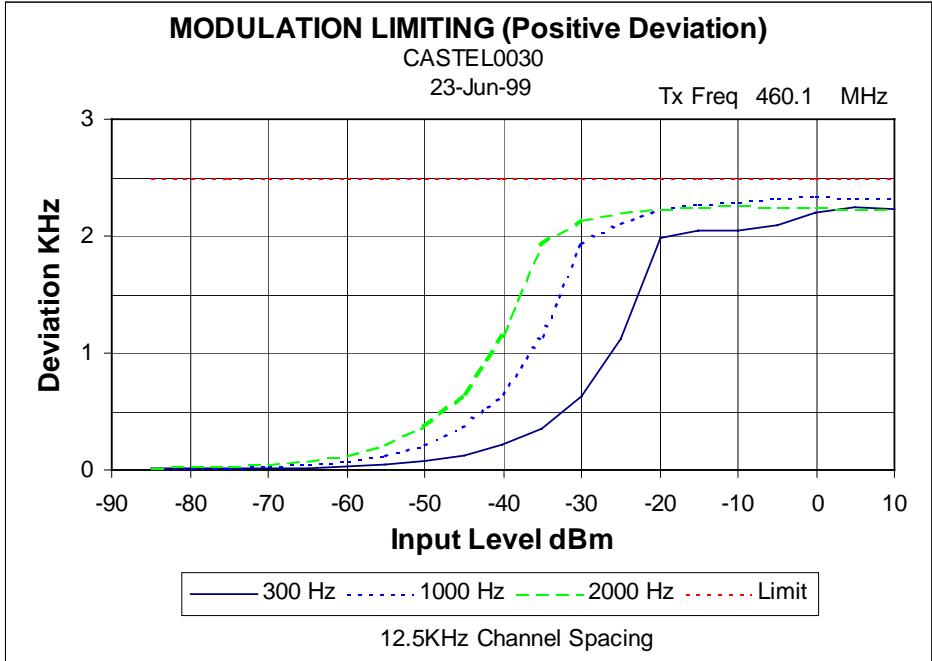

NAME OF TEST: TRANSMITTER MODULATION LIMITING

SPECIFICATION: FCC 47 CFR 2.987

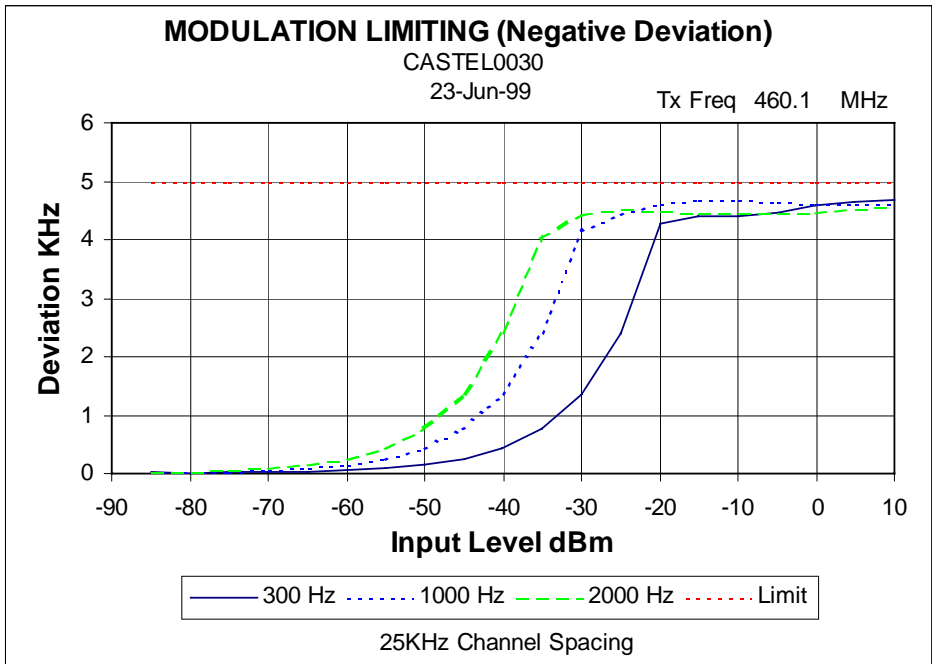
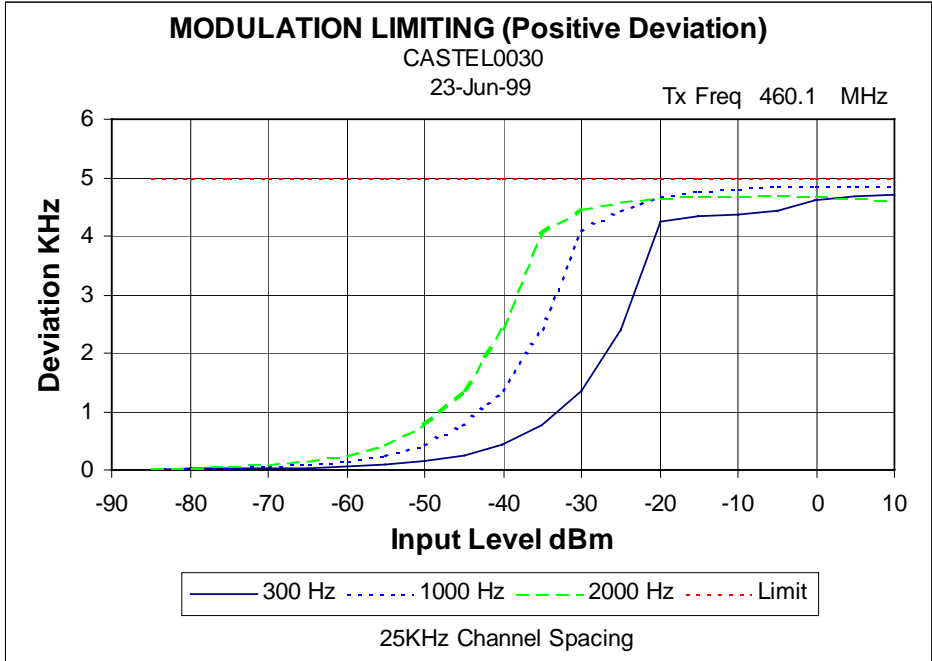

NAME OF TEST: TRANSMITTER MODULATION LIMITING
STEADY STATE

TEST CONDITIONS: Ambient temperature 17°C
Relative humidity 50 %
Standard Voltage 120VAC

SPECIFICATION: FCC 47 CFR 2.987 (b)

GUIDE: TIA/EIA-603 2.2.3

MEASUREMENT PROCEDURE:

1. The Equipment Under Test (EUT) was set up as shown on the following diagram.
2. The modulation response was measured with the level stepped 20dB above the level required to obtain 60% Deviation at 1000Hz AF.
3. Measurements were made for both positive and negative deviation.

MEASUREMENT RESULTS:

See the plots on following page for both 12.5KHz and 25KHz channel spacing.

LIMIT CLAUSE: FCC 47 CFR 90.211(a)

TEST SETUP: See page 40 for test equipment information.

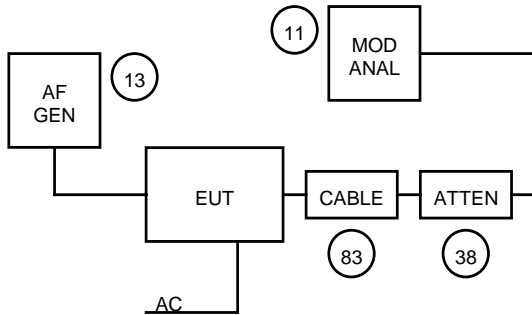

NAME OF TEST: TRANSMITTER MODULATION LIMITING
STEADY STATE

SPECIFICATION: FCC 47 CFR 2.987 (b)

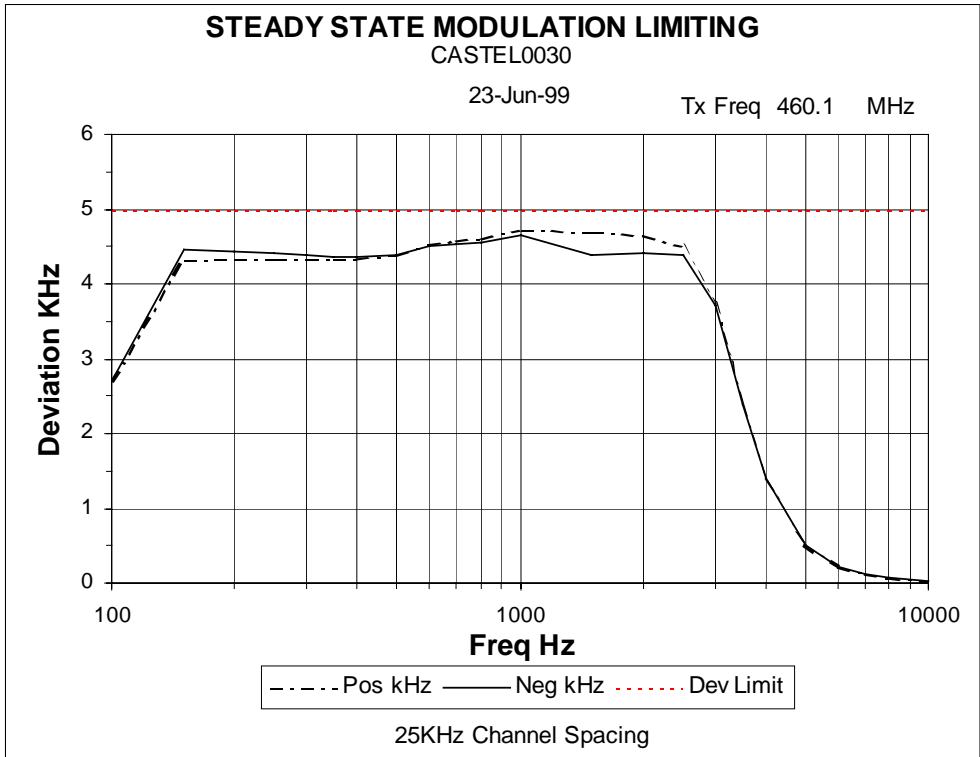
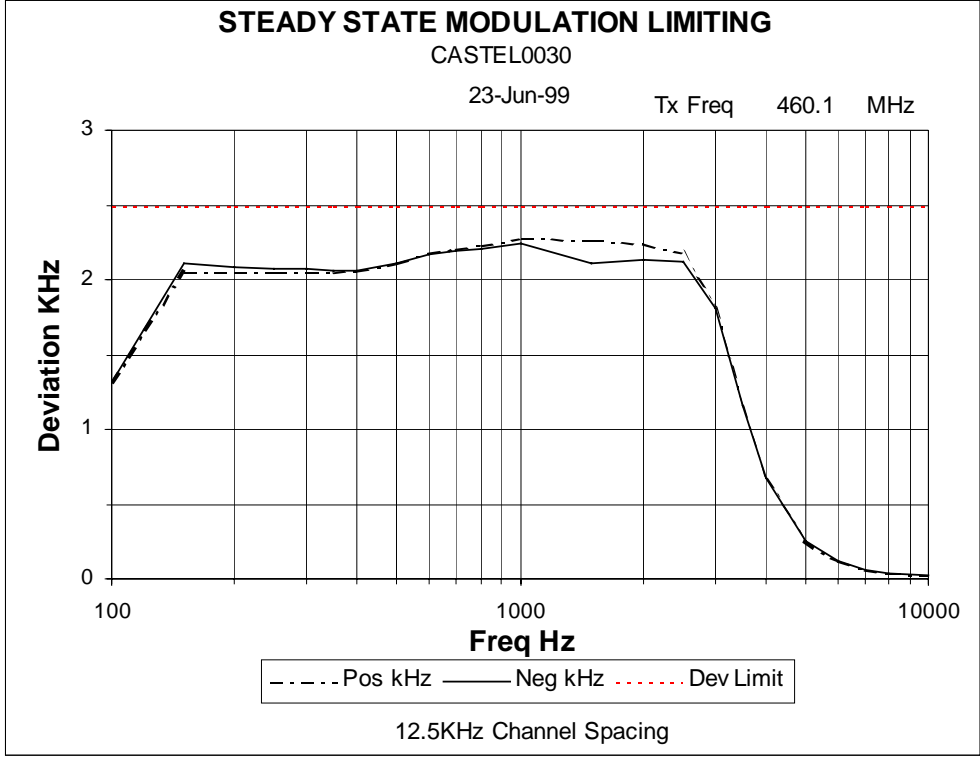

NAME OF TEST: TRANSMITTER MODULATION LIMITING INSTANTANEOUS

TEST CONDITIONS: Ambient temperature 17°C
Relative humidity 50 %
Standard Voltage 120VAC

SPECIFICATION: FCC 47 CFR 2.987 (b)

GUIDE: TIA/EIA-603 2.2.3

MEASUREMENT PROCEDURE:

1. The Equipment Under Test (EUT) was set up as shown on the following diagram.
2. The modulation response was measured with the level stepped 20dB above the level required to obtain 60% Deviation at 1000Hz AF.
3. Measurements were made for both positive and negative deviation.

MEASUREMENT RESULTS:

See the plots on following page for both 12.5KHz and 25KHz channel spacing.

LIMIT CLAUSE: FCC 47 CFR 90.211(a)

TEST SETUP: See page 40 for test equipment information.

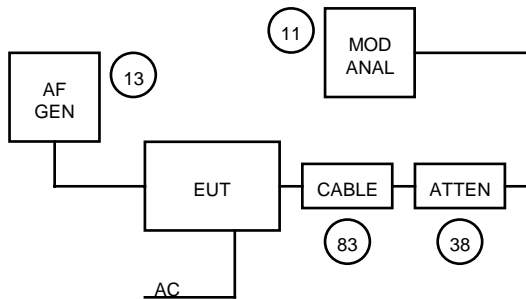

NAME OF TEST: TRANSMITTER MODULATION LIMITING INSTANTANEOUS

SPECIFICATION: FCC 47 CFR 2.987 (b)

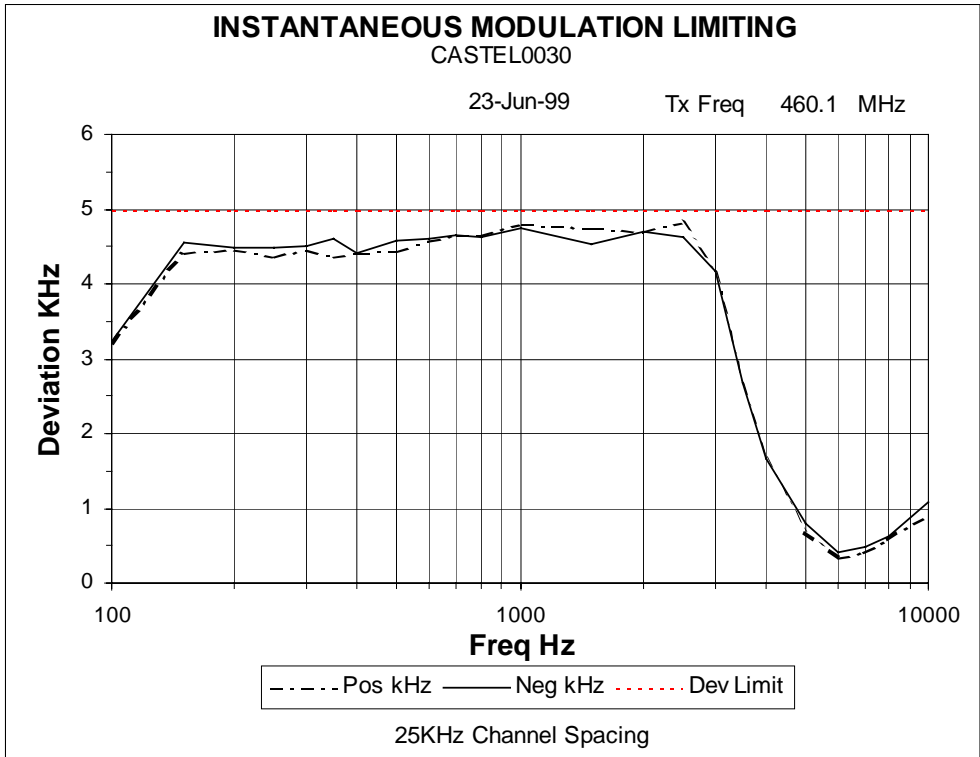
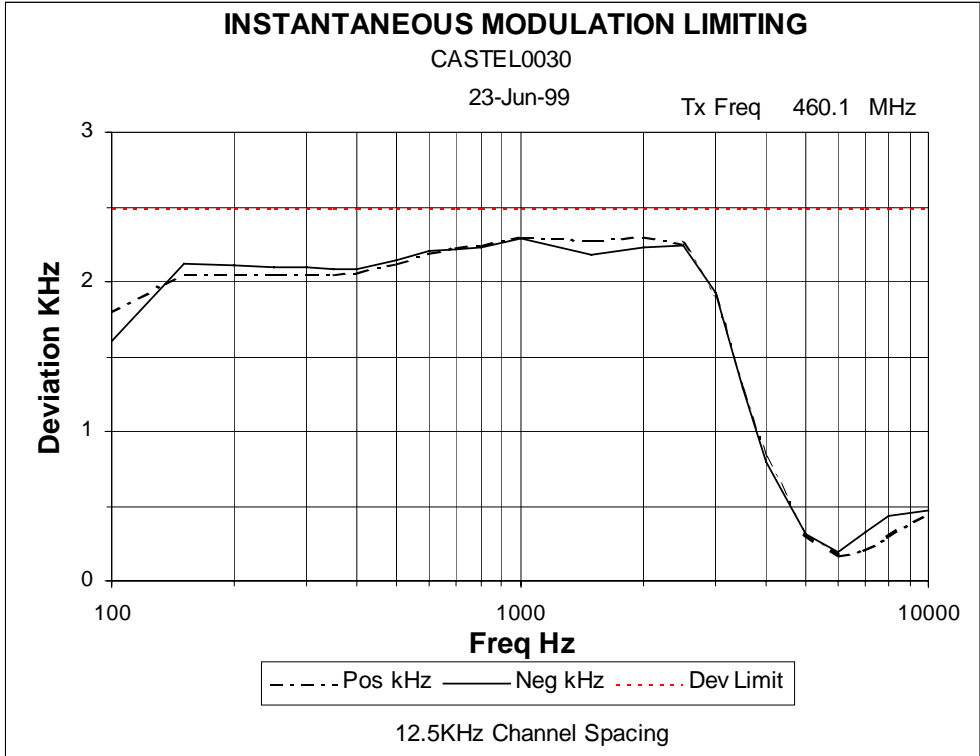

NAME OF TEST: OCCUPIED BANDWIDTH

TEST CONDITIONS: Ambient temperature 18°C
Relative humidity 55 %
Standard Voltage 120VAC

SPECIFICATION: FCC 47 CFR 2.989(c)

GUIDE: TIA/EIA-603 Para 2.2.11

MEASUREMENT PROCEDURE:

1. The Equipment Under Test (EUT) was set up as shown on the following diagram.
2. The EUT was modulated by a 2500Hz tone at an input level 16dB above a level that produced 50% deviation.
3. The Occupied Bandwidth was measured on the Spectrum Analyser with the controls set as shown on the following plots.

MEASUREMENT RESULTS:

See the plots on following pages for both 12.5KHz and 25KHz channel spacing.

LIMIT CLAUSE: FCC 47 CFR 90.210

Emission Mask AB≅ 25KHz channel spacing
Emission Mask AD≅ 12.5KHz channel spacing

TEST SETUP: See page 40 for test equipment information.

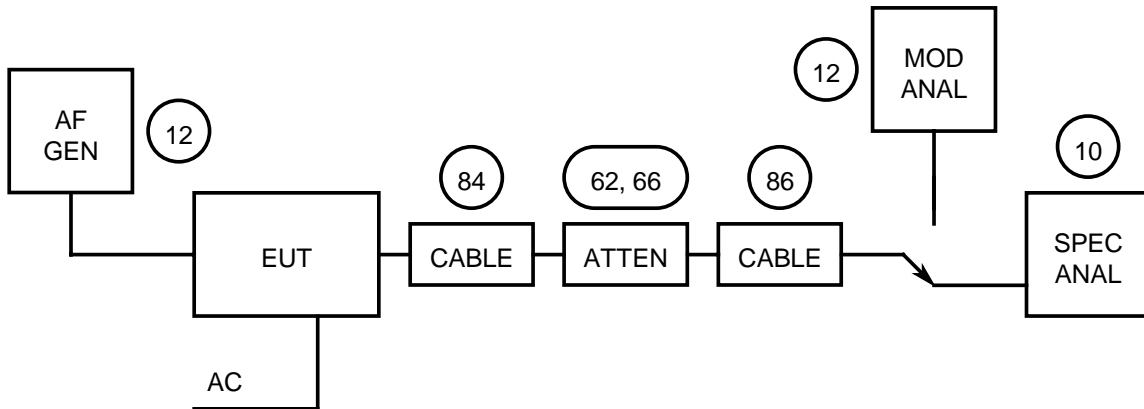

NAME OF TEST: OCCUPIED BANDWIDTH

SPECIFICATION: FCC 47 CFR 2.989(c)

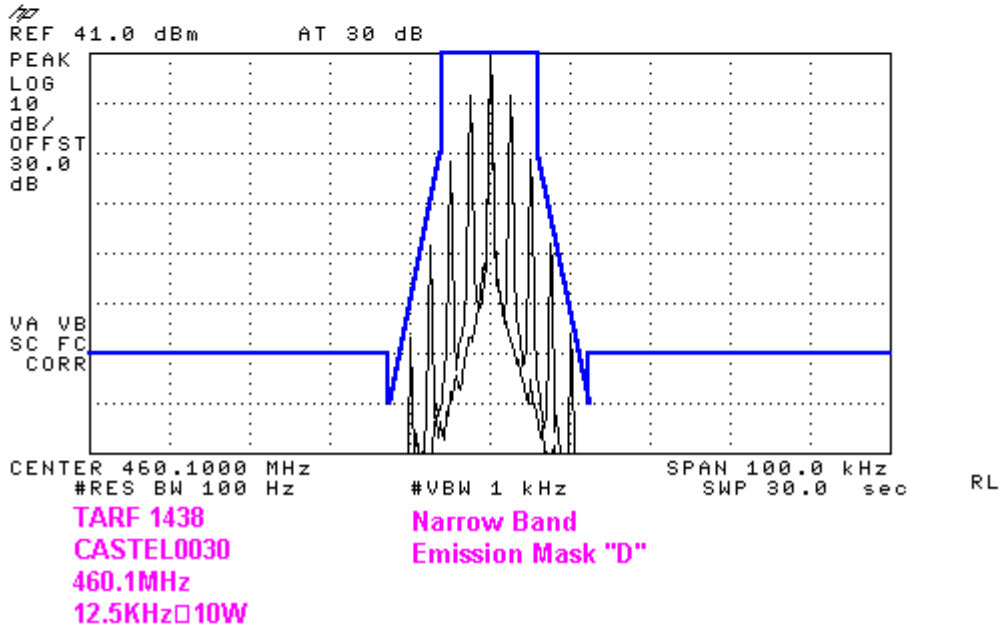
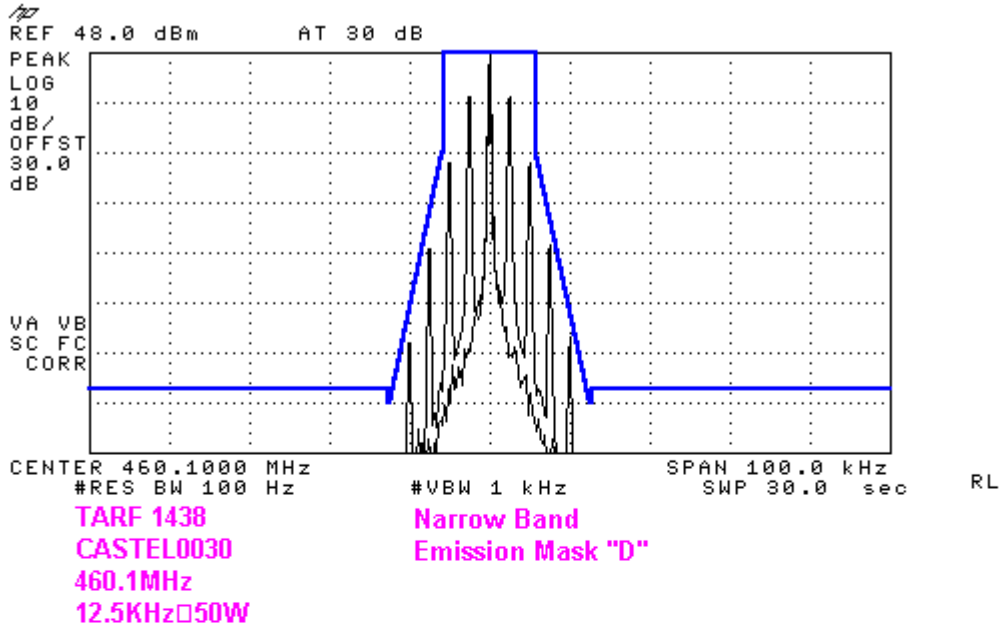

NAME OF TEST: OCCUPIED BANDWIDTH

SPECIFICATION: FCC 47 CFR 2.989(c)

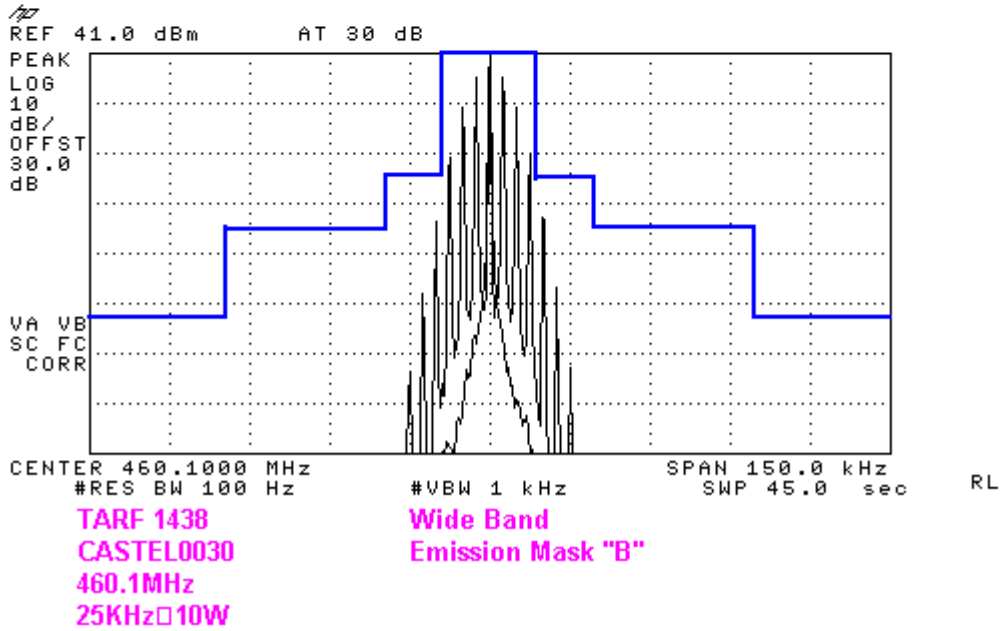
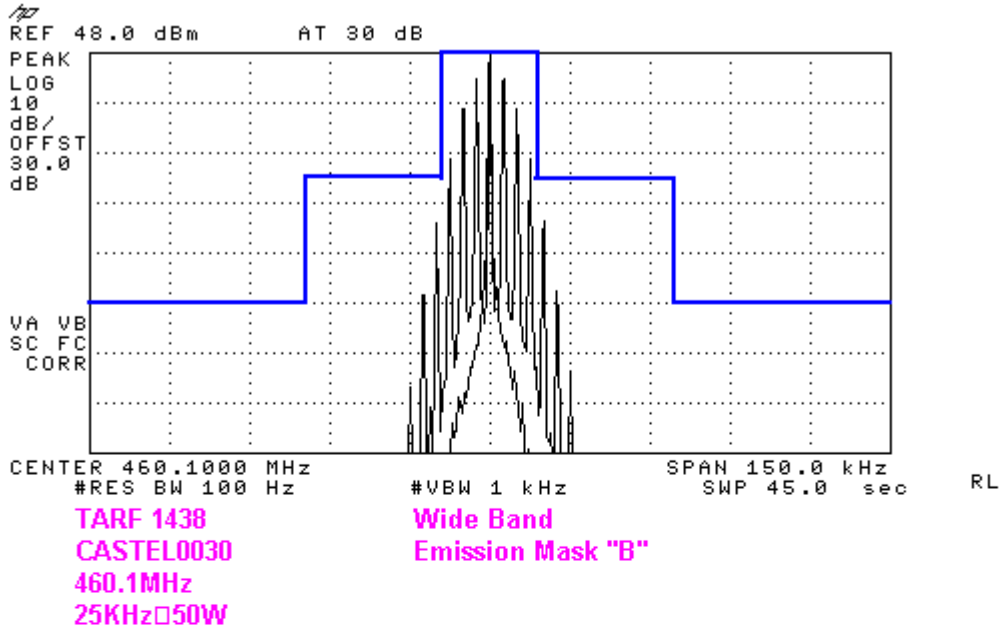

NAME OF TEST: SPURIOUS EMISSIONS (CONDUCTED)

TEST CONDITIONS: Ambient temperature 18°C
Relative humidity 55 %
Standard Voltage 120VAC

SPECIFICATION: FCC 47 CFR 2.991

GUIDE: TIA/EIA-603 2.2.13

MEASUREMENT PROCEDURE:

1. The Equipment Under Test (EUT) was set up as shown on the following diagram.
2. The frequency range examined was from the lowest frequency generated within the EUT to a frequency higher than the 10th harmonic: 100KHz to Fc-BW
Fc+BW to 5GHz
3. Spurious emissions which were attenuated more than 20dB below the limit were not recorded

MEASUREMENT RESULTS:

See the tables on following pages for both 12.5KHz and 25KHz channel spacing.

LIMIT CLAUSE: FCC 47 CFR 90.210

See the tables on following pages.

TEST SETUP: See page 40 for test equipment information.

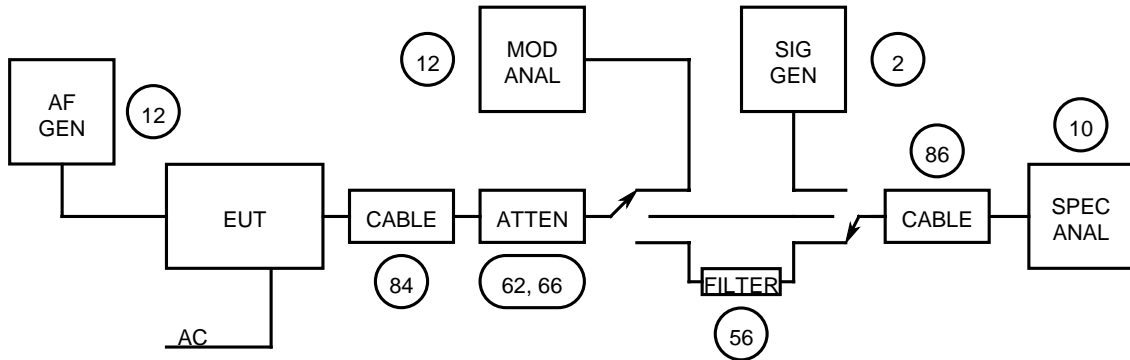

NAME OF TEST: SPURIOUS EMISSIONS (RADIATED)

TEST CONDITIONS: Ambient temperature 17°C
Relative humidity 55 %
Standard Voltage 120VAC

SPECIFICATION: FCC 47 CFR 2.993(a)

GUIDE: TIA/EIA-603 2.2.12

MEASUREMENT PROCEDURE:

1. The Equipment Under Test (EUT) was set up as shown on the following diagram.
2. The EUT was placed on a wooden turntable at a distance of three metres from the test antenna. The output terminal was connected to an RF dummy load.
3. The turntable was rotated through 360° to obtain the maximum response of each spurious emission. Valid emissions were determined by switching the EUT on and off.
4. The EUT was replaced by a signal generator and substitution antenna to make measurements by the substitution method.

MEASUREMENT RESULTS:

See the tables on following pages for 12.5KHz and 25KHz channel spacing.

LIMIT CLAUSE: FCC 47 CFR 90.210

See the tables on following pages

TEST SETUP: See page 40 for test equipment information.

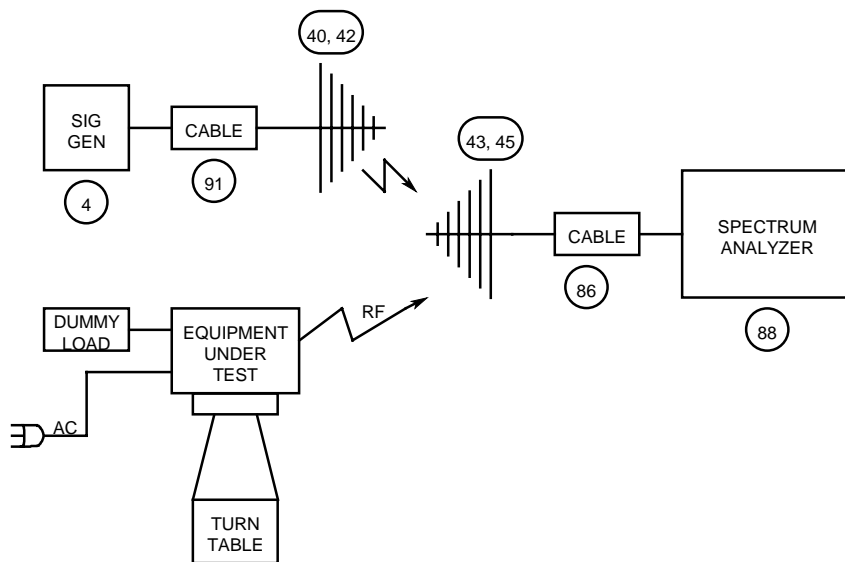

NAME OF TEST: SPURIOUS EMISSIONS (RADIATED)

SPECIFICATION: FCC 47 CFR 2.993(a)

12.5KHz channel spacing		460.1MHz @ 50W	Emission Mask AD \cong
Emission Freq MHz	Level dBm		Level dBc
1840.4	-36.5		83.5
No other emissions were detected at a level greater than 20 dB below the limit			

LIMITS:

Carrier output power P Watts	Emission Mask AD \cong 12.5KHz channel spacing $50+\text{Log}_{10}(P_{\text{Watts}})$	
	50W	67dBc
10W	60dBc	-20dBm

NAME OF TEST: SPURIOUS EMISSIONS (RADIATED)

SPECIFICATION: FCC 47 CFR 2.993(a)

12.5KHz channel spacing		460.1MHz @ 10W	Emission Mask AD \cong
Emission Freq MHz	Level dBm		Level dBc
1840.4	-37.5		77.5
No other emissions were detected at a level greater than 20 dB below the limit			

LIMITS:

Carrier output power P Watts	Emission Mask AD \cong 12.5KHz channel spacing $50 + \text{Log}_{10}(P_{\text{Watts}})$	
	50W	67dBc
10W	60dBc	-20dBm

NAME OF TEST: TRANSMITTER FREQUENCY STABILITY (TEMPERATURE)

TEST CONDITIONS: Ambient temperature 20°C
 Relative humidity 50 %
 Standard Voltage 120VAC

SPECIFICATION: FCC 47 CFR 2.995(a)(1)

GUIDE: TIA/EIA-603 2.2.2

MEASUREMENT PROCEDURE:

1. The Equipment Under Test (EUT) was set up as shown on the following diagram.
2. The EUT was tested for frequency error from -30°C to -50°C in 10°C increments.
3. The frequency error was recorded in parts per million (PPM)

MEASUREMENT RESULTS:

See the plot on the following page.

LIMIT CLAUSE: FCC 47 CFR 90.213

Frequency Range 421MHz to 512MHz

Channel Spacing (kHz)	Frequency Error (PPM)
12.5	1.5
25	2.5

TEST SETUP: See page 40 for test equipment information.

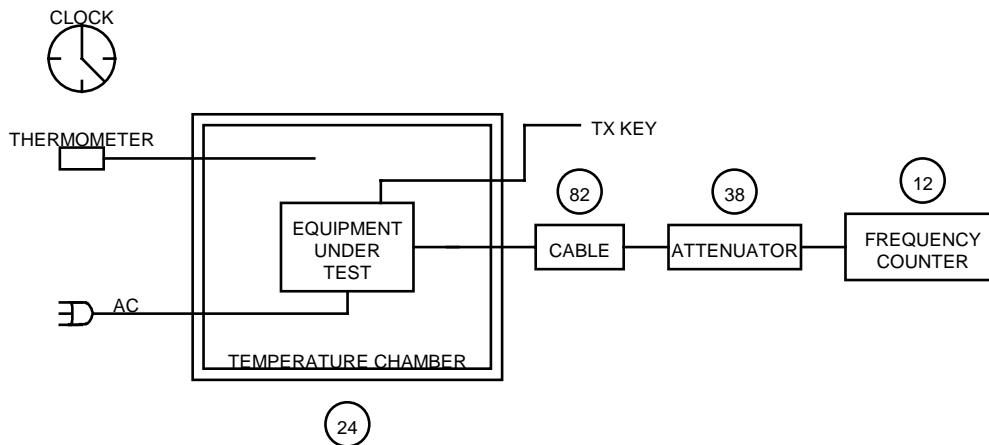

NAME OF TEST: TRANSMITTER FREQUENCY STABILITY (TEMPERATURE)

SPECIFICATION: FCC 47 CFR 2.995(a)(1)

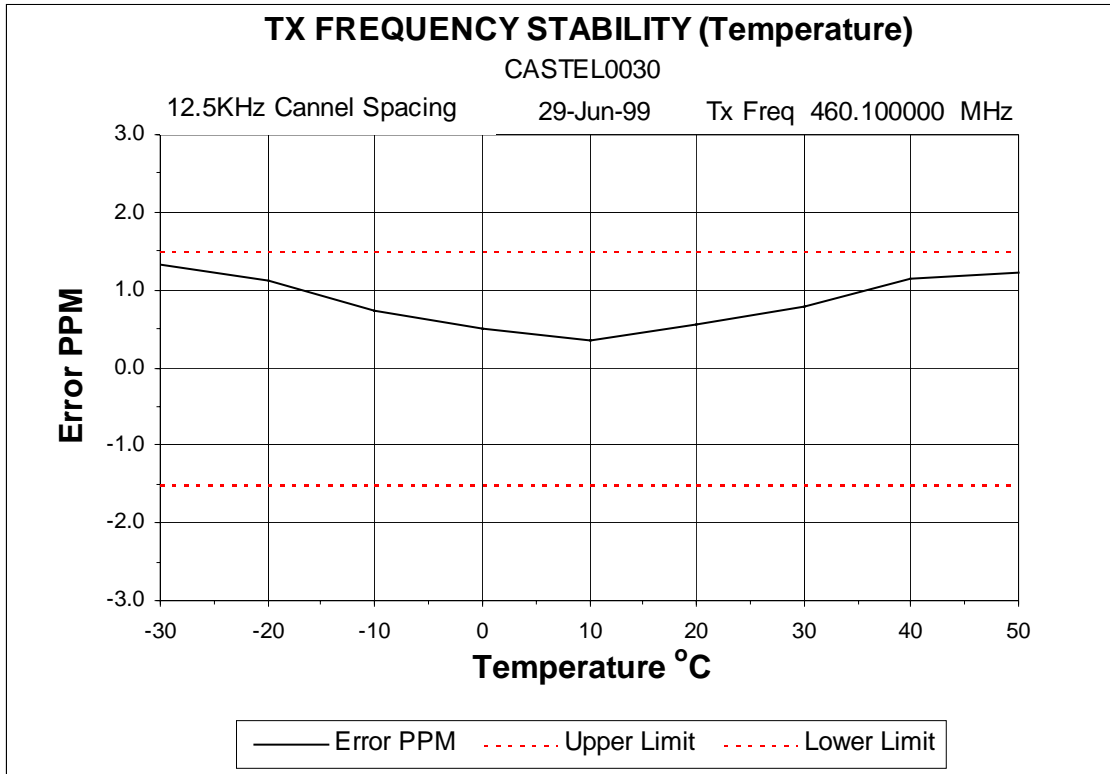

NAME OF TEST: TRANSMITTER FREQUENCY STABILITY (VOLTAGE)

TEST CONDITIONS: Ambient temperature 19.5°C
 Relative humidity 55 %
 Standard Voltage 120VAC

SPECIFICATION: FCC 47 CFR 2.995(b)(1)

GUIDE: TIA/EIA-603 2.2.2

MEASUREMENT PROCEDURE:

1. The Equipment Under Test (EUT) was set up as shown on the following diagram.
2. The EUT was tested for frequency error at an input voltage to the power supply of 85% to 115%, by means of a Variac.
3. The frequency error was recorded in parts per million (PPM)

MEASUREMENT RESULTS:

Channel Spacing (KHz)	Frequency Error (PPM) @ 460.1MHz		
	102VAC	120VAC	138VAC
12.5	0.43	0.45	0.45
25	0.43	0.45	0.45

LIMIT CLAUSE: FCC 47 CFR 90.213

Frequency Range 421MHz to 512MHz

Channel Spacing (KHz)	Frequency Error (PPM)
12.5	1.5
25	2.5

TEST SETUP: See page 40 for test equipment information.

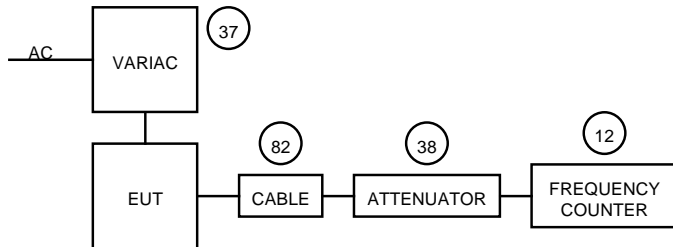

NAME OF TEST: TRANSIENT FREQUENCY BEHAVIOUR

TEST CONDITIONS: Ambient temperature 19.5°C
Relative humidity 55 %
Standard Voltage 120VAC

SPECIFICATION: 90.214

GUIDE: TIA/EIA-603 2.2.19

MEASUREMENT PROCEDURE:

1. The Equipment Under Test (EUT) was set up as shown on the following diagram.
2. Measurements and plots were made following the TIA/EIA procedure.

MEASUREMENT RESULTS:

See the tables and plots on the following pages.

LIMIT CLAUSE: FCC 47 CFR 90.214

See the tables on the following pages.

TEST SETUP: See page 40 for test equipment information.

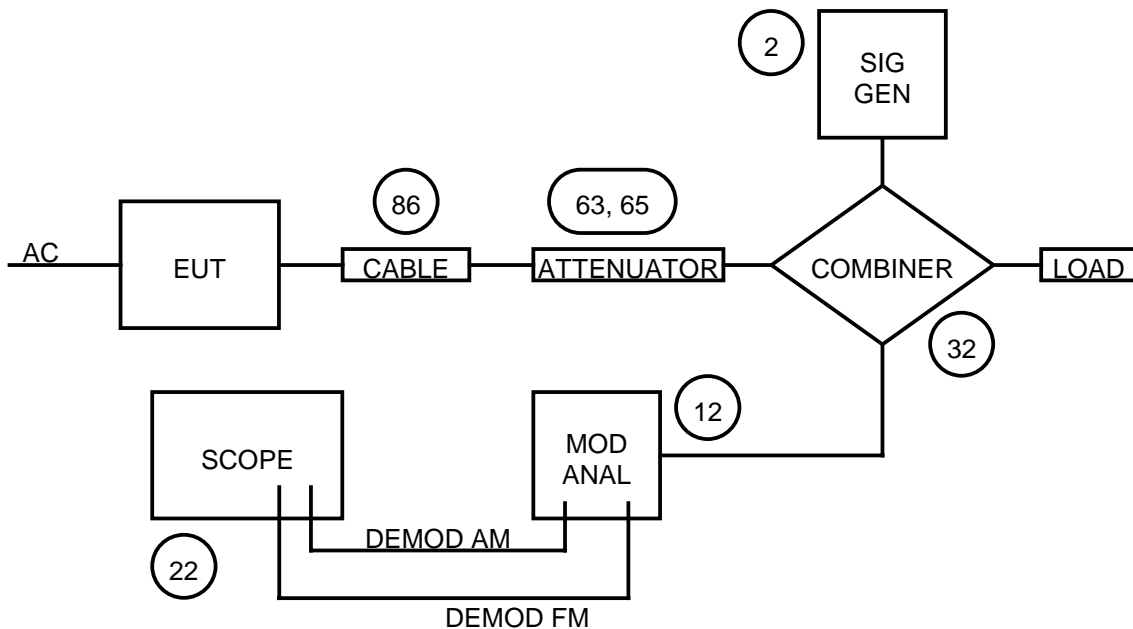

NAME OF TEST: TRANSIENT FREQUENCY BEHAVIOUR

SPECIFICATION: 90.214

12.5KHz CHANNEL SPACING

FREQUENCY	460.1MHz @ 50W Tx	
TRANSIENT RESPONSE PERIOD	CARRIER PEAK VARIATION FROM NOMINAL	
	KEY AON \cong (KHz)	KEY AOFF \cong (KHz)
t1	1.25	N/A
t2	0.27	N/A
t3	N/A	0.27
t2~t3	0.27	
ERROR LIMIT (t2~t3) @1.5PPM (KHz)	0.69	

Confirm that during periods At1 \cong and At3 \cong the frequency difference does not exceed the value of one channel separation.	YES	NO
	Y	
Confirm that during the period At2 \cong the frequency difference does not exceed half a channel separation.	YES	NO
	Y	
Confirm that during the period At2 \cong to At3 \cong the frequency difference does not exceed the frequency error limit	YES	NO
	Y	

LIMITS: 12.5KHz CHANNEL SPACING

TRANSIENT PERIODS	MAXIMUM FREQUENCY DIFFERENCE (KHz)	FREQUENCY RANGE 421-512 MHz
t1 (mS)	\forall 12.5	10 mS
t2 (mS)	\forall 6.25	25 mS
t3 (mS)	\forall 12.5	10 mS

NAME OF TEST: TRANSIENT FREQUENCY BEHAVIOUR

SPECIFICATION: 90.214

12.5KHz CHANNEL SPACING 50W KEY-ON

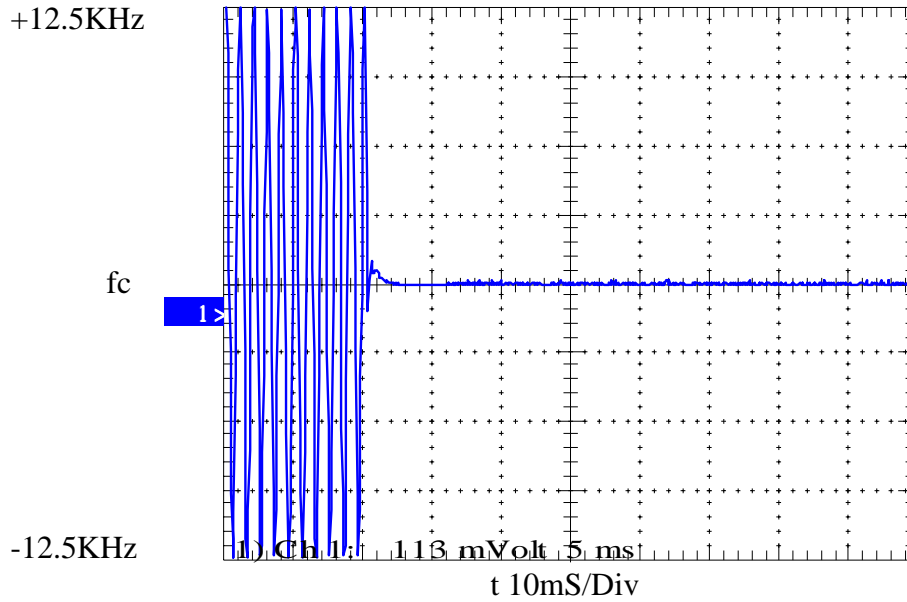

12.5KHz CHANNEL SPACING 50W KEY-OFF

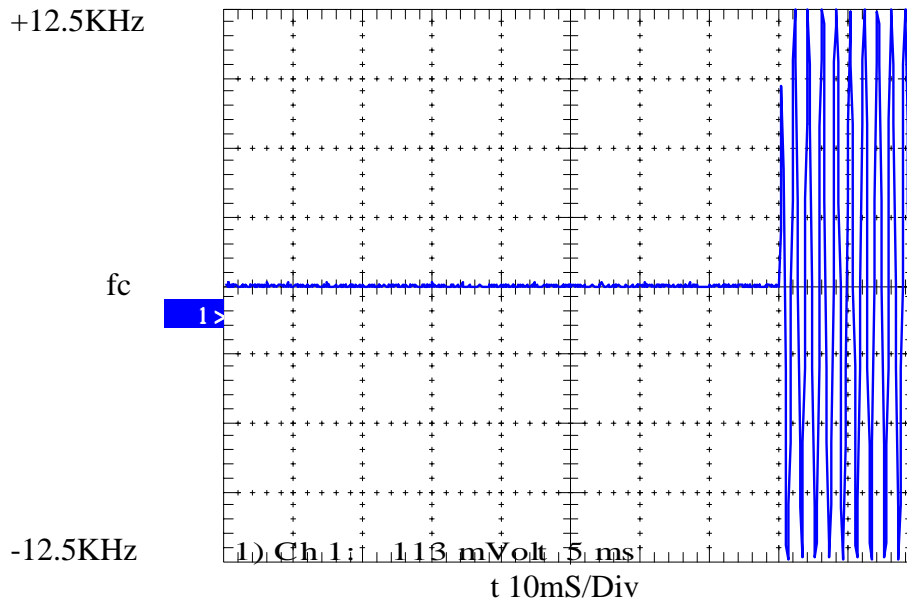

NAME OF TEST: TRANSIENT FREQUENCY BEHAVIOUR

SPECIFICATION: 90.214

12.5KHz CHANNEL SPACING

FREQUENCY	460.1MHz @ 10W Tx	
TRANSIENT RESPONSE PERIOD	CARRIER PEAK VARIATION FROM NOMINAL	
	KEY AON \cong (KHz)	KEY AOFF \cong (KHz)
t1	0.96	N/A
t2	0.27	N/A
t3	N/A	0.27
t2~t3	0.27	
ERROR LIMIT (t2~t3) @1.5PPM (KHz)	0.69	

Confirm that during periods At1 \cong and At3 \cong the frequency difference does not exceed the value of one channel separation.	YES	NO
	Y	
Confirm that during the period At2 \cong the frequency difference does not exceed half a channel separation.	YES	NO
	Y	
Confirm that during the period At2 \cong to At3 \cong the frequency difference does not exceed the frequency error limit	YES	NO
	Y	

LIMITS: 12.5KHz CHANNEL SPACING

TRANSIENT PERIODS	MAXIMUM FREQUENCY DIFFERENCE (KHz)	FREQUENCY RANGE 421-512 MHz
t1 (mS)	\forall 12.5	10 mS
t2 (mS)	\forall 6.25	25 mS
t3 (mS)	\forall 12.5	10 mS

NAME OF TEST: TRANSIENT FREQUENCY BEHAVIOUR

SPECIFICATION: 90.214

12.5KHz CHANNEL SPACING 10W KEY-ON

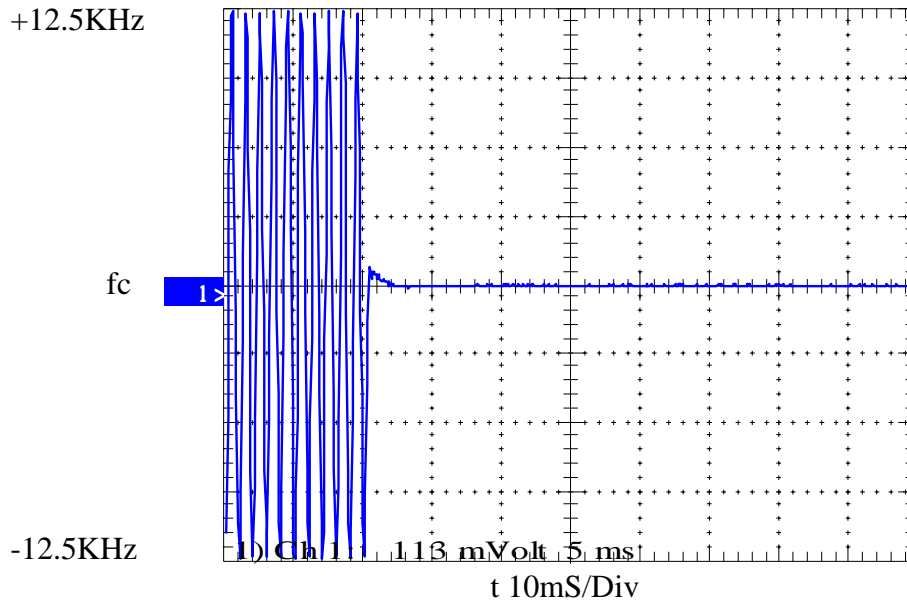

12.5KHz CHANNEL SPACING 10W KEY-OFF

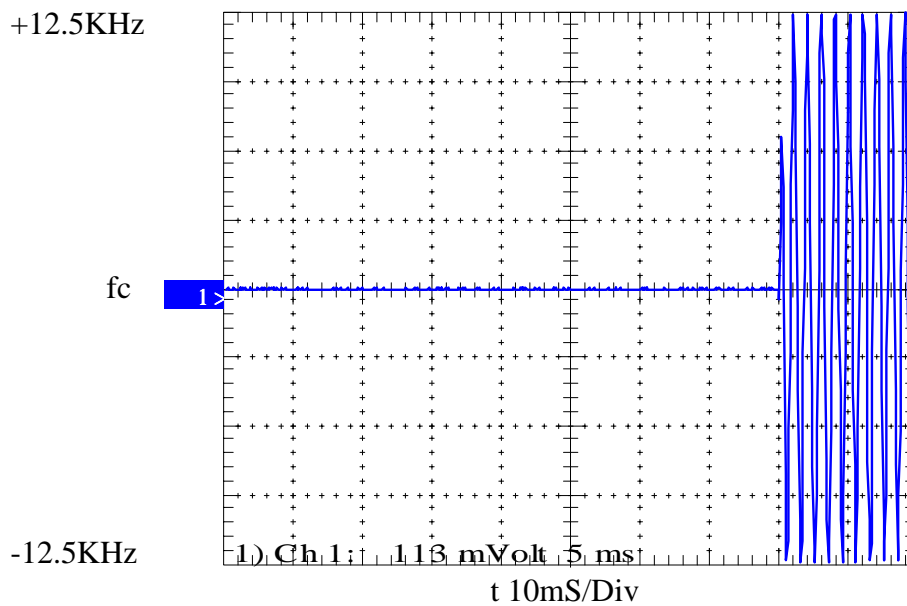

NAME OF TEST: TRANSIENT FREQUENCY BEHAVIOUR

SPECIFICATION: 90.214

25KHz CHANNEL SPACING

FREQUENCY	460.1MHz @ 50W Tx	
TRANSIENT RESPONSE PERIOD	CARRIER PEAK VARIATION FROM NOMINAL	
	KEY AON \cong (KHz)	KEY AOFF \cong (KHz)
t1	3.12	N/A
t2	0.27	N/A
t3	N/A	0.27
t2~t3	0.27	
ERROR LIMIT (t2~t3) @2.5PPM (KHz)	1.38	

Confirm that during periods At1 \cong and At3 \cong the frequency difference does not exceed the value of one channel separation.	YES	NO
	Y	
Confirm that during the period At2 \cong the frequency difference does not exceed half a channel separation.	YES	NO
	Y	
Confirm that during the period At2 \cong to At3 \cong the frequency difference does not exceed the frequency error limit	YES	NO
	Y	

LIMITS: 25KHz CHANNEL SPACING

TRANSIENT PERIODS	MAXIMUM FREQUENCY DIFFERENCE (KHz)	FREQUENCY RANGE 421-512 MHz
t1 (mS)	∇ 25	10 mS
t2 (mS)	∇ 12.5	25 mS
t3 (mS)	∇ 25	10 mS

NAME OF TEST: TRANSIENT FREQUENCY BEHAVIOUR

SPECIFICATION: 90.214

25KHz CHANNEL SPACING 50W KEY-ON

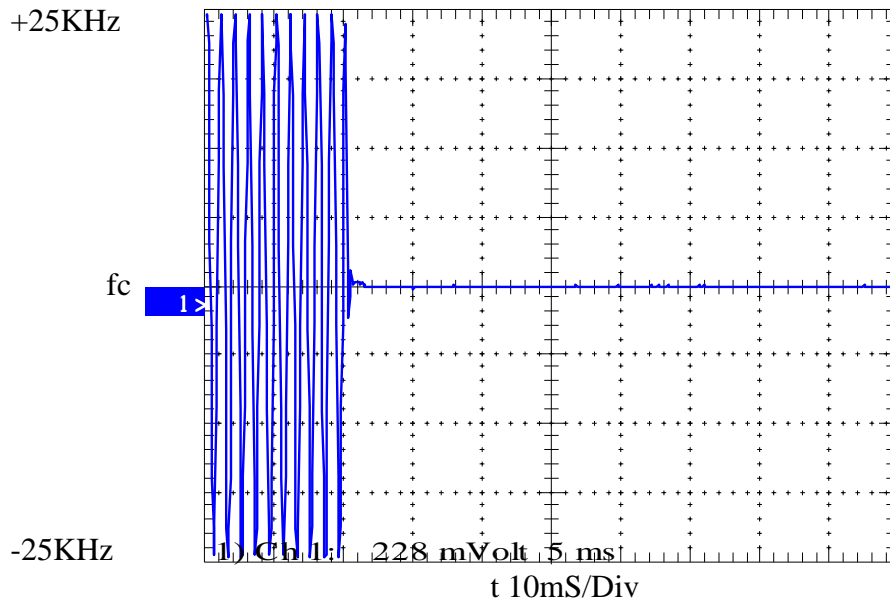

25KHz CHANNEL SPACING 50W KEY-OFF

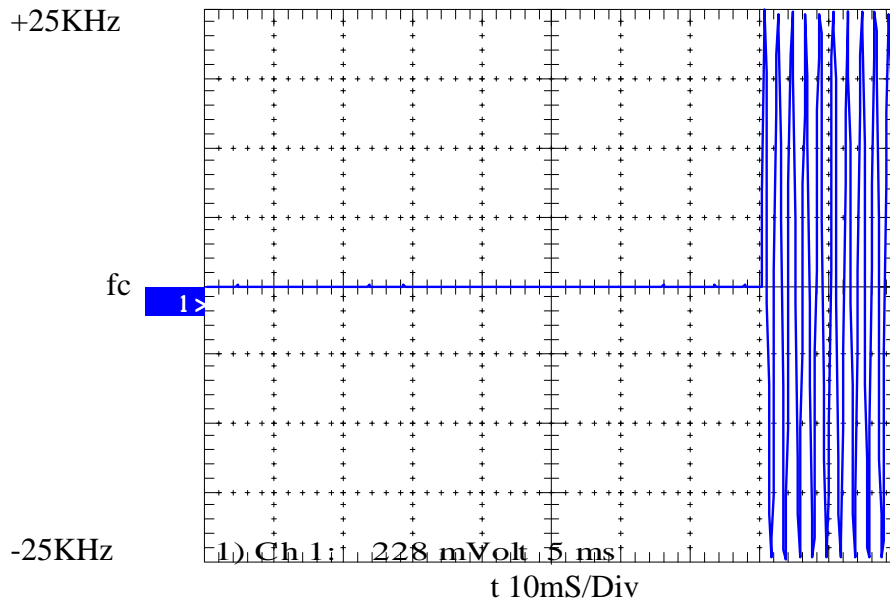

NAME OF TEST: TRANSIENT FREQUENCY BEHAVIOUR

SPECIFICATION: 90.214

25KHz CHANNEL SPACING

FREQUENCY	460.1MHz @ 10W Tx	
TRANSIENT RESPONSE PERIOD	CARRIER PEAK VARIATION FROM NOMINAL	
	KEY AON \cong (KHz)	KEY AOFF \cong (KHz)
t1	2.90	N/A
t2	0.27	N/A
t3	N/A	0.27
t2~t3	0.27	
ERROR LIMIT (t2~t3) @2.5PPM (KHz)	1.38	

Confirm that during periods At1 \cong and At3 \cong the frequency difference does not exceed the value of one channel separation.	YES	NO
	Y	
Confirm that during the period At2 \cong the frequency difference does not exceed half a channel separation.	YES	NO
	Y	
Confirm that during the period At2 \cong to At3 \cong the frequency difference does not exceed the frequency error limit	YES	NO
	Y	

LIMITS: 25KHz CHANNEL SPACING

TRANSIENT PERIODS	MAXIMUM FREQUENCY DIFFERENCE (KHz)	FREQUENCY RANGE 421-512 MHz
t1 (mS)	∇ 25	10 mS
t2 (mS)	∇ 12.5	25 mS
t3 (mS)	∇ 25	10 mS

NAME OF TEST: TRANSIENT FREQUENCY BEHAVIOUR

SPECIFICATION: 90.214

25KHz CHANNEL SPACING 10W KEY-ON

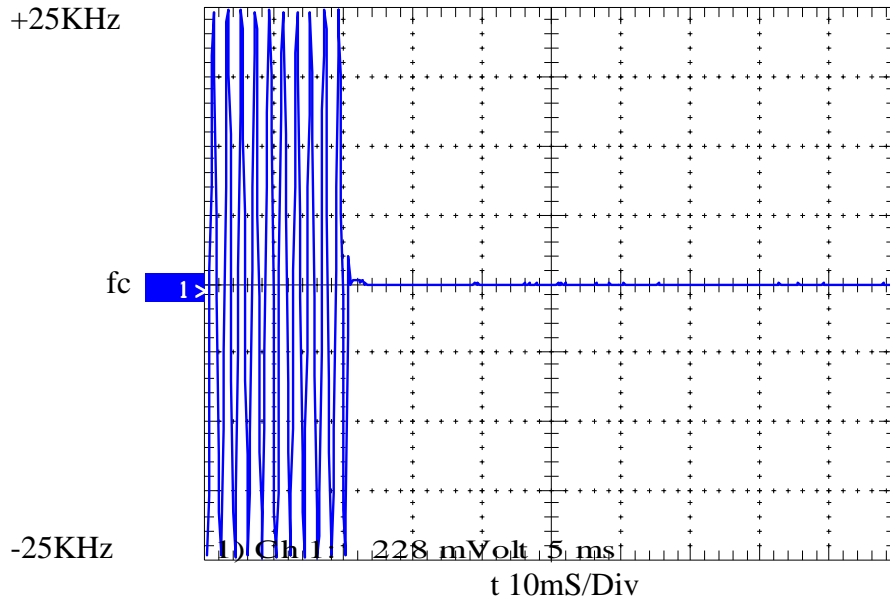

25KHz CHANNEL SPACING 10W KEY-OFF

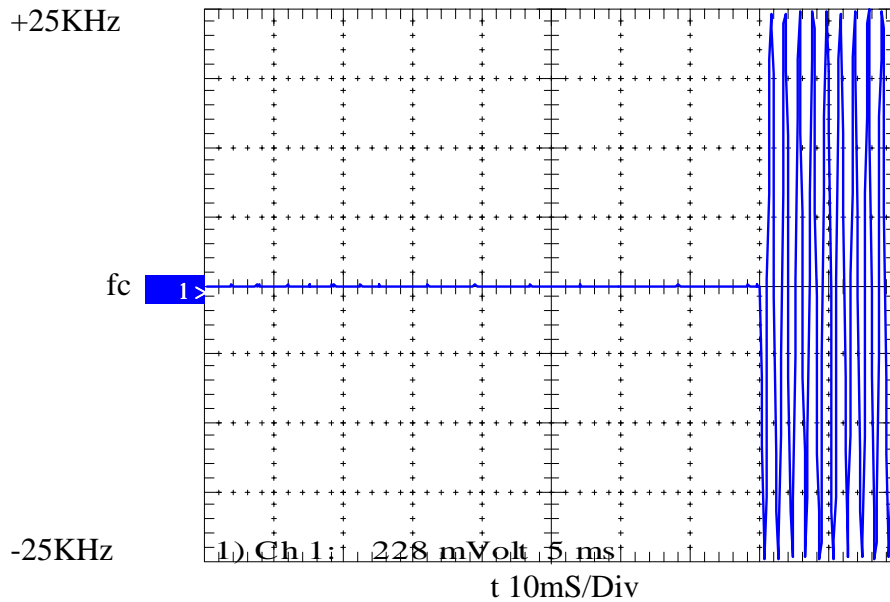

TEST EQUIPMENT LIST

FCC ID: CASTEL0030

To facilitate inclusion on each page, the test equipment used is identified (numbered) and listed against the related test in the report.

No	Equipment Type	Model number	Serial Number	Tait ID:
01	Signal Generator	HP 8642B (Opt 001)	2512A00176	E3064
02	Signal Generator	HP8648A	3430U00344	E3579
03	Signal Generator	HP8656A	2142A02103	E3063
04	Signal Generator	HP8648C	3443U00543	E3558
05	Signal Generator	SMY01 1062.5502.11	841736/019	E3553
10	Spectrum Analyser	HP8596E (Opt 140)	3346A00213	E3427
11	Modulation Analyser	HP8901B (Opt 002)	2441A00393	E3073
12	Modulation Analyser	FMA 0852.8500.52	842541/001	E3554
13	Audio Analyser	HP8903A	2308A02597	E3074
14	Power Head	HP11722A	2320A00688	E3307
15	Power Meter	NRVS 1020.1809.02	841954/005	E3555
16	Power Sensor	URV5-Z4 395.1619.55	841.498/003	E3557
20	Power Supply	HP6032A	2441A-0041	E3075
21	Power Supply	NGSM32/10 192.0810.31	Fnr 434	E3556
22	Oscilloscope	Tektronics TDS 340	B013611	E3585
23	Universal Counter	Goldstar FC-2015U	600801	E3550
24	Environmental Chamber	Contherm Spatial Cal	E3397	E3397
24	Environmental Chamber	Contherm Temp Control	E3397	E3397
25	Portable Hygromer (ASL)	Rotronic A1	2070300/38	N/A
25	Whirling Hygromer	Casella 3156 / 82	TA004	TA004
30	Directional Coupler	HP778D-012	1144 07392	E3292
31	4 Port Combiner (CAST)	DVU4, 3W 201.4018.03	300729/47	E3623
32	4 Port Combiner	DVU4, 3W 201.4018.03	300971/28	E3572
33	3 Port Combiner	Weinschel 1506A, 1W	LD858	E3672
34	Mixer Spurious Emission	Tait (3.2G# Rfx# 4.0G)	E3661	E3661
35	Mixer Transient ACP	Minicircuits ZAD-11	77031	E3394

TEST EQUIPMENT LIST (Cont.)

No	Equipment Type	Model number	Serial Number	Tait ID:	
36	Voltmeter	HP3478A	2545A25838	E1559	
37	Variact	Yamabishi S-260-5	TX-533	E1737	
38	RX and TX, RF Paths	Tait CAST Interface	E3067	E3067	
40	Reference Dipoles	Emco 3121C-DB1	9510-1164	E3559	
41	Antenna	Biconical	9307-1680	E3033	
42	Reference Horn Antenna	Emco DRG 3115	9512-4638	E3560	
43	Horn Antenna	Emco DRG 3115	2084	E3076	
44	Corner 175-420 MHz	Ailtech DM 105A-T2	J1417-103	E3031	
45	Corner 400-1000 MHz	Ailtech DM 105A-T3	J1418-108	E3036	
46	S-LINE TEM CELL	1089.9296.02	338232/003	E3636	
50	Amplifier AR 1M-1000M	25W1000A	20444	E3637	
51	Amplifier AR 10K-250M	25A250	16373	E3570	
52	Amplifier +21.7 dB	Tait ZFL-1000LN	E3660	E3360	
53	RF Filter 21.4M (CAST)	Tait NDK 21G-6DT	E3069	E3069	
54	RF Filter 21.4M (ACP)	Tait NDK 21G-6DT	RA-7'	E3249	
55	Filter Notch	Tait	N/A	?	
56	Filter High Pass	Tait	Mhz	N/A	?
57	Filter Low Pass	Tait	Mhz	N/A	?
60	RF Attenuator 250W	Weinschel 45-30-34	JW663	E3386	
61	RF Attenuator 150W	Weinschel 40-20-33	CJ404	E3387	
62	RF Attenuator 150W	Weinschel 57-10-34	LB590	E3674	
63	RF Attenuator 150W	Weinschel 40-06-34	KV457	E3561	
64	RF Attenuator 50W	Weinschel 24-10-34	AL0401	E3388	
65	RF Attenuator 50W	Weinschel 24-20-44	AW1266	E3562	

TEST EQUIPMENT LIST (Cont.)

No	Equipment Type	Model number	Serial Number	Tait ID:
66	RF Attenuator 25W	Weinschel 33-20-33	BD5871	E3673
67	RF Attenuator150W(CAST)	Weinschel 40-20-33	CJ405	3366/82
70	RF Load 150W	Byrd 8166	524	E3625
71	RF Load 50 W	Weinschel F1426	BF0487	E3675
72	RF Load 50 W	Weinschel F1426	AE2490	E3624
73	RF Termination 20W	Deltec	118.001	E3626
74	RF Termination 2 W	MCL NTRM-50	951215	E3574
75	RF Termination 2 W	MCL NTRM-50	954214	E3575
76	RF Termination 2 W	MCL NTRM-50	954214	E3576
80	20 M Coax Cable	RG214/U 50 (Ext Cal)	CBL01	E3659
81	2 M Coax Cable	RG213/U 50 (Ext Cal)	CBL02	E3658
82	3 M Coax Cable (BLUE)	Suhner Sucoflex 104A	25033 / 4A	E3694
83	1 M Coax Cable (BLUE)	Suhner Sucoflex 104A	25006 / 4A	E3693
84	1 M Coax Cable (BLUE)	Suhner Sucoflex 104A	25005 / 4A	E3692
85	1 M Coax Cable (BLUE)	Suhner Sucoflex 104A	25004 / 4A	E3691
86	1 M Coax Cable (BLUE)	Suhner Sucoflex 104A	25003 / 4A	E3690
87	Audio Analyser	HP8903B	2818A04275	E3710
88	Spectrum Analyser	HP8562E	3821A00799	E3715
89	Field Strength Meter	Holiday HI-422	95661	E3630
90	Power Supply	HP6012B	2524A00616	E3712
91	20 M Coax Cable	RG214/U 50 (Ext Cal)	3404	24/08/99
92	LISN	EMCO 3825/2	9204-1961	E3040