

Sub-part
2.983(e):

TEST AND MEASUREMENT DATA

All tests and measurement data shown were performed in accordance with FCC Rules and Regulations, Volume II; Part 2, Sub-part J, Sections 2.981, 2.983, 2.985, 2.987, 2.989, 2.991, 2.993, 2.995, 2.997, 2.999 and the following individual Parts:

- ___ 21 - Domestic Public Fixed Radio Services
- ___ 22 - Public Mobile Services
- ___ 22 Subpart H - Cellular Radiotelephone Service
- ___ 22.901(d) - Alternative technologies and auxiliary services
- ___ 23 - International Fixed Public Radiocommunication services
- ___ 24 - Personal Communications Services
- ___ 74 Subpart H - Low Power Auxiliary Stations
- ___ 80 - Stations in the Maritime Services
- ___ 80 Subpart E - General Technical Standards
- ___ 80 Subpart F - Equipment Authorization for Compulsory Ships
- ___ 80 Subpart K - Private Coast Stations and Marine Utility Stations
- ___ 80 Subpart S - Compulsory Radiotelephone Installations for Small Passenger Boats
- ___ 80 Subpart T - Radiotelephone Installation Required for Vessels on the Great Lakes
- ___ 80 Subpart U - Radiotelephone Installations Required by the Bridge-to-Bridge Act
- ___ 80 Subpart V - Emergency Position Indicating Radiobeacons (EPIRB'S)
- ___ 80 Subpart W - Global Maritime Distress and Safety System (GMDSS)
- ___ 80 Subpart X - Voluntary Radio Installations
- ___ 87 - Aviation Services
- x 90 - Private Land Mobile Radio Services
- ___ 94 - Private Operational-Fixed Microwave Service
- ___ 95 Subpart A - General Mobile Radio Service (GMRS)
- ___ 95 Subpart C - Radio Control (R/C) Radio Service
- ___ 95 Subpart D - Citizens Band (CB) Radio Service
- ___ 95 Subpart E - Family Radio Service
- ___ 95 Subpart F - Interactive Video and Data Service (IVDS)
- ___ 101 - Fixed Microwave Services

STANDARD TEST CONDITIONS
and
ENGINEERING PRACTICES

Except as noted herein, the following conditions and procedures were observed during the testing:

ROOM TEMPERATURE	= 25±5°C
ROOM HUMIDITY	= 20-50%
D.C. SUPPLY VOLTAGE, Vdc	= N/A
A.C. SUPPLY VOLTAGE, Vac	= 120
A.C. SUPPLY FREQUENCY, Hz	= 60

Prior to testing, the EUT was tuned up in accordance with the manufacturer's alignment procedures. All external gain controls were maintained at the position of maximum and/or optimum gain throughout the testing.

Measurement results, unless otherwise noted, are worst case measurements.

PAGE NO.

6.

CASTEL0009

NAME OF TEST:

Carrier Output Power (Conducted)

SPECIFICATION:

FCC: 47 CFR 2.985(a)
IC: RSS-119, Section 6.2

GUIDE:

TIA/EIA-603, Paragraph 2.2.1

TEST CONDITIONS:

Standard Temperature and Humidity (S. T. & H.)

TEST EQUIPMENT:

As per attached page

MEASUREMENT PROCEDURE

1. The EUT was connected to a resistive coaxial attenuator of normal load impedance, and the unmodulated output power was measured by means of an R. F. Power Meter.
2. Measurement accuracy is $\pm 3\%$.

MEASUREMENT RESULTS

<u>NOMINAL, MHz</u>	<u>R. F. POWER OUTPUT, WATTS</u>	
460.1	5	25

SUPERVISED BY:

MORTON FLOM, P. Eng.

TRANSMITTER POWER CONDUCTED MEASUREMENTS

TEST 1: R. F. POWER OUTPUT
 TEST 2: FREQUENCY STABILITY

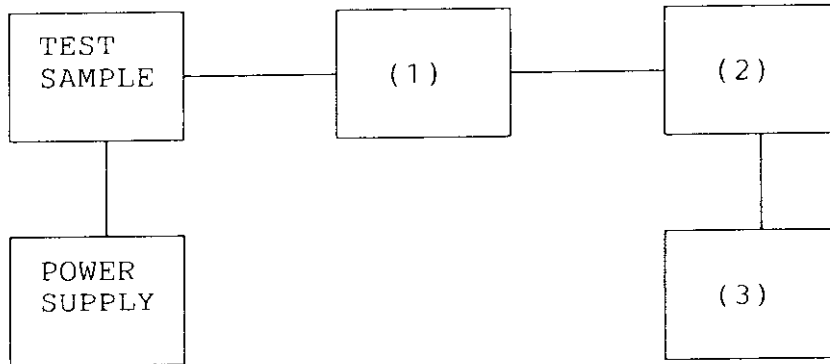

(1) COAXIAL ATTENUATOR

NARDA 766-10	---
SIERRA 661A-30	<u>x</u>
BIRD 8329 (30 dB)	---
_____	---

(2) POWER METERS

HP 435A	---
HP 436A	<u>x</u>
HP 8901A POWER MODE	<u>x</u>
_____	---

(3) FREQUENCY COUNTER

HP 5383A	---
HP 5334B	<u>x</u>
HP 8901A FREQUENCY MODE	<u>x</u>
_____	---

PAGE NO. 8. CASTEL0009
NAME OF TEST: Unwanted Emissions (Transmitter Conducted)
SPECIFICATION: FCC: 47 CFR 2.991
IC: RSS-119, Section 6.3
GUIDE: TIA/EIA-603, Paragraph 2.2.13
TEST CONDITIONS: S. T. & H.
TEST EQUIPMENT: As per attached page

MEASUREMENT PROCEDURE

1. The emissions were measured for the worst case as follows:
 - (a): within a band of frequencies defined by the carrier frequency plus and minus one channel.
 - (b): from the lowest frequency generated in the EUT and to at least the 10th harmonic of the carrier frequency, or 40 GHz, whichever is lower.
2. The magnitude of spurious emissions which are attenuated more than 20 dB below the permissible value need not be specified.
3. MEASUREMENT RESULTS: ATTACHED FOR WORST CASE

FREQUENCY OF CARRIER, MHz = 460.1
SPECTRUM SEARCHED, GHz = 0 to $10 \times F_C$
MAXIMUM RESPONSE, Hz = 2510
ALL OTHER EMISSIONS = ≥ 20 dB BELOW LIMIT
LIMIT, dBc: $-(43 + 10 \text{ LOG } P_0)$ = -50 (5 Watts)
-57 (25 Watts)

SUPERVISED BY:

MORTON FLOM, P. Eng.

TRANSMITTER SPURIOUS EMISSION

TEST A. OCCUPIED BANDWIDTH (IN-BAND SPURIOUS)
 TEST B. OUT-OF-BAND SPURIOUS

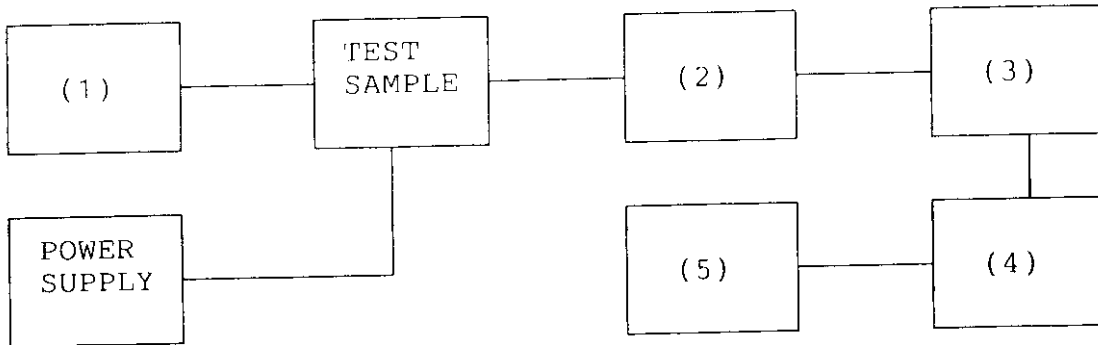

- | | | |
|-----|-----------------------------------|----------|
| (1) | <u>AUDIO OSCILLATOR/GENERATOR</u> | |
| | HP 204D | --- |
| | HP 8903A | --- |
| | HP 3312A | <u>x</u> |
| | | <u>x</u> |
| (2) | <u>COAXIAL ATTENUATOR</u> | |
| | NARDA 766-10 | --- |
| | SIERRA 661A-30 | <u>x</u> |
| | BIRD 8329 (30 dB) | <u>x</u> |
| (3) | <u>FILTERS; NOTCH, HP, LP, BP</u> | |
| | CIRQTEL FHT | --- |
| | EAGLE TNF-1 | <u>x</u> |
| | PHELPS DODGE PD-495-8 | --- |
| (4) | <u>SPECTRUM ANALYZER</u> | |
| | HP 8566B | <u>x</u> |
| | HP 8563E | --- |
| (5) | <u>SCOPE</u> | |
| | HP 1741A | --- |
| | HP 181T | --- |
| | TEK 935 | --- |
| | HP 54502A | --- |

PAGE NO.
G87K004

10.1.

CASTEL0009

TRANSMITTER SPURIOUS EMISSIONS (CONDUCTED)
POWER: LOW

FREQUENCY TUNED, MHz	FREQUENCY EMISSION, MHz	LEVEL, dBm	LEVEL, dBc	LEVEL, μ W
460.100	920.565	-42.2	-79.1	0
460.100	1380.497	-42.3	-79.2	0
460.100	1840.672	-41.1	-78.0	0
460.100	2300.079	-40.1	-77.0	0
460.100	2760.216	-43.2	-80.1	0
460.100	3220.716	-42.2	-79.1	0
460.100	3680.797	-43.6	-80.5	0
460.100	4140.478	-43.9	-80.8	0
460.100	4601.456	-40.9	-77.8	0
460.100	5061.356	-42.2	-79.1	0
460.100	5521.093	-42.8	-79.7	0
460.100	5981.364	-37.1	-74.0	0
460.100	6441.681	-36.9	-73.8	0
460.100	6901.952	-36.8	-73.7	0

PAGE NO.

10.2.

CASTEL0009

G87K003

TRANSMITTER SPURIOUS EMISSIONS (CONDUCTED)

POWER: HIGH

FREQUENCY TUNED, MHz	FREQUENCY EMISSION, MHz	LEVEL, dBm	LEVEL, dBc	LEVEL, μ W
460.100	919.995	-31.5	-75.4	1
460.100	1380.600	-31.8	-75.7	1
460.100	1839.904	-29.8	-73.7	1
460.100	2300.948	-30.5	-74.4	1
460.100	2760.195	-32.4	-76.3	1
460.100	3220.697	-33.3	-77.2	0
460.100	3680.354	-32.8	-76.7	1
460.100	4141.036	-32.7	-76.6	1
460.100	4601.025	-32.7	-76.6	1
460.100	5061.169	-32.4	-76.3	1
460.100	5521.475	-31.4	-75.3	1
460.100	5981.088	-26.2	-70.1	2
460.100	6441.015	-27.1	-71.0	2
460.100	6901.951	-26.0	-69.9	3

PAGE NO. 11.1. CASTEL0009
NAME OF TEST: Field Strength of Spurious Radiation
SPECIFICATION: FCC: 47 CFR 2.993(a)
IC: N/A
GUIDE: TIA/EIA-603, Section 2.2.12
TEST CONDITIONS: S. T. & H.
TEST EQUIPMENT: AS PER ATTACHED PAGE

MEASUREMENT PROCEDURE

1. A description of the measurement facilities was filed with the FCC and was found to be in compliance with the requirements of Section 15.38, by letter from the FCC dated March 3, 1997, FILE 31040/SIT. All pertinent changes will be reported to the Commission by up-date prior to March 2000.
2. At first, in order to locate all spurious frequencies and approximate amplitudes, and to determine proper equipment functioning, the test sample was set up at a distance of three meters from the test instrument. Valid spurious signals were determined by switching the power on and off.
3. In the field, the test sample was placed on a wooden turntable above ground at three (or thirty) meters away from the search antenna. The test sample was connected to an R.F. Wattmeter and a 50 ohm dummy load, and adjusted to its rated output.

In order to obtain the maximum response at each spurious frequency, the turntable was rotated. Also, the Search Antennas were raised and lowered vertically, and all cables were oriented. Excess power lead was coiled near the power supply.
4. A signal generator, connected with a non-radiating cable to a vertically polarized half-wave antenna (for each frequency involved) was substituted for the transmitter. The Search Antenna was raised and lowered to obtain maximum indicated.
5. The signal generator output was adjusted until a signal level indication equal to that from the transmitter was obtained.
6. Steps 4 and 5 were repeated, using a horizontally polarized half-wave antenna. The higher of the two observations was noted.

PAGE NO. 11.2. CASTEL0009

NAME OF TEST: Field Strength of Spurious Radiation

SPECIFICATION: FCC: 47 CFR 2.993(a)
IC: N/A

MEASUREMENT PROCEDURE (CONT.)

7. Power into the half-wave antenna was calculated from the characteristic impedance of the line, and the voltage output from the signal generator.

8. The level of each spurious radiation with reference to the transmitter power in dB, was calculated from:

$$\text{SPURIOUS LEVEL, dB} = 10 \text{ LOG (Calculated Spurious Power)} \\ \frac{[\text{from para. 7}]}{\text{Tx Power (Wattmeter)}}$$

9. The worst case for all channels is shown.

10. Measurement summary:

FREQUENCY OF CARRIER, MHz	= 460.1
SPECTRUM SEARCHED, GHz	= 0 to $10 \times F_c$
ALL OTHER EMISSIONS	= ≥ 20 dB BELOW LIMIT
LIMIT, dBc	= -57 (25 Watts) -50 (5 Watts)

11. Measurement results: ATTACHED FOR WORST CASE

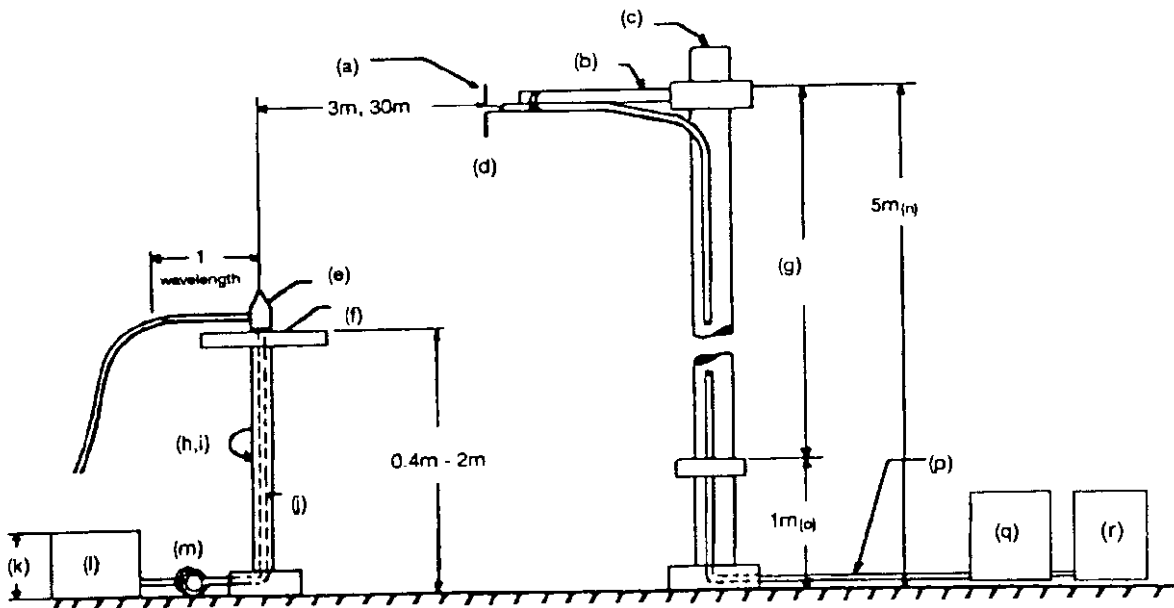
RADIATED TEST SETUP

NOTES:

- (a) Search Antenna - Rotatable on boom.
- (b) Non-metallic boom.
- (c) Non-metallic mast.
- (d) Adjustable horizontally.
- (e) Equipment Under Test.
- (f) Turntable.
- (g) Boom adjustable in height.
- (h) External control cables routed horizontally at least one wavelength.
- (i) Rotatable.
- (j) Cables routed through hollow turntable center.
- (k) 30 cm or less.
- (l) External power source.
- (m) 10 cm diameter coil of excess cable.
- (n) 25 cm (V), 1 m-7 m (V, H).
- (o) 25 cm from bottom end of 'V', 1 m normally.
- (p) Calibrated Cable at least 10 m in length.
- (q) Amplifier (optional).
- (r) Spectrum Analyzer.

TRANSMITTER SPURIOUS EMISSIONS (RADIATED FIELD STRENGTH)

ALL OTHER EMISSIONS = \geq 20 dB BELOW LIMIT

EMISSION, MHz/HARMONIC	SPURIOUS LEVEL BELOW	
	Lo	Hi
2nd to 10th	< -70	< -65

SUPERVISED BY:

Morton Flom P. Eng.
MORTON FLOM, P. Eng.

PAGE NO. 14. CASTEL0009
NAME OF TEST: Emission Masks (Occupied Bandwidth)
SPECIFICATION: FCC: 47 CFR 2.989(c)(1)
IC: RSS-119, Section 6.4
GUIDE: TIA/EIA-603, Paragraph 2.2.11
TEST CONDITIONS: S. T. & H.
TEST EQUIPMENT: As per previous page

MEASUREMENT PROCEDURE

1. The EUT and test equipment were set up as shown on the following page, with the Spectrum Analyzer connected.
2. For EUTs supporting audio modulation, the audio signal generator was adjusted to the frequency of maximum response and with output level set for ± 2.5 kHz deviation (or 50% modulation). With level constant, the signal level was increased 16 dB.
3. For EUTs supporting digital modulation, the digital modulation mode was operated to its maximum extent.
4. The Occupied Bandwidth was measured with the Spectrum Analyzer controls set as shown on the test results.
5. MEASUREMENT RESULTS: ATTACHED

PAGE 15.1.
SPECTRUM ANALYZER PRESENTATION
TAIT ELECTRONICS, T856-26-0000 (TX)
1998-JUL-20, 12:02, MON

POWER: LOW
MODULATION: NONE

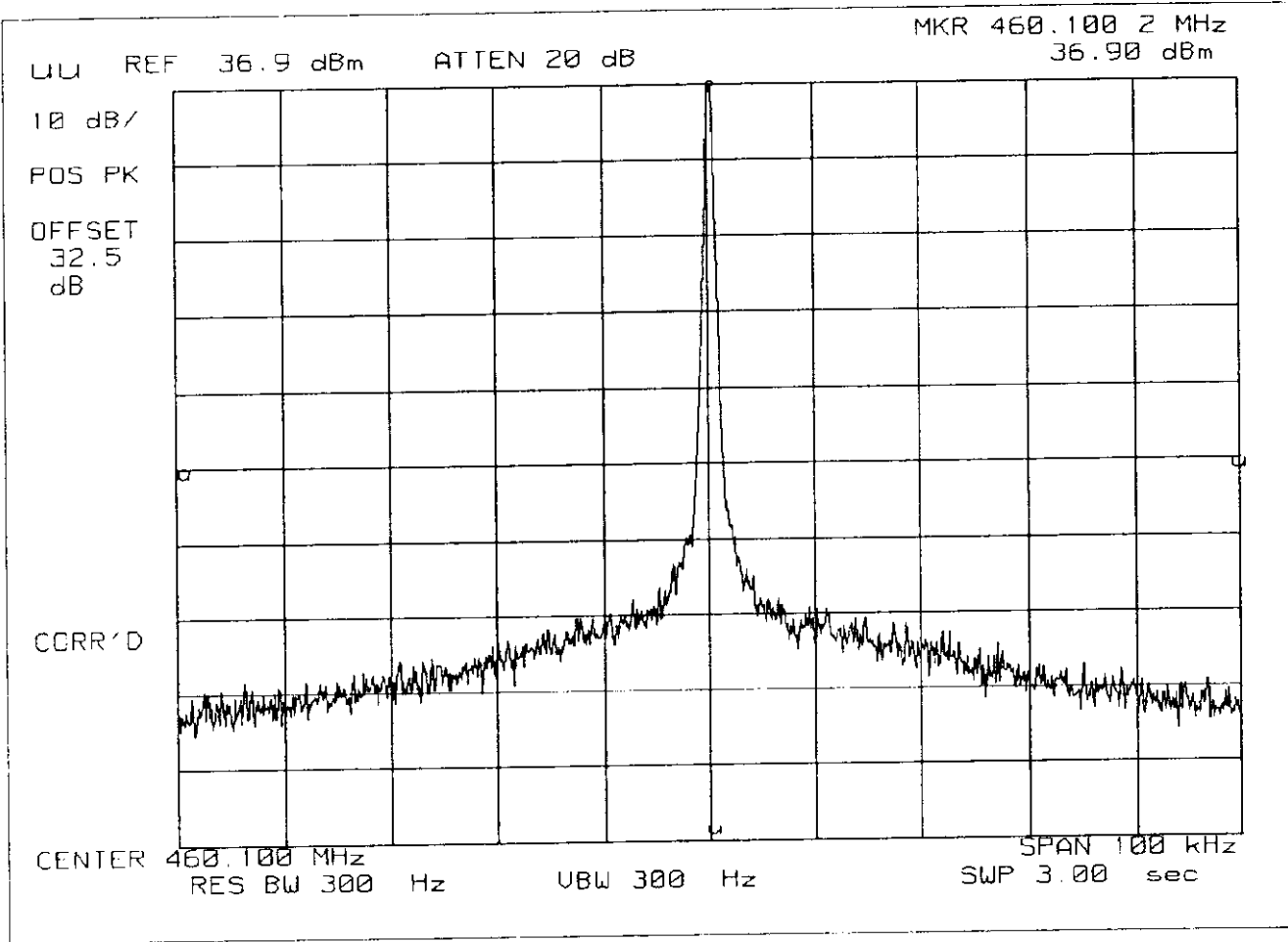

© 1998 BY N. FODR ASSOCIATES, INC. ALL RIGHTS RESERVED

SPECTRUM ANALYZER PRESENTATION
TAIT ELECTRONICS, T856-26-0000 (TX)
1998-JUL-20, 12:12, MON

POWER: LOW
MODULATION: VOICE: 2500 Hz SINE WAVE
MASK: D, VHF/UHF 12.5kHz BW

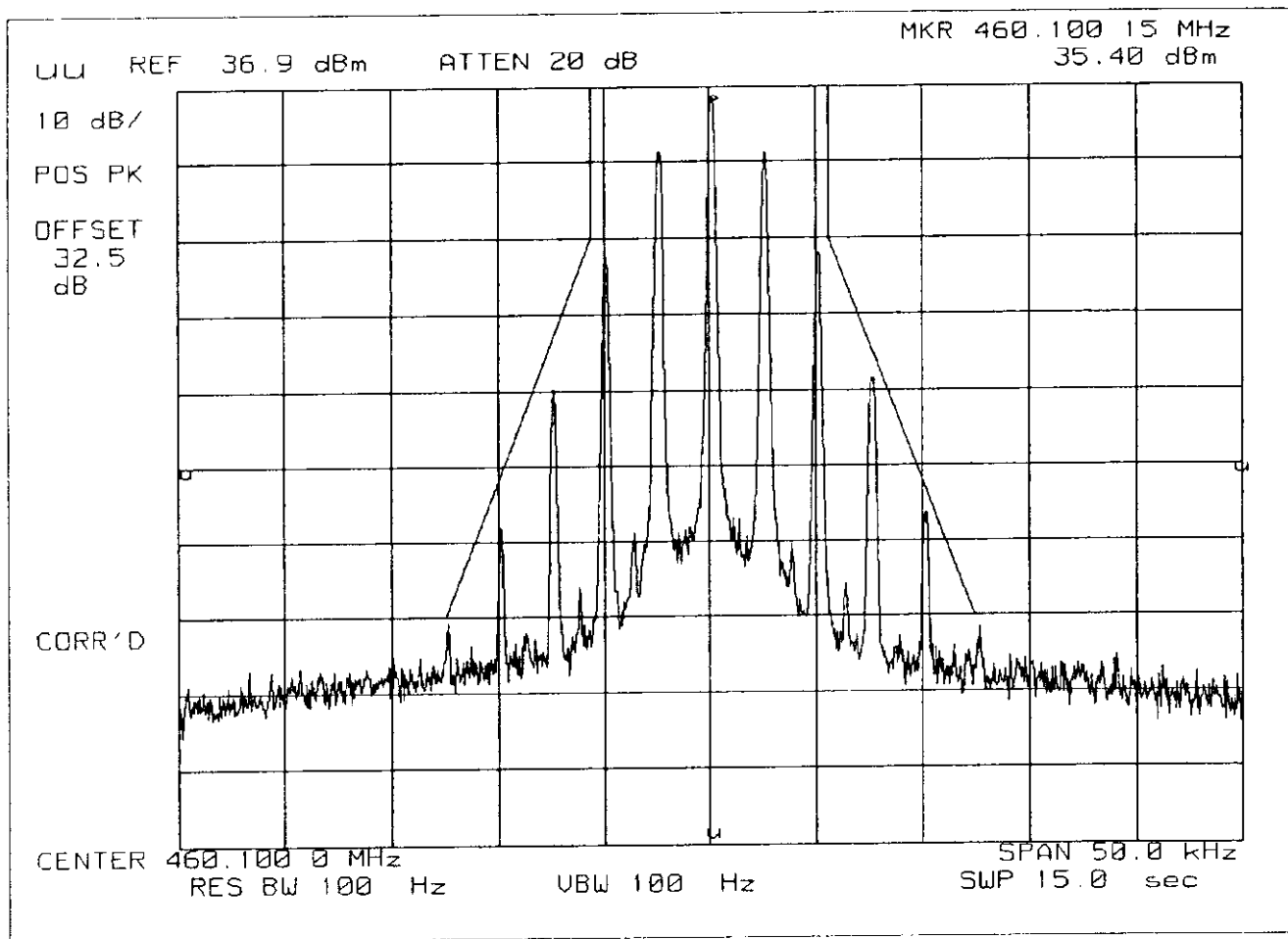

PAGE 15.3.
SPECTRUM ANALYZER PRESENTATION
TAIT ELECTRONICS, T856-26-0000 (TX)
1998-JUL-20, 12:05, MON

POWER: LOW
MODULATION: VOICE: 2500 Hz SINE WAVE
MASK: B, VHF/UHF 25kHz, w/LPF

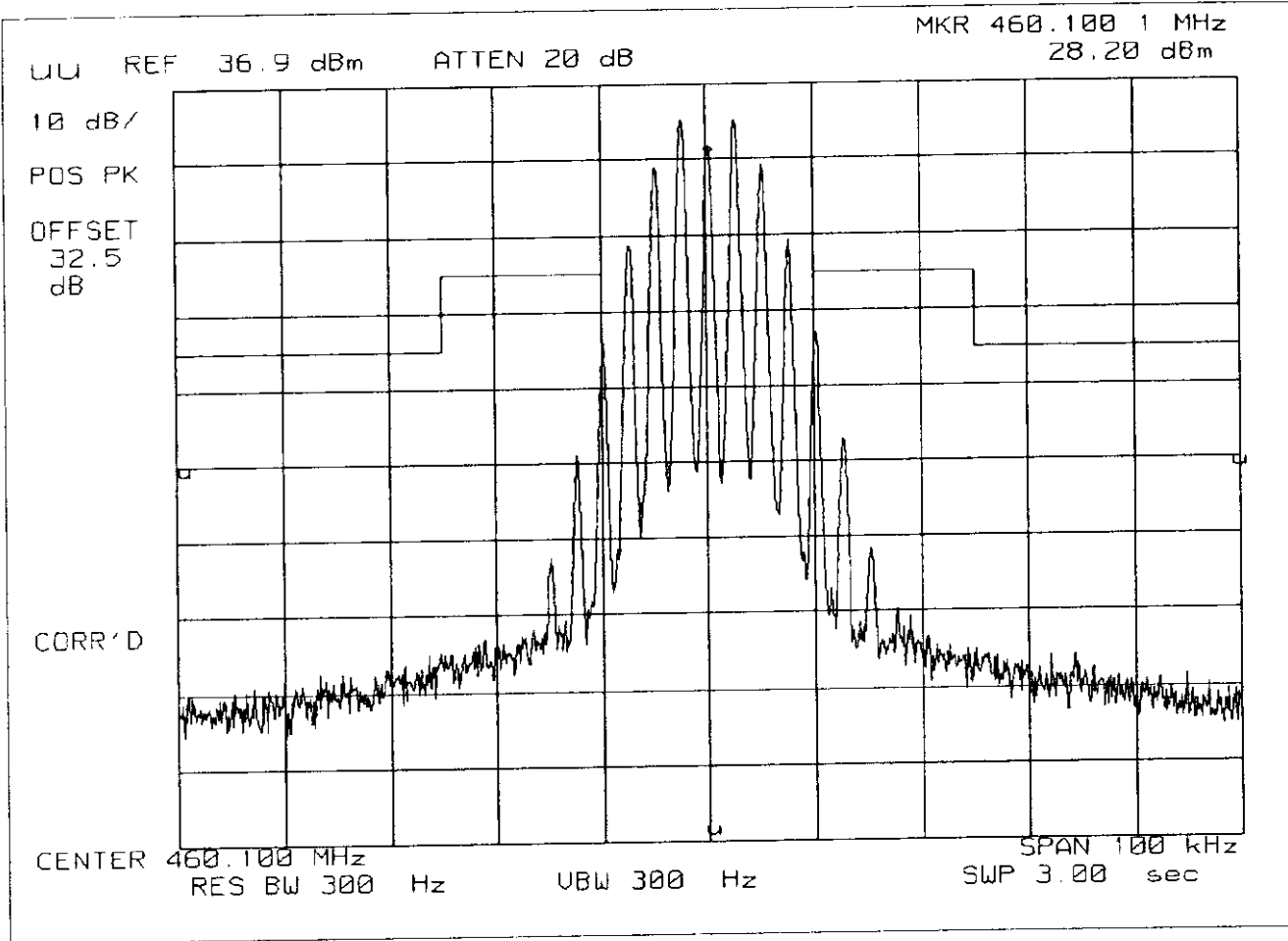

SPECTRUM ANALYZER PRESENTATION
TAIT ELECTRONICS, T856-26-0000 (TX)
1998-JUL-20, 11:59, MON

POWER: HIGH
MODULATION: NONE

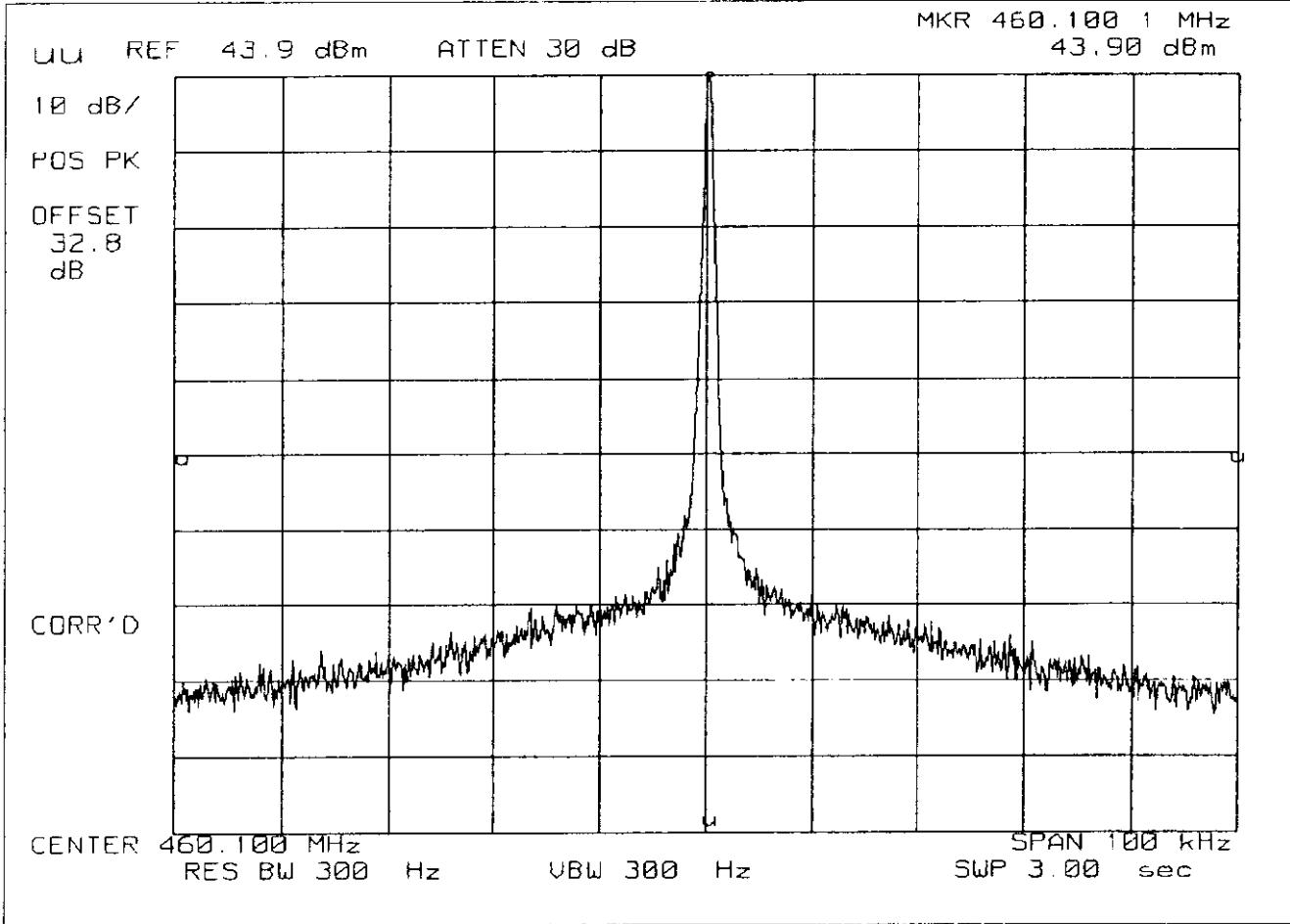

POWER: HIGH
MODULATION: VOICE: 2500 Hz SINE WAVE
MASK: D, VHF/UHF 12.5kHz BW

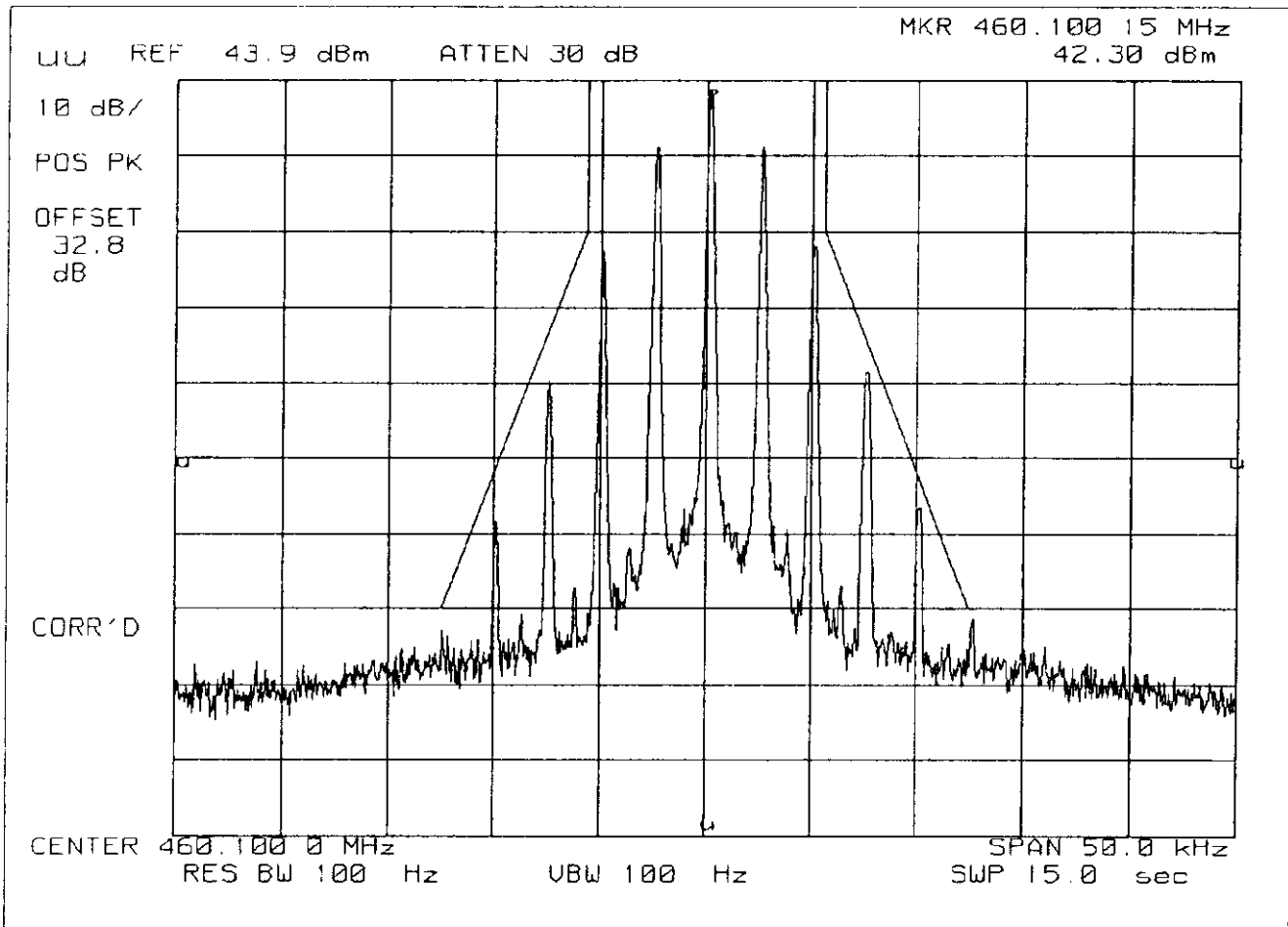

SPECTRUM ANALYZER PRESENTATION
TAIT ELECTRONICS, T856-26-0000 (TX)
1998-JUL-20, 12:04, MON

POWER: HIGH
MODULATION: VOICE: 2500 Hz SINE WAVE
MASK: B, VHF/UHF 25kHz, w/LPF

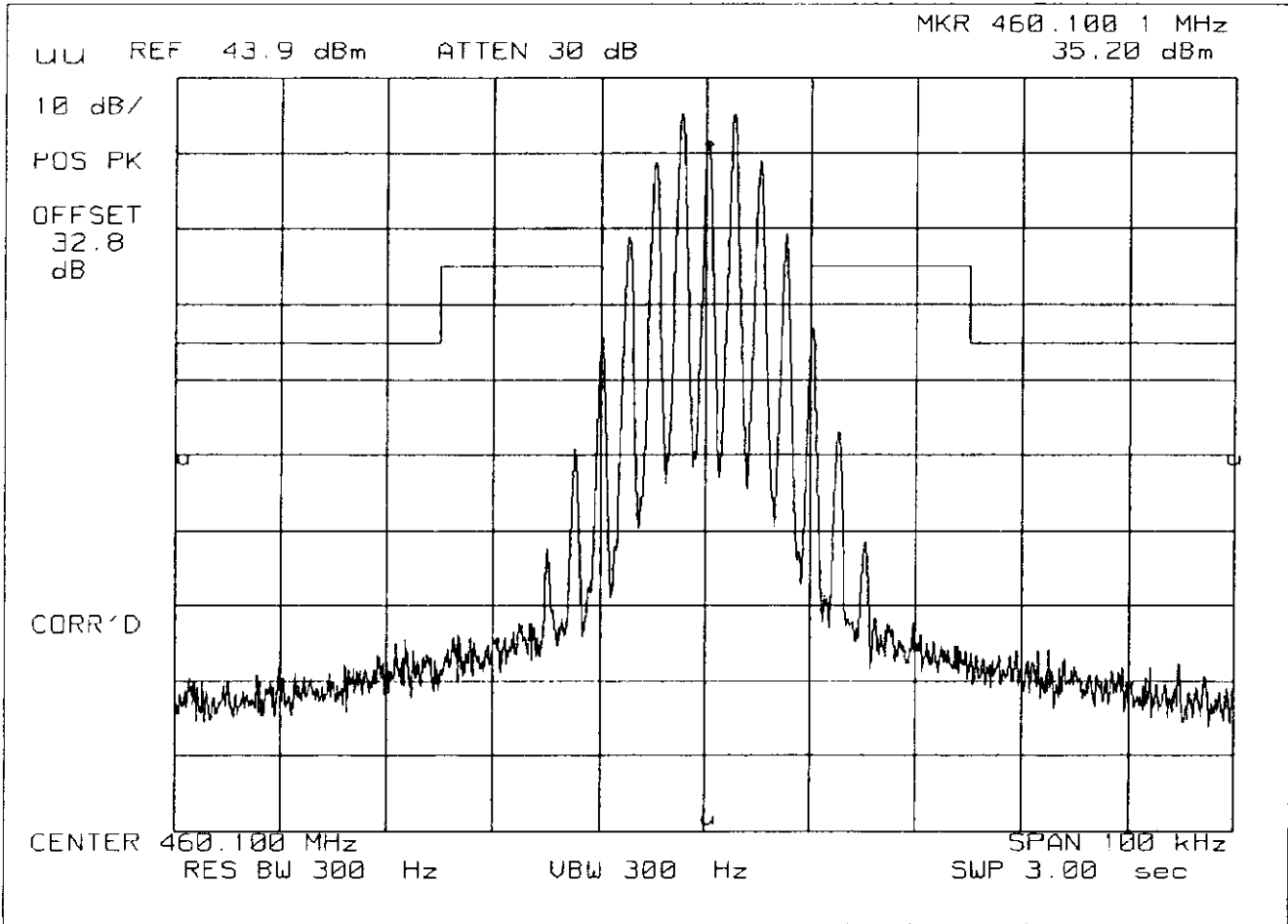

PAGE NO.

16.

CASTEL0009

NAME OF TEST:

Transient Frequency Behavior

SPECIFICATION:

FCC: 47 CFR 90.214
IC: RSS-119, Section 6.5

GUIDE:

TIA/EIA-603, Paragraph 2.2.19

TEST CONDITIONS:

S. T. & H.

TEST EQUIPMENT:

As per attached page

MEASUREMENT PROCEDURE

1. The EUT was setup as shown on the attached page, following TIA/EIA-603 steps a, b, and c as a *guide*.
2. The transmitter was turned on.
3. Sufficient attenuation was provided so that the transmitter carrier level measured at the output of the combiner was 40 dB below the maximum input level of the test receiver. This level was recorded as step f.
4. The transmitter was turned off.
5. An RF signal generator (1) modulated with a 1 kHz tone at either 25, 12.5, or 6.25 kHz deviation, and set to the same frequency as the assigned transmitter frequency, (2) was adjusted to a level -20 dB below the level recorded for step f, as measured at the output of the combiner. This level was then fixed for the remainder of the test and is recorded at step h.
6. The oscilloscope was setup using TIA/EIA-603 steps j and k as a *guide*, and to either 10 ms/div (UHF) or 5 ms/div (VHF).
7. The 30 dB attenuator was removed, the transmitter was turned on, and the level of the carrier at the output of the combiner was recorded as step l.
8. The carrier on-time as referenced in TIA/EIA-603 steps m, n, and o was captured and plotted. The carrier off-time as referenced in TIA/EIA-603 steps p, q, r, and s was captured and plotted.

LEVELS MEASURED:

<u>step f</u> , dBm	= -18.5
<u>step h</u> , dBm	= -39.7
<u>step l</u> , dBm	= 10.7

SUPERVISED BY:

MORTON FLOM, P. Eng.

TRANSIENT FREQUENCY BEHAVIOR

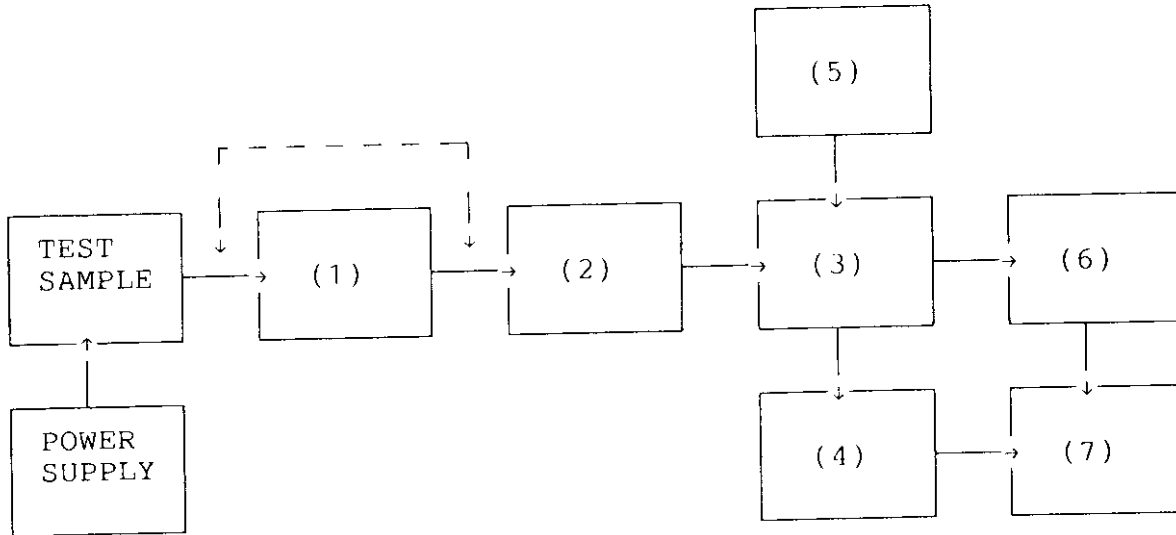

- (1) ATTENUATOR
 (NOTE: Removed after 1st step)
 30 dB x

- (2) ATTENUATOR
 30 dB
 20 dB x
 10 dB
 KAY VARIABLE

- (3) COMBINER
 4 x 25 Ω COMBINER x

- (4) CRYSTAL DETECTOR
 HP 8470B x

- (5) RF SIGNAL GENERATOR
 HP 8656A
 HP 8920A x

- (6) MODULATION ANALYZER
 HP 8901A x

- (7) SCOPE
 HP 54502A x

OSCILLOSCOPE PRESENTATION
TAIT ELECTRONICS, T856-26-0000 (TX)
1998-JUL-17, 15:01, FRI

MODULATION: Ref Gen=12.5 kHz Deviation
REMARK: CARRIER ON TIME

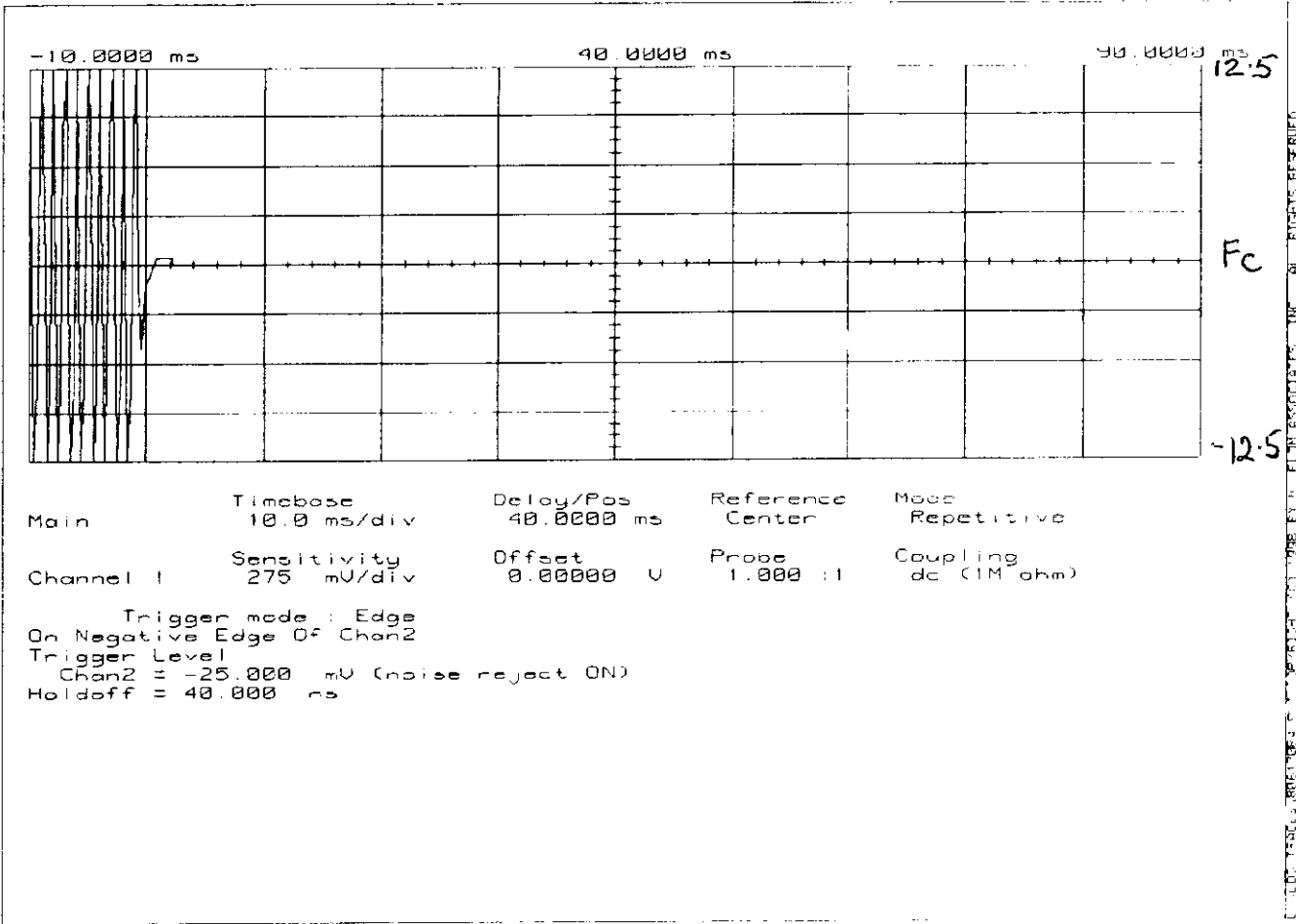

PAGE 18.2.

OSCILLOSCOPE PRESENTATION

TAIT ELECTRONICS, T856-26-0000 (TX)

1998-JUL-17, 15:03, FRI

MODULATION: Ref Gen=12.5 kHz Deviation

REMARK: CARRIER OFF TIME

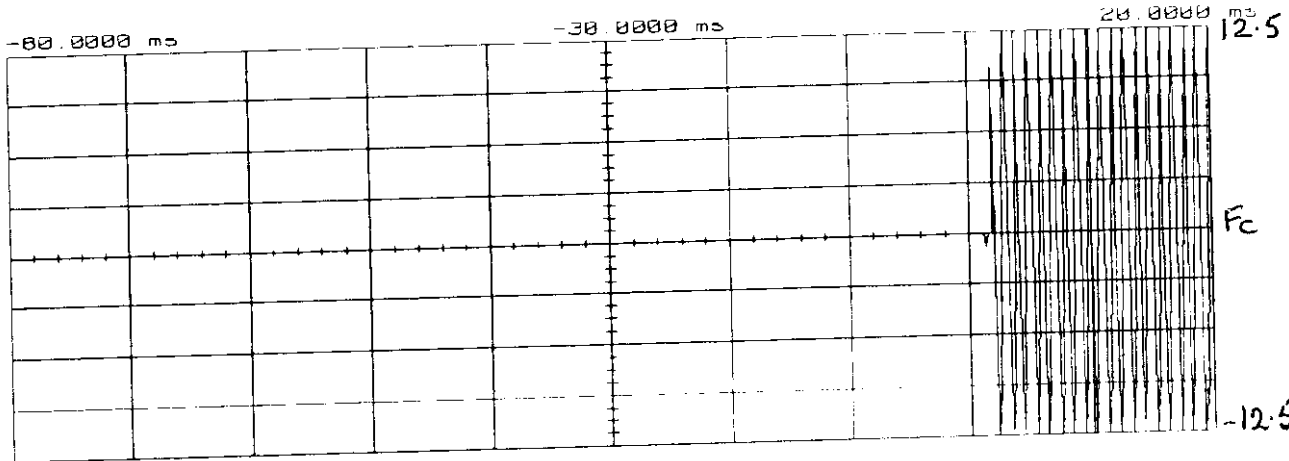

Main	Timebase 10.0 ms/div	Delay/Pos -30.0000 ms	Reference Center	Mode Repetitive
Channel 1	Sensitivity 275 mV/div	Offset 0.00000 U	Probe 1.000 :1	Coupling dc (1M ohm)

Trigger mode : Edge
 On Positive Edge Of Chan2
 Trigger Level
 Chan2 = -600.000 mV (noise reject ON)
 Holdoff = 40.000 ns

TAIT ELECTRONICS, T856-26-0000 (TX) 1998-JUL-17, 15:03, FRI

PAGE 18.3.
 OSCILLOSCOPE PRESENTATION
 TAIT ELECTRONICS, T856-26-0000 (TX)
 1998-JUL-17, 14:59, FRI

MODULATION: Ref Gen=25 kHz Deviation
 REMARK: CARRIER ON TIME

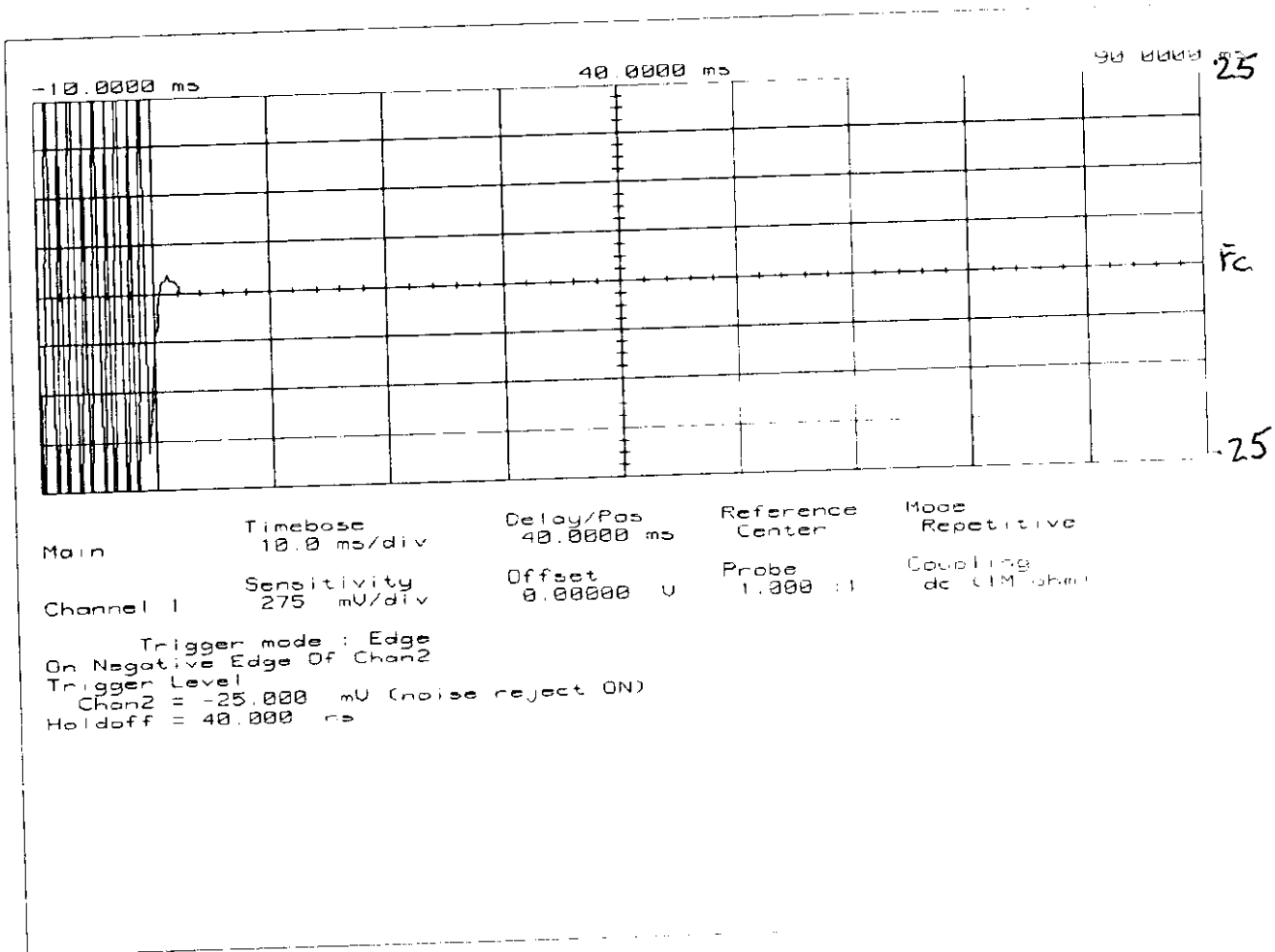

Main	Timebase 10.0 ms/div	Delay/Pos 40.0000 ms	Reference Center	Mode Repetitive
Channel 1	Sensitivity 275 mV/div	Offset 0.00000 V	Probe 1.000 :1	Coupling dc (1M Ohm)

Trigger mode : Edge
 On Negative Edge Of Chan2
 Trigger Level
 Chan2 = -25.000 mV (noise reject ON)
 Holdoff = 40.000 ns

ALL RIGHTS RESERVED
 TAIT ELECTRONICS, T856-26-0000 (TX)

OSCILLOSCOPE PRESENTATION

TAIT ELECTRONICS, T856-26-0000 (TX)

1998-JUL-17, 15:00, FRI

MODULATION: Ref Gen=25 kHz Deviation
REMARK: CARRIER OFF TIME

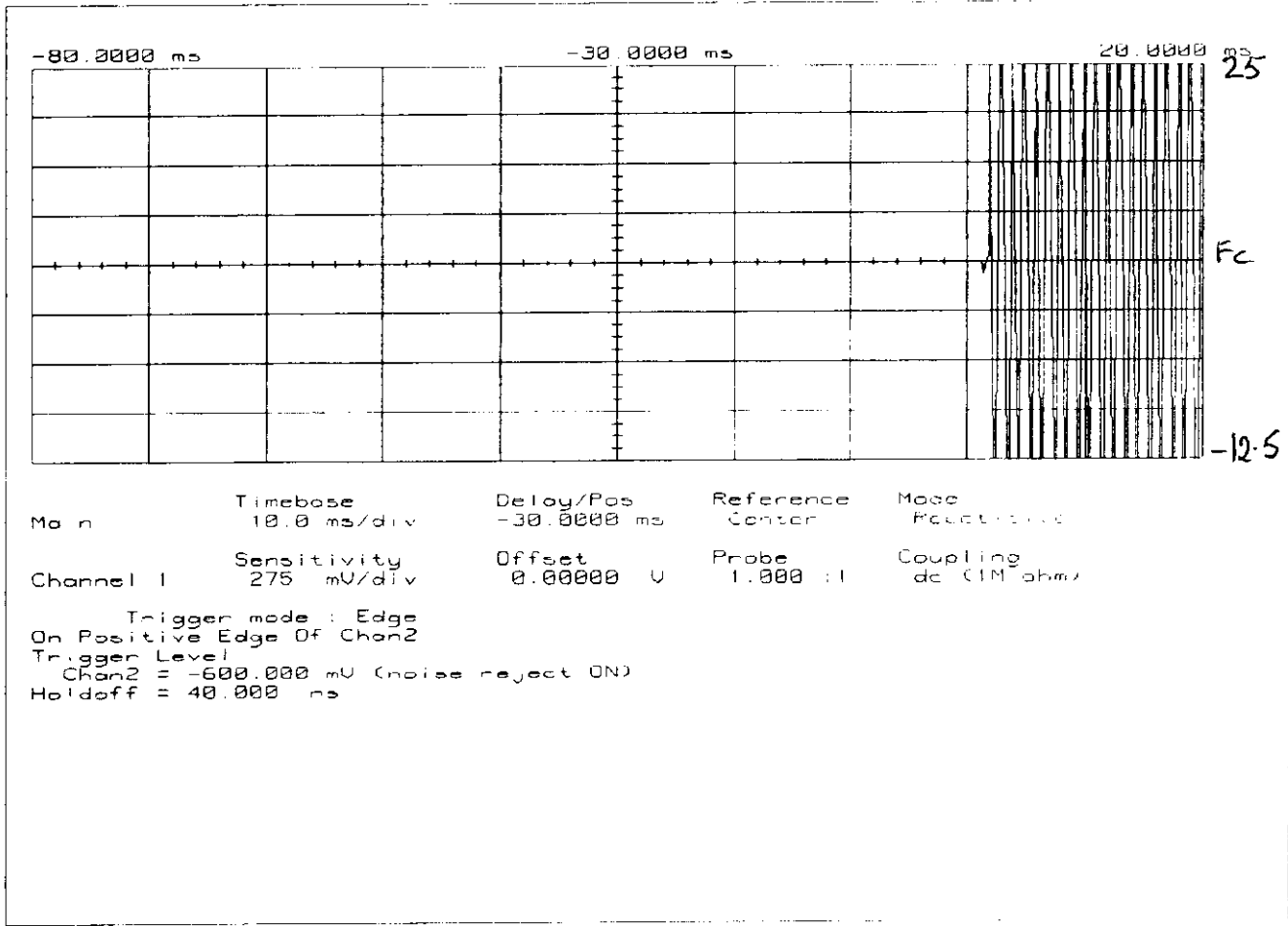

TAIT ELECTRONICS, T856-26-0000 (TX) 1998-JUL-17, 15:00, FRI

PAGE NO.

19.

CASTEL0009

NAME OF TEST:

Audio Low Pass Filter (Voice Input)

SPECIFICATION:

FCC: 47 CFR 2.987(a)
IC: RSS-119, Section 6.6

GUIDE:

TIA/EIA-603, Paragraph 2.2.15

TEST CONDITIONS:

S. T. & H.

TEST EQUIPMENT:

As per attached page

MEASUREMENT PROCEDURE

1. The EUT and test equipment were set up such that the audio input was connected at the input to the modulation limiter, and the modulated stage.
2. The audio output was connected at the output to the modulated stage.
3. MEASUREMENT RESULTS: ATTACHED

TRANSMITTER TEST SET-UP

- TEST A. MODULATION CAPABILITY/DISTORTION
- TEST B. AUDIO FREQUENCY RESPONSE
- TEST C. HUM AND NOISE LEVEL
- TEST D. RESPONSE OF LOW PASS FILTER
- TEST E. MODULATION LIMITING

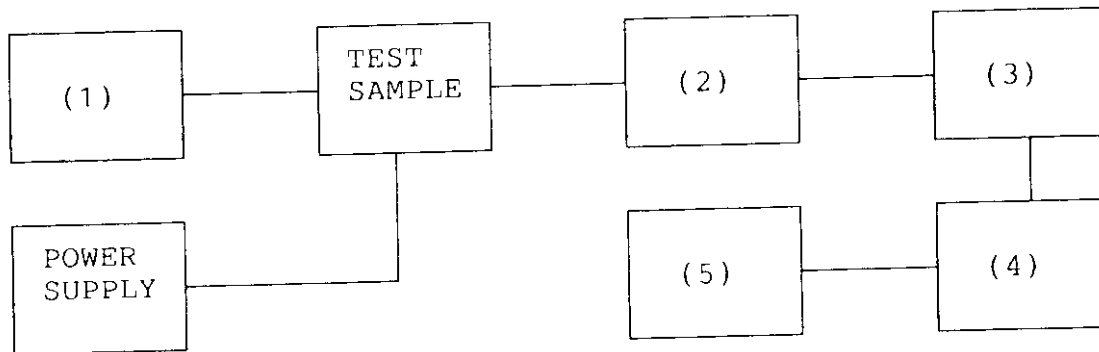

(1) AUDIO OSCILLATOR/GENERATOR

HP 204D	---
HP 8903A	---
HP 3312A	<u>x</u>
_____	<u>x</u>

(2) COAXIAL ATTENUATOR

NARDA 766-10	---
SIERRA 661A-30	<u>x</u>
BIRD 8329 (30 dB)	---
_____	---

(3) MODULATION ANALYZER

HP 8901A	<u>x</u>
_____	---

(4) AUDIO ANALYZER

HP 8903A	<u>x</u>
_____	---

(5) SCOPE

HP 1741A	---
HP 181T	---
TEK 935	---
_____	---

PAGE 21.
FREQUENCY RESPONSE OF AUDIO LOW PASS FILTER
TAIT ELECTRONICS, T856-26-0000 (TX)
20 JUL 1998, 10:09

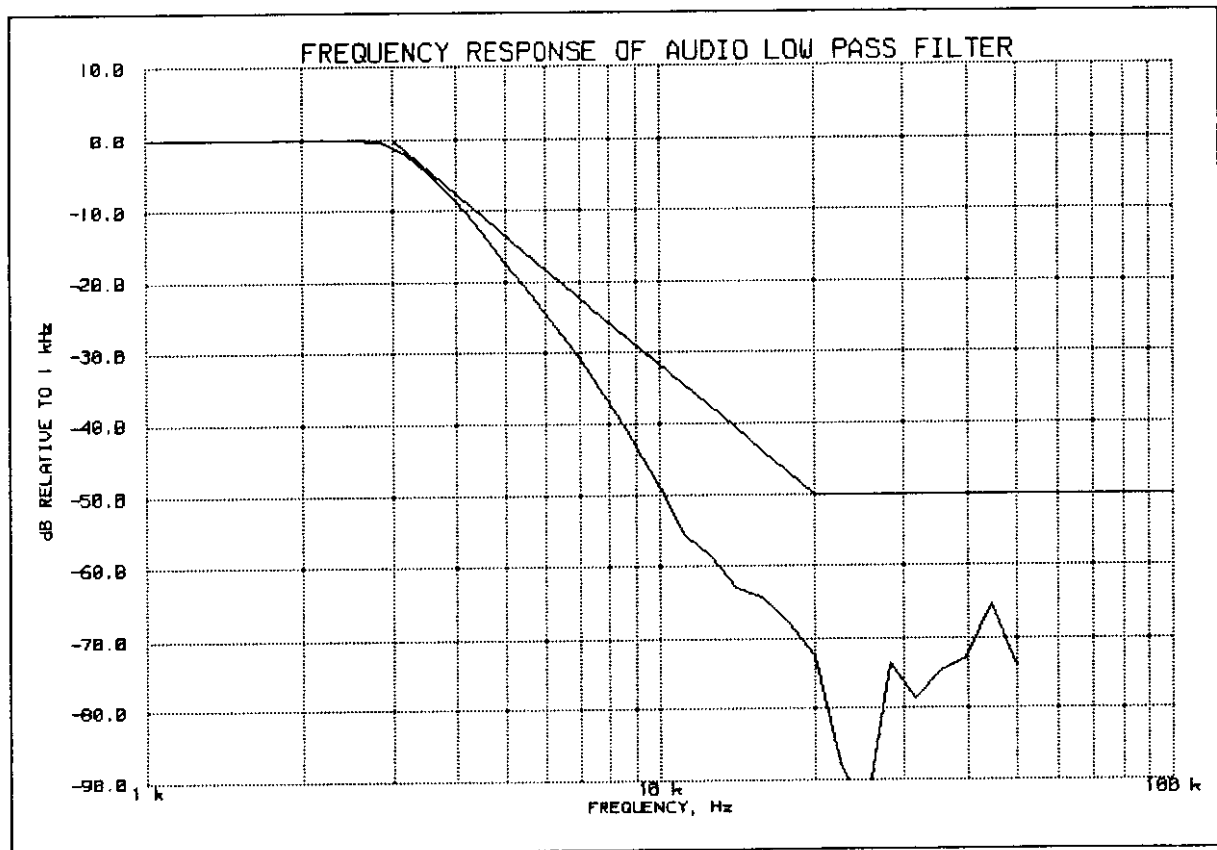

PEAK AUDIO FREQUENCY, Hz: 2510

Morton Flom P. Eng.

SUPERVISED BY:

MORTON FLOM, P. Eng.

PAGE NO.

22.

CASTEL0009

NAME OF TEST:

Audio Frequency Response

SPECIFICATION:

FCC: 47 CFR 2.987(a)
IC: N/A

GUIDE:

TIA/EIA-603, Section 2.2.6

TEST CONDITIONS:

S. T. & H.

TEST EQUIPMENT:

As per previous page

MEASUREMENT PROCEDURE

1. The EUT and test equipment were set up as shown on the following page.
2. The audio signal generator was connected to the audio input circuit/microphone of the EUT.
3. The audio signal input was adjusted to obtain 20% modulation at 1 kHz, and this point was taken as the 0 dB reference level.
4. With input levels held constant and below limiting at all frequencies, the audio signal generator was varied from 100 Hz to 50 kHz.
5. The response in dB relative to 1 kHz was then measured, using the HP 8901A Modulation Analyzer.
6. MEASUREMENT RESULTS: ATTACHED

TRANSMITTER AUDIO FREQUENCY RESPONSE
TAIT ELECTRONICS, T856-26-0000 (TX)
20 JUL 1998, 10:03

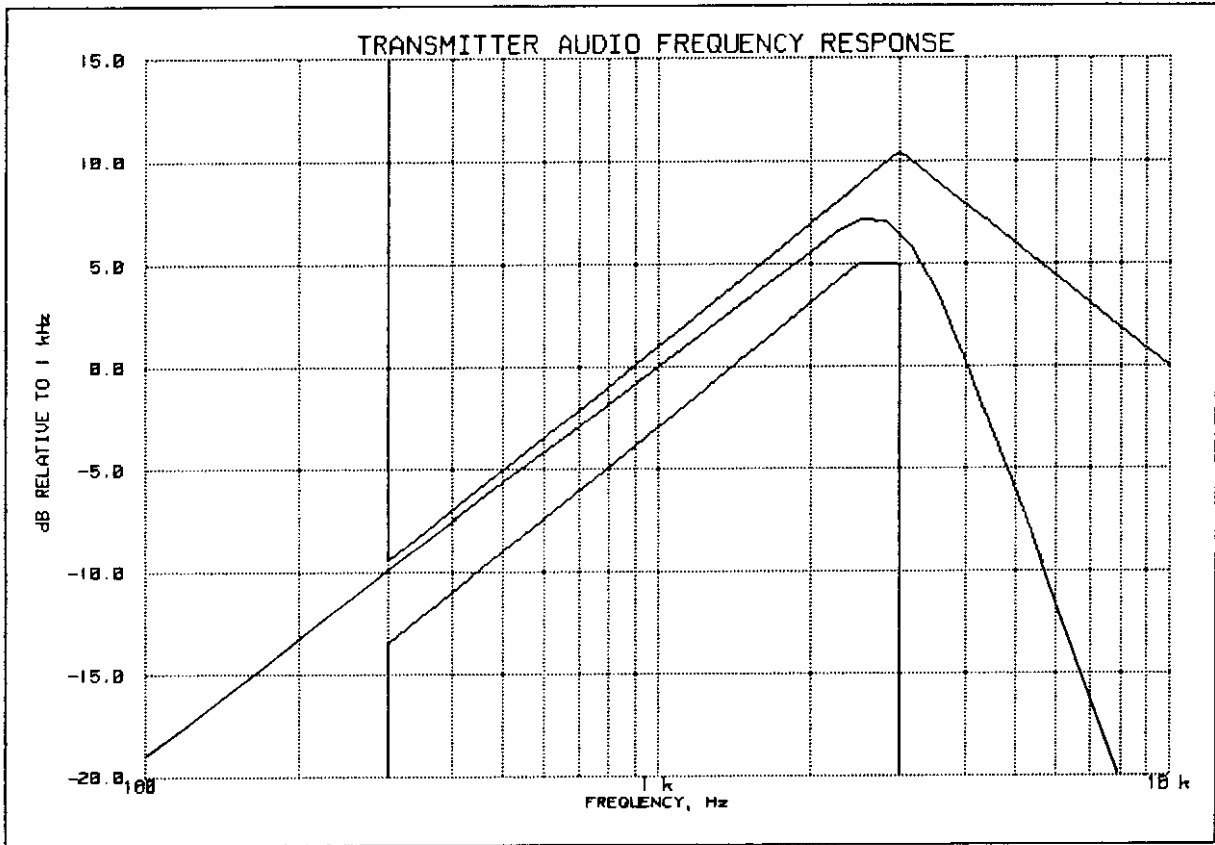

PEAK AUDIO FREQUENCY, Hz: 2510

TABLE VALUES:

FREQUENCY, Hz	LEVEL, dB	FREQUENCY, Hz	LEVEL, dB	FREQUENCY, Hz	LEVEL, dB
300	-9.7	30000	-17.7		
20000	-17.6	50000	-17.7		

Morton Flom P. Eng.

SUPERVISED BY:

MORTON FLOM, P. Eng.

PAGE NO.

24.

CASTEL0009

NAME OF TEST:

Modulation Limiting

SPECIFICATION:

IC: RSS-119, Section 6.6
FCC: 47 CFR 2.987(b)

GUIDE:

TIA/EIA-603, Paragraph 2.2.3

TEST CONDITIONS:

S. T. & H.

TEST EQUIPMENT:

As per attached page

MEASUREMENT PROCEDURE

1. The signal generator was connected to the input of the EUT as for "Frequency Response of the Modulating Circuit."
2. The modulation response was measured for each of three frequencies (one of which was the frequency of maximum response), and the input voltage was varied and was observed on an HP 8901A Modulation Analyzer.
3. The input level was varied from 30% modulation (± 1.5 kHz deviation) to at least 20 dB higher than the saturation point.
4. Measurements were performed for both negative and positive modulation and the respective results were recorded.
5. MEASUREMENT RESULTS: ATTACHED

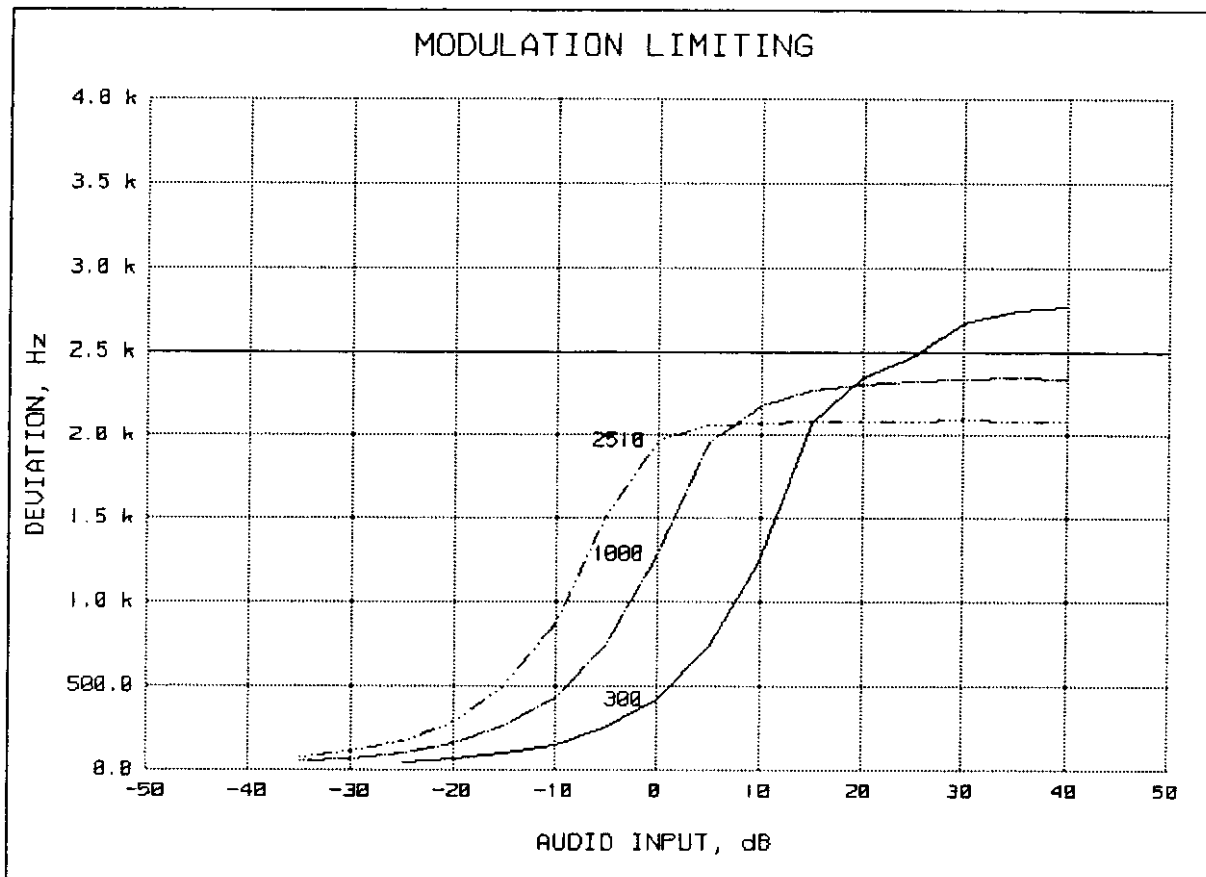

REFERENCE DEVIATION, kHz = 1.25

REFERENCE MODULATION, Hz = 1000

PEAKS = POSITIVE

AUDIO AMPLITUDE, mV = 35.82

Morton Flom P. Eng.

SUPERVISED BY:

MORTON FLOM, P. Eng.

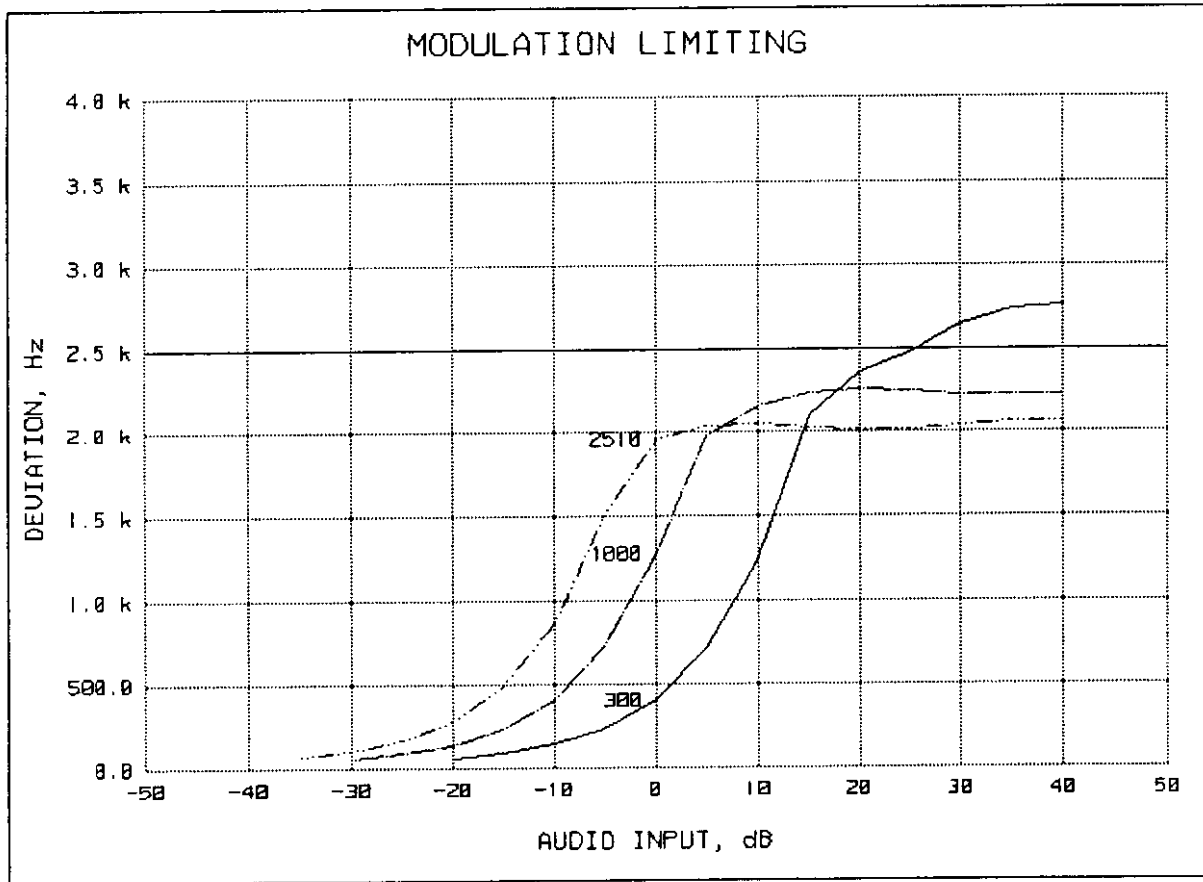

REFERENCE DEVIATION, kHz = 1.25
 REFERENCE MODULATION, Hz = 1000
 PEAKS = NEGATIVE
 AUDIO AMPLITUDE, mV = 35.82

Morton Flom P. Eng.

SUPERVISED BY:

MORTON FLOM, P. Eng.

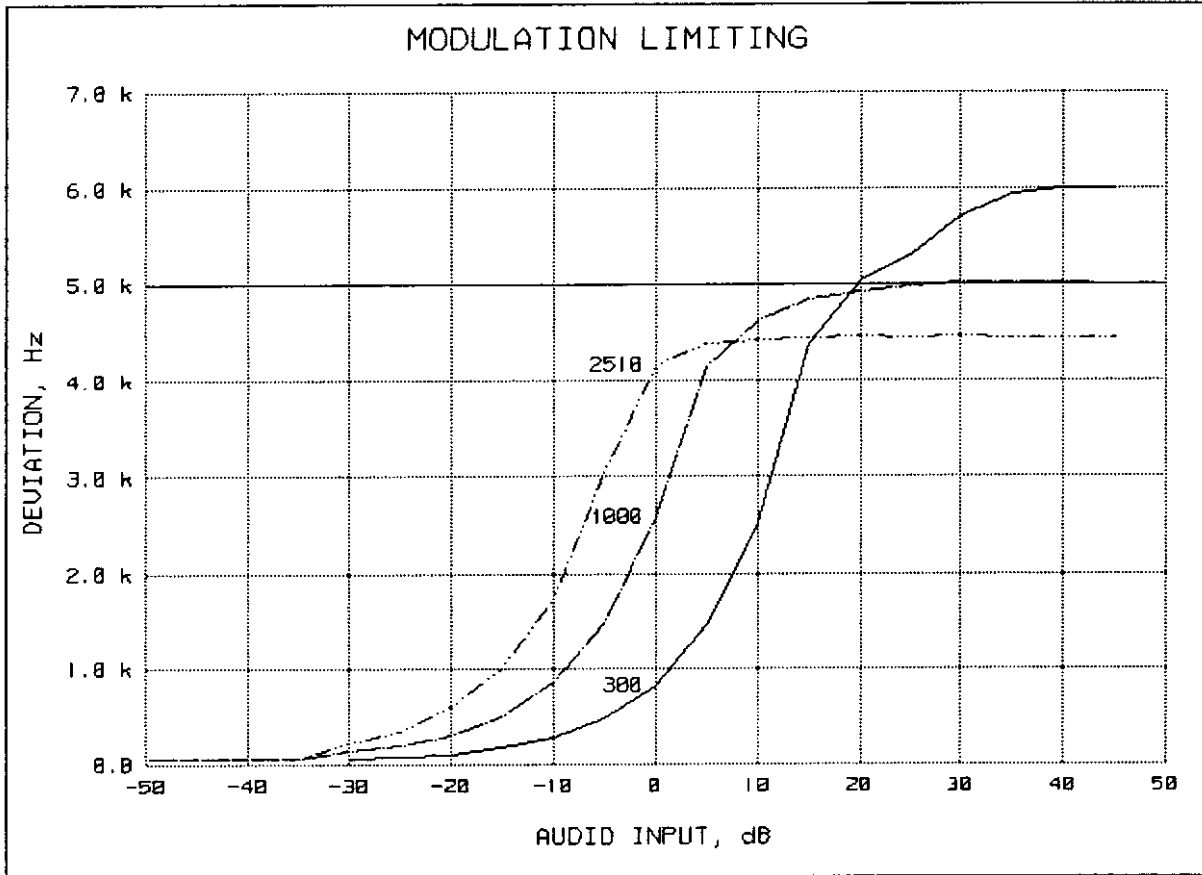

REFERENCE DEVIATION, kHz = 2.5
REFERENCE MODULATION, Hz = 1000
PEAKS = POSITIVE
AUDIO AMPLITUDE, mV = 33.43

Morton Flom P. Eng.

SUPERVISED BY:

MORTON FLOM, P. Eng.

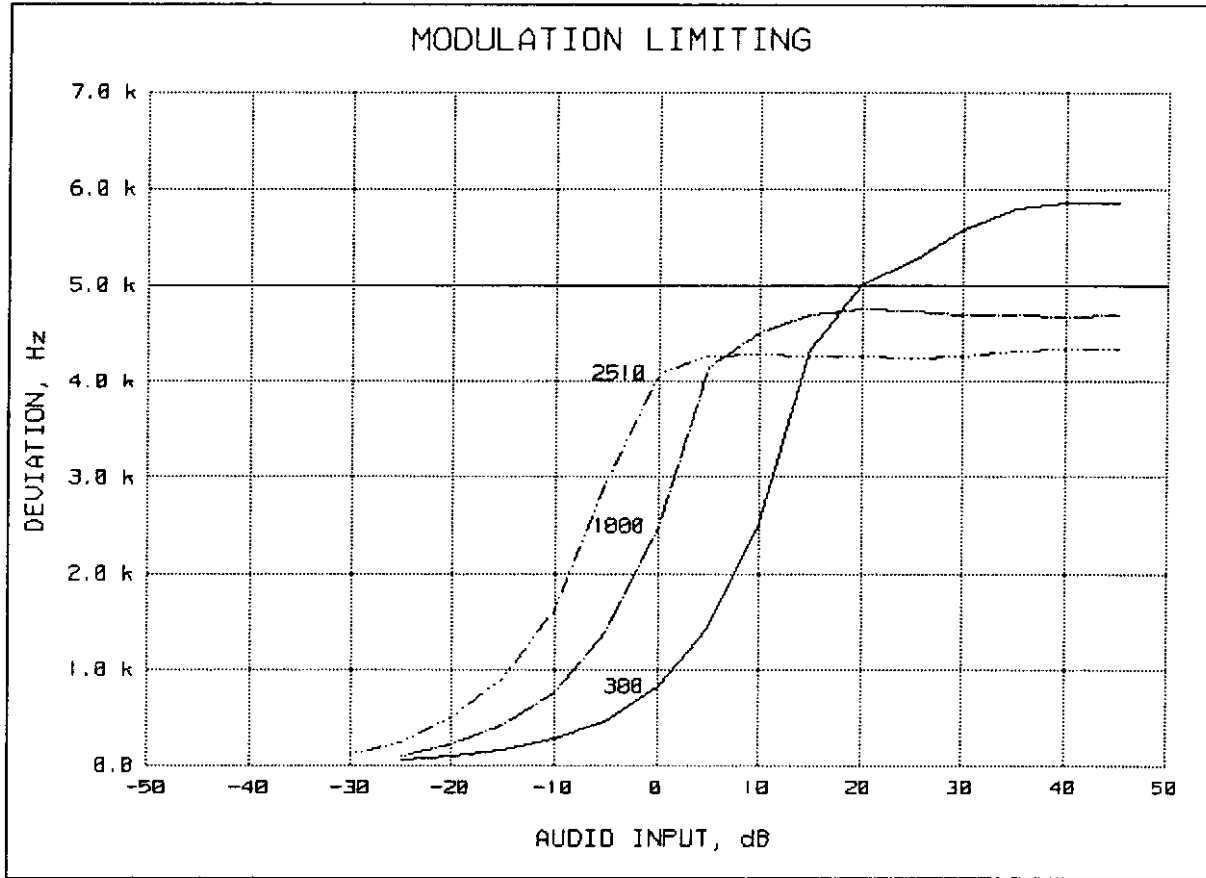

REFERENCE DEVIATION, kHz = 2.5
 REFERENCE MODULATION, Hz = 1000
 PEAKS = NEGATIVE
 AUDIO AMPLITUDE, mV = 33.43

Morton Flom P. Eng.

SUPERVISED BY:

MORTON FLOM, P. Eng.

PAGE NO.

26.

CASTEL0009

NAME OF TEST:

Frequency Stability (Temperature Variation)

SPECIFICATION:

FCC: 47 CFR 2.995(a)(1)
IC: RSS-119, Section 7.0

GUIDE:

TIA/EIA-602, Section 2.2.2

TEST CONDITIONS:

As indicated

TEST EQUIPMENT:

As per attached page

MEASUREMENT PROCEDURE

1. The EUT and test equipment were set up as shown on the following page.
2. With all power removed, the temperature was decreased to -30°C and permitted to stabilize for three hours. Power was applied and the maximum change in frequency was noted within one minute.
3. With power OFF, the temperature was raised in 10°C steps. The sample was permitted to stabilize at each step for at least one-half hour. Power was applied and the maximum frequency change was noted within one minute.
4. The temperature tests were performed for the worst case.
5. MEASUREMENT RESULTS: ATTACHED

TRANSMITTER TEST SET-UP

- TEST A. OPERATIONAL STABILITY
- TEST B. CARRIER FREQUENCY STABILITY
- TEST C. OPERATIONAL PERFORMANCE STABILITY
- TEST D. HUMIDITY
- TEST E. VIBRATION
- TEST F. ENVIRONMENTAL TEMPERATURE
- TEST G. FREQUENCY STABILITY: TEMPERATURE VARIATION
- TEST H. FREQUENCY STABILITY: VOLTAGE VARIATION

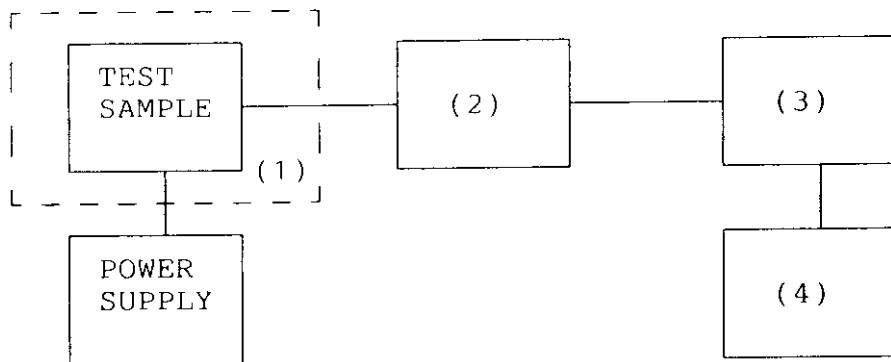

(1) TEMPERATURE, HUMIDITY, VIBRATION

TENNEY TEMPERATURE CHAMBER	<u> x </u>
WEBER HUMIDITY CHAMBER	<u> </u>
L.A.B. RVH 18-100	<u> </u>

(2) COAXIAL ATTENUATOR

NARDA 766-10	<u> </u>
SIERRA 661A-30	<u> x </u>
BIRD 8329 (30 dB)	<u> x </u>

(3) R.F. POWER

HP 435A POWER METER	<u> </u>
HP 436A POWER METER	<u> x </u>
HP 8901A POWER MODE	<u> x </u>

(4) FREQUENCY COUNTER

HP 5383A	<u> </u>
HP 5334B	<u> x </u>
HP 8901A	<u> x </u>

TRANSMITTER FREQUENCY STABILITY
TAIT ELECTRONICS, T856-26-0000 (TX)

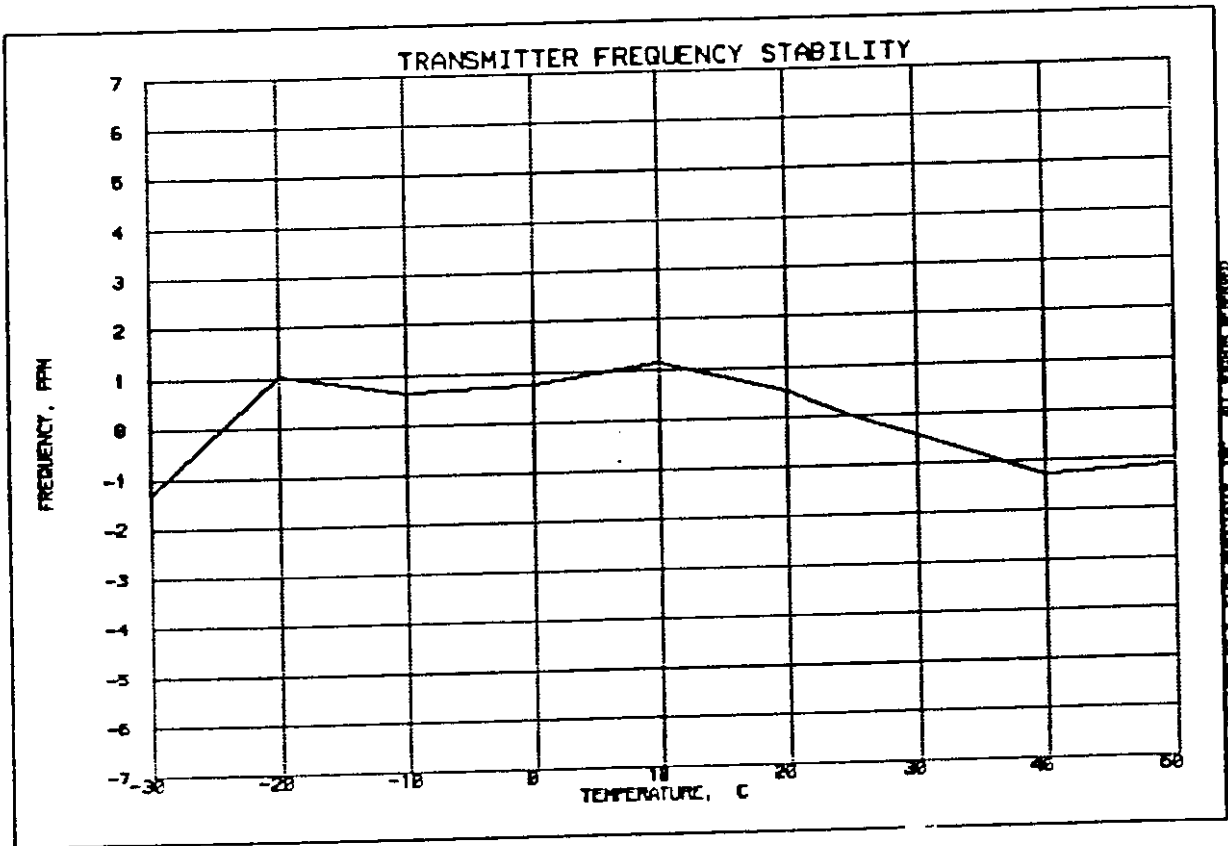

FREQUENCY OF CARRIER, MHz = 460.1

LIMIT, ppm = ±1.5

LIMIT, Hz = 690

Morton Flom P. Eng.

MORTON FLOM, P. Eng.

SUPERVISED BY:

PAGE NO. 29. CASTEL0009

NAME OF TEST: Frequency Stability (Voltage Variation)

SPECIFICATION: FCC: 47 CFR 2.995 (b)(1)
IC: RSS-119, Section 7.0

GUIDE: TIA/EIA-602, Section 2.2.2

TEST CONDITIONS: As indicated

TEST EQUIPMENT: As per attached page

MEASUREMENT PROCEDURE

1. The EUT was placed in a temperature chamber at 25±5°C and connected as for "Frequency Stability - Temperature Variation" test.
2. The power supply voltage to the EUT was varied from 85% to 115% of the nominal value measured at the input to the EUT.
3. The variation in frequency was measured for the worst case.

MEASUREMENT RESULTS

LIMIT, ppm = 1.5
LIMIT, Hz = 690

STV, %	Vdc	<u>CHANGE IN FREQUENCY, Hz</u>	
85	102	460.100010	10
100	120	460.100000	0
115	138	460.100000	0

SUPERVISED BY:

M. F. Eng
MORTON FLOM, P. Eng.

PAGE NO.

30.

CASTEL0009

NAME OF TEST:

Necessary Bandwidth and Emission Bandwidth

PARAGRAPH:

47 CFR 2.202(g)

MODULATION = 16K0F3E

NECESSARY BANDWIDTH CALCULATION:

MAXIMUM MODULATION (M), kHz = 3
MAXIMUM DEVIATION (D), kHz = 5
CONSTANT FACTOR (K) = 1
NECESSARY BANDWIDTH (B_N), kHz = $(2 \times M) + (2 \times D \times K)$
= 16.0

MODULATION = 11K0F3E

NECESSARY BANDWIDTH CALCULATION:

MAXIMUM MODULATION (M), kHz = 3
MAXIMUM DEVIATION (D), kHz = 2.5
CONSTANT FACTOR (K) = 1
NECESSARY BANDWIDTH (B_N), kHz = $(2 \times M) + (2 \times D \times K)$
= 11.0

SUPERVISED BY:

MORTON FLOM, P. Eng.

TESTIMONIAL
AND
STATEMENT OF CERTIFICATION

CASTEL0009

THIS IS TO CERTIFY:

1. THAT the application was prepared either by, or under the direct supervision of, the undersigned.
2. THAT the technical data supplied with the application was taken under my direction and supervision.
3. THAT the data was obtained on representative units, randomly selected.
4. THAT, to the best of my knowledge and belief, the facts set forth in the application and accompanying technical data are true and correct.

CERTIFYING ENGINEER:

MORTON FLOM, P. Eng.

STATEMENT OF QUALIFICATIONS

EDUCATION:

1. B. ENG. in ENGINEERING PHYSICS, 1949, McGill University, Montreal, Canada.
2. Post Graduate Studies, McGill University & Sir George Williams University, Montreal.

PROFESSIONAL AFFILIATIONS:

1. ARIZONA SOCIETY OF PROFESSIONAL ENGINEERS (NSPE), #026 031 821.
2. ORDER OF ENGINEERS (QUEBEC) 1949. #4534.
3. ASSOCIATION OF PROFESSIONAL ENGINEERS, GEOPHYSICISTS & GEOLOGISTS OF ALBERTA #5916.
4. REGISTERED ENGINEERING CONSULTANT - GOVERNMENT OF CANADA, DEPARTMENT OF COMMUNICATIONS. Radio Equipment Approvals.
5. IEEE, Lifetime Member No. 0417204 (member since 1947).

EXPERIENCE:

1. Research/Development/Senior Project Engineer, R.C.A. LIMITED (4 years).
2. Owner/Chief Engineer of Electronics. Design/Manufacturing & Cable TV Companies (10 years).
3. CONSULTING ENGINEER (over 25 years).

MORTON FLOM, P. Eng.

TEST INSTRUMENTATION LIST

All equipment calibrated within last 90 days

ADAPTER

HP X281 (Coaxial waveguide); HP S281; HP 85659 (Quasi peak)

AMPLIFIER

Pre-amp. HP 10885A (2-1300 MHz); HP 8447D, HP 8447E, HP 8449A

ANTENNA See end

ATTENUATOR

Kay 432D; Power, Sierra 661A-30; Narda 76610; Narda 4779-3, -6, -10 dB

AUDIO OSCILLATOR

HP 204D; AIEC DTC-1; Motorola S-1333B; HP 3312A; HP 8903A

BATTERY

Sears Diehard, Stock #4341

CAMERA

Oscilloscope, Tektronix CSA; Polaroid Impulse AF; Kodak DC-50

CAPACITOR

Feed-Thru, 10 μ F, Solar 6512-106R; Solar 7525-1

CLOSE FIELD PROBE

HP 11940A, 11941A, HP 11945A

COMPUTER

HP 332; HP Vectra 486/25VL; Various PC Compatibles

CONVERTOR, Down

HP 117 10B

COUPLER

Narda 1080, Waveguide; HP S750E (Cross guide); Waveline 274/40; Solar 7415-3; Solar 7835-891 & -896

CURRENT PROBE

Solar 6741-1

DETECTOR

HP 8470B

DIGITAL MULTIMETER

HP 3476A w/H.F. Probe; Fluke 8030A-01; HP 3478A

DISTORTION ANALYZER

HP 334A; HP 8903A

ELECTRONIC COUNTER

HP 5383A; HP 5334B

FILTER

Cirqtel FHT/7-50-57/50-1A/1B (HP); Jerrold TLB-1; THB-1, Piezo 5064; Eagle TNF-I Series, Krohn-Hite 3202; Phelps-Dodge #PD-495-8; Newtonone #PD6000 Line Protector; 870-890 MHz (Lab Design); 900 MHz (Lab Design); Solar High-Pass s/n 882029

FREQ. DEV. METER

HP 8901A

FREQ. DOUBLER

HP 11721A

FREQUENCY METER

HP 537A; HP 536A

GENERATOR

Solar 6550-1 (power sweep); HP 8640B, GAW 1012, HP 8656A (signal); Solar 8282-1 (spike)

HUMIDITY CHAMBER

Ember Co FW30; Bowser 0

LIMITER, R.F.

HP 11867A; HP 11693A; HP 10509A

LISN

Singer 91221-1; Ailtech 94641-1 (50 μ H)

LOAD, POWER

Telewave TLW-25; Bird 8329

MILLIAMETER

HP 428B

MIXER

HP 10514A; Mini-Circuits TAK-1H

OPEN FIELD SITE

As filed with FCC & IC and kept up-dated.

TURNTABLES:

Up to 2000# capacity

GROUND SCREEN:

Complies with docket 80-284

ANTENNA MAST:

Complies as above

OSCILLOSCOPE

HP 1741A; HP 181T; Tektronix T935; HP 54502A

PHANTOM

M.F.A. Labs Left and Right human head

PLOTTER

HP 7470; HP7475A

POWER METER

AF GR 1840A; HP 435A with 8481A & 8482H Power Sensors; HP 436A; HP 8901A

POWER SUPPLY

HP 6286A; Heathkit 1P 2711; 1P 5220; Honda EM400 (portable gas gen.); HP 6012

PRINTER

Brother HL-8; Brother HL-10V; HP DeskJet 640C

R. F. PRESELECTOR

HP 85685A

RADIATION METER

Narda 8717 w/8010 Amp, 8021B and 8760 probes

RESISTOR, PRECISION

Solar 7144-1.0, 7144-10.0; Solar 8525-1

SCALE

Weigh-Tronix 3632T-50

SCANNER

HP 9190A Scanjet

SCREEN ROOM

Lindgren 22-2/2-0

SIGNAL LEVEL METER

Jerrold 704B

SIGNAL SAMPLER

R. F. Bird 4273-030, 4275-030

SINAD/VOLTMETER

Helper Sinadder

SPECTRUM ANALYZER

HP 8558B, 8557; HP 8563E; HP 853A; HP 8566B/8568B

TEMPERATURE CHAMBER

Tenney, Jr

TEMPERATURE PROBE

Fluke 80T-150C

TERMINATION

Narda 320B Waveguide, Waveline #281

TEST SET

Semi-Automatic; HP 8953A; HP 8954A Interface; Computer / Controller; P.S. Programmer; HP 59501A; RF Communications; HP 8920A

TRANSFORMERS

Audio Isolation: Solar 6220-1A; Impedance: HP 11694A; Isolation: Solar 7032-1; Matching: Solar 7033-1

TRANSMISSION & NOISE

MEASURING SET

HP 3555B

VIBRATION CHAMBER

Unholtz-Dickie T 500; Unholtz-Dickie T 4000

VOLTMETER

HP 410C; HP 3478A

WATTMETER

Bird 43, Sierra 174A-2

ANTENNAS

30 - 50 Hz

Emco 7603 M-Field; Emco 7604 M-Field

20 - 200 MHz

Apriel Biconical Model AAB20200

20 - 300 MHz

Emco Biconical H-Field

25 - 1000 MHz

Singer DM-105A; EMCO 3121C

200 - 1000 MHz

Apriel Log Periodic, Model AALP 2001

10 kHz - 30 MHz

Emco 3107B, E-Field; Emco 3101B/1, Rod E-Field

10 kHz - 32 MHz

Singer 94593-1 (Loop)

150 kHz - 32 MHz

Singer 92197-1 (41")

150 kHz - 32 MHz

Singer 93049-1 (9')

1 - 10 GHz

Singer 90794-A Discone

1 - 18 GHz

Horn: Apriel Model AAH-118

18 - 40 GHz

Emco 3116, Horn

40 - 60 GHz

Horn: HP 11970U, HP 11971U,

HP 11975A (Lo Drive

Amplifier)

50 - 75 GHz

Mixer, HP 11970V, HP 11971V

75 - 110 GHz

Mixer, HP 11970W