

Laboratory Test Report

For the
TBAC0 Base Station Transceiver

Tested In accordance with

FCC 47 CFR Parts 80 and 90T

Report Revision: 1
Issue Date: 14-August-2006
FCC ID: CASTBA8C0

PREPARED BY: Marcus Ludwig _____
Test Technician

CHECKED & APPROVED BY: S A Crompton _____
Laboratory Manager



All tests reported herein have been performed in accordance with the laboratory's scope of accreditation

This document must not be reproduced except in full, without the written permission of the Compliance Laboratory Manager.

TABLE OF CONTENTS

REVISION HISTORY.....	3
INTRODUCTION.....	3
REPORT PREPARED FOR.....	3
STATEMENT OF COMPLIANCE.....	4
DESCRIPTION OF SAMPLE.....	4
TEST CONDITIONS.....	4
NECESSARY BANDWIDTH AND EMISSION DESIGNATORS.....	5
TEST RESULTS.....	6
TRANSMITTER OUTPUT POWER (CONDUCTED).....	6
TRANSMITTER AUDIO FREQUENCY RESPONSE - PRE-EMPHASIS.....	8
SIDEBAND SPECTRUM.....	16
SPURIOUS EMISSIONS (CONDUCTED).....	41
SPURIOUS EMISSIONS (RADIATED).....	44
TRANSMITTER FREQUENCY STABILITY (TEMPERATURE).....	47
TRANSMITTER FREQUENCY STABILITY (VOLTAGE).....	49
TEST EQUIPMENT USED.....	50
ANNEX A.....	51
TEST SETUP DETAILS.....	51

REVISION HISTORY

Date	Revision	Comments
14-August-2006	1	Initial test report

INTRODUCTION

Type approval testing of the Tait base station equipment type TBAC0.
This test report details performance of the product.

Type approval testing in accordance with: FCC CFR 47 Part 80 and 90T

The 50 W AC and DC versions of type TBAC0 equipment is to be assigned
the FCC ID: CASTBA8C0.

REPORT PREPARED FOR

Tait Electronics Ltd
PO Box 1645
558 Wairakei Rd
Christchurch
New Zealand

STATEMENT OF COMPLIANCE

The TBAC0 Base Station transceiver as tested in this report was found to conform to the following standards:

FCC CFR 47 Parts 80 & 90T

DESCRIPTION OF SAMPLE

Equipment: Base Station Transceiver. 193MHz to 225MHz

Type: TBAC0

Details:

Component:	Type:	Model:	S/N:
Subrack	TBAC0	TBA2321-A000	18001272
Associated User Interface		XBA2020	18004403
TB8100 Reciter 1 (Voice/FFSK)	TBA4C2	TBA40C2-0B00	18009809
50W 120V AC Power Amplifier	TBA8C0	TBA80C0-0000	18005083
50W 12V DC Power Amplifier	TBA8C0	TBA81C0-0000	18005084
Power Management Unit (AC unit only)	TBA3A0	TBA30A0-0000	18004653

TEST CONDITIONS

All testing was performed at the following conditions.

Ambient Temperature	15°C to 30°C
Relative Humidity	20% to 75%
Standard Test Voltage	120 Vac (PMU) / 13.8V DC (12V PA)

NECESSARY BANDWIDTH AND EMISSION DESIGNATORS

SPECIFICATION: FCC 47 CFR 2.202

The Necessary Bandwidth is the minimum value of the occupied bandwidth sufficient to ensure the transmission of information at the rate and with the quality required for the system employed.

This is calculated using the following formula.

$$B_n = 2M + 2DK$$

Where: B_n = Necessary Bandwidth

M = Maximum modulation frequency

For Data transmission

$$M = B/2$$

Where: B = Modulation rate in Baud

D = Peak deviation

K = Constant

For Analogue transmission this is 1

For Data transmission this is typically 1.2

1. Analogue Voice 12.5kHz Bandwidth

Necessary bandwidth

Emission Designator

$$M = 3\text{kHz}$$

$$D = 2.5\text{kHz}$$

11k0F3E

F3E represents a FM voice transmission

$$\begin{aligned} B_n &= 6 + 5 \times 1 \\ &= 11\text{kHz} \end{aligned}$$

2. Analogue Voice 25kHz Bandwidth

Necessary bandwidth

Emission Designator

$$M = 3\text{kHz}$$

$$D = 5\text{kHz}$$

16k0F3E

F3E represents a FM voice transmission

$$\begin{aligned} B_n &= 6 + 10 \times 1 \\ &= 16\text{kHz} \end{aligned}$$

3. Fast Frequency Shift Keying (FFSK) 12.5kHz Bandwidth

Necessary bandwidth

Emission Designator

$$M = 1.8\text{ kHz}$$

$$D = 1.5\text{kHz (60\% of peak deviation)}$$

6k60F2D

F2D represents a FM data transmission with the use of a modulating sub carrier

$$\begin{aligned} B_n &= 3.6 + 3 \times 1 \\ &= 6.6\text{ kHz} \end{aligned}$$

4. Fast Frequency Shift Keying (FFSK) 25kHz Bandwidth

Necessary bandwidth

Emission Designator

$$M = 1.8\text{ kHz}$$

$$D = 3\text{kHz (60\% of peak deviation)}$$

9k60F2D

F2D represents a FM data transmission with the use of a modulating sub carrier

$$\begin{aligned} B_n &= 3.6 + 6 \times 1 \\ &= 9.6\text{ kHz} \end{aligned}$$

TEST RESULTS

TRANSMITTER OUTPUT POWER (CONDUCTED)

SPECIFICATION: FCC 47 CFR 2.1046

GUIDE: TIA/EIA-603C 2.2.1

MEASUREMENT PROCEDURE:

1. Refer Annex A for Equipment set up.
2. The coaxial attenuator has an impedance of 50 Ohms.
3. The unmodulated output power was measured with an RF Power sensor connected to the modulation analyser.

MEASUREMENT RESULTS:

Manufacturer's Rated Output Power: Continuously Variable: 5 W to 50 W

50W 120V AC PA		
219.1 MHz	50 W nominal	5 W nominal
POWER (W)	51.6	5.1
Variation from Nominal (%)	+3.2	+2.0
Measurement Uncertainty (dB)	+/-0.6	

LIMIT CLAUSE: FCC 47 CFR 80.215

Manufacturer's Rated Output Power: Continuously Variable: 5 W to 50 W

50W 120V AC PA		
221.5 MHz	50 W nominal	5 W nominal
POWER (W)	51.8	5.2
Variation from Nominal (%)	+3.6	+4.0
Measurement Uncertainty (dB)	+/-0.6	

LIMIT CLAUSE: FCC 47 CFR 90.729

TELTEST Laboratories
Tait Electronics Limited
Report Number 2470

Manufacturer's Rated Output Power: Continuously Variable: 5 W to 50 W

50W 12V DC PA		
219.1 MHz	50 W nominal	5 W nominal
POWER (W)	48.3	4.9
Variation from Nominal (%)	-3.4	-2.0
Measurement Uncertainty (dB)	+/-0.6	

LIMIT CLAUSE: FCC 47 CFR 80.215

Manufacturer's Rated Output Power: Continuously Variable: 5 W to 50 W

50W 12V DC PA		
221.5 MHz	50 W nominal	5 W nominal
POWER (W)	48.8	4.9
Variation from Nominal (%)	-2.4	-2.0
Measurement Uncertainty (dB)	+/-0.6	

LIMIT CLAUSE: FCC 47 CFR 90.729

LIMIT CLAUSE: FCC 47 CFR 90.205 ®

Radio Type: Base Station Transceiver
Frequency Band: 193 MHz-225 MHz

The output power shall not exceed by more than 20%, the manufacturers rated output power for the particular transmitter.

TRANSMITTER AUDIO FREQUENCY RESPONSE - PRE-EMPHASIS

SPECIFICATION: FCC 47 CFR 2.1047 (a)

GUIDE: TIA/EIA-603C 2.2.6

MEASUREMENT PROCEDURE:

1. Refer Annex A for Equipment set up.
2. An audio input tone of 1000Hz was applied with the level set to obtain 20% of maximum deviation. This was used as the 0dB reference point.
3. The AF was varied while the audio level was held constant.
4. The response in dB relative to 1000Hz was measured.

MEASUREMENT RESULTS:

See the plots on the following pages for 12.5 kHz & 25 kHz channel spacings.

219.1 MHz 12.5 kHz Channel Spacing 50W AC

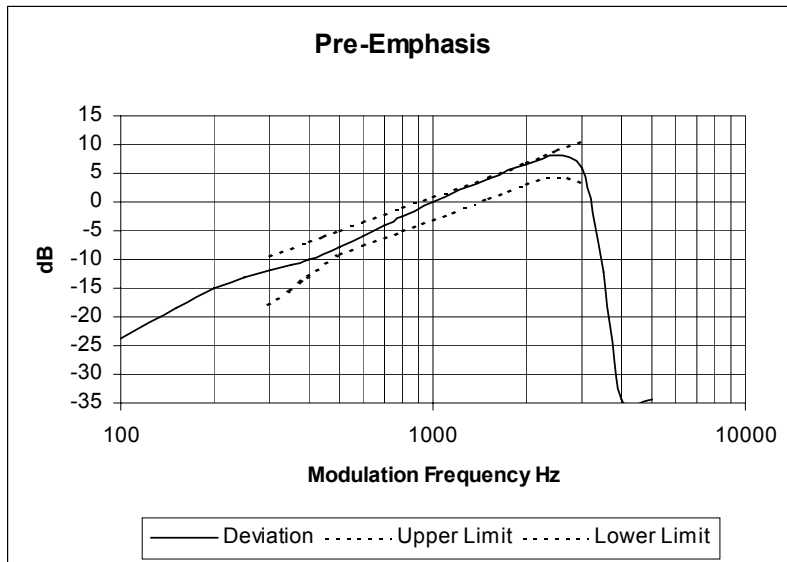

219.1 MHz 25.0 kHz Channel Spacing 50W AC

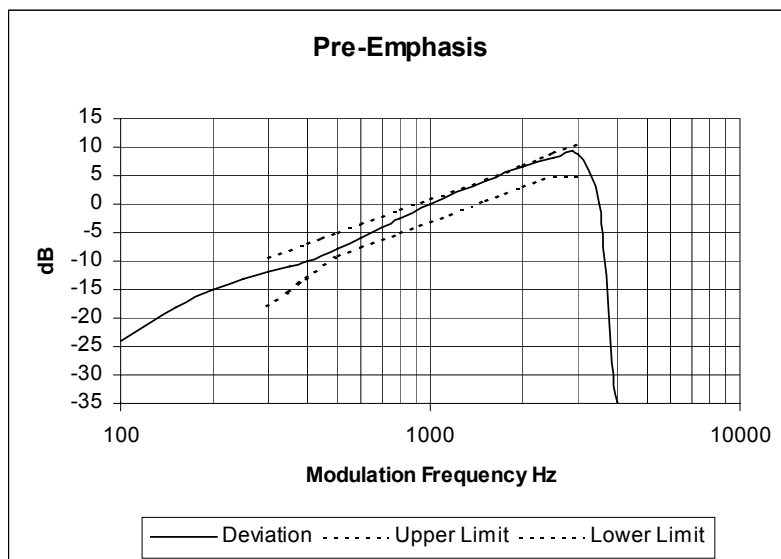

LIMIT CLAUSE: TIA/EIA-603C 3.2.6

TELTEST Laboratories
Tait Electronics Limited
Report Number 2470

221.5 MHz

12.5 kHz Channel Spacing

50W AC

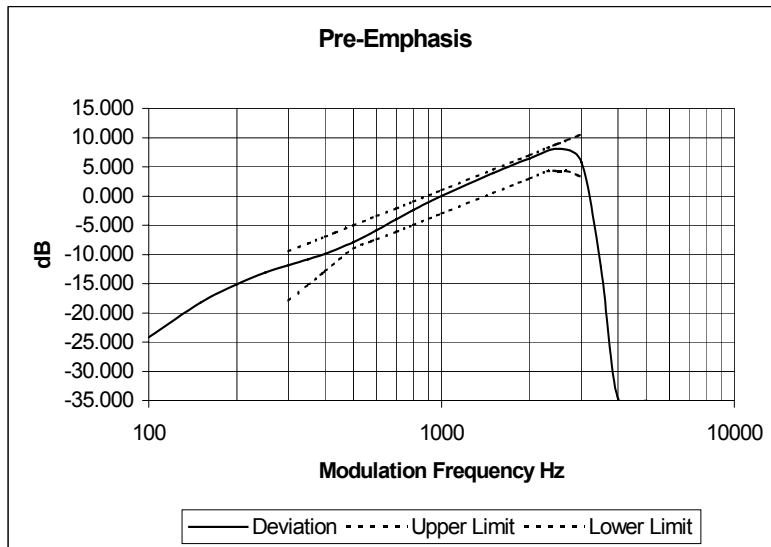

LIMIT CLAUSE:

TIA/EIA-603C 3.2.6

TRANSMITTER MODULATION LIMITING

SPECIFICATION: FCC 47 CFR 2.1047 (b)

MEASUREMENT PROCEDURE:

1. Refer Annex A for Equipment set up.
2. The modulation response was measured at three audio frequencies while varying the input level.
3. Measurements were made for both Positive and Negative Deviation.

MEASUREMENT RESULTS:

See the plots on the following pages for 12.5 kHz & 25 kHz channel spacings.

LIMIT CLAUSE: TIA/EIA-603C 1.3.4.4

Tx FREQUENCY: 219.1 MHz (12.5 kHz) 50W 120VAC PA

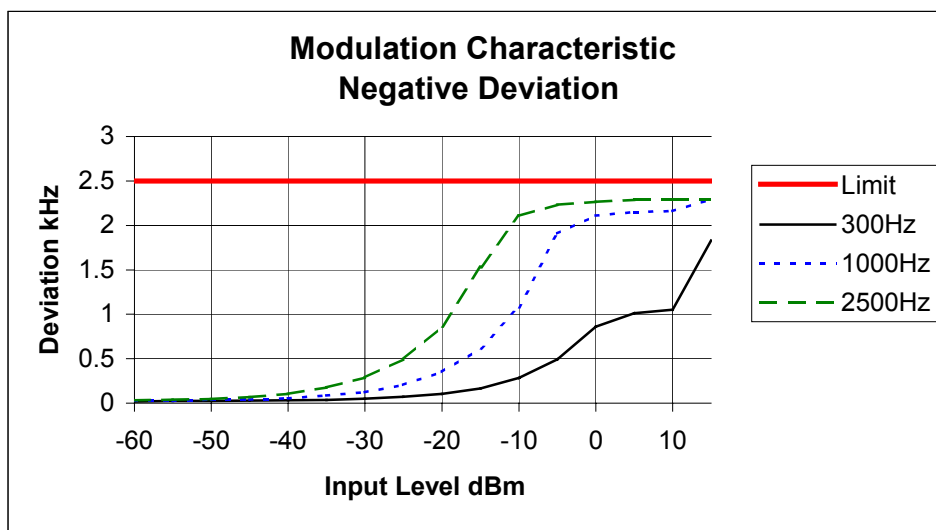
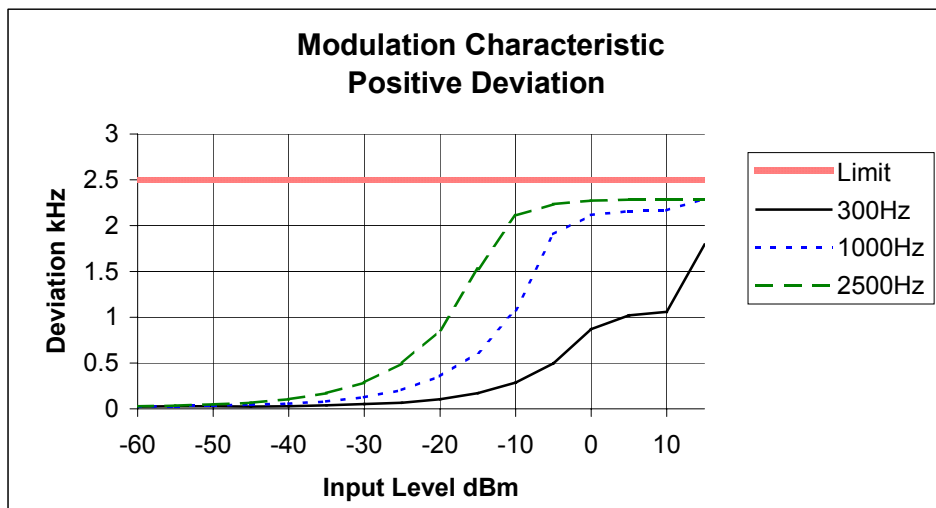

TRANSMITTER MODULATION LIMITING

SPECIFICATION: FCC CFR 2.1047 (b)

Tx FREQUENCY: 219.1 MHz (25.0 kHz) 50W 120VAC PA

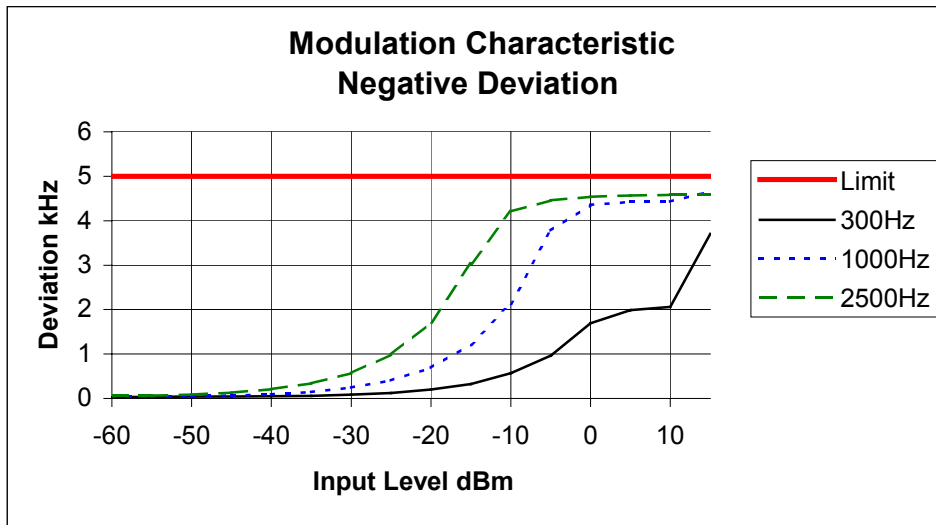
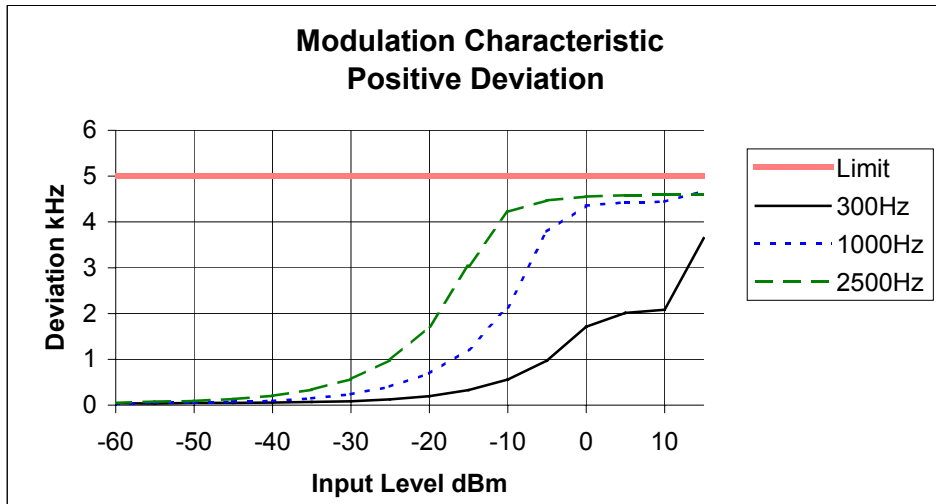

TRANSMITTER MODULATION LIMITING

SPECIFICATION: FCC CFR 2.1047 (b)

Tx FREQUENCY: 221.5 MHz (12.5 kHz) 50W 120VAC PA

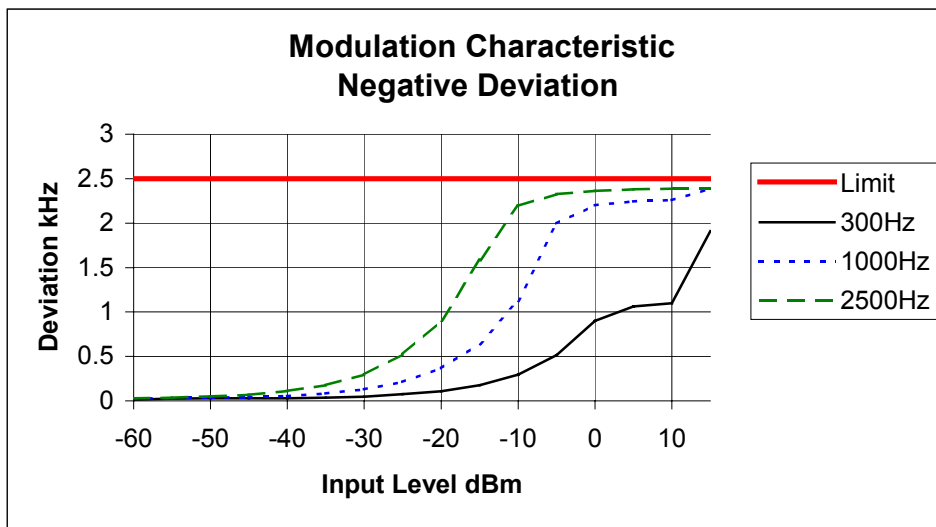
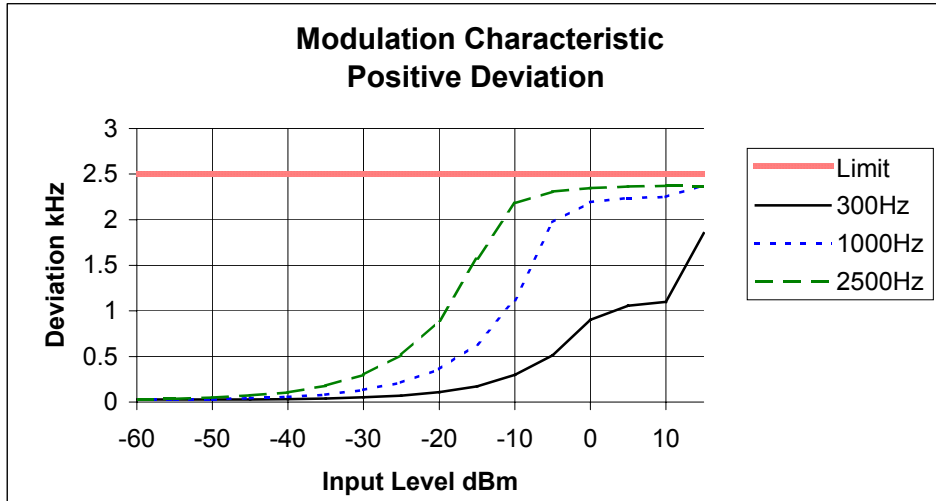

TRANSMITTER MODULATION LIMITING

SPECIFICATION: FCC 47 CFR 2.1047 (b)

MEASUREMENT PROCEDURE:

4. Refer Annex A for Equipment set up.
5. The modulation response was measured at three audio frequencies while varying the input level.
6. Measurements were made for both Positive and Negative Deviation.

MEASUREMENT RESULTS:

See the plots on the following pages for 12.5 kHz & 25 kHz channel spacings.

LIMIT CLAUSE: TIA/EIA-603C 1.3.4.4

Tx FREQUENCY: 219.1 MHz (12.5 kHz) 50W 12VDC PA

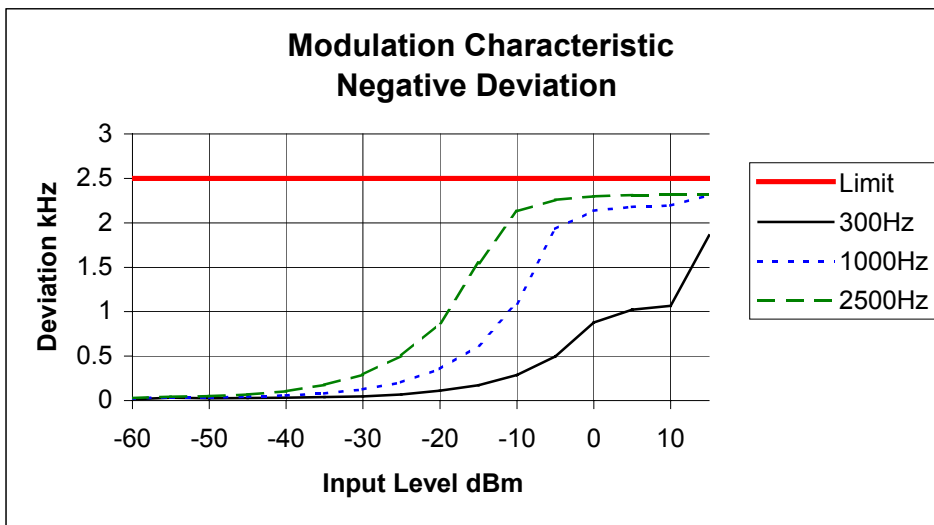
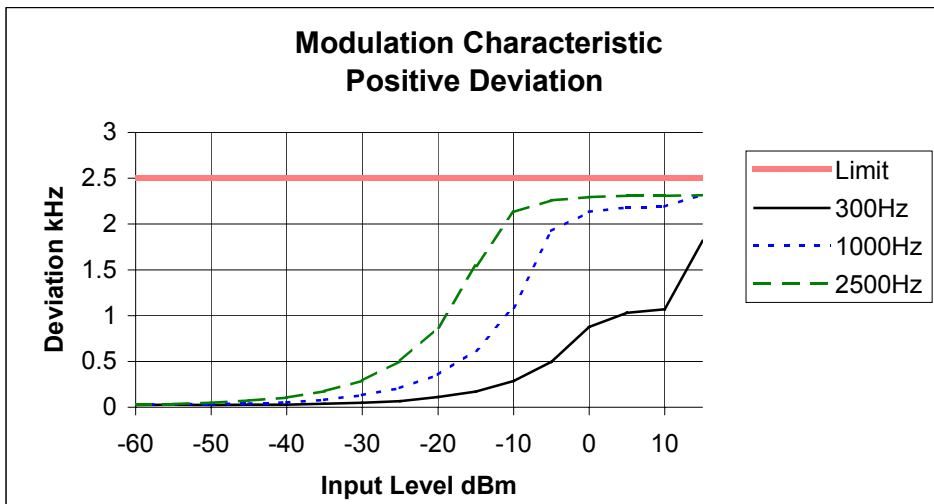

TRANSMITTER MODULATION LIMITING

SPECIFICATION: FCC CFR 2.1047 (b)

Tx FREQUENCY: 219.1 MHz (25.0 kHz) 50W 12VDC PA

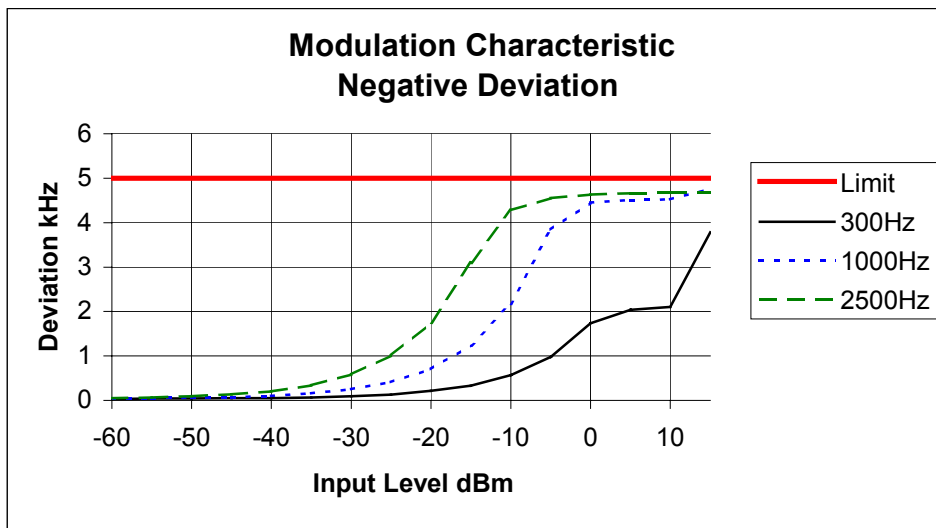
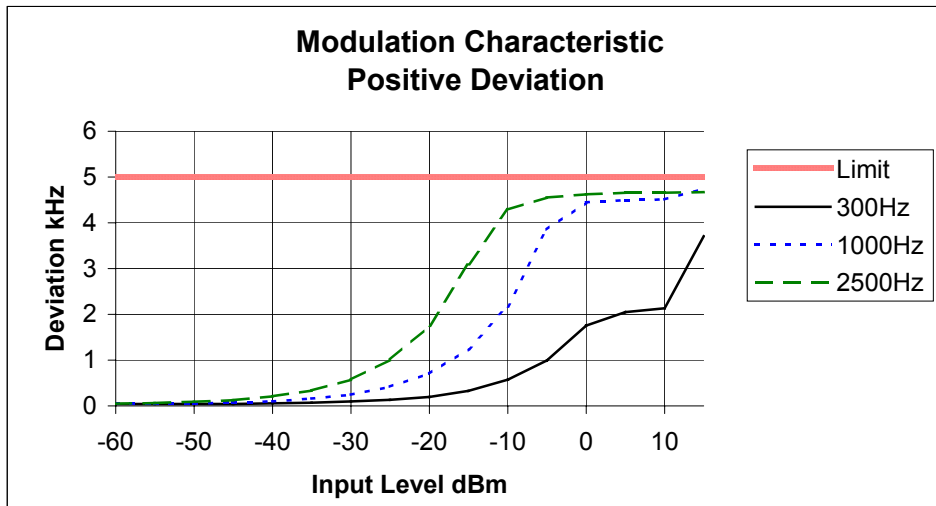

TRANSMITTER MODULATION LIMITING

SPECIFICATION: FCC CFR 2.1047 (b)

Tx FREQUENCY: 221.5 MHz (12.5 kHz) 50W 12VDC PA

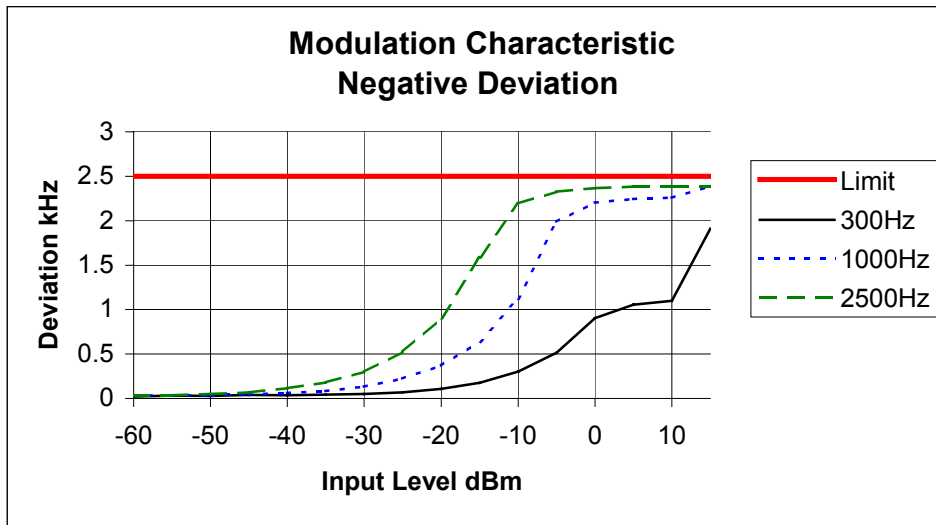
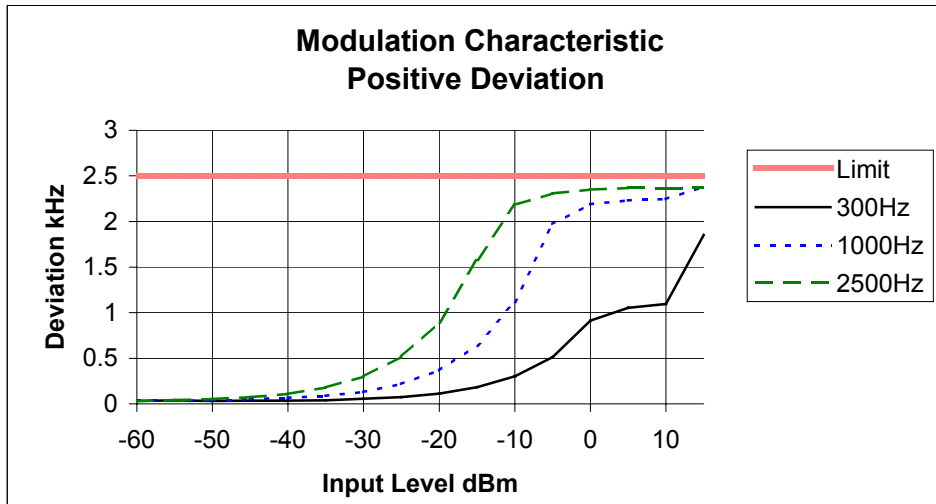

SIDEBAND SPECTRUM

SPECIFICATION: FCC 47 CFR 2.1049 (c)

GUIDE: TIA/EIA-603C 2.2.11
TIA -102.CAAA - A

MEASUREMENT PROCEDURE:

1. Refer Annex A for Equipment Set up.
2. **For analogue measurements:** The EUT was modulated by a 2500Hz tone at an input level 16dB above a level that produced 50% deviation. The input level was established at the frequency of maximum response of the audio modulating circuit.

For FFSK data measurements: The EUT was modulated with an externally generated pseudo random bit sequence at the appropriate Baud rate of 1200 bps producing 60% FM deviation.

3. The Sideband Spectrum was measured on the Spectrum Analyser, with bandwidth settings as follows.

Emission Mask B,C and F – Resolution bandwidth = 300Hz, Video Bandwidth = 3 kHz
Emission Mask D – Resolution bandwidth = 100Hz, Video Bandwidth = 1 kHz

MEASUREMENT RESULTS:

See the plots on the following pages tested at 219.1 MHz and 221.5 MHz, 50 and 5 Watts, 12.5 kHz & 25 kHz channel spacings respectively.

LIMIT CLAUSE: FCC 47 CFR 90.210

EMISSION MASKS:

Emission Mask D	12.5 kHz Channel Spacing	Analogue and FFSK
Emission Mask B	25.0 kHz Channel Spacing	Analogue
Emission Mask C	25.0 kHz Channel Spacing	FFSK
Emission Mask Fx5	12.5 kHz Channel Spacing	Analogue and FFSK

DATA SPEED:

FFSK	1200 bps	12.5 kHz Channel Spacing
FFSK	1200 bps	25 kHz Channel Spacing

Occupied Bandwidth

SPECIFICATION: FCC CFR 2.1049 (c)

Analogue Voice : 120V AC PA

219.1 MHz Tx Power: 50 W Channel Spacing: 12.5 kHz Mask: D

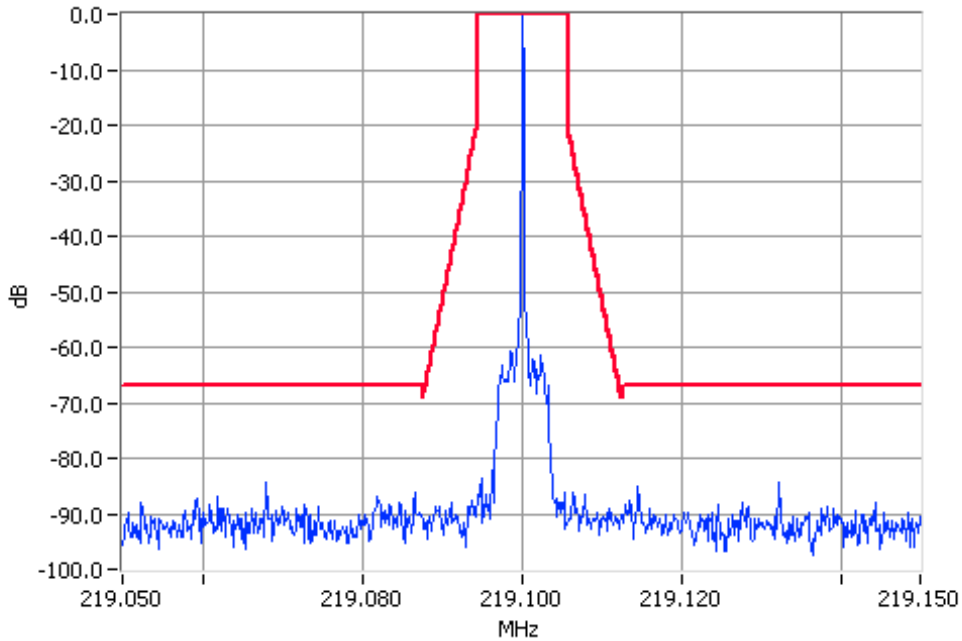

Unmodulated 219.1000MHz Mask D 50W Pass
RBW=100Hz VBW=1000Hz

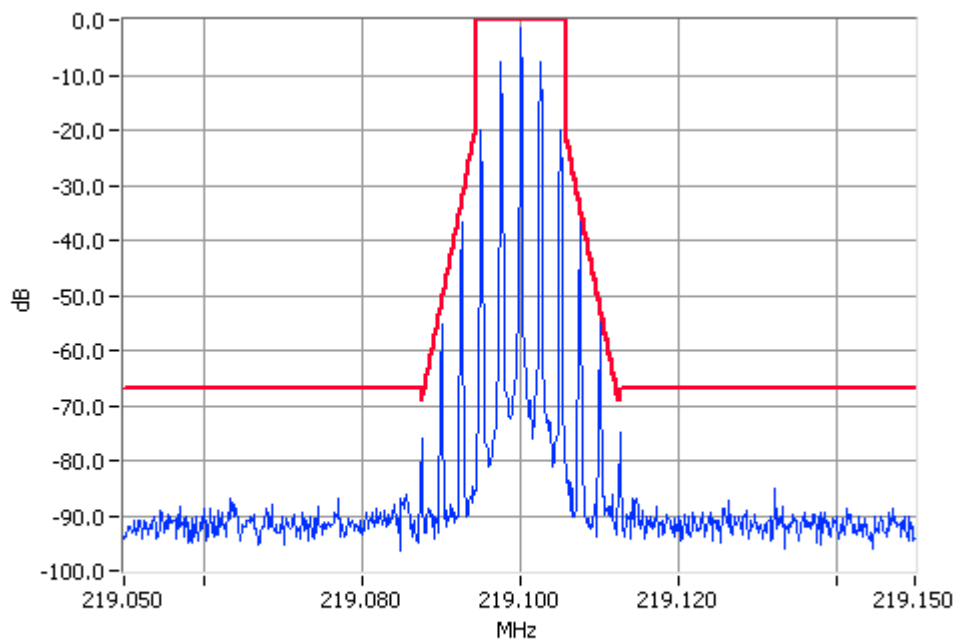

Analogue Modulation 219.1000MHz Mask D 50W Pass
RBW=100Hz VBW=1000Hz

Analogue Voice : 120V AC PA

219.1 MHz Tx Power: 5 W Channel Spacing: 12.5 kHz Mask: D

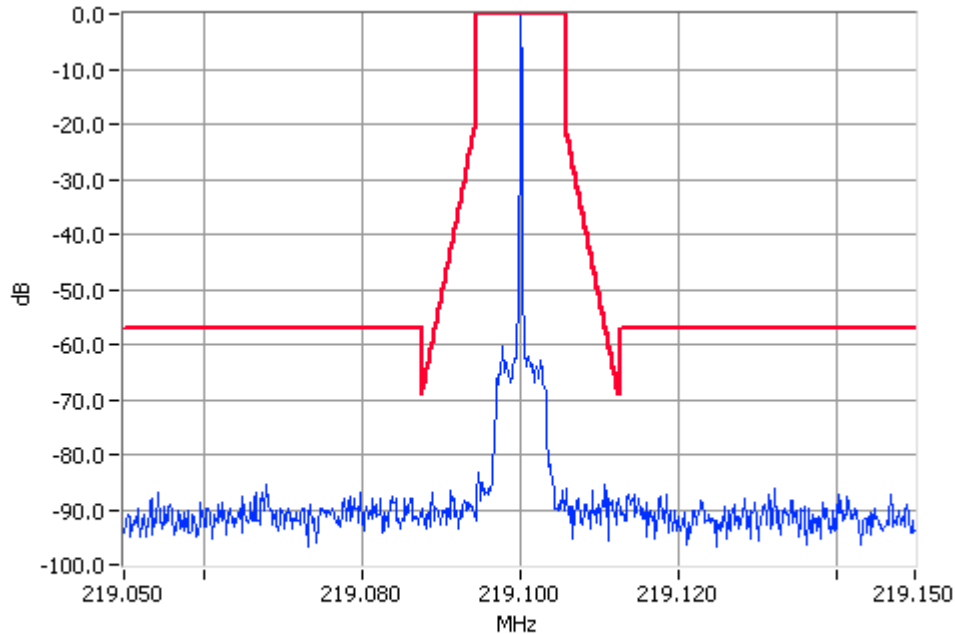

Unmodulated 219.1000MHz Mask D 5W Pass
RBW=100Hz VBW=1000Hz

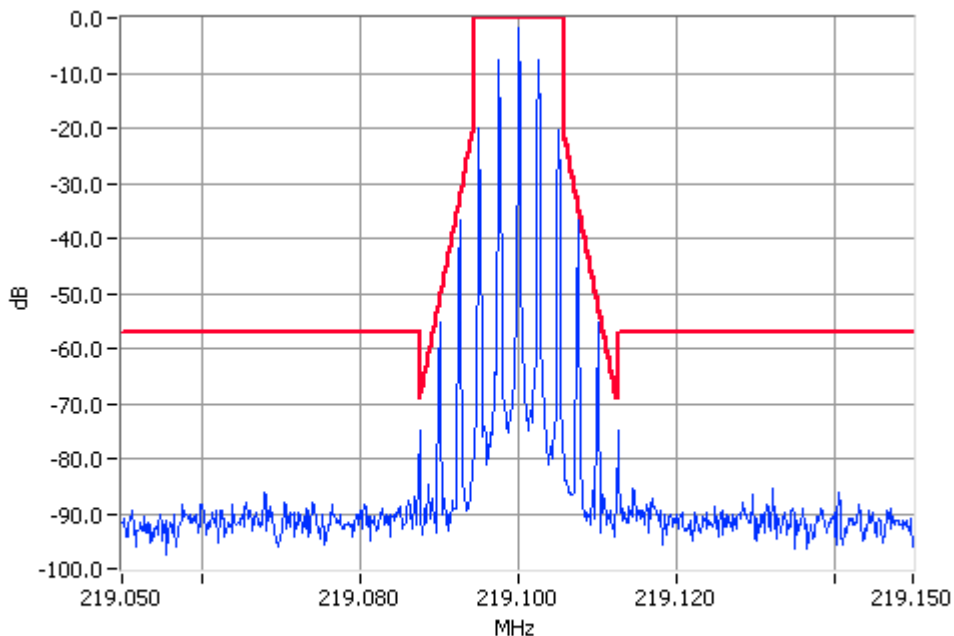

Analogue Modulation 219.1000MHz Mask D 5W Pass
RBW=100Hz VBW=1000Hz

Analogue Voice : 120V AC PA

221.5 MHz Tx Power: 50 W Channel Spacing: 12.5 kHz Mask: Fx5

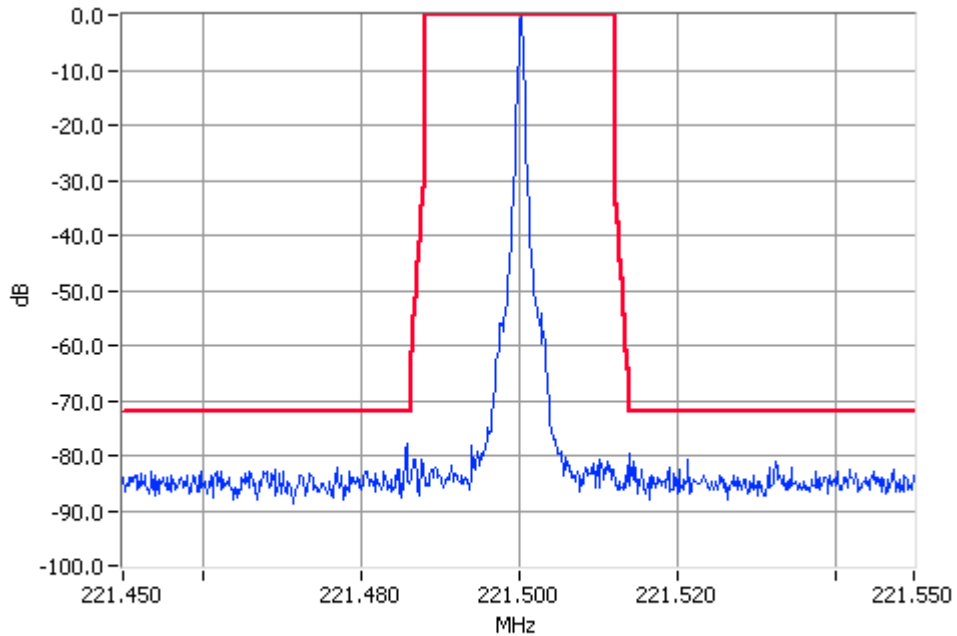

Unmodulated 221.5000MHz Mask Fx5 50W Pass
RBW=300Hz VBW=3000Hz

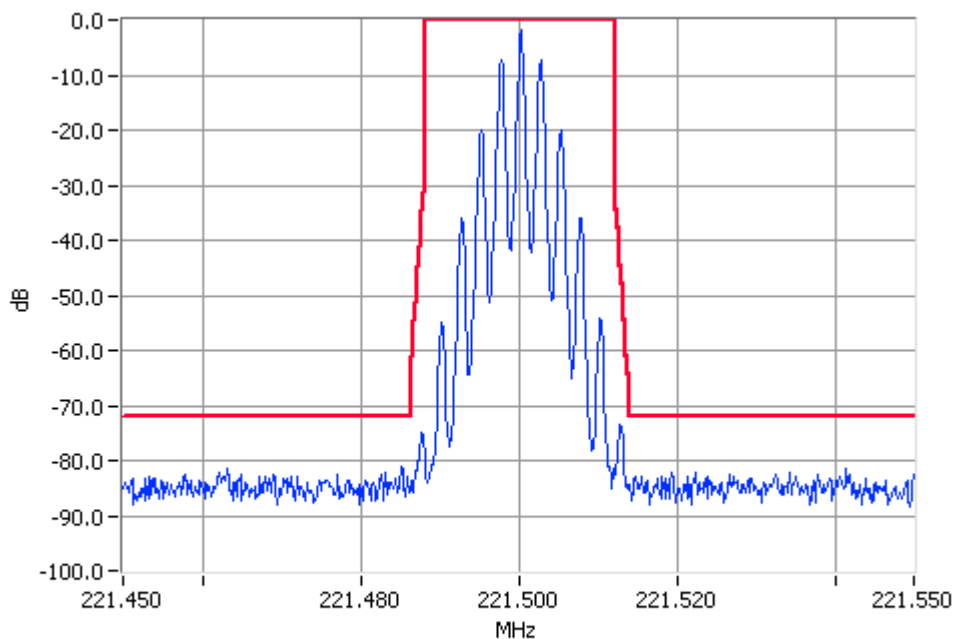

Analogue Modulation 221.5000MHz Mask Fx5 50W Pass
RBW=300Hz VBW=3000Hz

Analogue Voice : 120V AC PA

221.5 MHz Tx Power: 5 W Channel Spacing: 12.5 kHz Mask: Fx5

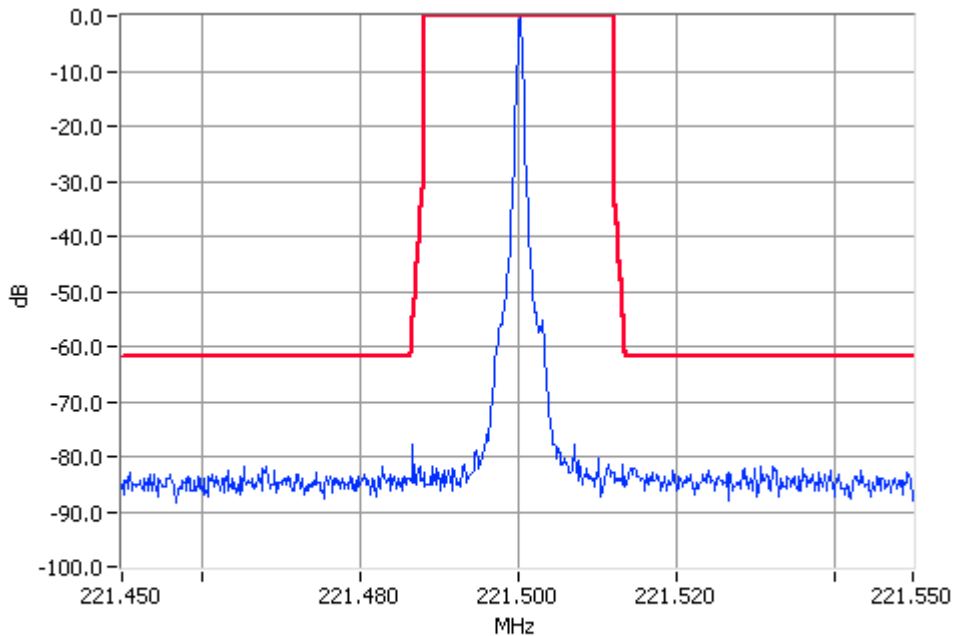

Unmodulated 221.5000MHz Mask Fx5 5W Pass
RBW=300Hz VBW=3000Hz

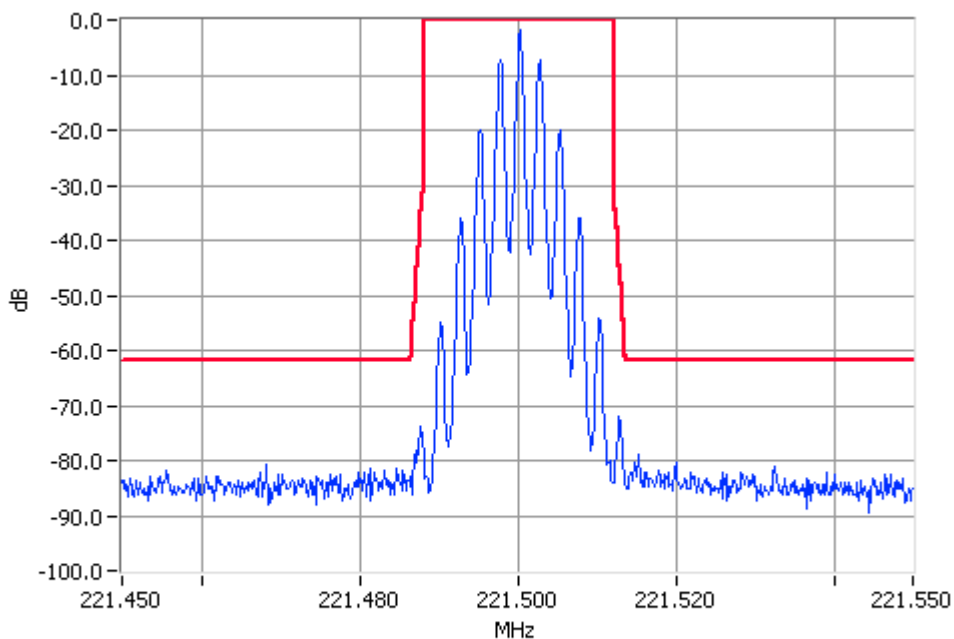

Analogue Modulation 221.5000MHz Mask Fx5 5W Pass
RBW=300Hz VBW=3000Hz

FFSK : 120V AC PA

219.1 MHz Tx Power: 50 W Channel Spacing: 12.5 kHz Mask: D

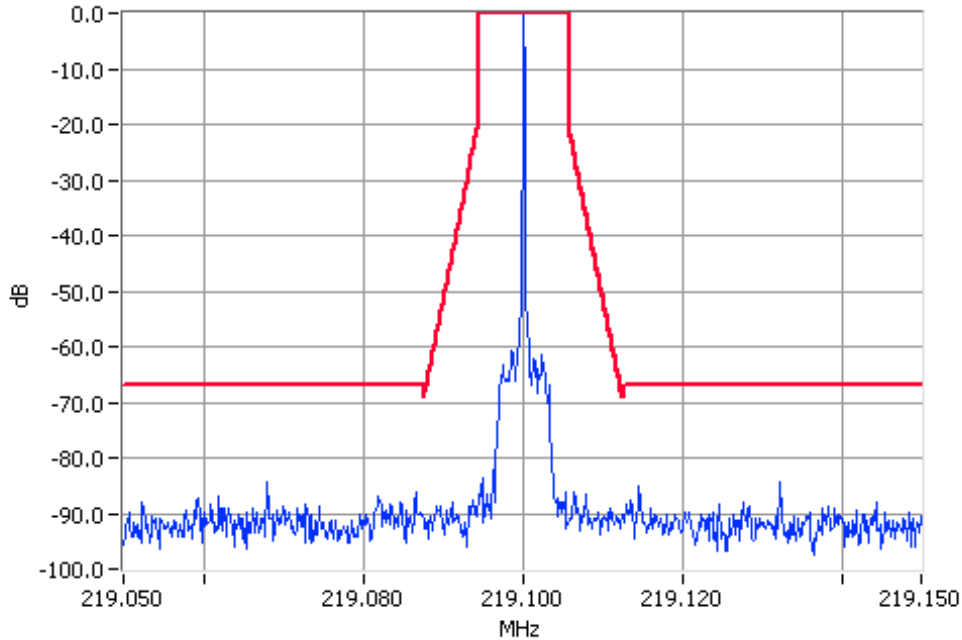

**Unmodulated 219.1000MHz Mask D 50W Pass
RBW=100Hz VBW=1000Hz**

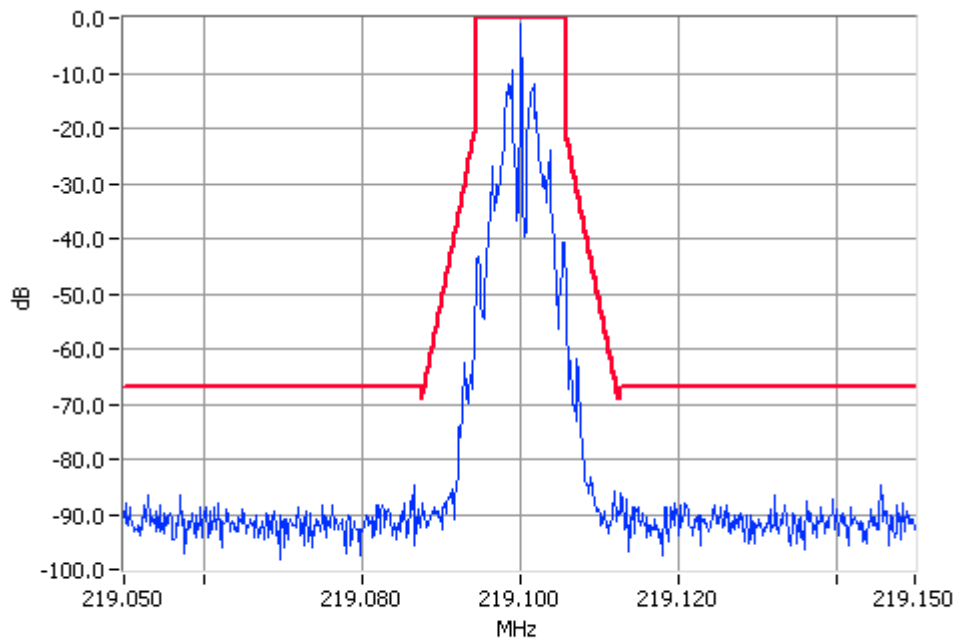

**Digital Modulation 219.1000MHz Mask D 50W Pass
RBW=100Hz VBW=1000Hz**

FFSK : 120V AC PA

219.1 MHz Tx Power: 5 W Channel Spacing: 12.5 kHz Mask: D

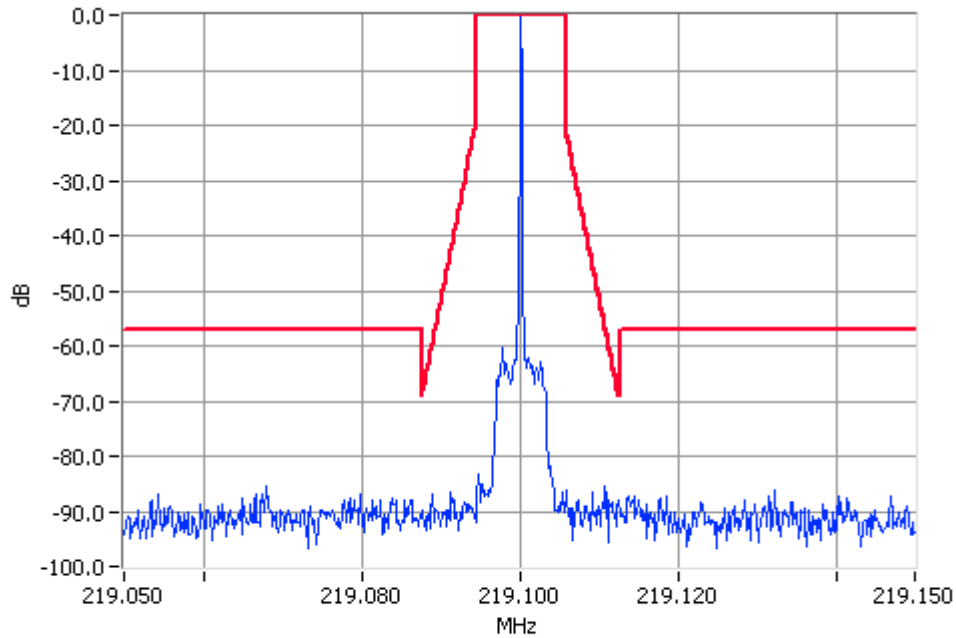

Unmodulated 219.1000MHz Mask D 5W Pass
RBW=100Hz VBW=1000Hz

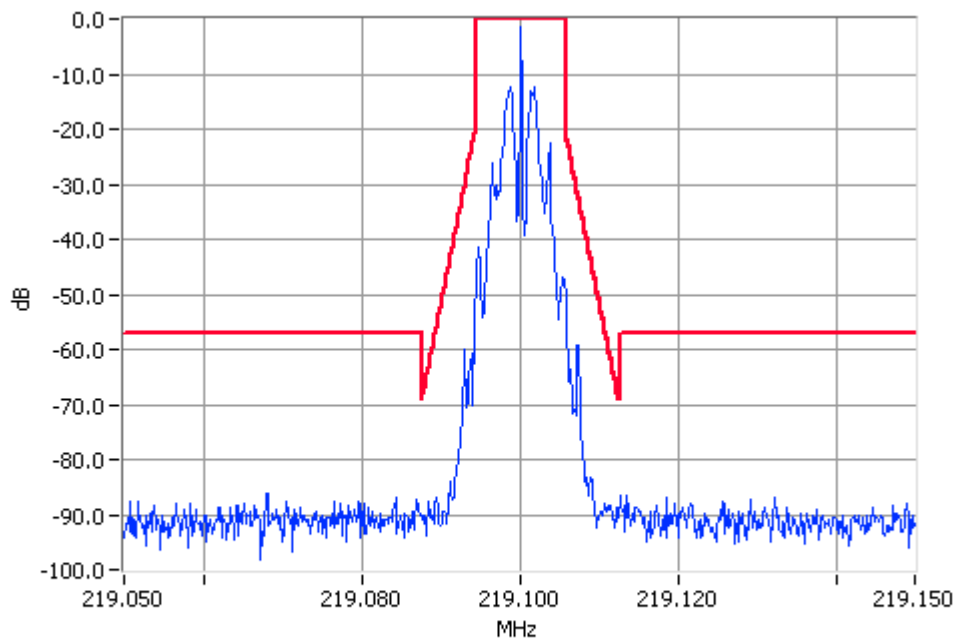

Digital Modulation 219.1000MHz Mask D 5W Pass
RBW=100Hz VBW=1000Hz

FFSK : 120V AC PA

221.5 MHz Tx Power: 50 W Channel Spacing: 12.5 kHz Mask: Fx5

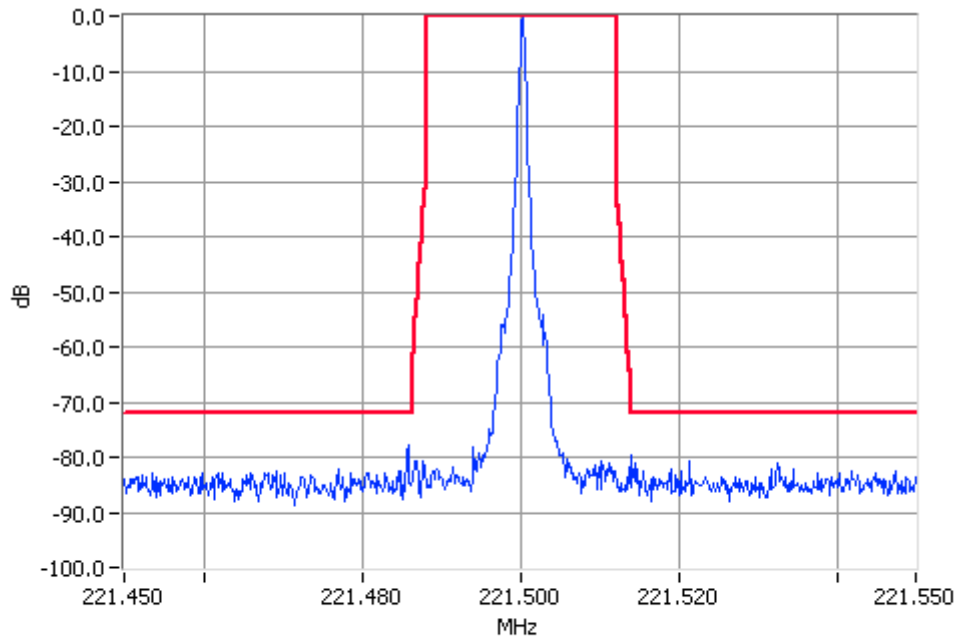

**Unmodulated 221.500MHz Mask Fx5 50W Pass
RBW=300Hz VBW=3000Hz**

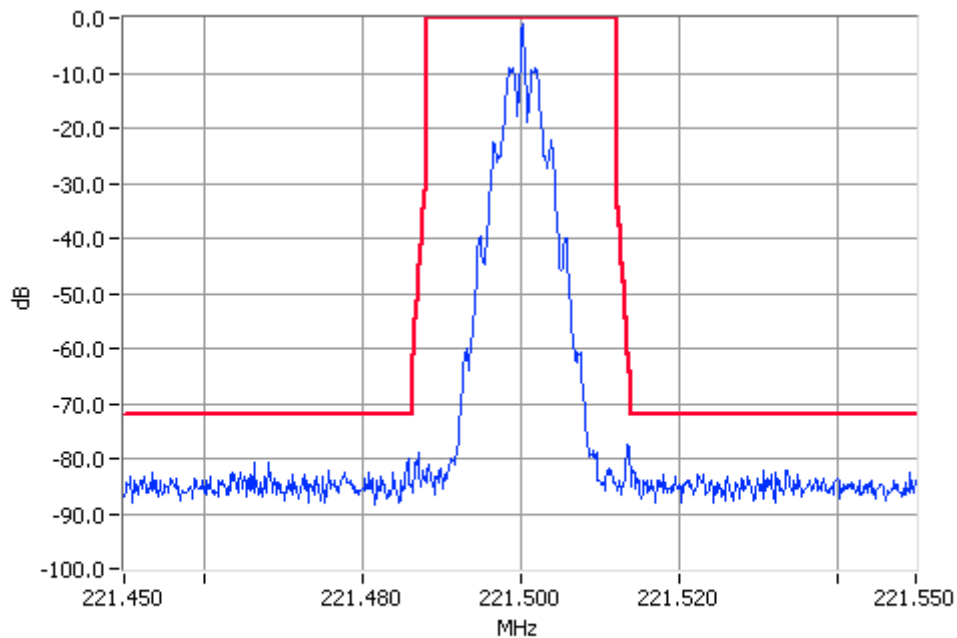

**Digital Modulation 221.500MHz Mask Fx5 50W Pass
RBW=300Hz VBW=3000Hz**

FFSK : 120V AC PA

221.5 MHz Tx Power: 5 W Channel Spacing: 12.5 kHz Mask: Fx5

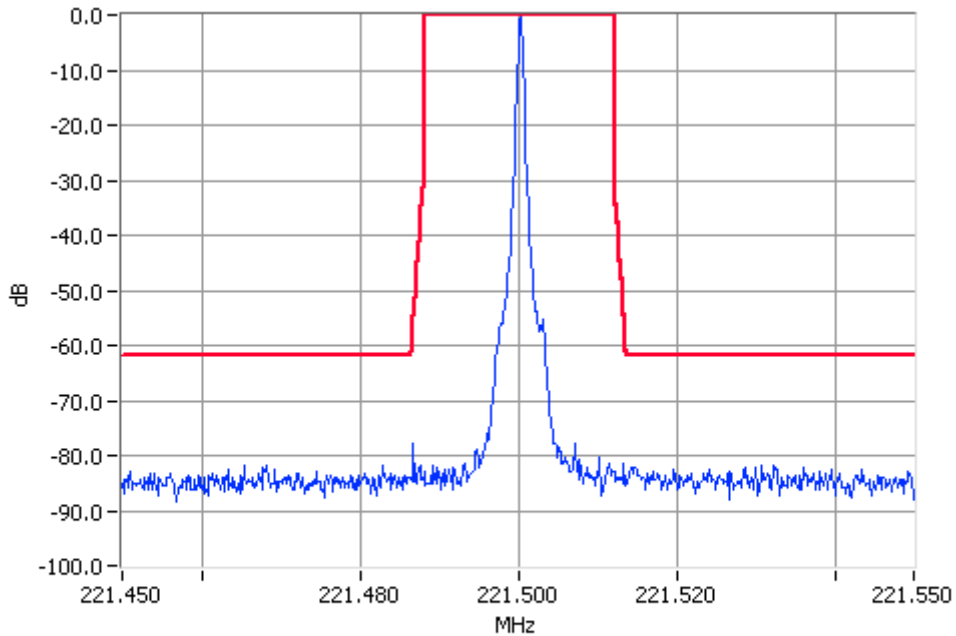

Unmodulated 221.5000MHz Mask Fx5 5W Pass
RBW=300Hz VBW=3000Hz

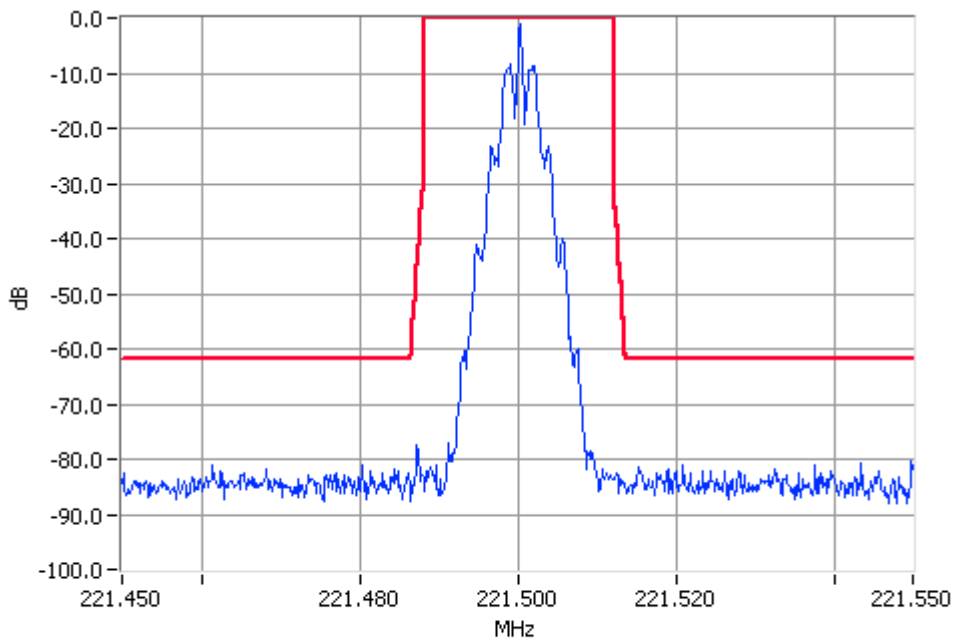

Digital Modulation 221.5000MHz Mask Fx5 5W Pass
RBW=300Hz VBW=3000Hz

Analogue Voice : 120V AC PA

219.1 MHz Tx Power: 50 W Channel Spacing: 25.0 kHz Mask: B

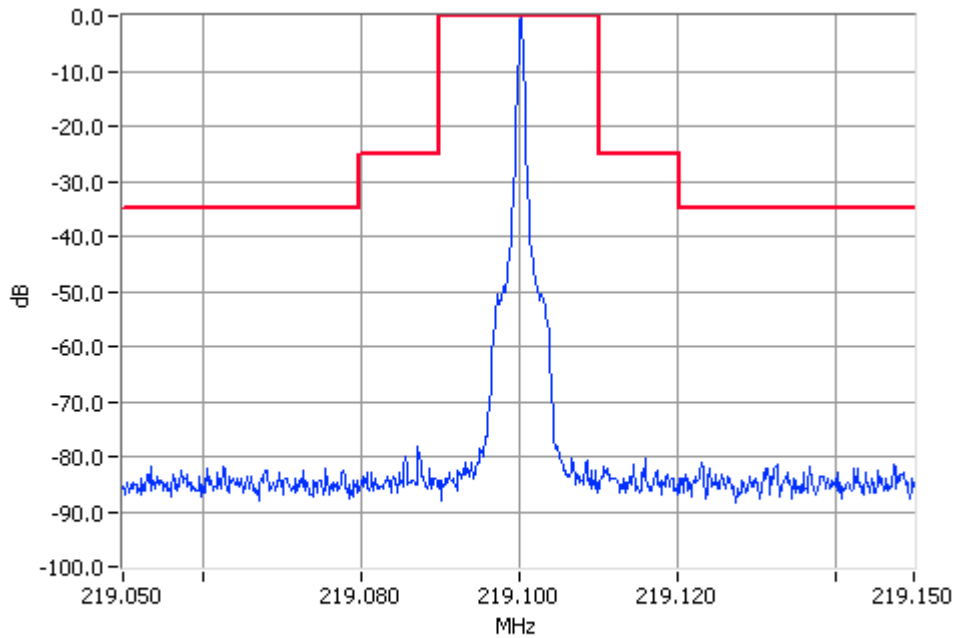

**Unmodulated 219.1000MHz Mask B 50W Pass
RBW=300Hz VBW=3000Hz**

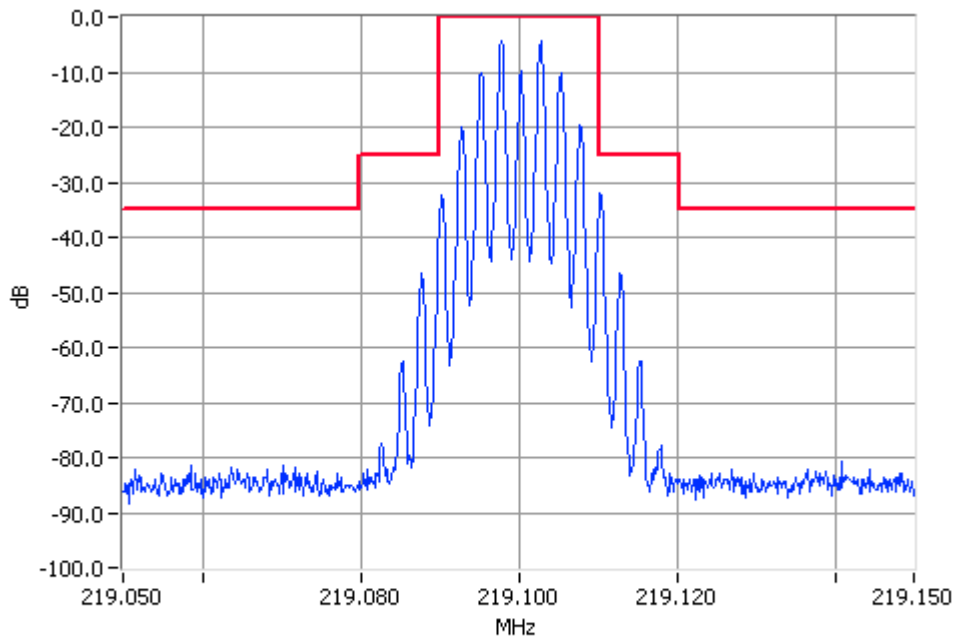

**Analogue Modulation 219.1000MHz Mask B 50W Pass
RBW=300Hz VBW=3000Hz**

Analogue Voice : 120V AC PA

219.1 MHz Tx Power: 5 W Channel Spacing: 25.0 kHz Mask: B

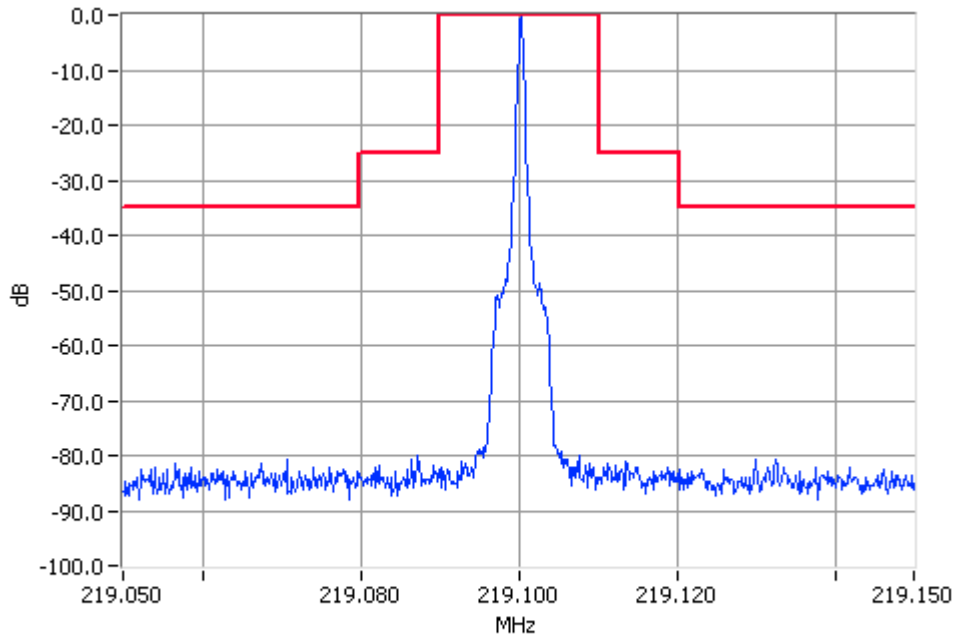

**Unmodulated 219.1000MHz Mask B 5W Pass
RBW=300Hz VBW=3000Hz**

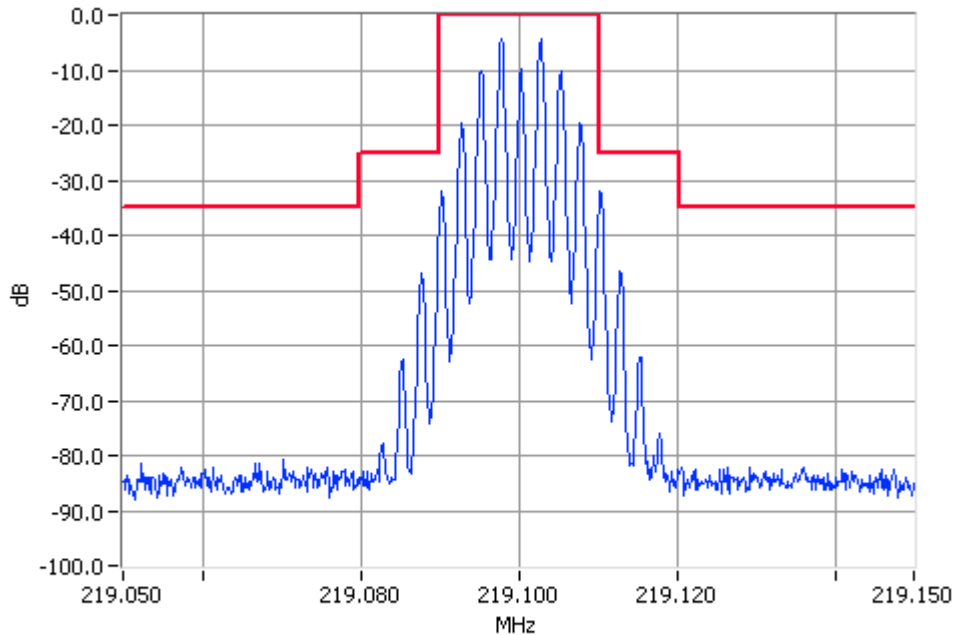

**Analogue Modulation 219.1000MHz Mask B 5W Pass
RBW=300Hz VBW=3000Hz**

FFSK : 120V AC PA

219.1 MHz Tx Power: 50 W Channel Spacing: 25.0 kHz Mask: C

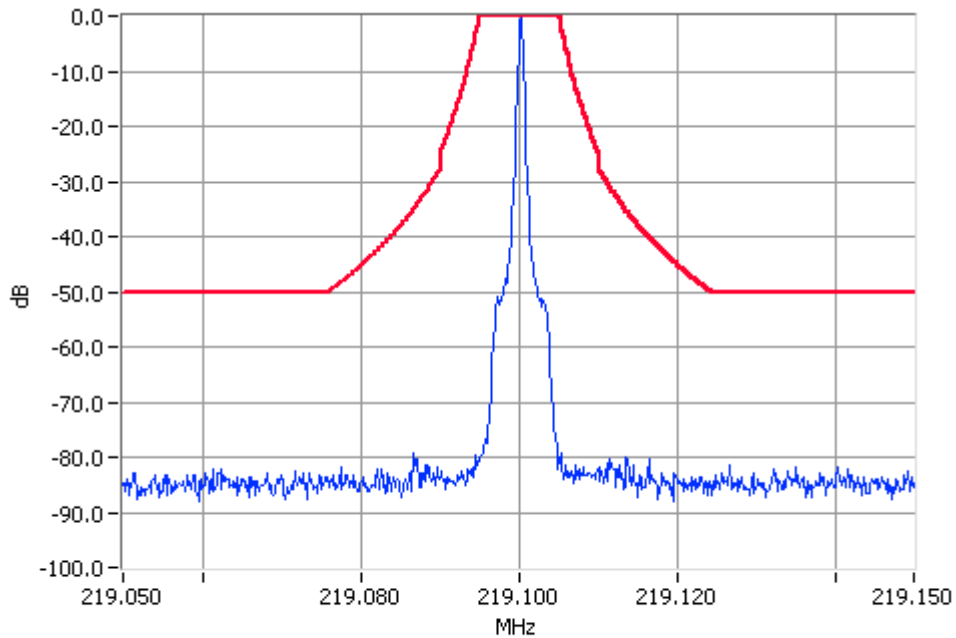

Unmodulated 219.1000MHz Mask C 50W Pass
RBW=300Hz VBW=3000Hz

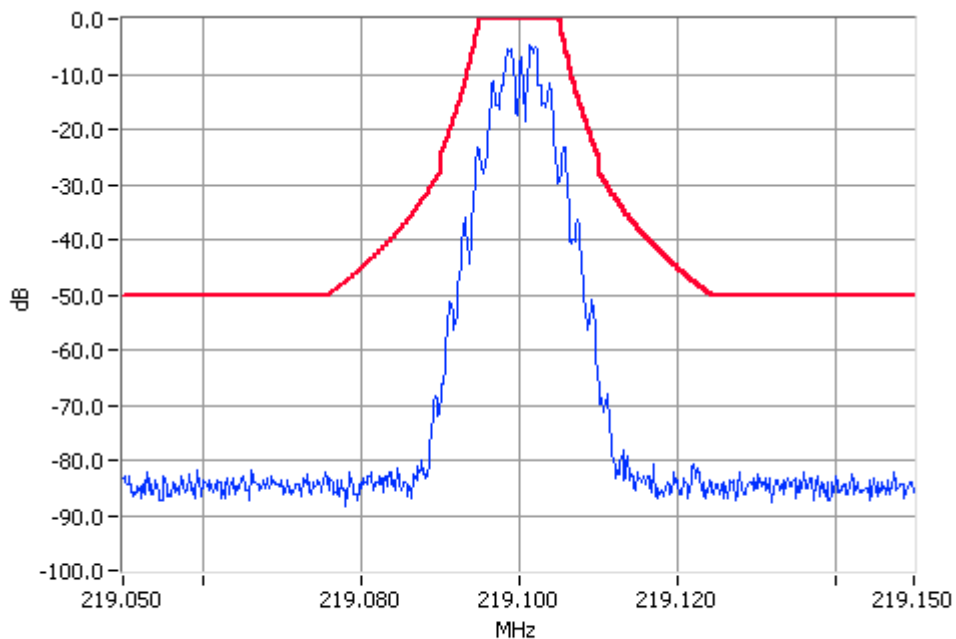

Digital Modulation 219.1000MHz Mask C 50W Pass
RBW=300Hz VBW=3000Hz

FFSK : 120V AC PA

219.1 MHz Tx Power: 5 W Channel Spacing: 25.0 kHz Mask: C

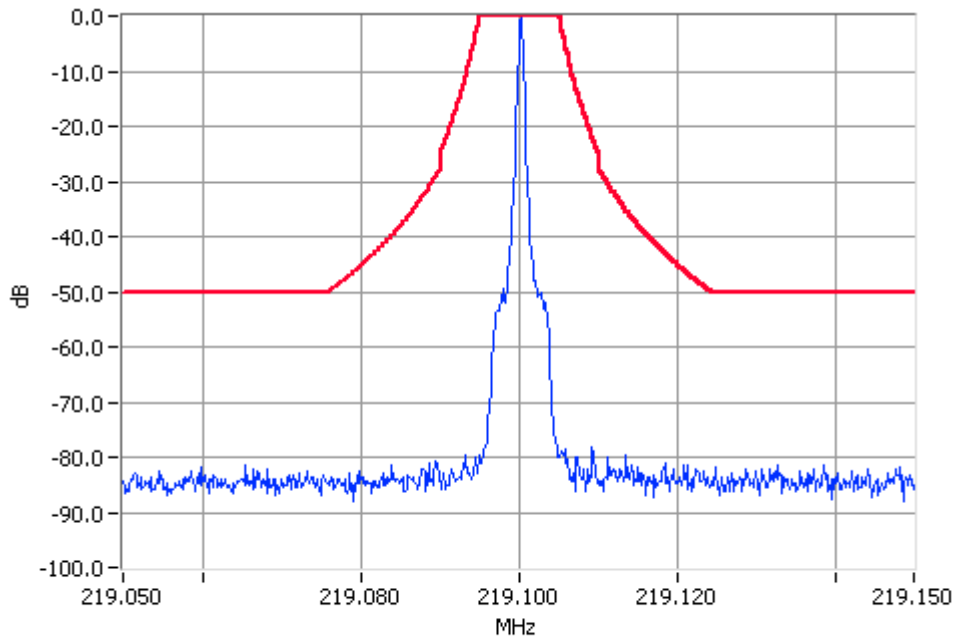

**Unmodulated 219.1000MHz Mask C 5W Pass
RBW=300Hz VBW=3000Hz**

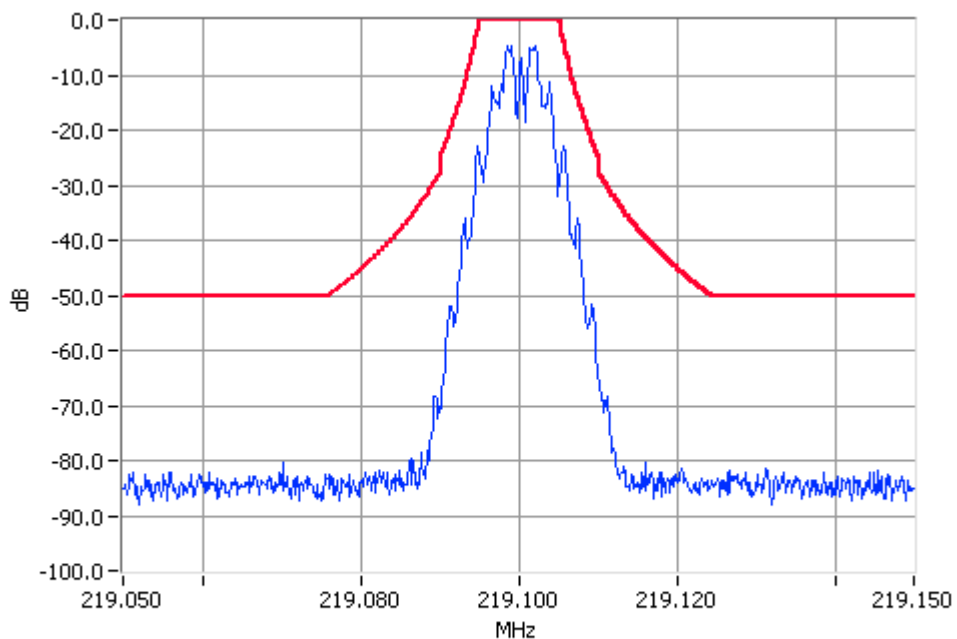

**Digital Modulation 219.1000MHz Mask C 5W Pass
RBW=300Hz VBW=3000Hz**

Analogue Voice : 12V DC PA

219.1 MHz Tx Power: 50 W Channel Spacing: 12.5 kHz Mask: D

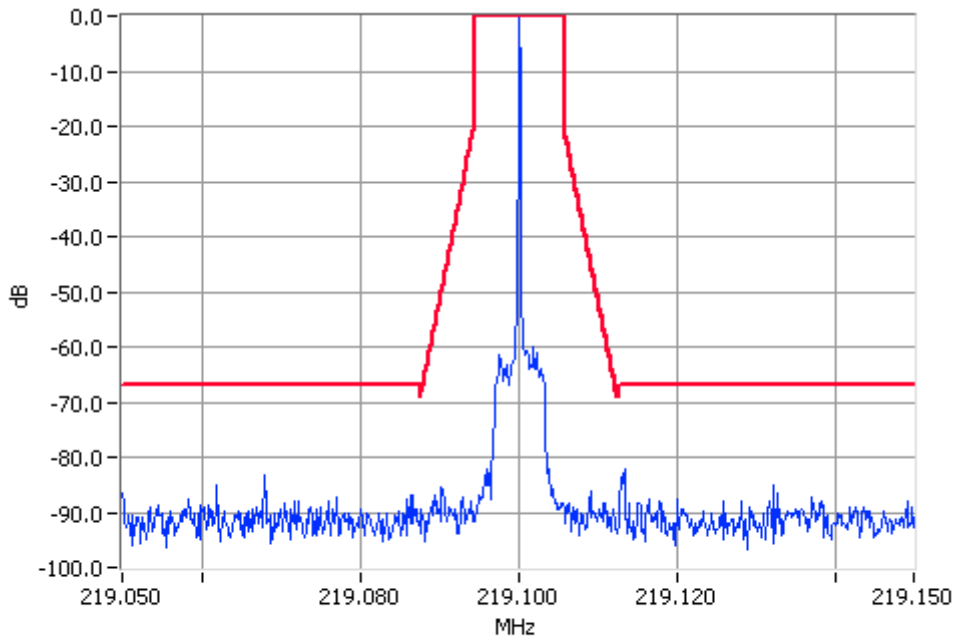

**Unmodulated 219.1000MHz Mask D 50W Pass
RBW=100Hz VBW=1000Hz**

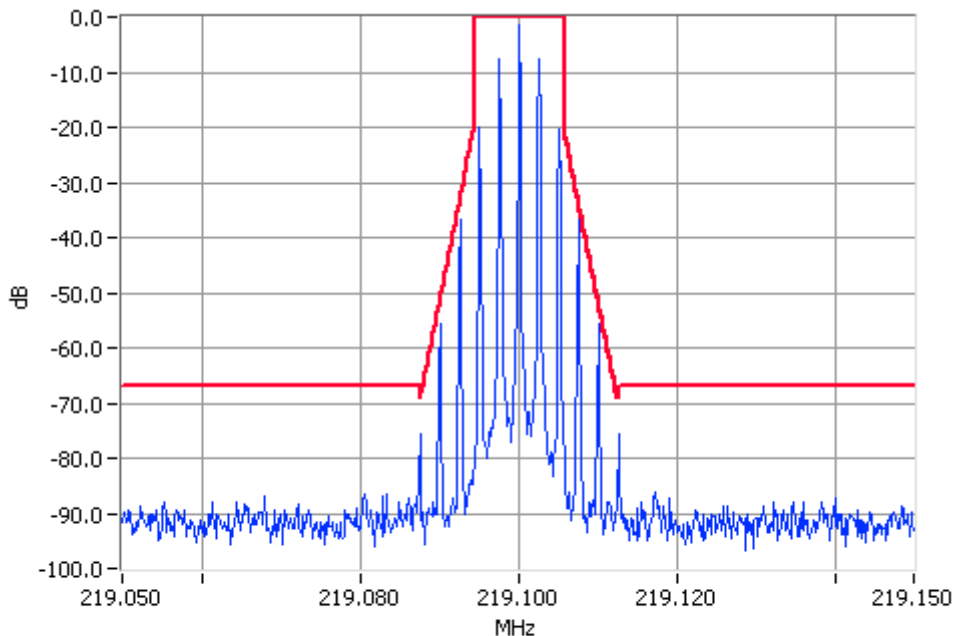

**Analogue Modulation 219.1000MHz Mask D 50W Pass
RBW=100Hz VBW=1000Hz**

Analogue Voice : 12V DC PA

219.1 MHz Tx Power: 5W Channel Spacing: 12.5 kHz Mask: D

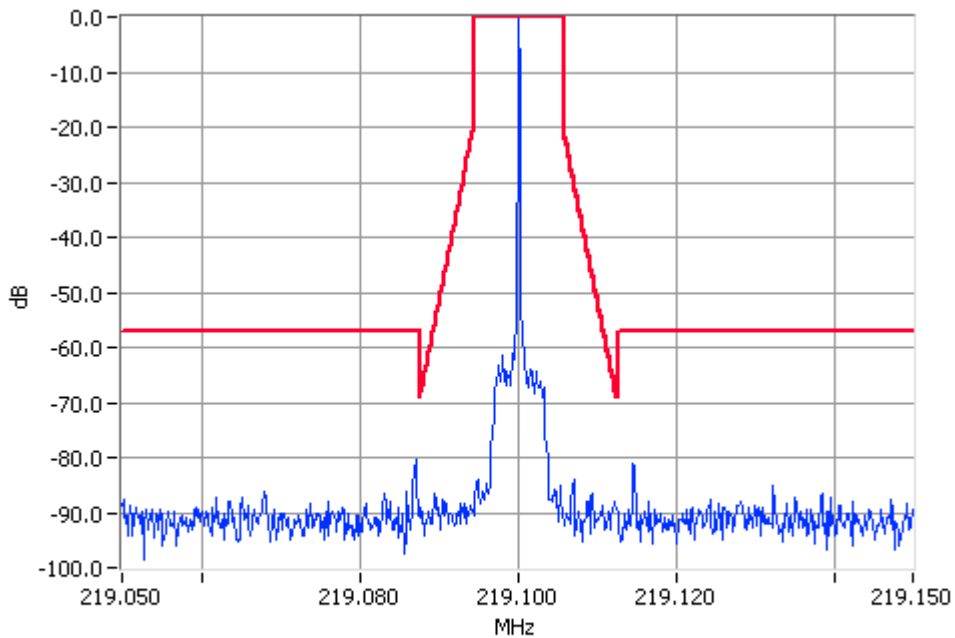

Unmodulated 219.1000MHz Mask D 5W Pass
RBW=100Hz VBW=1000Hz

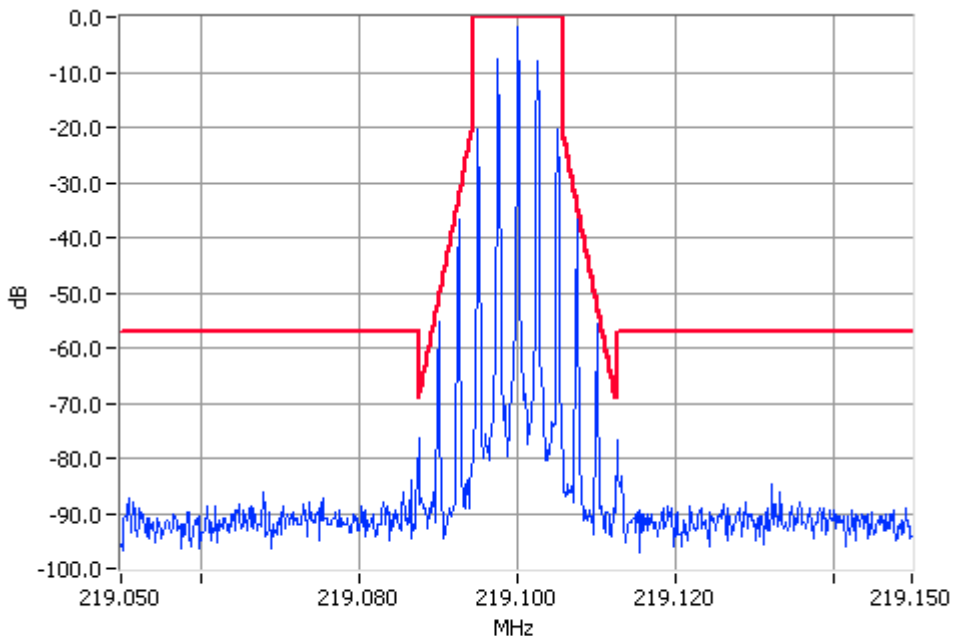

Analogue Modulation 219.1000MHz Mask D 5W Pass
RBW=100Hz VBW=1000Hz

Analogue Voice : 12V DC PA

219.1 MHz Tx Power: 50 W Channel Spacing: 12.5 kHz Mask: Fx5

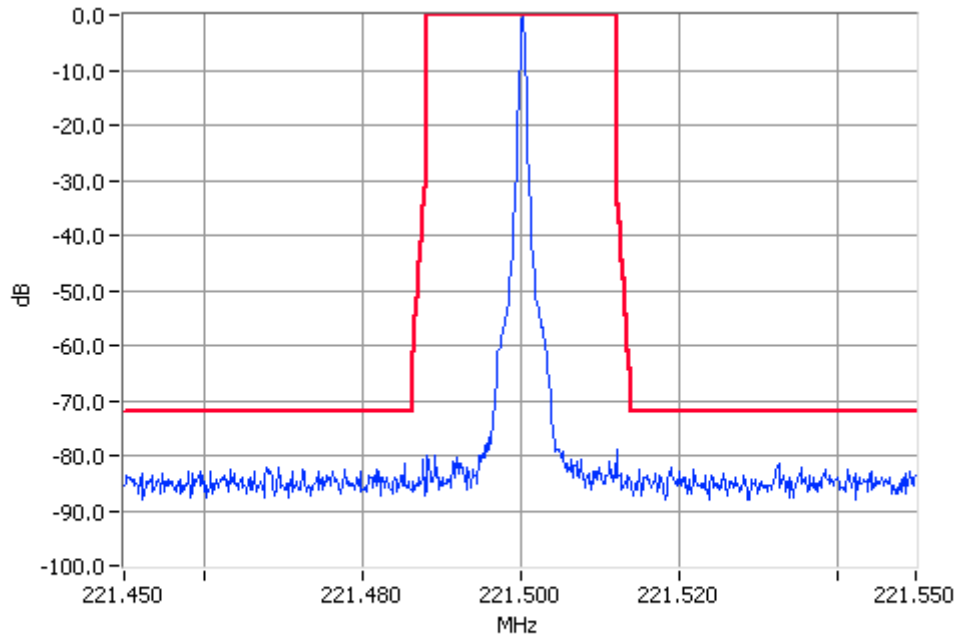

Unmodulated 221.5000MHz Mask Fx5 50W Pass
RBW=300Hz VBW=3000Hz

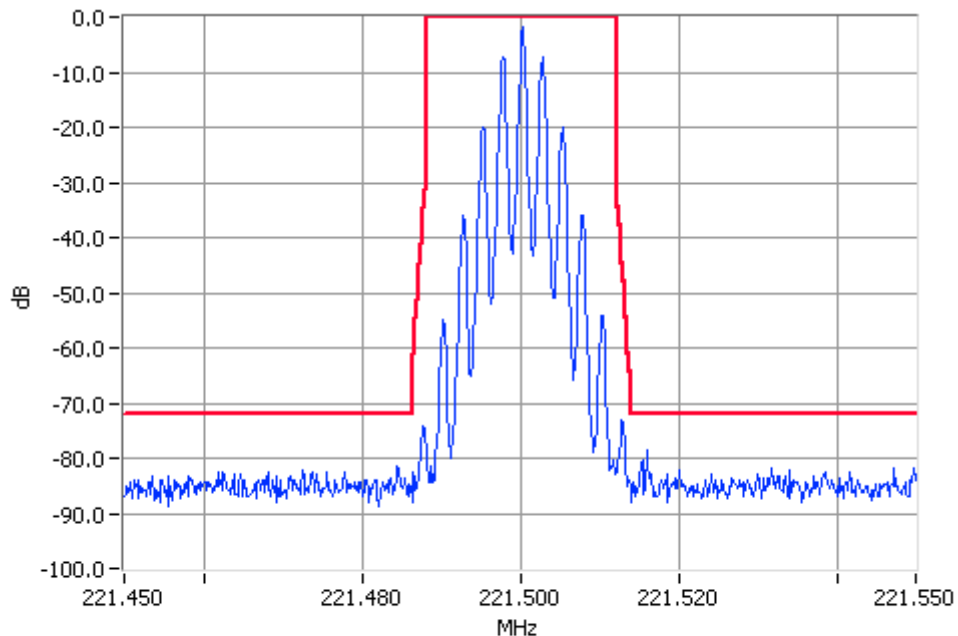

Analogue Modulation 221.5000MHz Mask Fx5 50W Pass
RBW=300Hz VBW=3000Hz

Analogue Voice : 12V DC PA

219.1 MHz Tx Power: 5W Channel Spacing: 12.5 kHz Mask: Fx5

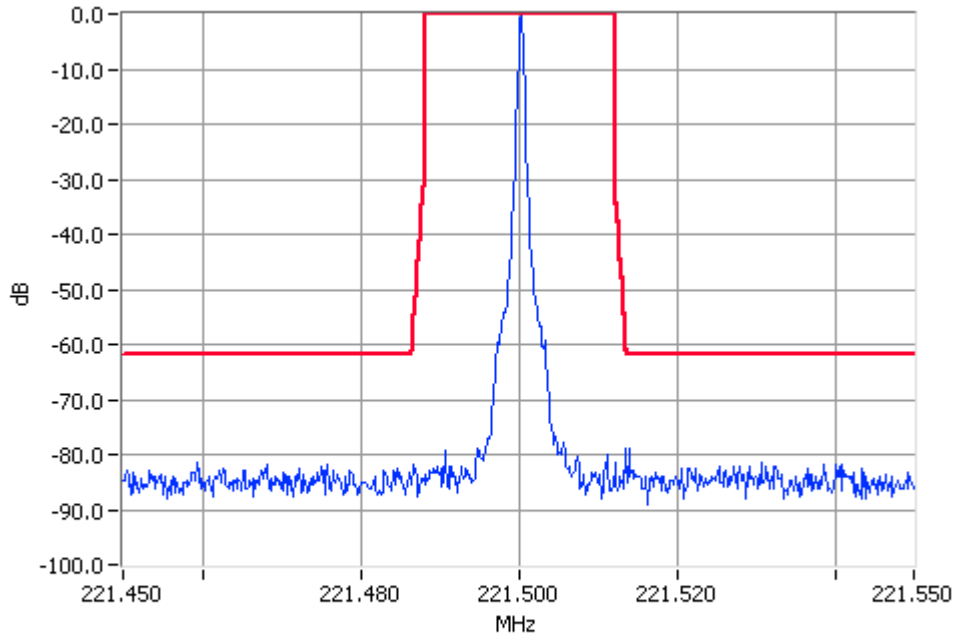

Unmodulated 221.5000MHz Mask Fx5 5W Pass
RBW=300Hz VBW=3000Hz

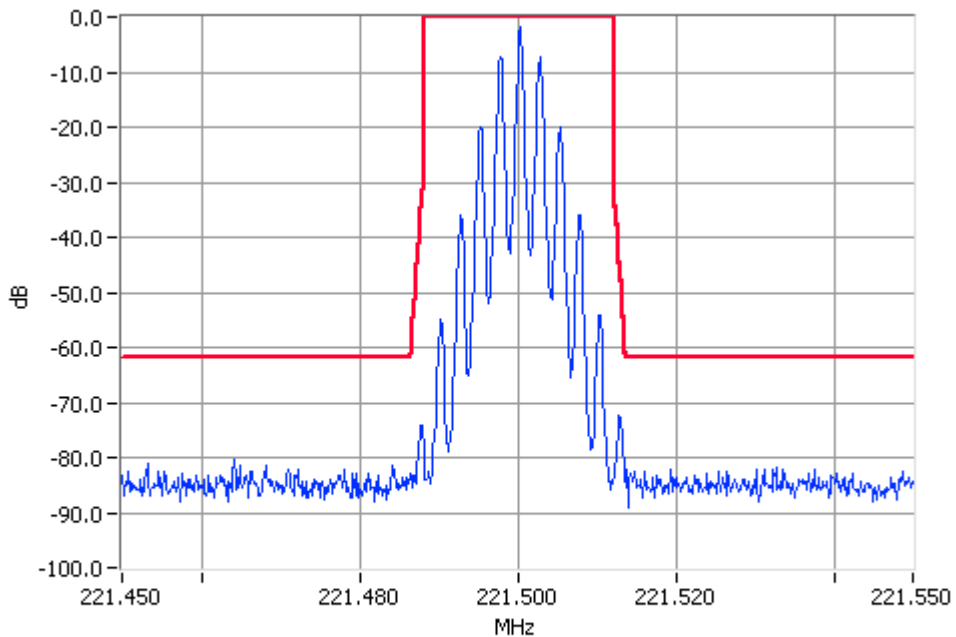

Analogue Modulation 221.5000MHz Mask Fx5 5W Pass
RBW=300Hz VBW=3000Hz

FFSK : 12V DC PA

219.1 MHz Tx Power: 50 W Channel Spacing: 12.5 kHz Mask: D

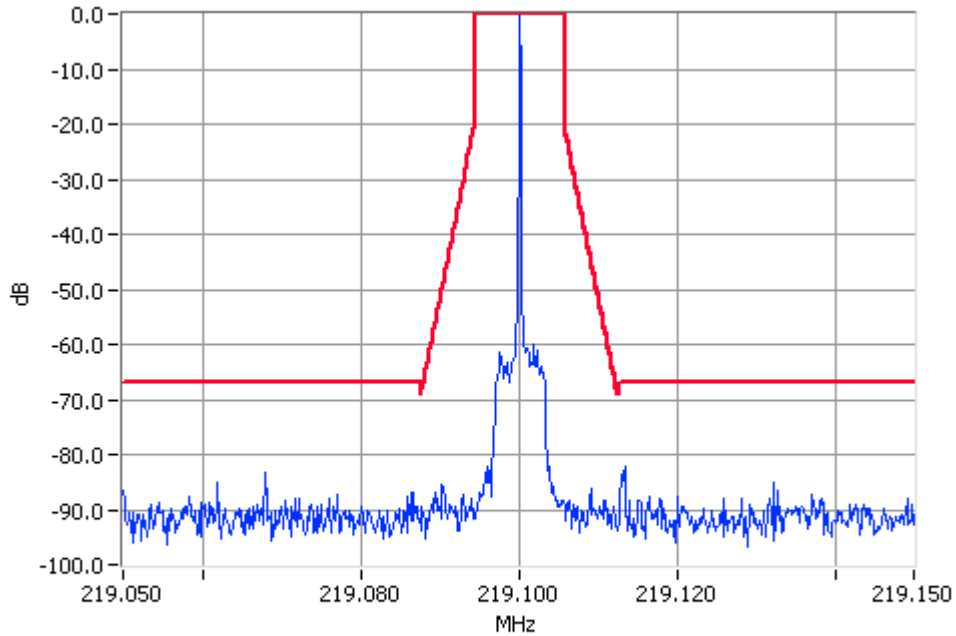

**Unmodulated 219.1000MHz Mask D 50W Pass
RBW=100Hz VBW=1000Hz**

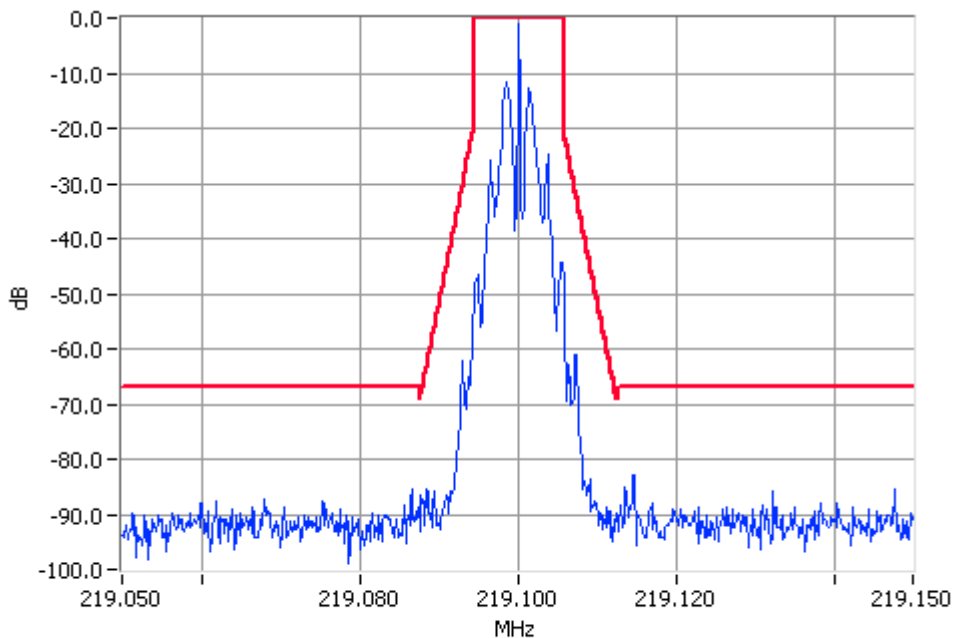

**Digital Modulation 219.1000MHz Mask D 50W Pass
RBW=100Hz VBW=1000Hz**

FFSK : 12V DC PA

219.1 MHz Tx Power: 5W Channel Spacing: 12.5 kHz Mask: D

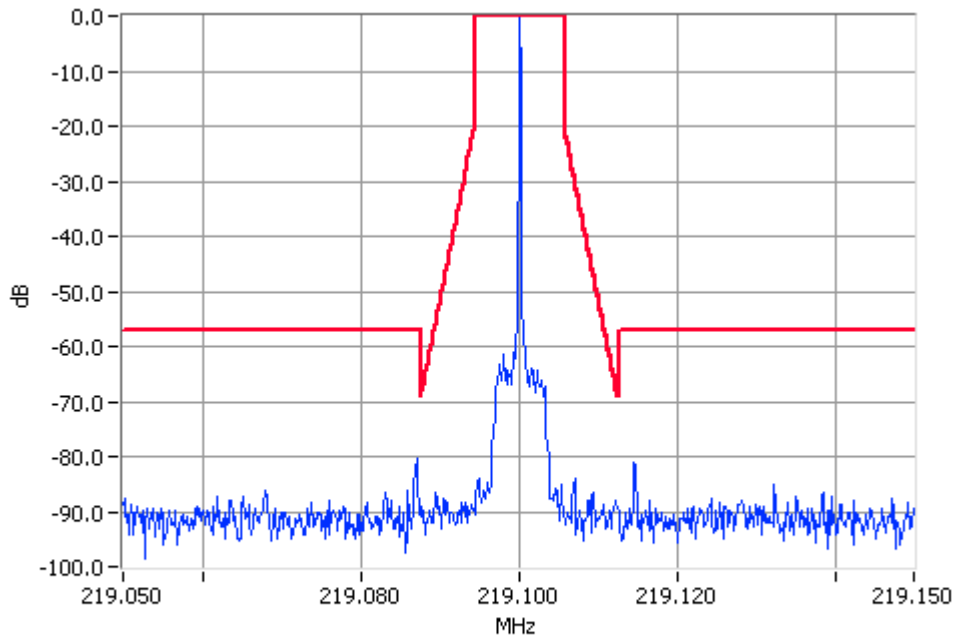

**Unmodulated 219.1000MHz Mask D 5W Pass
RBW=100Hz VBW=1000Hz**

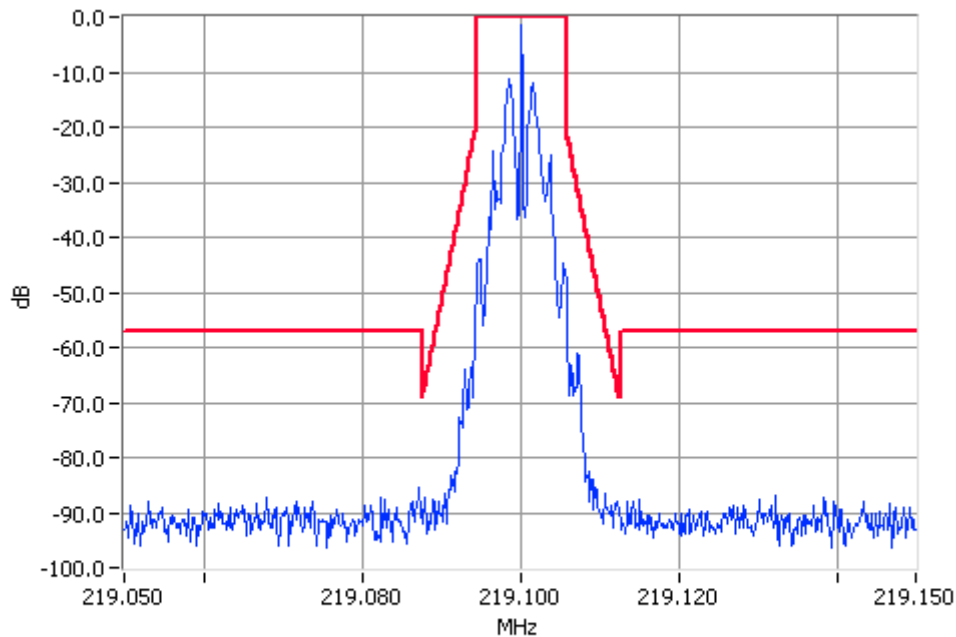

**Digital Modulation 219.1000MHz Mask D 5W Pass
RBW=100Hz VBW=1000Hz**

FFSK : 12V DC PA

221.5 MHz Tx Power: 50 W Channel Spacing: 12.5 kHz Mask: Fx5

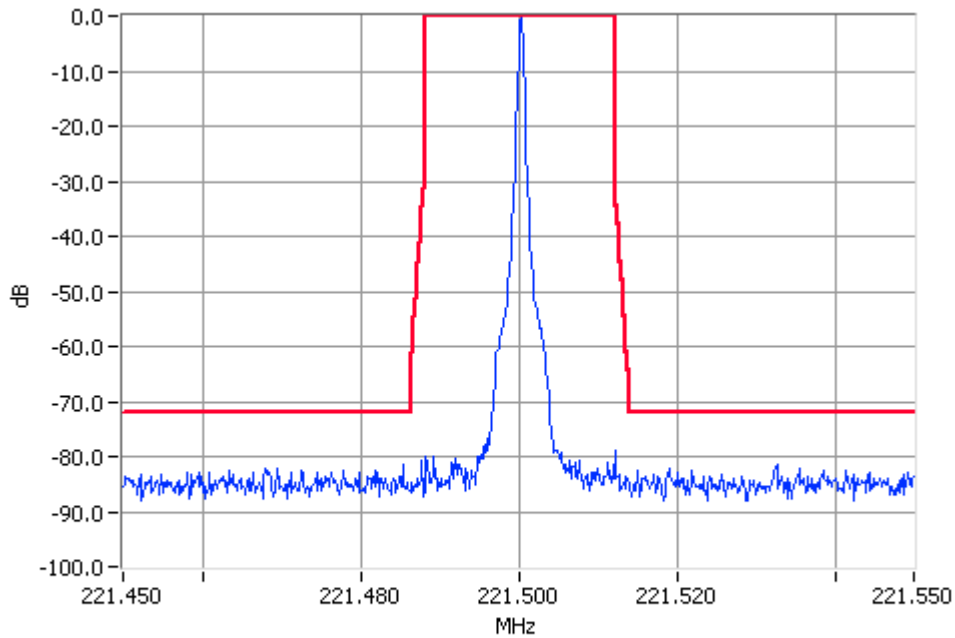

Unmodulated 221.500MHz Mask Fx5 50W Pass
RBW=300Hz VBW=3000Hz

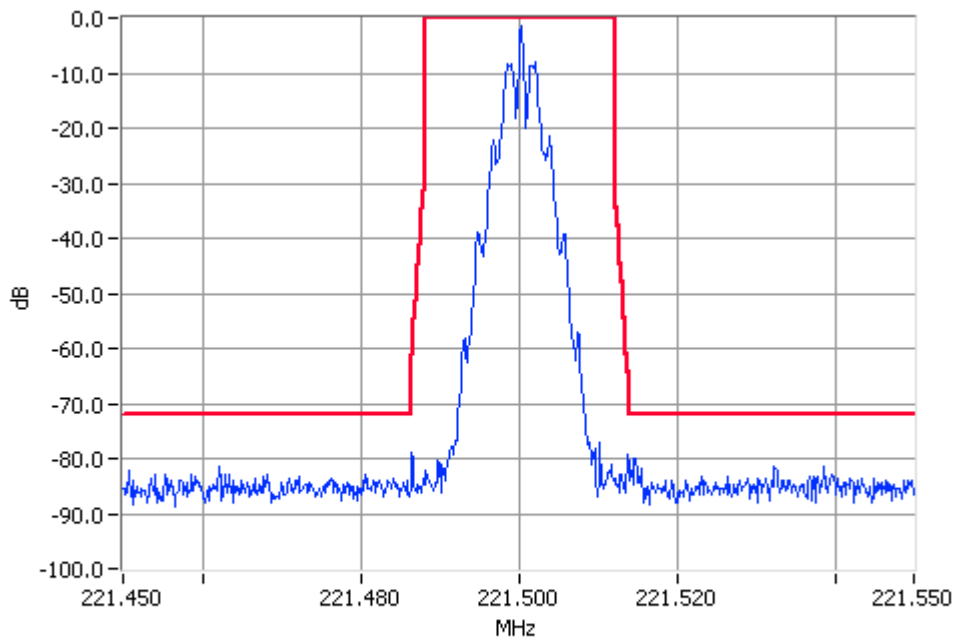

Digital Modulation 221.500MHz Mask Fx5 50W Pass
RBW=300Hz VBW=3000Hz

FFSK : 12V DC PA

221.5 MHz Tx Power: 5W Channel Spacing: 12.5 kHz Mask: Fx5

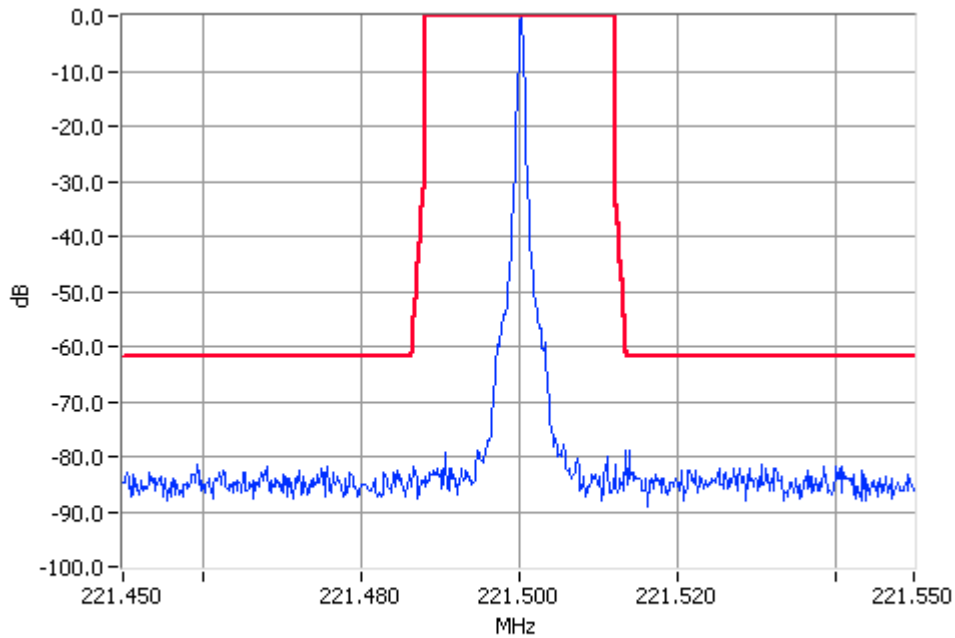

**Unmodulated 221.5000MHz Mask Fx5 5W Pass
RBW=300Hz VBW=3000Hz**

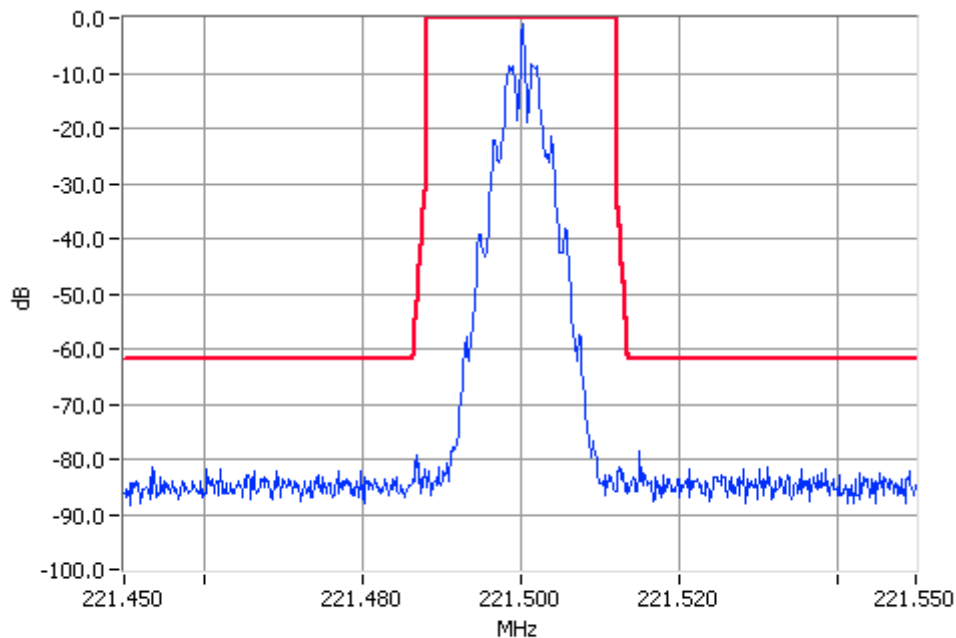

**Digital Modulation 221.5000MHz Mask Fx5 5W Pass
RBW=300Hz VBW=3000Hz**

Analogue Voice : 12V DC PA

219.1 MHz Tx Power: 50 W Channel Spacing: 25.0 kHz Mask: B

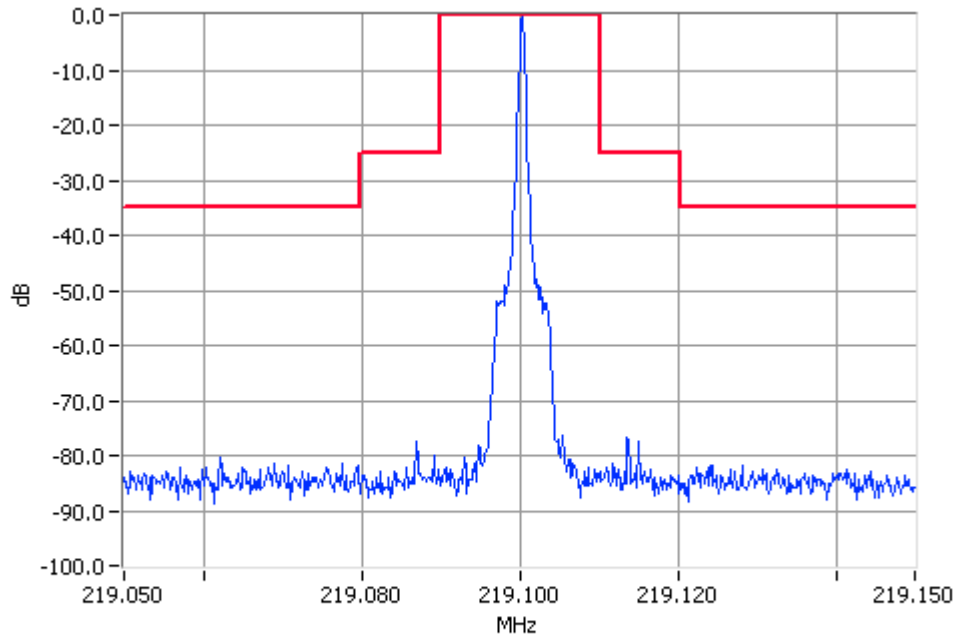

Unmodulated 219.100MHz Mask B 50W Pass
RBW=300Hz VBW=3000Hz

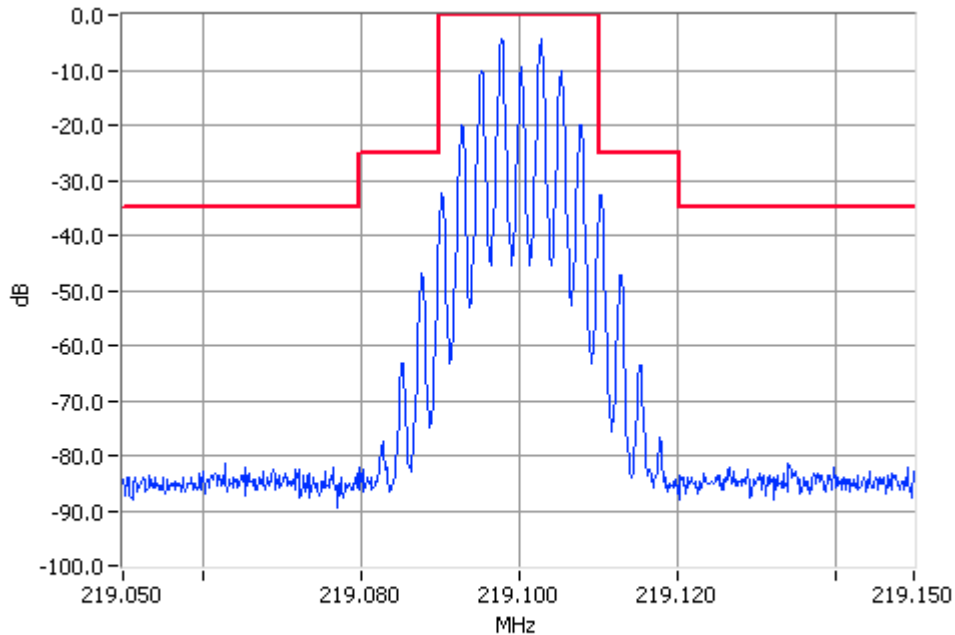

Analogue Modulation 219.100MHz Mask B 50W Pass
RBW=300Hz VBW=3000Hz

Analogue Voice : 12V DC PA

219.1 MHz Tx Power: 5W Channel Spacing: 25.0 kHz Mask: B

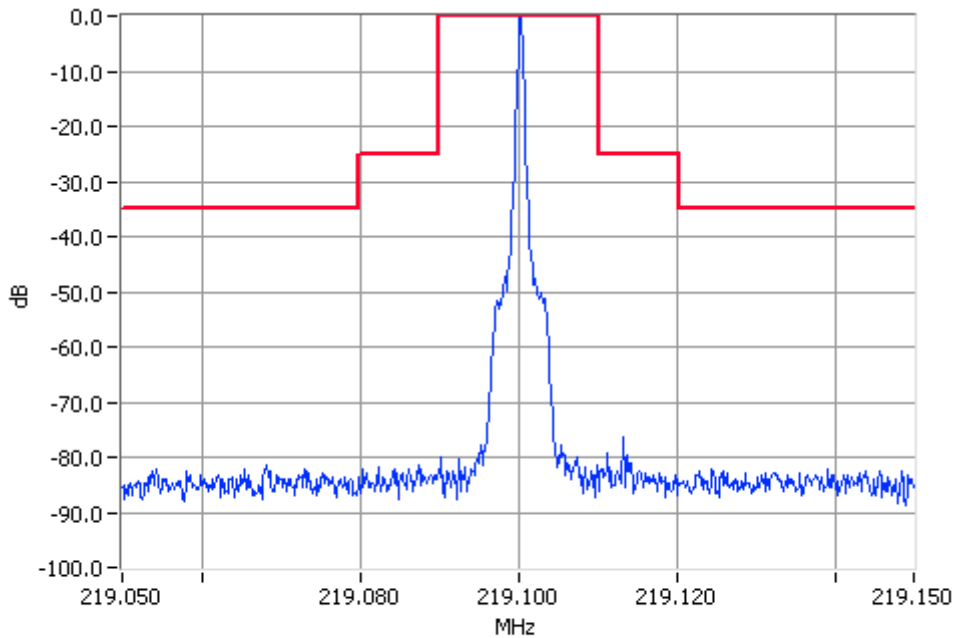

**Unmodulated 219.1000MHz Mask B 5W Pass
RBW=300Hz VBW=3000Hz**

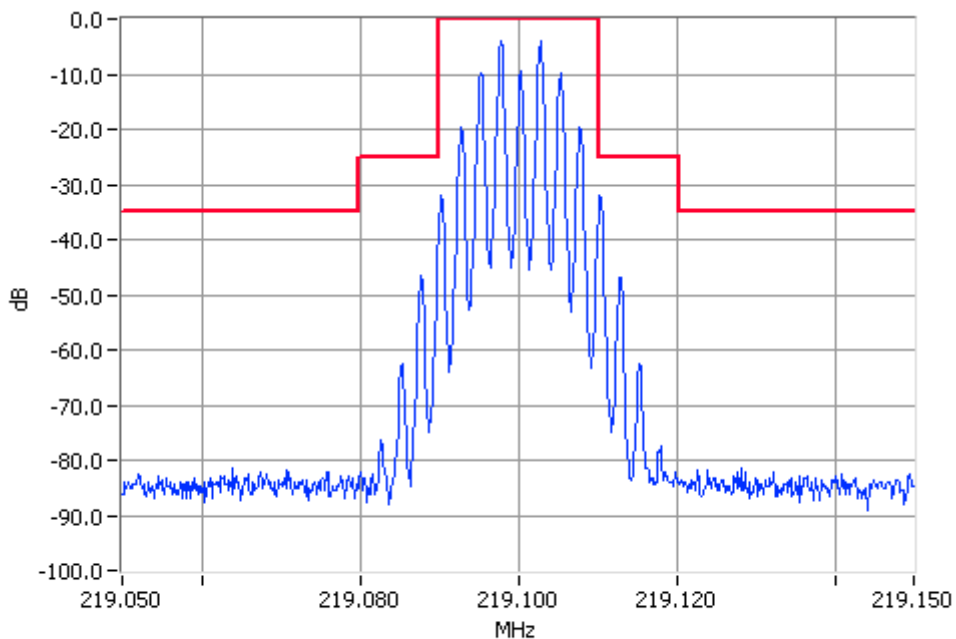

**Analogue Modulation 219.1000MHz Mask B 5W Pass
RBW=300Hz VBW=3000Hz**

FFSK : 12V DC PA

219.1 MHz Tx Power: 50 W Channel Spacing: 25.0 kHz Mask: C

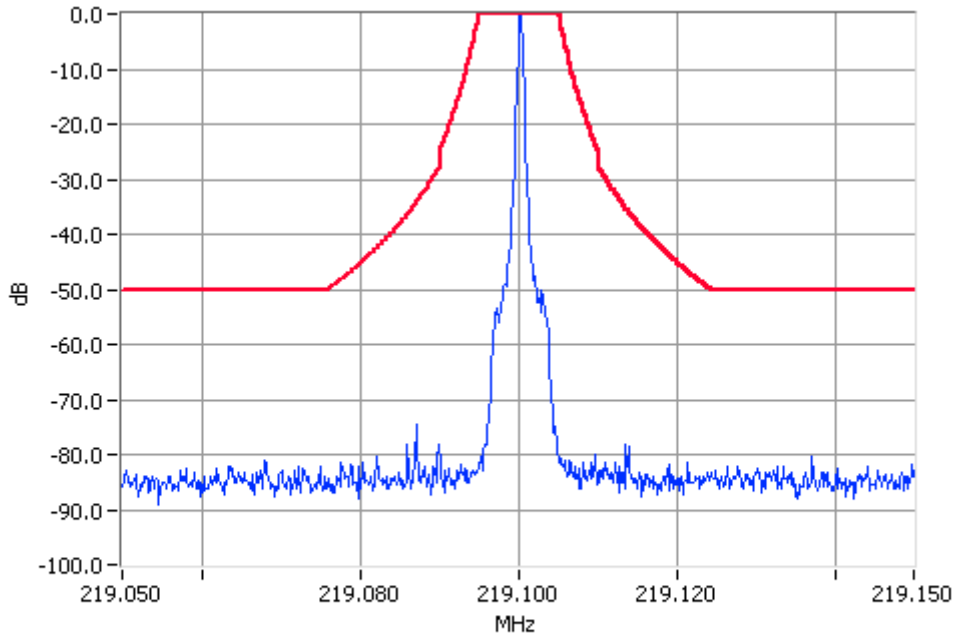

**Unmodulated 219.1000MHz Mask C 50W Pass
RBW=300Hz VBW=3000Hz**

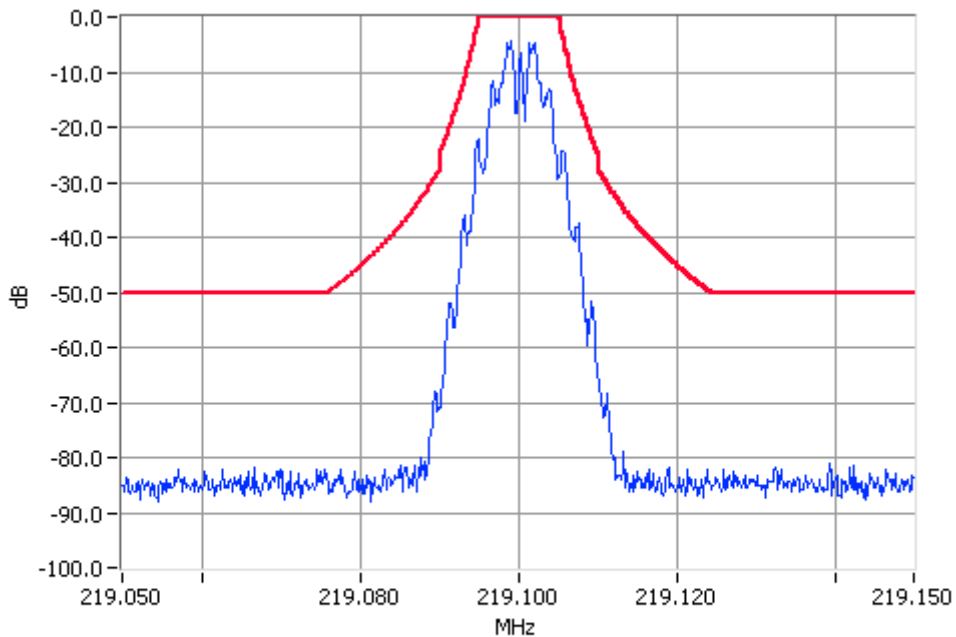

**Digital Modulation 219.1000MHz Mask C 50W Pass
RBW=300Hz VBW=3000Hz**

FFSK : 12V DC PA

219.1 MHz Tx Power: 5W Channel Spacing: 25.0 kHz Mask: C

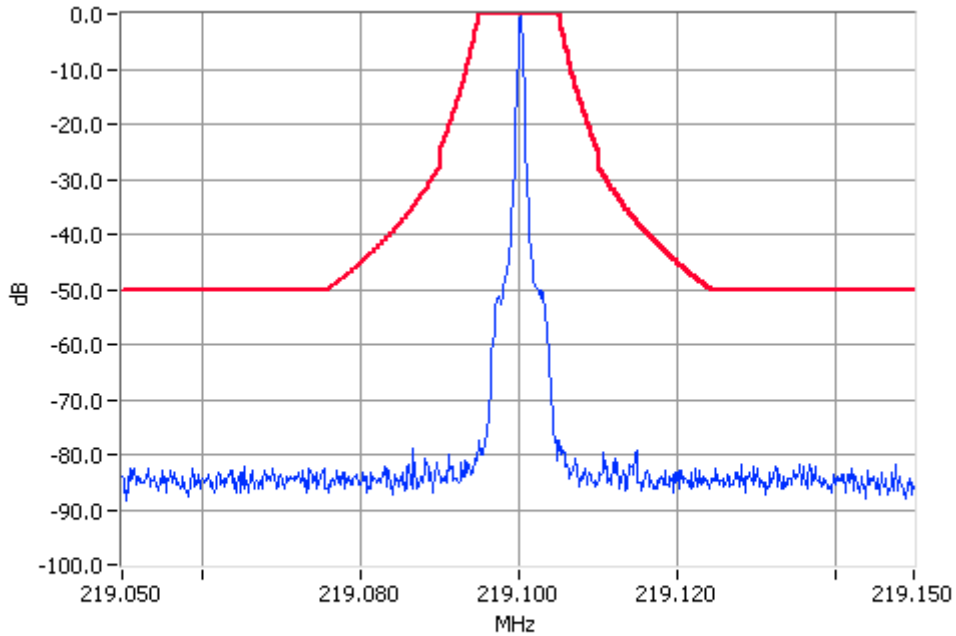

**Unmodulated 219.1000MHz Mask C 5W Pass
RBW=300Hz VBW=3000Hz**

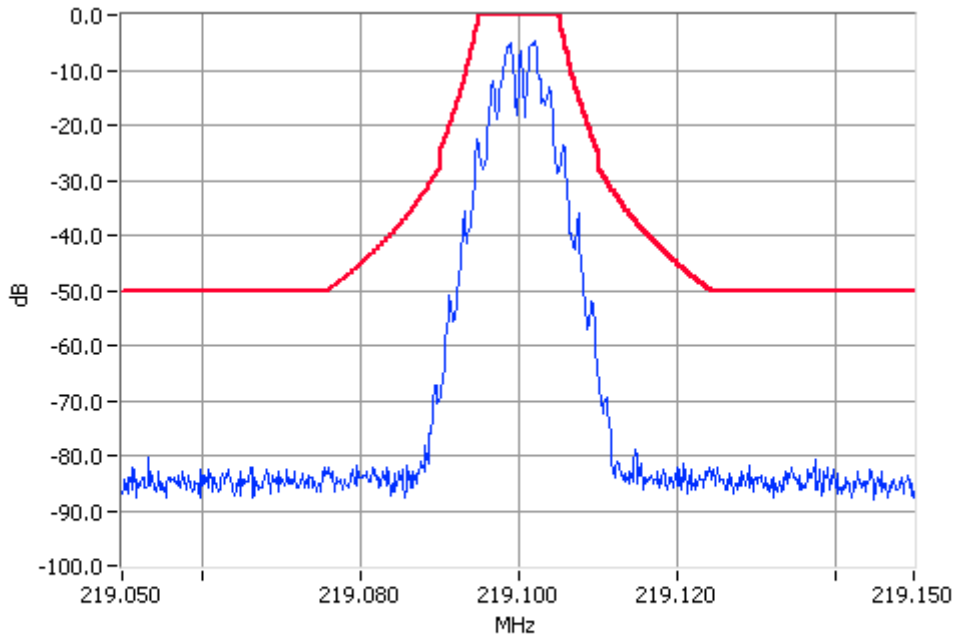

**Digital Modulation 219.1000MHz Mask C 5W Pass
RBW=300Hz VBW=3000Hz**

SPURIOUS EMISSIONS (CONDUCTED)

50W AC and DC Power Amplifier

SPECIFICATION: FCC 47 CFR 2.1051

GUIDE: TIA/EIA-603C 2.2.13

MEASUREMENT PROCEDURE:

1. Refer Annex A for equipment set up.
2. The frequency range examined was from the lowest frequency generated within the EUT, to a frequency higher than the 10th Harmonic: 100kHz to Fc-BW
Fc+BW to 2.2GHz
3. A Pre-scan is performed with a resolution bandwidth of 1 kHz, and a video bandwidth of 3 kHz. If any emissions are found to be within 20dB of the limit a second measurement is made with the carrier modulated, and a resolution bandwidth of 10 kHz, and a video bandwidth of 30kHz.
4. Spurious emissions which were attenuated more than 20dB below the limit were not recorded.

MEASUREMENT RESULTS:

See the tables on the following pages for 12.5 kHz & 25 kHz channel spacings.

LIMIT CLAUSE: FCC 47 CFR 90.210

MEASUREMENT UNCERTAINTY: +/-3.0 dB

SPURIOUS EMISSIONS (CONDUCTED)

50W AC and DC Power Amplifier

SPECIFICATION: FCC CFR 2.1051

Tx FREQUENCY: 219.1 MHz (Part 80)

12.5 kHz Channel Spacing	219.1 MHz @ 50 W	Emission Mask D
Emission Frequency (MHz)	Level (dBm)	Level (dBc)
Nil	Nil	Nil
No emissions were detected at a level greater than 20 dB below the limit.		

12.5 kHz Channel Spacing	219.1 MHz @ 5 W	Emission Mask D
Emission Frequency (MHz)	Level (dBm)	Level (dBc)
Nil	Nil	Nil
No emissions were detected at a level greater than 20 dB below the limit.		

LIMITS:

Carrier Output Power Watts	Emission Mask D 12.5 kHz Channel Spacing $50 + 10 \text{ Log}_{10} (P_{\text{Watts}})$	
50 W	-20 dBm	67 dBc
5 W	-20 dBm	57 dBc

SPURIOUS EMISSIONS (CONDUCTED)

50W AC and DC Power Amplifier

SPECIFICATION: FCC CFR 2.1051

Tx FREQUENCY: 221.5 MHz (Part 90T)

12.5 kHz Channel Spacing	221.5 MHz @ 50 W	Emission Mask F
Emission Frequency (MHz)	Level (dBm)	Level (dBc)
Nil	Nil	Nil
No emissions were detected at a level greater than 20 dB below the limit.		

12.5 kHz Channel Spacing	221.5 MHz @ 5 W	Emission Mask F
Emission Frequency (MHz)	Level (dBm)	Level (dBc)
Nil	Nil	Nil
No emissions were detected at a level greater than 20 dB below the limit.		

LIMITS:

Carrier Output Power Watts	Emission Mask F 5.0 kHz Channel Spacing $55 + 10 \text{ Log}_{10} (P_{\text{Watts}})$	
50 W	-25 dBm	72 dBc
5 W	-25 dBm	62 dBc

SPURIOUS EMISSIONS (RADIATED)

50W 120VAC and 12VDC Power Amplifier

SPECIFICATION: FCC 47 CFR 2.1053

GUIDE: TIA/EIA-603C 2.2.12

MEASUREMENT PROCEDURE:

1. Refer Annex A for Equipment set up.
2. Initial Scan
 - a) The EUT is placed in S-Line TEM cell and emissions are measured from 30MHz to 1000MHz.
Any emission within 10dB of the limit is then re-tested on the OATS along with measurements from 1000MHz to the 10th harmonic of the fundamental frequency.
3. OATS Measurement
 - a) The EUT was placed on a wooden turntable at a distance of three metres from the test antenna. The output terminal was connected to an RF dummy load.
 - b) The test antenna was raised from 1m to 4m to obtain a maximum reading, the turntable was then rotated through 360° to obtain the maximum response of each spurious emission. Valid emissions were determined by switching the EUT on and off.
 - c) The EUT was then replaced by a signal generator and substitution antenna to make measurements by the substitution method.

MEASUREMENT RESULTS:

See the tables on the following pages

LIMIT CLAUSE: FCC 47 CFR 90.210

MEASUREMENT UNCERTAINTY: +/-4.6 dB

SPURIOUS EMISSIONS (RADIATED)

50W 120VAC and 12VDC Power Amplifier

SPECIFICATION: FCC CFR 2.1053

Tx FREQUENCY: 219.1 MHz (Part 80)

12.5 kHz Channel Spacing		219.1 MHz @ 50 W	Emission Mask D
Emission Frequency (MHz)	Level (dBm)		Level (dBc)
~	~		~
No emissions were detected at a level greater than 20 dB below the limit.			

Tx FREQUENCY: 219.1 MHz (Part 80)

12.5 kHz Channel Spacing		219.1 MHz @ 5 W	Emission Mask D
Emission Frequency (MHz)	Level (dBm)		Level (dBc)
~	~		~
No emissions were detected at a level greater than 20 dB below the limit.			

LIMITS:

Carrier Output Power Watts	Emission Mask D 12.5 kHz Channel Spacing $50 + 10 \text{ Log}_{10} (P_{\text{Watts}})$	
50 W	-20 dBm	67 dBc
5 W	-20 dBm	57 dBc

SPURIOUS EMISSIONS (RADIATED)

50W 120VAC and 12VDC Power Amplifier

SPECIFICATION: FCC CFR 2.1053

Tx FREQUENCY: 221.5 MHz (Part 90T)

12.5 kHz Channel Spacing	221.5 MHz @ 50 W	Emission Mask F
Emission Frequency (MHz)	Level (dBm)	Level (dBc)
~	~	~
No emissions were detected at a level greater than 20 dB below the limit.		

Tx FREQUENCY: 221.5 MHz (Part 90T)

12.5 kHz Channel Spacing	221.5 MHz @ 5 W	Emission Mask F
Emission Frequency (MHz)	Level (dBm)	Level (dBc)
~	~	~
No emissions were detected at a level greater than 20 dB below the limit.		

LIMITS:

Carrier Output Power Watts	Emission Mask F 12.5 kHz Channel Spacing $55 + 10 \text{ Log}_{10} (P_{\text{Watts}})$	
50 W	-25 dBm	72 dBc
5 W	-25 dBm	62 dBc

TRANSMITTER FREQUENCY STABILITY (TEMPERATURE)

SPECIFICATION: FCC 47 CFR 2.1055 (a) (1)

GUIDE: TIA/EIA-603C 2.2.2

MEASUREMENT PROCEDURE:

1. Refer Annex A for equipment set up.
2. The EUT was tested for frequency error from -30°C to $+50^{\circ}\text{C}$ in 10°C increments
3. The frequency error was recorded in parts per million (ppm).

MEASUREMENT RESULTS:

See the plots on the following pages for 12.5 kHz & 25 kHz channel spacings for the:

50W 120V AC Power Amplifier

Limit Clause : FCC 47 CFR 80.209	
Frequency Range (MHz)	Frequency Error (ppm)
216-220	5.0
Limit Clause : FCC 47 CFR 90.213	
Frequency Range (MHz)	Frequency Error (ppm)
216-220	1.0
220-222	0.1
Manufacturer's Claimed Stability	0.5

Transmit frequency: 219.1 MHz 50W Channel Spacing 25.0kHz

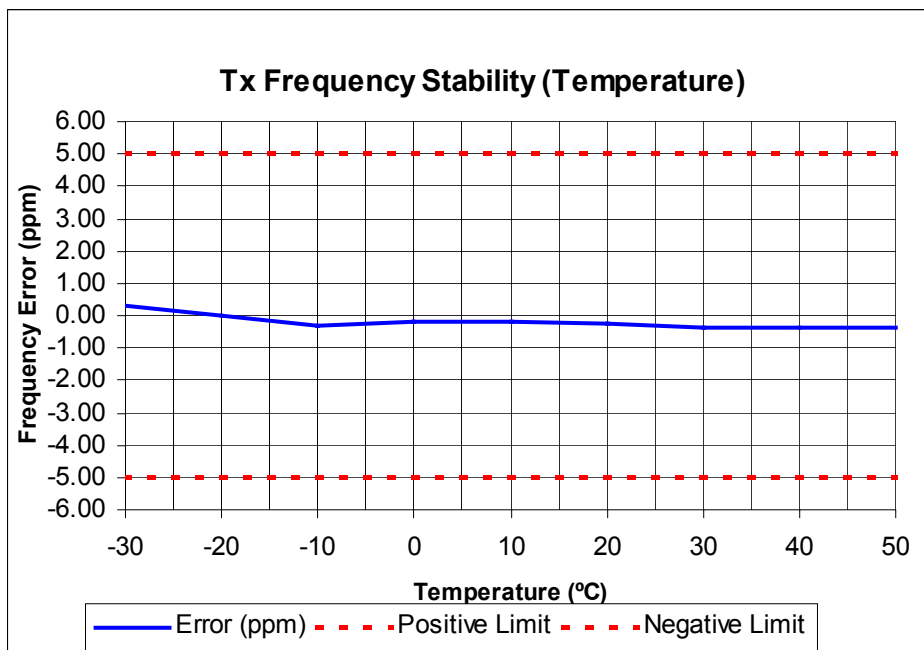

Measurement Uncertainty	+/- 50 Hz
-------------------------	-----------

TRANSMITTER FREQUENCY STABILITY (TEMPERATURE)

SPECIFICATION: FCC 47 CFR 2.1055 (a) (1)

Tx FREQUENCY: 221.5 MHz 50 W 12.5 kHz channel Spacing

(EUT Internal Frequency Reference)

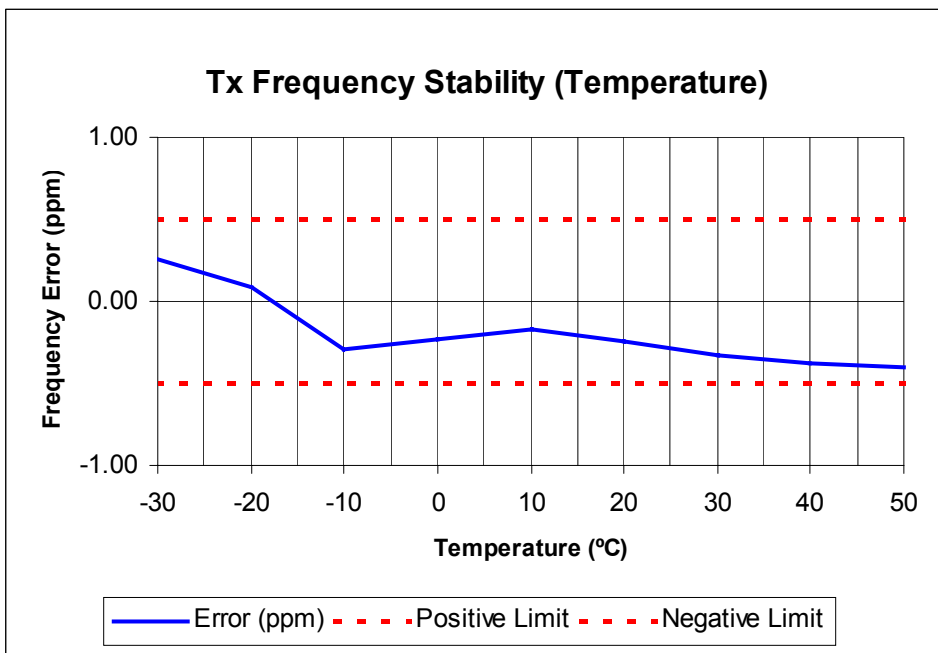

Tx FREQUENCY: 221.5 MHz 50 W 12.5 kHz channel Spacing

(External 10MHz Frequency Reference T801-20-000)

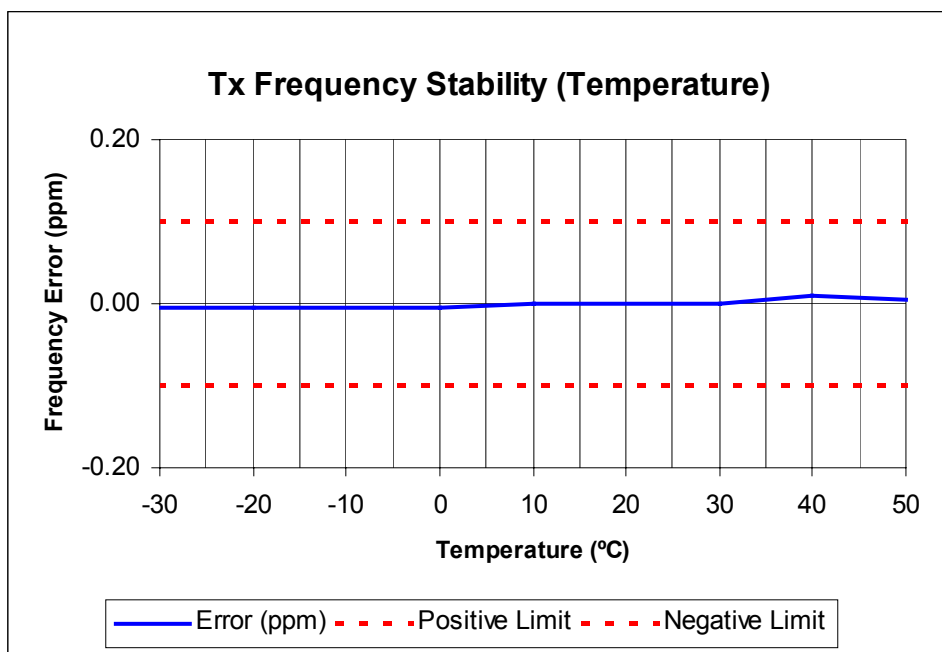

Measurement Uncertainty	+/- 50 Hz
-------------------------	-----------

TELTEST Laboratories
Tait Electronics Limited
Report Number 2470

TRANSMITTER FREQUENCY STABILITY (VOLTAGE)

SPECIFICATION: FCC 47 CFR 2.1055 (d) (1)

GUIDE: TIA/EIA-603C 2.2.2

MEASUREMENT PROCEDURE:

1. Refer Annex A for equipment set up.
2. The EUT was tested for frequency error at an input voltage to the radio of 85% to 115%.
3. The frequency error was recorded in parts per million (ppm).

MEASUREMENT RESULTS (AC): FCC 47 CFR 80.209

Frequency	FREQUENCY ERROR (ppm) @ 219.1 MHz		
	102 V AC	120 V AC	138 V AC
216 MHz ~ 220 MHz	-0.26	-0.25	-0.26

MEASUREMENT RESULTS (AC): FCC 47 CFR 90.213

Frequency	FREQUENCY ERROR (ppm) @ 221.5 MHz		
	102 V AC	120 V AC	138 V AC
EUT Internal Frequency Reference	-0.27	-0.27	-0.27
External 10MHz Frequency Reference T801-20-000	-0.02	-0.02	-0.02

MEASUREMENT RESULTS (DC): FCC 47 CFR 80.209

Frequency	FREQUENCY ERROR (ppm) @ 219.1 MHz		
	11.7V DC	13.2V DC	15.9V DC
216 MHz ~ 220 MHz	-0.29	-0.28	-0.29

MEASUREMENT RESULTS (DC): FCC 47 CFR 90.213

Frequency	FREQUENCY ERROR (ppm) @ 221.5 MHz		
	11.7V DC	13.2V DC	15.9V DC
EUT Internal Frequency Reference	-0.30	-0.29	-0.30
External 10MHz Frequency Reference T801-20-000	-0.05	-0.05	-0.05

Limit Clause:	FCC 47 CFR 80.209		
Frequency Range (MHz)	Frequency Error (ppm)		
216-220	5.0		
Limit Clause:	FCC 47 CFR 90.213		
Frequency Range (MHz)	Frequency Error (ppm)		
216-220	1.0		
220-222	0.1		
220-222 Manufacturers Claimed Stability	0.5		
Measurement Uncertainty	+/- 50 Hz		

TELTEST Laboratories
Tait Electronics Limited
Report Number 2470

TEST EQUIPMENT USED

No#	Equipment	Manufacturer	Model No	Serial No#	Tait ID	Cal Due
1	Signal Generator	Hewlett Packard	HP8642B (Opt 001)	2512A00176	E3064	26-Nov-06
5	Signal Generator	Rohde & Schwarz	SMY01 1062.5502.11	841736/019	E3553	26-Nov-06
11	Modulation Analyser	Hewlett Packard	HP8901B (Opt 002)	2441A00393	E3073	26-Nov-06
13	Audio Analyser	Hewlett Packard	HP8903A	2308A02597	E3074	28-Nov-06
20	Power Supply	Hewlett Packard	HP6032A	2441A00412	E3075	26-Nov-06
21	Power Supply	Rohde & Schwarz	NGS M32/10 192.0810.31	Fnr 434	E3556	26-Sep-06
22	Oscilloscope	Tektronics	TDS340	B013611	E3585	26-Nov-06
24	Environ. Chamber	Contherm	Spatial Cal	E3397	E3397	
24	Environ. Chamber	Contherm	Temp Control	E3397	E3397	
40	Reference Dipoles	Emco	3121C DB1	9510-1164	E3559	17-Oct-06
43	Horn Antenna	Emco	DRG3115	2084	E3076	27-Sep-06
46	S-LINE TEM CELL	Rohde & Schwarz	1089.9296.02	338232/003	E3636	
52	Amplifier +21.7 dB	Tait	ZFL-1000LN	E3660	E3360	
70	RF Load 150W	Bird	8166	524	E3625	28-Nov-06
87	Audio Analyser	Hewlett Packard	HP8903B	2818A04275	E3710	23-Nov-06
88	Spectrum Analyser	Hewlett Packard	HP8562E	3821A00779	E3715	25-Nov-06
100	Oscilloscope	Tektronics	TDS380	B017095	E3782	25-Nov-06
123	Spectrum Analyser	Agilent	E4445A	MY42510072	E4139	4-Jul-07
135	Attenuator	Weinschel	67-30-33	BR0531	E4280	26-Nov-06
137	1m Multiflex Cable	Suhner	MF141	TT007	E4443	25-Nov-06
138	1m Multiflex Cable	Suhner	MF141	TT086	E4444	25-Nov-06
144	AC Voltmeter	Tait				5-Apr-07
145	AC Voltmeter	Tait				10-Apr-07

ANNEX A

TEST SETUP DETAILS

Radiated Emissions Set up.

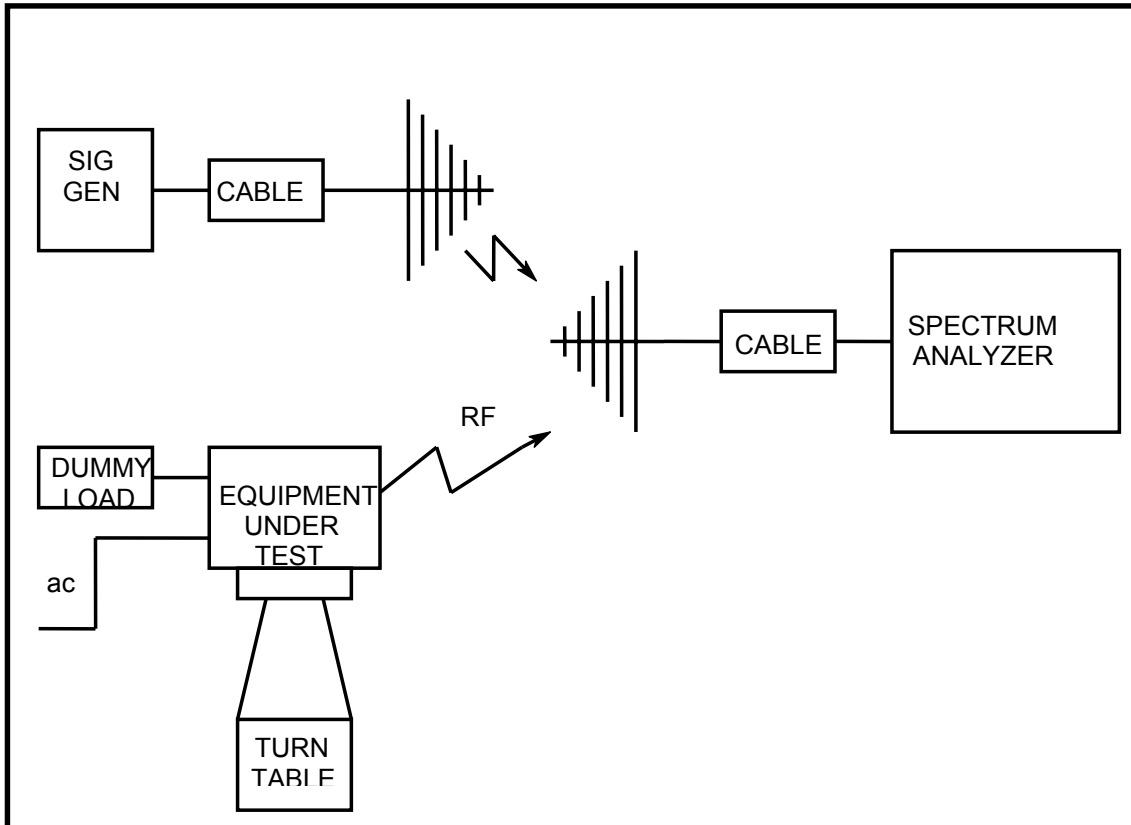

The Spectrum Analyser is connected to the EUT via a 30dB attenuator for Conducted Emissions testing.
For Transmitter Unwanted Emissions testing, the Spectrum Analyser is connected to the combiner in place of Signal Generator 3.

