



CERTIFICATION TEST REPORT

Report Number. : 12122325-E3V2

Applicant : SRAM LLC
1000 W Fulton Market 4th Floor
Chicago, IL 60607 U.S.A

Model : 13200

FCC ID : C9O-SPMB1

IC : 1016A-SPMB1

EUT Description : Bicycle Seatpost with AIREA, BLE and ANT+ Radios

Test Standard(s) : FCC 47 CFR PART 15 SUBPART C
ISED RSS-210 ISSUE 9
ISED RSS-GEN ISSUE 5

Date Of Issue:
October 23, 2018

Prepared by:
UL Verification Services Inc.
47173 Benicia Street
Fremont, CA 94538, U.S.A.
TEL: (510) 771-1000
FAX: (510) 661-0888



REPORT REVISION HISTORY

Rev.	Issue Date	Revisions	Revised By
V1	10/10/2018	Initial Issue	
V2	10/24/2018	Updated Cover Page, Section 1 and Section 2	Steven Tran

TABLE OF CONTENTS

REPORT REVISION HISTORY	2
TABLE OF CONTENTS	3
1. ATTESTATION OF TEST RESULTS	4
2. TEST METHODOLOGY	5
3. FACILITIES AND ACCREDITATION	5
4. CALIBRATION AND UNCERTAINTY	6
4.1. <i>MEASURING INSTRUMENT CALIBRATION</i>	<i>6</i>
4.2. <i>SAMPLE CALCULATION</i>	<i>6</i>
4.3. <i>MEASUREMENT UNCERTAINTY.....</i>	<i>6</i>
5. EQUIPMENT UNDER TEST.....	7
5.1. <i>DESCRIPTION OF EUT</i>	<i>7</i>
5.2. <i>MAXIMUM OUTPUT FUNDAMENTAL FIELD STRENGTH.....</i>	<i>7</i>
5.3. <i>DESCRIPTION OF AVAILABLE ANTENNAS</i>	<i>7</i>
5.4. <i>SOFTWARE AND FIRMWARE.....</i>	<i>7</i>
5.5. <i>WORST-CASE CONFIGURATION AND MODE.....</i>	<i>7</i>
5.6. <i>DESCRIPTION OF TEST SETUP.....</i>	<i>8</i>
6. MEASUREMENT METHOD.....	10
7. TEST AND MEASUREMENT EQUIPMENT	11
8. ANTENNA PORT TEST RESULTS	12
8.1. <i>ON TIME AND DUTY CYCLE.....</i>	<i>12</i>
8.2. <i>99% BANDWIDTH.....</i>	<i>13</i>
8.3. <i>20dB BANDWIDTH.....</i>	<i>14</i>
9. RADIATED TEST RESULTS.....	16
9.1. <i>TRANSMITTER ABOVE 1 GHz.....</i>	<i>18</i>
9.2. <i>FUNDAMENTAL FREQUENCY RADIATED EMISSION.....</i>	<i>28</i>
9.3. <i>Worst Case Below 30MHz</i>	<i>29</i>
9.4. <i>Worst Case Below 1 GHz</i>	<i>31</i>
9.5. <i>Worst Case 18-26 GHz.....</i>	<i>33</i>
10. SETUP PHOTOS	35

1. ATTESTATION OF TEST RESULTS

COMPANY NAME: SRAM LLC
1000 W Fulton Market 4th Floor
Chicago, IL 60607 U.S.A

EUT DESCRIPTION: Bicycle Seatpost with AIREA, BLE and ANT+ Radios

MODEL: 13200

SERIAL NUMBER: 1514030014 (Conducted); 1514030015 (Radiated)

DATE TESTED: January 17th, 2018 – June 6th, 2018

APPLICABLE STANDARDS	
STANDARD	TEST RESULTS
CFR 47 Part 15 Subpart C	Complies
ISED RSS-210 Issue 9	Complies
ISED RSS-GEN Issue 5	Complies

UL Verification Services Inc. tested the above equipment in accordance with the requirements set forth in the above standards. All indications of Pass/Fail in this report are opinions expressed by UL Verification Services Inc. based on interpretations and/or observations of test results. Measurement Uncertainties were not taken into account and are published for informational purposes only. The test results show that the equipment tested is capable of demonstrating compliance with the requirements as documented in this report.

Note: The results documented in this report apply only to the tested sample, under the conditions and modes of operation as described herein. This document may not be altered or revised in any way unless done so by UL Verification Services Inc. and all revisions are duly noted in the revisions section. Any alteration of this document not carried out by UL Verification Services Inc. will constitute fraud and shall nullify the document. This report must not be used by the client to claim product certification, approval, or endorsement by NVLAP, NIST, any agency of the Federal Government, or any agency of the U.S. government.

Approved & Released For
UL Verification Services Inc. By:

Reviewed By:



DAN CORONIA
CONSUMER TECHNOLOGY DIVISION
OPERATIONS LEADER
UL Verification Services Inc.

STEVEN TRAN
CONSUMER TECHNOLOGY DIVISION
PROJECT ENGINEER
UL Verification Services Inc.

2. TEST METHODOLOGY

The tests documented in this report were performed in accordance with FCC CFR 47 Part 2, FCC CFR 47 Part 15, ANSI C63.10-2013, RSS-GEN Issue 5, and RSS-247 Issue 2.

3. FACILITIES AND ACCREDITATION

The test sites and measurement facilities used to collect data are located at 47173 and 47266 Benicia Street, and 47658 Kato Road, Fremont, California, USA. Line conducted emissions are measured only at the 47173 address. The following table identifies which facilities were utilized for radiated emission measurements documented in this report. Specific facilities are also identified in the test results sections.

47173 Benicia Street	47266 Benicia Street	47658 Kato Rd.
<input checked="" type="checkbox"/> Chamber A (IC:2324B-1)	<input checked="" type="checkbox"/> Chamber D (IC:22541-1)	<input type="checkbox"/> Chamber I (IC: 2324A-5)
<input checked="" type="checkbox"/> Chamber B (IC:2324B-2)	<input type="checkbox"/> Chamber E (IC:22541-2)	<input type="checkbox"/> Chamber J (IC: 2324A-6)
<input type="checkbox"/> Chamber C (IC:2324B-3)	<input checked="" type="checkbox"/> Chamber F (IC:22541-3)	<input type="checkbox"/> Chamber K (IC: 2324A-1)
	<input type="checkbox"/> Chamber G (IC:22541-4)	<input type="checkbox"/> Chamber L (IC: 2324A-3)
	<input type="checkbox"/> Chamber H (IC:22541-5)	

The above test sites and facilities are covered under FCC Test Firm Registration # 208313. Chambers above are covered under Industry Canada company address and respective code.

UL Verification Services Inc. is accredited by NVLAP, Laboratory Code 200065-0

4. CALIBRATION AND UNCERTAINTY

4.1. MEASURING INSTRUMENT CALIBRATION

The measuring equipment utilized to perform the tests documented in this report has been calibrated in accordance with the manufacturer's recommendations, and is traceable to recognized national standards.

4.2. SAMPLE CALCULATION

Where relevant, the following sample calculation is provided:

$$\begin{aligned} \text{Field Strength (dBuV/m)} &= \text{Measured Voltage (dBuV)} + \text{Antenna Factor (dB/m)} + \\ &\text{Cable Loss (dB)} - \text{Preamp Gain (dB)} \\ 36.5 \text{ dBuV} + 18.7 \text{ dB/m} + 0.6 \text{ dB} - 26.9 \text{ dB} &= 28.9 \text{ dBuV/m} \end{aligned}$$

4.3. MEASUREMENT UNCERTAINTY

Where relevant, the following measurement uncertainty levels have been estimated for tests performed on the apparatus:

PARAMETER	UNCERTAINTY
Worst Case Conducted Disturbance, 9KHz to 0.15 MHz	3.84 dB
Worst Case Conducted Disturbance, 0.15 to 30 MHz	3.65 dB
Worst Case Radiated Disturbance, 9KHz to 30 MHz	3.15 dB
Worst Case Radiated Disturbance, 30 to 1000 MHz	5.36 dB
Worst Case Radiated Disturbance, 1000 to 18000 MHz	4.32 dB
Worst Case Radiated Disturbance, 18000 to 26000 MHz	4.45 dB
Worst Case Radiated Disturbance, 26000 to 40000 MHz	5.24 dB

Uncertainty figures are valid to a confidence level of 95%.

5. EQUIPMENT UNDER TEST

5.1. DESCRIPTION OF EUT

The EUT is a Bicycle Seatpost with AIREA, BLE and ANT+ Radios.

5.2. MAXIMUM OUTPUT FUNDAMENTAL FIELD STRENGTH

The transmitter has a maximum peak fundamental field strength as follows:

Frequency Range (MHz)	Mode	Peak E-field Strength (dBuV/m)	Avg E-field Strength (dBuV/m)	Distance (m)
2405 - 2475	ANT +	92.54	92.01	3.00

5.3. DESCRIPTION OF AVAILABLE ANTENNAS

The radio utilizes a chip antenna, with a maximum gain of -2 dBi.

5.4. SOFTWARE AND FIRMWARE

The EUT firmware installed during testing was A-1.0.
The test utility software used during testing was Lightblue v2.6.4

5.5. WORST-CASE CONFIGURATION AND MODE

Radiated emissions below 1GHz and above 18GHz were performed with the EUT set to transmit at the channel with highest output power as worst-case scenario.

Band edge and radiated emissions between 1GHz and 18GHz were performed with the EUT set to transmit at the highest power on low, middle and high channels.

The fundamental of the EUT was investigated in three orthogonal orientations X, Y, Z, it was determined that Y orientation was worst-case orientation; therefore, all final radiated testing was performed with the EUT in Y orientation.

5.6. DESCRIPTION OF TEST SETUP

SUPPORT EQUIPMENT

Support Equipment List			
Description	Manufacturer	Model	Serial Number
Ipod Touch	Apple	MKJ02LL/A	CCQVRHY2GGNL

TEST SETUP

The EUT is powered by a dummy battery with a DC power supply. The iPod Touch wirelessly sends commands to the EUT.

SETUP DIAGRAM FOR CONDUCTED TESTS

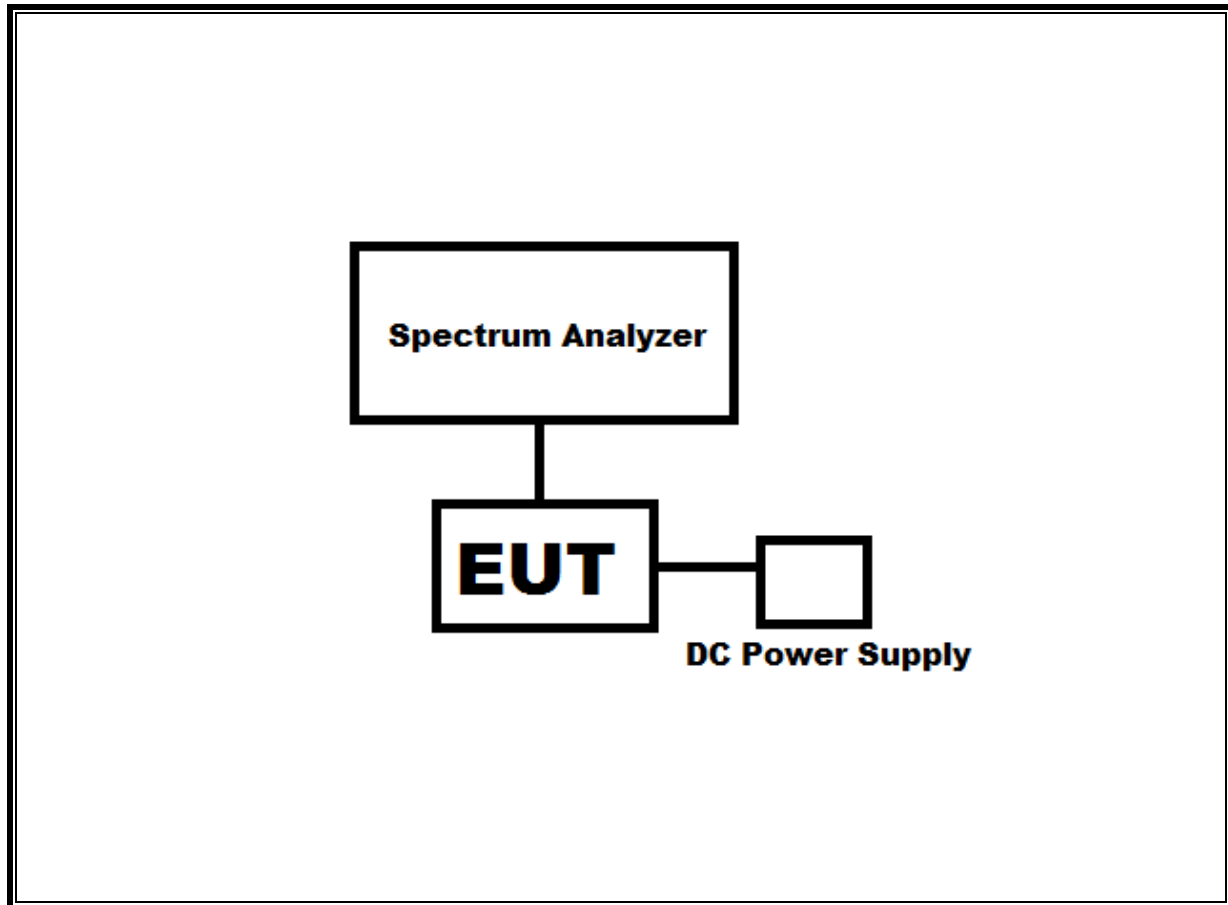

*Note – The DC power supply is used only during testing. During normal operation the EUT is powered by a supplied battery pack

SETUP DIAGRAM FOR RADIATED TESTS

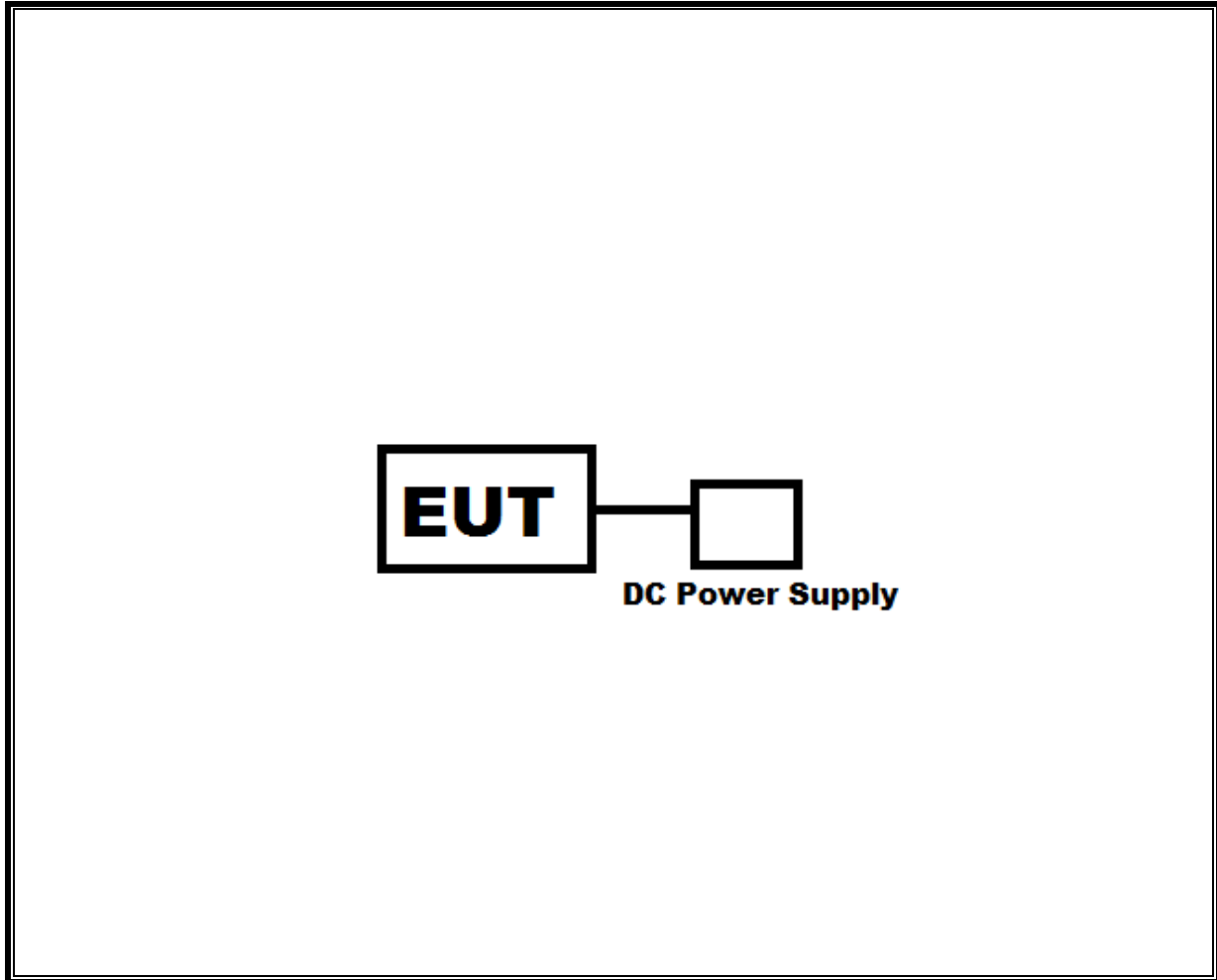

*Note – The DC power supply is used only during testing. During normal operation the EUT is powered by a supplied battery pack

6. MEASUREMENT METHOD

On Time and Duty Cycle: ANSI C63.10-2013 Section 11.6

Occupied BW (20dB): ANSI C63.10-2013 Section 6.9.2

Occupied BW (99%): ANSI C63.10-2013 Section 6.9.3

Conducted Band-Edge: ANSI C63.10-2013 Section 6.10.4

Radiated Spurious Emissions 30-1000MHz: ANSI C63.10-2013 Section 6.3 and 6.5

Radiated Spurious Emissions above 1GHz: ANSI C63.10-2013 Section 6.3 and 6.6

Radiated Band-edge: ANSI C63.10-2013 Section 6.10.5

7. TEST AND MEASUREMENT EQUIPMENT

The following test and measurement equipment was utilized for the tests documented in this:

Test Equipment List					
Description	Manufacturer	Model	ID No.	Cal Date	Cal Due
Spectrum Analyzer	Agilent	N9030A	T1210	07/17/17	07/17/18
Spectrum Analyzer	Agilent	N9030A	T1466	04/16/18	04/16/19
Antenna, Biconolog, 30MHz-1 GHz	Sunol Sciences	JB1	T130	10/16/17	10/16/18
Antenna, Horn, 1-18GHz	ETS Lindgren	3117	T862	06/09/17	06/09/18
RF Preamplifier, 10kHz - 1GHz	HP	8447D	T15	08/14/17	08/14/18
RF Preamplifier, 1 - 18GHz	Miteq	AFS42-00101800-25-S-42	T1165	11/25/17	11/25/18
RF Preamplifier, 1-8GHz	Miteq	AMF-4D-01000800-30-29P	T1573	11/25/17	11/25/18
High Pass Filter 3GHz	Micro-Tronics	HPM17543	T486	11/25/17	11/25/18
Antenna, Active Loop 9kHz – 30MHz	Com-Power	AL-130R	T1866	10/10/17	10/10/18
Antenna, Horn, 18-26GHz	ARA	MWH-1826G	T89	01/18/18	01/18/19
Spectrum Analyzer	Keysight	N9030A	T1113	12/21/17	12/21/18
RF Preamplifier, 1-26GHz	Agilent	8449B	T404	07/23/17	07/23/18
RF Power Meter	Agilent	N1911A	T229	08/14/17	08/14/18
RF Power Sensor	Agilent	N1921A	T1225	04/10/18	04/10/19

Test Software List			
Description	Manufacturer	Model	Version
Radiated Software	UL	UL EMC	Ver 9.5, Dec 01, 2016
Antenna Port Software	UL	UL RF	Ver 7.8, Jan 10, 2018

8. ANTENNA PORT TEST RESULTS

8.1. ON TIME AND DUTY CYCLE

LIMITS

None; for reporting purposes only.

PROCEDURE

KDB 789033 Zero-Span Spectrum Analyzer Method.

ON TIME AND DUTY CYCLE RESULTS

Mode	ON Time B (msec)	Period (msec)	Duty Cycle x (linear)	Duty Cycle (%)	Duty Cycle Correction Factor (dB)	1/B Minimum VBW (kHz)
ANT+	100.0	100.0	1.000	100.00%	0.00	0.010

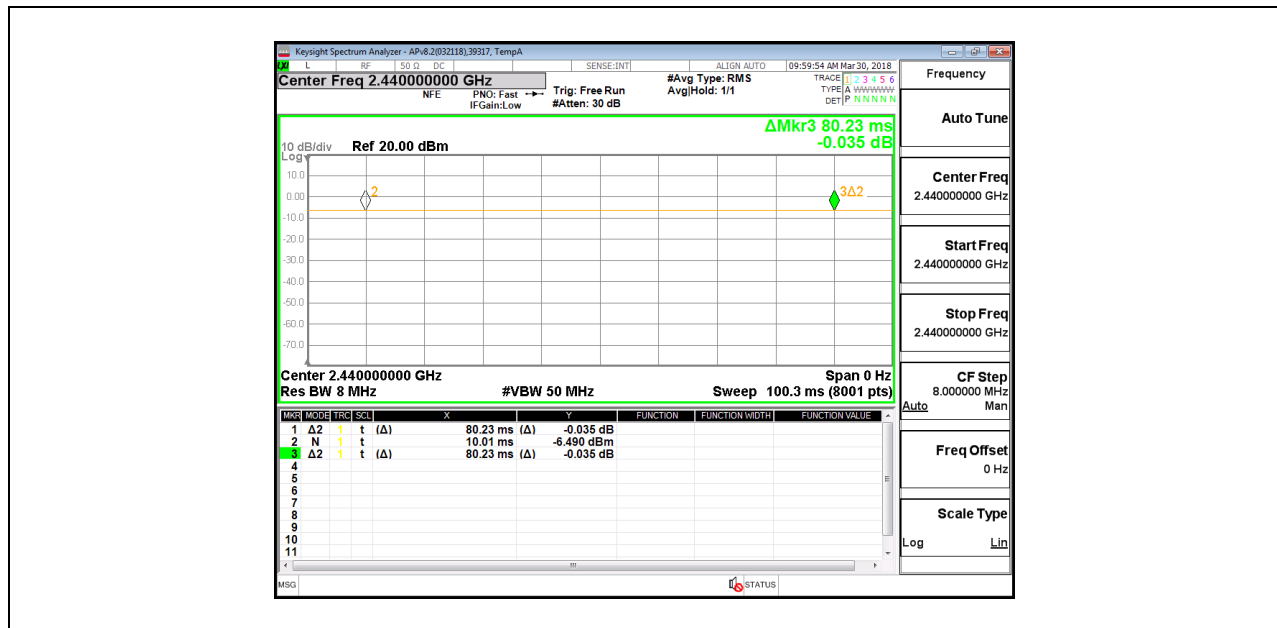

8.2. 99% BANDWIDTH

LIMITS

None; for reporting purposes only.

RESULTS

Channel	Frequency (MHz)	99% Bandwidth (KHz)
Low	2405	895.13
Mid	2440	894.3
High	2475	917.64

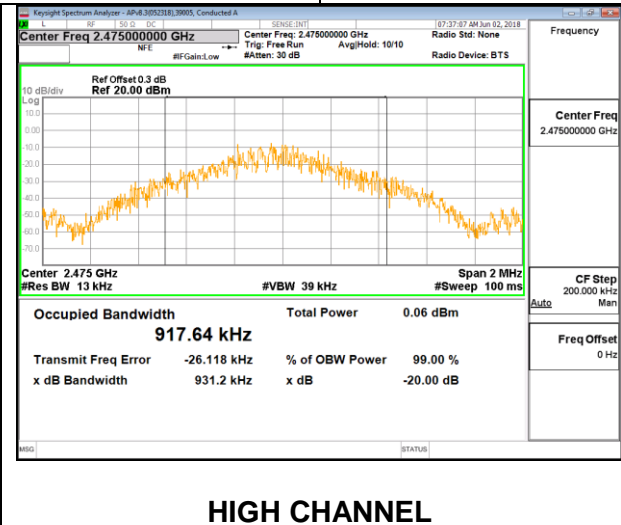
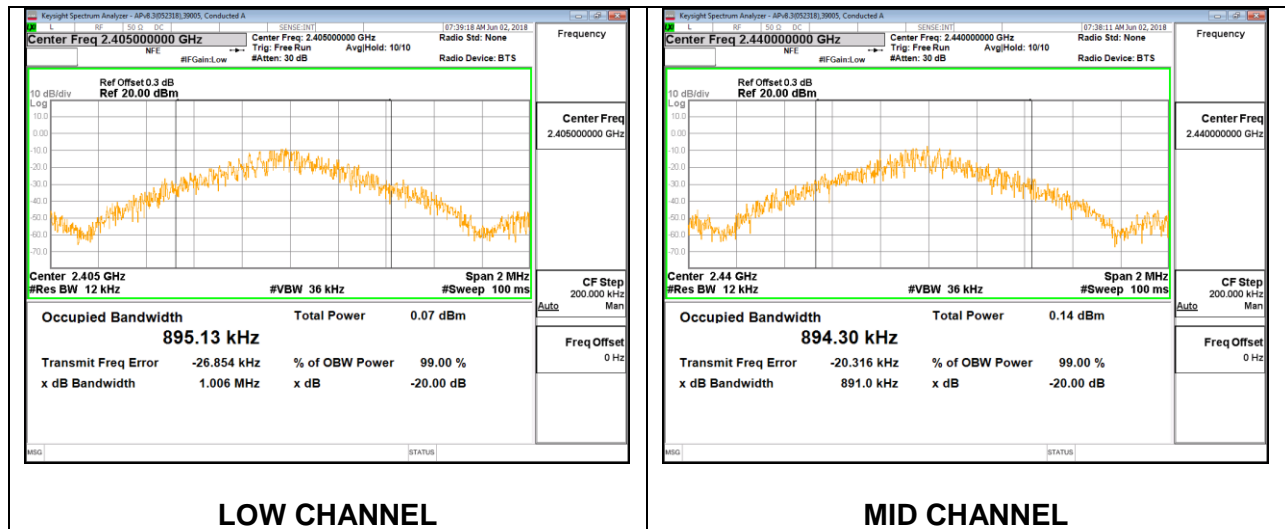

8.3. 20dB BANDWIDTH

LIMITS

None; for reporting purposes only.

TEST PROCEDURE

The transmitter output is connected to a spectrum analyzer. The RBW is set to $\geq 1\%$ of the 20 dB bandwidth. The VBW is set to \geq RBW. The sweep time is coupled

RESULTS

Test table results for FCC Rule Part15.215(c): Compliant.

Channel	Frequency (MHz)	20dB Bandwidth (MHz)	Frequency Edge (MHz)	Limit (MHz)	Margin (MHz)
Low	2405	1.0060	2404.4970	2400	-4.50
Mid	2440	0.8910	N/A	N/A	N/A
High	2475	0.9312	2475.4656	2483.5	-8.03

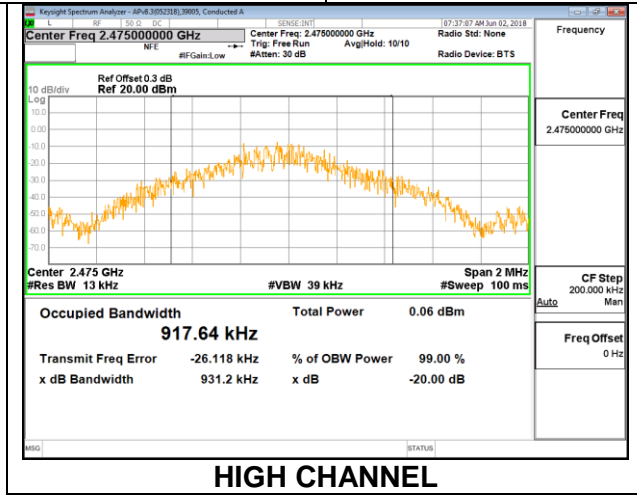
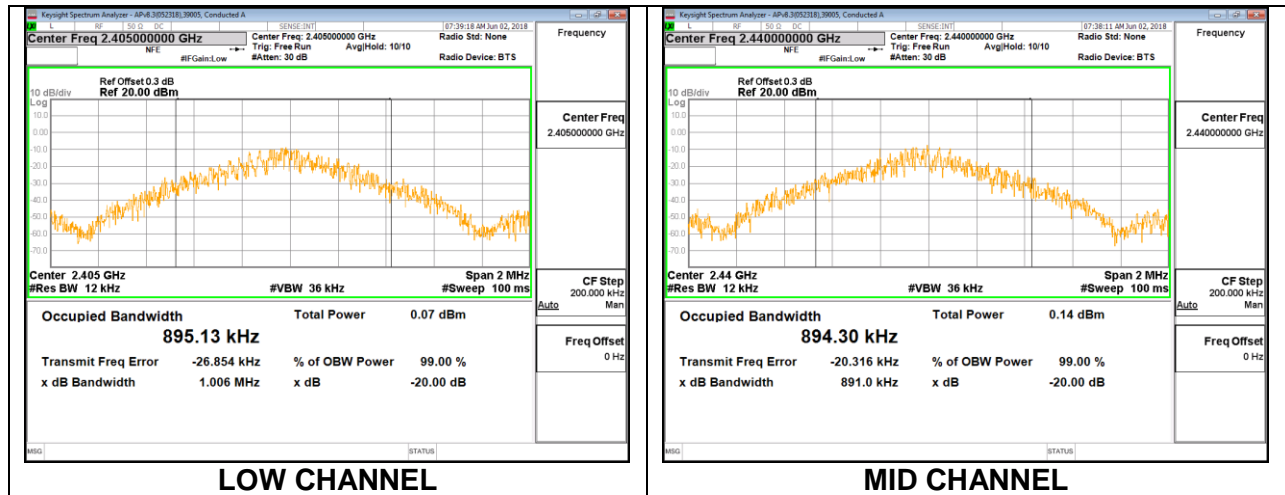

9. RADIATED TEST RESULTS

LIMITS

FCC 15.249
 FCC §15.205 and §15.209

RSS-GEN, Section 8.9 and 8.10.

Operation within the bands 902–928 MHz, 2400–2483.5 MHz, 5725–5875 MHz, and 24.0–24.25 GHz.

(a) Except as provided in paragraph (b) of this section, the field strength of emissions from intentional radiators operated within these frequency bands shall comply with the following:

Fundamental frequency	Field strength of fundamental (millivolts/meter)	Field strength of harmonics (microvolts/meter)
902–928 MHz	50	500
2400–2483.5 MHz	50	500
5725–5875 MHz	50	500
24.0–24.25 GHz	250	2500

(d) Emissions radiated outside of the specified frequency bands, except for harmonics, shall be attenuated by at least 50 dB below the level of the fundamental or to the general radiated emission limits in § 15.209, whichever is the lesser attenuation.

(e) As shown in Sec. 15.35(b), for frequencies above 1000 MHz, the field strength limits in paragraphs (a) and (b) of this section are based on average limits. However, the peak field strength of any emission shall not exceed the maximum permitted average limits specified above by more than 20 dB under any condition of modulation.

Frequency (MHz)	Field strength (microvolts/meter)	Measurement distance (meters)
0.009–0.490	2400/F(kHz)	300
0.490–1.705	24000/F(kHz)	30
1.705–30.0	30	30
30–88	100 **	3
88–216	150 **	3
216–960	200 **	3
Above 960	500	3

** Except as provided in paragraph (g), fundamental emissions from intentional radiators operating under this section shall not be located in the frequency bands 54–72 MHz, 76–88 MHz, 174–216 MHz or 470–806 MHz. However, operation within these frequency bands is permitted under other sections of this part, e.g., §§15.231 and 15.241.

TEST PROCEDURE

The EUT is placed on a non-conducting table 80 cm above the ground plane for measurement below 1GHz; 1.5 m above the ground plane for measurement above 1GHz. The antenna to EUT distance is 3 meters. The EUT is configured in accordance with ANSI C63.10. The EUT is set to transmit in a continuous mode.

For measurements below 1 GHz the resolution bandwidth is set to 100 kHz for peak detection measurements or 120 kHz for quasi-peak detection measurements. Peak detection is used unless otherwise noted as quasi-peak.

For pre-scans above 1 GHz the resolution bandwidth is set to 1 MHz; the video bandwidth is set to 30 KHz for peak measurements.

For final measurements above 1 GHz the resolution bandwidth is set to 1 MHz; the video bandwidth is set to 3 MHz for peak measurements and as applicable for average measurements.

The spectrum from 1 GHz to 18 GHz is investigated with the transmitter set to the lowest, middle, and highest channels in each applicable band. Below 1GHz and above 18GHz emissions, the channel with the highest output power was tested.

The frequency range of interest is monitored at a fixed antenna height and EUT azimuth. The EUT is rotated through 360 degrees to maximize emissions received. The antenna is scanned from 1 to 4 meters above the ground plane to further maximize the emission. Measurements are made with the antenna polarized in both the vertical and the horizontal positions.

9.1. TRANSMITTER ABOVE 1 GHz

BANDEDGE (LOW CHANNEL)

HORIZONTAL RESULT



Trace Markers

Marker	Frequency (GHz)	Meter Reading (dBuV)	Det	AF T862 (dB/m)	Amp/Ch/Fltr/Pad (dB)	DC Corr (dB)	Corrected Reading (dBuV/m)	Average Limit (dBuV/m)	Margin (dB)	Peak Limit (dBuV/m)	PK Margin (dB)	Azimuth (Degs)	Height (cm)	Polarity
1	* 2.39	36.95	Pk	31.8	-23.5	0	45.25	-	-	74	-28.75	346	345	H
2	* 2.388	39.28	Pk	31.8	-23.5	0	47.58	-	-	74	-26.42	346	345	H
3	* 2.39	26.41	RMS	31.8	-23.5	0	34.71	54	-19.29	-	-	346	345	H
4	* 2.381	28	RMS	31.7	-23.5	0	36.2	54	-17.8	-	-	346	345	H

* - indicates frequency in CFR47 Pt 15 / IC RSS-Restricted Band

Pk - Peak detector

RMS - RMS detection

VERTICAL RESULT

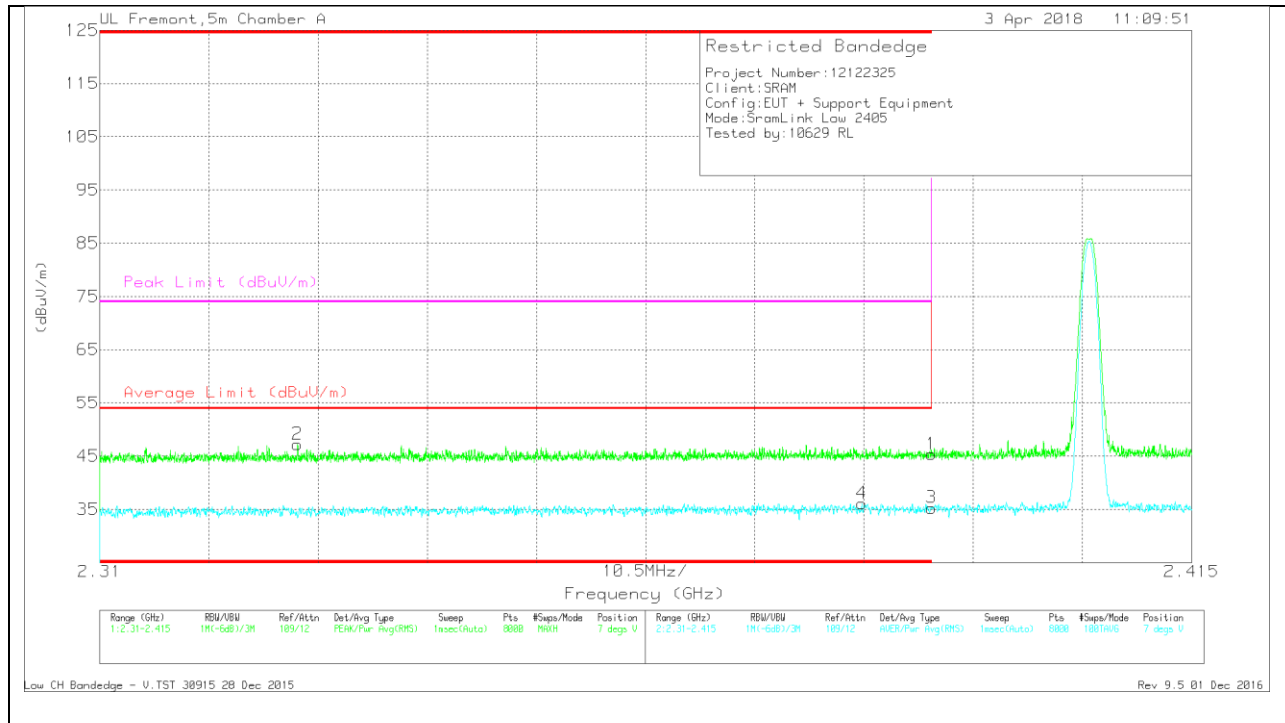

Trace Markers

Marker	Frequency (GHz)	Meter Reading (dBuV)	Det	AF T862 (dB/m)	Amp/Cb/Filtr/Pad (dB)	Corrected Reading (dBuV/m)	Average Limit (dBuV/m)	Margin (dB)	Peak Limit (dBuV/m)	PK Margin (dB)	Azimuth (Degs)	Height (cm)	Polarity
2	* 2.329	39.23	Pk	31.6	-23.6	47.23	-	-	74	-26.77	7	269	V
4	* 2.383	27.91	RMS	31.7	-23.5	36.11	54	-17.89	-	-	7	269	V
1	* 2.39	37.07	Pk	31.8	-23.5	45.37	-	-	74	-28.63	7	269	V
3	* 2.39	26.99	RMS	31.8	-23.5	35.29	54	-18.71	-	-	7	269	V

* - indicates frequency in CFR47 Pt 15 / IC RSS-Restricted Band

Pk - Peak detector

RMS - RMS detection

BANDEDGE (HIGH CHANNEL)

HORIZONTAL RESULT

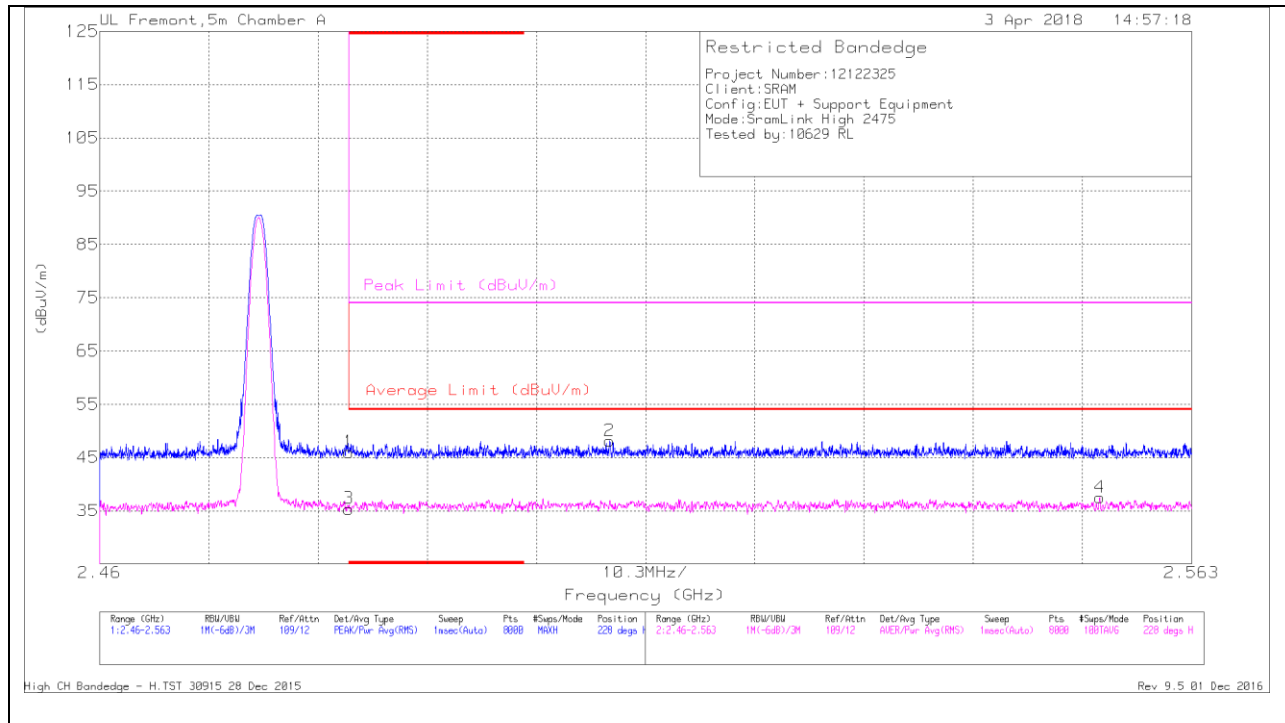

Trace Markers

Marker	Frequency (GHz)	Meter Reading (dBuV)	Det	AF T862 (dB/m)	Amp/Cbl/Ftr/Pad (dB)	DC Corr (dB)	Corrected Reading (dBuV/m)	Average Limit (dBuV/m)	Margin (dB)	Peak Limit (dBuV/m)	PK Margin (dB)	Azimuth (Degs)	Height (cm)	Polarity
1	* 2.484	37.1	Pk	32.3	-23.4	0	46	-	-	74	-28	228	146	H
3	* 2.484	26.46	RMS	32.3	-23.4	0	35.36	54	-18.64	-	-	228	146	H
2	2.508	39.12	Pk	32.4	-23.4	0	48.12	-	-	74	-25.88	228	146	H
4	2.554	28.49	RMS	32.3	-23.3	0	37.49	54	-16.51	-	-	228	146	H

* - indicates frequency in CFR47 Pt 15 / IC RSS-Restricted Band

Pk - Peak detector

RMS - RMS detection

VERTICAL RESULT

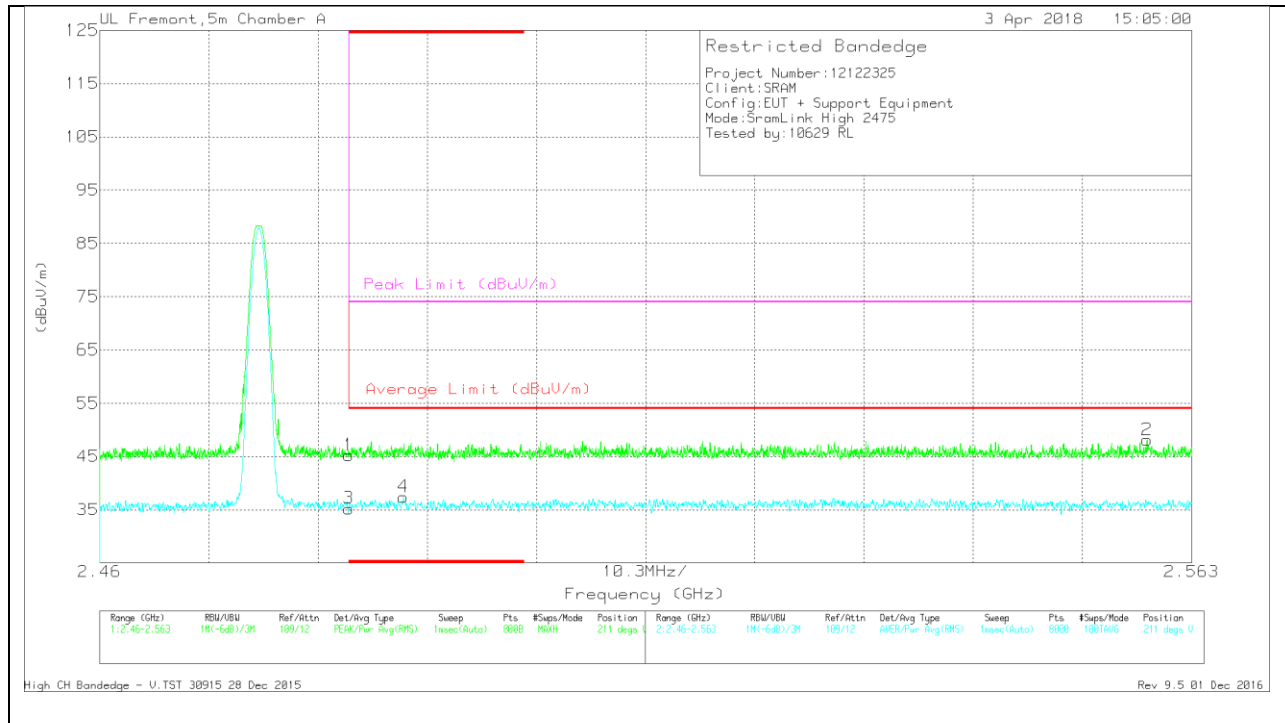

Trace Markers

Marker	Frequency (GHz)	Meter Reading (dBuV)	Det	AF T862 (dB/m)	Amp/Cb/Ftr/Pad (dB)	DC Corr (dB)	Corrected Reading (dBuV/m)	Average Limit (dBuV/m)	Margin (dB)	Peak Limit (dBuV/m)	PK Margin (dB)	Azimuth (Degs)	Height (cm)	Polarity
1	* 2.484	36.31	Pk	32.3	-23.4	0	45.21	-	-	74	-28.79	211	397	V
3	* 2.484	26.34	RMS	32.3	-23.4	0	35.24	54	-18.76	-	-	211	397	V
4	* 2.489	28.4	RMS	32.4	-23.4	0	37.4	54	-16.6	-	-	211	397	V
2	2.559	39.04	Pk	32.4	-23.3	0	48.14	-	-	74	-25.86	211	397	V

* - indicates frequency in CFR47 Pt 15 / IC RSS-Restricted Band

Pk - Peak detector

RMS - RMS detection

HARMONICS AND SPURIOUS EMISSIONS

LOW CHANNEL RESULTS

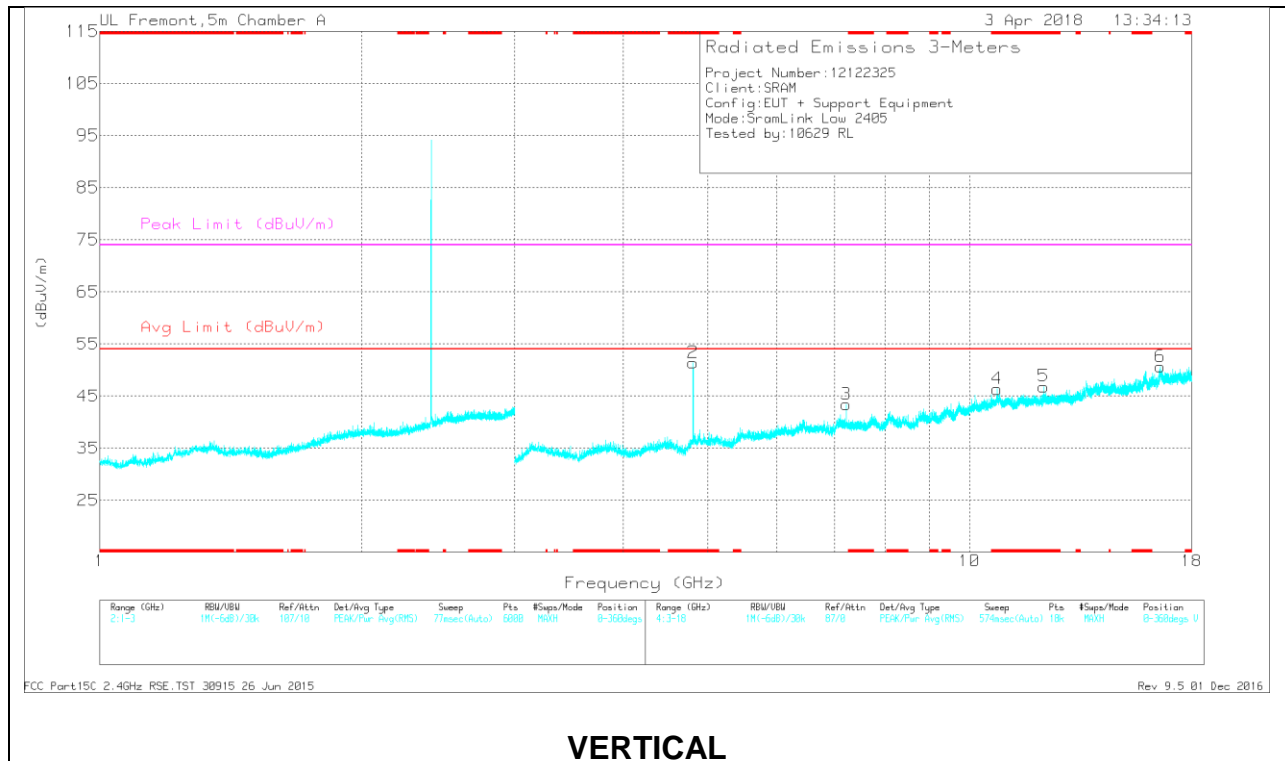
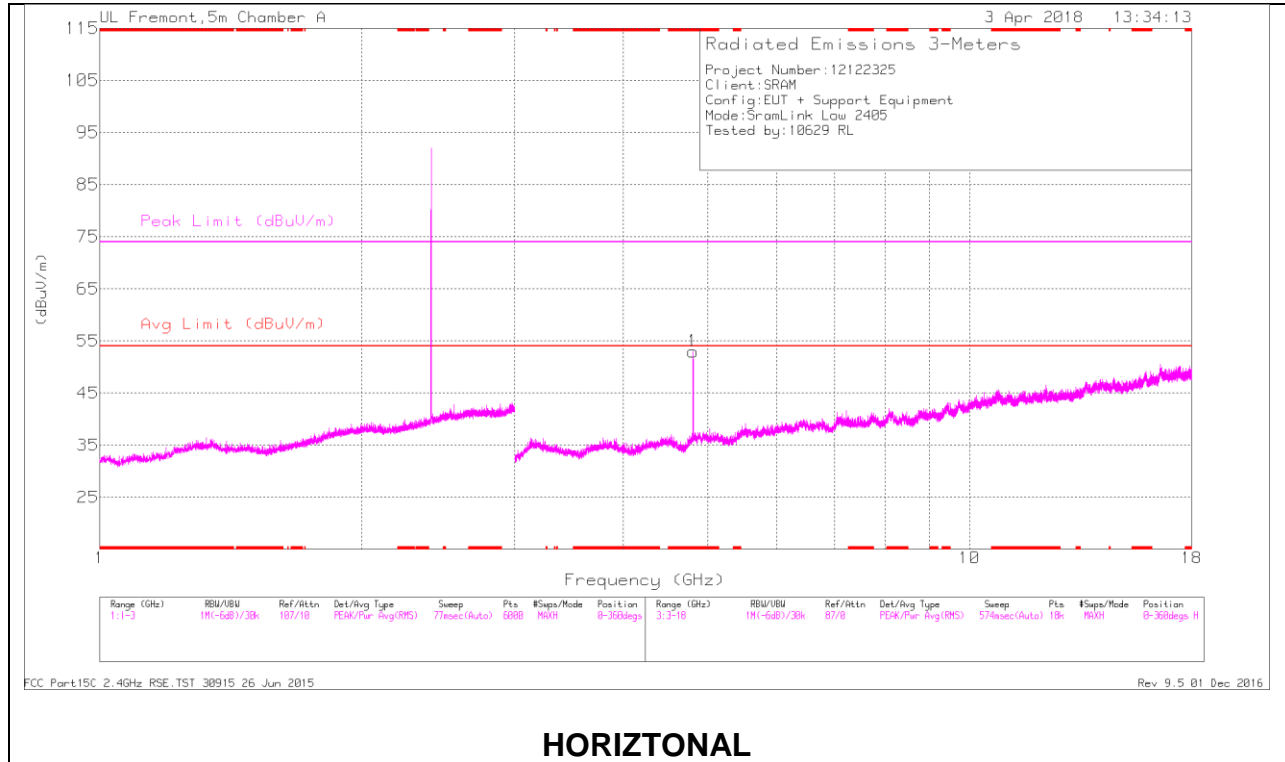

Radiated Emissions

Marker	Frequency (GHz)	Meter Reading (dBuV)	Det	AF T862 (dB/m)	Amp/Cb/Filtr/Par d (dB)	DC Corr (dB)	Corrected Reading (dBuV/m)	Avg Limit (dBuV/m)	Margin (dB)	Peak Limit (dBuV/m)	PK Margin (dB)	Azimuth (Degs)	Height (cm)	Polarity
1	* 4.81	46.93	PK2	34.2	-26.7	0	54.43	-	-	74	-19.57	40	329	H
	* 4.81	43.4	MAv1	34.2	-26.7	0	50.9	54	-3.1	-	-	40	329	H
2	* 4.81	46.09	PK2	34.2	-26.7	0	53.59	-	-	74	-20.41	2	240	V
	* 4.81	42.35	MAv1	34.2	-26.7	0	49.85	54	-4.15	-	-	2	240	V
4	* 10.751	32.06	PK2	37.8	-18.6	0	51.26	-	-	74	-22.74	245	184	V
	* 10.746	20.67	MAv1	37.8	-18.8	0	39.67	54	-14.33	-	-	245	184	V
5	* 12.162	32.08	PK2	39	-19.3	0	51.78	-	-	74	-22.22	351	224	V
	* 12.16	20.21	MAv1	39	-19.3	0	39.91	54	-14.09	-	-	351	224	V
3	7.215	31.08	Pk	35.7	-23.4	0	43.38	-	-	-	-	0-360	201	V
6	16.567	26.12	Pk	41.3	-16.8	0	50.62	-	-	-	-	0-360	101	V

* - indicates frequency in CFR47 Pt 15 / IC RSS-Restricted Band

PK2 - KDB558074 Method: Maximum Peak

MAv1 - KDB558074 Option 1 Maximum RMS Average

MID CHANNEL RESULTS

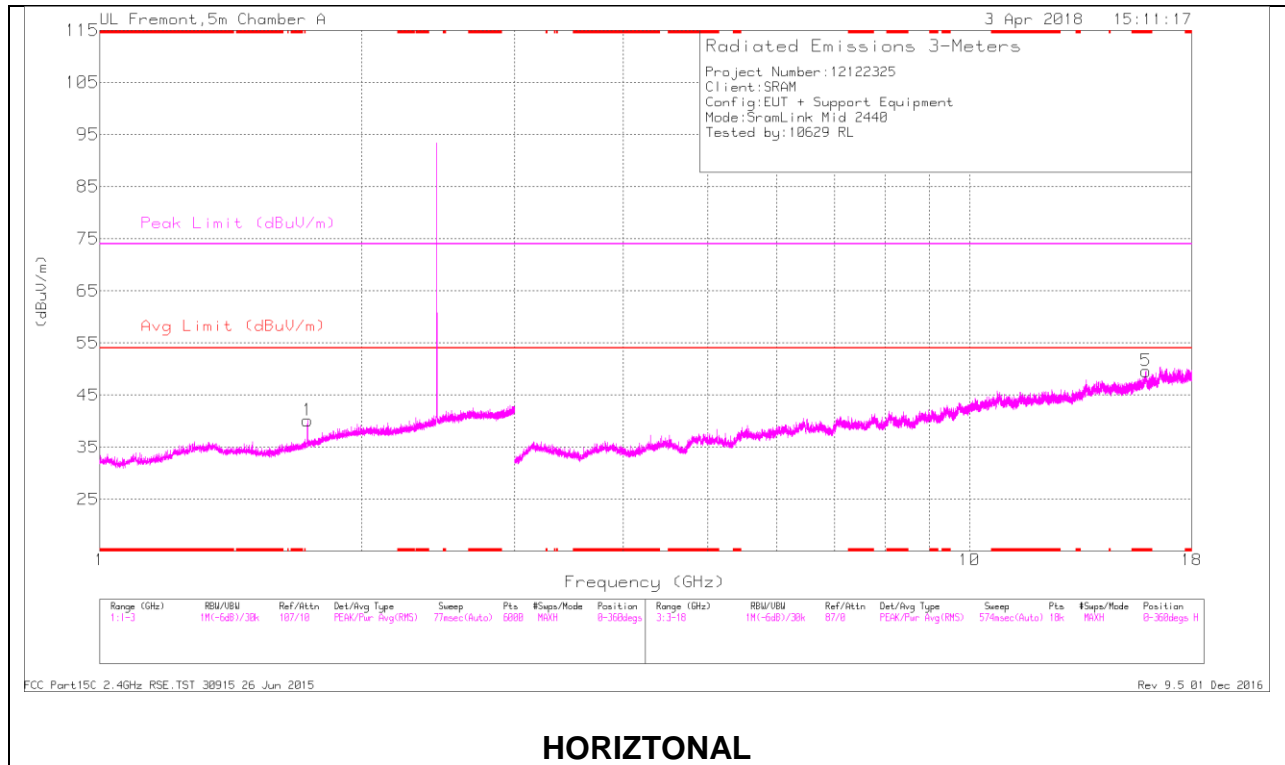

HORIZONTAL

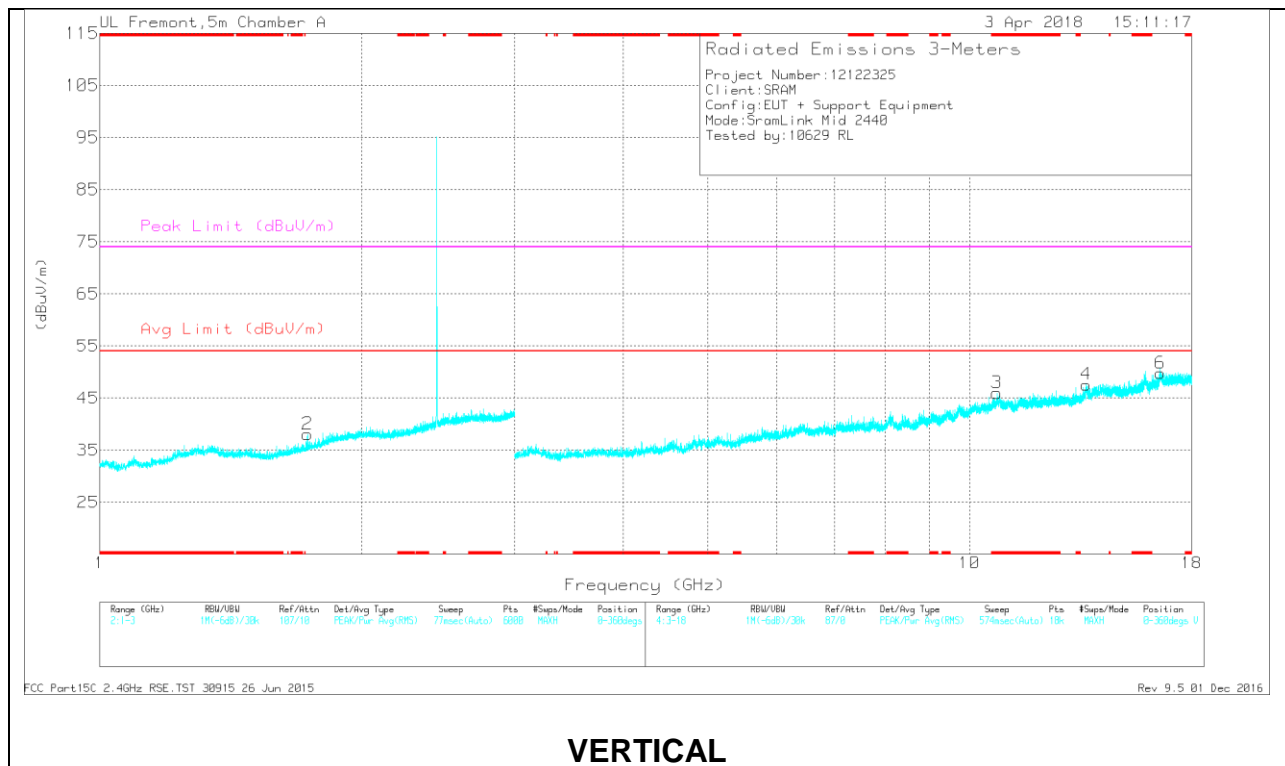

VERTICAL

Radiated Emissions

Marker	Frequency (GHz)	Meter Reading (dBuV)	Det	AF T862 (dB/m)	Amp/Cb/Filtr/Pad (dB)	DC Corr (dB)	Corrected Reading (dBuV/m)	Avg Limit (dBuV/m)	Margin (dB)	Peak Limit (dBuV/m)	PK Margin (dB)	Azimuth (Degs)	Height (cm)	Polarity
5	* 15.955	31.87	PK2	40.4	-16.9	0	55.37	-	-	74	-18.63	238	277	H
	* 15.958	20.92	MAv1	40.4	-17.1	0	44.22	54	-9.78	-	-	238	277	H
3	* 10.746	31.84	PK2	37.8	-18.8	0	50.84	-	-	74	-23.16	199	346	V
	* 10.747	21.06	MAv1	37.8	-18.8	0	40.06	54	-13.94	-	-	199	346	V
1	1.734	34.22	Pk	29.5	-23.6	0	40.12	-	-	-	-	0-360	101	H
2	1.734	32.17	Pk	29.5	-23.6	0	38.07	-	-	-	-	0-360	101	V
4	13.618	26.99	Pk	39.2	-18.6	0	47.59	-	-	-	-	0-360	200	V
6	16.562	25.25	Pk	41.3	-16.8	0	49.75	-	-	-	-	0-360	200	V

* - indicates frequency in CFR47 Pt 15 / IC RSS-Restricted Band

PK2 - KDB558074 Method: Maximum Peak

MAv1 - KDB558074 Option 1 Maximum RMS Average

HIGH CHANNEL RESULTS

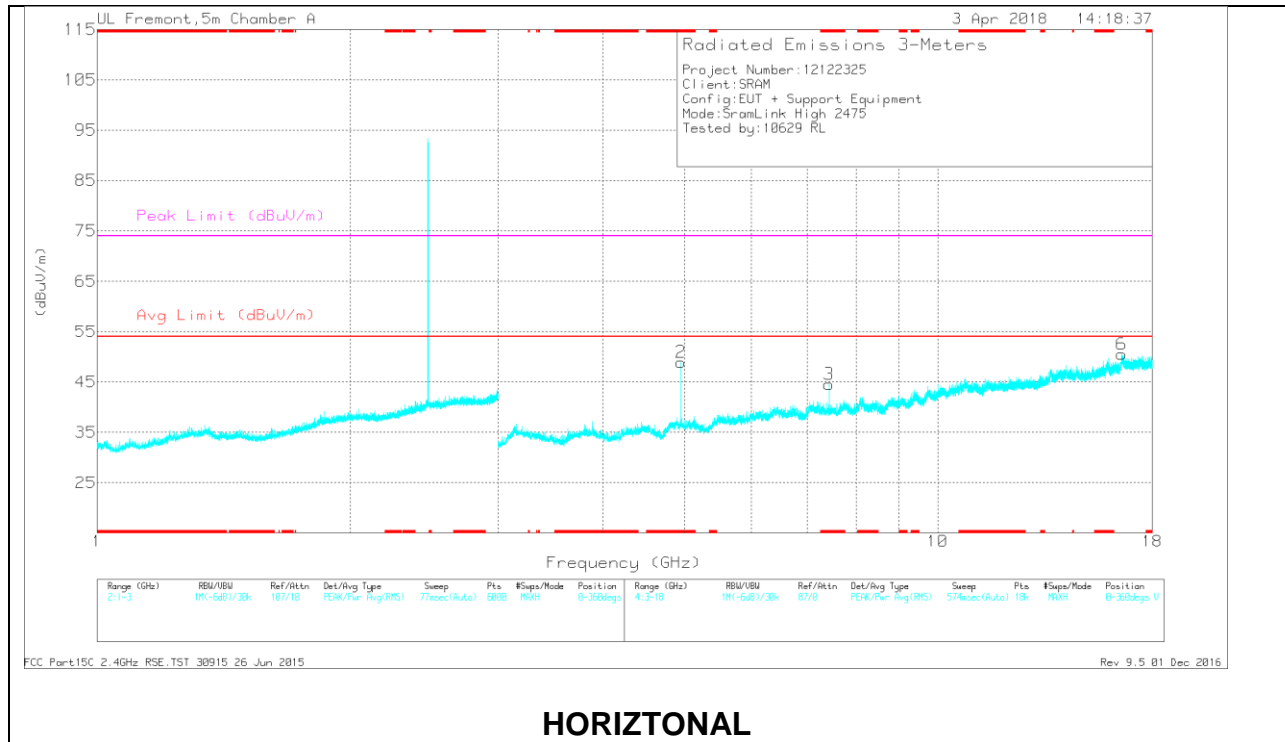

HORIZONTAL

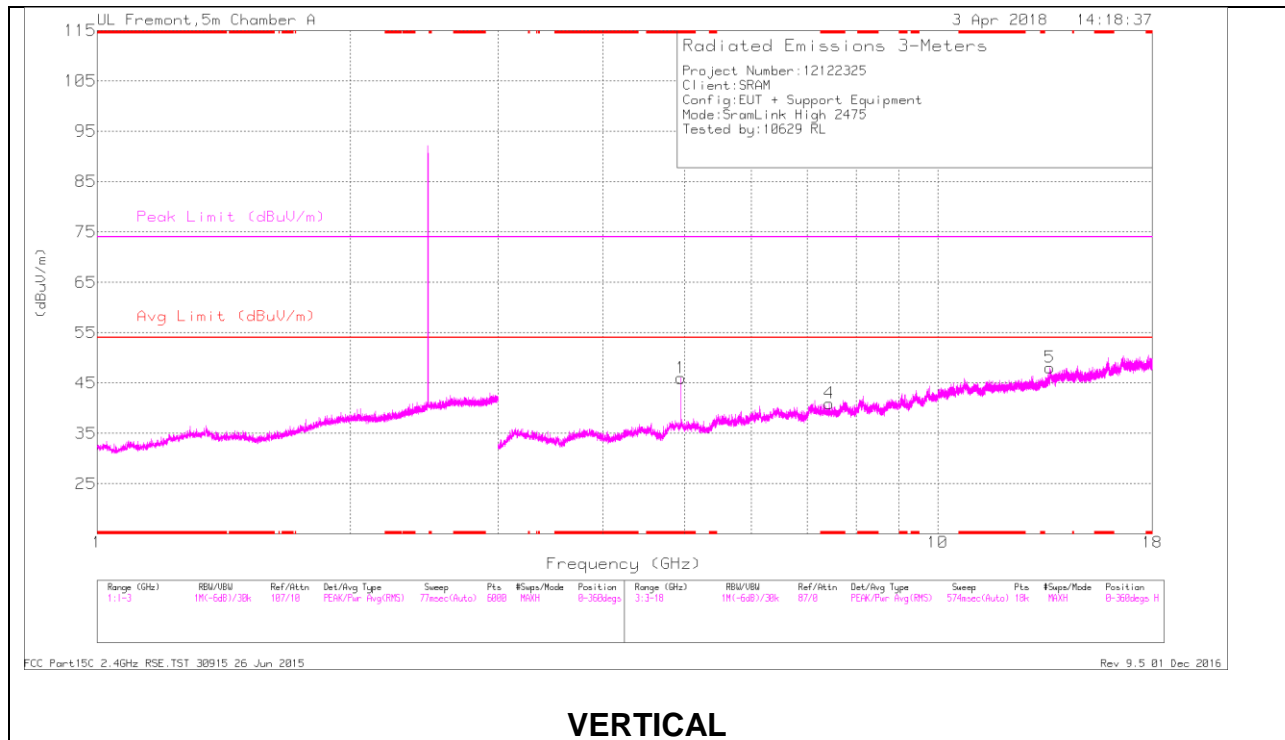

VERTICAL

Radiated Emissions

Marker	Frequency (GHz)	Meter Reading (dBuV)	Det	AF T862 (dB/m)	Amp/Cb/Ftr/ Pad (dB)	DC Corr (dB)	Corrected Reading (dBuV/m)	Avg Limit (dBuV/m)	Margin (dB)	Peak Limit (dBuV/m)	PK Margin (dB)	Azimuth (Degs)	Height (cm)	Polarity
1	* 4.95	45.15	PK2	34.2	-27.3	0	52.05	-	-	74	-21.95	41	312	H
	* 4.95	40.41	MAv1	34.2	-27.3	0	47.31	54	-6.69	-	-	41	312	H
4	* 7.426	34.79	PK2	35.6	-22.3	0	48.09	-	-	74	-25.91	22	201	H
	* 7.425	25.42	MAv1	35.6	-22.4	0	38.62	54	-15.38	-	-	22	201	H
2	* 4.95	46.52	PK2	34.2	-27.3	0	53.42	-	-	74	-20.58	24	217	V
	* 4.95	42.19	MAv1	34.2	-27.3	0	49.09	54	-4.91	-	-	24	217	V
3	* 7.425	36.75	PK2	35.6	-22.4	0	49.95	-	-	74	-24.05	147	201	V
	* 7.425	28.89	MAv1	35.6	-22.4	0	42.09	54	-11.91	-	-	147	201	V
5	13.603	27.49	Pk	39.2	-18.6	0	48.09	-	-	-	-	0-360	101	H
6	16.552	26.03	Pk	41.3	-16.8	0	50.53	-	-	-	-	0-360	101	V

* - indicates frequency in CFR47 Pt 15 / IC RSS-Restricted Band

PK2 - KDB558074 Method: Maximum Peak

MAv1 - KDB558074 Option 1 Maximum RMS Average

9.2. FUNDAMENTAL FREQUENCY RADIATED EMISSION

Frequency (GHz)	Meter Reading (dBuV)	Det	AF T862 (dB/m)	Amp/Cb/Fitr/Pa d (dB)	Corrected Reading (dBuV/m)	Avg Limit (dBuV/m)	Margin (dB)	Peak Limit (dBuV/m)	PK Margin (dB)	Azimuth (Degs)	Height (cm)	Polarity
2.405	80.8	PKFH	31.9	-23.4	89.3	-	-	114	-24.7	100	312	H
	80.3	VA1T	31.9	-23.4	88.8	94	-5.2	-	-	100	312	H
	82.32	PKFH	31.9	-23.4	90.82	-	-	114	-23.18	7	246	V
	81.88	VA1T	31.9	-23.4	90.38	94	-3.62	-	-	7	246	V
2.44	82.33	PKFH	32.1	-23.3	91.13	-	-	114	-22.87	100	250	H
	81.82	VA1T	32.1	-23.3	90.62	94	-3.38	-	-	100	250	H
	83.57	PKFH	32.1	-23.3	92.37	-	-	114	-21.63	355	258	V
	83.05	VA1T	32.1	-23.3	91.85	94	-2.45	-	-	355	258	V
2.475	80.36	PKFH	32.3	-23.3	89.36	-	-	114	-24.64	297	261	H
	79.89	VA1T	32.3	-23.3	88.89	94	-5.11	-	-	297	261	H
	83.54	PKFH	32.3	-23.3	92.54	-	-	114	-21.46	312	311	V
	83.01	VA1T	32.3	-23.3	92.01	94	-1.99	-	-	312	311	V

PKFH - FHSS: RB=100k/1MHz VB=3 x RB, Peak

VA1T - FHSS: Linear Voltage Average VB=1/Ton where: Ton is transmit duration

9.3. Worst Case Below 30MHz

SPURIOUS EMISSIONS BELOW 30 MHz (WORST-CASE CONFIGURATION)

FACE ON AND FACE OFF PLOTS

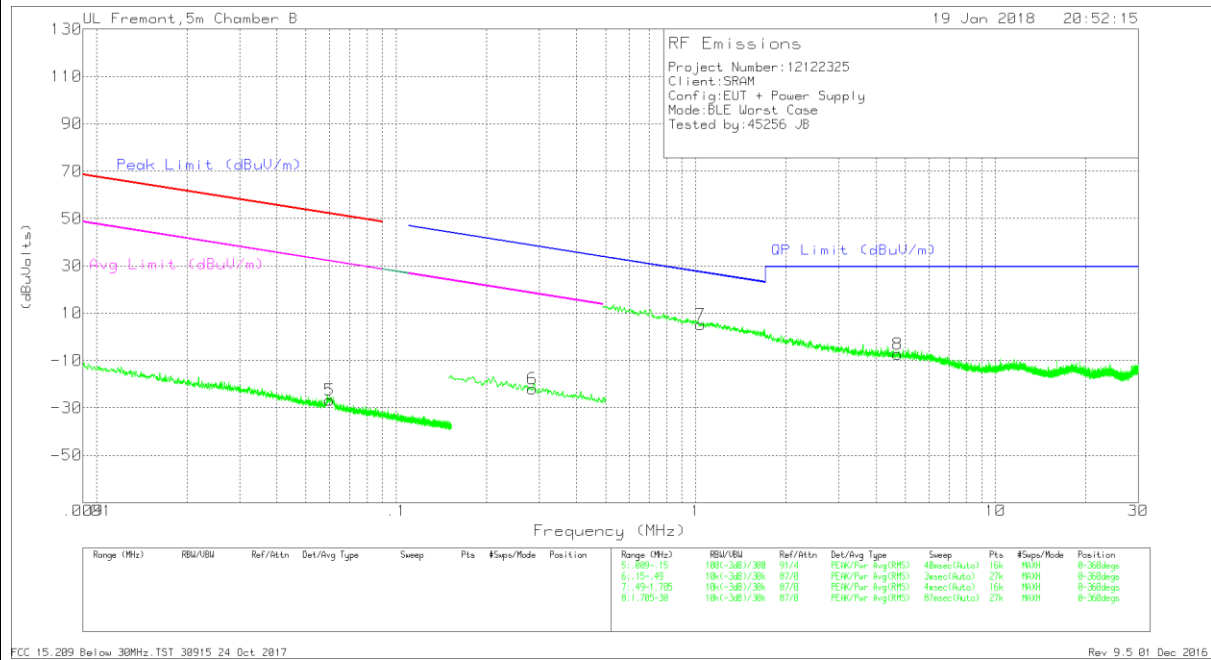

NOTE: KDB 414788 OATS and Chamber Correlation Justification

- Based on FCC 15.31 (f) (2): measurements may be performed at a distance closer than that specified in the regulations; however, an attempt should be made to avoid making measurements in the near field.
- OATs and chamber correlation testing had been performed and chamber measured test result is the worst case test result.

Below 30MHz DATA

Marker	Frequency (MHz)	Meter Reading (dBuV)	Det	Loop Antenna (dB/m)	Cbl (dB)	Dist Corr 300m (dB)	Corrected Reading (dBuVolts)	Peak Limit (dBuV/m)	Margin (dB)	Avg Limit (dBuV/m)	Margin (dB)	Peak Limit (dBuV/m)	Margin (dB)	Avg Limit (dBuV/m)	Margin (dB)	Azimuth (Degs)
1	.05933	37.02	Pk	14.5	1.4	-80	-27.08	52.12	-79.2	32.12	-59.2	-	-	-	-	0-360
5	.05989	37.36	Pk	14.5	1.4	-80	-26.74	52.04	-78.78	32.04	-58.78	-	-	-	-	0-360
6	.28486	42.68	Pk	13.8	1.5	-80	-22.02	-	-	-	-	38.52	-60.54	18.52	-40.54	0-360
2	.29028	43.87	Pk	13.8	1.5	-80	-20.83	-	-	-	-	38.36	-59.19	18.36	-39.19	0-360

Pk - Peak detector

Marker	Frequency (MHz)	Meter Reading (dBuV)	Det	Loop Antenna (dB/m)	Cbl (dB)	Dist Corr (dB) 40Log	Corrected Reading (dBuVolts)	QP Limit (dBuV/m)	Margin (dB)	Azimuth (Degs)
3	1.02804	29.44	Pk	14.3	1.5	-40	5.24	27.38	-22.14	0-360
7	1.03826	29.35	Pk	14.3	1.5	-40	5.15	27.3	-22.15	0-360
4	4.50735	18.03	Pk	14.4	1.5	-40	-6.07	29.5	-35.57	0-360
8	4.72743	16.73	Pk	14.4	1.5	-40	-7.37	29.5	-36.87	0-360

Pk - Peak detector

9.4. Worst Case Below 1 GHz

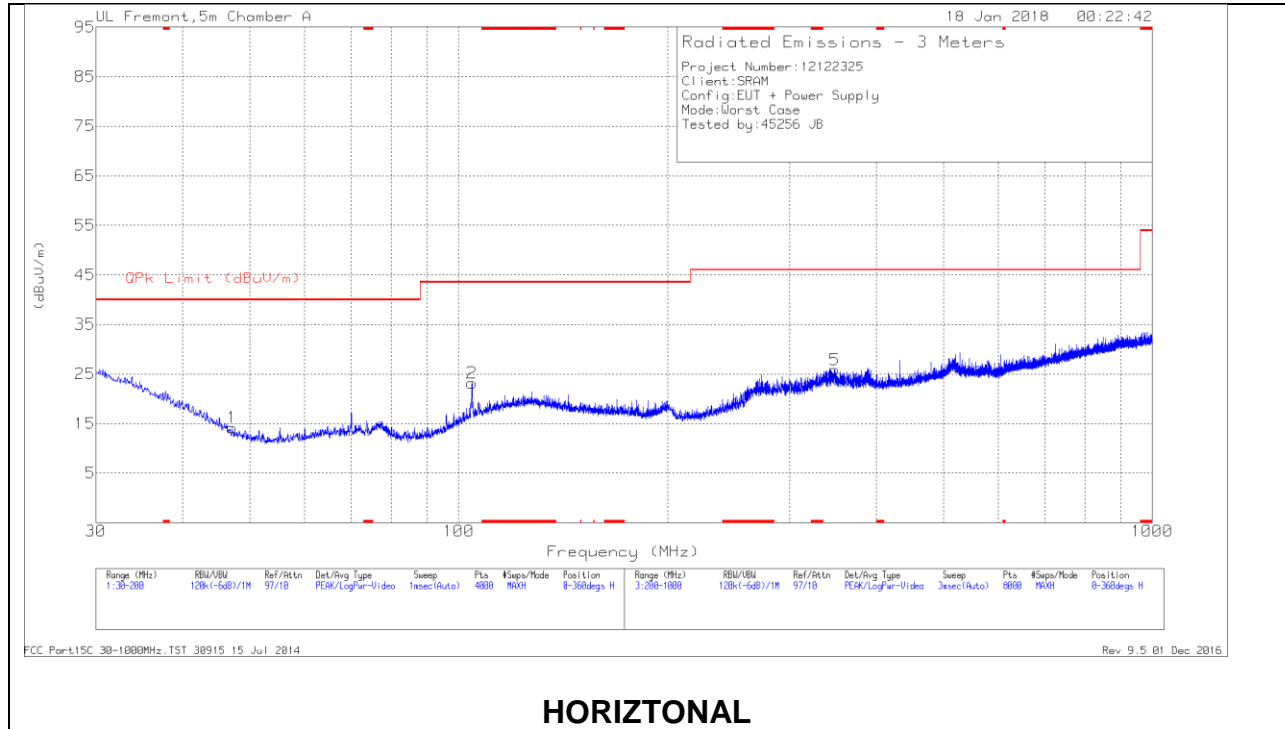

HORIZONTAL

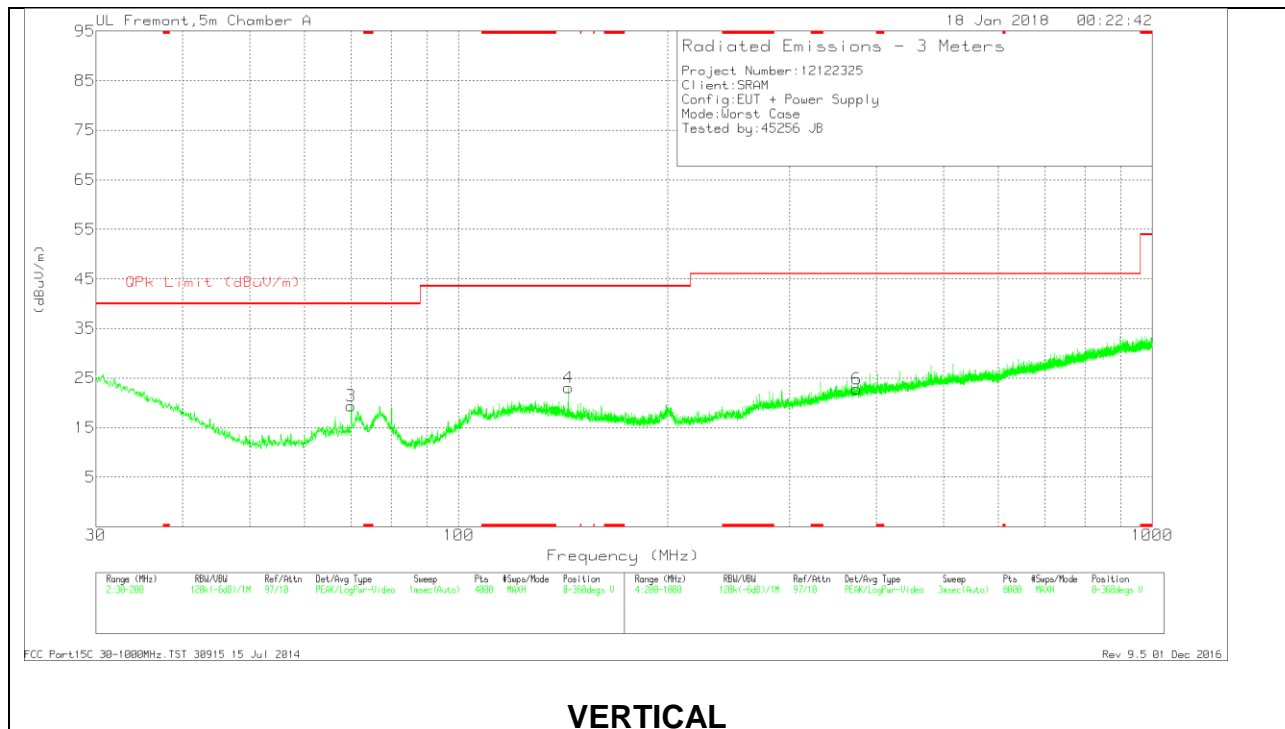

VERTICAL

Below 1GHz Data

Marker	Frequency (MHz)	Meter Reading (dBuV)	Det	AF T130 (dB/m)	Amp/Cbl (dB/m)	Corrected Reading (dBuV/m)	QPk Limit (dBuV/m)	Margin (dB)	Azimuth (Degs)	Height (cm)	Polarity
1	47.1319	28.23	Pk	12.9	-27	14.13	40	-25.87	0-360	200	H
3	70.0029	33.99	Pk	12.1	-26.7	19.39	40	-20.61	0-360	100	V
2	104.5218	34.08	Pk	15.5	-26.4	23.18	43.52	-20.34	0-360	200	H
4	144.0145	32.12	Pk	16.9	-25.9	23.12	43.52	-20.4	0-360	100	V
5	348.3193	32.51	Pk	18.2	-24.8	25.91	46.02	-20.11	0-360	101	H
6	374.7227	28.84	Pk	18.9	-24.9	22.84	46.02	-23.18	0-360	101	V

Pk - Peak detector

9.5. Worst Case 18-26 GHz

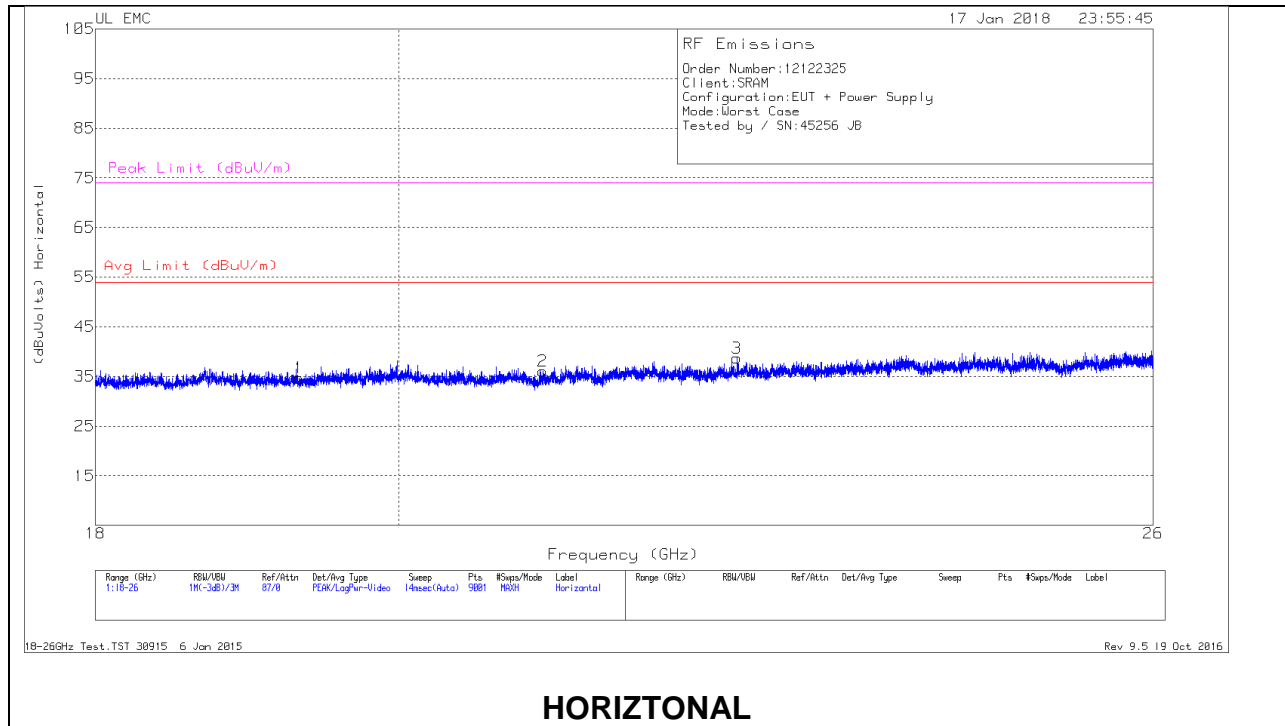

HORIZONTAL

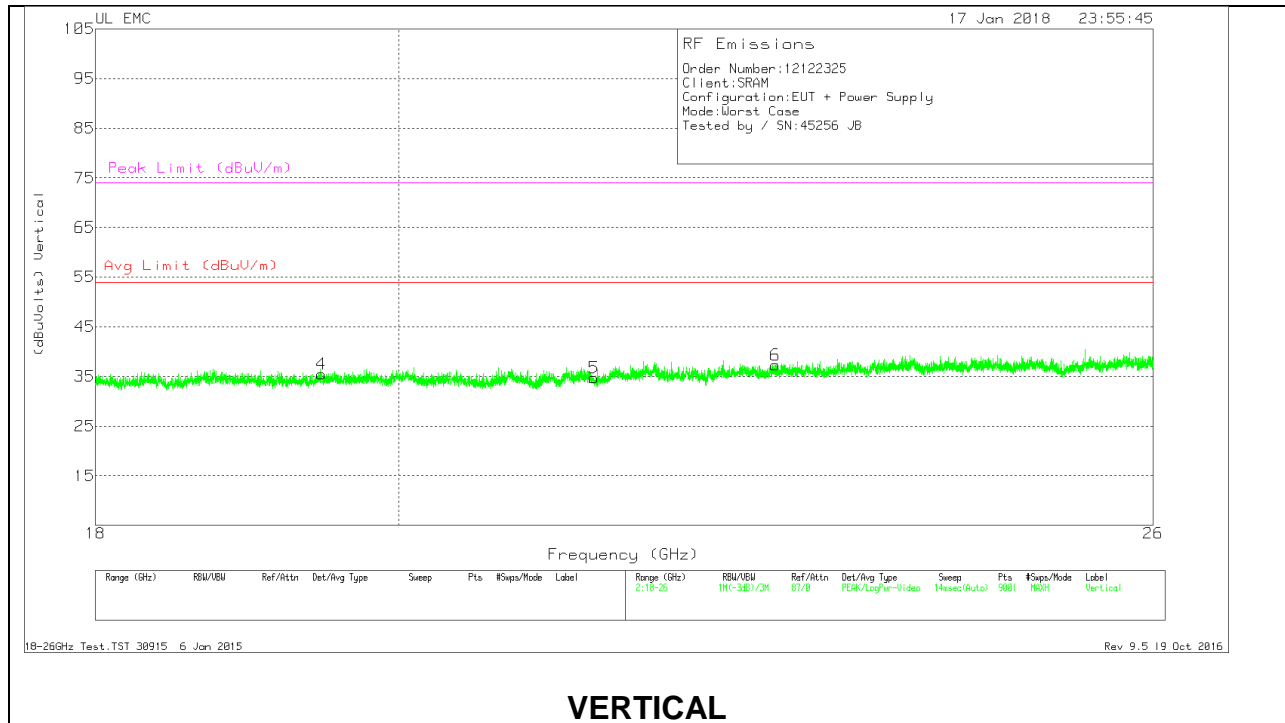

VERTICAL

18 – 26GHz DATA

Marker	Frequency (GHz)	Meter Reading (dBuV)	Det	T89 AF (dB/m)	Amp/Cbl (dB)	Dist Corr (dB)	Corrected Reading (dBuVolts)	Avg Limit (dBuV/m)	Margin (dB)	Peak Limit (dBuV/m)	PK Margin (dB)
1	19.32	36.87	Pk	32.4	-25.1	-9.5	34.67	54	-19.33	74	-39.33
2	21.028	38.35	Pk	32.5	-25.3	-9.5	36.05	54	-17.95	74	-37.95
3	22.496	39.59	Pk	33.4	-24.8	-9.5	38.69	54	-15.31	74	-35.31
4	19.471	37.27	Pk	32.5	-24.8	-9.5	35.47	54	-18.53	74	-38.53
5	21.404	36.71	Pk	33.1	-25.6	-9.5	34.71	54	-19.29	74	-39.29
6	22.8	38.66	Pk	33.2	-25.1	-9.5	37.26	54	-16.74	74	-36.74

Pk - Peak detector