

REVISION RECORD	
REV	
A	RELEASE
B	CHANGE: 76.5 WAS 76.0 (D8), 56.1 (C6) WAS 56.0, ARTWORK, DIE LINE AND SUBSTRATE (NOTE 3)

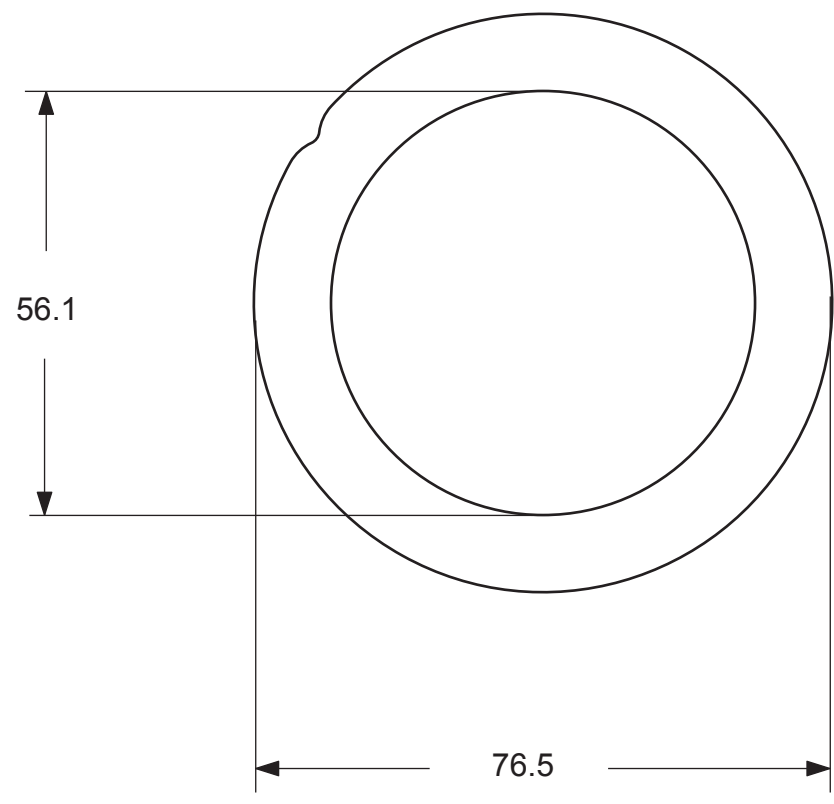
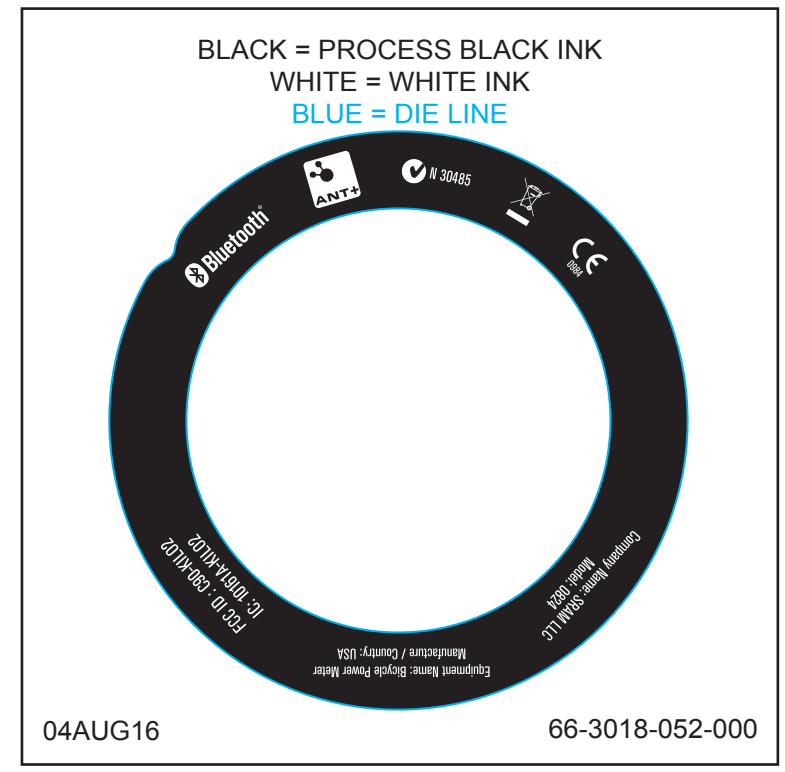

PART NUMBER	DESCRIPTION
66-3018-052-000	DECAL KILO BACK

Notes:

1. This graphic is silkscreen, die cut process.
2. Perform visual comparison of finished part against sample 66-3018-052-XXX and specification Grade 4 for first piece and in-process inspection.
3. Substrate is .020" velvet Lexan 8B35 with 3M 5mil F9469PC adhesive.
4. Art must be imageset on film, 800 dpi minimum.

DESIGNED BY: LORI CASTANUELA		FORMAT: A3	SHEET: 1/1
SRAM [®]			
CONFIDENTIAL - THIS DRAWING CONTAINS INFORMATION THAT IS PROPRIETARY TO SRAM CORPORATION AND MAY NOT BE DISCLOSED WITHOUT PERMISSION.			
DO NOT SCALE DRAWING		DRAWING NAME/DESCRIPTION	
ALL DIMENSIONS ARE mm		DECAL KILO BACK	
UNSPECIFIED LENGTH TOLERANCE X.X +/- 0.5		DRAWING NUMBER	
UNSPECIFIED ANGLE TOLERANCE +/- 2degrees		66-3018-052-XXX	
			REVISION
			B