

REV	RESPONSIBLE	REVISION RECORD
A	NSNYDER	RELEASE

A

A

B

B

C

C

D

D

E

E

F

F

G

G

BLACK = PROCESS BLACK (GLOSS)  
 LIGHT GREY = PANTONE COOL GREY 9 (GLOSS)  
 BLUE = DIE LINE  
 ORANGE = PREMASK AND CARRIER

SRAM LLC, M/N: 13888 MADE IN TAIWAN FCC ID: C50-F5MB2 IFETEL: YYYYYYYY-XXXX  
 SUBTEL: XXXXXX CMC ID: XX-99999 ANATEL: HHHH-AA-FFFFF IC: 10101A-F5MB2

25OCT19 66-4020-786-010

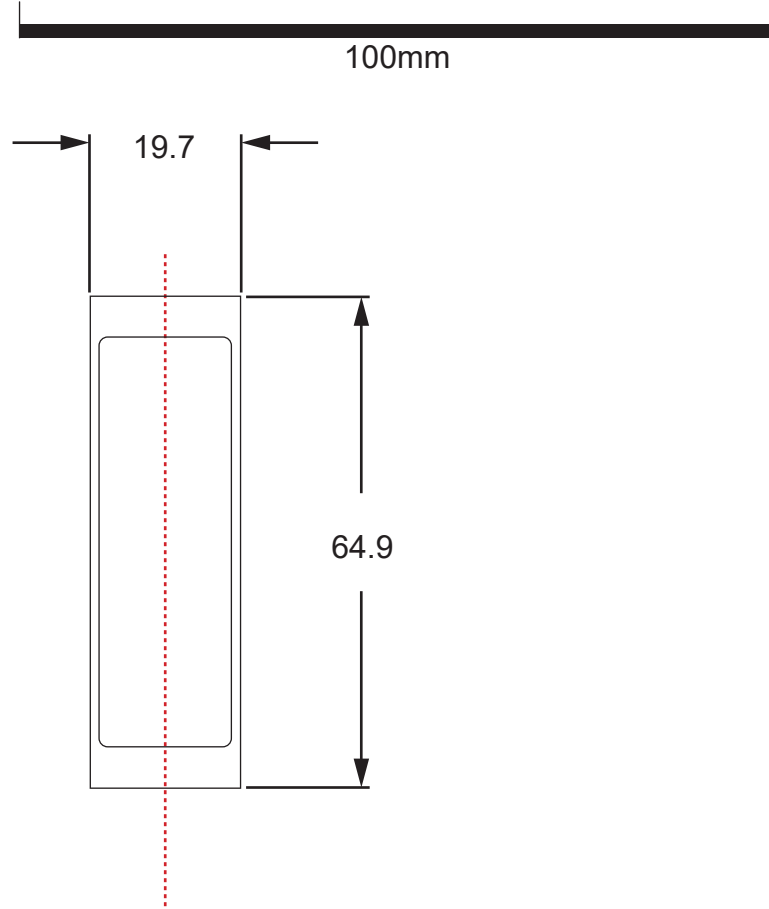

PART NUMBER	DESCRIPTION
66-4020-786-010	DECAL CERTS GRY/BLK

- NOTES:
1. RED DASHED LINE REPRESENTS LINE PRINTED ON PREMASK
  2. VERTICAL BACK SLIT SHOULD BE CENTERED ON PAPER BACKING

DOCUMENT MAY NOT REPRESENT COMPLETE REQUIREMENTS. REFER TO PRODUCT STRUCTURE

GEOMETRIC DIMENSIONING AND TOLERANCING TO BE INTERPRETED PER ASME Y14.5-2009	FORMAT: A3	SHEET: 1/1
DO NOT SCALE DRAWING	<b>SRAM</b> CONFIDENTIAL - THIS DRAWING CONTAINS INFORMATION THAT IS PROPRIETARY TO SRAM CORPORATION AND MAY NOT BE DISCLOSED WITHOUT PERMISSION.	
ALL DIMENSIONS ARE mm	DRAWING NAME/DESCRIPTION <b>DECAL CERTS</b>	
UNSPECIFIED LENGTH TOLERANCE X.X +/- 0.5	DRAWING NUMBER <b>66-4020-786-0XX</b>	REVISION <b>A</b>
UNSPECIFIED ANGLE TOLERANCE +/- 5degrees		