

REV	REVISION RECORD
A	RELEASE
B	CHANGE: SERIAL NUMBER NOTES (F9)
C	CHANGE: ARTWORK (C3)

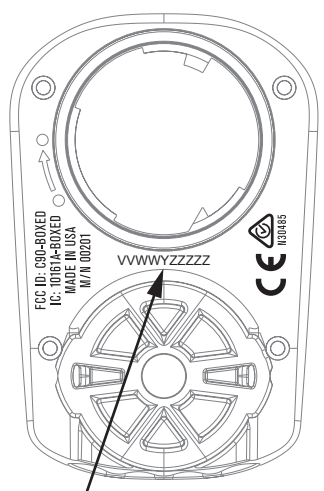

SERIAL NUMBER

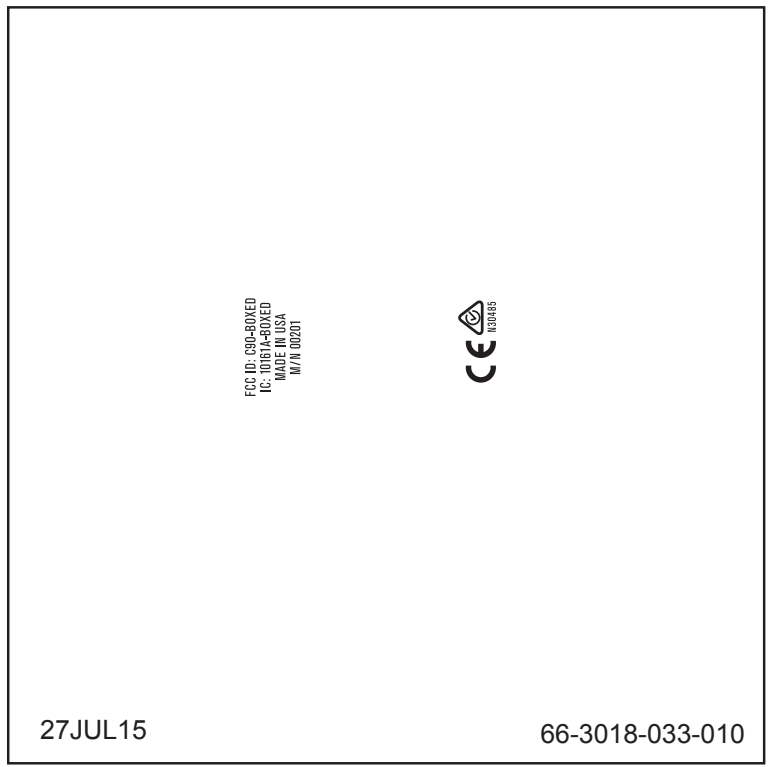
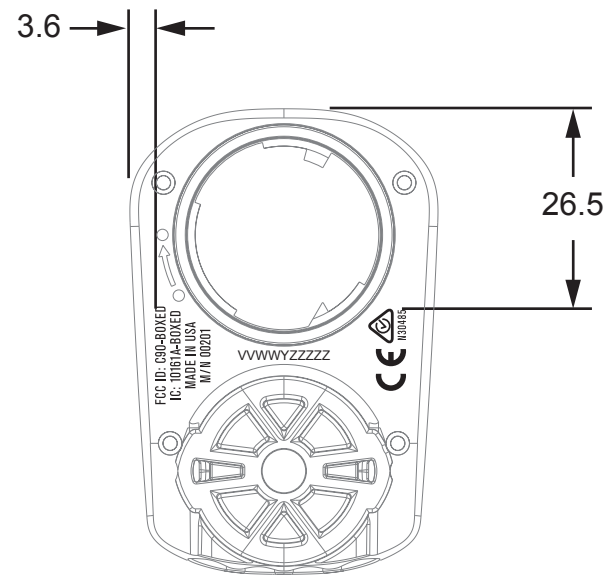

NOT TO SCALE

SERIAL NUMBER CONTAINS 10 DIGITS:
 VWWWYZZZZZ
 VV - 2 digit Source Code = Unique number
 Vendor starts from 41-20 (descending)
 In-House starts from 10-15 (ascending)
 OPEN 16-19 (for either vendor or in-house, as needed)
 WWY – Week Number and last digit of Year (manufacture date)
 ZZZZZ – Sequential Number

PART NUMBER	DESCRIPTION	PROCESS SPEC.
66-3018-033-010	ARTWORK CERTIFICATION BLIPBOX	67-8815-027-000

GEOMETRIC DIMENSIONING AND TOLERANCING TO BE INTERPRETED PER ASME Y14.5-2009 DO NOT SCALE DRAWING ALL DIMENSIONS ARE mm UNSPECIFIED LENGTH TOLERANCE X.X +/- 1.0 UNSPECIFIED ANGLE TOLERANCE +/- 5degrees	DESIGNED BY: CHRIS MAY	FORMAT: A3	SHEET: 1/1
	SRAM CONFIDENTIAL - THIS DRAWING CONTAINS INFORMATION THAT IS PROPRIETARY TO SRAM CORPORATION AND MAY NOT BE DISCLOSED WITHOUT PERMISSION.		
	DRAWING NAME/DESCRIPTION		
	ARTWORK CERTIFICATION BLIPBOX		
	DRAWING NUMBER		REVISION
66-3018-033-XXX		C	