

## 6. Specification of DAEWOO Magnetron of 2M218

▶ FCC ID : C5F7NF86MO1000 ◀



**DAEWOO**  
DAEWOO ELECTRONICS CO., LTD.

C.P.O. BOX 8003 SEOUL KOREA  
981-1 JANGDUCK-DONG  
KWANGSAN-KU, KWANG JU, KOREA  
TEL. : (062) 951-2000 ~ 9  
FAX. : (062) 951-2010

MAGNETRON DIVISION

TO :

APPROVAL SIGNATURE

# S P E C I F I C A T I O N

FOR  
DAEWOO MAGNETRON

2 M 2 1 8

*No-Hon Myong*

NO-HON MYONG  
MANAGER, MAGNETRON DEPT.

SPECIFICATION NO. :  
ISSUED :

S/C

2 M 2 1 8

This specification is based upon EIAJ ET-145A Testing Methods for Continuous Wave Magnetrons

DAEWQO CONTINUOUS WAVE MAGNETRON 2M218

DESCRIPTION	Magnetron (Fixed Frequency, Integral Magnet)									
FUNCTION	For Microwave Oven (2450MHz Band continuous wave oscillation)									
OUTER DIMENSIONS	See Outline drawing									
ABSOLUTE MAXIMUM RATINGS									NOTE(4)(5)	NOTE(4)
	TERM	Ef	tk	e <sub>bm</sub>	I <sub>b</sub>	i <sub>hm</sub>	P <sub>f</sub>	σ <sub>L</sub>	T <sub>o</sub>	T <sub>case</sub>
	UNIT	V	s	kV	mAdc	A	kW	-	°C	°C
	MAX.	3.75	-	4.5	350	1.2	1.4	4	250	100
	MIN.	2.80	0	-	-	-	-	-	-	-
STANDARD TEST CONDITION	NOTE (1)(2)(3)	3.30	-	-	300	-	-	1.1MAX	-	-

TEST SPECIFICATION

TEST TERM NOTE (8)	TEST METHOD EIAJ ET-145A	TEST CONDITION	SYMBOL	BOGIE	LIMIT		UNIT	
					MIN.	MAX.		
*** VIBRATION	5.4.1		-	-	-	-	-	
** BREAK DOWN VOLTAGE	4.2	NOTE (6)	-	-	-	-	-	
** INSULATION	4.2	E <sub>b</sub> =1kVdc R.H.MAX. 60%	-	-	100	-	MΩ	
** FILAMENT CURRENT	4.1.1	tk=120s	I <sub>f</sub>	10	8	12	A	
PEAK ANODE VOLTAGE	4.3.1	NOTE (7)	e <sub>bm</sub>	4.10	3.95	4.25	kV	
AVERAGE POWER OUTPUT(1)	4.3.3.1	NOTE (7)	P <sub>o</sub> (1)	925	885	965	W	
FREQUENCY	4.3.4		f	2458	2448	1468	MHz	
*** PULLING FIGURE	4.3.6	σ <sub>L</sub> = 1.5	f <sub>pl</sub>	-	-	15	MHz	
*** SINK PHASE	4.3.7		λ <sub>sink</sub> /λ <sub>g</sub>	0.25	-	-	-	
** STABILITY MODING (1)	4.3.11.2	σ <sub>L</sub> = 2,3,4; t=60s	-	-	-	-	-	
** FUNDAMENTAL FREQUENCY RADIATION	4.3.15	σ <sub>L</sub> = 4	S <sub>1</sub>	-	-	-	1 mW/cm <sup>2</sup>	
*** LIFE TEST	4.5.1		t	-	500	-	h	
*** LIFETEST END POINT	AVERAGE POWER OUTPUT (1)	4.3.3.1	NOTE (7)	P <sub>o</sub> (1)	-	710	-	W

SPEC. NO. :

DATE :

PAGE : 2/10

- NOTE (1) Prescribed R.F.Coupler (Refer to the attached chart) or the similar type must be used.
- (2) Forced air cooling (1000 l/min).
- (3) Single phase full wave rectifier without filter shall be used for power supply.
- (4) See outline drawing for measuring point.
- (5) Maximum saturated anode temperature for normal condition (with load in the cavity) should be 200°C.
- (6)  $E_b=10kVdc$  or  $7kVac$  ;  $t=60s$
- (7) The surrounding temperature will be settled at the value of 25°C and it's exchange rate should be  $-0.0027^\circ C$ .
- (8) Tests shall be classified as follows.

Class	Mark	Remarks
Production test	None	This test is intended to ensure if the production line is being processed in compliance with the standard, and shall be conducted on some typical characteristics which are considered to be affected by changes in the process.
Design test	***	This test is intended to ensure the standard design, and shall be conducted on such characteristics which are not affected by the ordinary production line as long as the design is maintained.
Type approval test	*****	This test is intended to ensure the compliance of the standard design with given specifications, and may be omitted unless a substantial change in the design is made.

2M218

# OUTLINE DRAWING

UNIT: mm

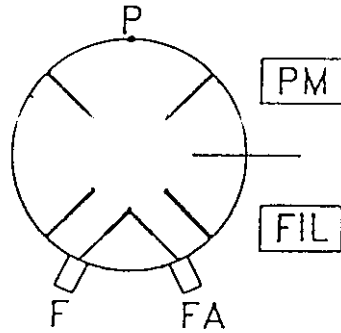
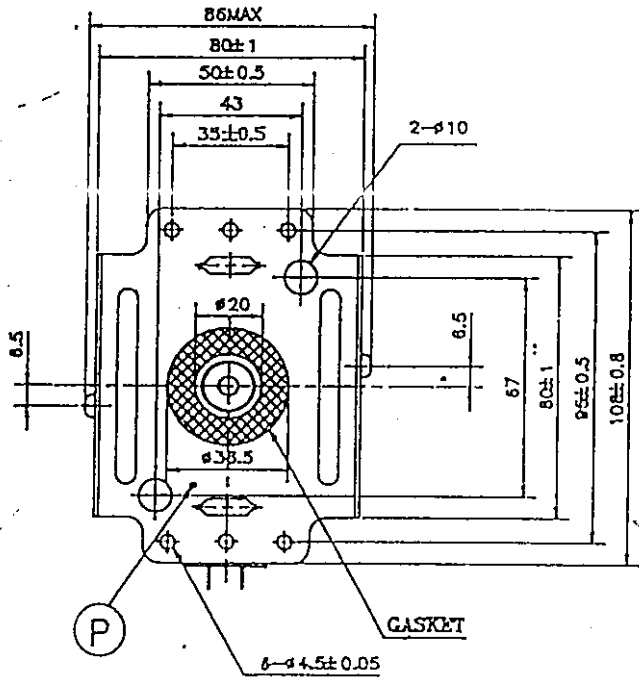

NOTE<1> TEMPERATURE TO BE MEASURED AT THE OUTLET SIDE OF AIRFLOW.

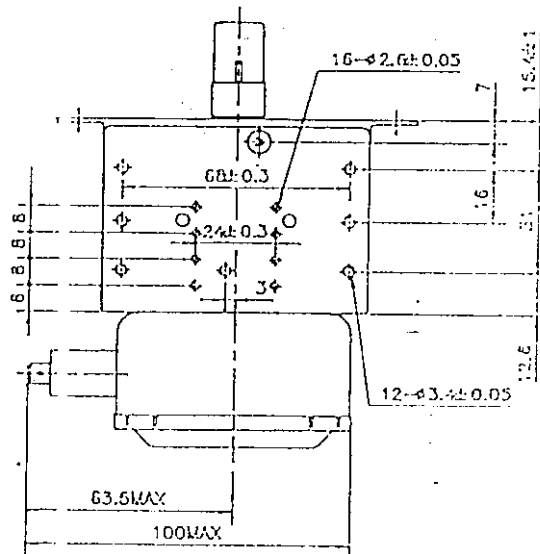
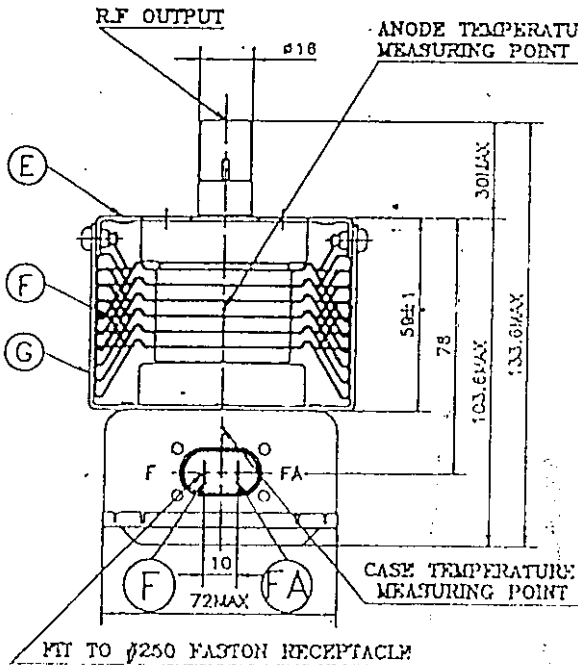

SPEC.NO.:

DATE:

PAGE: 4/10



# DETAILS OF FILTER CAPACITOR

UNIT : mm

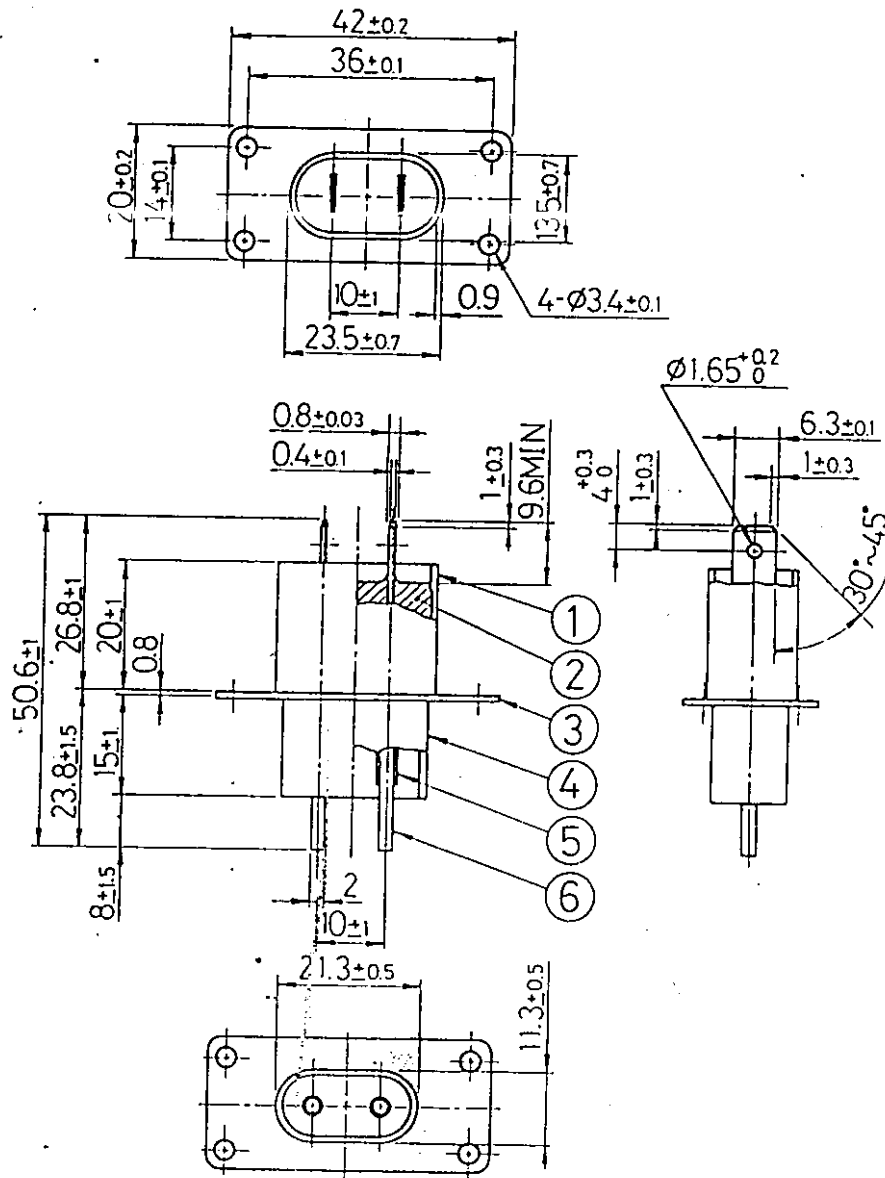

NOTE<1> THE FASTON TAB MEETS TO BS 5057 : 1973 AND DIN 46244 : APRIL 1980.

SPEC. NO. :

DATE:

PAGE : 6 / 10

2 M 2 1 8

## MATERIAL LIST

Part name	Manufacturer	Material	Manufacturer of Materials	U L - No.			Note
				Guide No.	File No.	Grade No.	
A Capacitor (HFC-2S-1)	T D K Corporation	1 Polybutylene terephthalate	Mitsubishi Rayon Co., LTD.	QMFZ2	E54695(N)	G2930	200,000 VOLTAGE
		2 Epoxy Resin	TDK Corporation	-	-	R-2, R-3	
		3 Steel	TDK Corporation	-	-	-	
		4 Polybutylene terephthalate	Dai-icastic Co., LTD.	QMFZ2	E45034(M)	2910	
		5 Silicone Rubber Tube	Shin-etsu Chemical Co., LTD. Toshiba Silicone Co., LTD.	-	-	5609 5033	
		6 Steel	TDK Corporation	-	-	-	

Part name	Manufacturer	Material	Thickness Diameter (mm)	Size (mm)	Note
B Choke coil	Dong An Corporation	Ferrite	-	15 x 16	9.5 turns 1.5 #1 x 2
		Enameled copper wire	φ 1.4		
C Shielding case	Daewoo Electronics Co., LTD.	Zinc steel	T 0.4	70 x 70	
D Shielding case cover	do	do	T 0.4	71 x 71	
E Heat sink enclosure (1)	do	do	T 0.4	-	
F Heat sink	do	Aluminium	T 0.7	80 x 80	6 fins
G Heat sink enclosure (2)	do	Zinc steel	T 1.4	-	

SPEC. NO. :

DATE :

PAGE : 7/10





R. F. COUPLER

UNIT : mm

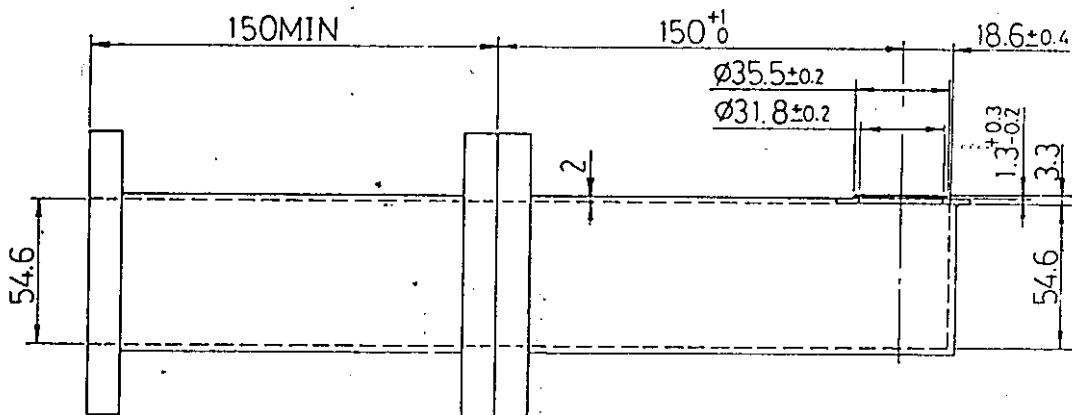
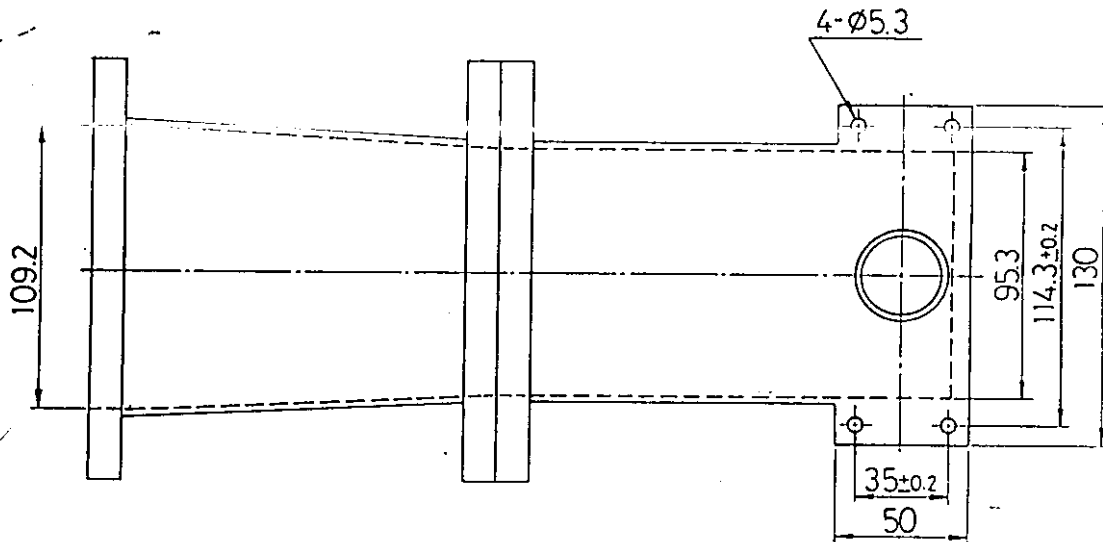

STANDARD R.F. COUPLER DEFINED BY E.I.A.J.

SPEC. NO. :

DATE :

PAGE : 9/10

LABEL

LABEL

The Label as shown below shall be put on each tube.

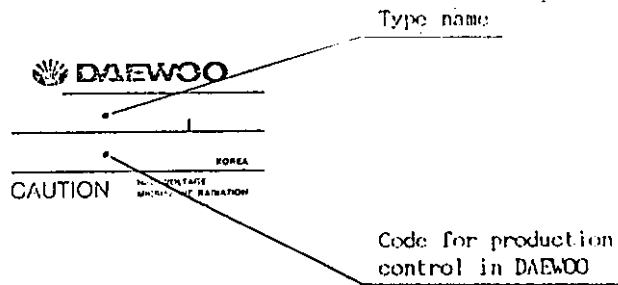

## 7. Specification of TOSHIBA Magnetron of 2M254

▶ FCC ID : C5F7NF86MO1000 ◀

# TOSHIBA

TOSHIBA HOKUTO ELECTRONICS CORPORATION  
MAGNETRON QUALITY ASSURANCE GROUP, MAGNETRON DIVISION  
1975, 23-CHOME MINAMI 5-JODORI, ASAHIKAWA, HOKKAIDO 078, JAPAN  
PHONE (0166) 31-8500 FACSIMILE (0166) 31-8209

To : DAEWOO ELECTRONICS CO., LTD.

APPROVAL SIGNATURE

## SPECIFICATION

FOR  
MAGNETRON  
2M254



Yoichi Terabayashi

MANAGER,  
MAGNETRON QUALITY ASSURANCE GROUP  
MAGNETRON DIVISION

SPECIFICATION NUMBER	: E960014-D01	January 24, 1996
REVISION STATUS	: REVISION A	February 28, 1996
	REVISION B	June 21, 1996
	REVISION C	July 17, 1997
	REVISION D	June 16, 1998

#### REFERENCE FOR THIS SPECIFICATION

MAGNETRON ENGINEERING DEPARTMENT  
1975, 23-CHOME, MINAMI 5-JODORI, ASAHIKAWA, HOKKAIDO 078, JAPAN  
PHONE : (0166) 31-4728 FACSIMILE : (0166) 35-5671

# MAGNETRON SPECIFICATION

This specification is based on the testing methods for continuous wave magnetrons ED-1501 set by the Electronic Industries Association of Japan (EIAJ).

Continuous Wave Magnetron												
DESCRIPTION	Magnetron (Fixed Frequency, Integral Magnet, Forced Air Cooled)											
FUNCTION	2450 MHz band continuous wave oscillation											
OUTER DIMENTIONS	See outline drawing											
ABSOLUTE MAXIMUM RATINGS		(°)	(°)	(°)	(°)	(°)	(°)	(°)	(°)	(°)	(°)	(°)
	Term	Ef	tk	ebm	lb	ibm	Pi	$\sigma_L$	Tp	Tcase	Tstorage	Tseal
	Unit	V	s	kV	mAdc	A	kW	-	°C	°C	°C	°C
	Max	3.75	-	4.5	350	1.2	1.4	4	300	100	60	320
Min	2.85	0	-	-	-	-	-	-	-	-30	-	
STANDARD TEST CONDITION: (°)	3.3	5	-	300	-	-	1.1Max	-	-	-	-	-
TEST SPECIFICATIONS												
TEST TERM (°)	TEST METHOD (EIAJ ED-1501)	TEST CONDITION	SYMBOL	BOGIE	LIMIT		UNIT					
					Min	Max						
** Vibration	5.4.1		-	-	-	-	-					
Breakdown Voltage	4.2	EI=10kVdc or 8kVac (rms)	-	-	-	-	-					
Insulation	-	EI=1kVdc (°)	-	-	-	-	-					
* Cold Start Voltage Transient	-	(°)	-	-	-	-	kV					
* Filament Current	4.1.1	tk=120s	If	10.5	8.5	12.5	A					
Peak Anode Voltage	4.3.1	(°)	ebm	4.20	4.05	4.40	kV					
Average Output Power (1)	4.3.3.1	(°)	Po	900	860	940	W					
* Average Output Power (2)	4.3.3.2	$\sigma_L=4$ , Power Min (°)	Po	-	510	-	W					
Frequency	4.3.4	(°)	f	2460	2450	2470	MHz					
* Stability/Moding	4.3.11.2	$\sigma_L=2,3,4$	-	-	-	-	-					
* Stability/Runaway	4.3.11.1	$\sigma_L=6$ , t=30s	-	-	-	-	-					
* Pulling Factor	4.3.6	$\sigma_L=2$	fpl	-	-	26	MHz					
* Sink Phase	4.3.7	$\sigma_L=2$	$\lambda^{sink} / \lambda_g$	0.200	-	-	-					
** Life Test	4.5.1	(°)	t	-	500	-	h					
** Life Test End Point	Average Output Power (1)	4.3.3.1	(°)	Po	-	680	-	W				
	Stability/ Moding	4.3.11.2	$\sigma_L=2,3,4$	-	-	-	-					
	Stability/ Runaway	4.3.11.1	$\sigma_L=6$ , t=30s	-	-	-	-					

## MAGNETRON SPECIFICATION

Note (1) The tube shall be mounted on the output coupler (containing tapered waveguide) shown in the attached drawing (Page-4) and cooled by forced air of 800 #/min. Single phase full wave rectifier without filter shall be used for power supply. The diagram of the test equipment is shown in the attached drawing (Page-3).

- (2) During normal oscillation.
- (3) The points for measuring anode temperature is shown in the outline drawing. Maximum anode temperature for normal condition (with load in the cavity) should be 250 °C
- (4) The point for measuring filter case temperature is shown in the outline drawing.
- (5) Tseal means temperature of ceramic-to-metal seal position of the tube. Maximum allowable build-up curve of seal temperature is shown in the attached drawing (Page-5).
- (6) Tests shall be classified as follows:

Class	Mark †	Remarks
Production test	None	This test is intended to ensure if the production line is being processed in compliance with the standard, and shall be conducted on some typical characteristics which are considered to be affected by changes in the process.
Design test	*	This test is intended to ensure the standard design, and shall be conducted on such characteristics which are not affected by the ordinary production line as long as the design is maintained.
Type approval test	**	This test is intended to ensure the compliance of the standard design with given specifications, and may be omitted unless a substantial change in the design is made.

† : The Mark is placed on the left of each test item, for instance, \*\*Vibration

- (7) See the attached drawing (Page-5, Insulation).
- (8) Measurement shall be conducted by standard oven which has a single phase half wave doubler power supply without filter, where no load voltage of the transformer shall be less than 2.2 kV rms. The voltage transient just before start of oscillation shall be measured.
- (9) Measurement shall be conducted within 15 seconds after anode power is turned on. Magnetron is kept in the constant ambient temperature for more than 4 hours before testing. Standard ambient temperature is 25 °C. Correction factor of peak anode voltage (ebm) and output power (Po) vs. temperature is shown in the attached drawing (Page-5).
- (10) For each oven model, both microwave oven manufacturer and Toshiba Hokuto should evaluate and agree on the stability characteristics in the design stage of the oven.
- (11) The tube shall not appreciably be damaged in the following abnormal test.

Condition:

Anode temperature (Tp)	Cycle (Time)	Corresponding operating condition
350 °C MAX	5 cycles (15minutes/cycle)	No Load

# MAGNETRON SPECIFICATION

## TEST EQUIPMENT

### A. Waveguide configuration

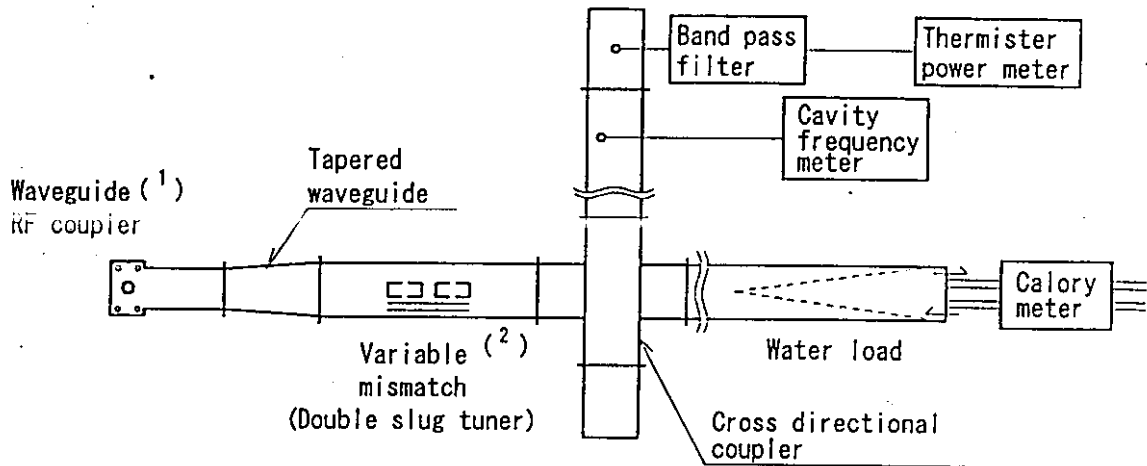

**Note**

- (1) Details are shown in the attached drawing (Page-4).
- (2) Calibrated with the standard standing wave detector.
- (3) WR430 waveguides are used from the double slug tuner to the water load.

### B. Power supply connection

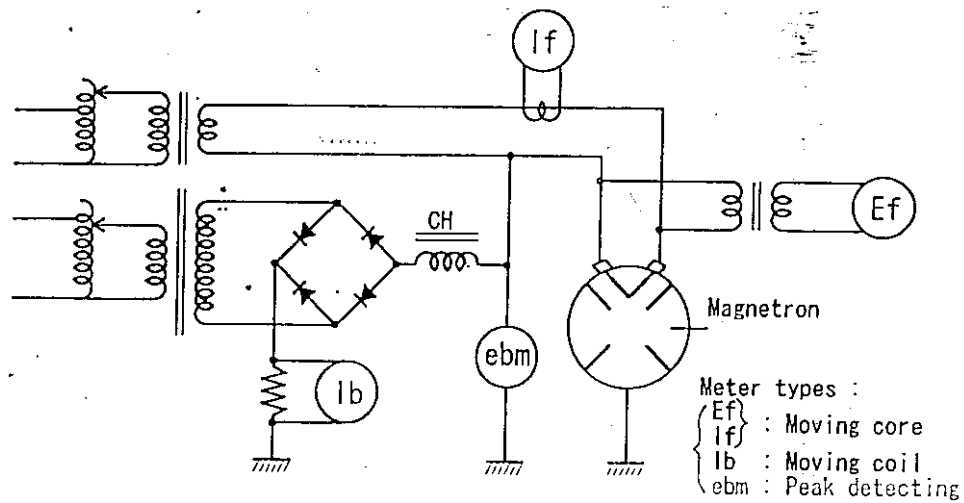

**Note**

- (1) Choke coil is adjusted such that the peak anode current value becomes three times the average value.



# MAGNETRON SPECIFICATION

## FILAMENT CONNECTION

To minimize possible transient voltage, the terminals (F) and (FA) should be connected to the transformer in such a way that the anode voltage increases and anode current decreases compared with those for reversed connection when a single phase half wave doubler without filter is used as a power supply.

## OUTPUT COUPLER (The output coupler used in Toshiba Hokuto inspection)

Unit : mm

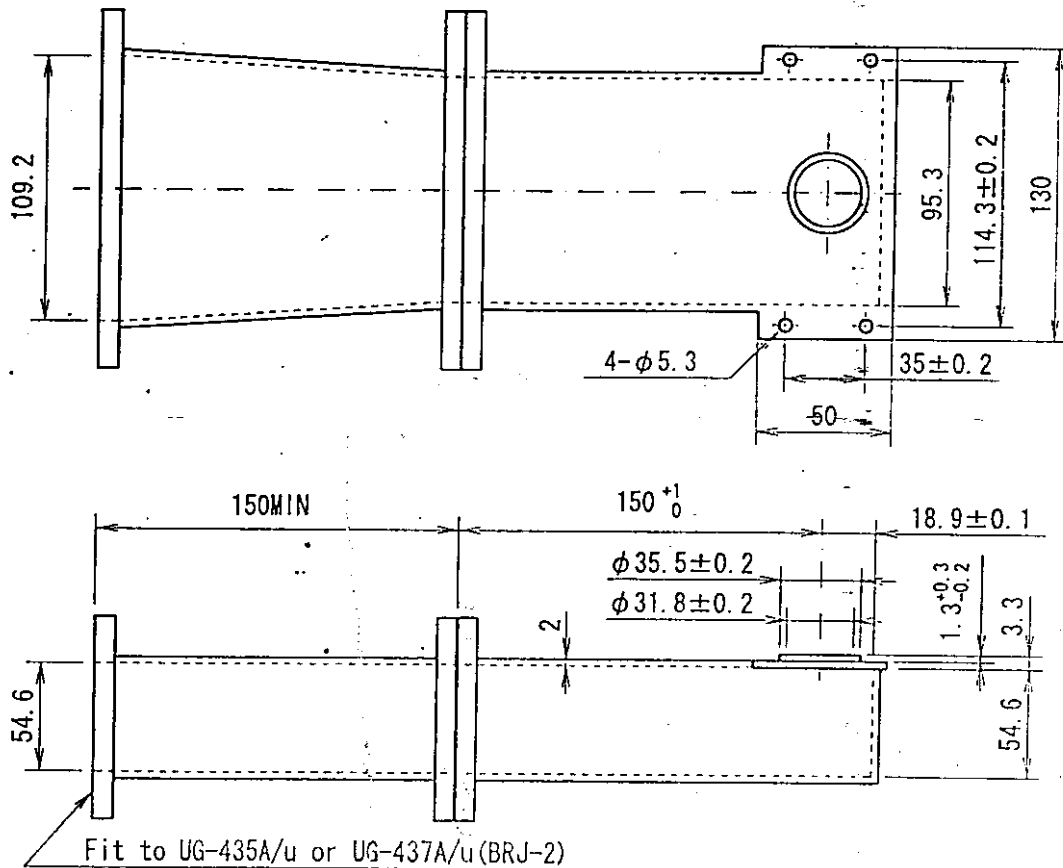

# MAGNETRON SPECIFICATION

MAXIMUM ALLOWABLE BUILD-UP CURVE OF SEAL TEMPERATURE

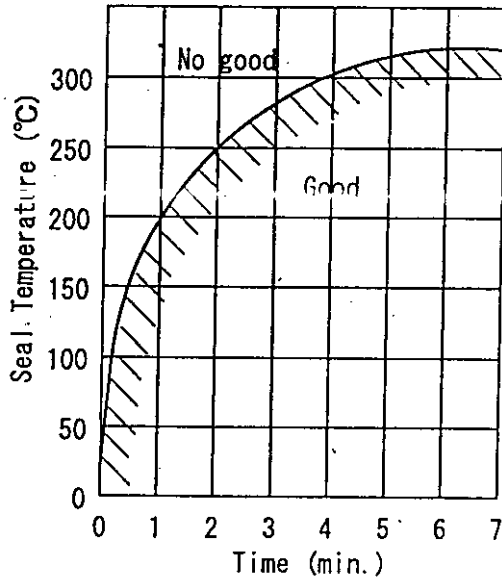

INSULATION

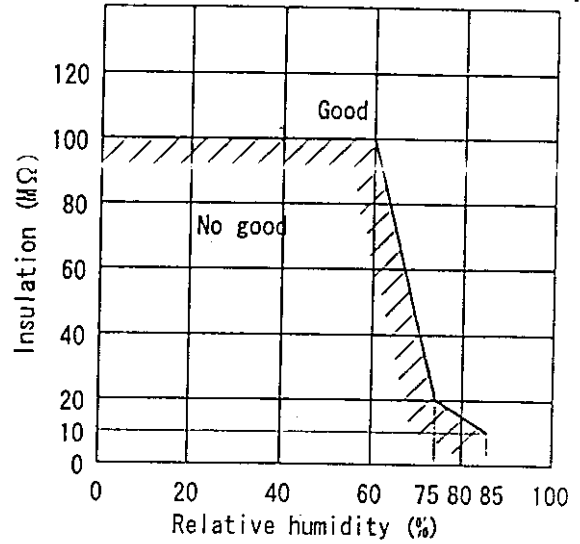

CORRECTION FACTOR OF PEAK ANODE VOLTAGE (ebm) AND OUTPUT POWER (Po) VS. AMBIENT TEMPERATURE

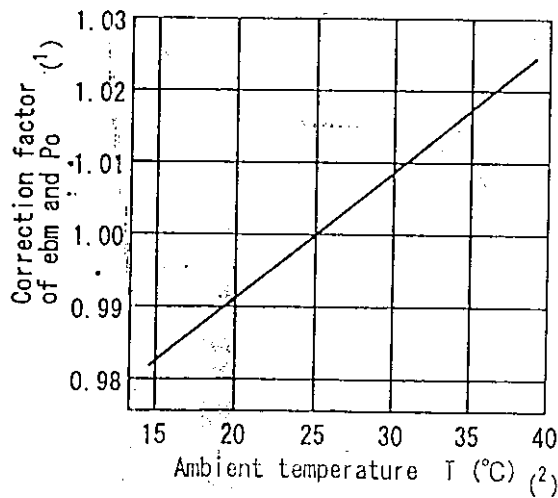

**Note**

- (1)  $ebm \text{ (or } P_o) \text{ measured at } T \text{ } ^\circ\text{C} \times \text{Correction factor at } T \text{ } ^\circ\text{C} = ebm \text{ (or } P_o) \text{ at } 25 \text{ } ^\circ\text{C}$
- (2) The temperature shown in this figure is the constant room temperature in which the magnetron has been kept for more than 4 hours before testing.

# MAGNETRON SPECIFICATION

OUTLINE DRAWING (Made in JAPAN)

Unit : mm

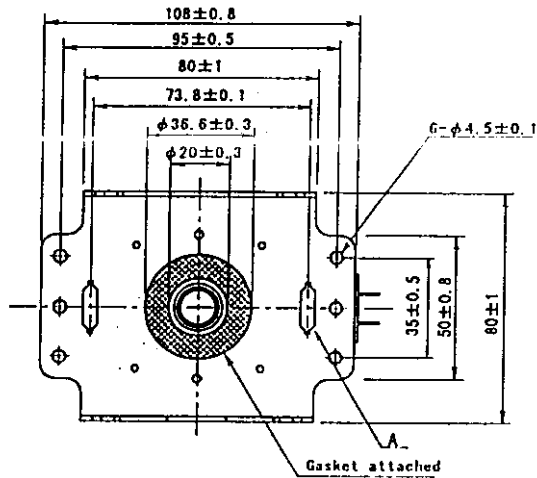

Note(1) Temperature to be measured at the outlet side of air flow.

(2) Refer filament connection.

(3) "F" and "FA" are marked at these positions.

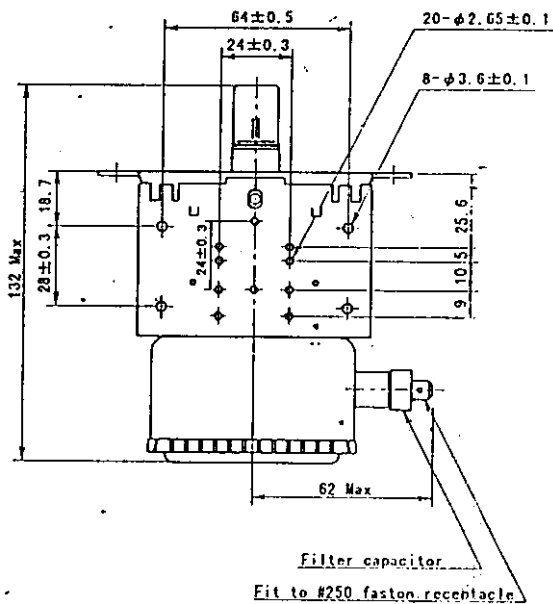

DETAIL A

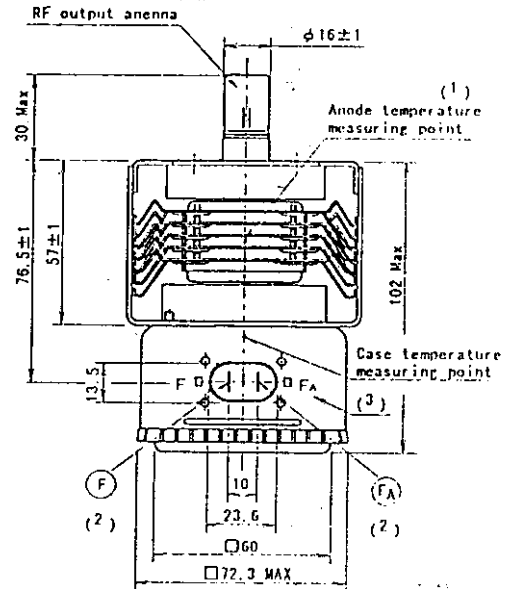
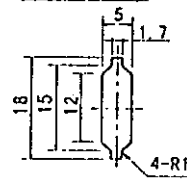

# MAGNETRON SPECIFICATION

## OUTLINE DRAWING (Made in UK)

Unit : mm

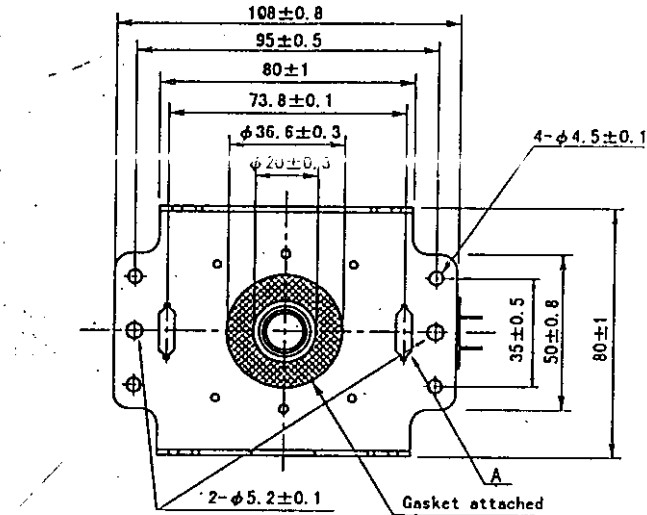

Note(1) Temperature to be measured at the outlet side of air flow.

(2) Refer filament connection.

(3) "F" and "FA" are marked at these positions.

### DETAIL A

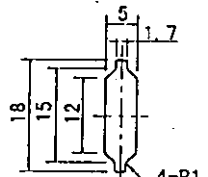

RF output antenna

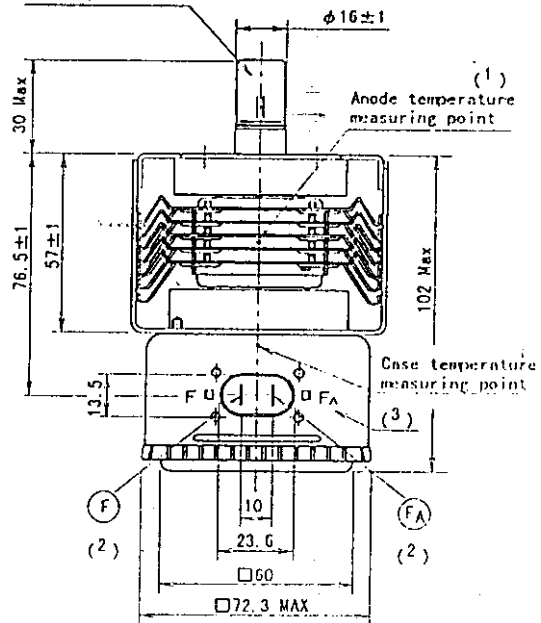
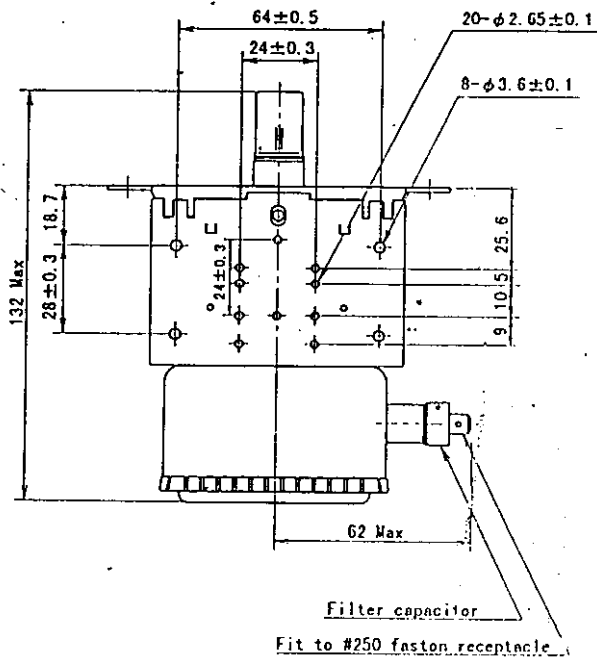

# MAGNETRON SPECIFICATION

## LABEL

The label as shown below shall be put on each tube.

The code stamped on the indicated position of each label consists of three block numbers ;

The first block is the serial number of tube with data. The second block is the date code in which the preceding one numerals shows the last of Christian Era and the continuing block letter and two numerals indicate the three months after the scheduled date of shipment from Japan or UK.

The third block is the numerals only, for the production control in Toshiba Hokuto.

Type name

Serial number of (1) tube with data

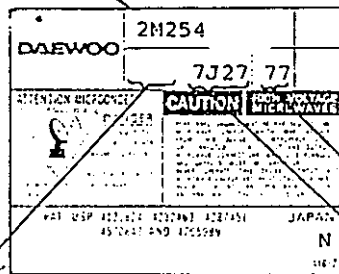

Code for production control in Toshiba Hokuto

Date code  
 A : January  
 B : February  
 C : March  
 D : April  
 E : May  
 F : June  
 G : July  
 H : August  
 J : September  
 K : October  
 L : November  
 M : December

Note

(1) In case of a sample requirement only

Sample

(Made in Japan)

(Made in UK)

Labeling

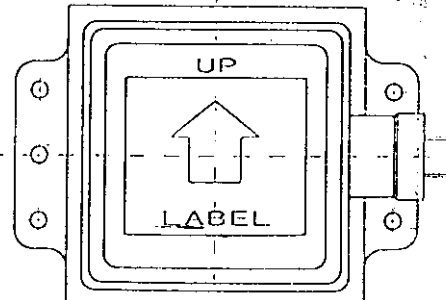
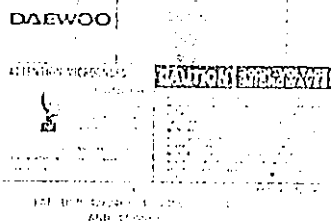
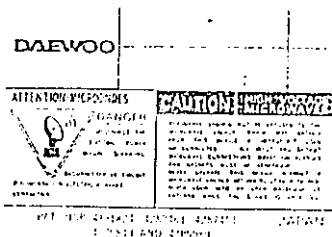

# MAGNETRON SPECIFICATION

## SPACING IN THE FILTER BOX

Unit : mm

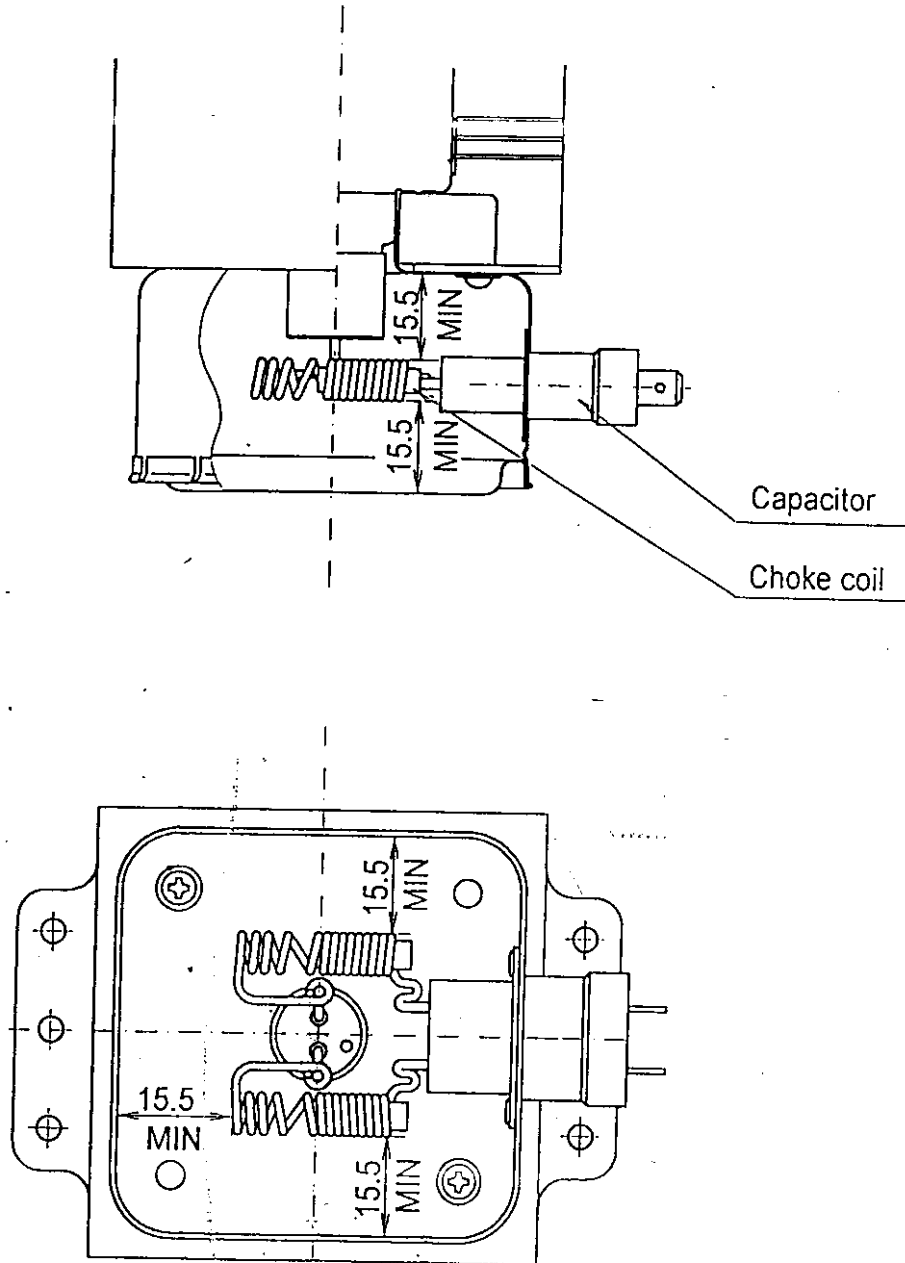

# MAGNETRON SPECIFICATION

## DETAILS OF FILTER CAPACITOR

Unit : mm

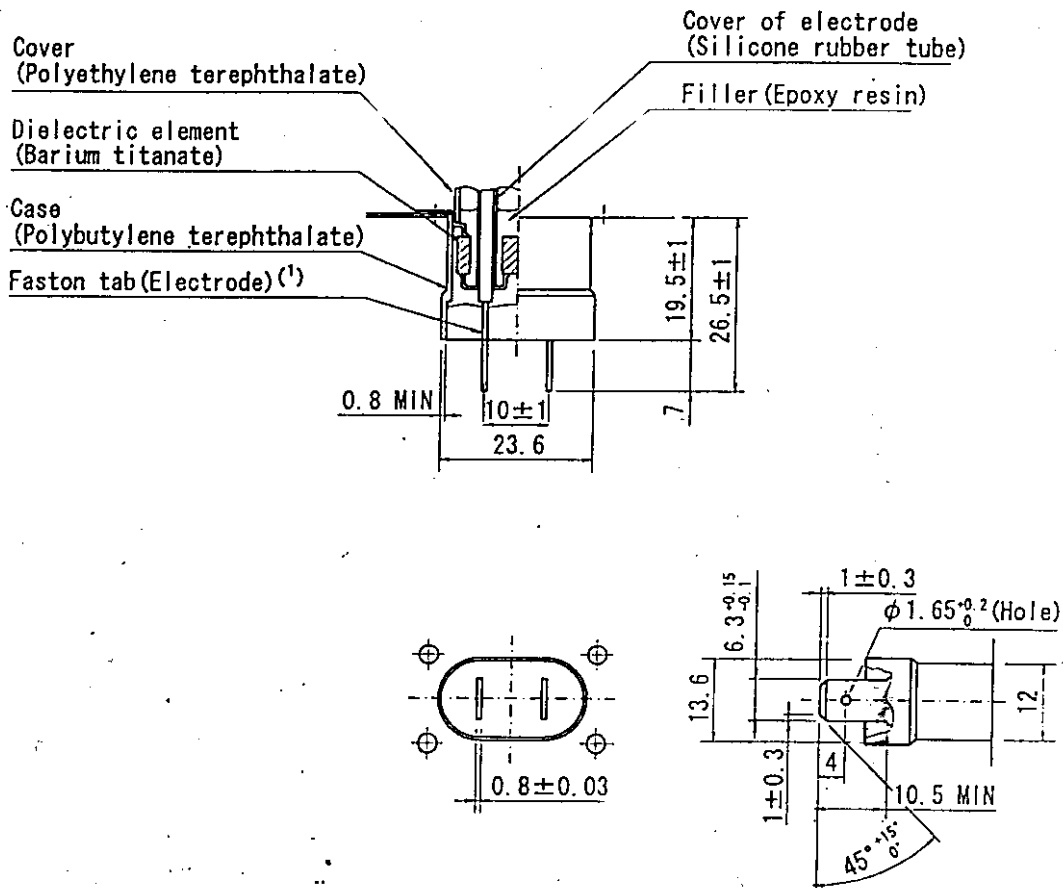

Note

(1) The faston tab meets to BS 5057 ; 1973 and DIN 46 244 ; April 1980.

# MAGNETRON SPECIFICATION

## INSULATING MATERIAL (Refer Page-8 & 9)

Part Name	Catalog No./ Manufacturer (2)	Material	Manufacturer of Materials	UL No. (1)		
				Guide No.	File No.	Grade No.
Capacitor	Toshiba Hokuto Spec.	Barium Titanate	TDK Corp.	-	-	-
		Epoxy Resin	Ditto	-	-	-
	HFC-2L-3/ TDK Corp.	Silicone Rubber Tube	Shin-etsu Chemical Co., Ltd. or Toshiba Silicone Co., Ltd.	-	-	-
		Polyethylene Terephthalate	Teijin Ltd.	QMF-Z2	E52857M	CN9015
		Polybutylene Terephthalate	Mitsubishi Rayon Co., Ltd.	QMF-Z2	E54695M	G2930
Choke coil	Toshiba Hokuto Spec.  Marusan Corporation. or Kokusan Bane Co., Ltd.	Ferrite	Tomita Electric Co., Ltd. or Hitachi Ferrite Co., Ltd. or Fuji Denki Kagaku Co., Ltd. or NWE Industrial Co., Ltd.	-	-	-
		Formal Coated Wire	Daichi Denko Co., Ltd. or Showa Electric Wire & Cable Co., Ltd. or TAI-I Electric Wire & Cable Co., Ltd.	-	-	-
		Silicone Rubber	Toshiba Silicone Co., Ltd.	-	-	-

Note

- (1) UL No. is for the material.
- (2) One of them shall be used by Toshiba Hokuto's option.



# MAGNETRON SPECIFICATION

## FILTER CIRCUIT

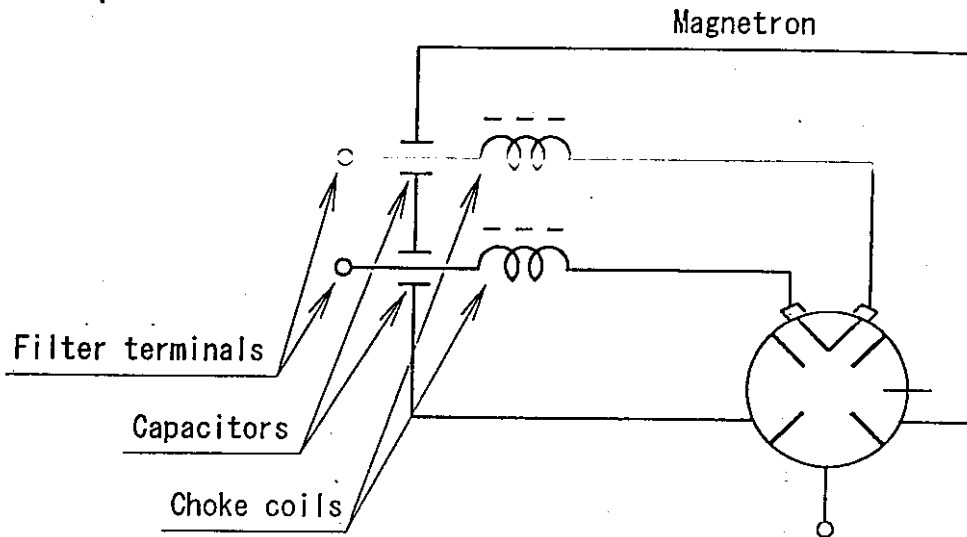

## RATING

	Nominal value	Remarks
Capacitor	500pF×2 WV 10kVdc	
Choke coil (13.5 turns)	1.2μH×2	at about 8MHz

# MAGNETRON SPECIFICATION

## GASKET

Unit : mm

Material : Woven and press formed brass wire

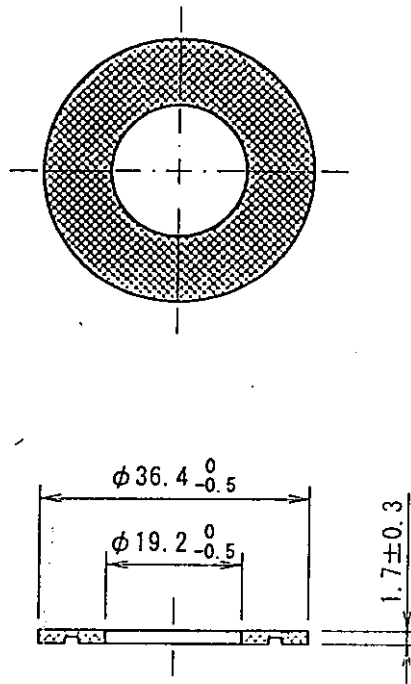

Inspection : By using thick-part of slide calipers

## MAGNETRON SPECIFICATION

### PRECAUTIONS FOR SAFETY

Carefully take the following precautions for safety in using the magnetrons for microwave ovens or for other applications.

Magnetrons must be handled by individuals possessing adequate backgrounds of electrical, electronic, microwave and mechanical experience.

Toshiba Hokuto Electronics Corporation cannot be responsible for the interpretation of this information, nor can it be assumed any liability in connection with its use.

#### 1. High Voltage

Since the magnetron is operated with negative high potential at the cathode terminals, a special care must be taken as follows.

- 1-1 Do not touch nor come close to the cathode terminals or their surroundings during operation.
- 1-2 To avoid shock hazards, never insert metallic wire or like into the filter box, and never operate the magnetron with the lid of filter box open.
- 1-3 Before removing the magnetron from the oven, carefully check that power is turned off, and discharge the cathode terminal or the capacitors in the power supply circuit by using the discharging rod adequately designed for safety.

#### 2. Radiation Leakage

Care should be taken for radiation leaked from the magnetron, though the leakage from the input part of magnetron is restricted to a level which human body is not adversely affected.

- 2-1 Properly install and tightly fasten the magnetron in the oven or in the waveguide coupler.
- 2-2 Do not deform the gasket or do not operate the magnetron with the gasket removed, to avoid hazardous conditions such as radiation leakage and arcing.
- 2-3 Never operate the magnetron without installing it in the oven or with the output antenna exposed.
- 2-4 Do not remove the lid of the filter box nor deform the filter box.
- 2-5 Always keep your eyes apart from the operating magnetron in consideration of the unexpected hazardous conditions.

#### 3. Temperature

Although the magnetron is subjected to forced air cooling during operation, high temperature (sometimes more than 200 °C) is observed on the enclosure of magnetron. Care should be taken as follows.

- 3-1 Do not touch the magnetron immediately after turning power off. Allow the magnetron to cool before handling.
- 3-2 Putting on cotton gloves or the equivalents is recommended for safe handling.

#### 4. Alteration

Do not alter the magnetron.

## MAGNETRON SPECIFICATION

### Factories

- (1) Toshiba Hokuto Electronics Corporation  
23-chome 1975, Minami 5-jo, Asahikawa, 078, Japan  
Phone : (0166) 31-4728  
Facsimile : (0166) 35-5671
  
- (2) Toshiba Consumer Products (U.K.) Ltd.,  
Northholt Avenue, Emesettle, Plymouth, Devon, England, PL5 2TS  
Phone : (01752) 208549  
Facsimile : (01752) 205270

# MAGNETRON SPECIFICATION

## RECORD OF REVISION

Original Specification : E960014-D01 January 24, 1996

STATUS	PAGE	REVISION	NOTES	EFFECTIVE DATE
Revision A	7	LABEL Change of Label	As per Daewoo's request	February 28, 1996
Revision B	6	Addition of holes for mounting thermoswitch	As per Toshiba Hokuto's request	June 21, 1996
		Length from antenna top to filter box lid 131MAX → 132MAX	Correction	
		Length from yolk to filter box lid 101MAX → 102MAX		
Revision C	1	TEST CONDITION of Average Output Power(1) Bogie ; 890→ 900 , Min ; 850→ 860 Max ; 930→ 940	Correction	July 17, 1997
	7	LABEL Addition of Label made in UK	As per Daewoo's request	
	14	Addition of factories	As per Daewoo's request	
Revision D	2	Change of LIFE TEST CONDITION 320°C MAX → 350°C MAX	As per Toshiba Hokuto's request	July, 1998
	6	Change of title Outline drawing (Made in Japan)	Change of hole size (made in UK only)	
	6-1	Addition of page Outline drawing (Made in UK)		
		<del>Change of page</del>	<del>Due to addition of page</del>	

# TOSHIBA

TOSHIBA HOKUHO ELECTRONICS CORPORATION  
MAGNETRON ENGINEERING DEPARTMENT  
1975, 23-CHOME, MINAMI 5-JODORI, ASAHIKAWA, HOKKAIDO 078, JAPAN  
PHONE: (0166) 31-4728 FACSIMILE: (0166) 35-5671

To: DAEWOO ELECTRONICS CO., LTD.

APPROVAL SIGNATURE

## SPECIFICATION

FOR

MAGNETRON

2M248



Hisao Salto

SENIOR MANAGER,

MAGNETRON ENGINEERING DEPARTMENT

SPECIFICATION NUMBER : E06007-D01

April 14, 1994

REVISION STATUS :

# MAGNETRON SPECIFICATION

CONFIDENTIAL

This specification is based on the testing methods for continuous wave magnetrons ED-1501 set by the Electronic Industries Association of Japan (EIAJ).

Continuous Wave Magnetron													
DESCRIPTION		Magnetron (Fixed Frequency, Integral Magnet, Forced Air Cooled)											
FUNCTION		2450 MHz band continuous wave oscillation											
OUTER DIMENSIONS		See outline drawing											
ABSOLUTE MAXIMUM RATINGS			( <sup>1</sup> )	( <sup>10</sup> )	( <sup>1</sup> )	( <sup>1</sup> )							
		Term	Ef	tk	ebm	lb	ibm	Pi	$\sigma_L$	Tp	Tcase	Tstorage	Tseal
		Unit	V	s	kV	mAdc	A	kW	-	°C	°C	°C	°C
		Max	3.60	-	4.85	380	1.5	1.7	4	300	100	60	320
Min	2.70	0	-	-	-	-	-	-	-	30	-	-	
STANDARD TEST CONDITION: ( <sup>1</sup> )		3.15	5	-	330	-	-	1.1Max	-	-	-	-	
TEST SPECIFICATIONS													
TEST TERM ( <sup>1</sup> )	TEST METHOD (EIAJ ED-1501)	TEST CONDITION	SYMBOL	BOGIE	LIMIT		UNIT						
					Min	Max							
** Vibration	5.4.1		-	-	-	-	-						
Breakdown Voltage	4.2	Et=10kVdc or 8kVac (rms)( <sup>11</sup> )	-	-	-	-	-						
Insulation	-	Et=1kVdc ( <sup>1</sup> )	-	-	-	-	-						
* Cold Start Voltage Transient	-	( <sup>1</sup> )	-	-	-	8.5	kV						
* Filament Current	4.1.1	tk=120s	If	10.0	8.0	12.0	A						
Peak Anode Voltage	4.3.1	( <sup>1</sup> )	ebm	4.35	4.15	4.55	kV						
Average Output Power (1)	4.3.3.1	( <sup>1</sup> )	Po	1020	970	1070	W						
* Average Output Power (2)	4.3.3.2	$\sigma_L=4$ , Power Min ( <sup>1</sup> )	Po	-	540	-	W						
Frequency	4.3.4	( <sup>1</sup> )	f	2460	2450	2470	MHz						
* Stability/Moding (1)	4.3.11.2	$\sigma_L=2,3,4$	-	-	-	-	-						
Stability/Moding (2)	4.3.11.2	$\sigma_L=3$ , ibm=0.85A t=15s	-	-	-	-	-						
* Stability/Runaway	4.3.11.1	$\sigma_L=6$ , t=30s	-	-	-	-	-						
* Pulling Factor	4.3.6	$\sigma_L=2$	fpl	-	-	21	MHz						
* Sink Phase	4.3.7	$\sigma_L=2$	$\lambda_{sink} / \lambda_g$	0.235	-	-	-						
** Life Test	4.5.1		t	-	500	-	h						
** Life Test End Point	Average Output Power (1)	4.3.3.1	( <sup>1</sup> )	Po	-	770	-	W					
	Stability/Moding	4.3.11.2	$\sigma_L=2,3,4$	-	-	-	-						
	Stability/Runaway	4.3.11.1	$\sigma_L=6$ , t=30s	-	-	-	-						

# MAGNETRON SPECIFICATION

## Note

- (1) The tube shall be mounted on the output coupler (containing tapered waveguide) shown in the attached drawing (Page-5) and cooled by forced air of 800g/min. Single phase full wave rectifier without filter shall be used for power supply. The diagram of the test equipment is shown in the attached drawing (Page-4).
- (2) During normal oscillation.
- (3) The point for measuring anode temperature is shown in the outline drawing. Maximum anode temperature for normal condition (with load in the cavity) should be 250°C.
- (4) The point for measuring filter case temperature is shown in the outline drawing.
- (5) Tseal means temperature of ceramic-to-metal seal position of the tube. Maximum allowable build-up curve of seal temperature is shown in the attached drawing (Page-6).
- (6) Tests shall be classified as follows:

Class	Mark <sup>†</sup>	Remarks
Production test	None	This test is intended to ensure if the production line is being processed in compliance with the standard, and shall be conducted on some typical characteristics which are considered to be affected by changes in the process.
Design test	*	This test is intended to ensure the standard design, and shall be conducted on such characteristics which are not affected by the ordinary production line as long as the design is maintained.
Type approval test	**	This test is intended to ensure the compliance of the standard design with given specifications, and may be omitted unless a substantial change in the design is made.

† : The mark is placed on the left of each test item, for instance,  
\* Insulation.

- (7) See the attached drawing (Page-6, Insulation).
- (8) Measurement shall be conducted by standard oven which has a single phase half wave doubler power supply without filter, where no load voltage of the transformer shall be less than 2.2 kV rms. The voltage transient just before start of oscillation shall be measured.
- (9) Measurement shall be conducted within 15 seconds after anode power is turned on. Magnetron is kept in the constant ambient temperature for more than 4 hours before testing. Standard ambient temperature is 25°C. Correction factor of peak anode voltage (ebm) and output power (Po) vs. temperature is shown in the attached drawing (Page-6).
- (10) For each oven model, both microwave oven manufacturer and Toshiba Hokuto should evaluate and agree on the stability characteristics in the design stage of the oven.



# MAGNETRON SPECIFICATION

## TEST EQUIPMENT

### A. Waveguide configuration

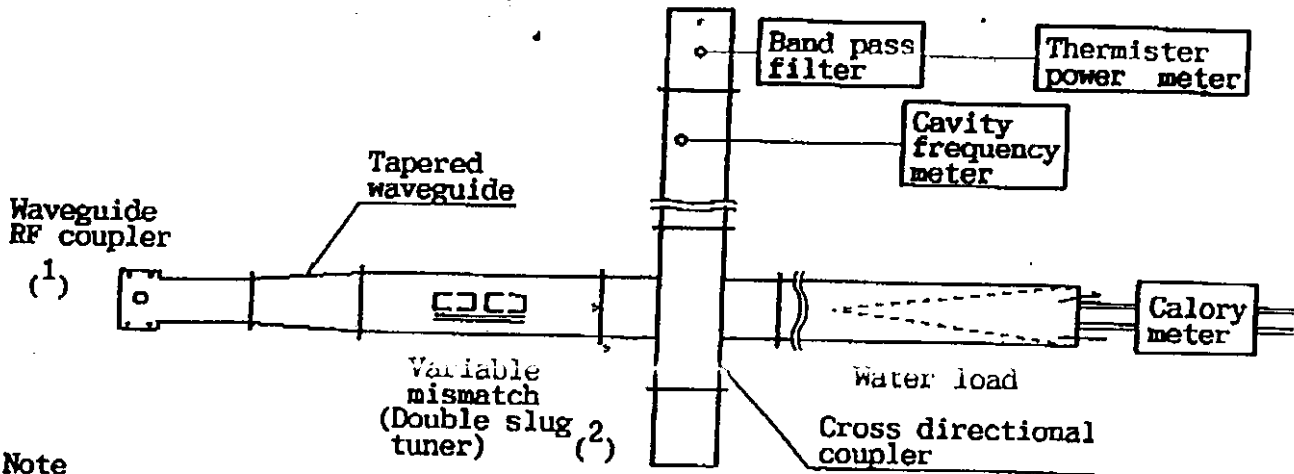

Note

- (1) Details are shown in the attached drawing (page-5).
- (2) Calibrated with the standard standing wave detector.
- (3) WR430 waveguides are used from the double slug tuner to the water load.

### B. Power supply connection

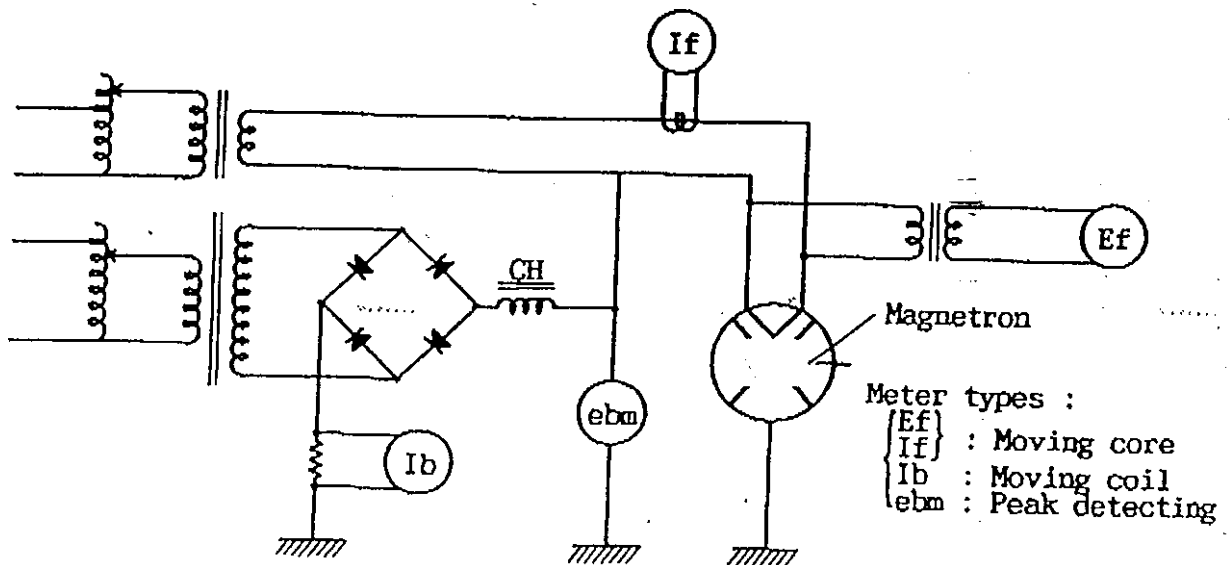

Note

- (1) Choke coil is adjusted such that the peak anode current value becomes three times the average value.

# MAGNETRON SPECIFICATION

## FILAMENT CONNECTION

To minimize possible transient voltages, the terminals (F) and (FA) should be connected to the transformer in such a way that the anode voltage increases and anode current decreases compared with those for reversed connection when a single phase half wave doubler without filter is used as a power supply.

## OUTPUT COUPLER (The output coupler used in Toshiba Hokuto inspection)

Unit : mm

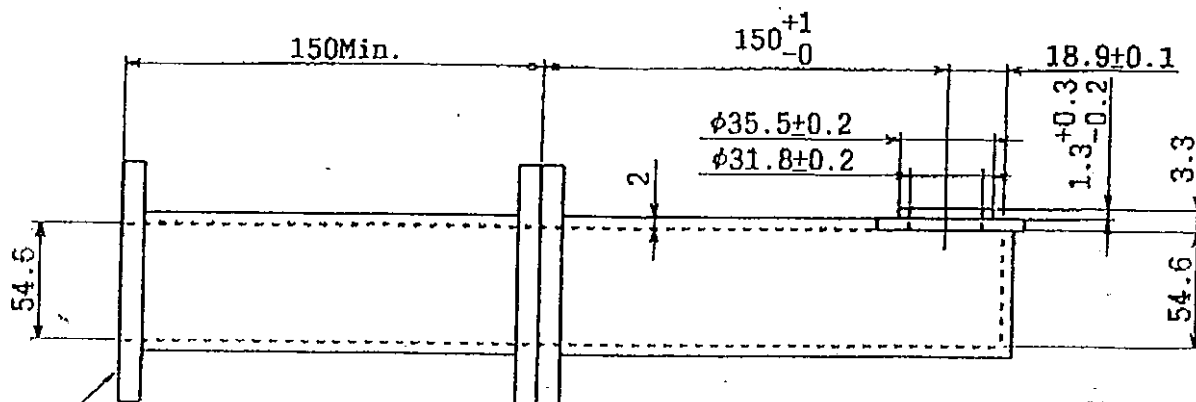
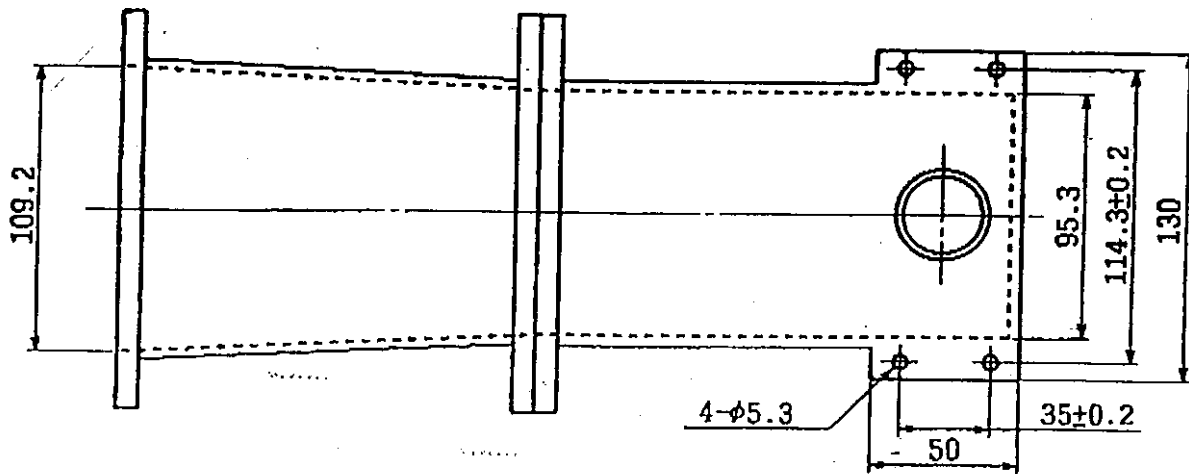

Fit to UG-435A/u or UG-437A/u(BRJ-2)

# MAGNETRON SPECIFICATION

**MAXIMUM ALLOWABLE BUILD-UP CURVE OF SEAL TEMPERATURE**

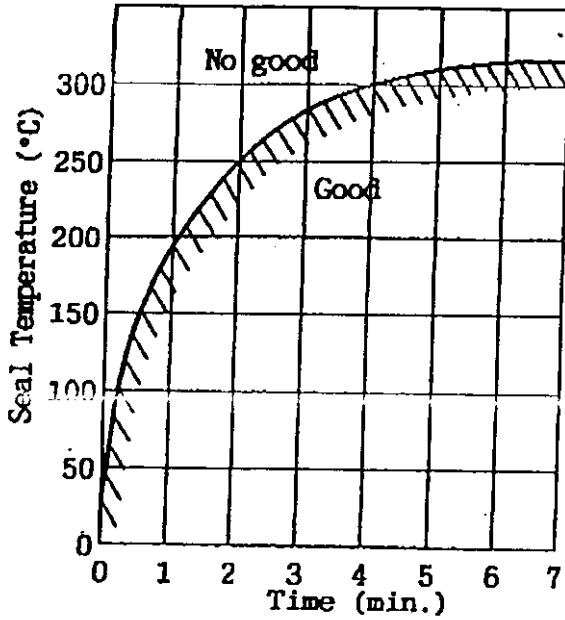

**INSULATION**

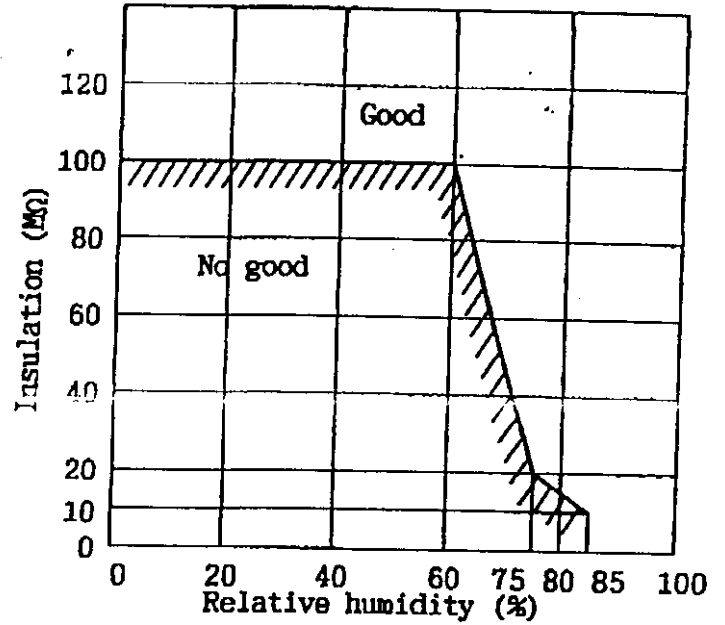

**CORRECTION FACTOR OF PEAK ANODE VOLTAGE (ebm) AND OUTPUT POWER (Po) VS. AMBIENT TEMPERATURE**

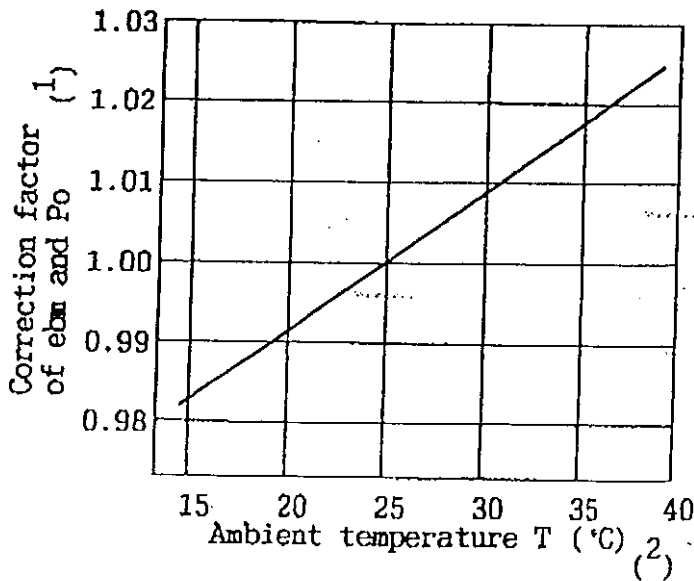

Note

$$(1) \quad \left( \begin{array}{c} \text{ebm (or } P_o) \\ \text{measured} \\ \text{at } T \text{ } ^\circ\text{C} \end{array} \right) \times \left( \begin{array}{c} \text{Correction} \\ \text{factor} \\ \text{at } T \text{ } ^\circ\text{C} \end{array} \right) = \left( \begin{array}{c} \text{ebm or } P_o \\ \text{at } 25 \text{ } ^\circ\text{C} \end{array} \right)$$

(2) The temperature shown in this figure is the constant room temperature in which the magnetron has been kept for more than 4 hours before testing.

# MAGNETRON SPECIFICATION

## OUTLINE DRAWING

Unit : mm

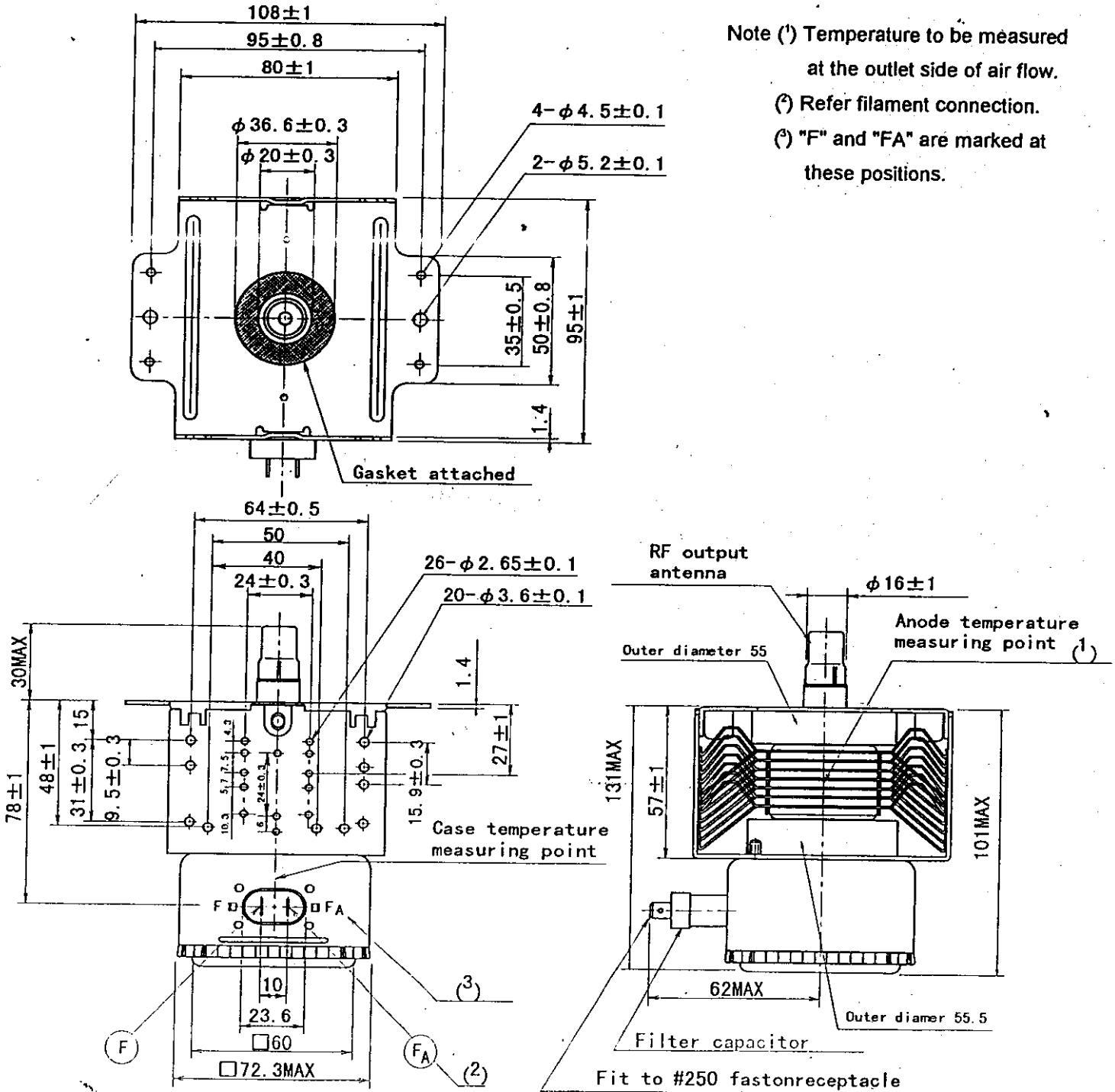

- Note (1) Temperature to be measured at the outlet side of air flow.  
 (2) Refer filament connection.  
 (3) "F" and "FA" are marked at these positions.

# MAGNETRON SPECIFICATION

## LABEL

The label as shown below shall be put on each tube.

The code stamped on the indicated position of each label consists of three block numbers; The first block is the serial number of tube with data. The second block is the date code in which the preceding one numeral shows the last of Christian Era and the continuing block letter and two numerals indicate the three months after the scheduled date of shipment from Japan. The third block is the numerals only for the production control in Toshiba Hokuto.

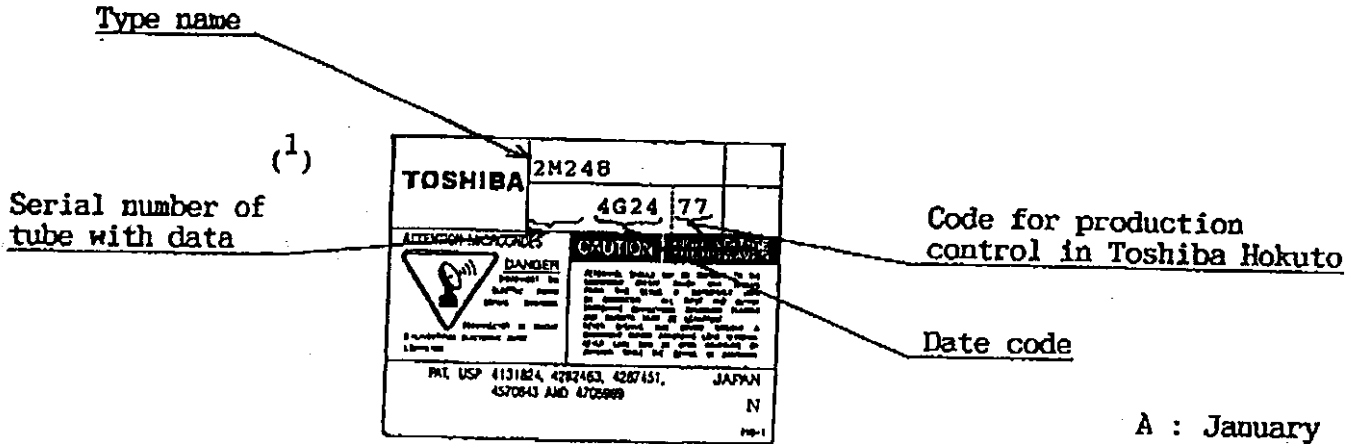

- A : January
- B : February
- C : March
- D : April
- E : May
- F : June
- G : July
- H : August
- J : September
- K : October
- L : November
- M : December

Note

<sup>(1)</sup> In case of a sample requirement only

### Sample

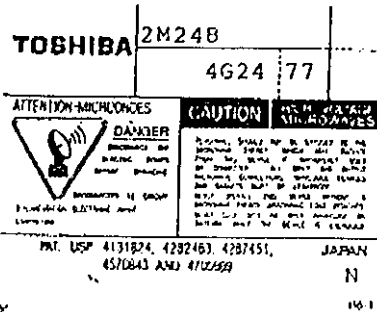

### Labeling

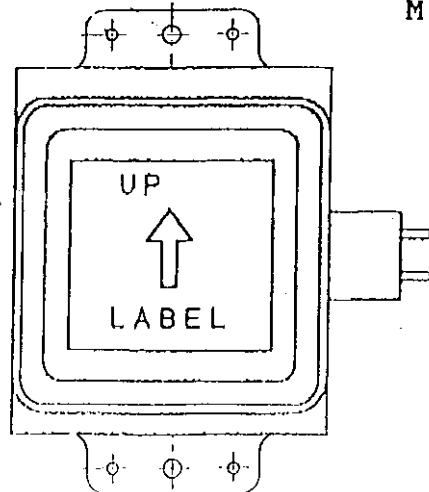

# MAGNETRON SPECIFICATION

Catalog number: HFC-2L-1,

Unit : mm

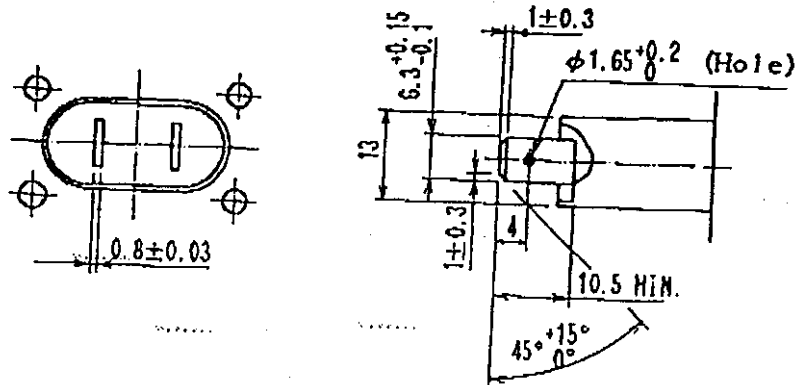
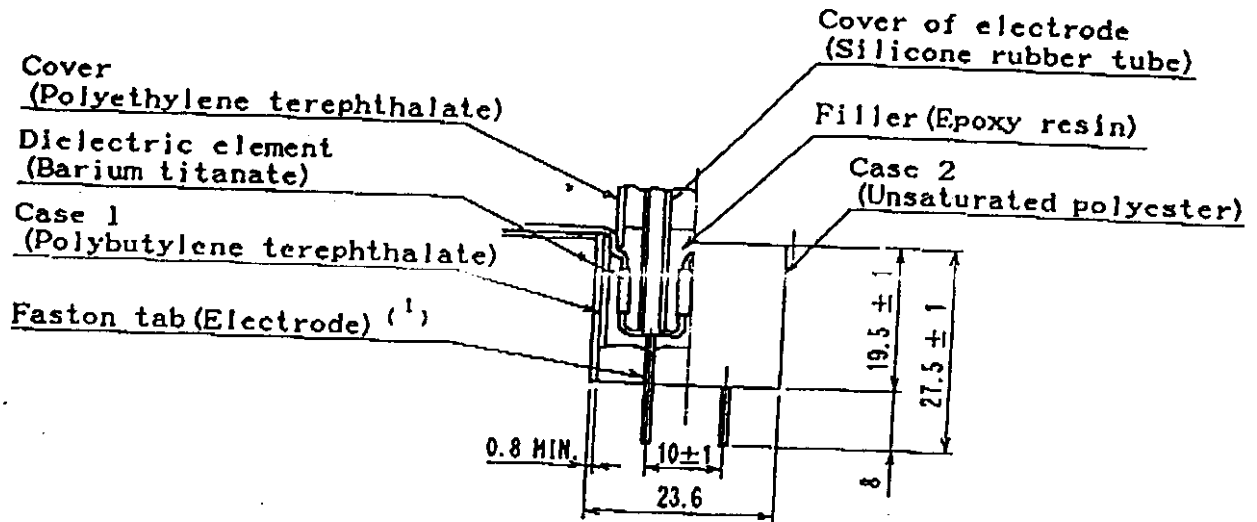

Note <sup>(1)</sup> The faston tab meets to BS 5057:1973 and DIN 46 244:April 1980

# MAGNETRON SPECIFICATION

Unit: mm

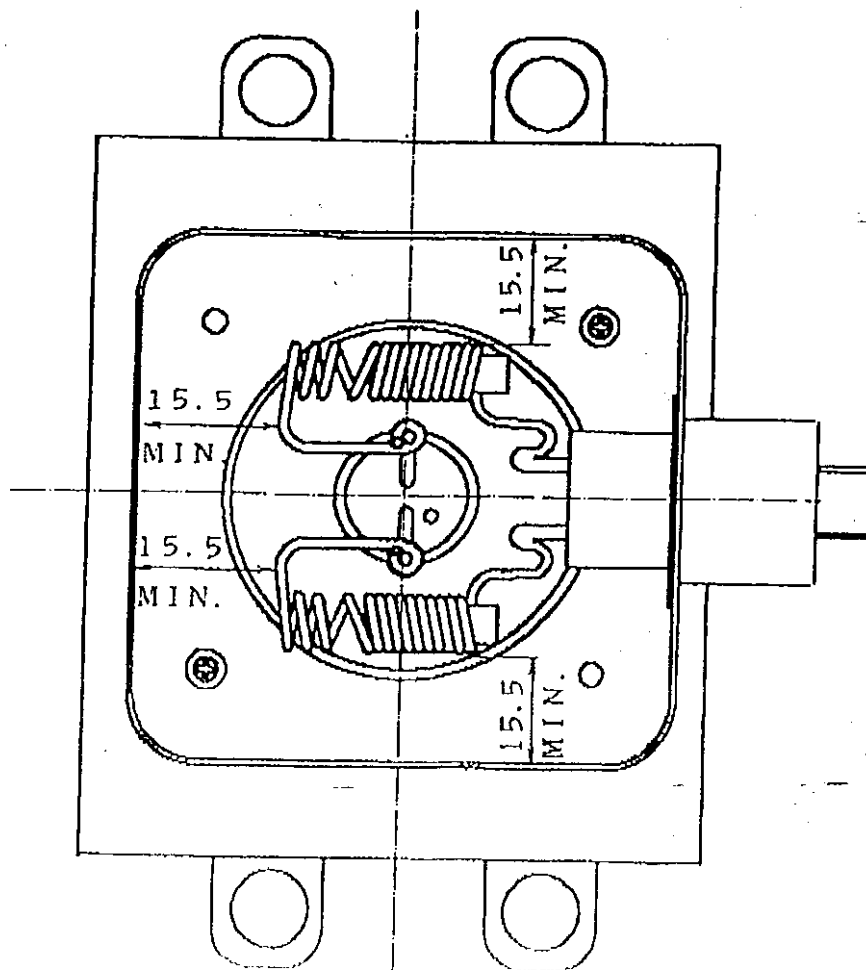
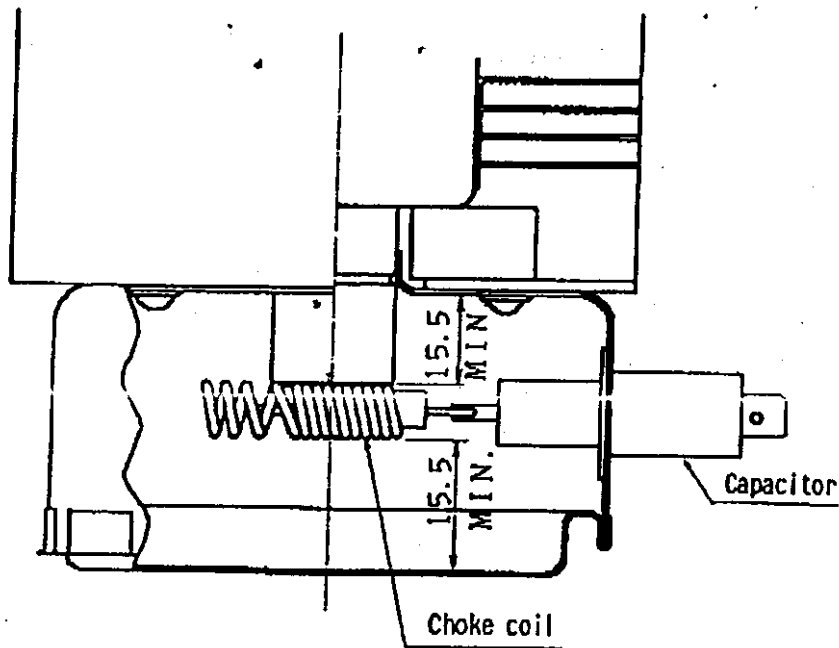

# MAGNETRON SPECIFICATION

## INSULATING MATERIAL (Refer Page-8 & 9)

Part Name	Catalog No./ Manufacturer ( <sup>2</sup> )	Material	Manufacturer of Materials	UL No. ( <sup>1</sup> )		
				Guide No.	File No.	Grade No.
Capacitor	Toshiba Hokuto Spec. HFC-2L-1/ TDK Corp.	Barium Titanate	TDK Corp.	-	-	-
		Epoxy Resin	Ditto	-	-	-
		Silicone Rubber Tube	Shin-etsu Chemical Co., Ltd.	-	-	-
		Polyethylene terephthalate	Teijin Ltd.	QMF-Z2	E52857M	CN9015
		Polybutylene terephthalate	Poly Plastics Co., Ltd.	QMF-Z2	E45034M	2082
		Unsaturated polyester	Matsushita Electric Works Ltd.	QMF-Z2	E41404S	CE5100
choke coil	Toshiba Hokuto Spec. / Kokusan Bane Co., Ltd. or Hirose Spring Factory Corporation	Ferrite	Tomita Electric Co., Ltd. HITACHI Ferrite Co., Ltd. or Fuji Denki Kagaku Co., Ltd.	-	-	-
		Formal Coated Wire	Daiichi Denko Co., Ltd. or Showa Electric Wire & Cable Co., Ltd.	-	-	-
		Silicone Rubber	Toshiba Silicone Co., Ltd.	-	-	-

- Note
- (<sup>1</sup>) UL No. is for the material.
  - (<sup>2</sup>) One of them shall be used by Toshiba Hokuto's option.



# MAGNETRON SPECIFICATION

## FILTER CIRCUIT

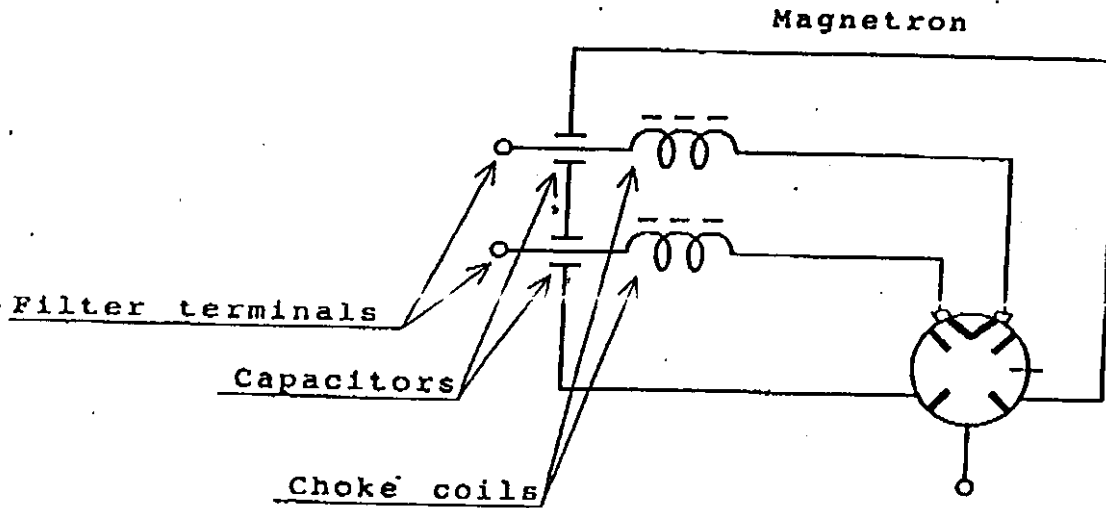

## RATING

	Nominal Value	Remarks
Capacitor	500 pF × 2 WV 10kVdc	—
Choke Coil (13.5 turns)	1.2 μH × 2	at about 8 MHz

# MAGNETRON SPECIFICATION

ri

## GASKET

Unit: mm

Toshiba part No. : 3331-816C

Material : Woven and press formed brass wire

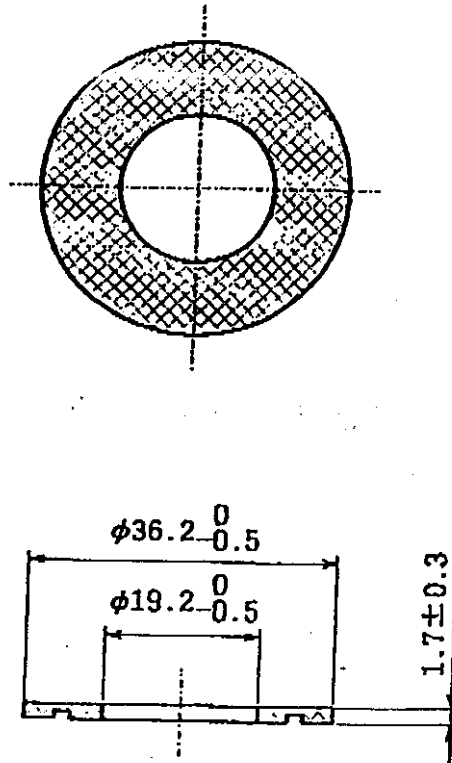

Inspection : By using thick part of slide calipers

# MAGNETRON SPECIFICATION

## PRECAUTIONS FOR SAFETY

Carefully take the following precautions for safety in using the magnetrons for microwave ovens or for other applications. Magnetrons must be handled by individuals possessing adequate backgrounds of electrical, electronic, microwave and mechanical experience. Toshiba Hokuto Electronics Corporation cannot be responsible for the interpretation of this information, nor can it be assumed any liability in connection with its use.

### 1. High Voltage

Since the magnetron is operated with negative high potential at the cathode terminals, a special care must be taken as follows.

- 1-1 Do not touch nor come close to the cathode terminals or their surroundings during operation.
- 1-2 To avoid shock hazards, never insert metallic wire or like into the filter box, and never operate the magnetron with the lid of filter box open.
- 1-3 Before removing the magnetron from the oven, carefully check that power is turned off, and discharge the cathode terminal or the capacitors in the power supply circuit by using the discharging rod adequately designed for safety.

### 2. Radiation Leakage

Care should be taken for radiation leaked from the magnetron, though the leakage from the input part of magnetron is restricted to a level which human body is not adversely affected.

- 2-1 Properly install and tightly fasten the magnetron in the oven or in the waveguide coupler.
- 2-2 Do not deform the gasket or do not operate the magnetron with the gasket removed, to avoid hazardous conditions such as radiation leakage and arcing.
- 2-3 Never operate the magnetron without installing it in the oven or with the output antenna exposed.
- 2-4 Do not remove the lid of the filter box nor deform the filter box.
- 2-5 Always keep your eyes apart from the operating magnetron in consideration of the unexpected hazardous conditions.

### 3. Temperature

Although the magnetron is subjected to forced air cooling during operation, high temperature (sometimes more than 200°C) is observed on the enclosure of magnetron. Care should be taken as follows.

- 3-1 Do not touch the magnetron immediately after turning power off. Allow the magnetron to cool before handling.
- 3-2 Putting on cotton gloves or the equivalents is recommended for safe handling.

# MAGNETRON SPECIFICATION

## RECORD OF REVISION

A) Original Specification: E06007-D01

April 14, 1994

STATUS & DATE	PAGE	REVISION	NOTES