

5. Specification of TOSHIBA Magnetron of 2M248

▶ FCC ID : C5F7NF16MO1100 ◀

TOSHIBA

TOSHIBA HOKUTO ELECTRONICS CORPORATION
MAGNETRON ENGINEERING DEPARTMENT
1975, 23-CHOME, MINAMI 8-JODORI, ASAHIKAWA, HOKKAIDO 078, JAPAN
PHONE: (0166) 31-4728 FACSIMILE: (0166) 35-5671

To: DAEWOO ELECTRONICS CO., LTD.

APPROVAL SIGNATURE

SPECIFICATION

FOR
MAGNETRON
2M248



Hisao Saito
SENIOR MANAGER,
MAGNETRON ENGINEERING DEPARTMENT

SPECIFICATION NUMBER : E06007-D01 April 14, 1994
REVISION STATUS :

MAGNETRON SPECIFICATION

This specification is based on the testing methods for continuous wave magnetrons ED-1501 set by the Electronic Industries Association of Japan (EIAJ).

Continuous Wave Magnetron												
DESCRIPTION	Magnetron (Fixed Frequency, Integral Magnet, Forced Air Cooled)											
FUNCTION	2450 MHz band continuous wave oscillation											
OUTER DIMENSIONS	See outline drawing											
ABSOLUTE MAXIMUM RATINGS	Term	Ef	tk	ebm	lb	ibm	Pi	σ_L	Tp	Tcase	Tstorage	Tseal
	Unit	V	s	kV	mAdc	A	kW	-	°C	°C	°C	°C
	Max	3.60	-	4.85	380	1.5	1.7	4	300	100	60	320
	Min	2.70	0	-	-	-	-	-	-	-	-30	-
STANDARD TEST CONDITION: (°)	3.15	5	-	330	-	-	1.1Max	-	-	-	-	-
TEST SPECIFICATIONS												
TEST TERM (°)	TEST METHOD (EIAJ ED-1501)	TEST CONDITION	SYMBOL	BOGIE	LIMIT		UNIT					
					Min	Max						
** Vibration	5.4.1		-	-	-	-	-					
Breakdown Voltage	4.2	Et=10kVdc or 8kVac (rms)(¹¹)	-	-	-	-	-					
Insulation	-	Et=1kVdc (⁷)	-	-	-	-	-					
* Cold Start Voltage Transient	-	(°)	-	-	-	8.5	kV					
* Filament Current	4.1.1	tk=120s	If	10.0	8.0	12.0	A					
Peak Anode Voltage	4.3.1	(°)	ebm	4.35	4.15	4.55	kV					
Average Output Power (1)	4.3.3.1	(°)	Po	1020	970	1070	W					
* Average Output Power (2)	4.3.3.2	$\sigma_L=4$, Power Min (°)	Po	-	540	-	W					
Frequency	4.3.4	(°)	f	2460	2450	2470	MHz					
* Stability/Moding (1)	4.3.11.2	$\sigma_L=2,3,4$	-	-	-	-	-					
Stability/Moding (2)	4.3.11.2	$\sigma_L=3$, ibm=0.85A t=15s	-	-	-	-	-					
* Stability/Runaway	4.3.11.1	$\sigma_L=6$, t=30s	-	-	-	-	-					
* Pulling Factor	4.3.6	$\sigma_L=2$	fpl	-	-	21	MHz					
* Sink Phase	4.3.7	$\sigma_L=2$	$\lambda_{sink} / \lambda_g$	0.235	-	-	-					
** Life Test	4.5.1		t	-	500	-	h					
** Life Test End Point	Average Output Power (1)	4.3.3.1	(°)	Po	-	770	-	W				
	Stability/ Moding	4.3.11.2	$\sigma_L=2,3,4$	-	-	-	-					
	Stability/ Runaway	4.3.11.1	$\sigma_L=6$, t=30s	-	-	-	-					

MAGNETRON SPECIFICATION

Note

- (1) The tube shall be mounted on the output coupler (containing tapered waveguide) shown in the attached drawing (Page-5) and cooled by forced air of 800 ϕ /min. Single phase full wave rectifier without filter shall be used for power supply. The diagram of the test equipment is shown in the attached drawing (Page-4).
- (2) During normal oscillation.
- (3) The point for measuring anode temperature is shown in the outline drawing. Maximum anode temperature for normal condition (with load in the cavity) should be 250°C.
- (4) The point for measuring filter case temperature is shown in the outline drawing.
- (5) Tseal means temperature of ceramic-to-metal seal position of the tube. Maximum allowable build-up curve of seal temperature is shown in the attached drawing (Page-6).
- (6) Tests shall be classified as follows:

Class	Mark [†]	Remarks
Production test	None	This test is intended to ensure if the production line is being processed in compliance with the standard, and shall be conducted on some typical characteristics which are considered to be affected by changes in the process.
Design test	*	This test is intended to ensure the standard design, and shall be conducted on such characteristics which are not affected by the ordinary production line as long as the design is maintained.
Type approval test	**	This test is intended to ensure the compliance of the standard design with given specifications, and may be omitted unless a substantial change in the design is made.

† : The mark is placed on the left of each test item, for instance,

* Insulation.

- (7) See the attached drawing (Page-6, Insulation).
- (8) Measurement shall be conducted by standard oven which has a single phase half wave doubler power supply without filter, where no load voltage of the transformer shall be less than 2.2 kV rms. The voltage transient just before start of oscillation shall be measured.
- (9) Measurement shall be conducted within 15 seconds after anode power is turned on. Magnetron is kept in the constant ambient temperature for more than 4 hours before testing. Standard ambient temperature is 25°C. Correction factor of peak anode voltage (ebm) and output power (Po) vs. temperature is shown in the attached drawing (Page-6).
- (10) For each oven model, both microwave oven manufacturer and Toshiba Hokuto should evaluate and agree on the stability characteristics in the design stage of the oven.

MAGNETRON SPECIFICATION

TEST EQUIPMENT

A. Waveguide configuration

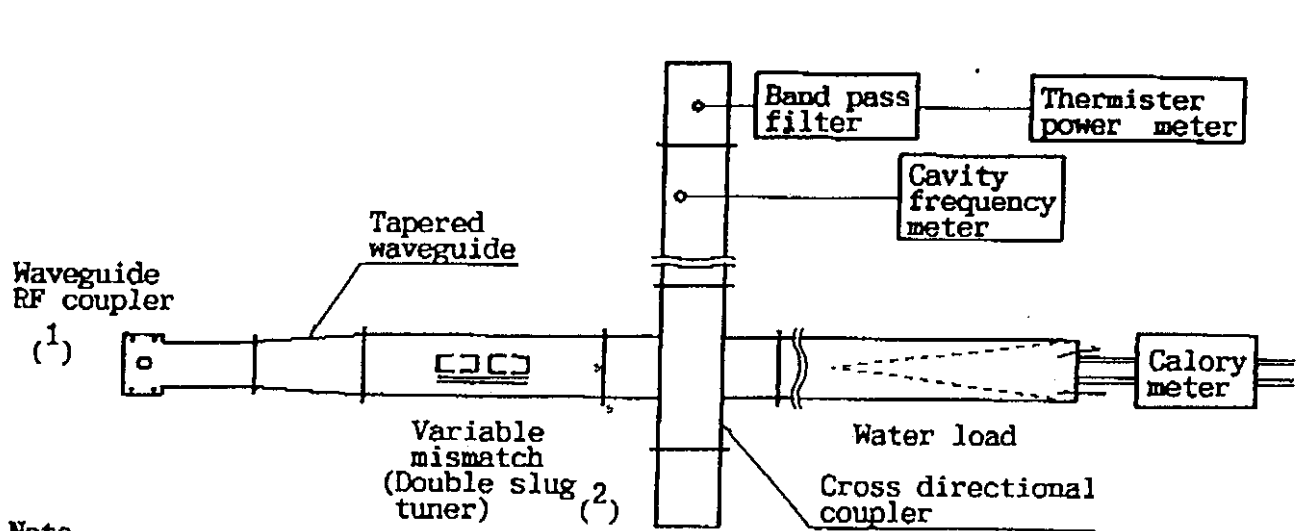

Note

- (1) Details are shown in the attached drawing (page-5).
- (2) Calibrated with the standard standing wave detector.
- (3) WR430 waveguides are used from the double slug tuner to the water load.

B. Power supply connection

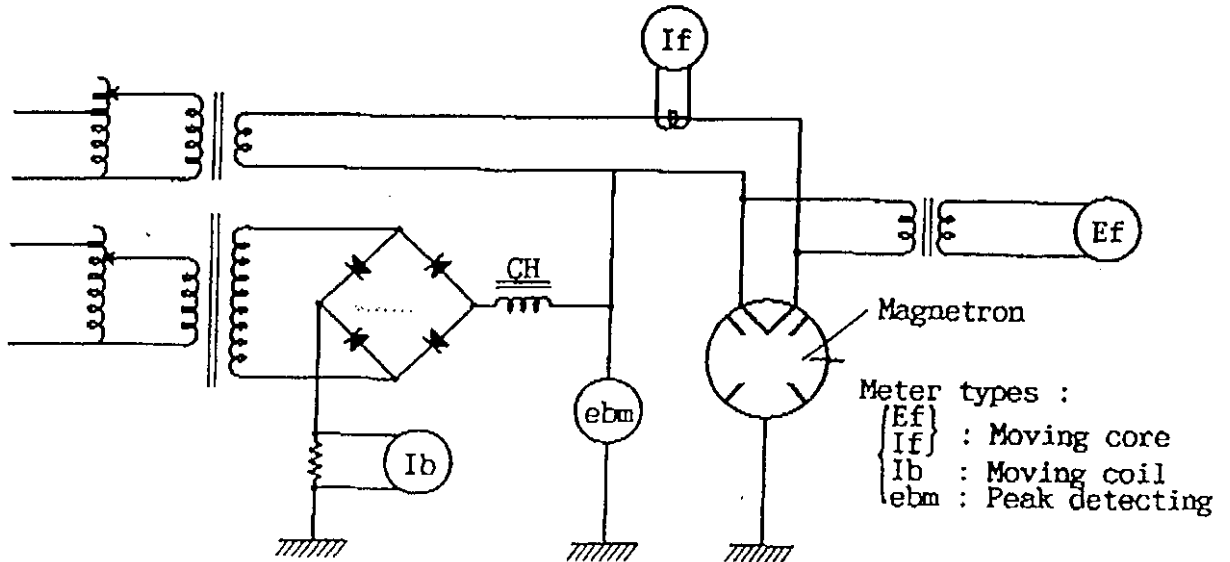

Note

- (1) Choke coil is adjusted such that the peak anode current value becomes three times the average value.

MAGNETRON SPECIFICATION

FILAMENT CONNECTION

To minimize possible transient voltages, the terminals (F) and (FA) should be connected to the transformer in such a way that the anode voltage increases and anode current decreases compared with those for reversed connection when a single phase half wave doubler without filter is used as a power supply.

OUTPUT COUPLER (The output coupler used in Toshiba Hokuto inspection)

Unit : mm

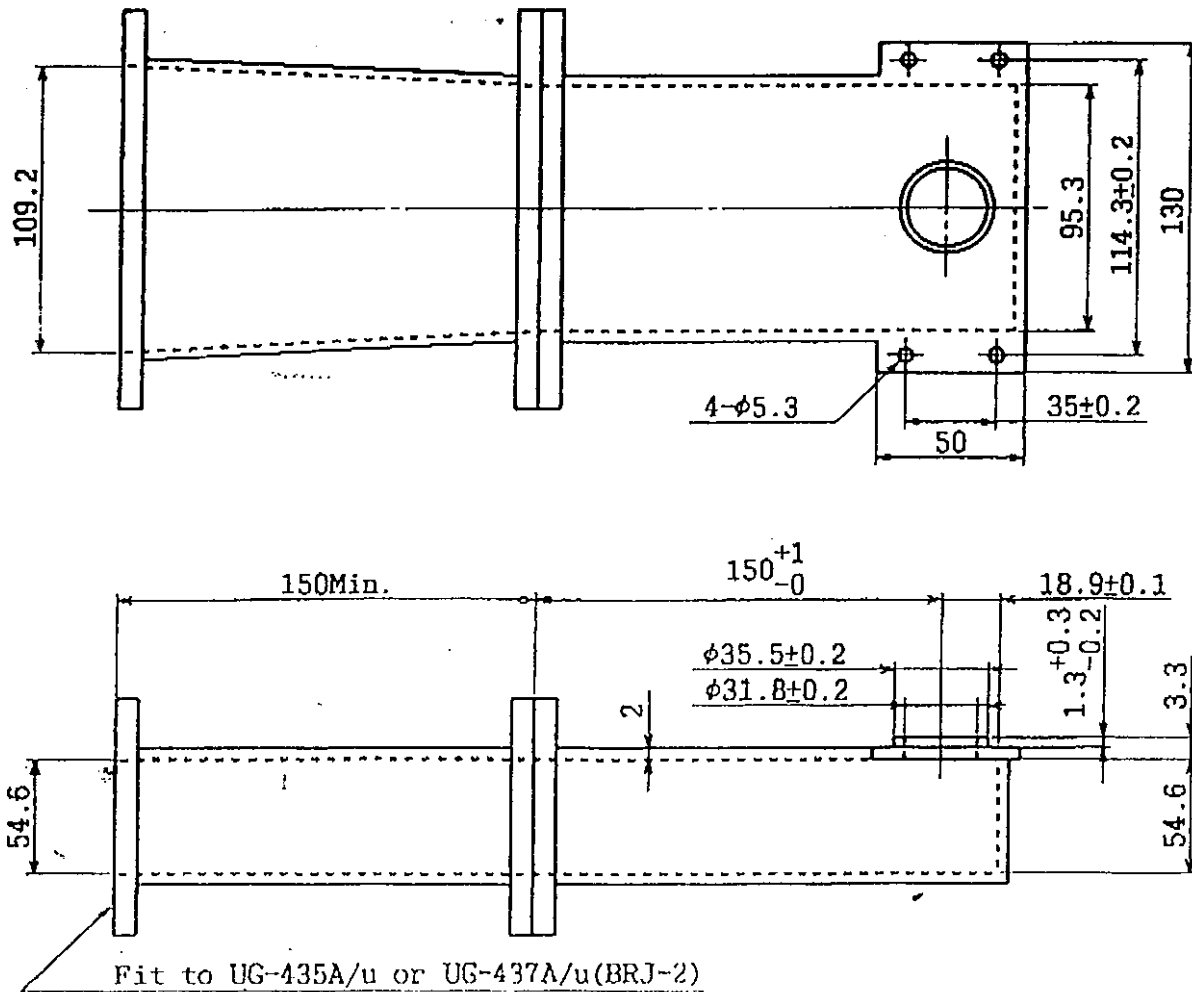

MAGNETRON SPECIFICATION

MAXIMUM ALLOWABLE BUILD-UP CURVE OF SEAL TEMPERATURE

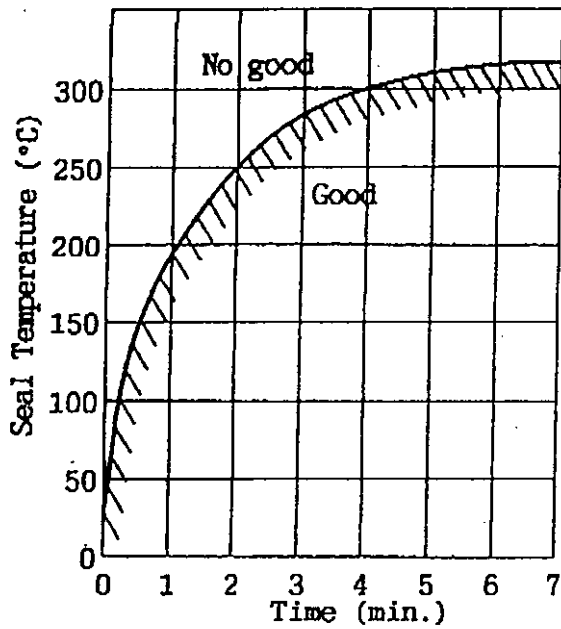

INSULATION

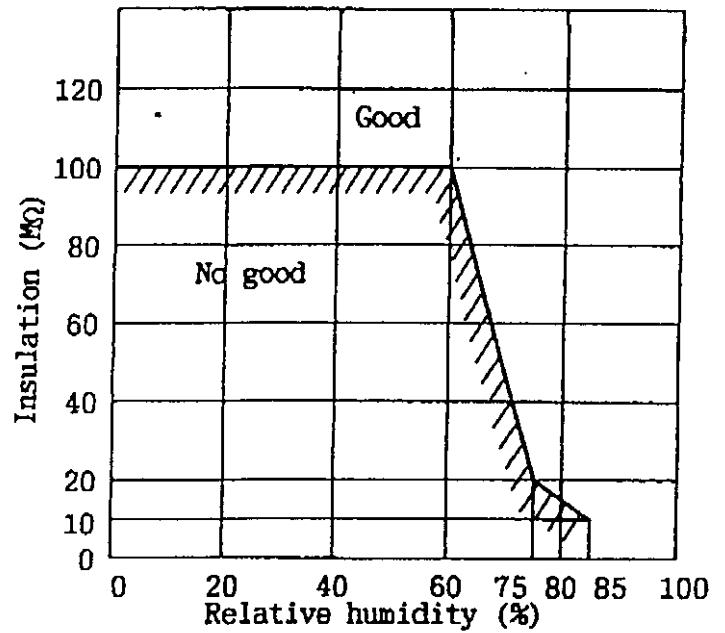

CORRECTION FACTOR OF PEAK ANODE VOLTAGE (ebm) AND OUTPUT POWER (Po) VS. AMBIENT TEMPERATURE

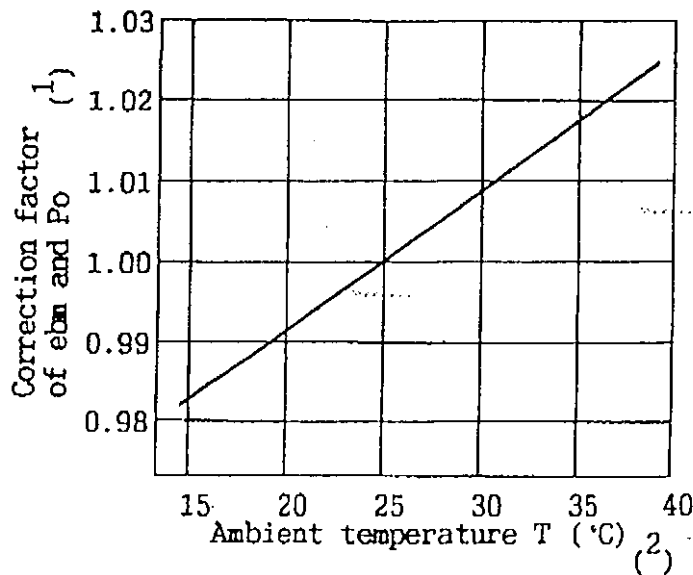

Note

$$(1) \quad \left(\begin{array}{c} \text{ebm (or Po)} \\ \text{measured} \\ \text{at } T \text{ } ^\circ\text{C} \end{array} \right) \times \left(\begin{array}{c} \text{Correction} \\ \text{factor} \\ \text{at } T \text{ } ^\circ\text{C} \end{array} \right) = \left(\begin{array}{c} \text{ebm or Po} \\ \text{at } 25 \text{ } ^\circ\text{C} \end{array} \right)$$

(2) The temperature shown in this figure is the constant room temperature in which the magnetron has been kept for more than 4 hours before testing.

MAGNETRON SPECIFICATION

OUTLINE DRAWING

Unit : mm

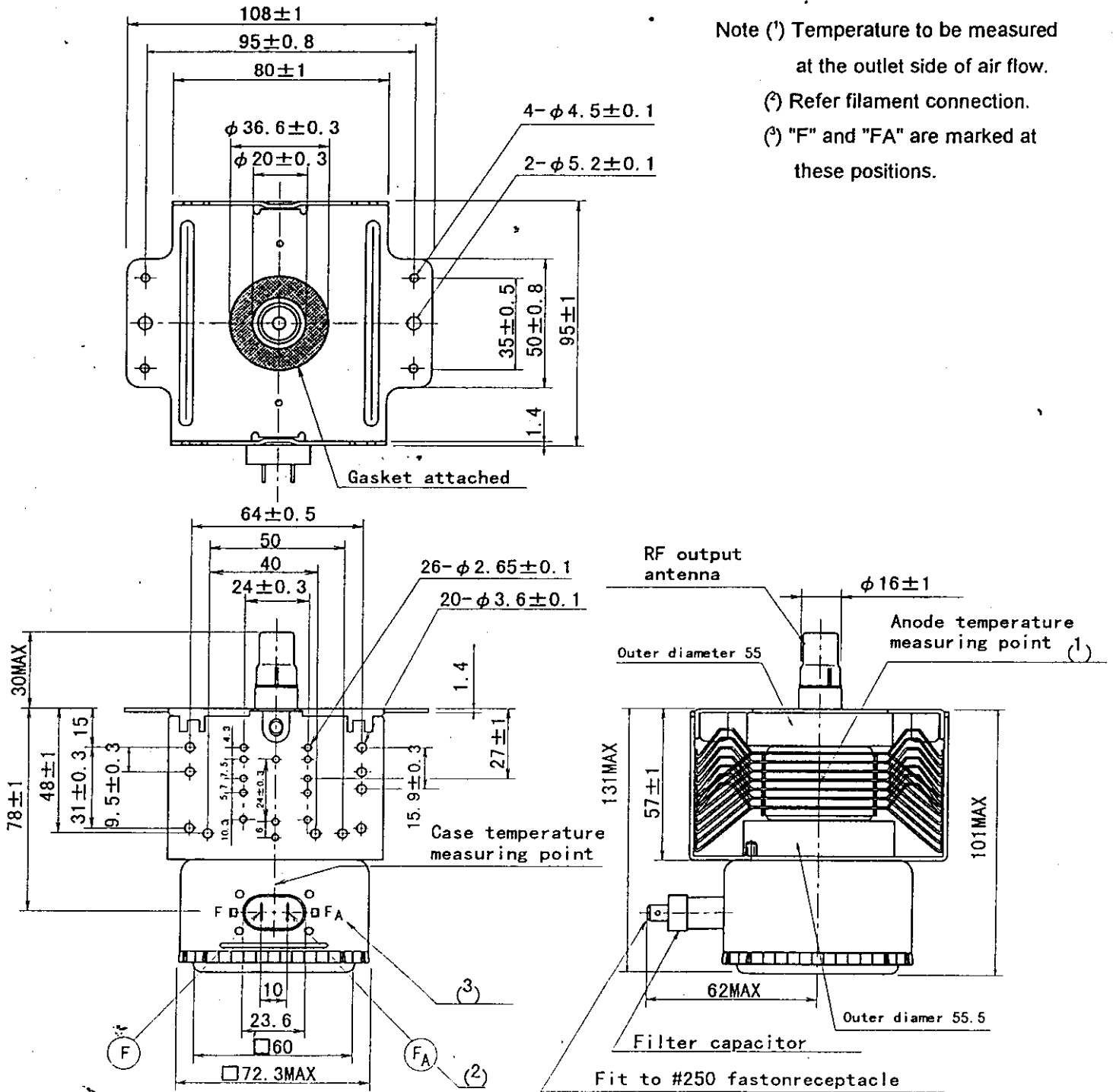

- Note (1) Temperature to be measured at the outlet side of air flow.
- (2) Refer filament connection.
- (3) "F" and "FA" are marked at these positions.

MAGNETRON SPECIFICATION

LABEL

The label as shown below shall be put on each tube.

The code stamped on the indicated position of each label consists of three block numbers; The first block is the serial number of tube with data. The second block is the date code in which the preceding one numeral shows the last of Christian Era and the continuing block letter and two numerals indicate the three months after the scheduled date of shipment from Japan. The third block is the numerals only for the production control in Toshiba Hokuto.

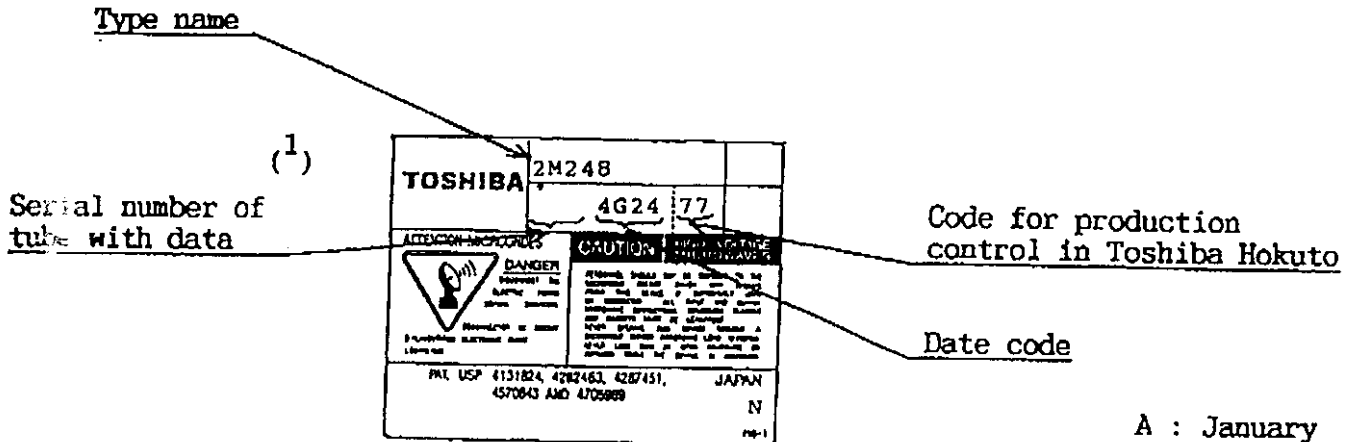

Note

(1) In case of a sample requirement only

- A : January
- B : February
- C : March
- D : April
- E : May
- F : June
- G : July
- H : August
- J : September
- K : October
- L : November
- M : December

Sample

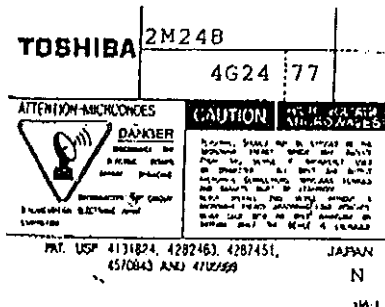

Labeling

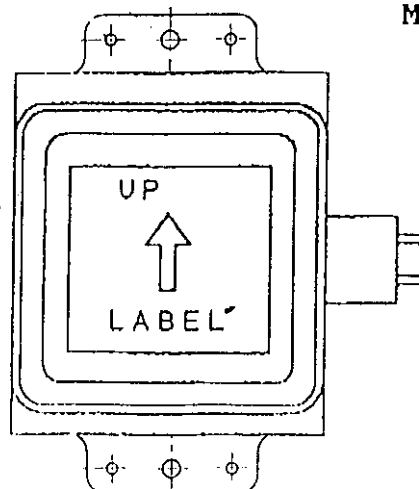

MAGNETRON SPECIFICATION

Catalog number : HFC-2L-1

Unit : mm

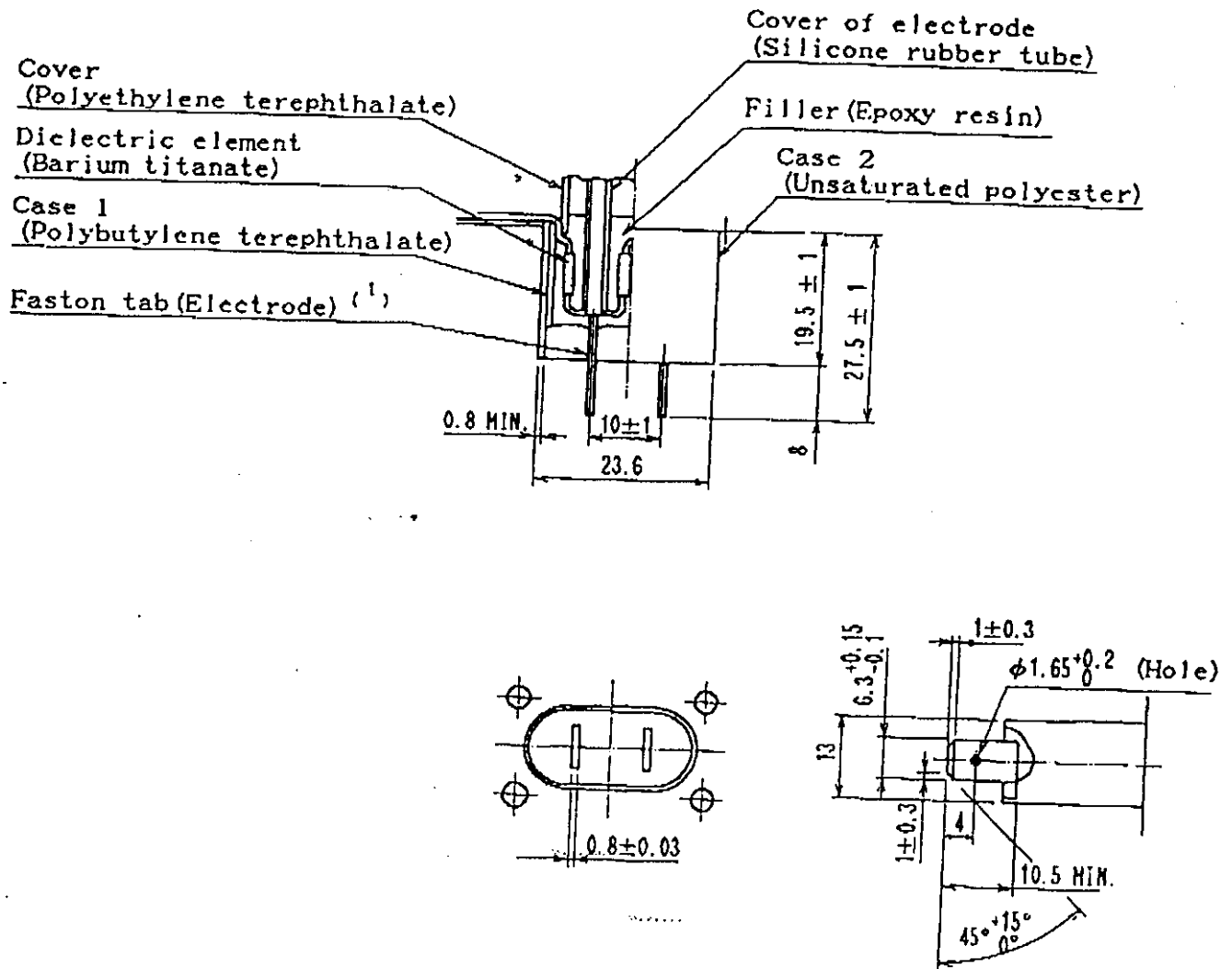

Note ⁽¹⁾ The faston tab meets to BS 5057:1973 and DIN 46 244:April 1980

MAGNETRON SPECIFICATION

Unit: mm

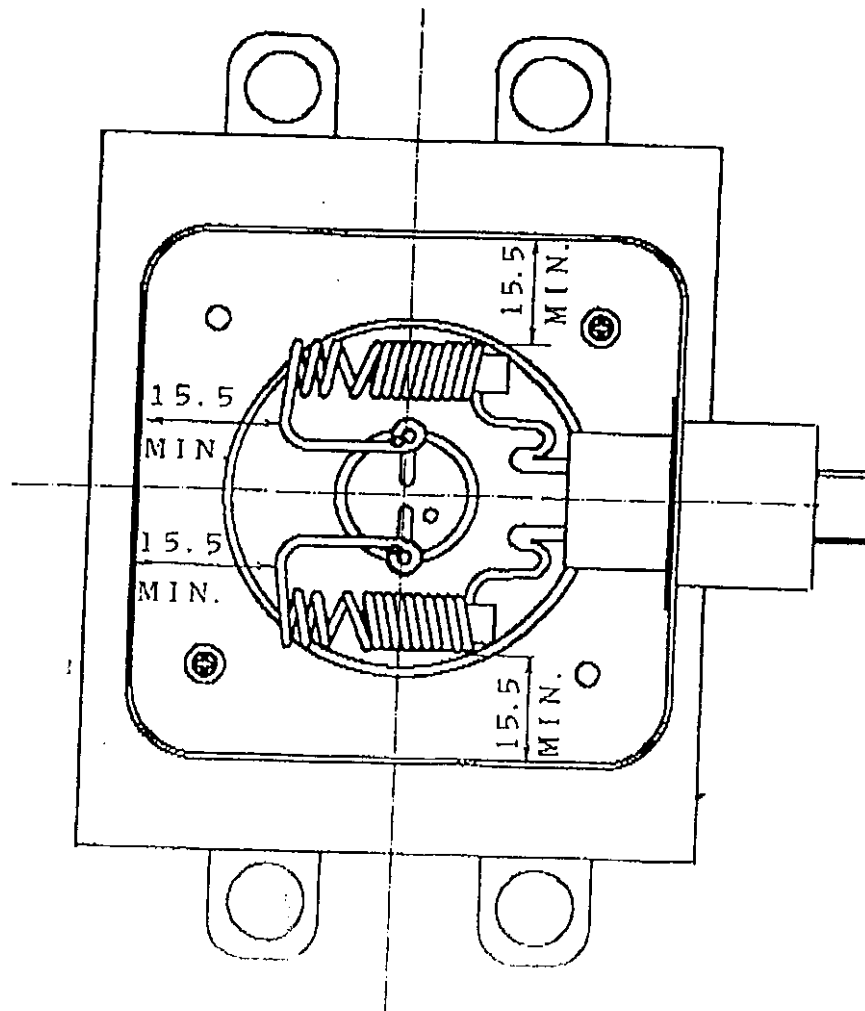
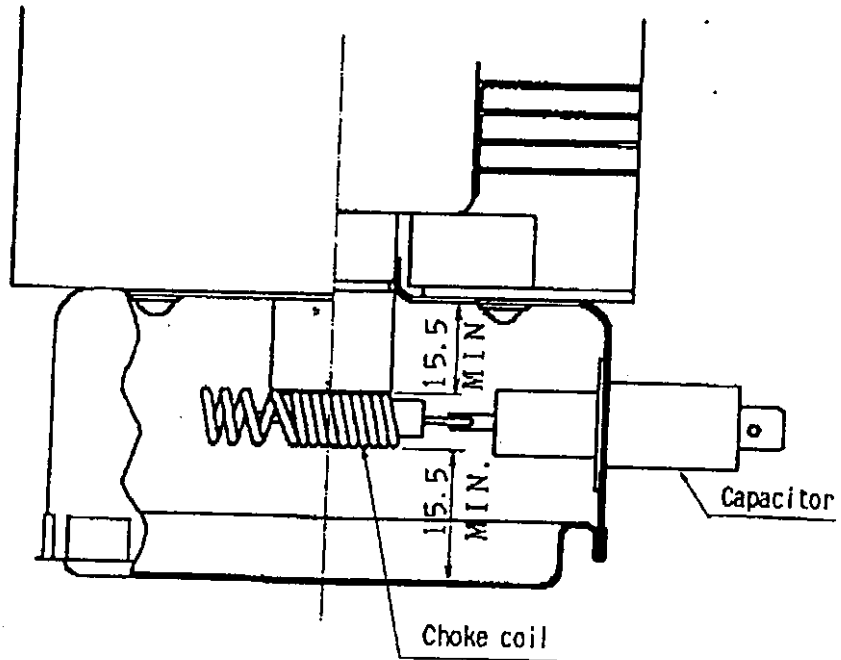

MAGNETRON SPECIFICATION

INSULATING MATERIAL (Refer Page-8 & 9)

Part Name	Catalog No./ Manufacturer (²)	Material	Manufacturer of Materials	UL No. (¹)		
				Guide No.	File No.	Grade No.
Capacitor	Toshiba Hokuto Spec. HFC-2L-1/ TDK Corp.	Barium Titanate	TDK Corp.	-	-	-
		Epoxy Resin	, Ditto	-	-	-
		Silicone Rubber Tube	Shin-etsu Chemical Co.,Ltd.	-	-	-
		Polyethylene terephthalate	Teijin Ltd.	QMF-Z2	E52857M	CN9015
		Polybutylene terephthalate	Poly Plastics Co.,Ltd.	QMF-Z2	E45034M	2082
		Unsaturated polyester	Matsushita Electric Works Ltd.	QMF-Z2	E41404S	CE5100
choke coil	Toshiba Hokuto Spec. / Kokusen Bane Co.,Ltd. or Hirose Spring Factory Corporation	Ferrite	Tomita Electric Co.,Ltd. HITACHI Ferrite Co.,Ltd. or Fuji Denki Kagaku Co.,Ltd.	-	-	-
		Formal Coated Wire	Daiichi Denko Co.,Ltd. or Showa Electric Wire & Cable Co.,Ltd.	-	-	-
		Silicone Rubber	Toshiba Silicone Co.,Ltd.	-	-	-

Note

(¹) UL No. is for the material.

(²) One of them shall be used by Toshiba Hokuto's option.

MAGNETRON SPECIFICATION

FILTER CIRCUIT

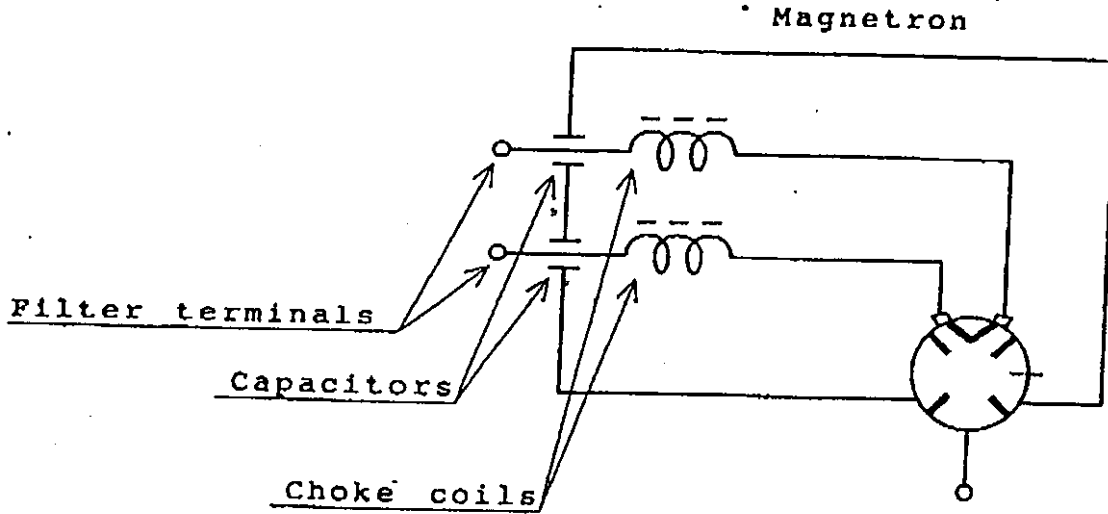

RATING

	Nominal Value	Remarks
Capacitor	500 pF × 2 WV 10kVdc	—
Choke Coil (13.5 turns)	1.2 μH × 2	at about 8 MHz

MAGNETRON SPECIFICATION

ori

GASKET

Unit: mm

Toshiba part No. : 3331-816C

Material : Woven and press formed brass wire

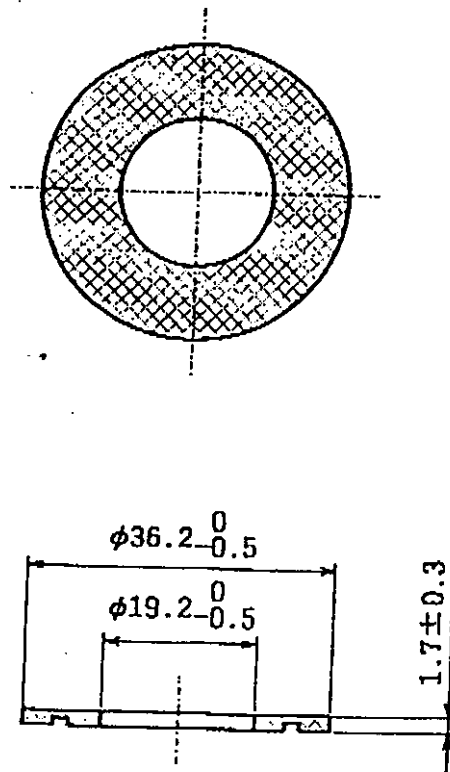

Inspection : By using thick part of slide calipers

MAGNETRON SPECIFICATION

PRECAUTIONS FOR SAFETY

Carefully take the following precautions for safety in using the magnetrons for microwave ovens or for other applications. Magnetrons must be handled by individuals possessing adequate backgrounds of electrical, electronic, microwave and mechanical experience. Toshiba Hokuto Electronics Corporation cannot be responsible for the interpretation of this information, nor can it be assumed any liability in connection with its use.

1. High Voltage

Since the magnetron is operated with negative high potential at the cathode terminals, a special care must be taken as follows.

- 1-1 Do not touch nor come close to the cathode terminals or their surroundings during operation.
- 1-2 To avoid shock hazards, never insert metallic wire or like into the filter box, and never operate the magnetron with the lid of filter box open.
- 1-3 Before removing the magnetron from the oven, carefully check that power is turned off, and discharge the cathode terminal or the capacitors in the power supply circuit by using the discharging rod adequately designed for safety.

2. Radiation Leakage

Care should be taken for radiation leaked from the magnetron, though the leakage from the input part of magnetron is restricted to a level which human body is not adversely affected.

- 2-1 Properly install and tightly fasten the magnetron in the oven or in the waveguide coupler.
- 2-2 Do not deform the gasket or do not operate the magnetron with the gasket removed, to avoid hazardous conditions such as radiation leakage and arcing.
- 2-3 Never operate the magnetron without installing it in the oven or with the output antenna exposed.
- 2-4 Do not remove the lid of the filter box nor deform the filter box.
- 2-5 Always keep your eyes apart from the operating magnetron in consideration of the unexpected hazardous conditions.

3. Temperature

Although the magnetron is subjected to forced air cooling during operation, high temperature (sometimes more than 200°C) is observed on the enclosure of magnetron. Care should be taken as follows.

- 3-1 Do not touch the magnetron immediately after turning power off. Allow the magnetron to cool before handling.
- 3-2 Putting on cotton gloves or the equivalents is recommended for safe handling.

MAGNETRON SPECIFICATION

RECORD OF REVISION

A)

Original Specification: E06007-D01

April 14, 1994

STATUS & DATE	PAGE	REVISION	NOTES