



Zacta

TEST REPORT

Report number : Z101C-16017

Issue date : March 4, 2016

The device, as described herewith, was tested pursuant to applicable test procedure and complies with the requirements of;

FCC Part15 Subpart E IC RSS-247

The test results are traceable to the international or national standards.

Applicant	: Seiko Instruments Inc.
Equipment under test (EUT)	: Wireless LAN module
Model number	: IFWL-001
FCC ID	: C4ZAB000005
IC Certification number	: 4445A-AB000005

Date of test : January 6, 8, 12, 13, 18, 19, 20, 21, 22, 26, 28, February 10, 2016
 Test place : TÜV SÜD Zacta Ltd. Yonezawa Testing Center
 4149-7 Hachimanpara 5-chome
 Yonezawa-shi Yamagata 992-1128 Japan
 Phone: +81-238-28-2880 Fax: +81-238-28-2888
 Test results : Complied

The results in this report are applicable only to the equipment tested.
 This report shall not be re-produced except in full without the written approval of TÜV SÜD Zacta Ltd.
 This test report must not be used by the client to claim product certification, approval, or endorsement by NVLAP, NIST, or any agency of the federal government.

Tested by : Hikaru Shibata
 Hikaru Shibata

Tested by : Kazunori Saito
 Kazunori Saito

Authorized by : Hiroaki Suzuki
 Hiroaki Suzuki
 Manager of EMC Technical Department



Table of contents

	Page
1. Summary of Test	4
1.1 Purpose of test	4
1.2 Standards	4
1.3 List of applied test to the EUT	4
1.4 Modification to the EUT by laboratory	4
2. Equipment Under Test	5
2.1 General Description of equipment	5
2.2 EUT information	5
2.3 Variation of the family model(s)	6
2.4 Operating channels and frequencies	6
2.5 Operating mode	7
2.6 Operating mode	7
3. Configuration of equipment	8
3.1 Equipment(s) used	8
3.2 Cable(s) used	8
3.3 System configuration	9
4. 26dB Bandwidth and 99% Occupied Bandwidth	10
4.1 Measurement procedure	10
4.2 Limit	10
4.3 Measurement result	10
4.4 Trace data	12
5. 6dB Bandwidth	20
5.1 Measurement procedure	20
5.2 Limit	20
5.3 Measurement result	20
5.4 Trace data	21
6. Maximum Conducted Output Power	23
6.1 Measurement procedure	23
6.2 Limit	23
6.3 Measurement result	25
6.4 Trace data	26
7. Peak Power Spectral Density	34
7.1 Measurement procedure	34
7.2 Limit	34
7.3 Measurement result	35
7.4 Trace data	36
8. Radiated Emissions (Restricted Bands of Operation)	44
8.1 Measurement procedure	44
8.2 Calculation method	45
8.3 Limit	45
8.4 Test data	46
9. Frequency Stability	57
9.1 Measurement procedure	57



Zacta

9.2 Limit.....	57
9.3 Measurement result.....	58
10. AC Power Line Conducted Emissions.....	60
10.1 Measurement procedure.....	60
10.2 Calculation method.....	60
10.3 Limit.....	60
10.4 Test data.....	61
11. Duty Cycle.....	69
11.1 Measurement procedure.....	69
11.2 Limit.....	69
11.3 Measurement result.....	69
11.4 Trace data.....	71
12. Antenna requirement.....	75
13. Uncertainty of measurement.....	76
14. Laboratory description.....	77
Appendix A. Test equipment.....	78
Appendix B. Spurious plot data.....	79

1. Summary of Test

1.1 Purpose of test

It is the original test in order to verify conformance to FCC Part 15 Subpart E and IC RSS-247

1.2 Standards

CFR47 FCC Part 15 Subpart E
IC RSS-247

1.2.1 Test Methods

ANSI C63.10-2013, KDB789033 D02 General UNII Test Procedures New Rules v01r01

1.2.2 Deviation from standards

None

1.3 List of applied test to the EUT

FCC Section	IC Section	Test items	Condition	Result
15.407(a)	RSS-247 6.2.2	26dB Bandwidth	Conducted	PASS
15.407(e)	RSS-247 6.2.4	6dB Bandwidth	Conducted	PASS
15.407(a)	RSS-247 6.2 6.2.4	Maximum Conducted Output Power	Conducted	PASS
15.407(a)	RSS-247 6.2 6.2.4	Peak Power Spectral Density	Conducted	PASS
15.407(b) 15.205 15.209	RSS-Gen 8.9	Radiated emissions (Restricted Bands of Operation)	Radiated	PASS
15.407(g)	RSS-Gen 6.11	Frequency Stability	Conducted	PASS
15.207	RSS-Gen 8.8	AC Power Line Conducted Emissions	Conducted	PASS

1.3.1 Test set up

Table-Top

1.4 Modification to the EUT by laboratory

None



2. Equipment Under Test

2.1 General Description of equipment

EUT is the Wireless LAN module.

2.2 EUT information

Applicant	:	Seiko Instruments Inc. 8,Nakase 1-chome, Mihama-ku Chiba-shi 261-8507 Chiba, Japan Phone: +81-43-211-1148
Equipment under test	:	Wireless LAN module
Trade name	:	SII
Model number	:	IFWL-001
Serial number	:	0011E5062AB1 (Radiated) 0011E5062AAA (Conducted)
EUT condition	:	Pre-Production
Power ratings	:	Battery: DC 3.3V
Size	:	(W) 53.1 × (D) 35.4 × (H) 6.41 mm
Environment	:	W52 : Indoor Only W53, W56, W58 : Indoor and Outdoor use
Thermal limitation	:	-20°C to 55°C
RF Specification Protocol	:	IEEE802.11a, IEEE802.11n (HT20)
Frequency range	:	IEEE802.11a/n (HT20): 5180MHz-5320MHz, 5500MHz-5700MHz, 5745MHz-5825MHz
Number of RF Channels	:	IEEE802.11a/n (HT20): 25 Channels
Modulation type	:	IEEE802.11a/n: OFDM (BPSK, QPSK, 16QAM, 64QAM, 256QAM)
Data rate	:	IEEE802.11a: 6, 9, 12, 18, 24, 36, 48, 54 Mbps IEEE802.11n (HT20 LGI): 6.5, 13, 19.5, 26, 39, 52, 58.5, 65Mbps
Channel separation	:	IEEE802.11a/n (HT20): 20MHz
Output power	:	47.515mW (IEEE802.11a) 47.290mW (IEEE802.11n: HT20)
Antenna type	:	Chip antenna
Antenna gain	:	5.15-5.25GHz ,5.25-5.35GHz band: 2.6dBi 5.47-5.725GHz band: 1.9dBi 5.725-5.825GHz band: 2.5dBi



Zacta

2.3 Variation of the family model(s)

Not applicable

2.4 Operating channels and frequencies

[IEEE802.11a/n (HT20)]

Channel	Frequency [MHz]
36	5180
40	5200
44	5220
48	5240
52	5260
56	5280
60	5300
64	5320
100	5500
104	5520
108	5540
112	5560
116	5580
120	5600
124	5620
128	5640
132	5660
136	5680
140	5700
144	5720
149	5745
153	5765
157	5785
161	5805
165	5825

2.5 Operating mode

The EUT had been tested under operating condition.
There are three channels have been tested as following:

Band	IEEE802.11a/n/ac (HT20)	
	Channel	Frequency [MHz]
5.2GHz Band	36	5180
	40	5200
	48	5240
5.3GHz Band	52	5260
	56	5280
	64	5320
5.6GHz Band	100	5500
	120	5600
	140	5700
5.8GHz Band	149	5745
	157	5785
	165	5825

The pre-test has been conducted to determine the worst-case mode from all possible combinations between available modulations, data rates.

Band	Modulation Type	Data Rate
5.2GHz Band	IEEE802.11a: OFDM	6Mbps
	IEEE802.11n (HT20): OFDM	MCS0 (6.5Mbps)
5.3GHz Band	IEEE802.11a: OFDM	6Mbps
	IEEE802.11n (HT20): OFDM	MCS0 (6.5Mbps)
5.6GHz Band	IEEE802.11a: OFDM	6Mbps
	IEEE802.11n (HT20): OFDM	MCS0 (6.5Mbps)
5.8GHz Band	IEEE802.11a: OFDM	6Mbps
	IEEE802.11n (HT20): OFDM	MCS0 (6.5Mbps)

The field strength of spurious emissions was measured at each position of all three axis X, Y and Z to compare the level, and the maximum noise.

The worst emission was found in Z axis and the worst case recorded.

2.6 Operating mode

[Tx mode]

- i) The setting of communication with Putty-062.exe and tftpd32.exe
- ii) Test program setup to the artgui.exe
- iii) Select a Test mode
Operating frequency: 5.2GHz Band, 5.3GHz Band, 5.6GHz Band, 5.8GHz Band
- iv) Start test mode

[Rx mode]

- i) The setting of communication with Putty-062.exe and tftpd32.exe
- ii) Test program setup to the artgui.exe
- iii) Select a Test mode
Operating frequency: 5.2GHz Band, 5.3GHz Band, 5.6GHz Band, 5.8GHz Band
- iv) Start test mode

3. Configuration of equipment

3.1 Equipment(s) used

No.	Equipment	Company	Model No.	Serial No.	FCC ID / DoC	Comment
1	Wireless LAN module	SII	IFWL-001	0011E5062AB1	C4ZAB000005	EUT
2	Test board	SII	N/A	No.2	N/A	Host device
3	Conversion adapter(USB-LAN)	N/A	N/A	N/A	N/A	Accessory
4	Personal computer	FUJITSU	FMVNC4DC3	R7101676	DoC	-
5	AC adapter	FUJITSU	ADP-60ZH A	CP281868-01	N/A	-
6	AC adapter	SII	NU50-20933400-13	N/A	N/A	Accessory
7	DC Power supply	KIKUSUI	PAB32-2	47306490	N/A	-

3.2 Cable(s) used

No.	Cable	Length[m]	Shield	Connector	Comment
a	Flat cable	0.025	NO	Metal	-
b	Signal cable	0.1	NO	Plastic	-
c	USB cable of Conversion adapter	0.1	YES	Metal	-
d	LAN cable	2.0	NO	Plastic	-
e	Serial cable	1.7	YES	Metal	-
f	DC cable of AC adapter for PC	1.9	YES	Metal	-
g	AC power cord of AC adapter for PC	1.7	NO	Plastic	-
h	DC cable of AC adapter for test board	1.8	YES	Metal	-
i	AC power cord of AC adapter for test board	1.7	NO	Plastic	-
j	DC cable of Test board	0.5	NO	Plastic	-
k	DC cable of DC power supply	1.4	NO	Plastic	-
l	AC power cable of DC power supply	2.0	NO	Plastic	-

3.3 System configuration

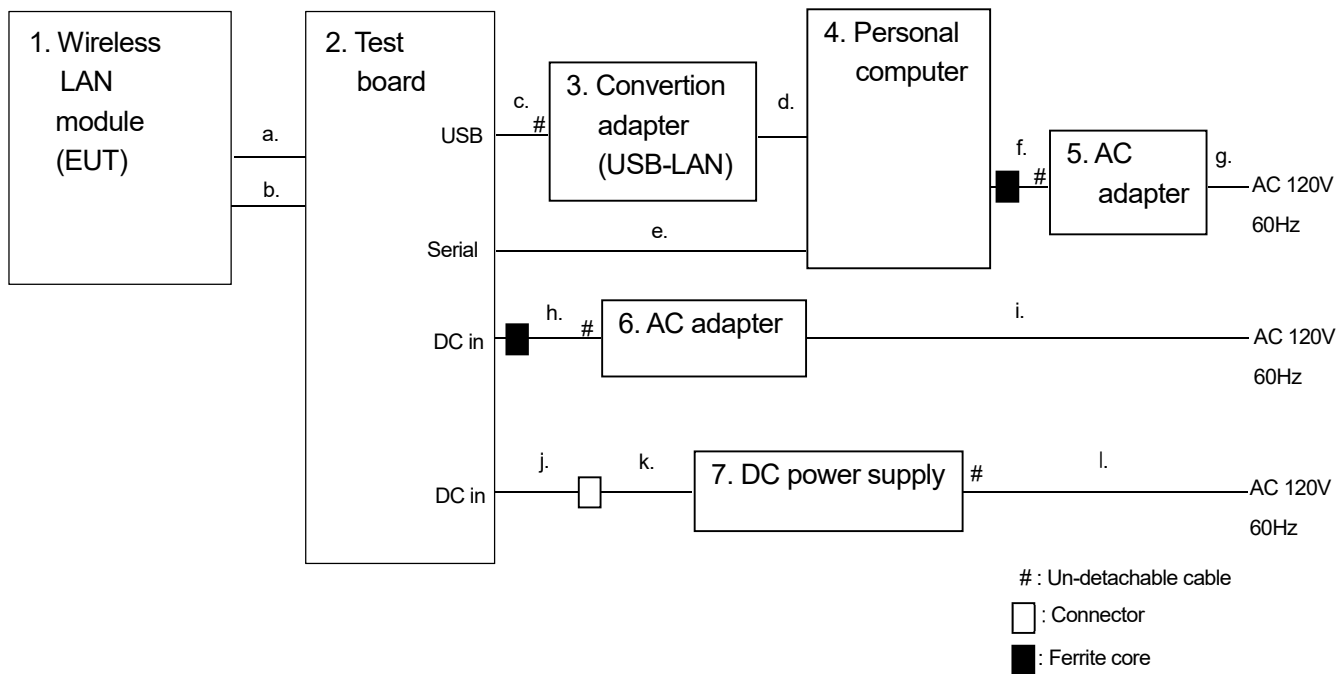

Note1: Numbers assigned to equipment or cables on this diagram correspond to the list in "3.1 Equipment(s) used" and "3.2 Cable(s) used".

Note2: One ferrite core for DC cable (No.f) is not an accessory of EUT.

Note3: One ferrite core of DC cable (No.h) is accessory of AC adapter (No.6).

4. 26dB Bandwidth and 99% Occupied Bandwidth

4.1 Measurement procedure

[FCC 15.407(a), RSS-247 6.2.2, KDB 789033 D02, Section C, D]

The 26dB bandwidth and 99% occupied bandwidth is measured with a spectrum analyzer connected to the antenna terminal, while EUT is operating in transmission mode at the appropriate center frequency.

The spectrum analyzer is set to;

- a) RBW = 1 % to 5 % of the OBW
- b) VBW $\geq 3 \cdot$ RBW
- c) span = 1.5 times to 5.0 times the OBW.
- d) Detector = Peak
- e) Trace mode = max hold

The EUT was set to operate with following conditions.

- 5.2GHz Band, 5.3GHz Band, 5.6GHz Band, 5.8GHz Band

The test mode of EUT is as follows.

- Tx mode

- Test configuration

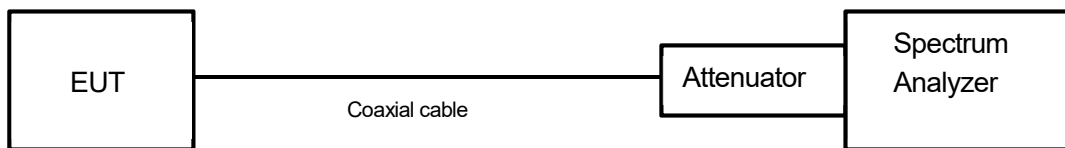

4.2 Limit

None

4.3 Measurement result

Date : January 25, 2016
 Temperature : 22.5 [°C]
 Humidity : 48.3 [%]
 Test place : Shielded room No.4

Test engineer :

Kazunori Saito



Zacta

Mode	Band	Channel	Frequency (MHz)	26dB bandwidth (MHz)	99% Occupied bandwidth (MHz)
802.11a	5.2GHz Band	36	5180	27.609	16.8525
		40	5200	28.704	16.7849
		48	5240	27.417	16.8717
	5.3GHz Band	52	5260	27.623	16.9163
		56	5280	27.925	16.8330
		64	5320	27.684	16.8197
	5.6GHz Band	100	5500	27.483	16.8600
		120	5600	27.807	16.8294
		140	5700	25.851	16.7720
	5.8GHz Band	149	5745	31.593	17.0803
		157	5785	30.091	17.1942
		165	5825	30.485	17.1255

Mode	Band	Channel	Frequency (MHz)	26dB bandwidth (MHz)	99% Occupied bandwidth (MHz)
802.11n (20MHz)	5.2GHz Band	36	5180	27.501	17.8785
		40	5200	29.782	17.9552
		48	5240	27.173	17.8962
	5.3GHz Band	52	5260	30.996	17.9825
		56	5280	28.962	17.9824
		64	5320	28.285	17.9483
	5.6GHz Band	100	5500	29.890	18.0051
		120	5600	29.428	17.9324
		140	5700	27.345	17.8996
	5.8GHz Band	149	5745	27.349	17.9749
		157	5785	28.865	17.9659
		165	5825	29.432	17.9644



Zacta

4.4 Trace data
[IEEE802.11a]
(5.2GHz Band)
Channel: 36

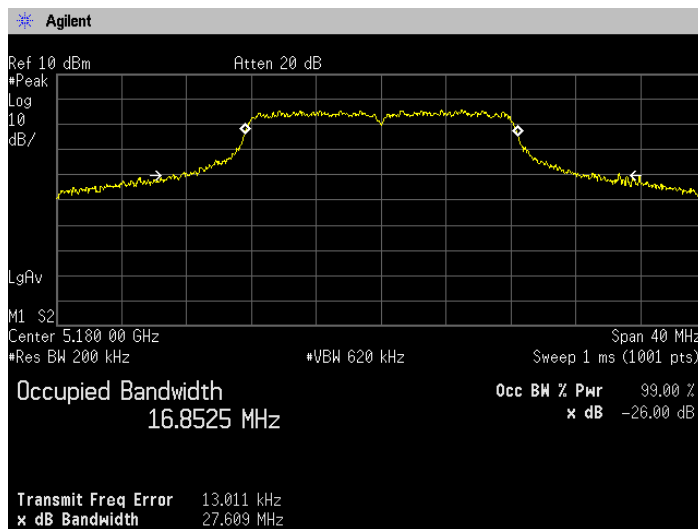

Channel: 40

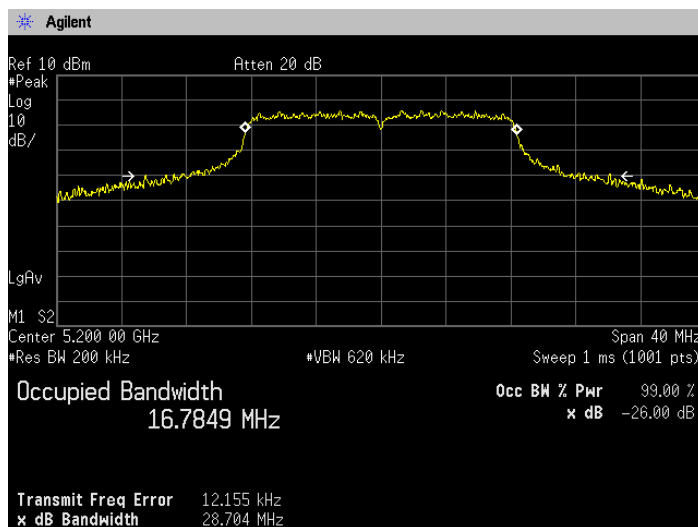

Channel: 48

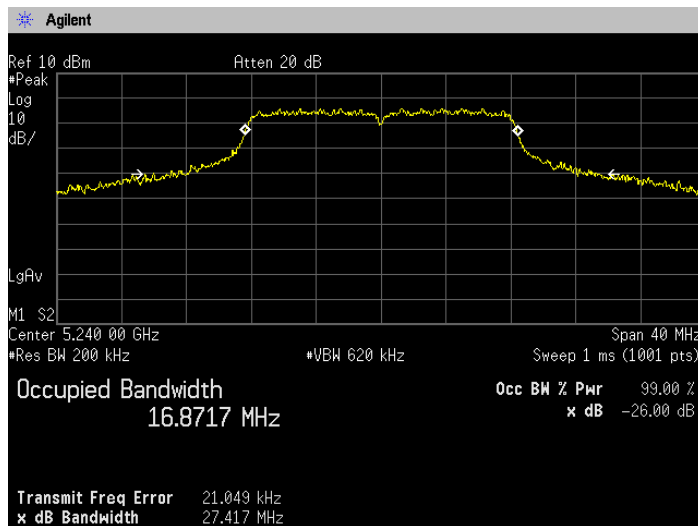



Zacta

**(5.3GHz Band)
Channel: 52**

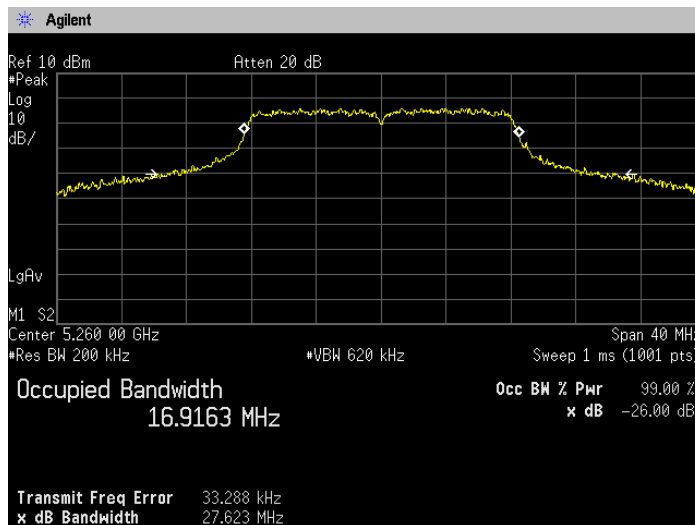

Channel: 56

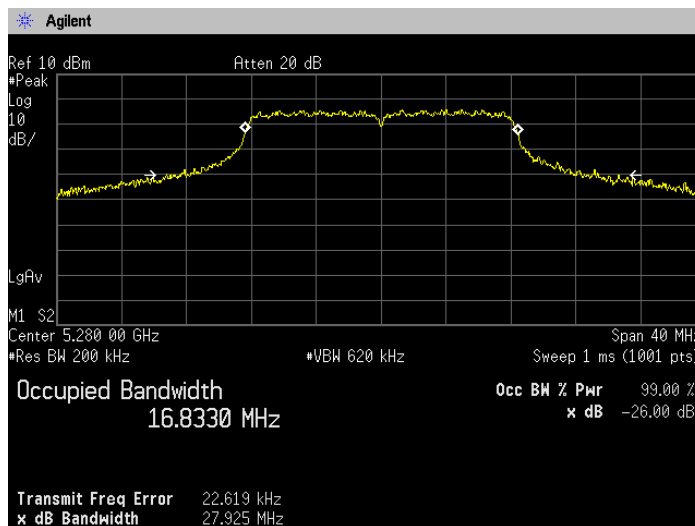

Channel: 64

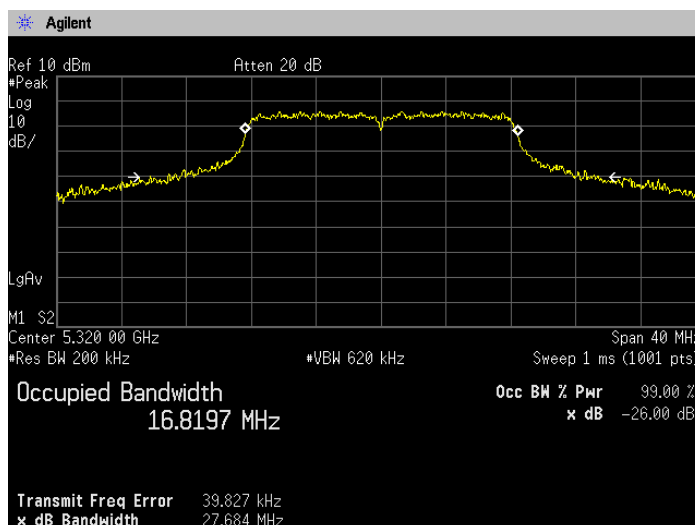



Zacta

**(5.6GHz Band)
Channel: 100**

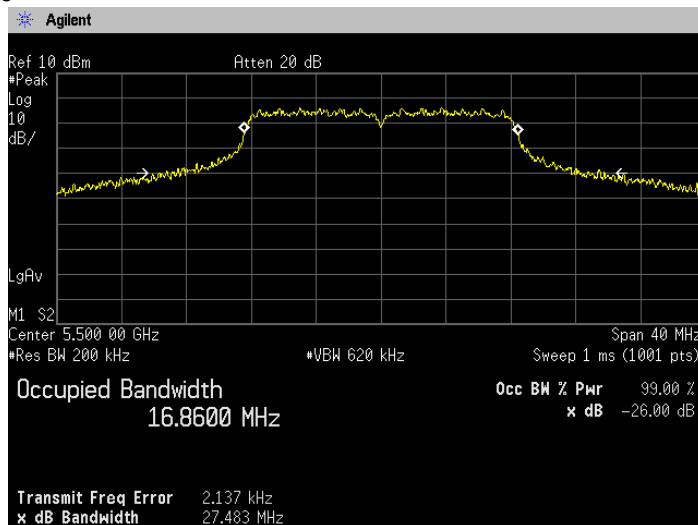

Channel: 120

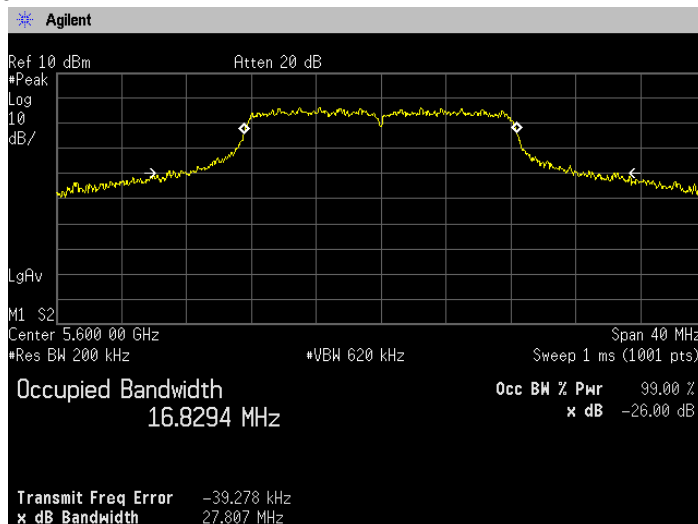

Channel: 140

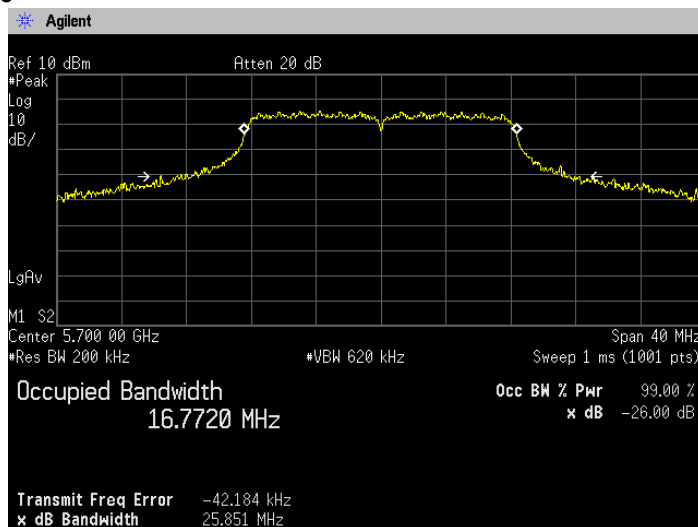



Zacta

(5.8GHz Band)

Channel: 149

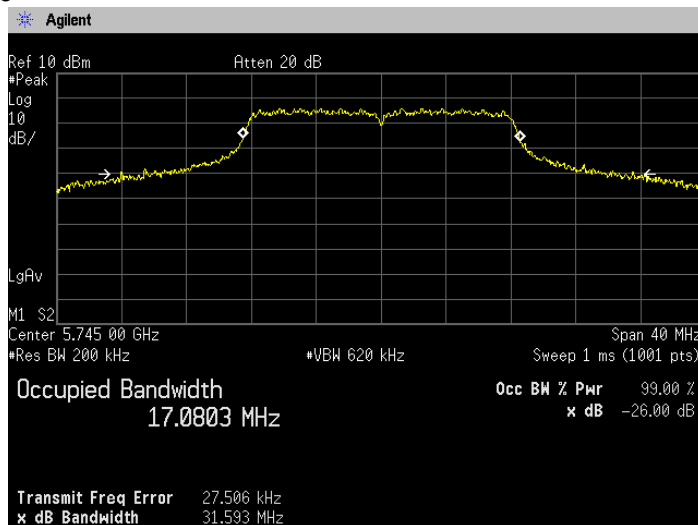

Channel: 157

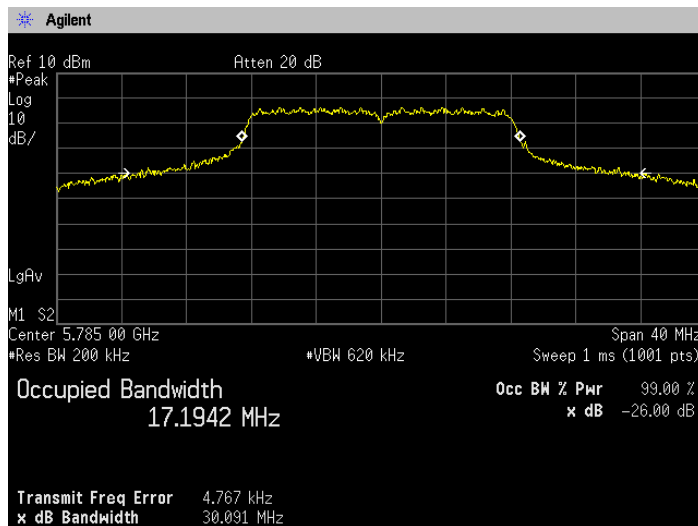

Channel: 165

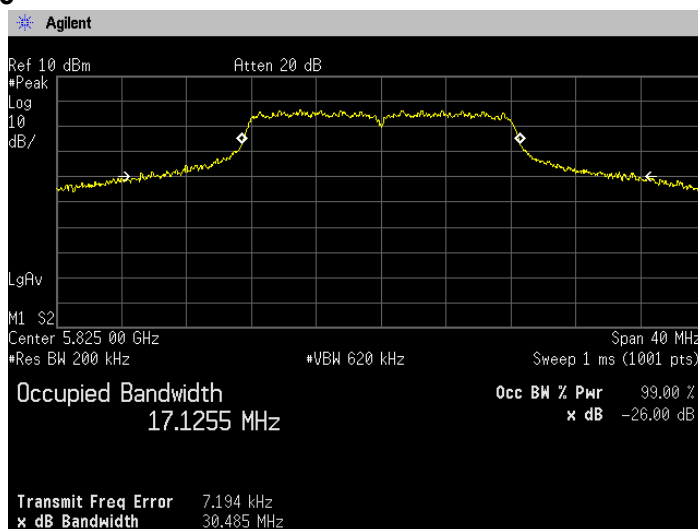



Zacta

**[IEEE802.11n(HT20)]
(5.2GHz Band)
Channel: 36**

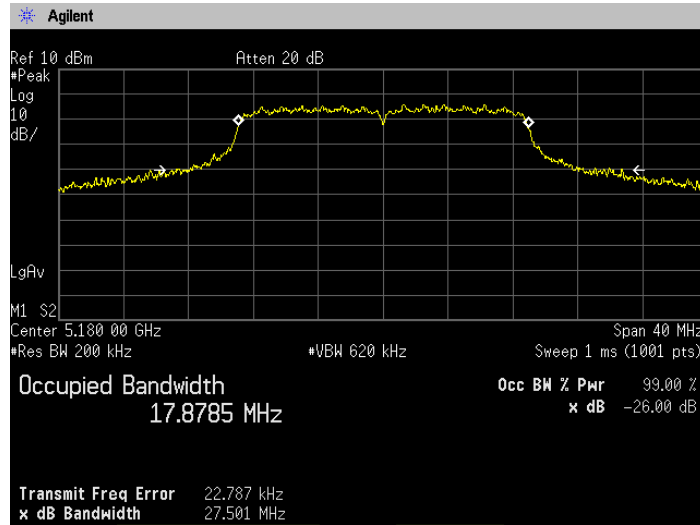

Channel: 40

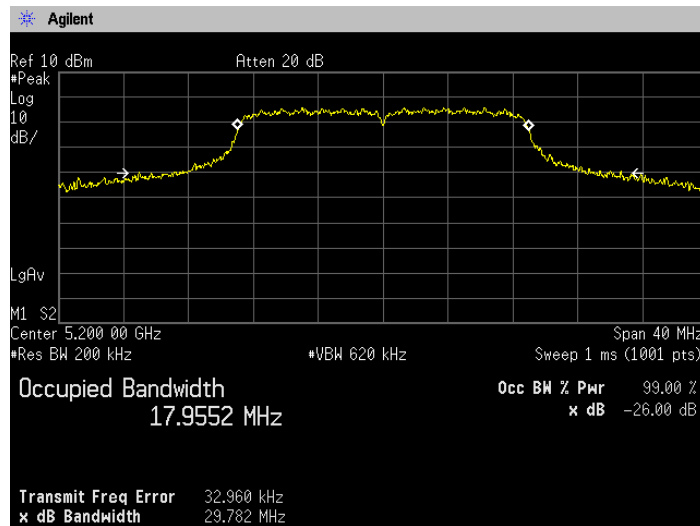

Channel: 48

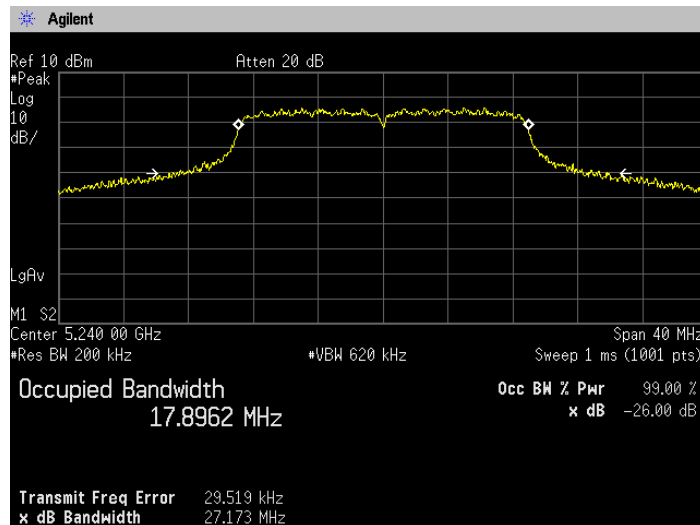



Zacta

**(5.3GHz Band)
Channel: 52**

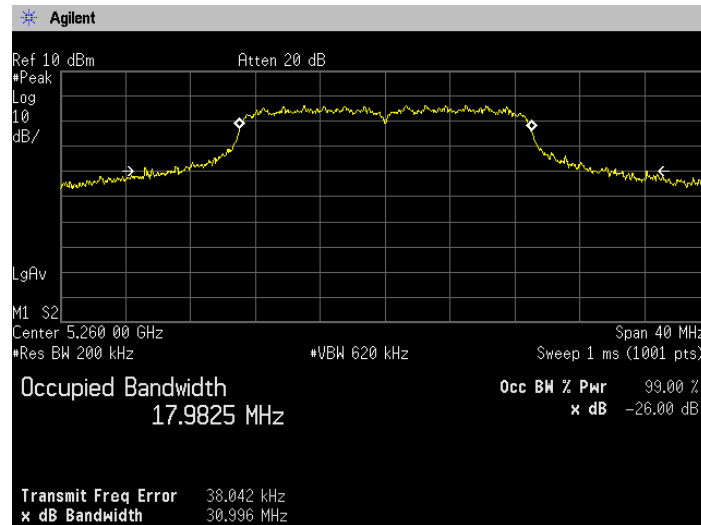

Channel: 56

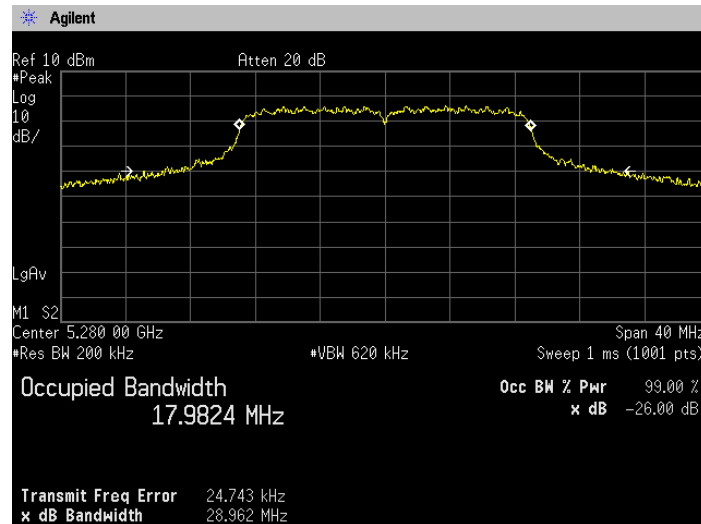

Channel: 64

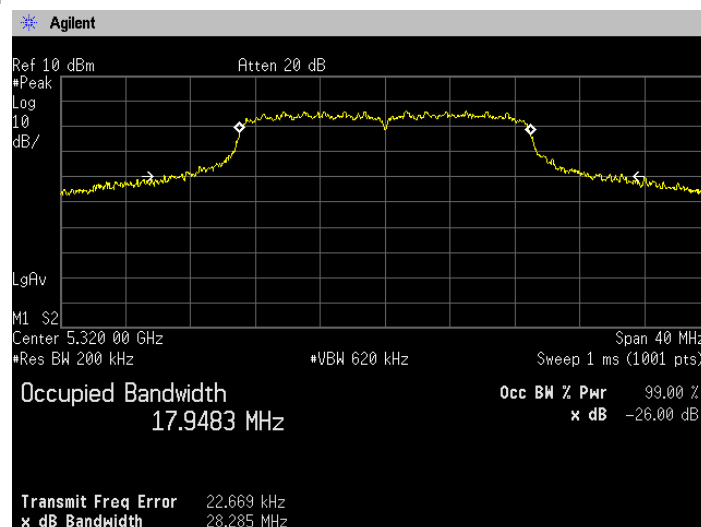



Zacta

**(5.6GHz Band)
Channel: 100**

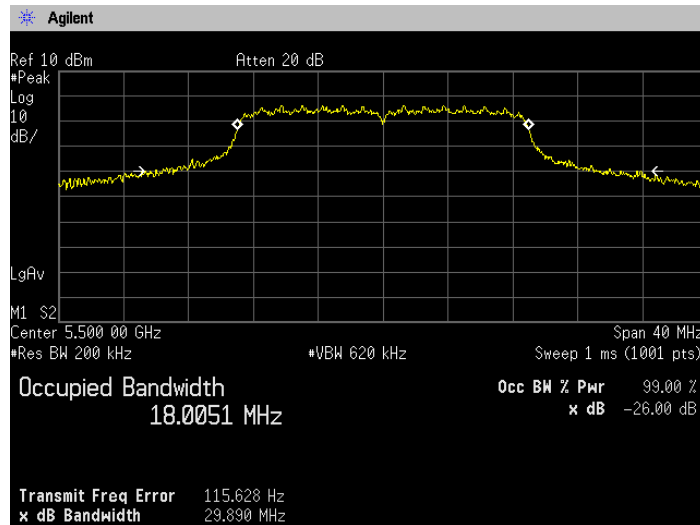

Channel: 120

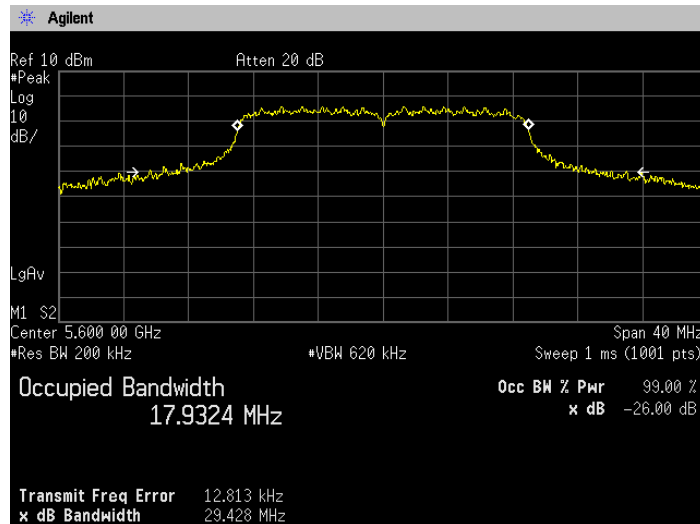

Channel: 140

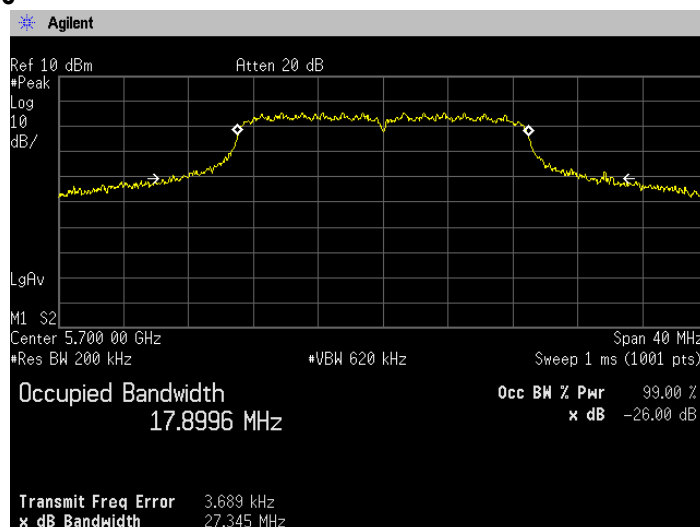



Zacta

**(5.8GHz Band)
Channel: 149**

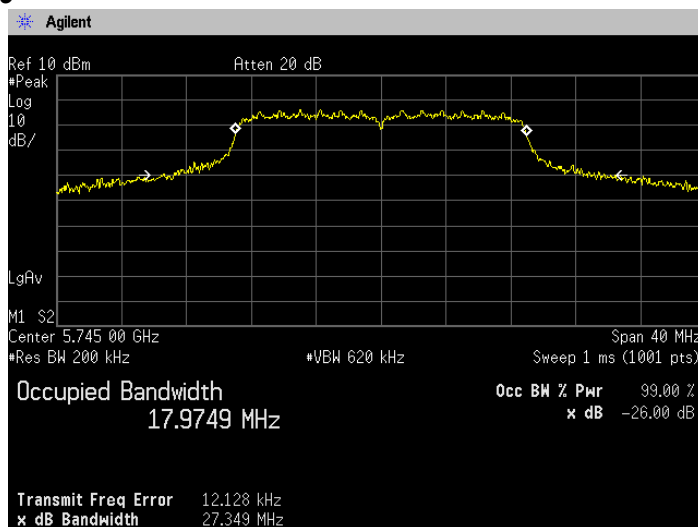

Channel: 157

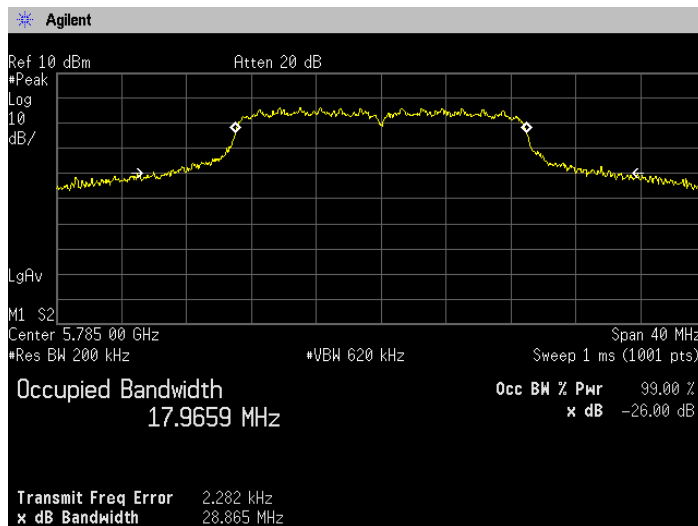

Channel: 165

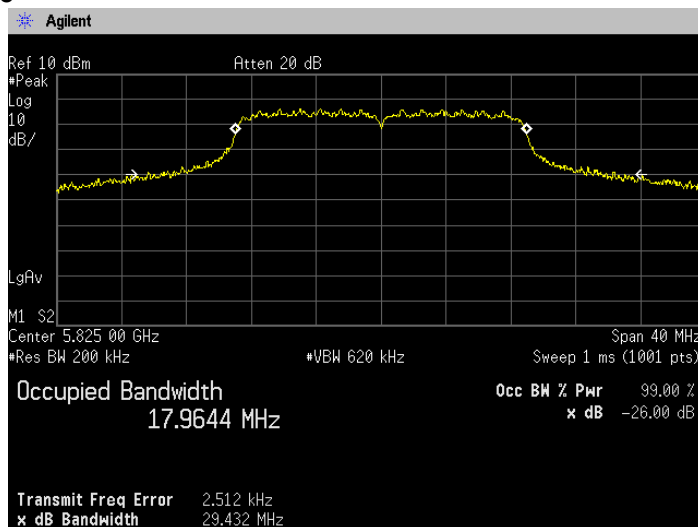

5. 6dB Bandwidth

5.1 Measurement procedure

[FCC 15.407(e), RSS-247 6.2.4, KDB 789033 D02, Section C]

The 6dB bandwidth is measured with a spectrum analyzer connected to the antenna terminal, while EUT is operating in transmission mode at the appropriate center frequency.

The spectrum analyzer is set to;

- RBW = 100kHz.
- $VBW \geq 3 \times RBW$.
- Detector = Peak..
- Trace mode = max hold.
- Sweep = auto couple

The EUT was set to operate with following conditions.

- 5.8GHz Band

The test mode of EUT is as follows.

- Tx mode
- Test configuration

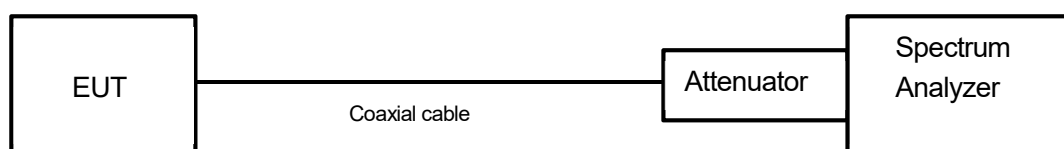

5.2 Limit

None

5.3 Measurement result

Date : January 25, 2016
 Temperature : 22.5 [°C]
 Humidity : 48.3 [%]
 Test place : Shielded room No.4

Test engineer : Kazunori Saito

Mode	Band	Channel	Frequency (MHz)	6dB bandwidth (MHz)
802.11a	5.8GHz Band	149	5745	16.078
		157	5785	16.069
		165	5825	16.091

Mode	Band	Channel	Frequency (MHz)	6dB bandwidth (MHz)
802.11n (20MHz)	5.8GHz Band	149	5745	16.953
		157	5785	16.696
		165	5825	16.692



Zacta

5.4 Trace data
[IEEE802.11a]
(5.8GHz Band)

Channel: 149

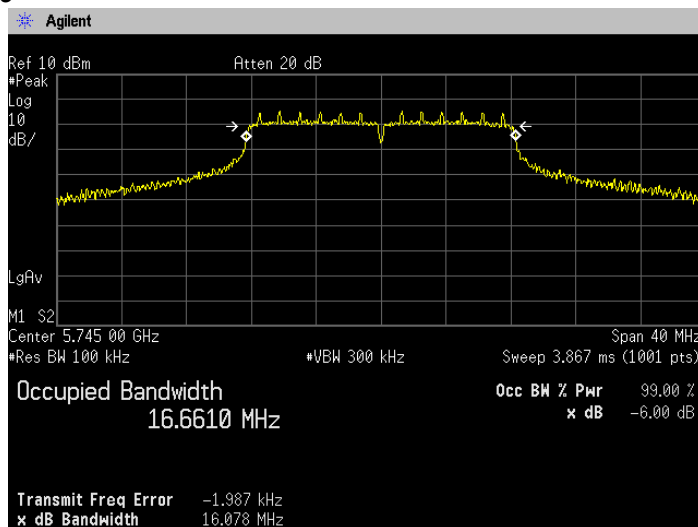

Channel: 157

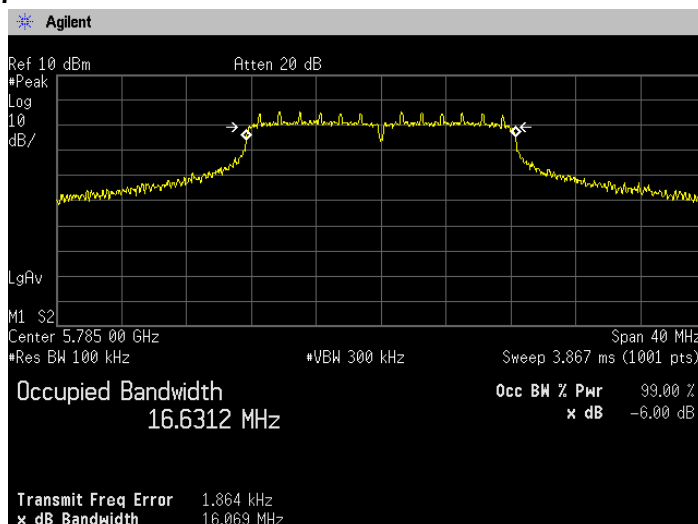

Channel: 165

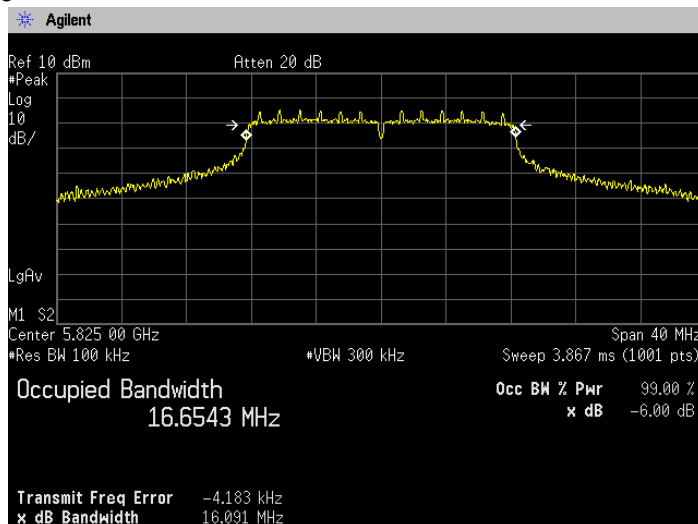



Zacta

**[IEEE802.11n_HT20]
(5.8GHz Band)
Channel: 149**

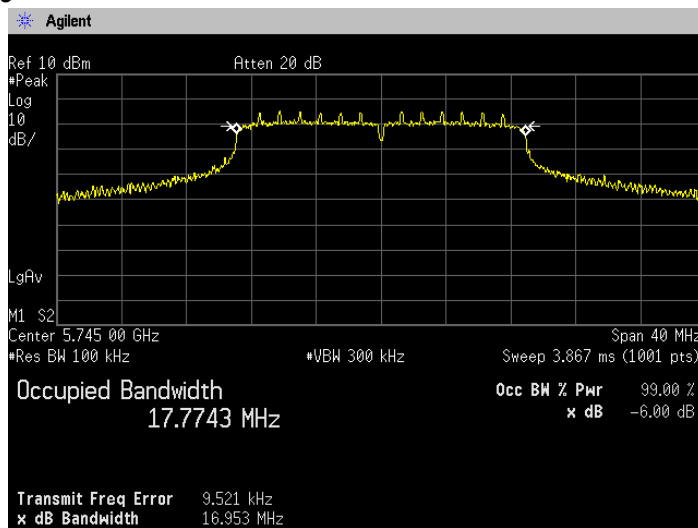

Channel: 157

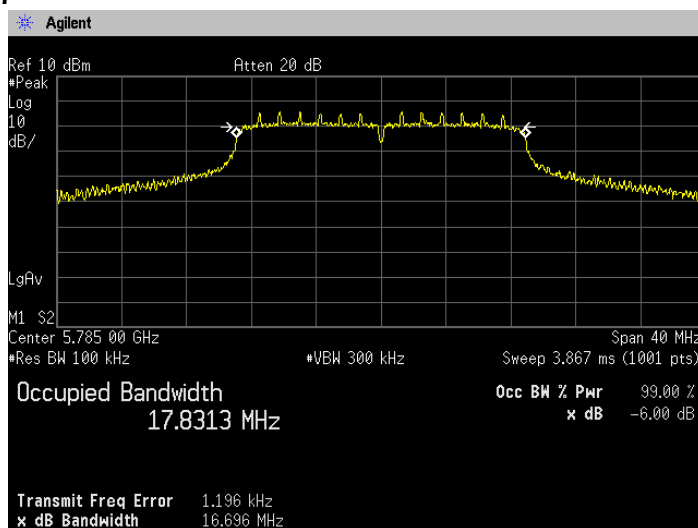

Channel: 165

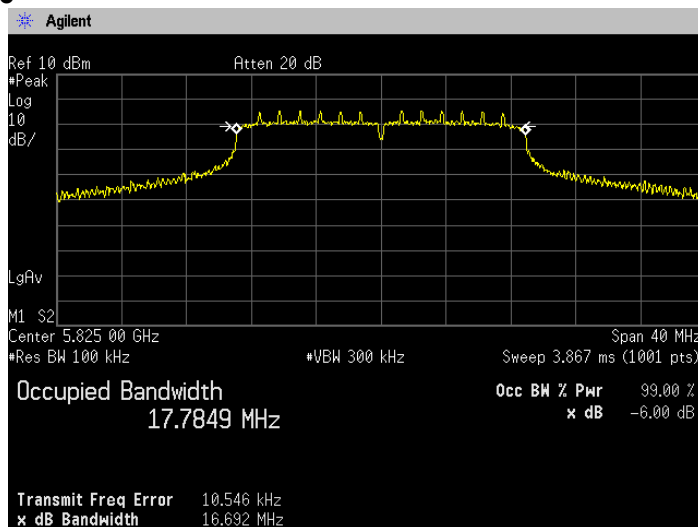

6. Maximum Conducted Output Power

6.1 Measurement procedure

[FCC 15.407(a), RSS-247 6.2, 6.2.4, KDB 789033 D02, Section E.2.b)Method SA-1, d)Method SA-2]

The peak power is measured with a spectrum analyzer connected to the antenna terminal, while EUT is operating in transmission mode at the appropriate center frequency.

The spectrum analyzer is set to;

- a) Set RBW = 1 MHz
- b) Set VBW \geq 3 MHz
- c) Sweep time = auto
- d) Detector = RMS
- e) Trace mode = Single, Averaging 100 count
- f) Points \geq 2 x Span / RBW

The EUT was set to operate with following conditions.

- 5.2GHz Band, 5.3GHz Band, 5.6GHz Band, 5.8GHz Band

The test mode of EUT is as follows.

- Tx mode

- Test configuration

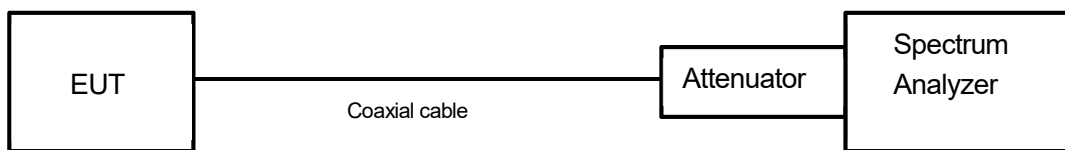

6.2 Limit

- (1) For mobile and portable client devices in the 5.15-5.25GHz band, the maximum conducted output power over the frequency band of operation shall not exceed 250mW provided the maximum antenna gain does not exceed 6dBi.
- (2) For the 5.25-5.35GHz and 5.47-5.725GHz bands, the maximum conducted output power over the frequency band of operation shall not exceed the lesser of 250mW or $11\text{dBm} + 10\log B$, where B is the 26dB emission bandwidth in megahertz.
- (3) For the 5.725-5.85GHz bands, the maximum conducted output power over the frequency band of operation shall not exceed 1W.

<Output Power Limit Calculation>

Band	Mode	Power Limit (mW)	Calculated Limit (dBm)	Antenna Gain (dBi)	Determined Limit (dBm)
5.2GHz Band	802.11a	250	23.97	2.6	23.97
	802.11n HT20				

Band	Mode	Power Limit (mW)	Calculated Limit (dBm)	Antenna Gain (dBi)	Determined Limit (dBm)
5.3GHz Band	802.11a	250	23.97	2.6	23.97
		27.623	25.41		
	802.11n HT20	250	23.97		
		28.285	25.52		

Band	Mode	Power Limit (mW)	Calculated Limit (dBm)	Antenna Gain (dBi)	Determined Limit (dBm)
5.6GHz Band	802.11a	250	23.97	1.9	23.97
		27.623	25.41		
	802.11n HT20	250	23.97		
		28.285	25.52		

Band	Mode	Power Limit (mW)	Calculated Limit (dBm)	Antenna Gain (dBi)	Determined Limit (dBm)
5.8GHz Band	802.11a	1000	30.00	2.5	30.00
	802.11n HT20				

6.3 Measurement result

Date : January 26, 2016
 Temperature : 22.8 [°C]
 Humidity : 46.0 [%]
 Test place : Shielded room No.4

Test engineer : Hikaru Shibata

Mode	Channel	Frequency (MHz)	Reading (dBm)	Duty Cycle			DCF (dB)	Test Result (dBm)	Test Result (mW)
				On Time(ms)	On+Off Time(ms)	X			
802.11a	36	5180	16.090	1.358	1.404	0.967	0.145	16.235	42.021
	40	5200	16.440					16.585	45.548
	48	5240	16.240					16.385	43.498
	52	5260	16.460	1.360	1.404	0.969	0.138	16.598	45.691
	56	5280	16.420					16.558	45.272
	64	5320	16.630					16.768	47.515
	100	5500	16.540	1.358	1.404	0.967	0.145	16.685	46.609
	120	5600	16.160					16.305	42.704
	140	5700	15.680					15.825	38.236
	149	5745	16.060	1.360	1.406	0.967	0.144	16.204	41.730
	157	5785	16.390					16.534	45.024
	165	5825	16.340					16.484	44.509

Note: X = On time / (On + Off time), DCF=10log (1/x)

Mode	Channel	Frequency (MHz)	Reading (dBm)	Duty Cycle			DCF (dB)	Test Result (dBm)	Test Result (mW)
				On Time(ms)	On+Off Time(ms)	X			
802.11n (20MHz)	36	5180	16.070	1.272	1.316	0.967	0.148	16.218	41.857
	40	5200	16.400					16.548	45.162
	48	5240	16.110					16.258	42.244
	52	5260	16.400	1.268	1.316	0.964	0.161	16.561	45.304
	56	5280	16.360					16.521	44.889
	64	5320	16.540					16.701	46.788
	100	5500	16.600	1.272	1.316	0.967	0.148	16.748	47.290
	120	5600	16.230					16.378	43.428
	140	5700	15.620					15.768	37.737
	149	5745	16.140	1.270	1.314	0.967	0.148	16.288	42.539
	157	5785	16.390					16.538	45.060
	165	5825	16.370					16.518	44.853

Note: X = On time / (On + Off time), DCF=10log (1/x)



Zacta

6.4 Trace data
[IEEE802.11a]
(5.2GHz Band)
Channel: 36

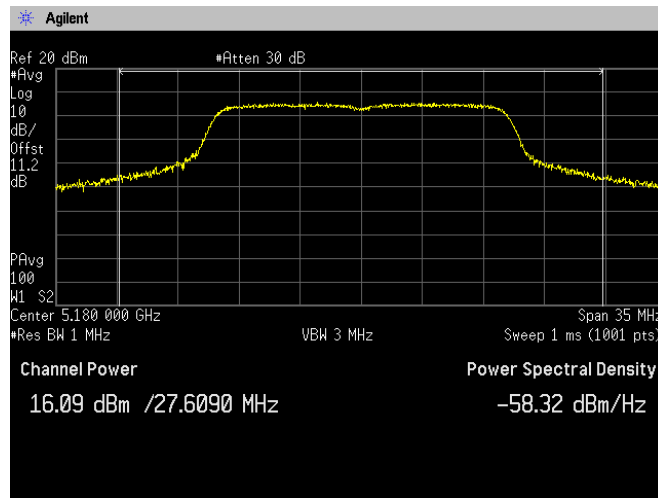

Channel: 40

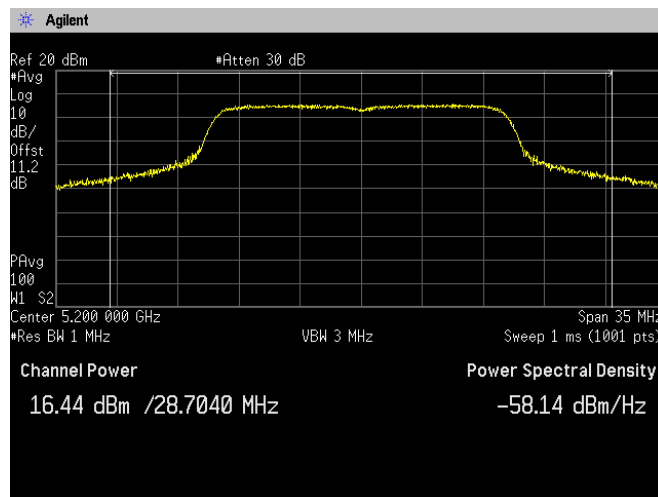

Channel: 48

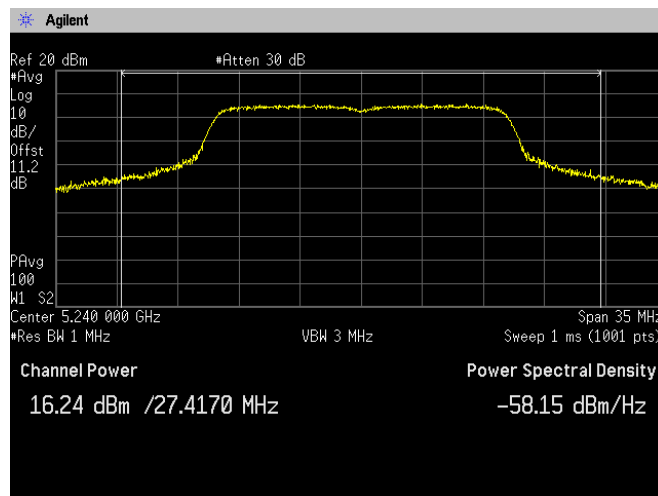



Zacta

**(5.3GHz Band)
Channel: 52**

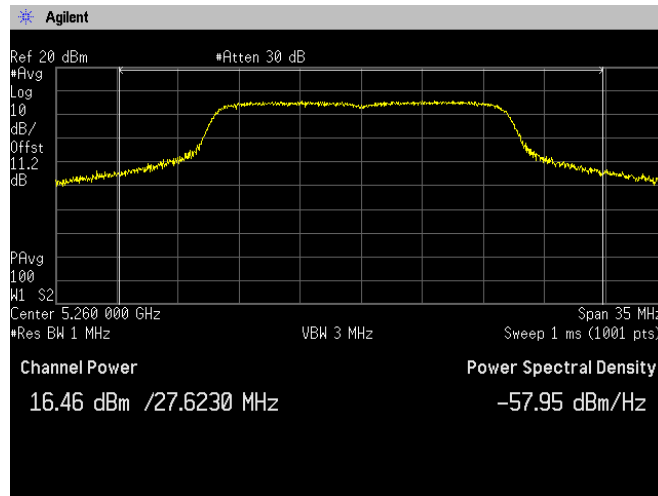

Channel: 56

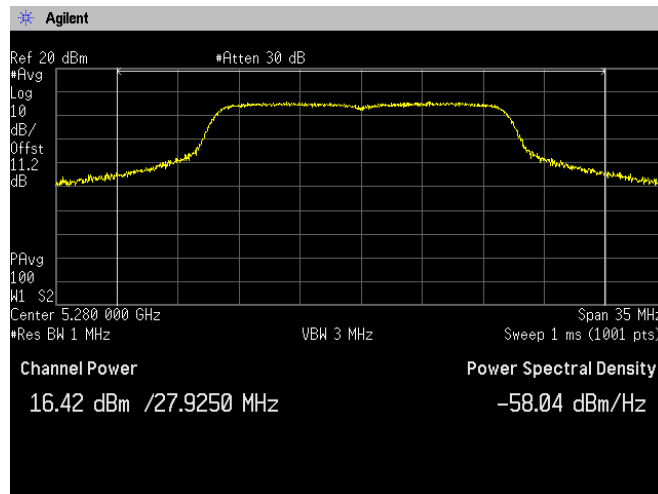

Channel: 64

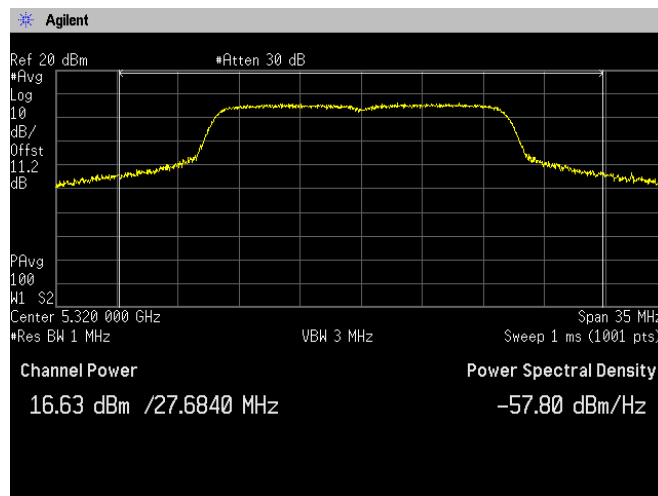



Zacta

**(5.6GHz Band)
Channel: 100**

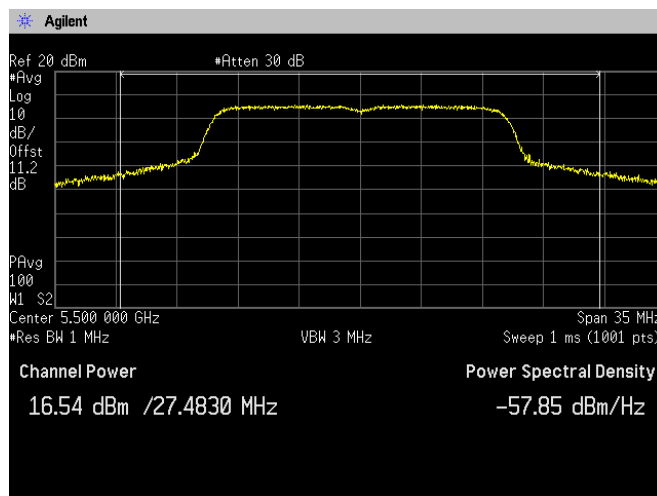

Channel: 120

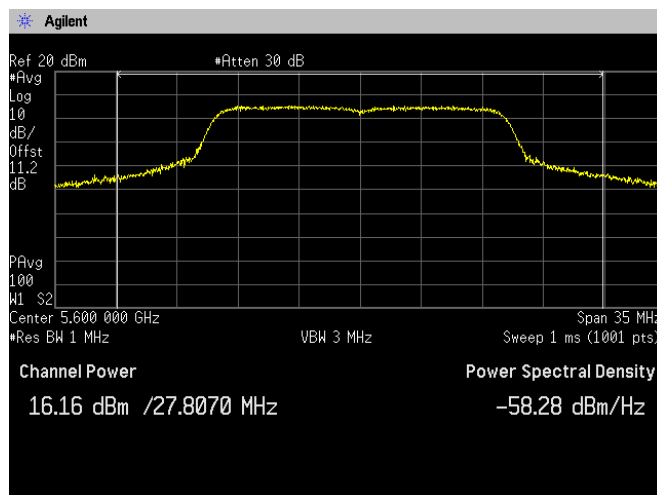

Channel: 140

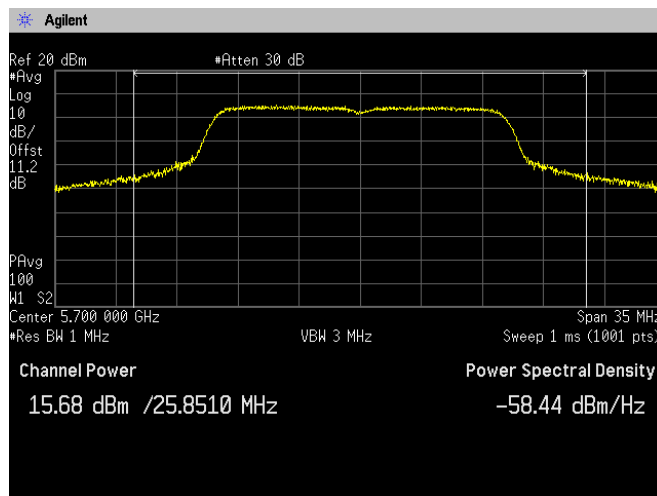



Zacta

(5.8GHz Band)
Channel: 149

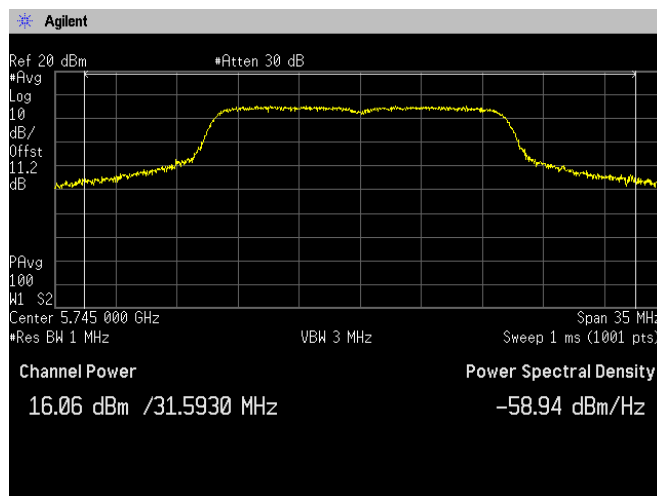

Channel: 157

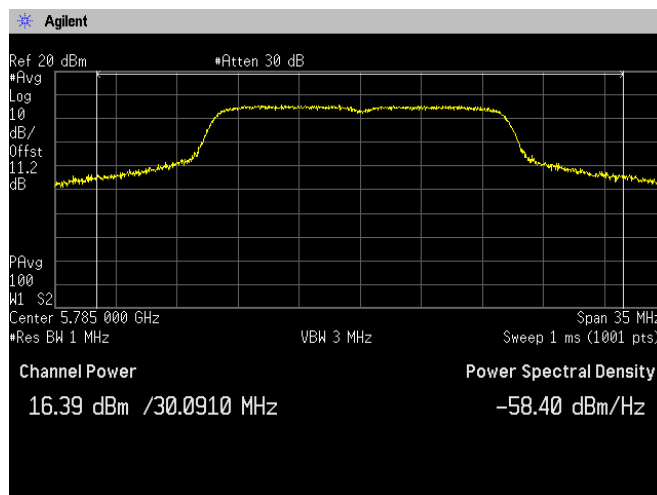

Channel: 167

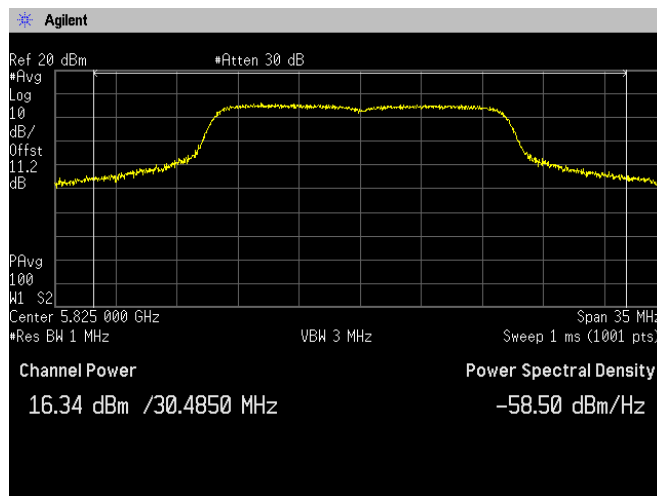



Zacta

**[IEEE802.11n (HT20)]
(5.2GHz Band)
Channel: 36**

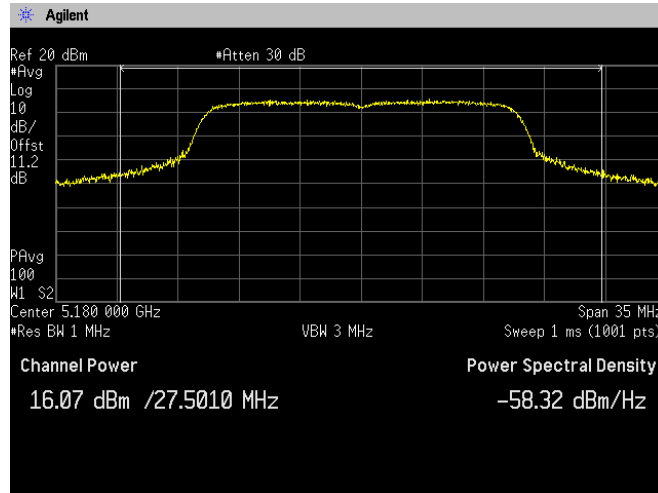

Channel: 40

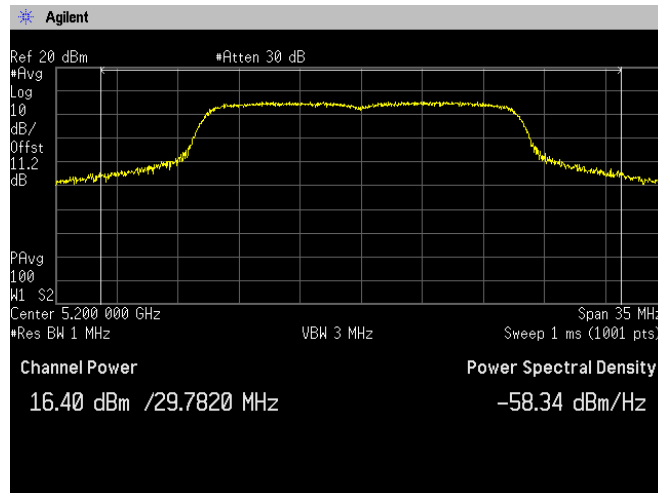

Channel: 48

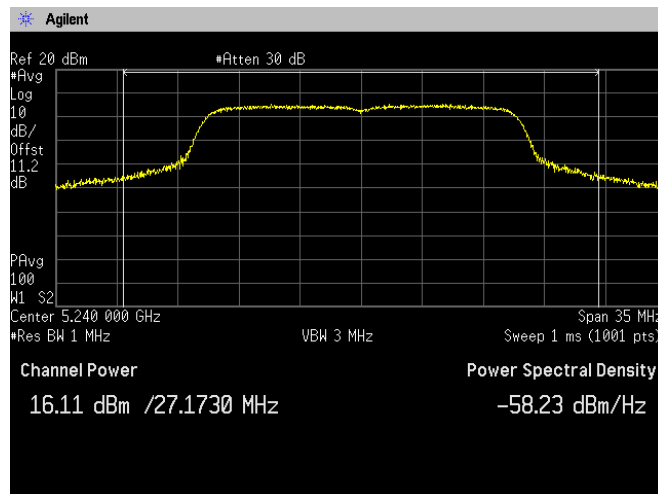



Zacta

**(5.3GHz Band)
Channel: 52**

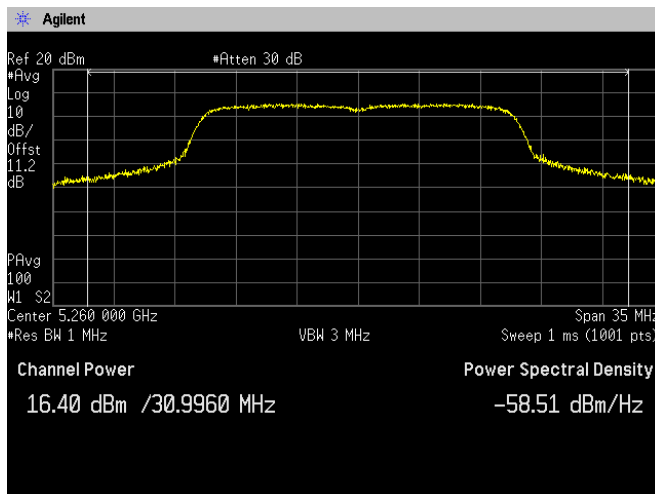

Channel: 56

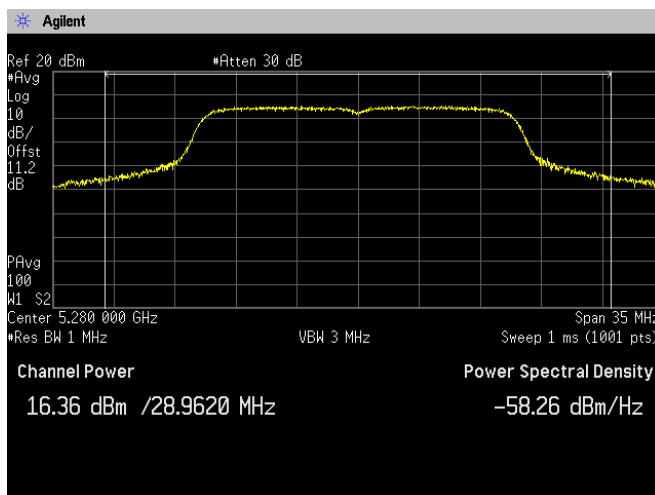

Channel: 64

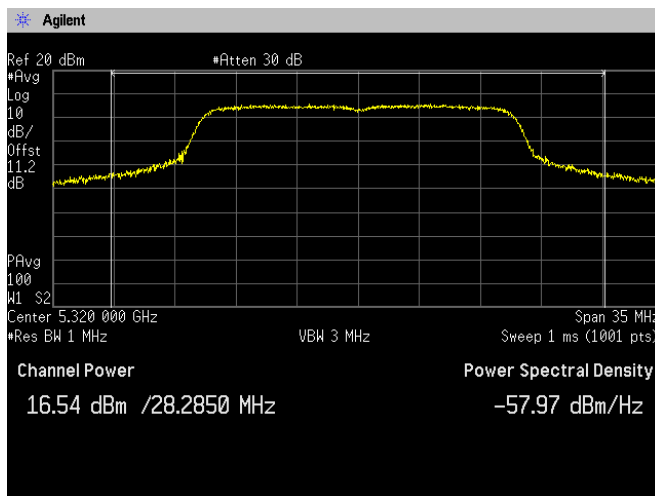



Zacta

**(5.6GHz Band)
Channel: 100**

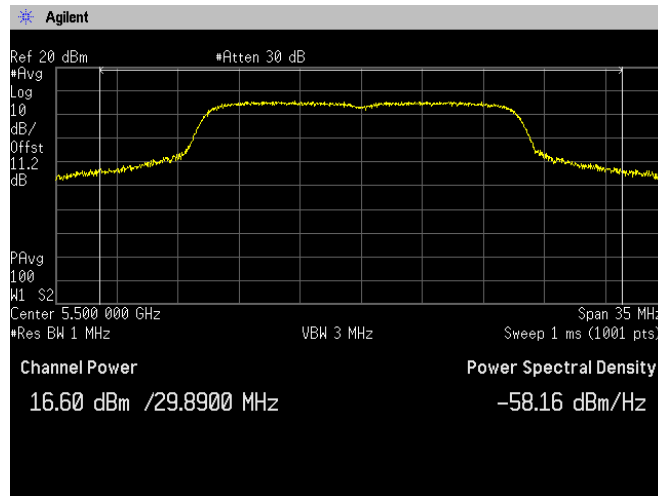

Channel: 120

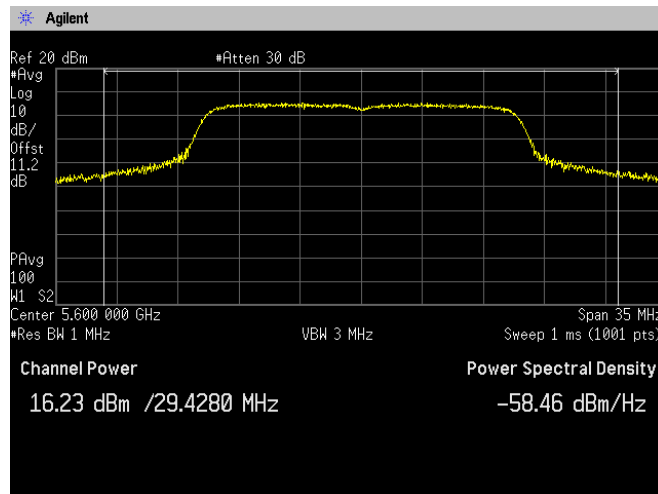

Channel: 140

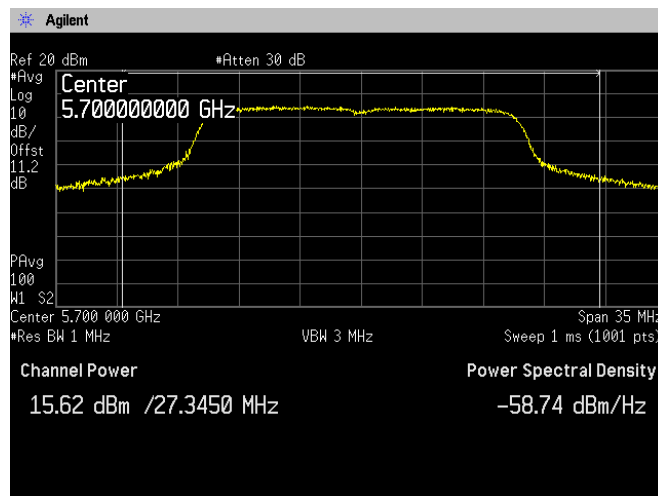



Zacta

**(5.8GHz Band)
Channel: 149**

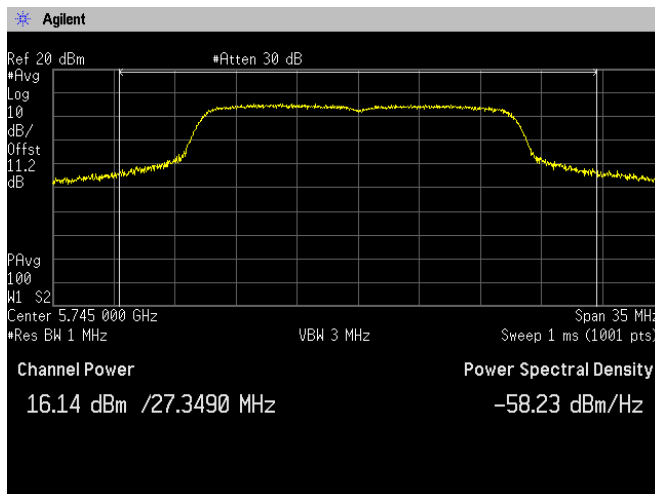

Channel: 157

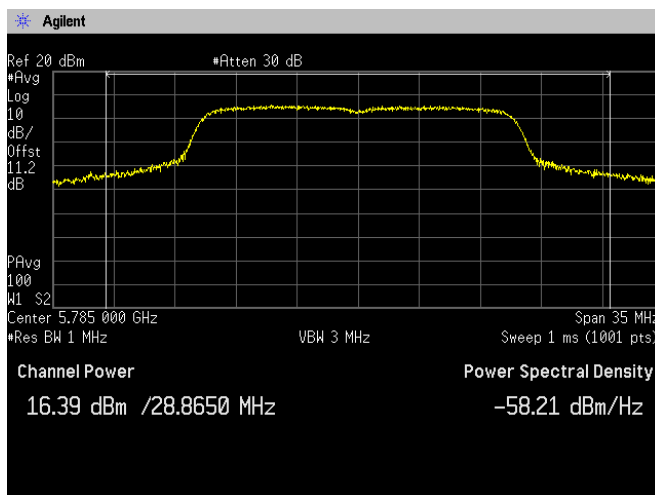

Channel: 165

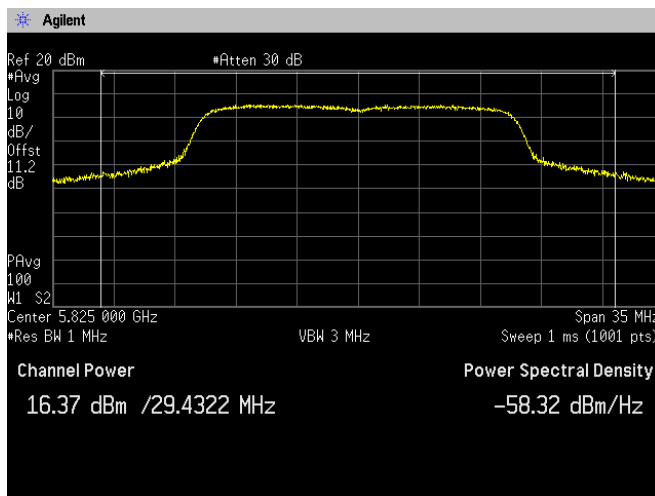

7. Peak Power Spectral Density

7.1 Measurement procedure

[FCC 15.407(a), RSS-247 6.2, 6.2.4, KDB 789033 D02, Section F]

The peak power spectral density is measured with a spectrum analyzer connected to the antenna terminal, while EUT is operating in transmission mode at the appropriate center frequency.

The spectrum analyzer is set to;

- a) Set RBW $\geq 1/T$,
- b) Set VBW ≥ 3 RBW,
- c) Sweep = auto,
- d) Sweep time = auto,
- e) Detector = RMS
- f) Trace mode = Averaging

The EUT was set to operate with following conditions.

- 5.2GHz Band, 5.3GHz Band, 5.6GHz Band, 5.8GHz Band

The test mode of EUT is as follows.

- Tx mode
- Test configuration

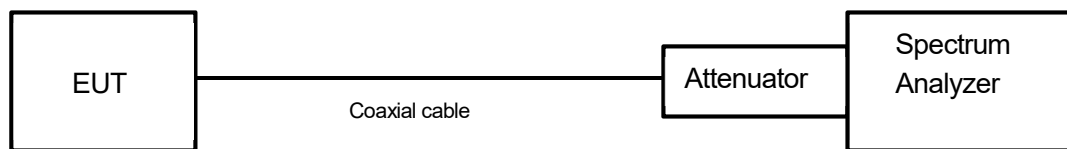

7.2 Limit

- (1) For mobile and portable client devices in the 5.15-5.25GHz band, the maximum power spectral density shall not exceed 11dBm in any 1 megahertz band. If transmitting antennas of directional gain greater than 6dBi are used, the peak power spectral density shall be reduced by the amount in dB that directional gain of the antenna exceeds 6dBi.
- (2) For the 5.25-5.35GHz and 5.47-5.725GHz bands, the maximum power spectral density shall not exceed 11dBm in any 1 megahertz band. If transmitting antennas of directional gain greater than 6dBi are used, the peak power spectral density shall be reduced by the amount in dB that directional gain of the antenna exceeds 6dBi.
- (3) For the 5.725-5.85GHz bands, the maximum power spectral density shall not exceed 30dBm in any 500-kHz band. If transmitting antennas of directional gain greater than 6dBi are used, both the maximum conducted output power and the maximum power spectral density shall be reduced by the amount in dB that directional gain of the antenna exceeds 6dBi. However, fixed point-to-point U-NII devices operating in this band may employ transmitting antennas with directional gain greater than 6dBi without any corresponding reduction in transmitter conducted power. Fixed, point-to-point operations exclude the use of point-to-multipoint systems, omnidirection applications, and multiple collocated transmitters transmitting the same information. The operator of the U-NII device, or if the equipment is professionally installer, is responsible for ensuring that systems employing high gain directional antennas are used exclusively for fixed, point-to-point operations.

<Peak Power Spectral Density Limit Calculation>

Band	Antenna Gain (dBi)	Limit
5.2GHz Band	2.6	11dBm/MHz
5.3GHz Band	2.6	11dBm/MHz
5.6GHz Band	1.9	11dBm/MHz
5.8GHz Band	2.5	30dBm/500kHz

7.3 Measurement result

Date : January 26, 2016
 Temperature : 22.8 [°C]
 Humidity : 46.0 [%]
 Test place : Shielded room No.4

Test engineer : Kazunori Saito

Mode	Channel	Frequency (MHz)	Reading (dBm)	Duty Cycle			DCF (dB)	Test Result (dBm)
				On Time(ms)	On+Off Time(ms)	X		
802.11a	36	5180	5.357	1.358	1.404	0.967	0.145	5.502
	40	5200	5.809					5.954
	48	5240	5.581					5.726
	52	5260	6.024	1.360	1.404	0.969	0.138	6.162
	56	5280	6.015					6.153
	64	5320	5.954					6.092
	100	5500	5.872	1.358	1.404	0.967	0.145	6.017
	120	5600	5.782					5.927
	140	5700	5.495					5.640
	149	5745	2.539	1.360	1.406	0.967	0.144	2.683
	157	5785	2.895					3.039
165	5825	3.055	3.199					

Note1: X = On time / (On + Off time), DCF=10log (1/x)

Note2: Test Result=Reading+ DCF

Mode	Channel	Frequency (MHz)	Reading (dBm)	Duty Cycle			DCF (dB)	Test Result (dBm)
				On Time(ms)	On+Off Time(ms)	X		
802.11n (20MHz)	36	5180	5.399	1.272	1.316	0.967	0.148	5.547
	40	5200	5.404					5.552
	48	5240	5.266					5.414
	52	5260	5.608	1.268	1.316	0.964	0.161	5.769
	56	5280	5.639					5.800
	64	5320	5.747					5.908
	100	5500	5.800	1.272	1.316	0.967	0.148	5.948
	120	5600	5.445					5.593
	140	5700	5.014					5.162
	149	5745	2.572	1.270	1.314	0.967	0.148	2.720
	157	5785	2.630					2.778
165	5825	2.696	2.844					

Note1: X = On time / (On + Off time), DCF=10log (1/x)

Note2: Test Result=Reading+ DCF



Zacta

7.4 Trace data
[IEEE802.11a]
(5.2GHz Band)
Channel: 36

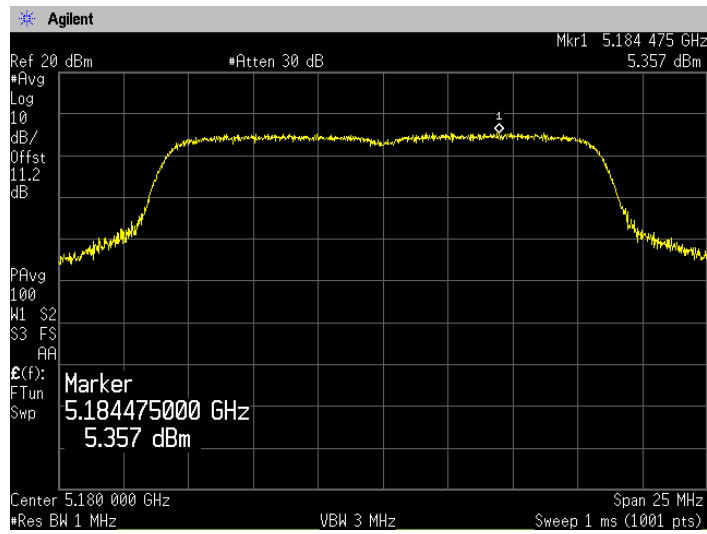

Channel: 40

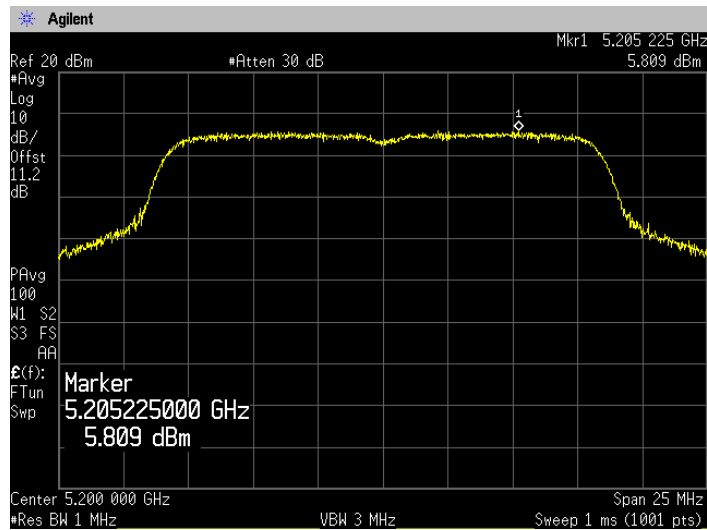

Channel: 48

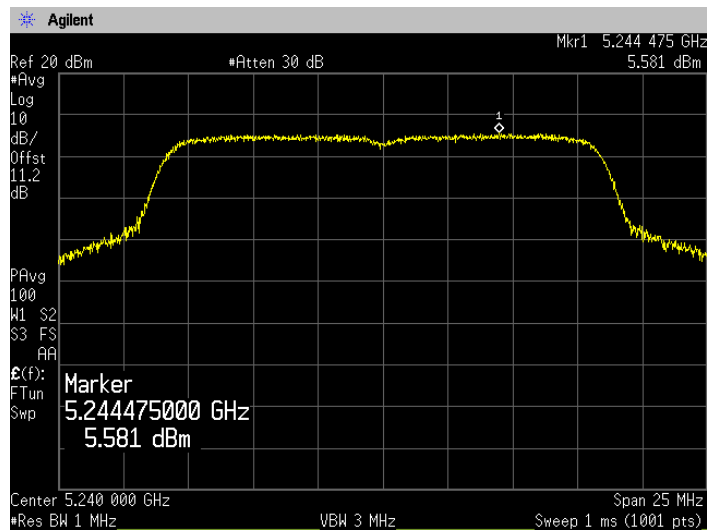



Zacta

(5.3GHz Band)
Channel: 52

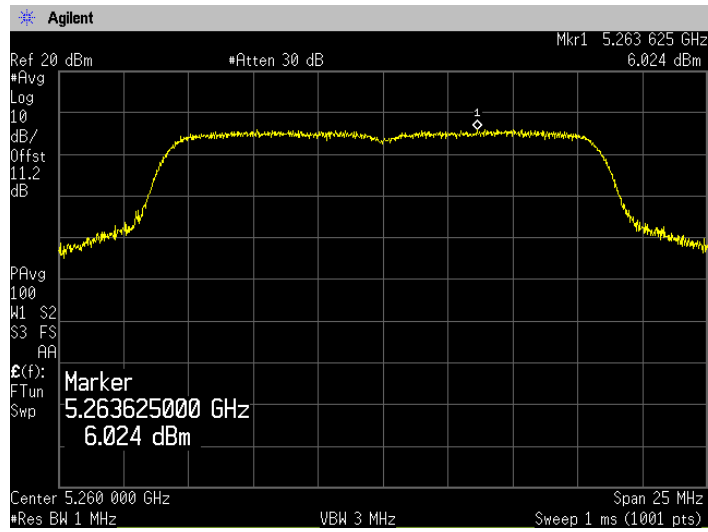

Channel: 56

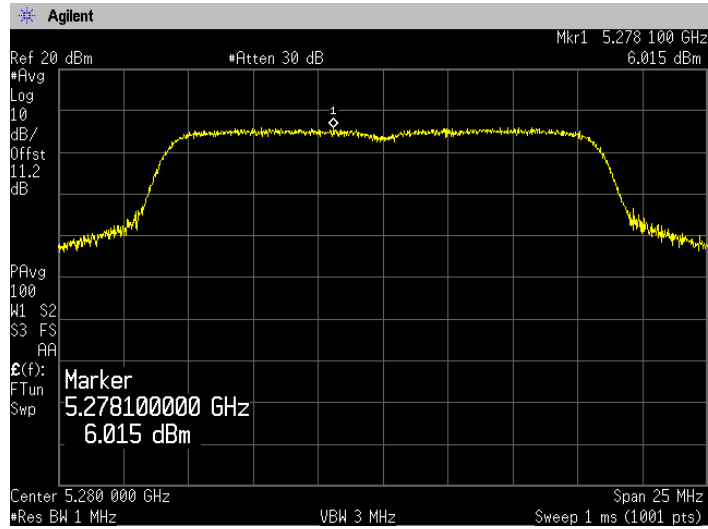

Channel: 64

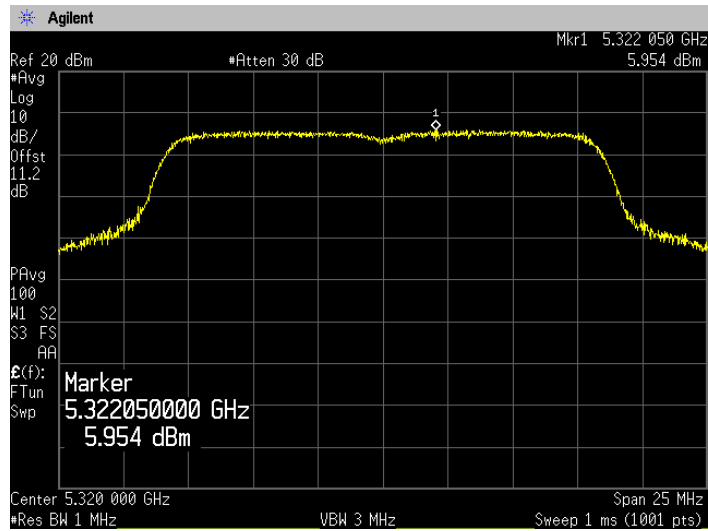



Zacta

(5.6GHz Band)
Channel: 100

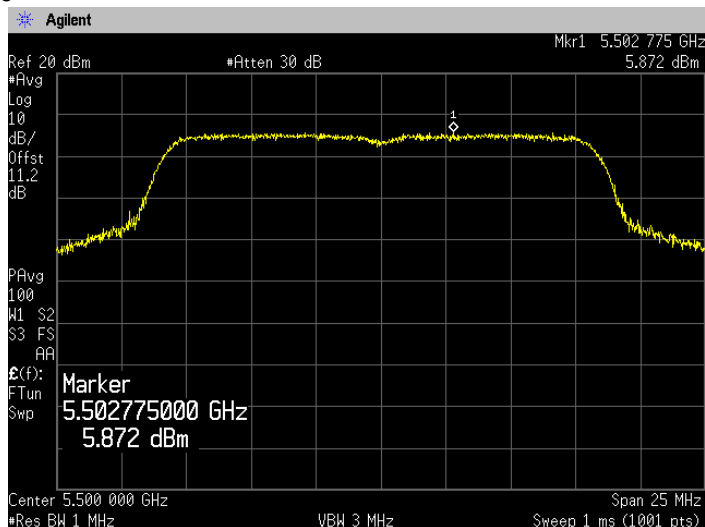

Channel: 120

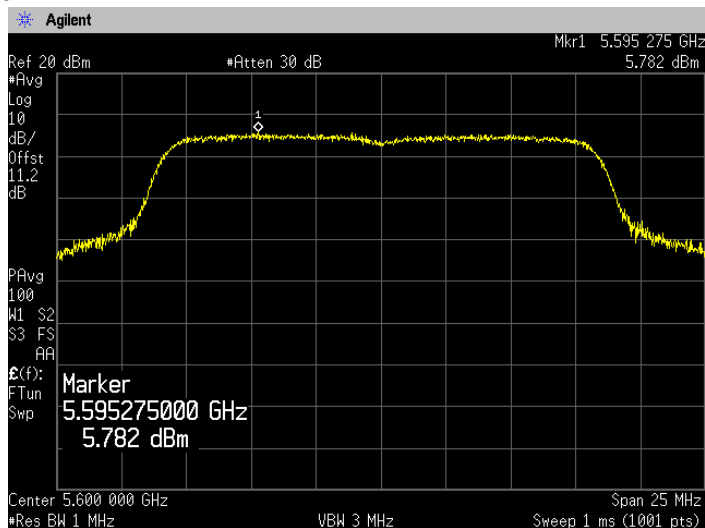

Channel: 140

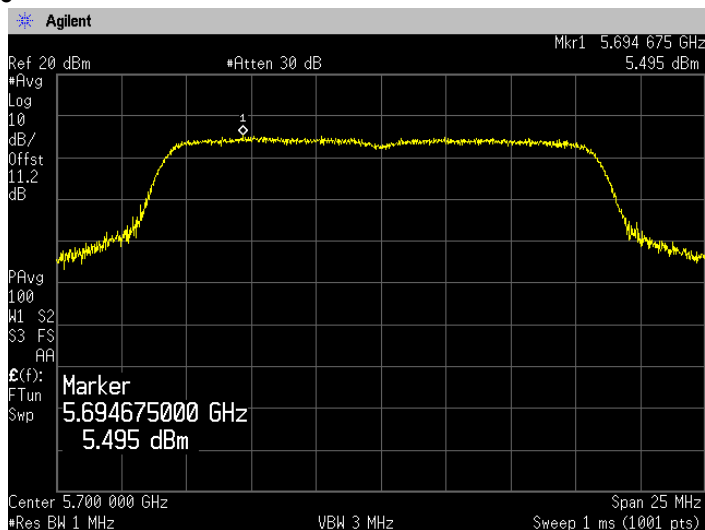



Zacta

(5.8GHz Band)
Channel: 149

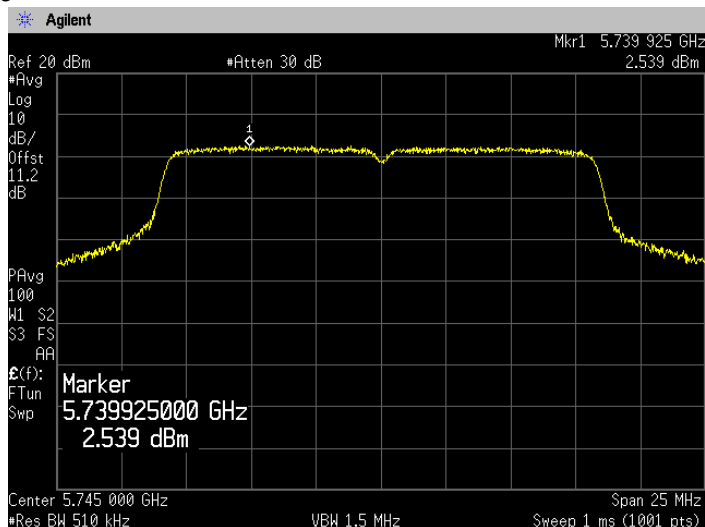

Channel: 157

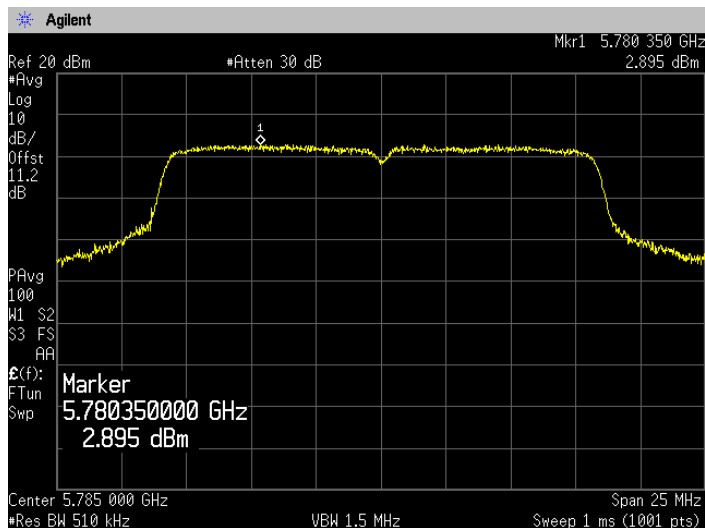

Channel: 165

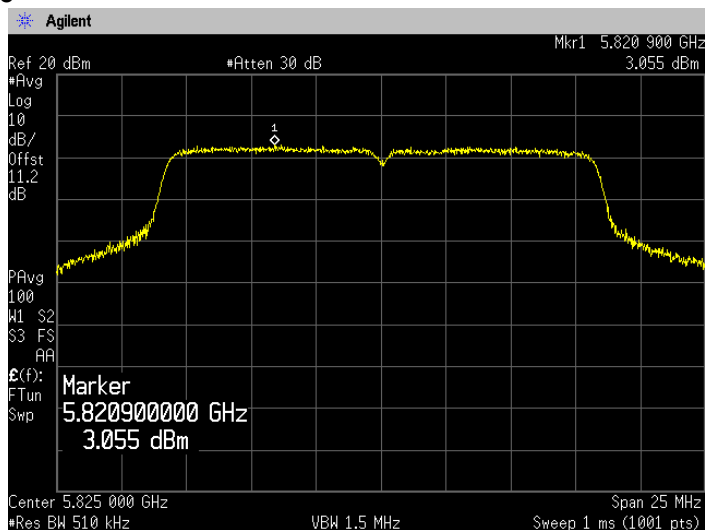



Zacta

[IEEE802.11n (HT20)]
(5.2GHz Band)
Channel: 36

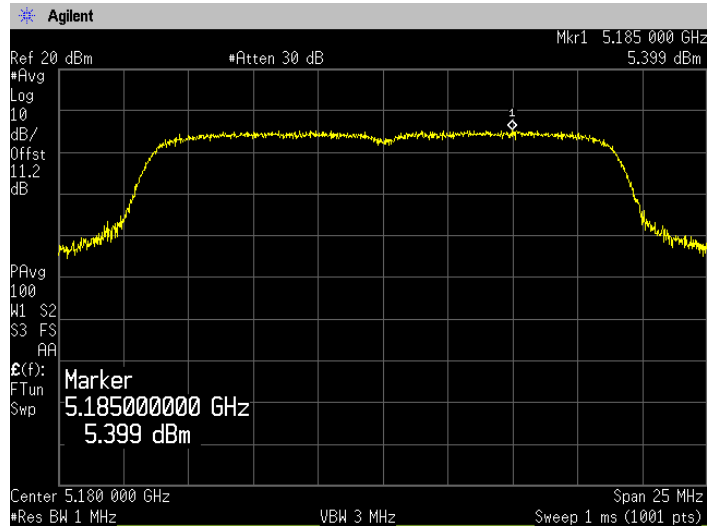

Channel: 40

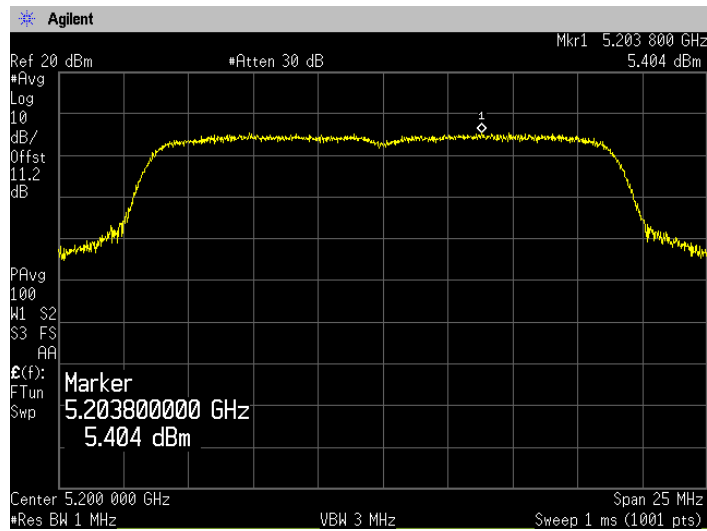

Channel: 48

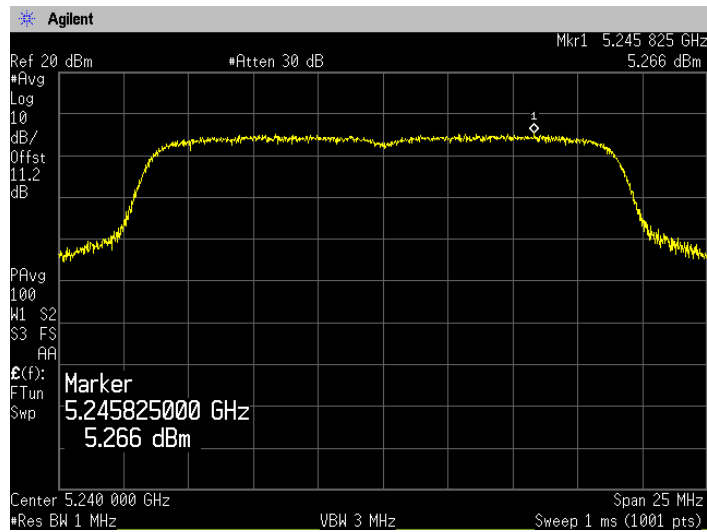



Zacta

(5.3GHz Band)
Channel: 52

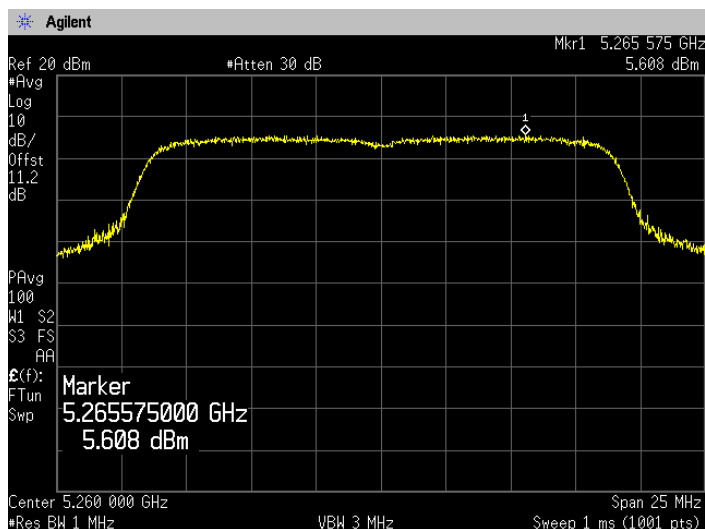

Channel: 56

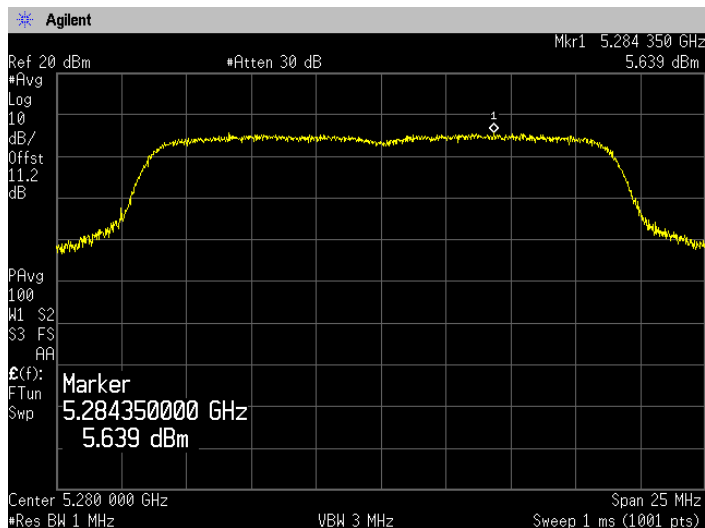

Channel: 64

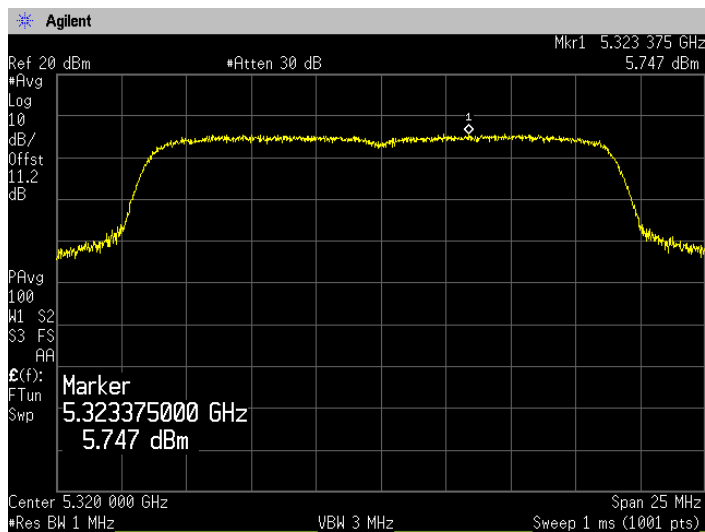



Zacta

(5.6GHz Band)
Channel: 100

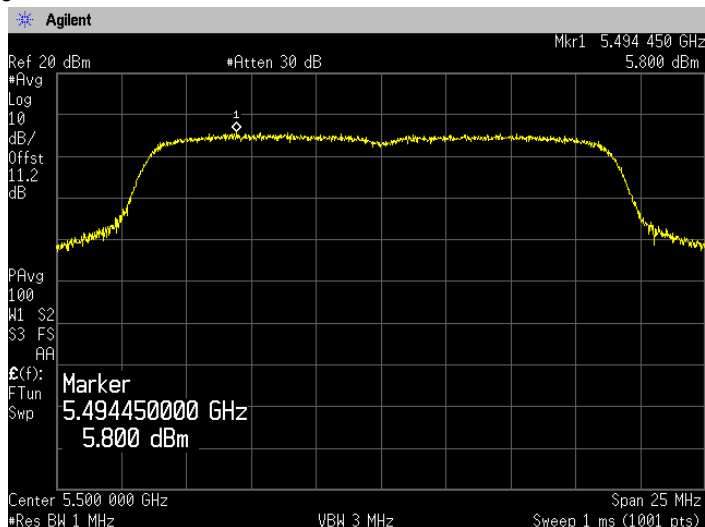

Channel: 120

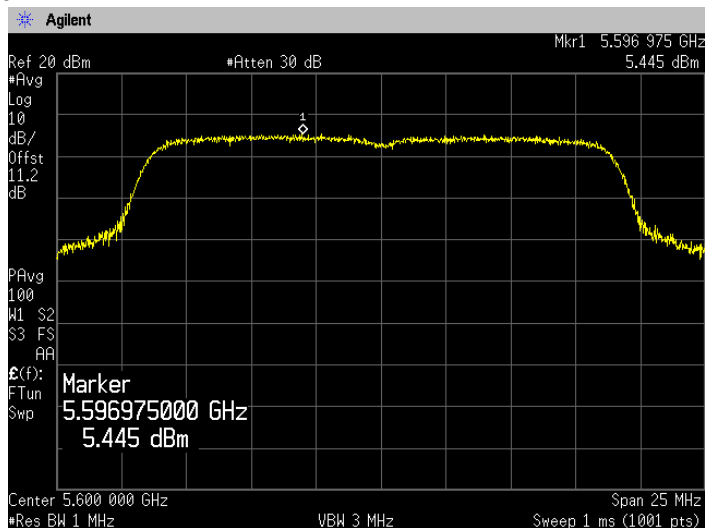

Channel: 140

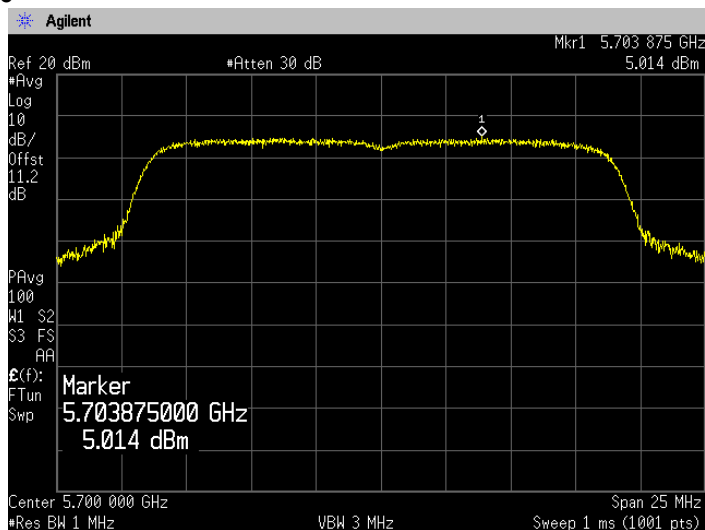



Zacta

**(5.8GHz Band)
Channel: 149**

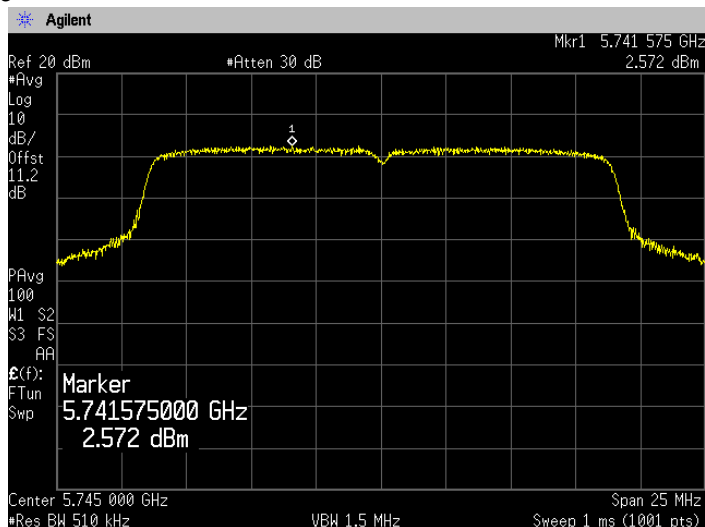

Channel: 157

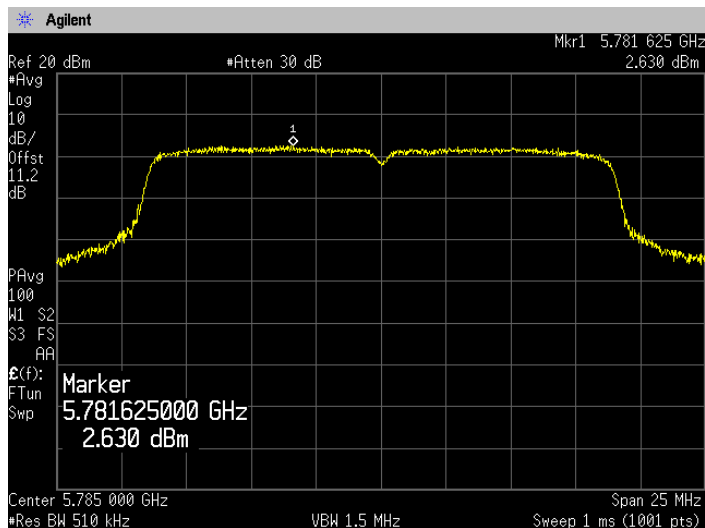

Channel: 165

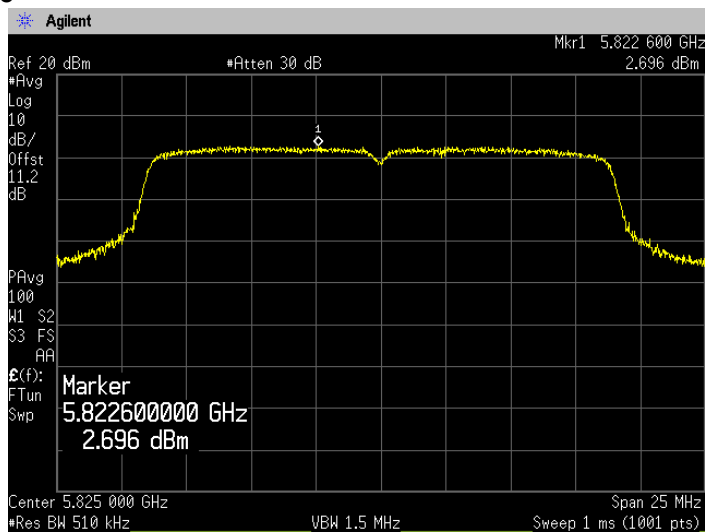

8. Radiated Emissions (Restricted Bands of Operation)

8.1 Measurement procedure

[FCC 15.407(b), 15.205, 15.209, RSS-Gen 8.9, KDB 789033 D02, Section G.4, 5, 6.c)Method AD]

Test was applied by following conditions.

Test method	:	ANSI C63.10
Frequency range	:	30MHz to 40GHz
Test place	:	10m Semi-anechoic chamber No.1
EUT was placed on	:	FRP table / (W)2.0m × (D)1.0m × (H)0.8m Styrofoam table / (W)1.5m × (D)1.0m ×(H)1.5m (above 1GHz)
Antenna distance	:	3m
Test receiver setting	:	Below 1GHz
- Detector	:	Quasi-peak
- Bandwidth	:	120kHz
Spectrum analyzer setting	:	Above 1GHz
- Peak	:	RBW=1MHz, VBW=3MHz, Span=0Hz, Sweep=auto, Detector=Peak Trace mode=Max hold
- Average	:	RBW=1MHz, VBW=3MHz, Span=0Hz, Sweep=auto, Detector=RMS Trace mode=Averaging(300 counts)

Radiated emission measurements are performed at 3m distance with the broadband antenna (Loop antenna, Biconical antenna, Log periodic antenna, Double ridged guide antenna and Broad-band horn antenna). The antenna is positioned both the horizontal and vertical planes of polarization and height is varied 1m to 4m and stopped at height producing the maximum emission. As for the Loop antenna, it is positioned with its plane vertical, and the center of the Loop antenna is 1m above the ground plane.

The EUT is Placed on a turntable, which is 0.8m (below 1GHz) and 1.5m (above 1GHz) above ground plane. The turntable shall be rotated for 360 degrees to determine the position of maximum emission level. The test results represent the worst case emission for each emission with manipulating the EUT, support equipment, interconnecting cables and varying the mode of operation. Sufficient time for the EUT, support equipment, and test equipment are allowed in order for them to warm up to their normal operating condition.

The EUT was set to operate with following conditions.

- 5.2GHz Band, 5.3GHz Band, 5.6GHz Band, 5.8GHz Band

The test mode of EUT is as follows.

- Tx mode, Rx mode

- Test configuration

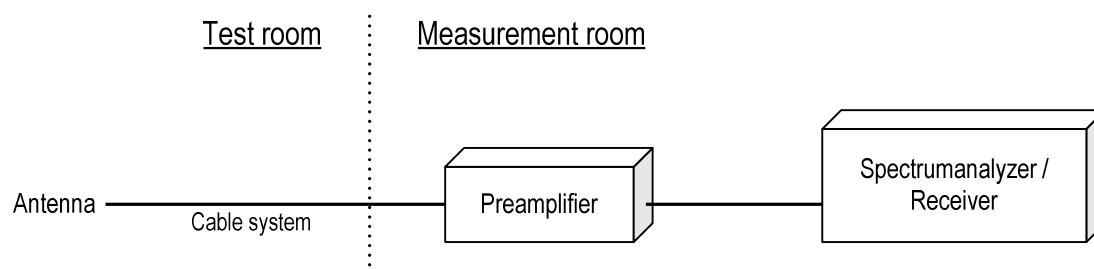

8.2 Calculation method

[150kHz to 25GHz]

Emission level = Reading + (Ant. factor + Cable system loss – Amp. Gain)

Margin = Limit – Emission level

Example:

Detector: Peak

Limit @ 5147.0MHz : 74.0dBuV/m (Peak Limit)

S.A Reading = 40.9dBuV Cable system loss = 16.4dB

Result = 40.9 + 16.4 = 57.3dBuV/m

Margin = 74.0 – 57.3 = 16.7dB

8.3 Limit

- (1) For transmitters operating in the 5.15-5.25GHz band: all emissions outside of the 5.15-5.35GHz band shall not exceed an EIRP of -27dBm/MHz.
- (2) For transmitters operating in the 5.25-5.35GHz band: all emissions outside of the 5.15-5.35GHz band shall not exceed an EIRP of -27dBm/MHz.
- (3) For transmitters operating in the 5.47-5.725GHz band: all emissions outside of the 5.47 5-5.725GHz band shall not exceed an EIRP of -27dBm/MHz.
- (4) For transmitters operating in the 5.725-5.85GHz band: all emissions within the frequency range from the band edge to 10MHz above or below the band edge shall not exceed an EIRP of -17dBm/MHz; for frequencies 10MHz or greater above or below the band edge, emissions shall not exceed an EIRP of -27dBm/MHz.

Frequency [MHz]	Field strength		Distance [m]
	[uV/m]	[dBuV/m]	
0.009-0.490	2400 / F [kHz]	20logE [uV/m]	300
0.490-1.705	24000 / F [kHz]	20logE [uV/m]	30
1.705-30	30	29.5	30
30-88	100	40.0	3
88-216	150	43.5	3
216-960	200	46.0	3
Above 960	500	54.0	3

Note:

1. The lower limit shall apply at the transition frequencies.
2. Emission level [dBuV/m] = 20log Emission [uV/m]
3. As shown in 15.35(b), for frequencies above 1000MHz, the field strength limits are based on average detector, however, the peak field strength of any emission shall not exceed the maximum permitted average limits, specified above by more than 20dB under any condition modulation.



Zacta

8.4 Test data

Date	: January 6, 2016		
Temperature	: 22.8 [°C]		
Humidity	: 48.4 [%]	Test engineer	:
Test place	: 10m Semi-anechoic chamber No.1		<u>Hikaru Shibata</u>
Date	: January 12, 2016		
Temperature	: 21.8 [°C]		
Humidity	: 47.2 [%]	Test engineer	:
Test place	: 10m Semi-anechoic chamber No.1		<u>Hikaru Shibata</u>
Date	: January 13, 2016		
Temperature	: 22.6 [°C]		
Humidity	: 48.9 [%]	Test engineer	:
Test place	: 10m Semi-anechoic chamber No.1		<u>Hikaru Shibata</u>
Date	: January 18,2016		
Temperature	: 20.7 [°C]		
Humidity	: 46.6 [%]	Test engineer	:
Test place	: 10m Semi-anechoic chamber No.1		<u>Hikaru Shibata</u>
Date	: January 19,2016		
Temperature	: 21.2 [°C]		
Humidity	: 47.3 [%]	Test engineer	:
Test place	: 10m Semi-anechoic chamber No.1		<u>Hikaru Shibata</u>
Date	: January 20,2016		
Temperature	: 20.1 [°C]		
Humidity	: 45.9 [%]	Test engineer	:
Test place	: 10m Semi-anechoic chamber No.1		<u>Hikaru Shibata</u>
Date	: January 21,2016		
Temperature	: 20.1 [°C]		
Humidity	: 45.9 [%]	Test engineer	:
Test place	: 10m Semi-anechoic chamber No.1		<u>Hikaru Shibata</u>
Date	: January 22,2016		
Temperature	: 23.2 [°C]		
Humidity	: 49.3 [%]	Test engineer	:
Test place	: 10m Semi-anechoic chamber No.1		<u>Hikaru Shibata</u>
Date	: January 26,2016		
Temperature	: 22.1 [°C]		
Humidity	: 46.7 [%]	Test engineer	:
Test place	: 10m Semi-anechoic chamber No.1		<u>Hikaru Shibata</u>

Note:

Spurious plot data, please refer to Appendix B.



Zacta

[IEEE802.11a]

(5.2GHz Band)

Mode	Channel	Frequency (MHz)	Frequency (MHz)	ANT H/V	Detector PK/AV	Reading (dBμV)	C.F (dB)	Result (dBμV/m)	Limit (dBμV/m)	Margin (dB)
802.11a	36	5180	52.09	V	QP	39.9	-11.8	28.1	40.0	11.9
			125.00	H	QP	44.6	-7.8	36.8	43.5	6.7
			233.50	H	QP	42.2	-3.5	38.7	46.0	7.3
			479.90	H	QP	42.0	-5.2	36.8	46.0	9.2
			720.10	H	QP	43.8	-1.3	42.5	46.0	3.5
			960.20	H	QP	41.2	2.1	43.3	54.0	10.7
	40	5200	47.80	V	QP	47.8	-10.4	37.4	40.0	2.6
			125.00	H	QP	43.7	-7.8	35.9	43.5	7.6
			233.50	H	QP	38.1	-3.5	34.6	46.0	11.4
			479.80	H	QP	43.1	-5.2	37.9	46.0	8.1
			720.10	H	QP	42.4	-1.3	41.1	46.0	4.9
			960.00	H	QP	41.3	2.1	43.4	46.0	2.6
	48	5240	47.80	V	QP	41.3	-10.4	30.9	40.0	9.1
			125.00	H	QP	44.8	-7.8	37.0	43.5	6.5
			235.00	H	QP	41.0	-3.4	37.6	46.0	8.4
			480.00	H	QP	43.4	-5.2	38.2	46.0	7.8
			720.10	H	QP	42.9	-1.3	41.6	46.0	4.4
			960.20	H	QP	42.4	2.1	44.5	54.0	9.5

Mode	Channel	Frequency (MHz)	Frequency (MHz)	ANT H/V	Detector PK/AV	Reading (dBμV)	C.F (dB)	DCF (dB)	Result (dBμV/m)	Limit (dBμV/m)	Margin (dB)
802.11a	36	5180	5127.50	V	PK	39.7	16.4	0.145	56.2	74.0	17.8
			5127.50	V	AV	27.3	16.4	0.145	43.8	54.0	10.2
			10360.00	V	PK	42.6	16.6		59.2	68.2	9.0
	40	5200	10400.00	V	PK	42.1	16.7		58.8	68.2	9.4
	48	5240	10480.00	V	PK	43.0	16.9		59.9	68.2	8.3



Zacta

(5.3GHz Band)

Mode	Channel	Frequency (MHz)	Frequency (MHz)	ANT H/V	Detector PK/AV	Reading (dBµV)	C.F (dB)	Result (dBµV/m)	Limit (dBµV/m)	Margin (dB)
802.11a	52	5260	55.10	V	QP	40.5	-12.7	27.8	40.0	12.2
			125.00	H	QP	46.2	-7.8	38.4	43.5	5.1
			233.50	H	QP	40.3	-3.5	36.8	46.0	9.2
			480.00	H	QP	46.9	-5.2	41.7	46.0	4.3
			720.10	H	QP	43.2	-1.3	41.9	46.0	4.1
			960.10	H	QP	42.2	2.1	44.3	54.0	9.7
	56	5280	54.90	V	QP	40.6	-12.6	28.0	40.0	12.0
			125.00	H	QP	45.2	-7.8	37.4	43.5	6.1
			233.50	H	QP	41.1	-3.5	37.6	46.0	8.4
			480.00	H	QP	45.8	-5.2	40.6	46.0	5.4
			720.10	H	QP	44.2	-1.3	42.9	46.0	3.1
			960.20	H	QP	41.6	2.1	43.7	46.0	2.3
	64	5320	55.40	V	QP	41.3	-12.8	28.5	40.0	11.5
			125.00	H	QP	45.1	-7.8	37.3	43.5	6.2
			235.00	H	QP	41.1	-3.4	37.7	46.0	8.3
			480.00	H	QP	45.8	-5.2	40.6	46.0	5.4
			720.10	H	QP	43.8	-1.3	42.5	46.0	3.5
			960.20	H	QP	41.7	2.1	43.8	54.0	10.2

Mode	Channel	Frequency (MHz)	Frequency (MHz)	ANT H/V	Detector PK/AV	Reading (dBµV)	C.F (dB)	DCF (dB)	Result (dBµV/m)	Limit (dBµV/m)	Margin (dB)
802.11a	52	5260	10520.00	V	PK	42.3	16.9		59.2	68.2	9.0
	56	5280	10560.00	V	PK	43.1	16.8		59.9	68.2	8.3
	64	5320	5351.50	V	PK	39.2	16.2	0.138	55.5	74.0	18.5
			5351.50	V	AV	27.8	16.2	0.138	44.1	54.0	9.9
			10640.00	V	PK	44.0	16.9		60.9	74.0	13.1
			10640.00	V	AV	29.0	16.9		45.9	54.0	8.1

(5.6GHz Band)

Mode	Channel	Frequency (MHz)	Frequency (MHz)	ANT H/V	Detector PK/AV	Reading (dBμV)	C.F (dB)	Result (dBμV/m)	Limit (dBμV/m)	Margin (dB)
802.11a	100	5500	53.90	V	QP	41.1	-12.4	28.7	40.0	11.3
			125.00	H	QP	46.4	-7.8	38.6	43.5	4.9
			235.40	H	QP	40.1	-3.4	36.7	46.0	9.3
			480.00	H	QP	48.1	-5.2	42.9	46.0	3.1
			720.10	H	QP	43.7	-1.3	42.4	46.0	3.6
			930.20	H	QP	44.6	2.1	46.7	54.0	7.3
	120	5600	47.60	V	QP	39.8	-10.4	29.4	40.0	10.6
			125.00	H	QP	45.8	-7.8	38.0	43.5	5.5
			235.10	H	QP	40.2	-3.4	36.8	46.0	9.2
			480.00	H	QP	45.3	-5.2	40.1	46.0	5.9
			720.10	H	QP	43.3	-1.3	42.0	46.0	4.0
			960.20	H	QP	44.1	2.1	46.2	46.0	-0.2
	140	5700	47.80	V	QP	40.2	-12.8	27.4	40.0	12.6
			125.00	H	QP	45.8	-7.8	38.0	43.5	5.5
			233.50	H	QP	42.2	-3.4	38.8	46.0	7.2
			480.00	H	QP	46.2	-5.2	41.0	46.0	5.0
			720.00	H	QP	44.1	-1.3	42.8	46.0	3.2
			960.20	H	QP	42.8	2.1	44.9	54.0	9.1

Mode	Channel	Frequency (MHz)	Frequency (MHz)	ANT H/V	Detector PK/AV	Reading (dBμV)	C.F (dB)	DCF (dB)	Result (dBμV/m)	Limit (dBμV/m)	Margin (dB)
802.11a	100	5500	5447.35	H	PK	41.8	16.3	0.145	58.2	74.0	15.8
			5447.35	H	AV	30.0	16.3	0.145	46.4	54.0	7.6
			5447.35	V	PK	42.8	16.3	0.145	59.2	74.0	14.8
			5447.35	V	AV	32.1	16.3	0.145	48.5	54.0	5.5
			5468.90	H	PK	40.7	16.3		57.0	68.2	11.2
			5468.90	V	PK	40.4	16.3		56.7	68.2	11.5
			11000.00	V	PK	43.2	17.0		60.2	74.0	13.8
	120	5600	11000.00	V	AV	34.5	17.0		51.5	54.0	2.5
			11200.00	H	PK	42.1	17.1		59.2	74.0	14.8
			11200.00	H	AV	34.0	17.1		51.1	54.0	2.9
			11200.00	V	PK	42.9	17.1		60.0	74.0	14.0
			11200.00	V	AV	28.2	17.1		45.3	54.0	8.7
			140	5700	5725.70	H	PK	45.3	17.0		62.3
	5725.70	V			PK	45.9	17.0		62.9	68.2	5.3
	11400.00	V			PK	42.7	17.4		60.1	74.0	13.9
11400.00	V	AV			34.2	17.4		51.6	54.0	2.4	

(5.8GHz Band)

Mode	Channel	Frequency (MHz)	Frequency (MHz)	ANT H/V	Detector PK/AV	Reading (dBµV)	C.F (dB)	Result (dBµV/m)	Limit (dBµV/m)	Margin (dB)
802.11a	149	5745	53.70	V	QP	40.3	-12.3	28.0	40.0	12.0
			125.00	H	QP	46.9	-7.8	39.1	43.5	4.4
			233.70	H	QP	40.1	-3.5	36.6	46.0	9.4
			480.00	H	QP	47.1	-5.2	41.9	46.0	4.1
			720.00	H	QP	42.8	2.1	44.9	46.0	1.1
			960.00	H	QP	42.0	2.1	44.1	46.0	1.9
	157	5785	53.10	V	QP	40.1	-12.4	27.7	40.0	12.3
			125.00	H	QP	47.5	-7.8	39.7	43.5	3.8
			235.10	H	QP	40.3	-3.4	36.9	46.0	9.1
			480.00	H	QP	47.1	-5.2	41.9	46.0	4.1
			720.10	H	QP	43.3	-1.3	42.0	46.0	4.0
			960.20	H	QP	42.2	2.1	44.3	46.0	1.7
	165	5825	54.10	V	QP	41.8	-12.4	29.4	40.0	10.6
			125.00	H	QP	48.2	-7.8	40.4	43.5	3.1
			235.40	H	QP	40.3	-3.4	36.9	46.0	9.1
			480.00	H	QP	48.2	-5.2	43.0	46.0	3.0
			720.00	H	QP	43.5	-1.3	42.2	46.0	3.8
			960.20	H	QP	41.2	2.1	43.3	54.0	10.7

Mode	Channel	Frequency (MHz)	Frequency (MHz)	ANT H/V	Detector PK/AV	Reading (dBµV)	C.F (dB)	DCF (dB)	Result (dBµV/m)	Limit (dBµV/m)	Margin (dB)
802.11a	149	5745	5714.70	H	PK	46.4	16.9		63.3	68.2	4.9
			5714.70	V	PK	46.0	16.9		62.9	68.2	5.3
			5724.60	H	PK	56.5	17.0		73.5	78.2	4.7
			5725.00	V	PK	55.1	17.0		72.1	78.2	6.1
			11490.00	H	PK	42.8	17.6		60.4	74.0	13.6
			11490.00	H	AV	34.5	17.6		52.1	54.0	1.9
			11490.00	V	PK	43.1	17.6		60.7	74.0	13.3
			11490.00	V	AV	34.0	17.6		51.6	54.0	2.4
	157	5785	11570.00	H	PK	44.8	17.7		62.5	74.0	11.5
			11570.00	H	AV	33.6	17.7		51.3	54.0	2.7
			11570.00	V	PK	44.1	17.7		61.8	74.0	12.2
			11570.00	V	AV	33.2	17.7		50.9	54.0	3.1
	165	5825	5850.60	H	PK	49.9	17.3		67.2	78.2	11.0
			5850.90	V	PK	49.1	17.3		66.4	78.2	11.8
			5860.50	H	PK	45.1	17.3		62.4	68.2	5.8
			5861.00	V	PK	42.1	17.3		59.4	68.2	8.8
			11650.00	H	PK	44.6	17.9		62.5	74.0	11.5
			11650.00	V	AV	34.7	17.9		52.6	54.0	1.4
			11650.00	H	PK	44.2	17.9		62.1	74.0	11.9
			11650.00	V	AV	34.2	17.9		52.1	54.0	1.9

Note:

- Emission Level (Margin) = Limit - [Reading + C.F (Antenna + Cable - Amp)]
- Emission Level (Margin) = Limit - [Reading + DCF + C.F (Antenna + Cable - Amp)] (Detector: AV, above 1GHz)



Zacta

[IEEE802.11n (HT20)]
(5.2GHz Band)

Mode	Channel	Frequency (MHz)	Frequency (MHz)	ANT H/V	Detector PK/AV	Reading (dBμV)	C.F (dB)	Result (dBμV/m)	Limit (dBμV/m)	Margin (dB)
802.11n (20MHz)	36	5180	47.80	V	QP	42.5	-10.4	32.1	40.0	7.9
			85.30	V	QP	46.2	-14.6	31.6	40.0	8.4
			125.00	H	QP	45.9	-7.8	38.1	43.5	5.4
			240.00	H	QP	41.1	-3.4	37.7	46.0	8.3
			480.00	H	QP	45.4	-5.2	40.2	46.0	5.8
			720.10	H	QP	45.6	-1.3	44.3	46.0	1.7
			960.20	H	QP	45.9	2.1	48.0	54.0	6.0
	40	5200	47.80	V	QP	42.7	-10.4	32.3	40.0	7.7
			85.30	V	QP	45.4	-14.6	30.8	40.0	9.2
			125.00	H	QP	45.9	-7.8	38.1	43.5	5.4
			174.80	H	QP	41.3	-5.0	36.3	43.5	7.2
			240.00	H	QP	39.8	-3.4	36.4	46.0	9.6
			480.00	H	QP	44.7	-5.2	39.5	46.0	6.5
			720.10	H	QP	45.5	-1.3	44.2	46.0	1.8
	48	5240	960.00	H	QP	48.2	2.1	50.3	54.0	3.7
			47.80	V	QP	42.6	-10.4	32.2	40.0	7.8
			86.10	V	QP	46.1	-14.5	31.6	40.0	8.4
			125.00	H	QP	46.1	-7.8	38.3	43.5	5.2
			174.70	H	QP	43.5	-5.0	38.5	43.5	5.0
			234.70	H	QP	40.5	-3.4	37.1	46.0	8.9
			480.00	H	QP	44.4	-5.2	39.2	46.0	6.8
	720.10	H	QP	45.5	-1.3	44.2	46.0	1.8		
	960.20	H	QP	48.9	2.1	51.0	54.0	3.0		

Mode	Channel	Frequency (MHz)	Frequency (MHz)	ANT H/V	Detector PK/AV	Reading (dBμV)	C.F (dB)	DCF (dB)	Result (dBμV/m)	Limit (dBμV/m)	Margin (dB)
802.11n (20MHz)	36	5180	5127.50	V	PK	39.7	16.4	0.148	56.2	74.0	17.8
			5127.50	V	AV	27.3	16.4	0.148	43.8	54.0	10.2
			10360.00	V	PK	42.6	16.6		59.2	68.2	9.0
	40	5200	10400.00	V	PK	42.1	16.7		58.8	68.2	9.4
	48	5240	10480.00	V	PK	43.0	16.9		59.9	68.2	8.3



Zacta

(5.3GHz Band)

Mode	Channel	Frequency (MHz)	Frequency (MHz)	ANT H/V	Detector PK/AV	Reading (dBμV)	C.F (dB)	Result (dBμV/m)	Limit (dBμV/m)	Margin (dB)
802.11n (20MHz)	52	5260	47.80	V	QP	42.9	-10.4	32.5	40.0	7.5
			86.00	V	QP	46.4	-14.5	31.9	40.0	8.1
			125.00	H	QP	45.4	-7.8	37.6	43.5	5.9
			176.00	H	QP	43.1	-5.0	38.1	43.5	5.4
			240.00	H	QP	42.1	-3.4	38.7	46.0	7.3
			480.00	H	QP	42.1	-5.2	36.9	46.0	9.1
			720.10	H	QP	43.9	-1.3	42.6	46.0	3.4
			960.20	H	QP	45.1	2.1	47.2	54.0	6.8
	56	5280	47.80	V	QP	42.2	-10.4	31.8	40.0	8.2
			86.70	V	QP	45.7	-14.3	31.4	40.0	8.6
			125.00	H	QP	45.4	-7.8	37.6	43.5	5.9
			174.80	H	QP	42.5	-5.0	37.5	43.5	6.0
			236.10	H	QP	43.9	-3.4	40.5	46.0	5.5
			480.00	H	QP	43.6	-5.2	38.4	46.0	7.6
			720.10	H	QP	45.1	-1.3	43.8	46.0	2.2
			960.20	H	QP	49.5	2.1	51.6	54.0	2.4
	64	5320	47.80	V	QP	42.5	-10.4	32.1	40.0	7.9
			86.10	V	QP	45.8	-14.5	31.3	43.5	12.2
			125.00	H	QP	43.1	-7.8	35.3	46.0	10.7
			174.80	H	QP	37.9	-5.0	32.9	47.0	14.1
			240.00	H	QP	42.1	-3.4	38.7	48.0	9.3
			480.00	H	QP	44.1	-5.2	38.9	46.0	7.1
			720.10	H	QP	44.4	-1.3	43.1	46.0	2.9
			960.20	H	QP	48.9	2.1	51.0	54.0	3.0

Mode	Channel	Frequency (MHz)	Frequency (MHz)	ANT H/V	Detector PK/AV	Reading (dBμV)	C.F (dB)	DCF (dB)	Result (dBμV/m)	Limit (dBμV/m)	Margin (dB)
802.11n (20MHz)	52	5260	10520.00	V	PK	43.5	16.9		60.4	68.2	7.8
	56	5280	10560.00	V	PK	42.9	16.8		59.7	68.2	8.5
	64	5320	5372.40	H	PK	41.8	16.2	0.161	58.2	74.0	15.8
			5372.40	H	AV	34.3	16.2	0.161	50.7	54.0	3.3
			5374.40	V	PK	42.7	16.2	0.161	59.1	74.0	14.9
			5374.40	V	AV	34.0	16.2	0.161	50.4	54.0	3.6
			10640.00	V	PK	43.9	16.9		60.8	74.0	13.2
			10640.00	V	AV	34.8	16.9		51.7	54.0	2.3



Zacta

(5.6GHz Band)

Mode	Channel	Frequency (MHz)	Frequency (MHz)	ANT H/V	Detector PK/AV	Reading (dBµV)	C.F (dB)	Result (dBµV/m)	Limit (dBµV/m)	Margin (dB)
802.11n (20MHz)	100	5500	47.80	V	QP	42.4	-10.4	32.0	40.0	8.0
			86.00	V	QP	45.9	-14.5	31.4	40.0	8.6
			125.00	H	QP	43.8	-7.8	36.0	43.5	7.5
			175.20	H	QP	41.2	-5.0	36.2	43.5	7.3
			240.00	H	QP	41.6	-3.4	38.2	46.0	7.8
			480.00	H	QP	44.1	-5.2	38.9	46.0	7.1
			720.10	H	QP	44.1	-1.3	42.8	46.0	3.2
			960.20	H	QP	49.4	2.1	51.5	54.0	2.5
	120	5600	47.80	V	QP	41.8	-10.4	31.4	40.0	8.6
			85.40	V	QP	45.2	-14.6	30.6	40.0	9.4
			125.00	H	QP	45.6	-7.8	37.8	43.5	5.7
			174.60	H	QP	41.9	-5.0	36.9	43.5	6.6
			240.00	H	QP	41.9	-3.4	38.5	46.0	7.5
			480.00	H	QP	45.1	-5.2	39.9	46.0	6.1
			720.10	H	QP	44.6	-1.3	43.3	46.0	2.7
			960.20	H	QP	49.4	2.1	51.5	54.0	2.5
	140	5700	47.80	V	QP	42.1	-10.4	31.7	40.0	8.3
			85.30	V	QP	46.2	-14.6	31.6	40.0	8.4
			125.00	H	QP	44.9	-7.8	37.1	43.5	6.4
			174.80	H	QP	41.2	-5.0	36.2	43.5	7.3
			240.00	H	QP	41.4	-3.4	38.0	46.0	8.0
			480.00	H	QP	45.3	-5.2	40.1	46.0	5.9
			720.10	H	QP	43.9	-1.3	42.6	46.0	3.4
			960.20	H	QP	48.8	2.1	50.9	54.0	3.1

Mode	Channel	Frequency (MHz)	Frequency (MHz)	ANT H/V	Detector PK/AV	Reading (dBµV)	C.F (dB)	DCF (dB)	Result (dBµV/m)	Limit (dBµV/m)	Margin (dB)		
802.11n (20MHz)	100	5500	5447.10	H	PK	45.0	16.3	0.148	61.4	74.0	12.6		
			5447.10	H	AV	35.0	16.3	0.148	51.4	54.0	2.6		
			5447.00	V	PK	41.2	16.3	0.148	57.6	74.0	16.4		
			5447.00	V	AV	33.3	16.3	0.148	49.7	54.0	4.3		
			5468.10	H	PK	49.2	16.3		65.5	68.2	2.7		
			5467.70	V	PK	46.5	16.3		62.8	68.2	5.4		
			11000.00	H	PK	43.1	17.0		60.1	74.0	13.9		
			11000.00	H	AV	34.4	17.0		51.4	54.0	2.6		
	120	5600	11000.00	V	PK	43.8	17.0		60.8	74.0	13.2		
			11000.00	V	AV	34.6	17.0		51.6	54.0	2.4		
			11200.00	H	PK	43.1	17.1		60.2	74.0	13.8		
			11200.00	H	AV	33.9	17.1		51.0	54.0	3.0		
			11200.00	V	PK	42.5	17.1		59.6	74.0	14.4		
			11200.00	V	AV	33.6	17.1		50.7	54.0	3.3		
			140	5700	11400.00	H	PK	42.7	17.4		60.1	74.0	13.9
					11400.00	H	AV	33.1	17.4		50.5	54.0	3.5
11400.00	V	PK			42.3	17.4		59.7	74.0	14.3			
11400.00	V	AV			34.1	17.4		51.5	54.0	2.5			



Zacta

(5.8GHz Band)

Mode	Channel	Frequency (MHz)	Frequency (MHz)	ANT H/V	Detector PK/AV	Reading (dBµV)	C.F (dB)	Result (dBµV/m)	Limit (dBµV/m)	Margin (dB)
802.11n (20MHz)	149	5745	47.80	V	QP	42.2	-10.4	31.8	40.0	8.2
			86.60	V	QP	44.6	-14.3	30.3	40.0	9.7
			125.00	H	QP	47.9	-7.8	40.1	43.5	3.4
			173.40	H	QP	42.5	-5.1	37.4	43.5	6.1
			236.10	H	QP	42.9	-3.4	39.5	46.0	6.5
			480.00	H	QP	37.6	-5.2	32.4	46.0	13.6
			720.10	H	QP	42.6	-1.3	41.3	46.0	4.7
			960.20	H	QP	48.9	2.1	51.0	54.0	3.0
	157	5785	47.60	V	QP	43.2	-10.4	32.8	40.0	7.2
			86.60	V	QP	43.9	-14.3	29.6	40.0	10.4
			125.00	H	QP	46.8	-7.8	39.0	43.5	4.5
			173.60	H	QP	41.9	-5.1	36.8	43.5	6.7
			236.60	H	QP	42.2	-3.4	38.8	46.0	7.2
			480.00	H	QP	40.1	-5.2	34.9	46.0	11.1
			720.00	H	QP	42.2	-1.3	40.9	46.0	5.1
			960.20	H	QP	47.1	2.1	49.2	54.0	4.8
	165	5825	47.80	V	QP	42.9	-10.4	32.5	40.0	7.5
			86.60	V	QP	43.6	-14.3	29.3	40.0	10.7
			125.00	H	QP	46.8	-7.8	39.0	43.5	4.5
			173.60	H	QP	42.3	-5.1	37.2	43.5	6.3
			236.00	H	QP	41.8	-3.4	38.4	46.0	7.6
			480.00	H	QP	40.8	-5.2	35.6	46.0	10.4
			720.00	H	QP	42.5	-1.3	41.2	46.0	4.8
			960.20	H	QP	47.0	2.1	49.1	54.0	4.9

Mode	Channel	Frequency (MHz)	Frequency (MHz)	ANT H/V	Detector PK/AV	Reading (dBµV)	C.F (dB)	DCF (dB)	Result (dBµV/m)	Limit (dBµV/m)	Margin (dB)
802.11n (20MHz)	149	5745	5714.70	H	PK	45.2	16.9		62.1	68.2	6.1
			5714.90	V	PK	46.8	16.9		63.7	68.2	4.5
			5724.60	H	PK	52.3	17.0		69.3	78.2	8.9
			5724.60	V	PK	55.3	17.0		72.3	78.2	5.9
			11490.00	H	PK	43.3	17.6		60.9	74.0	13.1
			11490.00	H	AV	34.1	17.6		51.7	54.0	2.3
			11490.00	V	PK	42.9	17.6		60.5	74.0	13.5
			11490.00	V	AV	33.5	17.6		51.1	54.0	2.9
	157	5785	11570.00	H	PK	44.3	17.7		62.0	74.0	12.0
			11570.00	H	AV	33.4	17.7		51.1	54.0	2.9
			11570.00	V	PK	43.7	17.7		61.4	74.0	12.6
			11570.00	V	AV	33.0	17.7		50.7	54.0	3.3
	165	5825	5850.00	H	PK	51.2	17.3		68.5	78.2	9.7
			5850.10	V	PK	50.0	17.3		67.3	78.2	10.9
			5860.40	H	PK	43.7	17.3		61.0	68.2	7.2
			5860.50	V	PK	45.3	17.3		62.6	68.2	5.6
			11650.00	H	PK	44.7	17.9		62.6	74.0	11.4
			11650.00	V	AV	34.3	17.9		52.2	54.0	1.8
			11650.00	H	PK	43.9	17.9		61.8	74.0	12.2
			11650.00	V	AV	33.4	17.9		51.3	54.0	2.7

Note:

1. Emission Level (Margin) = Limit - [Reading + C.F (Antenna + Cable – Amp)]
2. Emission Level (Margin) = Limit - [Reading + DCF + C.F (Antenna + Cable – Amp)] (Detector: AV, above 1GHz)



Zacta

**[Receive mode]
(5.2GHz Band)**

Mode	Channel	Frequency (MHz)	Frequency (MHz)	ANT H/V	Detector PK/AV	Reading (dBµV)	C.F (dB)	Result (dBµV/m)	Limit (dBµV/m)	Margin (dB)
Recive	36	5180	53.90	V	QP	40.1	-12.4	27.7	40.0	12.3
			125.00	H	QP	45.1	-7.8	37.3	43.5	6.2
			236.00	H	QP	41.8	-3.4	38.4	46.0	7.6
			370.00	H	QP	42.3	-7.6	34.7	46.0	11.3
			480.00	H	QP	42.3	-5.2	37.1	46.0	8.9
			720.10	H	QP	45.6	-1.3	44.3	46.0	1.7
	960.20	H	QP	47.0	2.1	49.1	54.0	4.9		
	40	5200	53.90	V	QP	41.1	-12.4	28.7	40.0	11.3
			125.00	H	QP	44.6	-7.8	36.8	43.5	6.7
			236.00	H	QP	42.2	-3.4	38.8	46.0	7.2
			370.00	H	QP	46.2	-7.6	38.6	46.0	7.4
			480.00	H	QP	41.7	-5.2	36.5	46.0	9.5
			720.10	H	QP	42.0	-1.3	40.7	46.0	5.3
	960.20	H	QP	45.3	2.1	47.4	54.0	6.6		
	48	5240	54.00	V	QP	41.8	-12.4	29.4	40.0	10.6
			125.00	H	QP	43.5	-7.8	35.7	43.5	7.8
			238.00	H	QP	43.2	-3.4	39.8	46.0	6.2
			368.00	H	QP	44.8	-7.7	37.1	46.0	8.9
480.00			H	QP	42.2	-5.2	37.0	46.0	9.0	
720.10			H	QP	43.2	-1.3	41.9	46.0	4.1	
960.20	H	QP	45.3	2.1	47.4	54.0	6.6			

(5.3GHz Band)

Mode	Channel	Frequency (MHz)	Frequency (MHz)	ANT H/V	Detector PK/AV	Reading (dBµV)	C.F (dB)	Result (dBµV/m)	Limit (dBµV/m)	Margin (dB)
Recive	52	5260	54.70	V	QP	45.3	-12.6	32.7	40.0	7.3
			125.00	H	QP	46.7	-7.8	38.9	43.5	4.6
			244.00	H	QP	43.6	-3.3	40.3	46.0	5.7
			370.10	H	QP	47.7	-7.6	40.1	46.0	5.9
			480.00	H	QP	38.9	-5.2	33.7	46.0	12.3
			720.10	H	QP	41.7	-1.3	40.4	46.0	5.6
	960.20	H	QP	44.3	2.1	46.4	54.0	7.6		
	56	5280	54.60	V	QP	44.9	-12.6	32.3	40.0	7.7
			125.00	H	QP	46.2	-7.8	38.4	43.5	5.1
			240.00	H	QP	43.6	-3.4	40.2	46.0	5.8
			370.00	H	QP	46.7	-7.6	39.1	46.0	6.9
			480.00	H	QP	45.3	-5.2	40.1	46.0	5.9
			720.10	H	QP	42.3	-1.3	41.0	46.0	5.0
	960.20	H	QP	45.2	2.1	47.3	54.0	6.7		
	64	5320	54.70	V	QP	44.3	-12.6	31.7	40.0	8.3
			125.00	H	QP	46.4	-7.8	38.6	43.5	4.9
			240.00	H	QP	44.8	-3.4	41.4	46.0	4.6
			370.00	H	QP	46.7	-7.6	39.1	48.0	8.9
480.00			H	QP	45.2	-5.2	40.0	46.0	6.0	
720.10			H	QP	42.6	-1.3	41.3	46.0	4.7	
960.20	H	QP	44.7	2.1	46.8	54.0	7.2			



Zacta

(5.6GHz Band)

Mode	Channel	Frequency (MHz)	Frequency (MHz)	ANT H/V	Detector PK/AV	Reading (dBµV)	C.F (dB)	Result (dBµV/m)	Limit (dBµV/m)	Margin (dB)
Recive	100	5500	54.70	V	QP	44.9	-12.6	32.3	40.0	7.7
			125.00	H	QP	48.2	-7.8	40.4	43.5	3.1
			244.00	H	QP	43.6	-3.3	40.3	46.0	5.7
			368.10	H	QP	46.8	-7.7	39.1	46.0	6.9
			480.00	H	QP	40.0	-5.2	34.8	46.0	11.2
			720.10	H	QP	42.1	-1.3	40.8	46.0	5.2
			960.20	H	QP	43.7	2.1	45.8	54.0	8.2
	130	5600	54.70	V	QP	44.4	-12.6	31.8	40.0	8.2
			125.00	H	QP	47.8	-7.8	40.0	43.5	3.5
			240.00	H	QP	43.7	-3.4	40.3	46.0	5.7
			360.00	H	QP	46.5	-8.0	38.5	46.0	7.5
			480.00	H	QP	41.1	-5.2	35.9	46.0	10.1
			720.10	H	QP	42.4	-1.3	41.1	46.0	4.9
			960.20	H	QP	43.5	2.1	45.6	54.0	8.4
	140	5700	54.70	V	QP	43.1	-12.6	30.5	40.0	9.5
			125.00	H	QP	47.8	-7.8	40.0	43.5	3.5
			240.00	H	QP	43.2	-3.4	39.8	46.0	6.2
			360.00	H	QP	45.5	-8.0	37.5	46.0	8.5
			480.00	H	QP	42.0	-5.2	36.8	46.0	9.2
			720.10	H	QP	42.4	-1.3	41.1	46.0	4.9
			960.20	H	QP	43.8	2.1	45.9	54.0	8.1

(5.8GHz Band)

Mode	Channel	Frequency (MHz)	Frequency (MHz)	ANT H/V	Detector PK/AV	Reading (dBµV)	C.F (dB)	Result (dBµV/m)	Limit (dBµV/m)	Margin (dB)
Recive	149	5745	54.80	V	QP	43.0	-12.6	30.4	40.0	9.6
			125.00	H	QP	48.7	-7.8	40.9	43.5	2.6
			240.00	H	QP	43.2	-3.4	39.8	46.0	6.2
			370.50	H	QP	46.4	-7.6	38.8	46.0	7.2
			480.00	H	QP	41.2	-5.2	36.0	46.0	10.0
			720.10	H	QP	41.4	-1.3	40.1	46.0	5.9
			960.20	H	QP	44.4	2.1	46.5	54.0	7.5
	157	5785	54.70	V	QP	42.7	-12.6	30.1	40.0	9.9
			125.00	H	QP	47.8	-7.8	40.0	43.5	3.5
			240.00	H	QP	42.6	-3.4	39.2	46.0	6.8
			370.50	H	QP	47.1	-7.6	39.5	46.0	6.5
			480.00	H	QP	42.2	-5.2	37.0	46.0	9.0
			720.10	H	QP	42.3	-1.3	41.0	46.0	5.0
			960.20	H	QP	43.7	2.1	45.8	54.0	8.2
	165	5825	54.70	V	QP	43.1	-12.6	30.5	40.0	9.5
			125.00	H	QP	46.6	-7.8	38.8	43.5	4.7
			240.00	H	QP	43.0	-3.4	39.6	46.0	6.4
			370.50	H	QP	47.4	-7.6	39.8	46.0	6.2
			480.00	H	QP	42.8	-5.2	37.6	46.0	8.4
			720.10	H	QP	43.2	-1.3	41.9	46.0	4.1
			960.20	H	QP	43.4	2.1	45.5	54.0	8.5

9. Frequency Stability

9.1 Measurement procedure [FCC 15.407(g), RSS-Gen 6.11]

The EUT was placed of an inside of an constant temperature chamber as the temperature in the chamber was varied between -30°C and $+60^{\circ}\text{C}$. The temperature was incremented by 10°C intervals and the unit was allowed to stabilize at each measurement. The center frequency of the transmitting channel was evaluated at each temperature and the frequency deviation from the channels center frequency was recorded.

The EUT was set to operate with following conditions.

- 5.2GHz Band, 5.3GHz Band, 5.6GHz Band, 5.8GHz Band

The test mode of EUT is as follows.

- Tx mode
- Test configuration

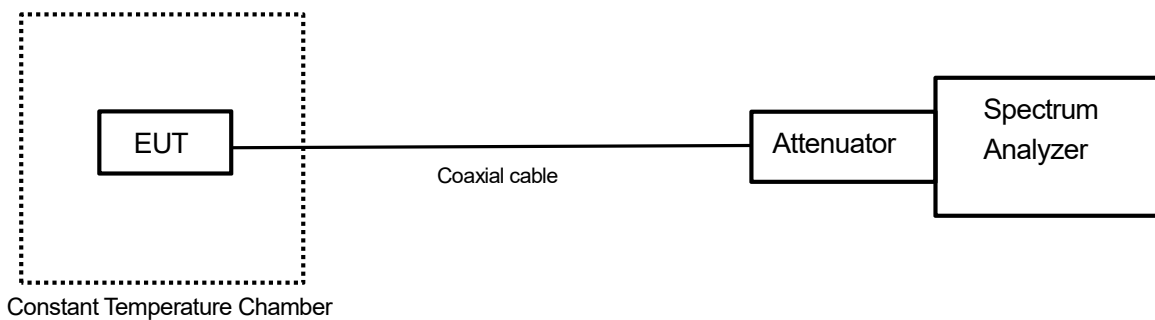

9.2 Limit

Manufacturers of U-NII devices are responsible for ensuring frequency stability such that an emission is maintained within the band of operation under all conditions of normal operation as specified.

9.3 Measurement result

Date : February 10, 2016
 Temperature : 21.1 [°C]
 Humidity : 46.9 [%]
 Test place : Shielded room No.4

Test engineer : Kazunori Saito

[Channel: 36 (5180MHz)]

Power Supply [V]	Temperature [°C]	Measurements Frequency [Hz]	Frequency Tolerance [ppm]
3.30	25(Ref.)	5179983797	0.00000000
	60	5180028355	8.60195741
	50	5179979691	-0.79266657
	40	5179978161	-1.08803429
	30	5179978011	-1.11699191
	20	5179992814	1.74073904
	10	5180001400	3.39827318
	0	5180018963	6.78882432
	-10	5180020053	6.99924969
	-20	5180033429	9.58149715
-30	5180038504	10.56122995	
3.00	25	5179983731	-0.01274135
3.60	25	5179986190	0.46197056

[Channel: 64 (5320MHz)]

Power Supply [V]	Temperature [°C]	Measurements Frequency [Hz]	Frequency Tolerance [%]
3.30	25(Ref.)	5319976566	0.00000000
	60	5320005200	5.38235454
	50	5319970090	-1.21729860
	40	5319964323	-2.30132593
	30	5319978464	0.35676849
	20	5319993601	3.20208177
	10	5320001406	4.66919350
	0	5320004492	5.24927124
	-10	5320026413	9.36977811
	-20	5320025360	9.17184491
-30	5320026346	9.35718407	
3.00	25	5319973383	-0.59831091
3.60	25	5319973713	-0.53628056



Zacta

[Channel: 140 (5700MHz)]

Power Supply [V]	Temperature [°C]	Measurements Frequency [Hz]	Frequency Tolerance [ppm]
3.30	25(Ref.)	5699974330	0.00000000
	60	5700002201	4.88967114
	50	5699975229	0.15772001
	40	5699964539	-1.71772703
	30	5699968667	-0.99351325
	20	5699983989	1.69456904
	10	5699987796	2.36246678
	0	5700007957	5.89950025
	-10	5700017306	7.53968308
	-20	5700010392	6.32669516
-30	5700032874	10.27092345	
3.00	25	5699962960	-1.99474583
3.60	25	5699970294	-0.70807336

[Channel: 165 (5825MHz)]

Power Supply [V]	Temperature [°C]	Measurements Frequency [Hz]	Frequency Tolerance [ppm]
3.30	25(Ref.)	5824959241	0.00000000
	60	5825012971	9.22409888
	50	5824964337	0.87485591
	40	5824971498	2.10422073
	30	5824954690	-0.78129302
	20	5824964033	0.82266670
	10	5824998971	6.82064858
	0	5824989977	5.27660345
	-10	5825016195	9.77757915
	-20	5825019907	10.41483682
-30	5825037013	13.35150973	
3.00	25	5824964983	0.98575797
3.60	25	5824975150	2.73117791

10. AC Power Line Conducted Emissions

10.1 Measurement procedure [FCC 15.207, RSS-Gen 8.8]

Test was applied by following conditions.

Test method	: ANSI C63.10
Frequency range	: 0.15MHz to 30MHz
Test place	: 10m Semi-anechoic chamber
EUT was placed on	: FRP table / (W)2.0m × (D)1.0m × (H)0.8m
Vertical Metal Reference Plane	: (W)2.0m × (H)2.0m 0.4m away from EUT
Test receiver setting	
- Detector	: Quasi-peak, Average
- Bandwidth	: 9kHz

EUT and peripherals are connected to 50Ω/50μH Line Impedance Stabilization Network (LISN) which are connected to reference ground plane, and are placed 80cm away from EUT. Excess of AC power cable is bundled in center.

LISN for peripheral is terminated in 50Ω.

EUT operating mode is selected to emit the maximum noise. Overall frequency range is investigated with spectrum analyzer using peak detector. Maximum emission configuration is determined by manipulating the EUT, peripherals, interconnecting cables. Then, emission measurements are performed with test receiver in above setting to each current-carrying conductor of the mains port. Sufficient time for EUT, peripherals and test equipment is provided in order for them to warm up to their normal operating condition. If the average limit is met when using a quasi-peak detector receiver, the EUT shall be deemed to meet both limits.

- Test configuration

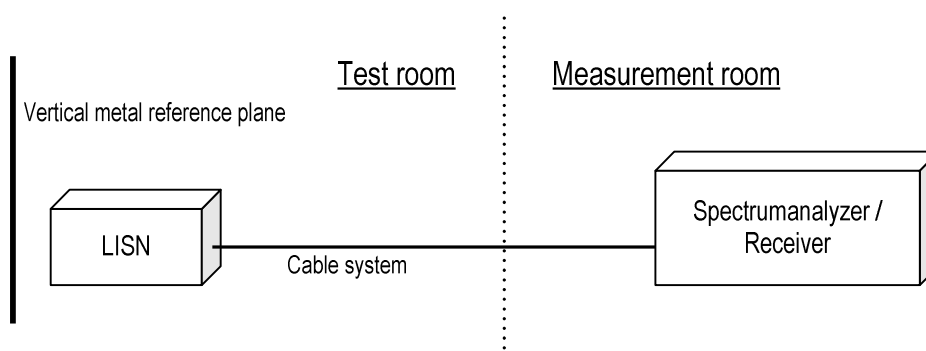

10.2 Calculation method

Emission level = Reading + (LISN. factor + Cable system loss)

Margin = Limit – Emission level

10.3 Limit

Frequency [MHz]	Limit	
	QP [dBuV]	AV [dBuV]
0.15-0.5	66-56*	56-46*
0.5-5	56	46
5-30	60	50

*: The limit decreases linearly with the logarithm of the frequency in the range 0.15MHz to 0.5MHz.



Zacta

10.4 Test data

***** CONDUCTED EMISSION at MAINS PORT *****
 [10m semi-anechoic chamber #1]

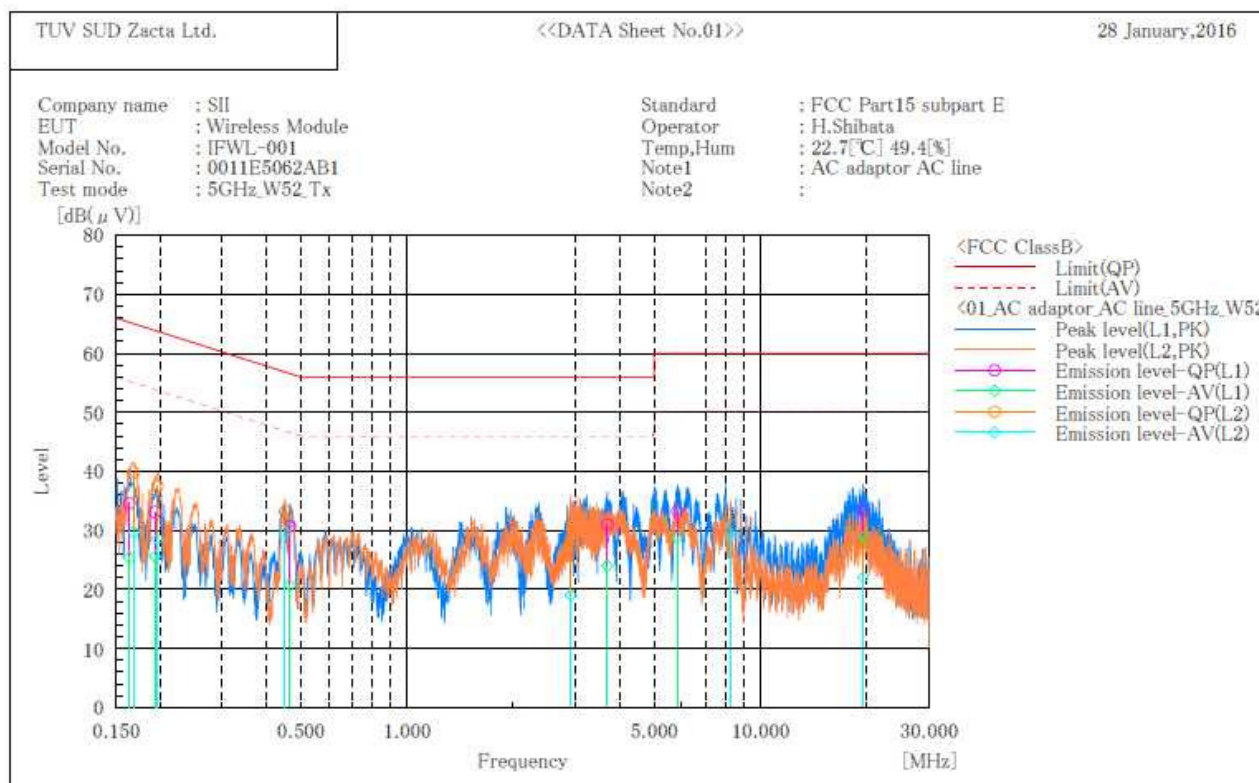

Final Result

--- L1 Phase ---

No.	Frequency [MHz]	Reading QP [dB(μV)]	Reading AV [dB(μV)]	c.f [dB]	Result QP [dB(μV)]	Result AV [dB(μV)]	Limit QP [dB(μV)]	Limit AV [dB(μV)]	Margin QP [dB]	Margin AV [dB]
1	0.164	23.9	14.7	10.7	34.6	25.4	65.3	55.3	30.7	29.9
2	0.194	22.5	15.0	10.6	33.1	25.6	63.9	53.9	30.8	28.3
3	0.467	20.1	10.1	10.6	30.7	20.7	56.6	46.6	25.9	25.9
4	3.691	20.1	13.1	10.9	31.0	24.0	56.0	46.0	25.0	22.0
5	5.831	22.3	17.8	11.0	33.3	28.8	60.0	50.0	26.7	21.2
6	19.550	21.5	16.9	11.8	33.3	28.7	60.0	50.0	26.7	21.3

--- L2 Phase ---

No.	Frequency [MHz]	Reading QP [dB(μV)]	Reading AV [dB(μV)]	c.f [dB]	Result QP [dB(μV)]	Result AV [dB(μV)]	Limit QP [dB(μV)]	Limit AV [dB(μV)]	Margin QP [dB]	Margin AV [dB]
1	0.169	29.0	18.9	10.8	39.8	29.7	65.0	55.0	25.2	25.3
2	0.197	26.8	17.8	10.7	37.5	28.5	63.7	53.7	26.2	25.2
3	0.452	22.5	19.0	10.7	33.2	29.7	56.8	46.8	23.6	17.1
4	2.908	17.5	8.1	10.9	28.4	19.0	56.0	46.0	27.6	27.0
5	8.259	21.4	18.1	11.2	32.6	29.3	60.0	50.0	27.4	20.7
6	19.580	16.2	10.3	11.8	28.0	22.1	60.0	50.0	32.0	27.9



Zacta

***** CONDUCTED EMISSION at MAINS PORT *****
 [10m semi-anechoic chamber #1]

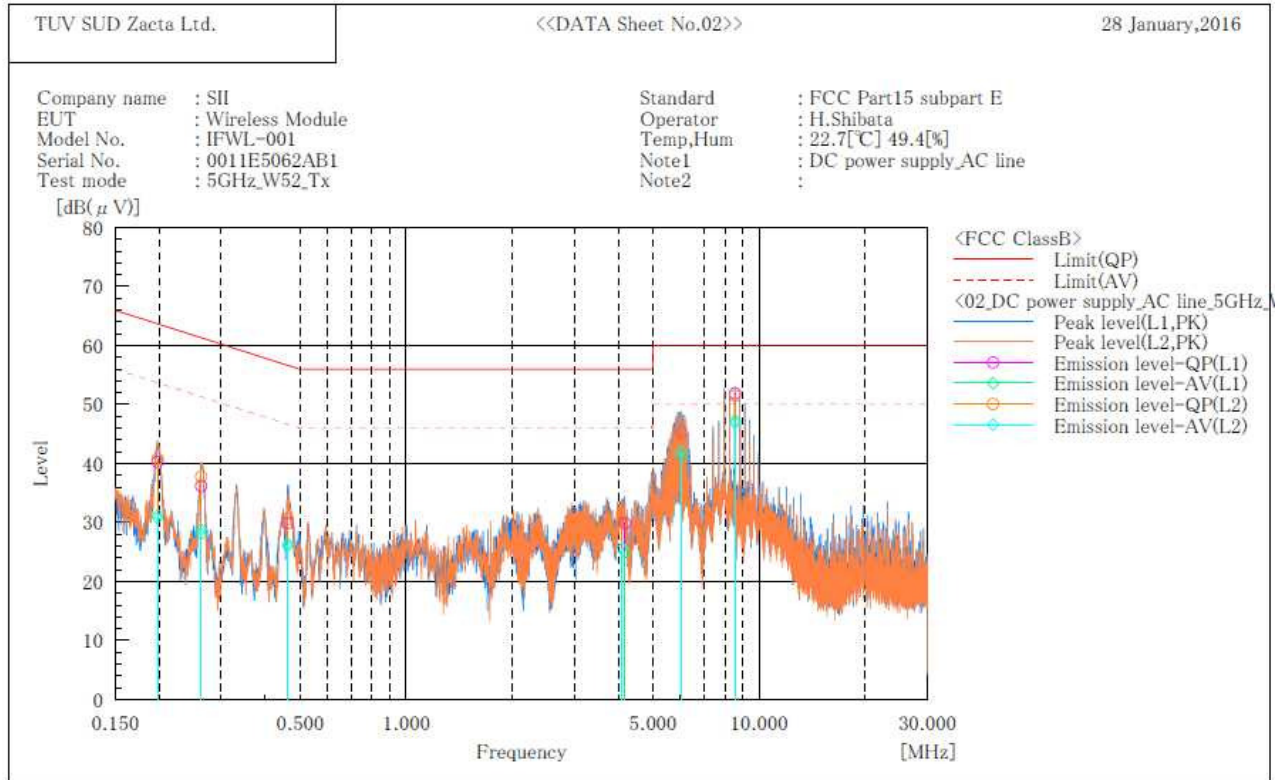

Final Result

--- L1 Phase ---

No.	Frequency [MHz]	Reading QP [dB(μV)]	Reading AV [dB(μV)]	c. f [dB]	Result QP [dB(μV)]	Result AV [dB(μV)]	Limit QP [dB(μV)]	Limit AV [dB(μV)]	Margin QP [dB]	Margin AV [dB]
1	0.198	29.7	20.2	10.6	40.3	30.8	63.7	53.7	23.4	22.9
2	0.263	25.6	17.5	10.6	36.2	28.1	61.3	51.3	25.1	23.2
3	0.463	19.3	15.4	10.6	29.9	26.0	56.6	46.6	26.7	20.6
4	4.166	19.0	14.0	10.9	29.9	24.9	56.0	46.0	26.1	21.1
5	6.020	34.3	30.1	11.0	45.3	41.1	60.0	50.0	14.7	8.9
6	8.547	40.7	36.1	11.2	51.9	47.3	60.0	50.0	8.1	2.7

--- L2 Phase ---

No.	Frequency [MHz]	Reading QP [dB(μV)]	Reading AV [dB(μV)]	c. f [dB]	Result QP [dB(μV)]	Result AV [dB(μV)]	Limit QP [dB(μV)]	Limit AV [dB(μV)]	Margin QP [dB]	Margin AV [dB]
1	0.198	30.1	20.6	10.7	40.8	31.3	63.7	53.7	22.9	22.4
2	0.263	27.1	18.1	10.7	37.8	28.8	61.3	51.3	23.5	22.5
3	0.463	19.9	15.7	10.7	30.6	26.4	56.6	46.6	26.0	20.2
4	4.099	19.2	14.6	11.0	30.2	25.6	56.0	46.0	25.8	20.4
5	6.020	34.2	31.0	11.1	45.3	42.1	60.0	50.0	14.7	7.9
6	8.545	40.2	35.6	11.3	51.5	46.9	60.0	50.0	8.5	3.1



Zacta

***** CONDUCTED EMISSION at MAINS PORT *****
 [10m semi-anechoic chamber #1]

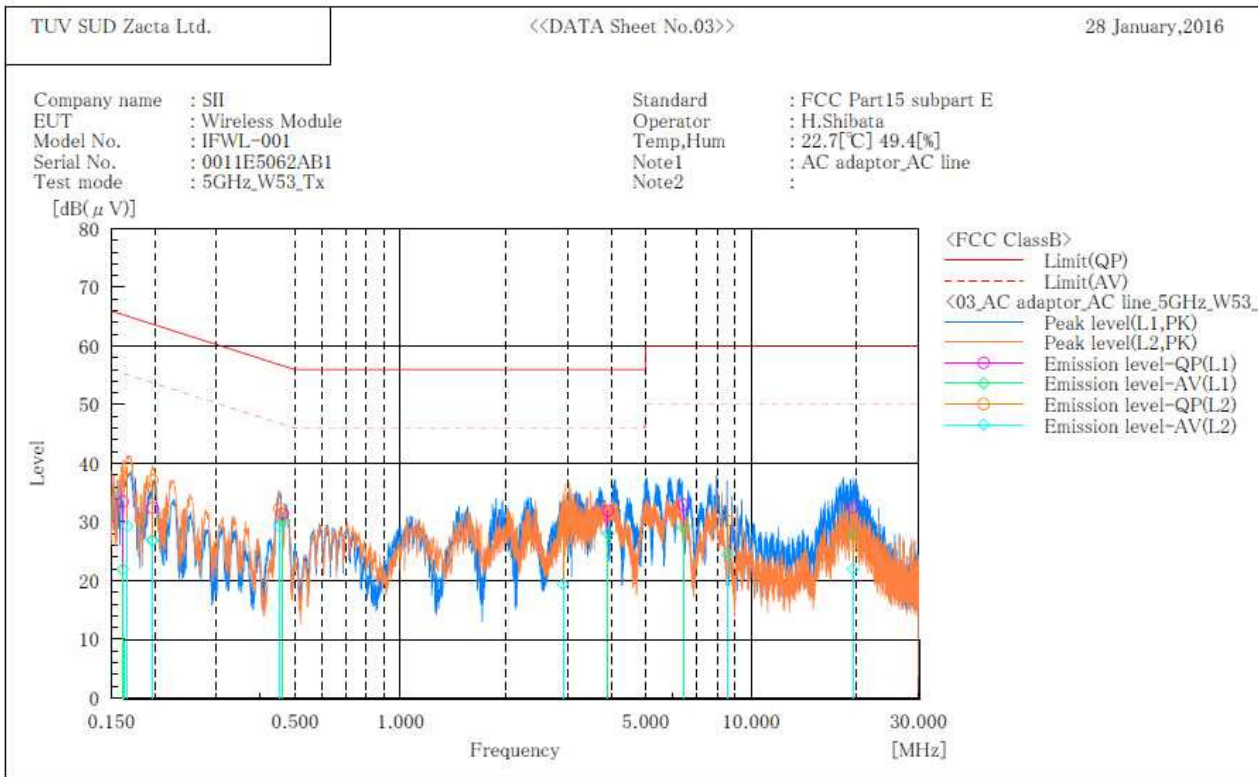

Final Result

— L1 Phase —

No.	Frequency [MHz]	Reading	Reading	c. f [dB]	Result	Result	Limit	Limit	Margin QP [dB]	Margin AV [dB]
		QP [dB(µV)]	AV [dB(µV)]		QP [dB(µV)]	AV [dB(µV)]	QP [dB(µV)]	AV [dB(µV)]		
1	0.162	22.8	11.2	10.7	33.5	21.9	65.4	55.4	31.9	33.5
2	0.197	21.8	16.2	10.6	32.4	26.8	63.7	53.7	31.3	26.9
3	0.462	20.8	19.6	10.6	31.4	30.2	56.7	46.7	25.3	16.5
4	3.910	21.0	17.1	10.9	31.9	28.0	56.0	46.0	24.1	18.0
5	6.420	22.0	18.1	11.0	33.0	29.1	60.0	50.0	27.0	20.9
6	19.466	20.7	16.0	11.8	32.5	27.8	60.0	50.0	27.5	22.2

— L2 Phase —

No.	Frequency [MHz]	Reading	Reading	c. f [dB]	Result	Result	Limit	Limit	Margin QP [dB]	Margin AV [dB]
		QP [dB(µV)]	AV [dB(µV)]		QP [dB(µV)]	AV [dB(µV)]	QP [dB(µV)]	AV [dB(µV)]		
1	0.167	28.5	18.5	10.8	39.3	29.3	65.1	55.1	25.8	25.8
2	0.197	26.4	16.2	10.7	37.1	26.9	63.7	53.7	26.6	26.8
3	0.453	21.6	18.6	10.7	32.3	29.3	56.8	46.8	24.5	17.5
4	2.911	17.8	8.5	10.9	28.7	19.4	56.0	46.0	27.3	26.6
5	8.544	18.9	13.2	11.3	30.2	24.5	60.0	50.0	29.8	25.5
6	19.521	16.5	10.2	11.8	28.3	22.0	60.0	50.0	31.7	28.0



Zacta

***** CONDUCTED EMISSION at MAINS PORT *****
 [10m semi-anechoic chamber #1]

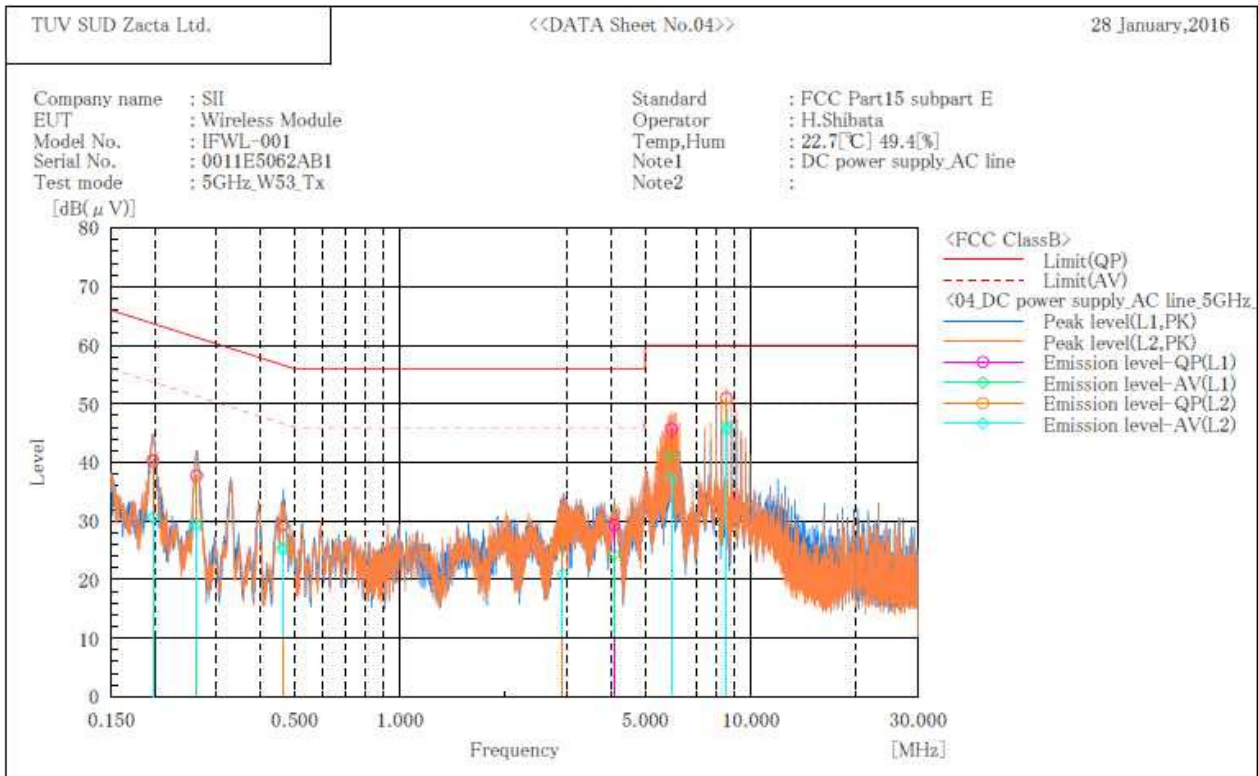

Final Result

--- L1 Phase ---

No.	Frequency [MHz]	Reading QP [dB(μV)]	Reading AV [dB(μV)]	c. f [dB]	Result QP [dB(μV)]	Result AV [dB(μV)]	Limit QP [dB(μV)]	Limit AV [dB(μV)]	Margin QP [dB]	Margin AV [dB]
1	0.198	29.6	20.1	10.6	40.2	30.7	63.7	53.7	23.5	23.0
2	0.263	27.1	18.9	10.6	37.7	29.5	61.3	51.3	23.6	21.8
3	0.464	18.7	14.5	10.6	29.3	25.1	56.6	46.6	27.3	21.5
4	4.092	18.4	13.4	10.9	29.3	24.3	56.0	46.0	26.7	21.7
5	5.955	34.7	30.2	11.0	45.7	41.2	60.0	50.0	14.3	8.8
6	8.545	39.8	34.5	11.2	51.0	45.7	60.0	50.0	9.0	4.3

--- L2 Phase ---

No.	Frequency [MHz]	Reading QP [dB(μV)]	Reading AV [dB(μV)]	c. f [dB]	Result QP [dB(μV)]	Result AV [dB(μV)]	Limit QP [dB(μV)]	Limit AV [dB(μV)]	Margin QP [dB]	Margin AV [dB]
1	0.198	29.8	19.9	10.7	40.5	30.6	63.7	53.7	23.2	23.1
2	0.264	27.1	18.4	10.7	37.8	29.1	61.3	51.3	23.5	22.2
3	0.464	18.6	14.8	10.7	29.3	25.5	56.6	46.6	27.3	21.1
4	2.912	16.8	10.1	10.9	27.7	21.0	56.0	46.0	28.3	25.0
5	5.944	32.8	26.3	11.1	43.9	37.4	60.0	50.0	16.1	12.6
6	8.545	39.6	35.0	11.3	50.9	46.3	60.0	50.0	9.1	3.7



Zacta

***** CONDUCTED EMISSION at MAINS PORT *****
 [10m semi-anechoic chamber #1]

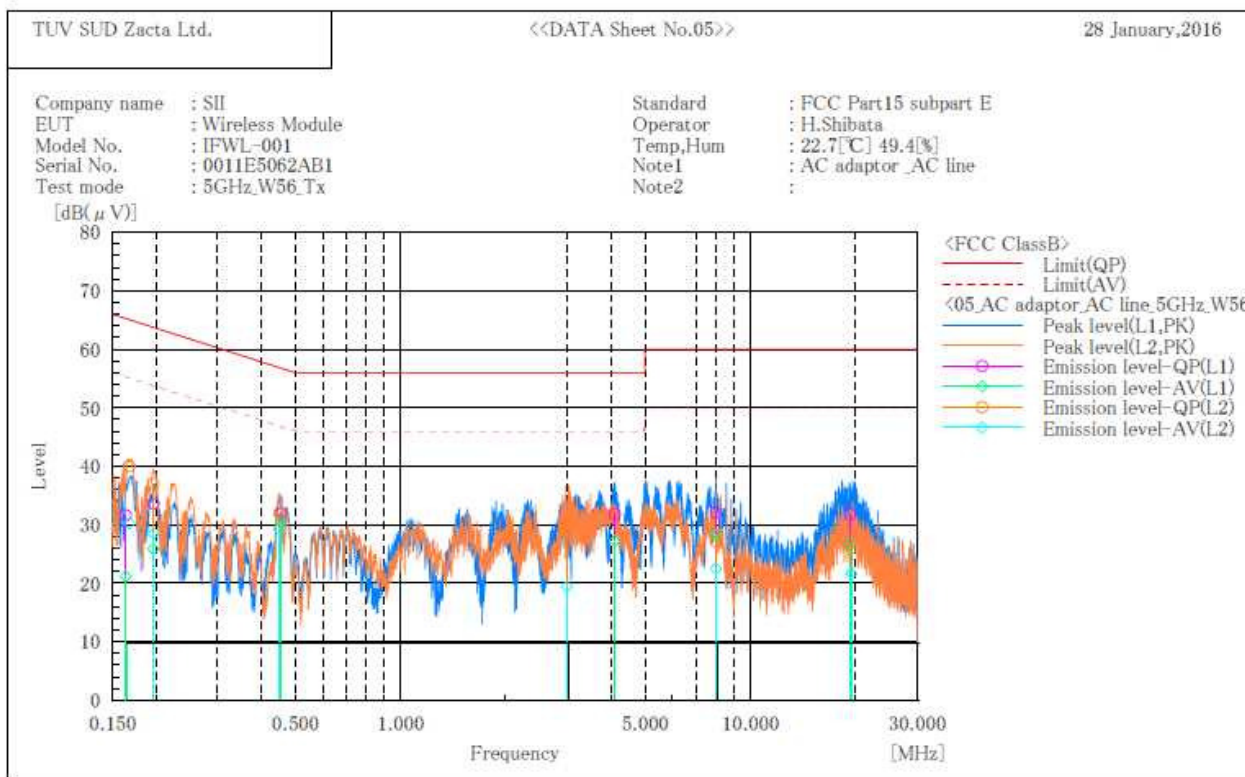

Final Result

--- L1 Phase ---

No.	Frequency [MHz]	Reading	Reading	c. f	Result	Result	Limit	Limit	Margin	Margin
		QP [dB(μV)]	AV [dB(μV)]		[dB]	QP [dB(μV)]	AV [dB(μV)]	QP [dB(μV)]		AV [dB(μV)]
1	0.164	20.9	10.5	10.7	31.6	21.2	65.3	55.3	33.7	34.1
2	0.197	23.0	15.3	10.6	33.6	25.9	63.7	53.7	30.1	27.8
3	0.455	21.3	20.1	10.6	31.9	30.7	56.8	46.8	24.9	16.1
4	4.100	20.9	16.4	10.9	31.8	27.3	56.0	46.0	24.2	18.7
5	7.978	21.0	17.1	11.1	32.1	28.2	60.0	50.0	27.9	21.8
6	19.300	20.1	15.1	11.7	31.8	26.8	60.0	50.0	28.2	23.2

--- L2 Phase ---

No.	Frequency [MHz]	Reading	Reading	c. f	Result	Result	Limit	Limit	Margin	Margin
		QP [dB(μV)]	AV [dB(μV)]		[dB]	QP [dB(μV)]	AV [dB(μV)]	QP [dB(μV)]		AV [dB(μV)]
1	0.168	29.2	19.5	10.8	40.0	30.3	65.1	55.1	25.1	24.8
2	0.197	26.3	17.8	10.7	37.0	28.5	63.7	53.7	26.7	25.2
3	0.451	21.3	18.6	10.7	32.0	29.3	56.9	46.9	24.9	17.6
4	2.991	18.6	8.6	10.9	29.5	19.5	56.0	46.0	26.5	26.5
5	7.980	15.9	11.3	11.2	27.1	22.5	60.0	50.0	32.9	27.5
6	19.411	15.6	9.9	11.8	27.4	21.7	60.0	50.0	32.6	28.3



Zacta

***** CONDUCTED EMISSION at MAINS PORT *****
 [10m semi-anechoic chamber #1]

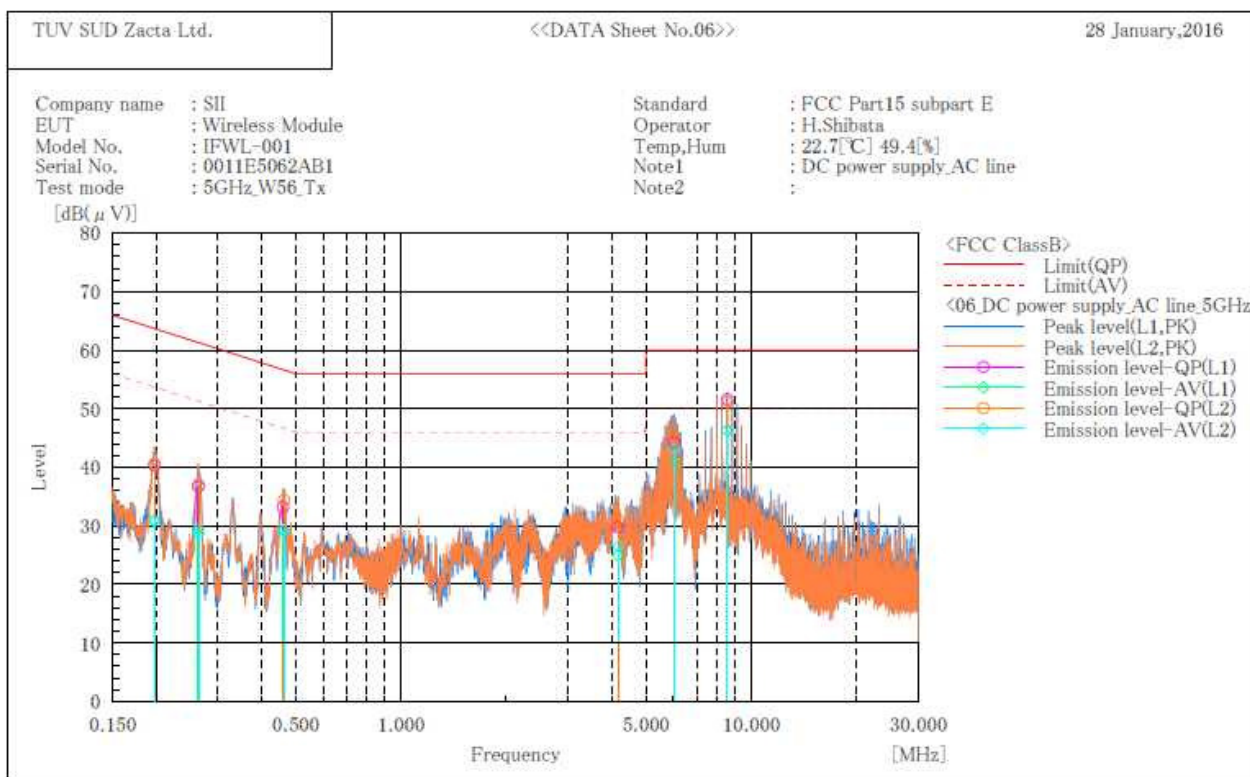

Final Result

--- L1 Phase ---

No.	Frequency [MHz]	Reading QP [dB(μV)]	Reading AV [dB(μV)]	c. f [dB]	Result QP [dB(μV)]	Result AV [dB(μV)]	Limit QP [dB(μV)]	Limit AV [dB(μV)]	Margin QP [dB]	Margin AV [dB]
1	0.198	29.7	20.2	10.6	40.3	30.8	63.7	53.7	23.4	22.9
2	0.264	26.1	18.8	10.6	36.7	29.4	61.3	51.3	24.6	21.9
3	0.461	22.6	18.5	10.6	33.2	29.1	56.7	46.7	23.5	17.6
4	4.166	18.9	14.1	10.9	29.8	25.0	56.0	46.0	26.2	21.0
5	6.020	33.3	29.8	11.0	44.3	40.8	60.0	50.0	15.7	9.2
6	8.545	40.4	35.1	11.2	51.6	46.3	60.0	50.0	8.4	3.7

--- L2 Phase ---

No.	Frequency [MHz]	Reading QP [dB(μV)]	Reading AV [dB(μV)]	c. f [dB]	Result QP [dB(μV)]	Result AV [dB(μV)]	Limit QP [dB(μV)]	Limit AV [dB(μV)]	Margin QP [dB]	Margin AV [dB]
1	0.198	29.9	20.3	10.7	40.6	31.0	63.7	53.7	23.1	22.7
2	0.265	26.3	18.0	10.7	37.0	28.7	61.3	51.3	24.3	22.6
3	0.464	23.7	18.6	10.7	34.4	29.3	56.6	46.6	22.2	17.3
4	4.169	20.0	15.5	11.0	31.0	26.5	56.0	46.0	25.0	19.5
5	6.026	34.3	32.0	11.1	45.4	43.1	60.0	50.0	14.6	6.9
6	8.545	39.8	35.0	11.3	51.1	46.3	60.0	50.0	8.9	3.7



Zacta

***** CONDUCTED EMISSION at MAINS PORT *****
 [10m semi-anechoic chamber #1]

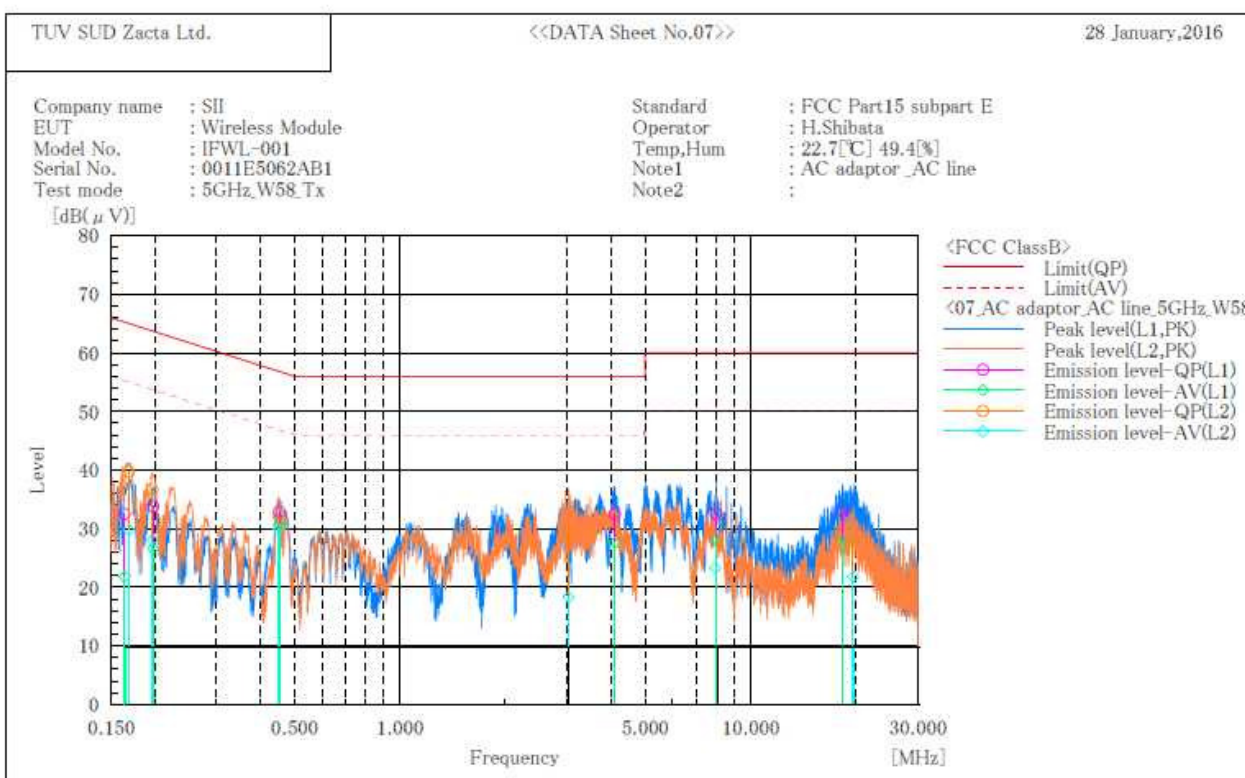

Final Result

--- L1 Phase ---

No.	Frequency [MHz]	Reading QP [dB(μV)]	Reading AV [dB(μV)]	c.f [dB]	Result QP [dB(μV)]	Result AV [dB(μV)]	Limit QP [dB(μV)]	Limit AV [dB(μV)]	Margin QP [dB]	Margin AV [dB]
1	0.164	21.8	11.1	10.7	32.5	21.8	65.3	55.3	32.8	33.5
2	0.198	23.2	16.0	10.6	33.8	26.6	63.7	53.7	29.9	27.1
3	0.453	22.3	20.2	10.6	32.9	30.8	56.8	46.8	23.9	16.0
4	4.103	21.6	16.7	10.9	32.5	27.6	56.0	46.0	23.5	18.4
5	7.974	21.5	17.2	11.1	32.6	28.3	60.0	50.0	27.4	21.7
6	18.329	21.2	16.4	11.7	32.9	28.1	60.0	50.0	27.1	21.9

--- L2 Phase ---

No.	Frequency [MHz]	Reading QP [dB(μV)]	Reading AV [dB(μV)]	c.f [dB]	Result QP [dB(μV)]	Result AV [dB(μV)]	Limit QP [dB(μV)]	Limit AV [dB(μV)]	Margin QP [dB]	Margin AV [dB]
1	0.169	28.9	19.0	10.8	39.7	29.8	65.0	55.0	25.3	25.2
2	0.197	26.0	17.4	10.7	36.7	28.1	63.7	53.7	27.0	25.6
3	0.451	21.7	19.3	10.7	32.4	30.0	56.9	46.9	24.5	16.9
4	3.029	18.5	7.4	10.9	29.4	18.3	56.0	46.0	26.6	27.7
5	7.937	16.9	12.1	11.2	28.1	23.3	60.0	50.0	31.9	26.7
6	19.580	16.2	10.0	11.8	28.0	21.8	60.0	50.0	32.0	28.2



Zacta

***** CONDUCTED EMISSION at MAINS PORT *****
 [10m semi-anechoic chamber #1]

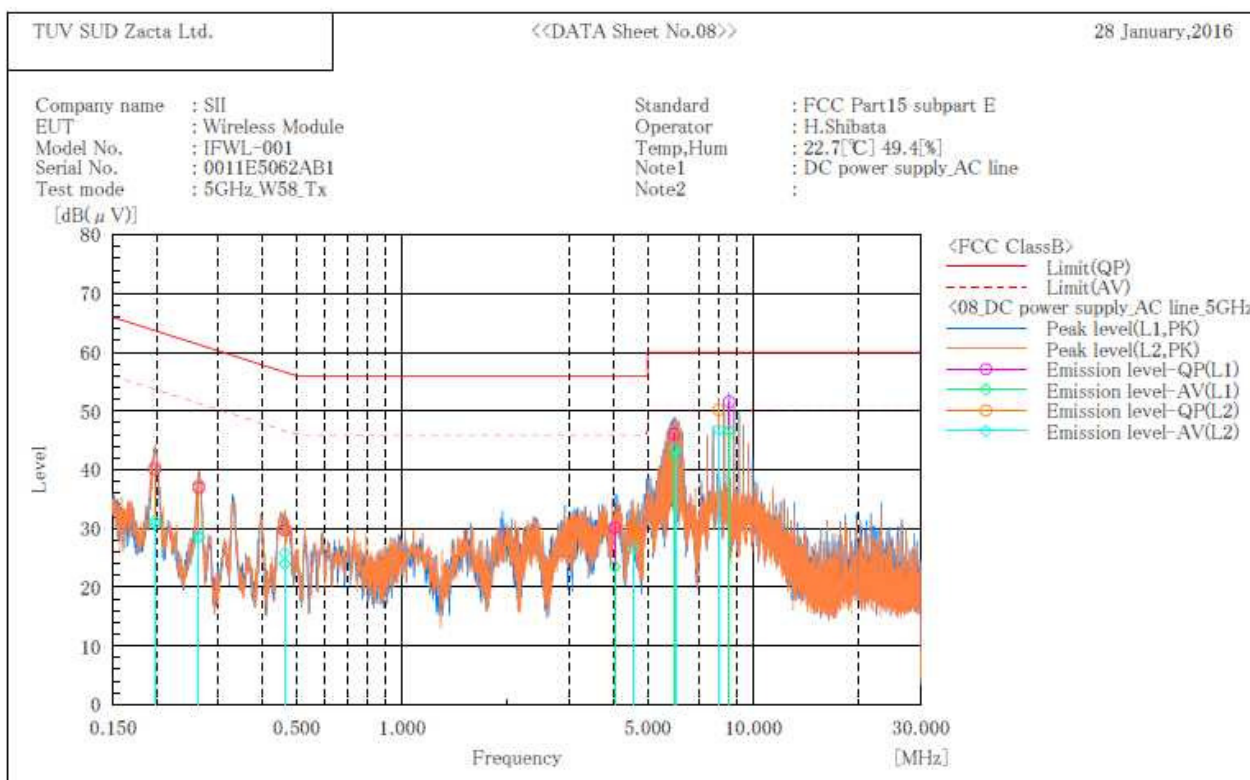

Final Result

--- L1 Phase ---

No.	Frequency [MHz]	Reading QP [dB(μV)]	Reading AV [dB(μV)]	c.f [dB]	Result QP [dB(μV)]	Result AV [dB(μV)]	Limit QP [dB(μV)]	Limit AV [dB(μV)]	Margin QP [dB]	Margin AV [dB]
1	0.198	29.4	20.2	10.6	40.0	30.8	63.7	53.7	23.7	22.9
2	0.264	26.3	17.8	10.6	36.9	28.4	61.3	51.3	24.4	22.9
3	0.464	19.1	13.4	10.6	29.7	24.0	56.6	46.6	26.9	22.6
4	4.038	19.2	12.6	10.9	30.1	23.5	56.0	46.0	25.9	22.5
5	5.956	35.1	32.0	11.0	46.1	43.0	60.0	50.0	13.9	7.0
6	8.547	40.4	35.4	11.2	51.6	46.6	60.0	50.0	8.4	3.4

--- L2 Phase ---

No.	Frequency [MHz]	Reading QP [dB(μV)]	Reading AV [dB(μV)]	c.f [dB]	Result QP [dB(μV)]	Result AV [dB(μV)]	Limit QP [dB(μV)]	Limit AV [dB(μV)]	Margin QP [dB]	Margin AV [dB]
1	0.198	29.8	20.6	10.7	40.5	31.3	63.7	53.7	23.2	22.4
2	0.264	26.6	18.0	10.7	37.3	28.7	61.3	51.3	24.0	22.6
3	0.464	19.2	15.1	10.7	29.9	25.8	56.6	46.6	26.7	20.8
4	4.569	19.7	15.6	11.0	30.7	26.6	56.0	46.0	25.3	19.4
5	6.026	34.5	32.6	11.1	45.6	43.7	60.0	50.0	14.4	6.3
6	7.977	39.0	35.6	11.2	50.2	46.8	60.0	50.0	9.8	3.2

11. Duty Cycle

11.1 Measurement procedure

[KDB 789033 Zero-Span Spectrum Analyzer Method]

The duty cycle is measured with a spectrum analyzer connected to the antenna terminal, while EUT is operating in transmission mode at the appropriate center frequency.

The spectrum analyzer is set to;

- a) RBW \geq largest available value,
- b) VBW \geq RBW,
- c) Span = 0Hz,
- d) Sweep = auto,
- e) Detector = Peak
- f) Trace mode = Single

The EUT was set to operate with following conditions.

- 5.2GHz Band, 5.3GHz Band, 5.6GHz Band, 5.8GHz Band

The test mode of EUT is as follows.

- Tx mode

- Test configuration

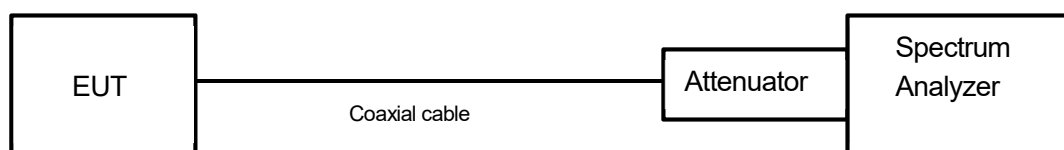

11.2 Limit

None

11.3 Measurement result

Date : January 8, 2016
 Temperature : 21.4 [°C]
 Humidity : 49.2 [%]
 Test place : Shielded room No.4

Tested by : Hikaru Shibata

Mode	Channel	Frequency (MHz)	Duty Cycle				DCF (dB) 10log(1/x)	DCF (dB) 20log(1/x)
			On Time(ms)	On+Off Time(ms)	X	1/T		
802.11a	36	5180	1.358	1.404	0.967	736.4	0.145	0.289
	40	5200						
	58	5240						
	52	5260	1.360	1.404	0.969	735.3	0.138	0.277
	56	5280						
	64	5320						
	100	5500	1.358	1.404	0.967	736.4	0.145	0.289
	120	5600						
	140	5700						
	149	5745	1.360	1.406	0.967	735.3	0.144	0.289
	157	5785						
165	5825							

Note: X = On time / (On + Off time)

Mode	Channel	Frequency (MHz)	Duty Cycle				DCF (dB) 10log(1/x)	DCF (dB) 20log(1/x)
			On Time(ms)	On+Off Time(ms)	X	1/T		
802.11n (20MHz)	36	5180	1.272	1.316	0.967	786.2	0.148	0.295
	40	5200						
	58	5240						
	52	5260	1.268	1.316	0.964	788.6	0.161	0.323
	56	5280						
	64	5320						
	100	5500	1.272	1.316	0.967	786.2	0.148	0.295
	120	5600						
	140	5700						
	149	5745	1.270	1.314	0.967	787.4	0.148	0.296
	157	5785						
165	5825							

Note: X = On time / (On + Off time)

11.4 Trace data
[IEEE802.11a]

Channel: 40

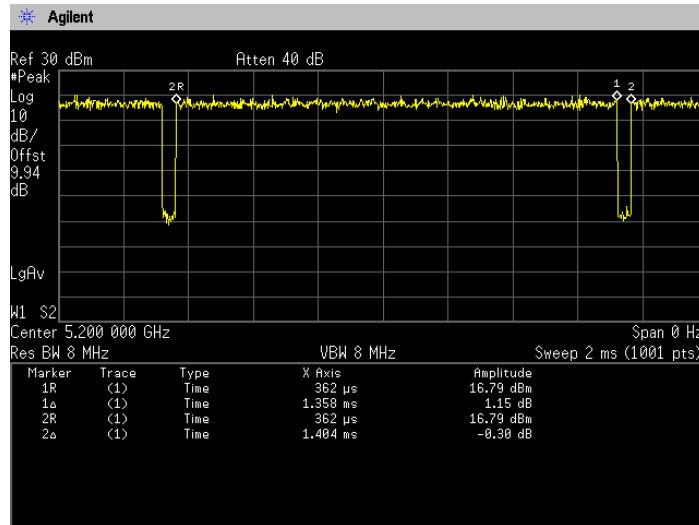

Channel: 56

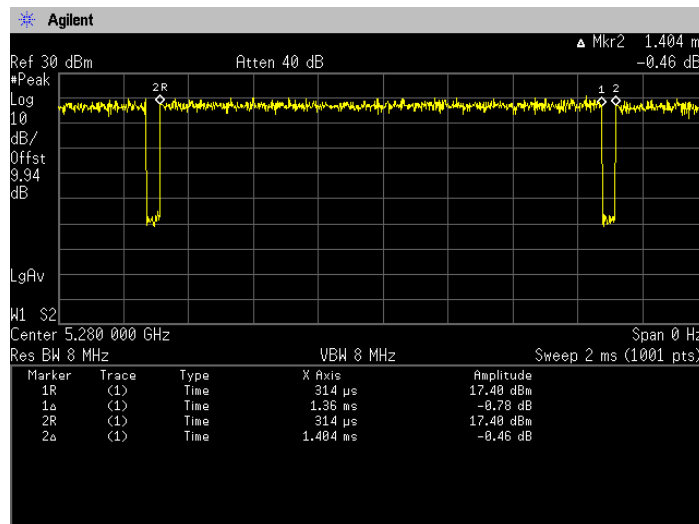



Zacta

Channel: 120

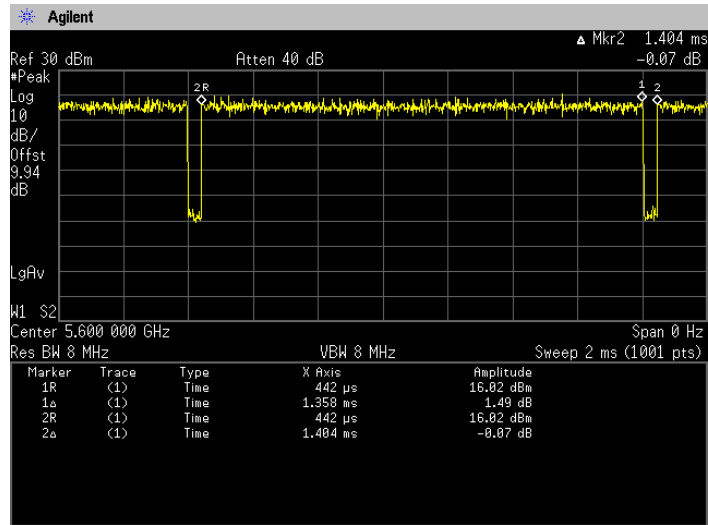

Channel: 157

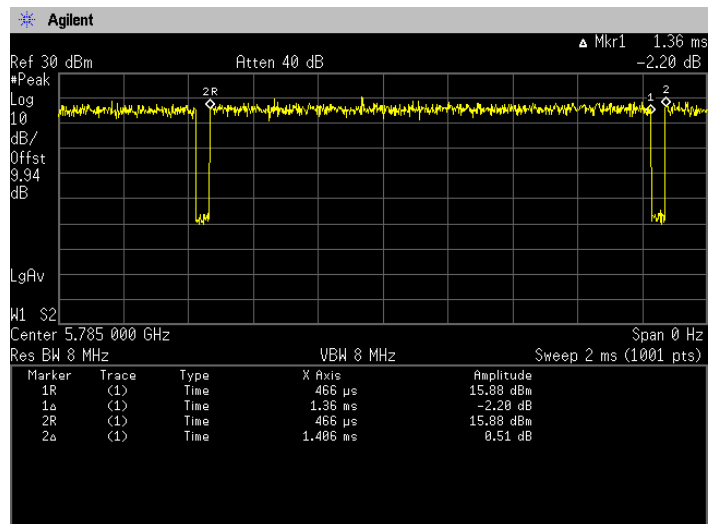

[IEEE802.11n (HT20)]

Channel: 40

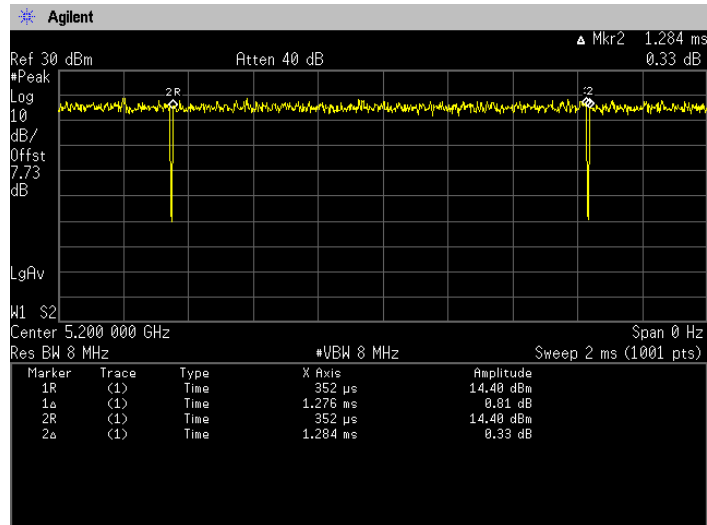

Channel: 56

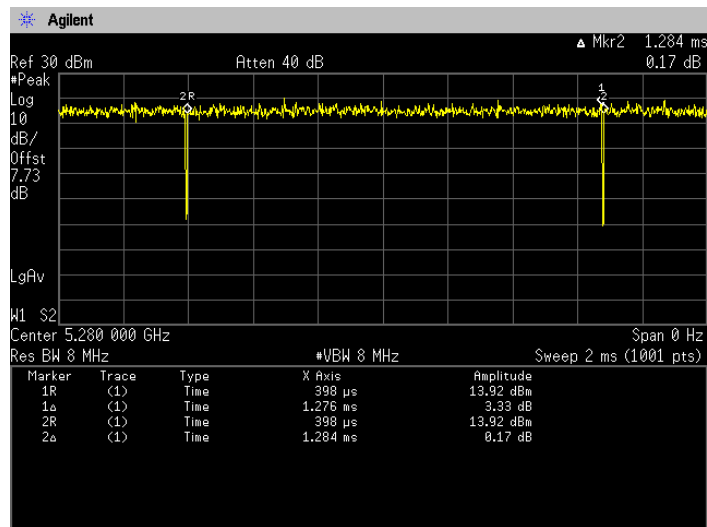



Zacta

Channel: 120

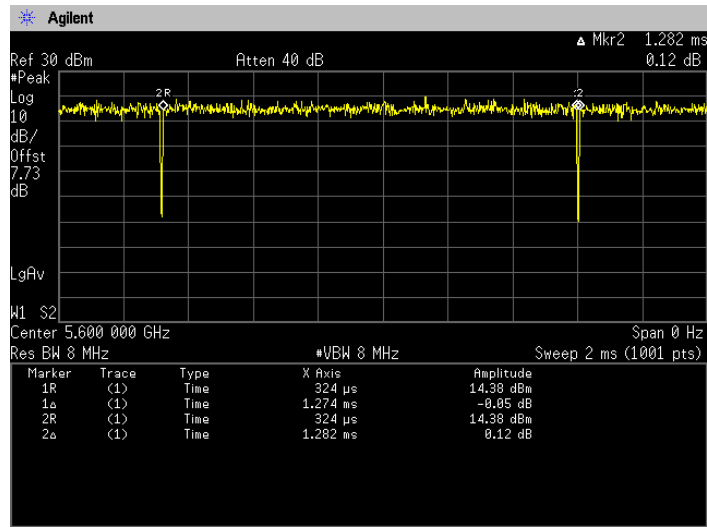

Channel: 157

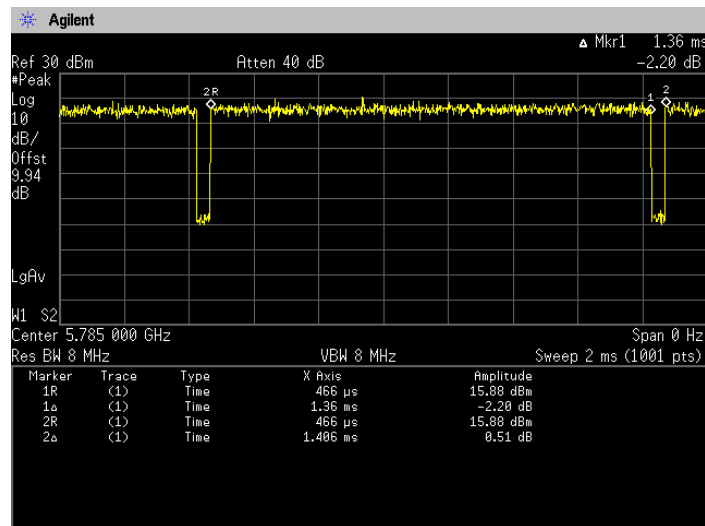



Zacta

12. Antenna requirement

According to FCC section 15.203, an intentional radiator shall be designed to ensure that no antenna other than that furnished by the responsible party shall be used with the device.

The antenna is a special antenna mounted inside of the EUT. Therefore, the EUT complies with the antenna requirement of FCC section 15.203.

13. Uncertainty of measurement

Expanded uncertainties stated are calculated with a coverage Factor $k=2$.

Please note that these results are not taken into account when measurement uncertainty considerations contained in ETSI TR 100 028-0011 determining compliance or non-compliance with test result.

Test item	Measurement uncertainty
Conducted emission at mains port	$\pm 3.0\text{dB}$
Radiated emission (9kHz – 30MHz)	$\pm 4.4\text{dB}$
Radiated emission (30MHz – 1000MHz)	$\pm 4.5\text{dB}$
Radiated emission (1000MHz – 26GHz)	$\pm 3.9\text{dB}$



Zacta

14. Laboratory description

1. Location:

TÜV SÜD Zacta Ltd. Yonezawa Testing Center
 4149-7 Hachimanpara 5-chome Yonezawa-shi Yamagata 992-1128 Japan
 Phone: +81-238-28-2880 Fax: +81-238-28-2888

2. Facility filing information:

1) NVLAP accreditation: NVLAP Lab. code: 200306-0

2) VLAC accreditation: Lab. code: VLAC-013

Site name	Radiated emission	Conducted emission for mains port	Conducted emission for telecom port	Radiated emission (CMAD)	Expiry Date
3m Semi-anechoic chamber	VLAC-013	VLAC-013	VLAC-013	-	Jul. 3, 2017
10m Semi-anechoic chamber No.1				VLAC-013	
10m Semi-anechoic chamber No.2					
Shielded room No.1	-	VLAC-013		-	

3) FCC filing:

Site name	Registration Number	Expiry Date
Site 3	91065	Oct. 1, 2017
3m Semi-anechoic chamber	540072	Feb. 20, 2017
10m Semi-anechoic chamber No.1		
10m Semi-anechoic chamber No.2		
Shielded room No.1		

4) Industry Canada Oats site filing:

Site name	Sites on file: Oats 3m/10m	Expiry Date
Site 3	4224A-3	Dec. 3, 2017
3m Semi-anechoic chamber	4224A-4	
10m Semi-anechoic chamber No.1	4224A-5	
10m Semi-anechoic chamber No.2	4224A-6	Jan. 15, 2017

5) VCCI site filing:

Site name	Radiated emission	Conducted emission for mains port	Conducted emission for telecom port	Expiry Date
Site 3	R-138	C-134	T-1222	Nov. 16, 2017
3m Semi-anechoic chamber	A-0166	A-0166	A-0166	Jul. 3, 2015
10m Semi-anechoic chamber No.1				
10m Semi-anechoic chamber No.2				
Shielded room No.1	-			

6) TÜV SÜD PS authorization:

Authorized as an EMC test laboratory

7) TÜV Rheinland authorization:

Authorized as an EMC test laboratory

Appendix A. Test equipment

Antenna port conducted test

Equipment	Company	Model No.	Serial No.	Cal. due	Cal. date
Spectrum analyzer	Agilent Technologies	E4440A	US44302655	Jun. 30, 2016	Jun. 11, 2015
Microwave cable	RS	YH-13S5	N/A (S403)	May 31, 2016	May 10, 2015
Coaxial cable	RS	YH20_S1	N/A (S389)	Aug. 31, 2016	Aug. 6, 2015
Attenuator	Weinschel	56-10	J4993	Nov. 30, 2016	Nov. 12, 2015
Power meter	ROHDE&SCHWARZ	NRP2	103269	Jun. 30, 2016	Jun. 25, 2015
Power sensor	ROHDE&SCHWARZ	NRP-Z81	102467	Jun. 30, 2016	Jun. 25, 2015

Radiated emission

Equipment	Company	Model No.	Serial No.	Cal. Due	Cal. Date
EMI Receiver	ROHDE&SCHWARZ	ESCI	100765	Sep. 30, 2016	Sep. 2, 2015
Preamplifier	ANRITSU	MH648A	M08067	Jun. 30, 2016	Jun. 30, 2015
Loop antenna	ROHDE&SCHWARZ	HFH2-Z2	892246/010	Apr. 30, 2016	Apr. 2, 2015
Attenuator	TDC	TAT-43B-06	N/A (S209)	Apr. 30, 2016	Apr. 16, 2015
Biconical antenna	Schwarzbeck	VHA9103/BBA9106	2850	Jun. 30, 2016	Jun. 17, 2015
Log periodic antenna	Schwarzbeck	UHALP9108A	0991	Jun. 30, 2016	Jun. 17, 2015
Attenuator	TME	CFA-01NPJ-6	N/A (S273)	Jun. 30, 2016	Jun. 23, 2015
Attenuator	TME	CFA-01NPJ-3	N/A (S270)	Jun. 30, 2016	Jun. 23, 2015
Spectrum analyzer	Agilent Technologies	E4447A	MY46180188	Mar. 31, 2016	Mar. 31, 2015
Preamplifier	Agilent Technologies	8449B	3008A1008	Oct. 31, 2016	Oct. 29, 2015
Double ridged guide antenna	ETS LINDGREN	3117	00052315	Feb. 29, 2016	Feb. 20, 2015
Preamplifier	TSJ	MLA-100M18-B02-40	1929118	May 31, 2016	May 1, 2015
Attenuator	HUBER+SUHNER	6803.17.B	N/A(2340)	Feb. 29, 2016	Mar. 9, 2015
Attenuator	AEROFLEX	26A-10	081217-08	May 31, 2016	May 5, 2015
Broad-Band Horn Antenna	Schwarzbeck	BBHA9170	BBHA9170189	Jun. 30, 2016	Jun. 16, 2015
Preamplifier	TSJ	MLA-1840-B03-35	1240332	Jun. 31, 2016	Jun. 6, 2015
Notch filter	Micro-Tronics	BRM50706	003	July 31, 2016	July 12, 2015
Notch filter	Micro-Tronics	BRM50716	006	July 31, 2016	July 12, 2015
Microwave cable	SUHNER	SUCOFLEX104/9m	346315/4	May 31, 2016	May 29, 2015
		SUCOFLEX104/1m	MY24628/4	May 31, 2016	May 29, 2015
		SUCOFLEX104/2m	317672/4	May 31, 2016	May 29, 2015
		SUCOFLEX104/13m	41623/6	May 31, 2016	May 29, 2015
Microwave cable	HUBER+SUHNER	SUCOFLEX104/9m	MY23758/4	May 31, 2016	May 29, 2015
PC	HP	dc7800small	JPA7450FPJ	Apr. 30, 2016	Apr. 30, 2015
Software	TOYO Corporation	EP5/RE-AJ	0611193/V5.4.011	N/A	N/A
10m Semi-anechoic chamber	TOKIN	N/A	N/A (9001-NSA 3m)	Apr. 30, 2016	Apr. 30, 2015
10m Semi-anechoic chamber	TOKIN	N/A	N/A (9001-SVSWR)	Apr. 30, 2016	Apr. 28, 2015

Conducted emission at mains port

Equipment	Company	Model No.	Serial No.	Cal. due	Cal. date
EMI Receiver	ROHDE&SCHWARZ	ESCI	100765	Sep. 30, 2016	Sep. 2, 2015
Attenuator	TYC	BA-PJ-10	N/A (S344)	Apr. 30, 2016	Apr. 6, 2015
Line impedance stabilization network for EUT	Kyoritsu Electrical Works, Ltd.	KNW-407F	8-2003-1	Mar. 31, 2016	Mar. 5, 2015
Line impedance stabilization network	Kyoritsu Electrical Works, Ltd.	KNW-242F	8-1094-5	Jun. 30, 2016	Jun. 24, 2015
5Coaxial cable	FUJIKURA	5D-2W/4m	N/A (S349)	Feb. 29, 2016	Feb. 27, 2015
Coaxial cable	SUHNER	SUCOFLEX104/2m	317672/4	May 31, 2016	May 29, 2015
Coaxial cable	SUHNER	RG214/U/25m	N/A (S191)	Feb. 29, 2016	Feb. 27, 2015
PC	HP	Dc7800small	JPA7450FPJ	N/A	N/A
Software	TOYO Corporation	EP5/CE-AJ	0611193/V5.6.000	N/A	N/A

*: The calibrations of the above equipment are traceable to NIST or equivalent standards of the reference organizations.