

## FCC Test Report

**Report No.:** RF200206E05

**FCC ID:** C3K1884

**Test Model:** 1884

**Received Date:** Feb. 06, 2020

**Test Date:** Mar. 23 to May 19, 2020

**Issued Date:** June 24, 2020

**Applicant:** Microsoft Corporation

**Address:** One Microsoft Way, Redmond, Washington 98052-6399, United States

**Issued By:** Bureau Veritas Consumer Products Services (H.K.) Ltd., Taoyuan Branch  
Hsin Chu Laboratory

**Lab Address:** E-2, No.1, Li Hsin 1st Road, Hsinchu Science Park, Hsinchu City 300,  
Taiwan

**Test Location:** E-2, No.1, Li Hsin 1st Road, Hsinchu Science Park, Hsinchu City 300,  
Taiwan

**FCC Registration /  
Designation Number:** 723255 / TW2022



This report is for your exclusive use. Any copying or replication of this report to or for any other person or entity, or use of our name or trademark, is permitted only with our prior written permission. This report sets forth our findings solely with respect to the test samples identified herein. The results set forth in this report are not indicative or representative of the quality or characteristics of the lot from which a test sample was taken or any similar or identical product unless specifically and expressly noted. Our report includes all of the tests requested by you and the results thereof based upon the information that you provided to us. You have 60 days from date of issuance of this report to notify us of any material error or omission caused by our negligence, provided, however, that such notice shall be in writing and shall specifically address the issue you wish to raise. A failure to raise such issue within the prescribed time shall constitute your unqualified acceptance of the completeness of this report, the tests conducted and the correctness of the report contents. Unless specific mention, the uncertainty of measurement has been explicitly taken into account to declare the compliance or non-compliance to the specification. The report must not be used by the client to claim product certification, approval, or endorsement by TAF or any government agencies.

## Table of Contents

<b>Release Control Record</b> .....	<b>4</b>
<b>1 Certificate of Conformity</b> .....	<b>5</b>
<b>2 Summary of Test Results</b> .....	<b>6</b>
2.1 Measurement Uncertainty.....	6
2.2 Modification Record.....	6
<b>3 General Information</b> .....	<b>7</b>
3.1 General Description of EUT.....	7
3.2 Description of Test Modes.....	9
3.2.1 Test Mode Applicability and Tested Channel Detail.....	10
3.3 Duty Cycle of Test Signal.....	12
3.4 Description of Support Units.....	13
3.4.1 Configuration of System under Test.....	14
3.5 General Description of Applied Standards and References.....	15
<b>4 Test Types and Results</b> .....	<b>16</b>
4.1 Radiated Emission and Bandedge Measurement (Radiated Versus Conducted).....	16
4.1.1 Limits of Radiated Emission and Bandedge Measurement.....	16
4.1.2 Test Instruments.....	17
4.1.3 Test Procedures.....	19
4.1.4 Deviation from Test Standard.....	20
4.1.5 Test Setup.....	21
4.1.6 EUT Operating Conditions.....	22
4.1.7 Test Results (Radiated Measurement).....	23
4.1.7.1 Test Results (Mode 1).....	24
4.1.7.2 Test Results (Mode 2).....	38
4.1.8 Test Results (Conducted Measurement).....	64
4.1.8.1 Test Results (Mode 1).....	65
4.1.8.2 Test Results (Mode 2).....	91
4.2 Conducted Emission Measurement.....	117
4.2.1 Limits of Conducted Emission Measurement.....	117
4.2.2 Test Instruments.....	117
4.2.3 Test Procedures.....	118
4.2.4 Deviation from Test Standard.....	118
4.2.5 Test Setup.....	118
4.2.6 EUT Operating Conditions.....	118
4.2.7 Test Results.....	119
4.3 6dB Bandwidth Measurement.....	121
4.3.1 Limits of 6dB Bandwidth Measurement.....	121
4.3.2 Test Setup.....	121
4.3.3 Test Instruments.....	121
4.3.4 Test Procedure.....	121
4.3.5 Deviation from Test Standard.....	121
4.3.6 EUT Operating Conditions.....	121
4.3.7 Test Result (Mode 1).....	122
4.3.8 Test Result (Mode 2).....	123
4.4 Conducted Output Power Measurement.....	125
4.4.1 Limits of Conducted Output Power Measurement.....	125
4.4.2 Test Setup.....	125
4.4.3 Test Instruments.....	125
4.4.4 Test Procedures.....	125
4.4.5 Deviation from Test Standard.....	125
4.4.6 EUT Operating Conditions.....	125
4.4.7 Test Results (Mode 1).....	126
4.4.8 Test Results (Mode 2).....	127

4.5	Power Spectral Density Measurement.....	129
4.5.1	Limits of Power Spectral Density Measurement .....	129
4.5.2	Test Setup.....	129
4.5.3	Test Instruments .....	129
4.5.4	Test Procedure .....	129
4.5.5	Deviation from Test Standard .....	129
4.5.6	EUT Operating Condition .....	129
4.5.7	Test Results (Mode 1).....	130
4.5.8	Test Results (Mode 2).....	131
4.6	Conducted Out of Band Emission Measurement.....	133
4.6.1	Limits of Conducted Out of Band Emission Measurement .....	133
4.6.2	Test Setup.....	133
4.6.3	Test Instruments .....	133
4.6.4	Test Procedure .....	133
4.6.5	Deviation from Test Standard .....	133
4.6.6	EUT Operating Condition .....	133
4.6.7	Test Results (Mode 1).....	133
4.6.8	Test Results (Mode 2).....	138
<b>5</b>	<b>Pictures of Test Arrangements.....</b>	<b>142</b>
	<b>Appendix – Information of the Testing Laboratories .....</b>	<b>143</b>

### Release Control Record

Issue No.	Description	Date Issued
RF200206E05	Original release.	June 24, 2020

## 1 Certificate of Conformity

**Product:** 802.11a/b/g/n/ac 2T2R dual-band wireless LAN radio

**Brand:** Microsoft

**Test Model:** 1884

**Sample Status:** ENGINEERING SAMPLE

**Applicant:** Microsoft Corporation

**Test Date:** Mar. 23 to May 19, 2020

**Standards:** 47 CFR FCC Part 15, Subpart C (Section 15.247)  
ANSI C63.10: 2013

The above equipment has been tested by **Bureau Veritas Consumer Products Services (H.K.) Ltd., Taoyuan Branch**, and found compliance with the requirement of the above standards. The test record, data evaluation & Equipment Under Test (EUT) configurations represented herein are true and accurate accounts of the measurements of the sample's EMC characteristics under the conditions specified in this report.

**Prepared by :** Phoenix Huang , **Date:** June 24, 2020  
Phoenix Huang / Specialist

**Approved by :** Clark Lin , **Date:** June 24, 2020  
Clark Lin / Technical Manager

## 2 Summary of Test Results

47 CFR FCC Part 15, Subpart C (Section 15.247)			
FCC Clause	Test Item	Result	Remarks
15.207	AC Power Conducted Emission	PASS	Meet the requirement of limit. Minimum passing margin is -8.61 dB at 0.72813 MHz.
15.205 / 15.209 / 15.247(d)	Radiated Emissions and Band Edge Measurement	PASS	Meet the requirement of limit. Minimum passing margin is -1.51 dB at 2390.00 MHz, 2389.99 MHz.
15.247(d)	Antenna Port Emission	PASS	Meet the requirement of limit.
15.247(a)(2)	6dB bandwidth	PASS	Meet the requirement of limit.
15.247(b)	Conducted power	PASS	Meet the requirement of limit.
15.247(e)	Power Spectral Density	PASS	Meet the requirement of limit.
15.203	Antenna Requirement	PASS	No antenna connector is used.

Note: Determining compliance based on the results of the compliance measurement, not taking into account measurement instrumentation uncertainty.

### 2.1 Measurement Uncertainty

Where relevant, the following measurement uncertainty levels have been estimated for tests performed on the EUT as specified in CISPR 16-4-2:

Measurement	Frequency	Expanded Uncertainty (k=2) ( $\pm$ )
Conducted Emissions at mains ports	150kHz ~ 30MHz	1.9 dB
Conducted emissions	9kHz ~ 40GHz	2.5 dB
Radiated Emissions up to 1 GHz	9kHz ~ 30MHz	3.1 dB
	30MHz ~ 1GHz	5.4 dB
Radiated Emissions above 1 GHz	1GHz ~ 18GHz	5.0 dB
	18GHz ~ 40GHz	5.3 dB

### 2.2 Modification Record

There were no modifications required for compliance.

### 3 General Information

#### 3.1 General Description of EUT

Product	802.11a/b/g/n/ac 2T2R dual-band wireless LAN radio
Brand	Microsoft
Test Model	1884
Status of EUT	ENGINEERING SAMPLE
Power Supply Rating	3.3Vdc from host equipment
Modulation Type	CCK, DQPSK, DBPSK for DSSS 64QAM, 16QAM, QPSK, BPSK for OFDM 256QAM for OFDM in 11ac mode only
Modulation Technology	DSSS, OFDM
Transfer Rate	802.11b: up to 11 Mbps 802.11a/g: up to 54 Mbps 802.11n: up to 300 Mbps 802.11ac: up to 866.7 Mbps
Operating Frequency	<b>2.4GHz:</b> 2.412 ~ 2.462GHz <b>5GHz:</b> 5.18 ~ 5.24 GHz, 5.26 ~ 5.32 GHz, 5.50 ~ 5.72 GHz, 5.745 ~ 5.825 GHz
Number of Channel	<b>2.4GHz:</b> 802.11b, 802.11g, 802.11n (HT20): 11 802.11n (HT40): 7 <b>5GHz:</b> 802.11a, 802.11n (HT20), 802.11ac (VHT20): 25 802.11n (HT40), 802.11ac (VHT40): 12 802.11ac (VHT80): 6
Output Power	<b>2TX mode:</b> <b>2.4 GHz:</b> 473.454 mW <b>5.18 ~ 5.24 GHz:</b> 62.543 mW <b>5.26 ~ 5.32 GHz:</b> 69.112 mW <b>5.5 ~ 5.72 GHz:</b> 57.931 mW <b>5.745 ~ 5.825 GHz:</b> 63.567 mW <b>1TX mode:</b> <b>2.4 GHz:</b> 284.446 mW <b>5.18 ~ 5.24 GHz:</b> 44.566 mW <b>5.26 ~ 5.32 GHz:</b> 44.157 mW <b>5.5 ~ 5.72 GHz:</b> 45.499 mW <b>5.745 ~ 5.825 GHz:</b> 44.463 mW
Antenna Type	Refer to Note
Antenna Connector	Refer to Note
Accessory Device	NA
Data Cable Supplied	NA

Note:

- 2.4GHz and 5GHz technology cannot transmit at same time.
- The antennas provided to the EUT, please refer to the following table:

Ant. No.	Transmitter Circuit	Ant.Gain (dBi)	Freq. Range (GHz)	Ant. Type	Connector Type
1	0	2.88	2.4~2.4835	PCB	None
		3.43	5.15~5.25		
		3.65	5.25~5.35		
		3.22	5.47~5.725		
		3.52	5.725~5.85		
2	1	3.62	2.4~2.4835	PCB	None
		3.41	5.15~5.25		
		3.56	5.25~5.35		
		3.74	5.47~5.725		
		3.2	5.725~5.85		

- The EUT incorporates a MIMO function.

#### 2.4GHz Band

MODULATION MODE	DATA RATE (MCS)	TX & RX CONFIGURATION	
802.11b	1 ~ 11Mbps	1TX (Fixed Chain 0)	2RX
802.11g	6 ~ 54Mbps	1TX (Fixed Chain 0)	2RX
802.11n (HT20)	MCS 0~7	1TX (Fixed Chain 0)	2RX
	MCS 8~15*	2TX	
802.11n (HT40)	MCS 0~7	1TX (Fixed Chain 0)	2RX
	MCS 8~15*	2TX	

#### 5GHz Band

MODULATION MODE	DATA RATE (MCS)	TX & RX CONFIGURATION	
802.11a	6 ~ 54Mbps	1TX (Fixed Chain 0)	2RX
802.11n (HT20)	MCS 0~7	1TX (Fixed Chain 0)	2RX
	MCS 8~15*	2TX	
802.11n (HT40)	MCS 0~7	1TX (Fixed Chain 0)	2RX
	MCS 8~15*	2TX	
802.11ac (VHT20)	MCS0~8 (256QAM) Nss=1	1TX (Fixed Chain 0)	2RX
	MCS0~8 (256QAM) Nss=2*	2TX	
802.11ac (VHT40)	MCS0~9 (256QAM) Nss=1	1TX (Fixed Chain 0)	2RX
	MCS0~9 (256QAM) Nss=2*	2TX	
802.11ac (VHT80)	MCS0~9 (256QAM) Nss=1	1TX (Fixed Chain 0)	2RX
	MCS0~9 (256QAM) Nss=2*	2TX	

Note: "\*" means the device operate with two spatial stream (Nss = 2) with different data, and two signals are not correlated.

- The above EUT information is declared by manufacturer and for more detailed features description, please refer to the manufacturer's specifications or user's manual.



### 3.2 Description of Test Modes

11 channels are provided for 802.11b, 802.11g and 802.11n (HT20):

Channel	Frequency (MHz)	Channel	Frequency (MHz)
1	2412	7	2442
2	2417	8	2447
3	2422	9	2452
4	2427	10	2457
5	2432	11	2462
6	2437		

7 channels are provided for 802.11n (HT40):

Channel	Frequency (MHz)	Channel	Frequency (MHz)
3	2422	7	2442
4	2427	8	2447
5	2432	9	2452
6	2437		

### 3.2.1 Test Mode Applicability and Tested Channel Detail

EUT CONFIGURE MODE	APPLICABLE TO				DESCRIPTION
	RE $\geq$ 1G	RE $<$ 1G	PLC	APCM	
1	√	√	√	√	2TX mode
2	√	√	-	√	1TX mode

Where **RE $\geq$ 1G**: Radiated Emission above 1GHz & Bandedge Measurement **RE $<$ 1G**: Radiated Emission below 1GHz

**PLC**: Power Line Conducted Emission **APCM**: Antenna Port Conducted Measurement

Note: The EUT had been pre-tested on the positioned of each 3 axis. The worst case was found when positioned on **Y-plane (below 1GHz) and X-plane (above 1GHz)**.

#### **Radiated Emission Test (Above 1GHz):**

- Pre-Scan has been conducted to determine the worst-case mode from all possible combinations between available modulations, data rates and antenna ports (if EUT with antenna diversity architecture).
- Following channel(s) was (were) selected for the final test as listed below.

2TX Mode					
MODE	AVAILABLE CHANNEL	TESTED CHANNEL	MODULATION TECHNOLOGY	MODULATION TYPE	DATA RATE (Mbps)
802.11n (HT20)	1 to 11	1, 6, 11	OFDM	BPSK	13
802.11n (HT40)	3 to 9	3, 6, 9	OFDM	BPSK	27
1TX Mode					
MODE	AVAILABLE CHANNEL	TESTED CHANNEL	MODULATION TECHNOLOGY	MODULATION TYPE	DATA RATE (Mbps)
802.11b	1 to 11	1, 6, 11	DSSS	DBPSK	1
802.11g	1 to 11	1, 6, 11	OFDM	BPSK	6
802.11n (HT20)	1 to 11	1, 6, 11	OFDM	BPSK	6.5
802.11n (HT40)	3 to 9	3, 6, 9	OFDM	BPSK	13.5

#### **Radiated Emission Test (Below 1GHz):**

- Pre-Scan has been conducted to determine the worst-case mode from all possible combinations between available modulations, data rates and antenna ports (if EUT with antenna diversity architecture).
- Following channel(s) was (were) selected for the final test as listed below.

2TX Mode					
MODE	AVAILABLE CHANNEL	TESTED CHANNEL	MODULATION TECHNOLOGY	MODULATION TYPE	DATA RATE (Mbps)
802.11n (HT20)	1 to 11	6	OFDM	BPSK	13
1TX Mode					
MODE	AVAILABLE CHANNEL	TESTED CHANNEL	MODULATION TECHNOLOGY	MODULATION TYPE	DATA RATE (Mbps)
802.11b	1 to 11	6	DSSS	DBPSK	1

### Power Line Conducted Emission Test:

- Pre-Scan has been conducted to determine the worst-case mode from all possible combinations between available modulations, data rates and antenna ports (if EUT with antenna diversity architecture).
- Following channel(s) was (were) selected for the final test as listed below.

2TX Mode					
MODE	AVAILABLE CHANNEL	TESTED CHANNEL	MODULATION TECHNOLOGY	MODULATION TYPE	DATA RATE (Mbps)
802.11n (HT20)	1 to 11	6	OFDM	BPSK	13

### Antenna Port Conducted Measurement:

- This item includes all test value of each mode, but only includes spectrum plot of worst value of each mode.
- Pre-Scan has been conducted to determine the worst-case mode from all possible combinations between available modulations, data rates and antenna ports (if EUT with antenna diversity architecture).
- Following channel(s) was (were) selected for the final test as listed below.

2TX Mode					
MODE	AVAILABLE CHANNEL	TESTED CHANNEL	MODULATION TECHNOLOGY	MODULATION TYPE	DATA RATE (Mbps)
802.11n (HT20)	1 to 11	1, 6, 11	OFDM	BPSK	13
802.11n (HT40)	3 to 9	3, 6, 9	OFDM	BPSK	27
1TX Mode					
MODE	AVAILABLE CHANNEL	TESTED CHANNEL	MODULATION TECHNOLOGY	MODULATION TYPE	DATA RATE (Mbps)
802.11b	1 to 11	1, 6, 11	DSSS	DBPSK	1
802.11g	1 to 11	1, 6, 11	OFDM	BPSK	6
802.11n (HT20)	1 to 11	1, 6, 11	OFDM	BPSK	6.5
802.11n (HT40)	3 to 9	3, 6, 9	OFDM	BPSK	13.5

### Test Condition:

APPLICABLE TO	ENVIRONMENTAL CONDITIONS	INPUT POWER (System)	TESTED BY
RE $\geq$ 1G	25deg. C, 75%RH	120Vac, 60Hz	Nelson Teng
RE $<$ 1G	25deg. C, 65%RH	120Vac, 60Hz	Nelson Teng
PLC	25deg. C, 62%RH	120Vac, 60Hz	Sampson Chen
APCM	25deg. C, 60%RH	120Vac, 60Hz	Jyunchun Lin

### 3.3 Duty Cycle of Test Signal

Duty cycle of test signal is 100 %, duty factor is not required.

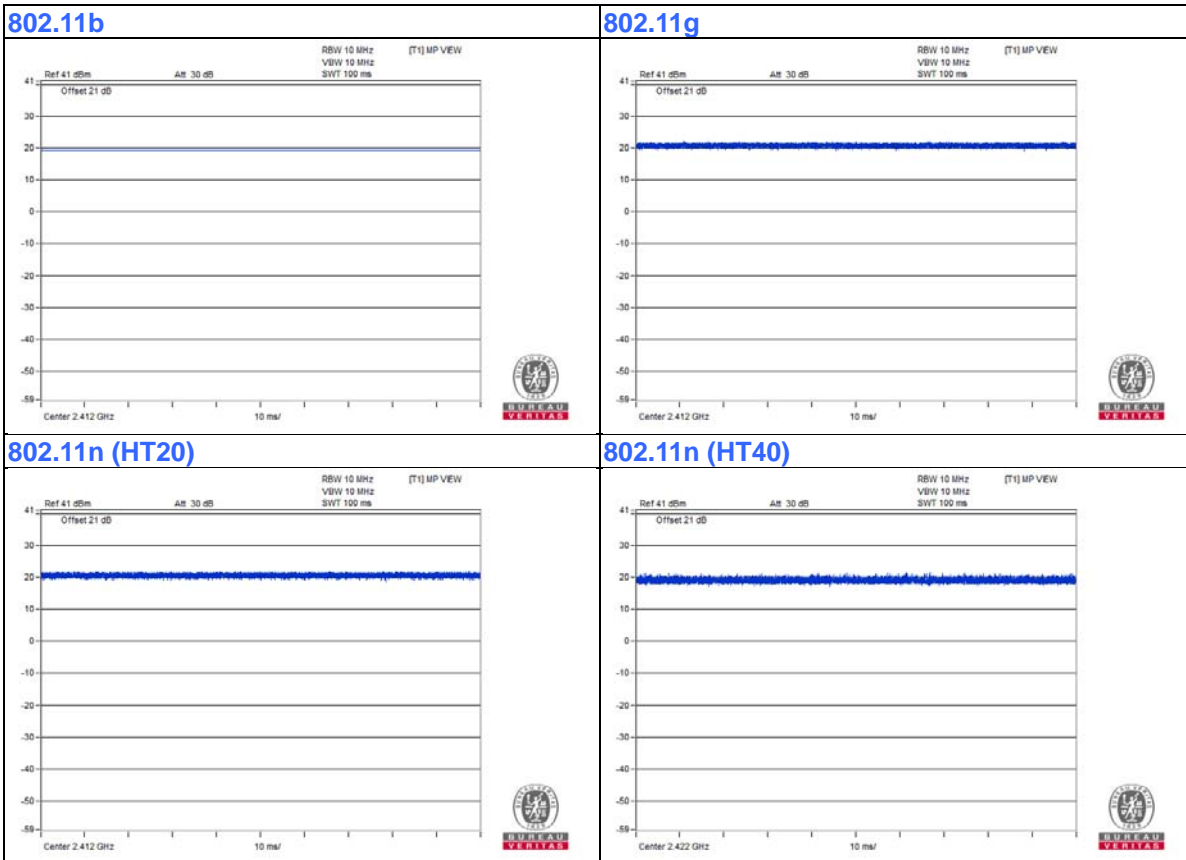

### 3.4 Description of Support Units

The EUT has been tested as an independent unit together with other necessary accessories or support units. The following support units or accessories were used to form a representative test configuration during the tests.

ID	Product	Brand	Model No.	Serial No.	FCC ID	Remarks
A.	Adapter	PHIHONG	PSC15A-050	NA	NA	Supplied by client
B.	Test Tool	MediaTek Inc.	NA	NA	NA	Supplied by client
C.	Laptop	DELL	E5430	GM1SKV1	FCC DoC	Supplied by Lab
D.	ADAPTER	MICROSOFT	M1096761-001	NA	NA	Supplied by client

Note:

1. All power cords of the above support units are non-shielded (1.8m).

ID	Descriptions	Qty.	Length (m)	Shielding (Yes/No)	Cores (Qty.)	Remarks
1.	USB Type B Cable	1	1.8	Yes	0	Provided by Lab
2.	DC Cable	1	1.5	No	0	Supplied by client

### 3.4.1 Configuration of System under Test

#### For AC Power Conducted Emissions Test:

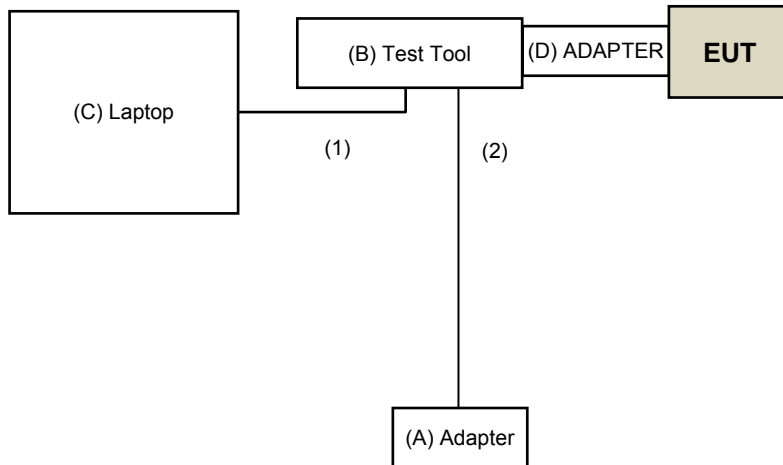

#### For Radiated Emissions Test:

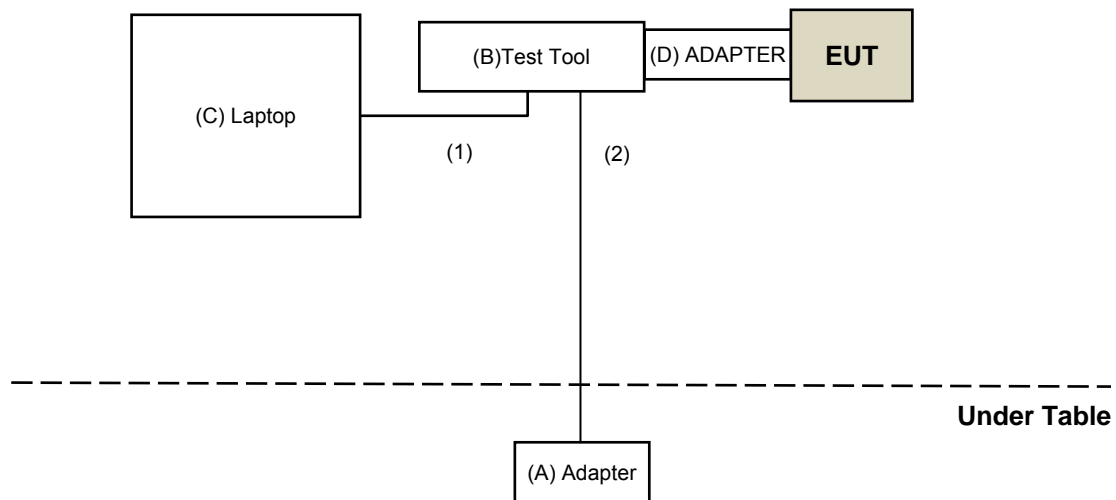

### 3.5 General Description of Applied Standards and References

The EUT is a RF Product. According to the specifications of the manufacturer, it must comply with the requirements of the following standards and references:

**Test Standard:**

**FCC Part 15, Subpart C (15.247)**

**ANSI C63.10-2013**

All test items have been performed and recorded as per the above standards.

**References Test Guidance:**

**KDB 558074 D01 15.247 Meas Guidance v05r02**

**KDB 662911 D01 Multiple Transmitter Output v02r01**

All test items have been performed as a reference to the above KDB test guidance.

## 4 Test Types and Results

### 4.1 Radiated Emission and Bandedge Measurement (Radiated Versus Conducted)

#### 4.1.1 Limits of Radiated Emission and Bandedge Measurement

Radiated emissions which fall in the restricted bands must comply with the radiated emission limits specified as below table. Other emissions shall be at least 20dB below the highest level of the desired power:

Frequencies (MHz)	Field Strength (microvolts/meter)	Measurement Distance (meters)
0.009 ~ 0.490	2400/F(kHz)	300
0.490 ~ 1.705	24000/F(kHz)	30
1.705 ~ 30.0	30	30
30 ~ 88	100	3
88 ~ 216	150	3
216 ~ 960	200	3
Above 960	500	3

**Note:**

1. The lower limit shall apply at the transition frequencies.
2. Emission level (dBuV/m) = 20 log Emission level (uV/m).
3. For frequencies above 1000MHz, the field strength limits are based on average detector, however, the peak field strength of any emission shall not exceed the maximum permitted average limits, specified above by more than 20dB under any condition of modulation.



## 4.1.2 Test Instruments

**For Radiated Emission Test:**

DESCRIPTION & MANUFACTURER	MODEL NO.	SERIAL NO.	CALIBRATED DATE	CALIBRATED UNTIL
Test Receiver Keysight	N9038A	MY54450088	July 03, 2019	July 02, 2020
Pre-Amplifier EMCI	EMC001340	980142	May 30, 2019	May 29, 2020
Loop Antenna Electro-Metrics	EM-6879	264	Feb. 18, 2020	Feb. 17, 2021
RF Cable	NA	LOOPCAB-001	Jan. 08, 2020	Jan. 07, 2021
RF Cable	NA	LOOPCAB-002	Jan. 08, 2020	Jan. 07, 2021
Pre-Amplifier Mini-Circuits	ZFL-1000VH2B	AMP-ZFL-05	Apr. 30, 2019	Apr. 29, 2020
Trilog Broadband Antenna SCHWARZBECK	VULB 9168	9168-361	Nov. 11, 2019	Nov. 10, 2020
RF Cable	8D	966-3-1	Mar. 17, 2020	Mar. 16, 2021
RF Cable	8D	966-3-2	Mar. 17, 2020	Mar. 16, 2021
RF Cable	8D	966-3-3	Mar. 17, 2020	Mar. 16, 2021
Fixed attenuator Mini-Circuits	UNAT-5+	PAD-3m-3-01	Sep. 26, 2019	Sep. 25, 2020
Horn_Antenna SCHWARZBECK	BBHA9120-D	9120D-406	Nov. 24, 2019	Nov. 23, 2020
Pre-Amplifier EMCI	EMC12630SE	980384	Jan. 15, 2020	Jan. 14, 2021
RF Cable	EMC104-SM-SM-1200	160922	Jan. 15, 2020	Jan. 14, 2021
RF Cable	EMC104-SM-SM-2000	180601	June 10, 2019	June 09, 2020
RF Cable	EMC104-SM-SM-6000	180602	June 10, 2019	June 09, 2020
Spectrum Analyzer Keysight	N9030A	MY54490679	July 17, 2019	July 16, 2020
Pre-Amplifier EMCI	EMC184045SE	980387	Jan. 15, 2020	Jan. 14, 2021
Horn_Antenna SCHWARZBECK	BBHA 9170	BBHA9170519	Nov. 24, 2019	Nov. 23, 2020
RF Cable	EMC102-KM-KM-1200	160924	Jan. 15, 2020	Jan. 14, 2021
RF Cable	EMC-KM-KM-4000	200214	Mar. 11, 2020	Mar. 10, 2021
Software	ADT_Radiated_V8.7.08	NA	NA	NA
Antenna Tower & Turn Table Max-Full	MF-7802	MF780208406	NA	NA
Boresight Antenna Fixture	FBA-01	FBA-SIP01	NA	NA
High pass filter Wainwright Instruments	WHK3.1/18G-10SS	SN5	Apr. 29, 2019	Apr. 28, 2020

**Note:**

1. The calibration interval of the above test instruments is 12 months and the calibrations are traceable to NML/ROC and NIST/USA.
2. The test was performed in 966 Chamber No. 3.
3. Loop antenna was used for all emissions below 30 MHz.
4. Tested Date: Mar. 23 to 25, 2020

**For other test items:**

DESCRIPTION & MANUFACTURER	MODEL NO.	SERIAL NO.	CALIBRATED DATE	CALIBRATED UNTIL
Spectrum Analyzer R&S	FSV40	100964	June 04, 2019	June 03, 2020
Power meter Anritsu	ML2495A	1529002	July 26, 2019	July 25, 2020
Power sensor Anritsu	MA2411B	1339443	July 26, 2019	July 25, 2020
Fixed Attenuator Mini-Circuits	MDCS18N-10	MDCS18N-10-01	Apr. 14, 2020	Apr. 13, 2021
Software	ADT_RF Test Software V6.6.5.4	NA	NA	NA

- NOTE:**
1. The test was performed in Oven room 2.
  2. The calibration interval of the above test instruments is 12 months and the calibrations are traceable to NML/ROC and NIST/USA.
  3. Tested Date: May 19, 2020

#### 4.1.3 Test Procedures

Following FCC KDB 558074 D01 DTS Meas Guidance:

Radiated versus Conducted Measurements.

The unwanted emission limits in both the restricted and non-restricted bands are based on antenna-port conducted measurements in conjunction with cabinet emissions tests are permitted to demonstrate compliance.

The following steps was performed:

- a. Cabinet emissions measurements. Radiated measurement was performed to ensure that cabinet emissions are below the emission limits. For the cabinet-emission measurements the antenna was replaced by a termination matching the nominal impedance of the antenna.
- b. Conducted tests was performed using equipment that matches the nominal impedance of the antenna assembly used with the EUT
- c. EIRP calculation. A value representative of an upper bound on out-of-band antenna gain (in dBi) shall be added to the measured antenna-port conducted emission power to compute EIRP within the specified measurement bandwidth. (For emissions in the restricted bands, additional calculations are required to convert EIRP to field strength at the specified distance.) The upper bound on antenna gain for a device with a single RF output shall be selected as the maximum in-band gain of the antenna across all operating bands or 2 dBi, whichever is greater
- d. EIRP adjustments for multiple outputs. (Follow the procedures specified in FCC KDB Publication 662911)
- e. For all of Radiation emission test

##### **For Radiated emission below 30MHz**

- e-1.1. The EUT was placed on the top of a rotating table 0.8 meters above the ground at a 3 meter chamber room. The table was rotated 360 degrees to determine the position of the highest radiation.
- e-1.2. The EUT was set 3 meters away from the interference-receiving antenna, which was mounted on the top of a variable-height antenna tower.
- e-1.3. Parallel, perpendicular, and ground-parallel orientations of the antenna are set to make the measurement.
- e-1.4. For each suspected emission, the EUT was arranged to its worst case and the rotatable table was turned from 0 degrees to 360 degrees to find the maximum reading.
- e-1.5. The test-receiver system was set to Quasi-Peak Detect Function and Specified Bandwidth with Maximum Hold Mode.

##### **Note:**

1. The resolution bandwidth and video bandwidth of test receiver/spectrum analyzer is 9kHz at frequency below 30MHz.
2. KDB 414788 OATS and Chamber Correlation Justification
  - Based on FCC 15.31(f)(2) : measurements may be performed at a distance closer than that specified in the regulations; however, an attempts should be made to avoid making measurements in the near field.
  - OATs and chamber correlation testing had been performed and chamber measured test result is the worst case test result.

### For Radiated emission above 30MHz

- e-2.1. The EUT was placed on the top of a rotating table 0.8 meters (for 30MHz ~ 1GHz) / 1.5 meters (for above 1GHz) above the ground at 3 meter chamber room for test. The table was rotated 360 degrees to determine the position of the highest radiation.
- e-2.2. The EUT was set 3 meters away from the interference-receiving antenna, which was mounted on the top of a variable-height antenna tower.
- e-2.3. The height of antenna is varied from one meter to four meters above the ground to determine the maximum value of the field strength. Both horizontal and vertical polarizations of the antenna are set to make the measurement.
- e-2.4. For each suspected emission, the EUT was arranged to its worst case and then the antenna was tuned to heights from 1 meter to 4 meters and the rotatable table was turned from 0 degrees to 360 degrees to find the maximum reading.
- e-2.5. The test-receiver system was set to quasi-peak detect function and specified bandwidth with maximum hold mode when the test frequency is below 1 GHz.
- e-2.6. The test-receiver system was set to peak and average detects function and specified bandwidth with maximum hold mode when the test frequency is above 1 GHz. If the peak reading value also meets average limit, measurement with the average detector is unnecessary.

#### Note:

1. The resolution bandwidth and video bandwidth of test receiver/spectrum analyzer is 120kHz for Quasi-peak detection (QP) at frequency below 1GHz.
2. The resolution bandwidth of test receiver/spectrum analyzer is 1 MHz and the video bandwidth is 3 MHz for Peak detection (PK) at frequency above 1GHz.
3. The resolution bandwidth of test receiver/spectrum analyzer is 1MHz and the video bandwidth is  $\geq 1/T$  (Duty cycle < 98%) or 10Hz (Duty cycle  $\geq$  98%) for Average detection (AV) at frequency above 1GHz.
4. All modes of operation were investigated and the worst-case emissions are reported.

#### 4.1.4 Deviation from Test Standard

No deviation.

#### 4.1.5 Test Setup

**For Radiated Configuration:  
For Radiated emission below 30MHz**

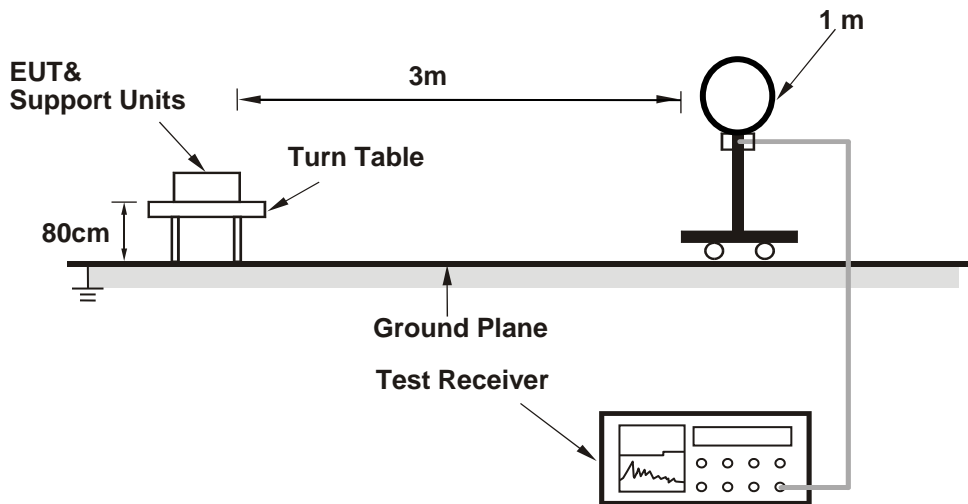

**For Radiated emission 30MHz to 1GHz**

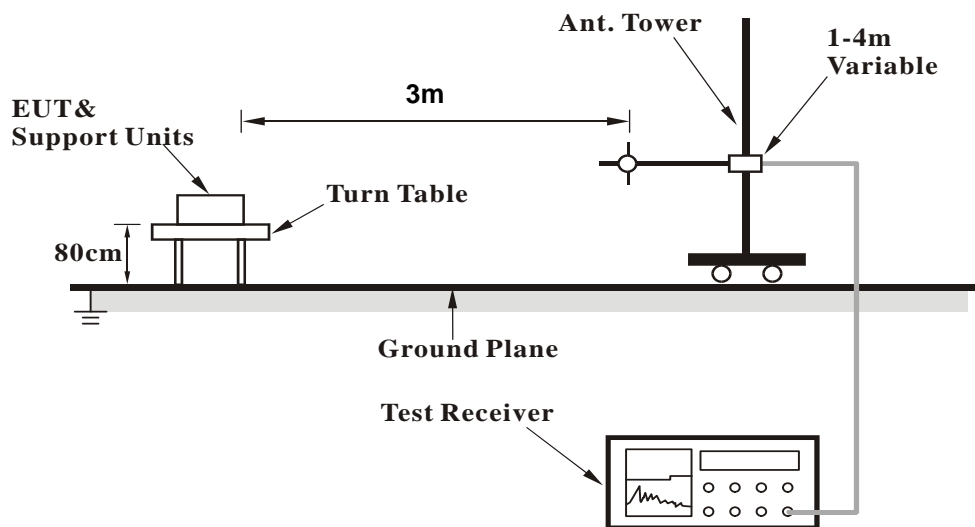

**For Radiated emission above 1GHz**

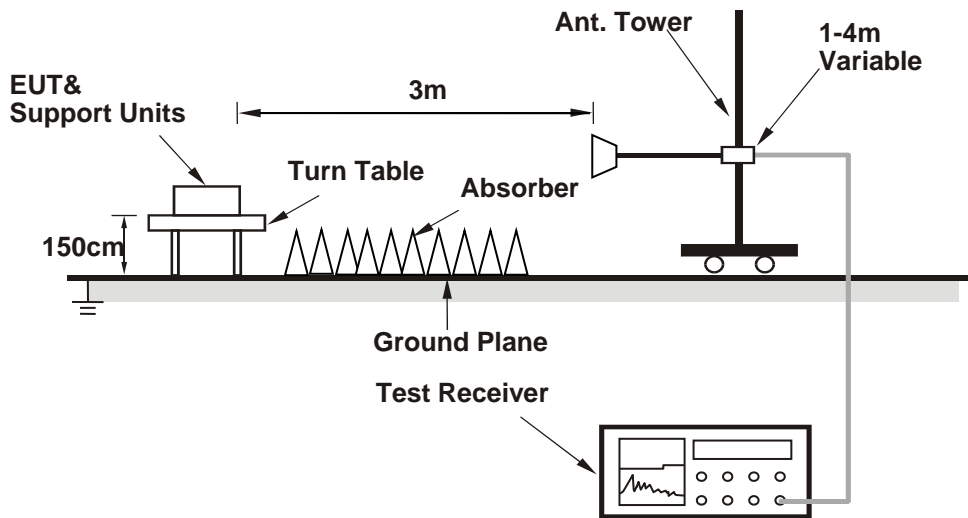

**For Conducted Configuration:**

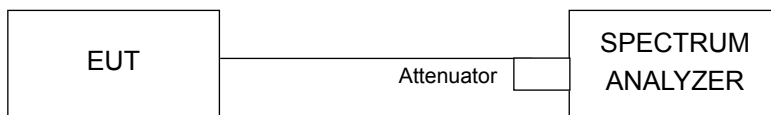

For the actual test configuration, please refer to the attached file (Test Setup Photo).

**4.1.6 EUT Operating Conditions**

- a. Connected the EUT with the Laptop which is placed on the testing table.
- b. Controlling software (MT7663 QA 0.0.2.6) has been activated to set the EUT under transmission condition continuously at specific channel frequency.

#### 4.1.7 Test Results (Radiated Measurement)

Radiated versus Conducted Measurement	
<input type="checkbox"/> Conducted measurement	<input checked="" type="checkbox"/> Radiated measurement
<u>For Radiated measurement:</u> The level of unwanted emissions was measured when radiated by the cabinet or structure of the equipment with the antenna connector(s) terminated by a specified load (cabinet radiation)	
<u>For Conducted measurement:</u> The level of unwanted emissions was measured as their power in a specified load (conducted spurious emissions).	

4.1.7.1 Test Results (Mode 1)

Radiated test was done with 50ohm terminator on antenna port

Above 1GHz Data:

802.11n (HT20)

<b>CHANNEL</b>	TX Channel 1	<b>DETECTOR FUNCTION</b>	Peak (PK)
<b>FREQUENCY RANGE</b>	1GHz ~ 25GHz		Average (AV)

ANTENNA POLARITY & TEST DISTANCE: HORIZONTAL AT 3 M								
NO.	FREQ. (MHz)	EMISSION LEVEL (dBuV/m)	LIMIT (dBuV/m)	MARGIN (dB)	ANTENNA HEIGHT (m)	TABLE ANGLE (Degree)	RAW VALUE (dBuV)	CORRECTION FACTOR (dB/m)
1	4824.00	37.9 PK	74.0	-36.1	1.11 H	290	35.0	2.9
2	4824.00	25.4 AV	54.0	-28.6	1.11 H	290	22.5	2.9

**REMARKS:**

1. Emission Level(dBuV/m) = Raw Value(dBuV) + Correction Factor(dB/m)
2. Correction Factor(dB/m) = Antenna Factor(dB/m) + Cable Factor(dB) – Pre-Amplifier Factor(dB)
3. Margin value = Emission Level – Limit value
4. The other emission levels were very low against the limit.

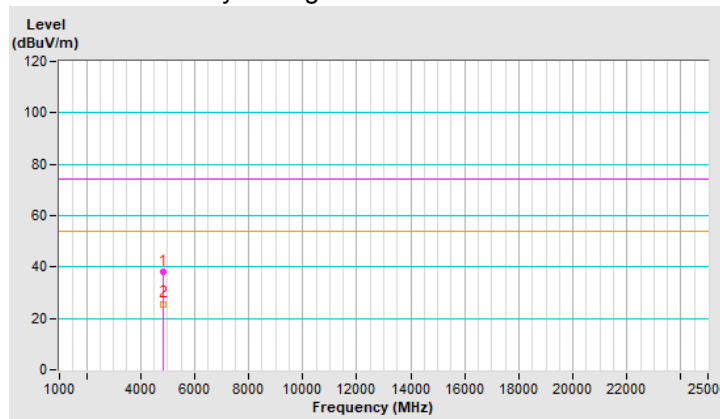



<b>CHANNEL</b>	TX Channel 1	<b>DETECTOR FUNCTION</b>	Peak (PK)
<b>FREQUENCY RANGE</b>	1GHz ~ 25GHz		Average (AV)

ANTENNA POLARITY & TEST DISTANCE: VERTICAL AT 3 M								
NO.	FREQ. (MHz)	EMISSION LEVEL (dBuV/m)	LIMIT (dBuV/m)	MARGIN (dB)	ANTENNA HEIGHT (m)	TABLE ANGLE (Degree)	RAW VALUE (dBuV)	CORRECTION FACTOR (dB/m)
1	4824.00	38.0 PK	74.0	-36.0	1.62 V	104	35.1	2.9
2	4824.00	25.7 AV	54.0	-28.3	1.62 V	104	22.8	2.9

**REMARKS:**

1. Emission Level(dBuV/m) = Raw Value(dBuV) + Correction Factor(dB/m)
2. Correction Factor(dB/m) = Antenna Factor(dB/m) + Cable Factor(dB) – Pre-Amplifier Factor(dB)
3. Margin value = Emission Level – Limit value
4. The other emission levels were very low against the limit.

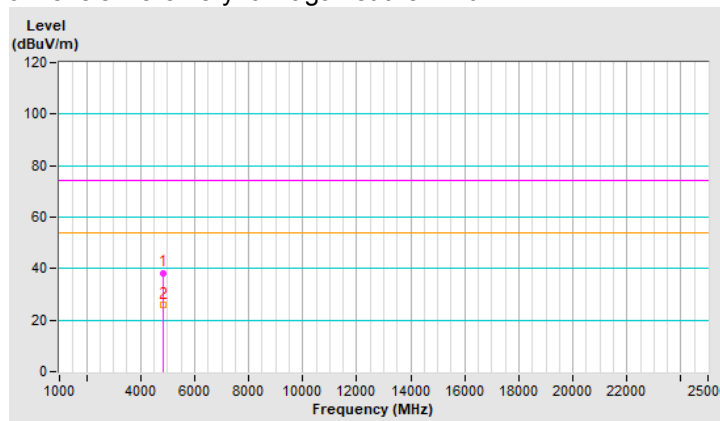

<b>CHANNEL</b>	TX Channel 6	<b>DETECTOR FUNCTION</b>	Peak (PK)
<b>FREQUENCY RANGE</b>	1GHz ~ 25GHz		Average (AV)

**ANTENNA POLARITY & TEST DISTANCE: HORIZONTAL AT 3 M**

NO.	FREQ. (MHz)	EMISSION LEVEL (dBuV/m)	LIMIT (dBuV/m)	MARGIN (dB)	ANTENNA HEIGHT (m)	TABLE ANGLE (Degree)	RAW VALUE (dBuV)	CORRECTION FACTOR (dB/m)
1	4874.00	37.6 PK	74.0	-36.4	1.11 H	280	34.8	2.8
2	4874.00	25.2 AV	54.0	-28.8	1.11 H	280	22.4	2.8
3	7311.00	42.4 PK	74.0	-31.6	1.43 H	14	33.5	8.9
4	7311.00	30.3 AV	54.0	-23.7	1.43 H	14	21.4	8.9

**REMARKS:**

1. Emission Level(dBuV/m) = Raw Value(dBuV) + Correction Factor(dB/m)
2. Correction Factor(dB/m) = Antenna Factor(dB/m) + Cable Factor(dB) – Pre-Amplifier Factor(dB)
3. Margin value = Emission Level – Limit value
4. The other emission levels were very low against the limit.

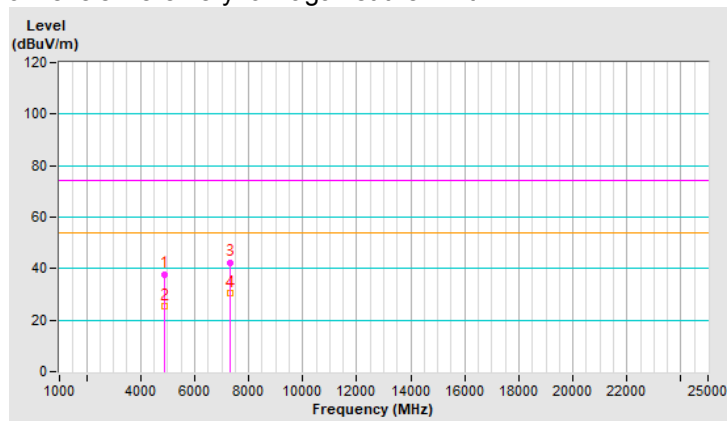

<b>CHANNEL</b>	TX Channel 6	<b>DETECTOR FUNCTION</b>	Peak (PK)
<b>FREQUENCY RANGE</b>	1GHz ~ 25GHz		Average (AV)

ANTENNA POLARITY & TEST DISTANCE: VERTICAL AT 3 M								
NO.	FREQ. (MHz)	EMISSION LEVEL (dBuV/m)	LIMIT (dBuV/m)	MARGIN (dB)	ANTENNA HEIGHT (m)	TABLE ANGLE (Degree)	RAW VALUE (dBuV)	CORRECTION FACTOR (dB/m)
1	4874.00	37.6 PK	74.0	-36.4	1.61 V	120	34.8	2.8
2	4874.00	25.3 AV	54.0	-28.7	1.61 V	120	22.5	2.8
3	7311.00	42.9 PK	74.0	-31.1	1.32 V	121	34.0	8.9
4	7311.00	30.7 AV	54.0	-23.3	1.32 V	121	21.8	8.9

**REMARKS:**

1. Emission Level(dBuV/m) = Raw Value(dBuV) + Correction Factor(dB/m)
2. Correction Factor(dB/m) = Antenna Factor(dB/m) + Cable Factor(dB) – Pre-Amplifier Factor(dB)
3. Margin value = Emission Level – Limit value
4. The other emission levels were very low against the limit.

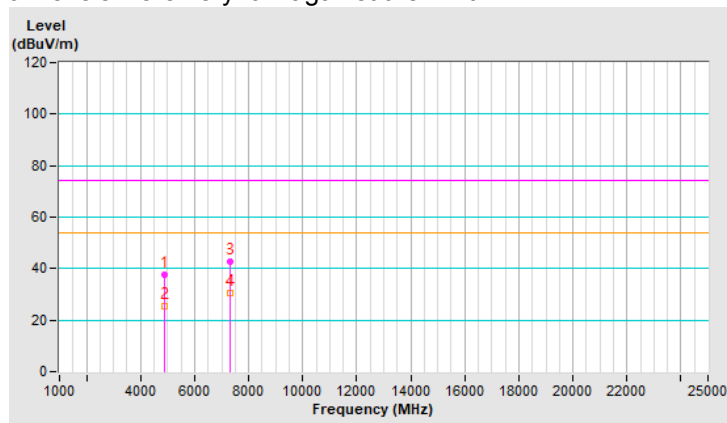

<b>CHANNEL</b>	TX Channel 11	<b>DETECTOR FUNCTION</b>	Peak (PK)
<b>FREQUENCY RANGE</b>	1GHz ~ 25GHz		Average (AV)

**ANTENNA POLARITY & TEST DISTANCE: HORIZONTAL AT 3 M**

NO.	FREQ. (MHz)	EMISSION LEVEL (dBuV/m)	LIMIT (dBuV/m)	MARGIN (dB)	ANTENNA HEIGHT (m)	TABLE ANGLE (Degree)	RAW VALUE (dBuV)	CORRECTION FACTOR (dB/m)
1	4924.00	37.7 PK	74.0	-36.3	1.15 H	280	35.0	2.7
2	4924.00	25.0 AV	54.0	-29.0	1.15 H	280	22.3	2.7
3	7386.00	42.1 PK	74.0	-31.9	1.38 H	18	33.1	9.0
4	7386.00	30.2 AV	54.0	-23.8	1.38 H	18	21.2	9.0

**REMARKS:**

1. Emission Level(dBuV/m) = Raw Value(dBuV) + Correction Factor(dB/m)
2. Correction Factor(dB/m) = Antenna Factor(dB/m) + Cable Factor(dB) – Pre-Amplifier Factor(dB)
3. Margin value = Emission Level – Limit value
4. The other emission levels were very low against the limit.

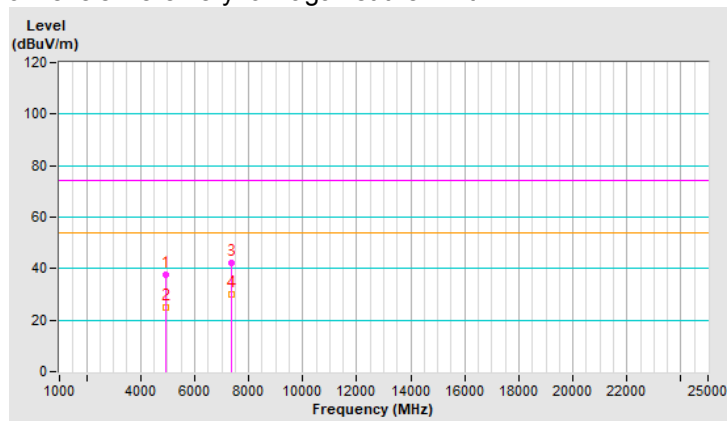

<b>CHANNEL</b>	TX Channel 11	<b>DETECTOR FUNCTION</b>	Peak (PK)
<b>FREQUENCY RANGE</b>	1GHz ~ 25GHz		Average (AV)

ANTENNA POLARITY & TEST DISTANCE: VERTICAL AT 3 M								
NO.	FREQ. (MHz)	EMISSION LEVEL (dBuV/m)	LIMIT (dBuV/m)	MARGIN (dB)	ANTENNA HEIGHT (m)	TABLE ANGLE (Degree)	RAW VALUE (dBuV)	CORRECTION FACTOR (dB/m)
1	4924.00	37.7 PK	74.0	-36.3	1.55 V	126	35.0	2.7
2	4924.00	25.6 AV	54.0	-28.4	1.55 V	126	22.9	2.7
3	7386.00	42.3 PK	74.0	-31.7	1.26 V	105	33.3	9.0
4	7386.00	30.3 AV	54.0	-23.7	1.26 V	105	21.3	9.0

**REMARKS:**

1. Emission Level(dBuV/m) = Raw Value(dBuV) + Correction Factor(dB/m)
2. Correction Factor(dB/m) = Antenna Factor(dB/m) + Cable Factor(dB) – Pre-Amplifier Factor(dB)
3. Margin value = Emission Level – Limit value
4. The other emission levels were very low against the limit.

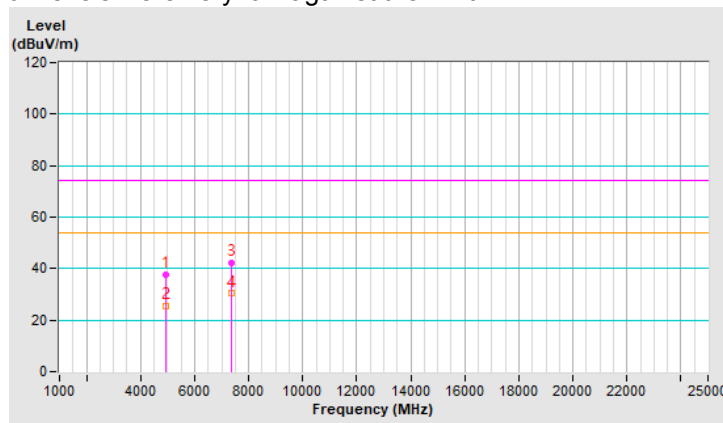

802.11n (HT40)

<b>CHANNEL</b>	TX Channel 3	<b>DETECTOR FUNCTION</b>	Peak (PK)
<b>FREQUENCY RANGE</b>	1GHz ~ 25GHz		Average (AV)

ANTENNA POLARITY & TEST DISTANCE: HORIZONTAL AT 3 M								
NO.	FREQ. (MHz)	EMISSION LEVEL (dBuV/m)	LIMIT (dBuV/m)	MARGIN (dB)	ANTENNA HEIGHT (m)	TABLE ANGLE (Degree)	RAW VALUE (dBuV)	CORRECTION FACTOR (dB/m)
1	4844.00	37.8 PK	74.0	-36.2	1.10 H	275	34.9	2.9
2	4844.00	25.4 AV	54.0	-28.6	1.10 H	275	22.5	2.9
3	7266.00	42.4 PK	74.0	-31.6	1.48 H	17	33.6	8.8
4	7266.00	30.5 AV	54.0	-23.5	1.48 H	17	21.7	8.8

**REMARKS:**

1. Emission Level(dBuV/m) = Raw Value(dBuV) + Correction Factor(dB/m)
2. Correction Factor(dB/m) = Antenna Factor(dB/m) + Cable Factor(dB) – Pre-Amplifier Factor(dB)
3. Margin value = Emission Level – Limit value
4. The other emission levels were very low against the limit.

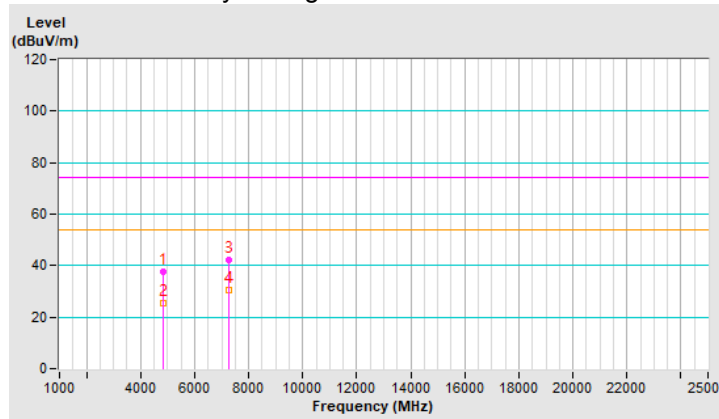

<b>CHANNEL</b>	TX Channel 3	<b>DETECTOR FUNCTION</b>	Peak (PK)
<b>FREQUENCY RANGE</b>	1GHz ~ 25GHz		Average (AV)

ANTENNA POLARITY & TEST DISTANCE: VERTICAL AT 3 M								
NO.	FREQ. (MHz)	EMISSION LEVEL (dBuV/m)	LIMIT (dBuV/m)	MARGIN (dB)	ANTENNA HEIGHT (m)	TABLE ANGLE (Degree)	RAW VALUE (dBuV)	CORRECTION FACTOR (dB/m)
1	4844.00	37.3 PK	74.0	-36.7	1.57 V	113	34.4	2.9
2	4844.00	25.1 AV	54.0	-28.9	1.57 V	113	22.2	2.9
3	7266.00	42.4 PK	74.0	-31.6	1.36 V	133	33.6	8.8
4	7266.00	30.2 AV	54.0	-23.8	1.36 V	133	21.4	8.8

**REMARKS:**

1. Emission Level(dBuV/m) = Raw Value(dBuV) + Correction Factor(dB/m)
2. Correction Factor(dB/m) = Antenna Factor(dB/m) + Cable Factor(dB) – Pre-Amplifier Factor(dB)
3. Margin value = Emission Level – Limit value
4. The other emission levels were very low against the limit.

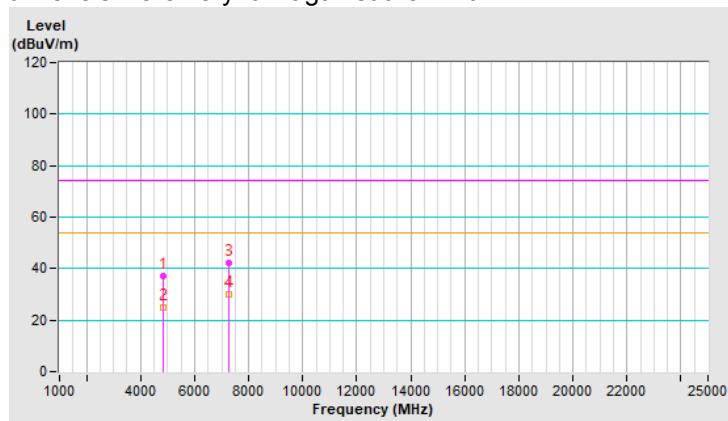

<b>CHANNEL</b>	TX Channel 6	<b>DETECTOR FUNCTION</b>	Peak (PK)
<b>FREQUENCY RANGE</b>	1GHz ~ 25GHz		Average (AV)

**ANTENNA POLARITY & TEST DISTANCE: HORIZONTAL AT 3 M**

NO.	FREQ. (MHz)	EMISSION LEVEL (dBuV/m)	LIMIT (dBuV/m)	MARGIN (dB)	ANTENNA HEIGHT (m)	TABLE ANGLE (Degree)	RAW VALUE (dBuV)	CORRECTION FACTOR (dB/m)
1	4874.00	37.4 PK	74.0	-36.6	1.09 H	265	34.6	2.8
2	4874.00	24.9 AV	54.0	-29.1	1.09 H	265	22.1	2.8
3	7311.00	43.1 PK	74.0	-30.9	1.40 H	10	34.2	8.9
4	7311.00	30.7 AV	54.0	-23.3	1.40 H	10	21.8	8.9

**REMARKS:**

1. Emission Level(dBuV/m) = Raw Value(dBuV) + Correction Factor(dB/m)
2. Correction Factor(dB/m) = Antenna Factor(dB/m) + Cable Factor(dB) – Pre-Amplifier Factor(dB)
3. Margin value = Emission Level – Limit value
4. The other emission levels were very low against the limit.

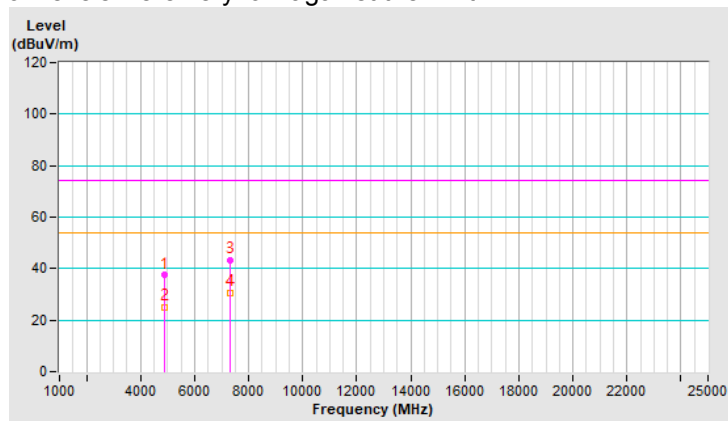



<b>CHANNEL</b>	TX Channel 6	<b>DETECTOR FUNCTION</b>	Peak (PK)
<b>FREQUENCY RANGE</b>	1GHz ~ 25GHz		Average (AV)

ANTENNA POLARITY & TEST DISTANCE: VERTICAL AT 3 M								
NO.	FREQ. (MHz)	EMISSION LEVEL (dBuV/m)	LIMIT (dBuV/m)	MARGIN (dB)	ANTENNA HEIGHT (m)	TABLE ANGLE (Degree)	RAW VALUE (dBuV)	CORRECTION FACTOR (dB/m)
1	4874.00	37.2 PK	74.0	-36.8	1.59 V	117	34.4	2.8
2	4874.00	24.9 AV	54.0	-29.1	1.59 V	117	22.1	2.8
3	7311.00	42.8 PK	74.0	-31.2	1.32 V	120	33.9	8.9
4	7311.00	30.8 AV	54.0	-23.2	1.32 V	120	21.9	8.9

**REMARKS:**

1. Emission Level(dBuV/m) = Raw Value(dBuV) + Correction Factor(dB/m)
2. Correction Factor(dB/m) = Antenna Factor(dB/m) + Cable Factor(dB) – Pre-Amplifier Factor(dB)
3. Margin value = Emission Level – Limit value
4. The other emission levels were very low against the limit.

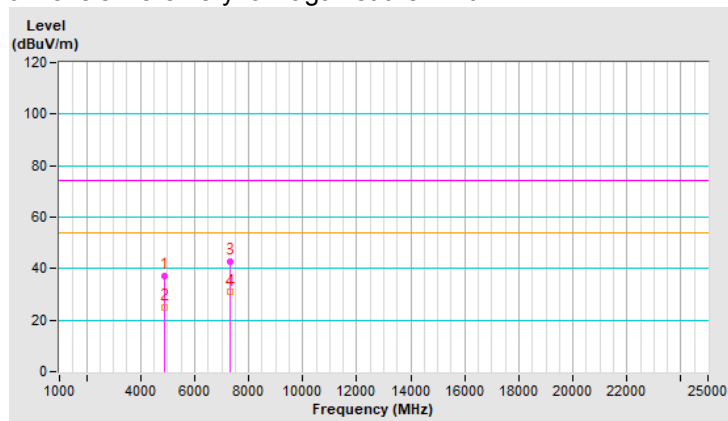

<b>CHANNEL</b>	TX Channel 9	<b>DETECTOR FUNCTION</b>	Peak (PK)
<b>FREQUENCY RANGE</b>	1GHz ~ 25GHz		Average (AV)

**ANTENNA POLARITY & TEST DISTANCE: HORIZONTAL AT 3 M**

NO.	FREQ. (MHz)	EMISSION LEVEL (dBuV/m)	LIMIT (dBuV/m)	MARGIN (dB)	ANTENNA HEIGHT (m)	TABLE ANGLE (Degree)	RAW VALUE (dBuV)	CORRECTION FACTOR (dB/m)
1	4904.00	38.1 PK	74.0	-35.9	1.14 H	276	35.4	2.7
2	4904.00	25.5 AV	54.0	-28.5	1.14 H	276	22.8	2.7
3	7356.00	42.3 PK	74.0	-31.7	1.46 H	24	33.4	8.9
4	7356.00	30.3 AV	54.0	-23.7	1.46 H	24	21.4	8.9

**REMARKS:**

1. Emission Level(dBuV/m) = Raw Value(dBuV) + Correction Factor(dB/m)
2. Correction Factor(dB/m) = Antenna Factor(dB/m) + Cable Factor(dB) – Pre-Amplifier Factor(dB)
3. Margin value = Emission Level – Limit value
4. The other emission levels were very low against the limit.

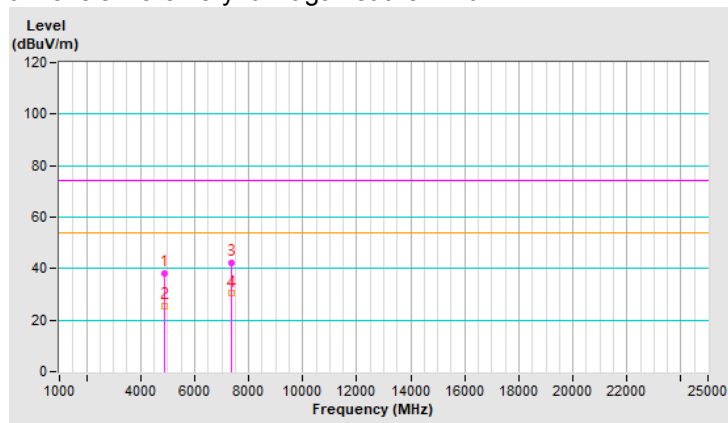

<b>CHANNEL</b>	TX Channel 9	<b>DETECTOR FUNCTION</b>	Peak (PK)
<b>FREQUENCY RANGE</b>	1GHz ~ 25GHz		Average (AV)

ANTENNA POLARITY & TEST DISTANCE: VERTICAL AT 3 M								
NO.	FREQ. (MHz)	EMISSION LEVEL (dBuV/m)	LIMIT (dBuV/m)	MARGIN (dB)	ANTENNA HEIGHT (m)	TABLE ANGLE (Degree)	RAW VALUE (dBuV)	CORRECTION FACTOR (dB/m)
1	4904.00	37.4 PK	74.0	-36.6	1.64 V	135	34.7	2.7
2	4904.00	24.9 AV	54.0	-29.1	1.64 V	135	22.2	2.7
3	7356.00	42.2 PK	74.0	-31.8	1.30 V	106	33.3	8.9
4	7356.00	30.3 AV	54.0	-23.7	1.30 V	106	21.4	8.9

**REMARKS:**

1. Emission Level(dBuV/m) = Raw Value(dBuV) + Correction Factor(dB/m)
2. Correction Factor(dB/m) = Antenna Factor(dB/m) + Cable Factor(dB) – Pre-Amplifier Factor(dB)
3. Margin value = Emission Level – Limit value
4. The other emission levels were very low against the limit.

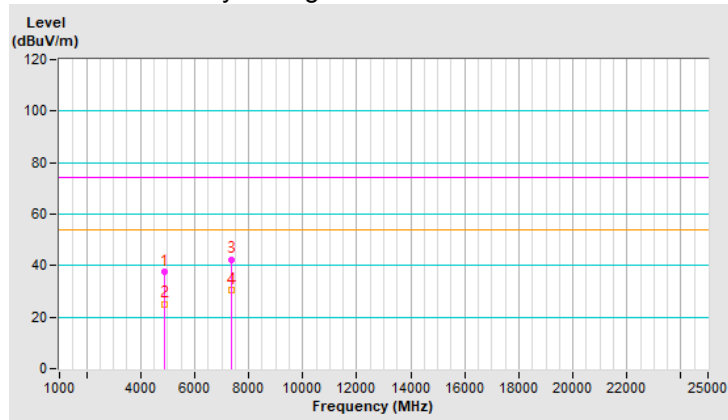

Below 1GHz Data:

802.11n (HT20)

<b>CHANNEL</b>	TX Channel 6	<b>DETECTOR FUNCTION</b>	Quasi-Peak (QP)
<b>FREQUENCY RANGE</b>	9kHz ~ 1GHz		

**ANTENNA POLARITY & TEST DISTANCE: HORIZONTAL AT 3 M**

NO.	FREQ. (MHz)	EMISSION LEVEL (dBuV/m)	LIMIT (dBuV/m)	MARGIN (dB)	ANTENNA HEIGHT (m)	TABLE ANGLE (Degree)	RAW VALUE (dBuV)	CORRECTION FACTOR (dB/m)
1	137.31	35.8 QP	43.5	-7.7	2.00 H	104	43.5	-7.7
2	166.04	37.0 QP	43.5	-6.5	1.50 H	274	44.4	-7.4
3	241.48	36.4 QP	46.0	-9.6	1.00 H	285	45.0	-8.6
4	299.32	37.6 QP	46.0	-8.4	1.00 H	285	44.0	-6.4
5	475.98	33.7 QP	46.0	-12.3	2.00 H	38	35.7	-2.0
6	715.26	38.6 QP	46.0	-7.4	1.00 H	29	35.9	2.7

**REMARKS:**

1. Emission Level(dBuV/m) = Raw Value(dBuV) + Correction Factor(dB/m)
2. Correction Factor(dB/m) = Antenna Factor(dB/m) + Cable Factor(dB) – Pre-Amplifier Factor(dB)
3. Margin value = Emission Level – Limit value
4. The other emission levels were very low against the limit of frequency range 30MHz~1000MHz.
5. The emission levels were very low against the limit of frequency range 9kHz~30MHz: the amplitude of spurious emissions attenuated more than 20 dB below the permissible value to be report.

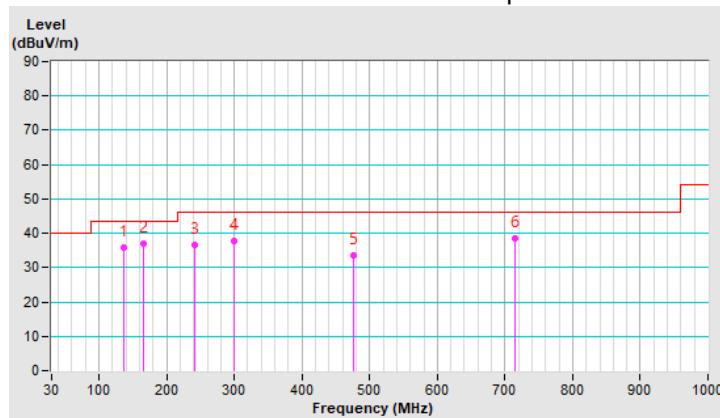

<b>CHANNEL</b>	TX Channel 6	<b>DETECTOR FUNCTION</b>	Quasi-Peak (QP)
<b>FREQUENCY RANGE</b>	9kHz ~ 1GHz		

ANTENNA POLARITY & TEST DISTANCE: VERTICAL AT 3 M								
NO.	FREQ. (MHz)	EMISSION LEVEL (dBuV/m)	LIMIT (dBuV/m)	MARGIN (dB)	ANTENNA HEIGHT (m)	TABLE ANGLE (Degree)	RAW VALUE (dBuV)	CORRECTION FACTOR (dB/m)
1	99.67	36.2 QP	43.5	-7.3	1.00 V	78	48.1	-11.9
2	165.99	32.1 QP	43.5	-11.4	1.00 V	66	39.5	-7.4
3	232.39	34.3 QP	46.0	-11.7	1.00 V	101	43.4	-9.1
4	298.74	36.2 QP	46.0	-9.8	2.00 V	187	42.6	-6.4
5	484.78	36.8 QP	46.0	-9.2	1.00 V	343	38.6	-1.8
6	716.71	37.8 QP	46.0	-8.2	2.00 V	340	35.1	2.7

**REMARKS:**

1. Emission Level(dBuV/m) = Raw Value(dBuV) + Correction Factor(dB/m)
2. Correction Factor(dB/m) = Antenna Factor(dB/m) + Cable Factor(dB) – Pre-Amplifier Factor(dB)
3. Margin value = Emission Level – Limit value
4. The other emission levels were very low against the limit of frequency range 30MHz~1000MHz.
5. The emission levels were very low against the limit of frequency range 9kHz~30MHz: the amplitude of spurious emissions attenuated more than 20 dB below the permissible value to be report.

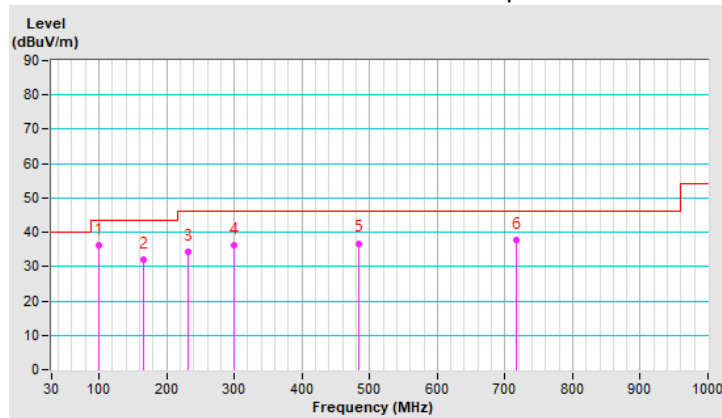

4.1.7.2 Test Results (Mode 2)

Radiated test was done with 50ohm terminator on antenna port

Above 1GHz Data:

802.11b

<b>CHANNEL</b>	TX Channel 1	<b>DETECTOR FUNCTION</b>	Peak (PK)
<b>FREQUENCY RANGE</b>	1GHz ~ 25GHz		Average (AV)

ANTENNA POLARITY & TEST DISTANCE: HORIZONTAL AT 3 M								
NO.	FREQ. (MHz)	EMISSION LEVEL (dBuV/m)	LIMIT (dBuV/m)	MARGIN (dB)	ANTENNA HEIGHT (m)	TABLE ANGLE (Degree)	RAW VALUE (dBuV)	CORRECTION FACTOR (dB/m)
1	4824.00	38.2 PK	74.0	-35.8	1.13 H	309	35.3	2.9
2	4824.00	25.6 AV	54.0	-28.4	1.13 H	309	22.7	2.9

REMARKS:

1. Emission Level(dBuV/m) = Raw Value(dBuV) + Correction Factor(dB/m)
2. Correction Factor(dB/m) = Antenna Factor(dB/m) + Cable Factor(dB) – Pre-Amplifier Factor(dB)
3. Margin value = Emission Level – Limit value
4. The other emission levels were very low against the limit.

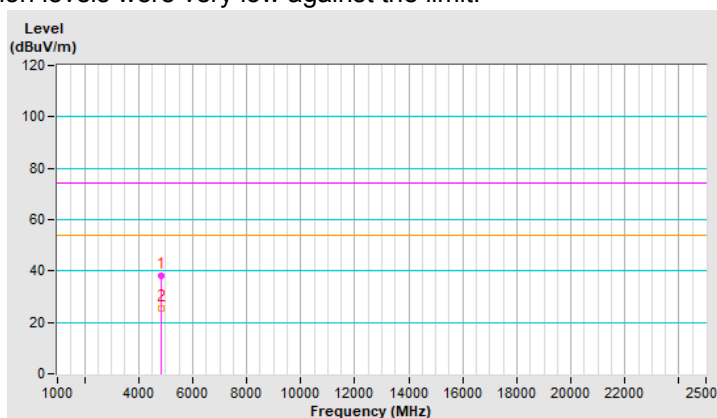

<b>CHANNEL</b>	TX Channel 1	<b>DETECTOR FUNCTION</b>	Peak (PK)
<b>FREQUENCY RANGE</b>	1GHz ~ 25GHz		Average (AV)

ANTENNA POLARITY & TEST DISTANCE: VERTICAL AT 3 M								
NO.	FREQ. (MHz)	EMISSION LEVEL (dBuV/m)	LIMIT (dBuV/m)	MARGIN (dB)	ANTENNA HEIGHT (m)	TABLE ANGLE (Degree)	RAW VALUE (dBuV)	CORRECTION FACTOR (dB/m)
1	4824.00	37.9 PK	74.0	-36.1	1.63 V	106	35.0	2.9
2	4824.00	25.7 AV	54.0	-28.3	1.63 V	106	22.8	2.9

**REMARKS:**

1. Emission Level(dBuV/m) = Raw Value(dBuV) + Correction Factor(dB/m)
2. Correction Factor(dB/m) = Antenna Factor(dB/m) + Cable Factor(dB) – Pre-Amplifier Factor(dB)
3. Margin value = Emission Level – Limit value
4. The other emission levels were very low against the limit.

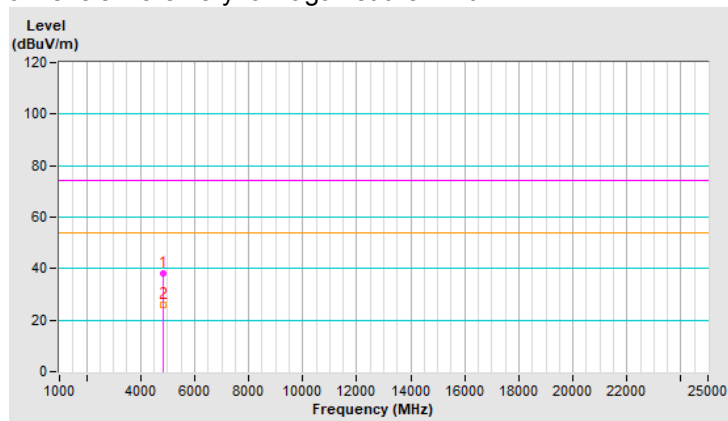

<b>CHANNEL</b>	TX Channel 6	<b>DETECTOR FUNCTION</b>	Peak (PK)
<b>FREQUENCY RANGE</b>	1GHz ~ 25GHz		Average (AV)

**ANTENNA POLARITY & TEST DISTANCE: HORIZONTAL AT 3 M**

NO.	FREQ. (MHz)	EMISSION LEVEL (dBuV/m)	LIMIT (dBuV/m)	MARGIN (dB)	ANTENNA HEIGHT (m)	TABLE ANGLE (Degree)	RAW VALUE (dBuV)	CORRECTION FACTOR (dB/m)
1	4874.00	37.6 PK	74.0	-36.4	1.12 H	296	34.8	2.8
2	4874.00	25.2 AV	54.0	-28.8	1.12 H	296	22.4	2.8
3	7311.00	42.8 PK	74.0	-31.2	1.34 H	25	33.9	8.9
4	7311.00	30.7 AV	54.0	-23.3	1.34 H	25	21.8	8.9

**REMARKS:**

1. Emission Level(dBuV/m) = Raw Value(dBuV) + Correction Factor(dB/m)
2. Correction Factor(dB/m) = Antenna Factor(dB/m) + Cable Factor(dB) – Pre-Amplifier Factor(dB)
3. Margin value = Emission Level – Limit value
4. The other emission levels were very low against the limit.

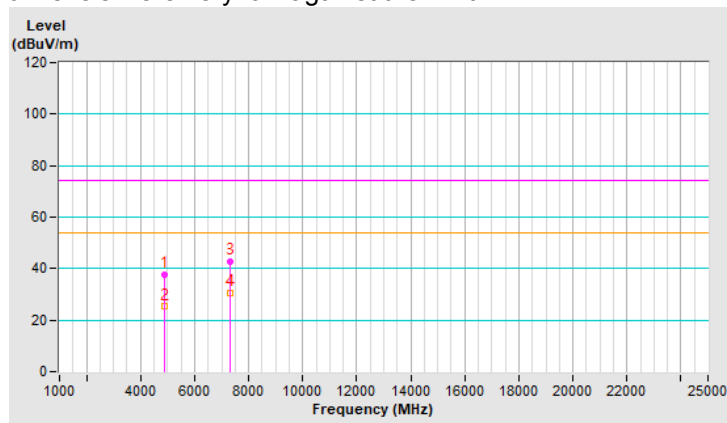



<b>CHANNEL</b>	TX Channel 6	<b>DETECTOR FUNCTION</b>	Peak (PK)
<b>FREQUENCY RANGE</b>	1GHz ~ 25GHz		Average (AV)

ANTENNA POLARITY & TEST DISTANCE: VERTICAL AT 3 M								
NO.	FREQ. (MHz)	EMISSION LEVEL (dBuV/m)	LIMIT (dBuV/m)	MARGIN (dB)	ANTENNA HEIGHT (m)	TABLE ANGLE (Degree)	RAW VALUE (dBuV)	CORRECTION FACTOR (dB/m)
1	4874.00	37.4 PK	74.0	-36.6	1.64 V	115	34.6	2.8
2	4874.00	25.1 AV	54.0	-28.9	1.64 V	115	22.3	2.8
3	7311.00	41.9 PK	74.0	-32.1	1.42 V	97	33.0	8.9
4	7311.00	30.0 AV	54.0	-24.0	1.42 V	97	21.1	8.9

**REMARKS:**

1. Emission Level(dBuV/m) = Raw Value(dBuV) + Correction Factor(dB/m)
2. Correction Factor(dB/m) = Antenna Factor(dB/m) + Cable Factor(dB) – Pre-Amplifier Factor(dB)
3. Margin value = Emission Level – Limit value
4. The other emission levels were very low against the limit.

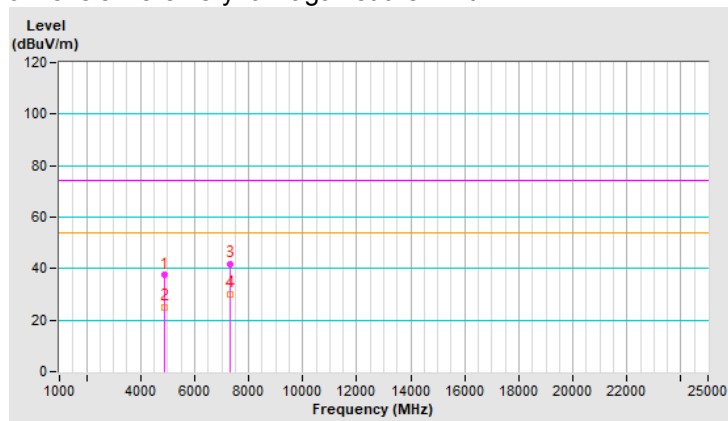

<b>CHANNEL</b>	TX Channel 11	<b>DETECTOR FUNCTION</b>	Peak (PK)
<b>FREQUENCY RANGE</b>	1GHz ~ 25GHz		Average (AV)

ANTENNA POLARITY & TEST DISTANCE: HORIZONTAL AT 3 M								
NO.	FREQ. (MHz)	EMISSION LEVEL (dBuV/m)	LIMIT (dBuV/m)	MARGIN (dB)	ANTENNA HEIGHT (m)	TABLE ANGLE (Degree)	RAW VALUE (dBuV)	CORRECTION FACTOR (dB/m)
1	4924.00	37.3 PK	74.0	-36.7	1.10 H	282	34.6	2.7
2	4924.00	24.9 AV	54.0	-29.1	1.10 H	282	22.2	2.7
3	7386.00	42.7 PK	74.0	-31.3	1.38 H	27	33.7	9.0
4	7386.00	30.8 AV	54.0	-23.2	1.38 H	27	21.8	9.0

**REMARKS:**

1. Emission Level(dBuV/m) = Raw Value(dBuV) + Correction Factor(dB/m)
2. Correction Factor(dB/m) = Antenna Factor(dB/m) + Cable Factor(dB) – Pre-Amplifier Factor(dB)
3. Margin value = Emission Level – Limit value
4. The other emission levels were very low against the limit.

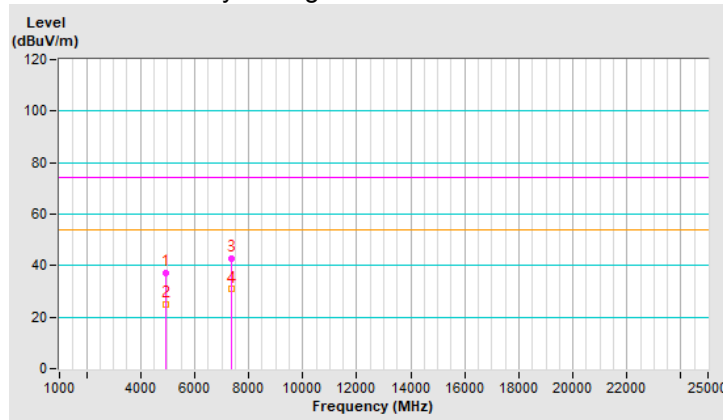

<b>CHANNEL</b>	TX Channel 11	<b>DETECTOR FUNCTION</b>	Peak (PK)
<b>FREQUENCY RANGE</b>	1GHz ~ 25GHz		Average (AV)

ANTENNA POLARITY & TEST DISTANCE: VERTICAL AT 3 M								
NO.	FREQ. (MHz)	EMISSION LEVEL (dBuV/m)	LIMIT (dBuV/m)	MARGIN (dB)	ANTENNA HEIGHT (m)	TABLE ANGLE (Degree)	RAW VALUE (dBuV)	CORRECTION FACTOR (dB/m)
1	4924.00	37.9 PK	74.0	-36.1	1.58 V	104	35.2	2.7
2	4924.00	25.6 AV	54.0	-28.4	1.58 V	104	22.9	2.7
3	7386.00	42.4 PK	74.0	-31.6	1.38 V	110	33.4	9.0
4	7386.00	30.4 AV	54.0	-23.6	1.38 V	110	21.4	9.0

**REMARKS:**

1. Emission Level(dBuV/m) = Raw Value(dBuV) + Correction Factor(dB/m)
2. Correction Factor(dB/m) = Antenna Factor(dB/m) + Cable Factor(dB) – Pre-Amplifier Factor(dB)
3. Margin value = Emission Level – Limit value
4. The other emission levels were very low against the limit.

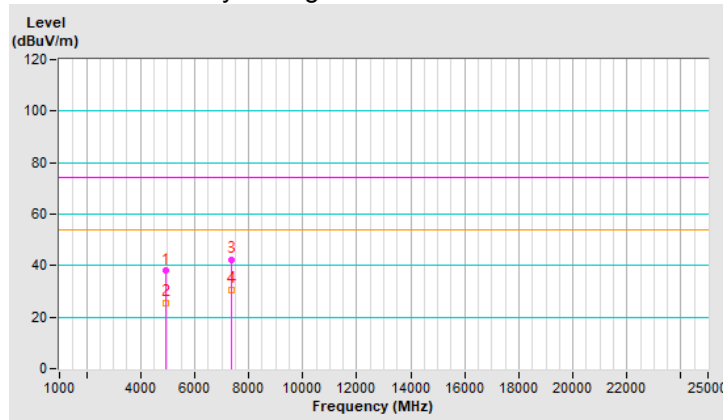

802.11g

<b>CHANNEL</b>	TX Channel 1	<b>DETECTOR FUNCTION</b>	Peak (PK)
<b>FREQUENCY RANGE</b>	1GHz ~ 25GHz		Average (AV)

ANTENNA POLARITY & TEST DISTANCE: HORIZONTAL AT 3 M								
NO.	FREQ. (MHz)	EMISSION LEVEL (dBuV/m)	LIMIT (dBuV/m)	MARGIN (dB)	ANTENNA HEIGHT (m)	TABLE ANGLE (Degree)	RAW VALUE (dBuV)	CORRECTION FACTOR (dB/m)
1	4824.00	37.6 PK	74.0	-36.4	1.06 H	284	34.7	2.9
2	4824.00	25.1 AV	54.0	-28.9	1.06 H	284	22.2	2.9

**REMARKS:**

1. Emission Level(dBuV/m) = Raw Value(dBuV) + Correction Factor(dB/m)
2. Correction Factor(dB/m) = Antenna Factor(dB/m) + Cable Factor(dB) – Pre-Amplifier Factor(dB)
3. Margin value = Emission Level – Limit value
4. The other emission levels were very low against the limit.

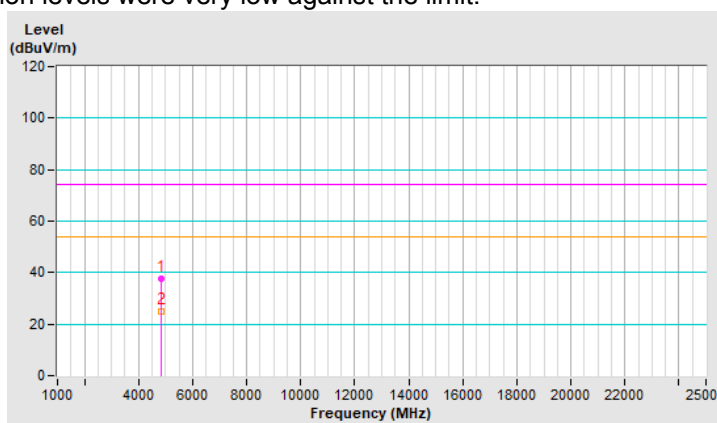

<b>CHANNEL</b>	TX Channel 1	<b>DETECTOR FUNCTION</b>	Peak (PK)
<b>FREQUENCY RANGE</b>	1GHz ~ 25GHz		Average (AV)

ANTENNA POLARITY & TEST DISTANCE: VERTICAL AT 3 M								
NO.	FREQ. (MHz)	EMISSION LEVEL (dBuV/m)	LIMIT (dBuV/m)	MARGIN (dB)	ANTENNA HEIGHT (m)	TABLE ANGLE (Degree)	RAW VALUE (dBuV)	CORRECTION FACTOR (dB/m)
1	4824.00	37.8 PK	74.0	-36.2	1.61 V	90	34.9	2.9
2	4824.00	25.7 AV	54.0	-28.3	1.61 V	90	22.8	2.9

**REMARKS:**

1. Emission Level(dBuV/m) = Raw Value(dBuV) + Correction Factor(dB/m)
2. Correction Factor(dB/m) = Antenna Factor(dB/m) + Cable Factor(dB) – Pre-Amplifier Factor(dB)
3. Margin value = Emission Level – Limit value
4. The other emission levels were very low against the limit.

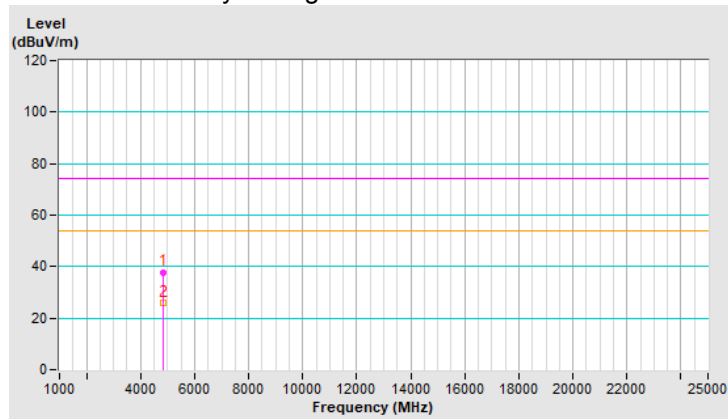

<b>CHANNEL</b>	TX Channel 6	<b>DETECTOR FUNCTION</b>	Peak (PK)
<b>FREQUENCY RANGE</b>	1GHz ~ 25GHz		Average (AV)

**ANTENNA POLARITY & TEST DISTANCE: HORIZONTAL AT 3 M**

NO.	FREQ. (MHz)	EMISSION LEVEL (dBuV/m)	LIMIT (dBuV/m)	MARGIN (dB)	ANTENNA HEIGHT (m)	TABLE ANGLE (Degree)	RAW VALUE (dBuV)	CORRECTION FACTOR (dB/m)
1	4874.00	37.7 PK	74.0	-36.3	1.12 H	295	34.9	2.8
2	4874.00	25.1 AV	54.0	-28.9	1.12 H	295	22.3	2.8
3	7311.00	42.7 PK	74.0	-31.3	1.43 H	30	33.8	8.9
4	7311.00	30.8 AV	54.0	-23.2	1.43 H	30	21.9	8.9

**REMARKS:**

1. Emission Level(dBuV/m) = Raw Value(dBuV) + Correction Factor(dB/m)
2. Correction Factor(dB/m) = Antenna Factor(dB/m) + Cable Factor(dB) – Pre-Amplifier Factor(dB)
3. Margin value = Emission Level – Limit value
4. The other emission levels were very low against the limit.

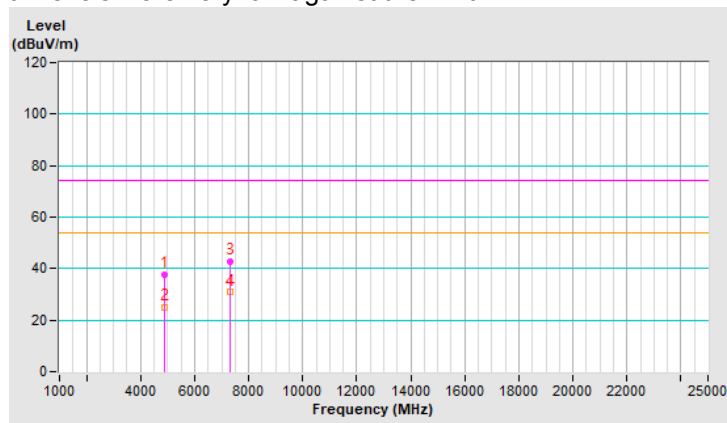

<b>CHANNEL</b>	TX Channel 6	<b>DETECTOR FUNCTION</b>	Peak (PK)
<b>FREQUENCY RANGE</b>	1GHz ~ 25GHz		Average (AV)

ANTENNA POLARITY & TEST DISTANCE: VERTICAL AT 3 M								
NO.	FREQ. (MHz)	EMISSION LEVEL (dBuV/m)	LIMIT (dBuV/m)	MARGIN (dB)	ANTENNA HEIGHT (m)	TABLE ANGLE (Degree)	RAW VALUE (dBuV)	CORRECTION FACTOR (dB/m)
1	4874.00	37.6 PK	74.0	-36.4	1.56 V	101	34.8	2.8
2	4874.00	25.3 AV	54.0	-28.7	1.56 V	101	22.5	2.8
3	7311.00	41.8 PK	74.0	-32.2	1.37 V	99	32.9	8.9
4	7311.00	30.0 AV	54.0	-24.0	1.37 V	99	21.1	8.9

**REMARKS:**

1. Emission Level(dBuV/m) = Raw Value(dBuV) + Correction Factor(dB/m)
2. Correction Factor(dB/m) = Antenna Factor(dB/m) + Cable Factor(dB) – Pre-Amplifier Factor(dB)
3. Margin value = Emission Level – Limit value
4. The other emission levels were very low against the limit.

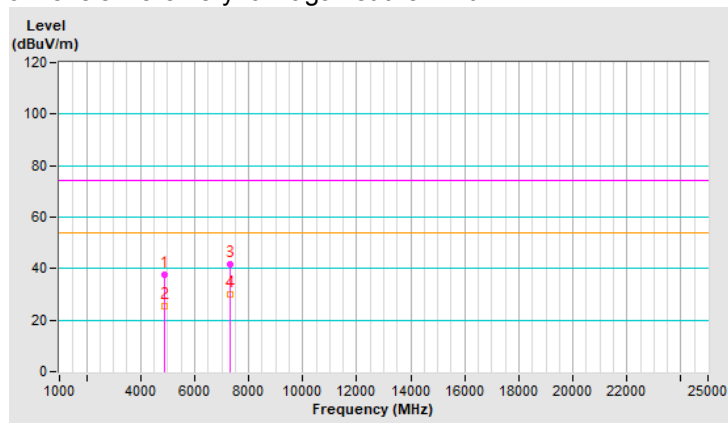

<b>CHANNEL</b>	TX Channel 11	<b>DETECTOR FUNCTION</b>	Peak (PK)
<b>FREQUENCY RANGE</b>	1GHz ~ 25GHz		Average (AV)

**ANTENNA POLARITY & TEST DISTANCE: HORIZONTAL AT 3 M**

NO.	FREQ. (MHz)	EMISSION LEVEL (dBuV/m)	LIMIT (dBuV/m)	MARGIN (dB)	ANTENNA HEIGHT (m)	TABLE ANGLE (Degree)	RAW VALUE (dBuV)	CORRECTION FACTOR (dB/m)
1	4924.00	38.0 PK	74.0	-36.0	1.07 H	296	35.3	2.7
2	4924.00	25.3 AV	54.0	-28.7	1.07 H	296	22.6	2.7
3	7386.00	42.8 PK	74.0	-31.2	1.43 H	36	33.8	9.0
4	7386.00	31.2 AV	54.0	-22.8	1.43 H	36	22.2	9.0

**REMARKS:**

1. Emission Level(dBuV/m) = Raw Value(dBuV) + Correction Factor(dB/m)
2. Correction Factor(dB/m) = Antenna Factor(dB/m) + Cable Factor(dB) – Pre-Amplifier Factor(dB)
3. Margin value = Emission Level – Limit value
4. The other emission levels were very low against the limit.

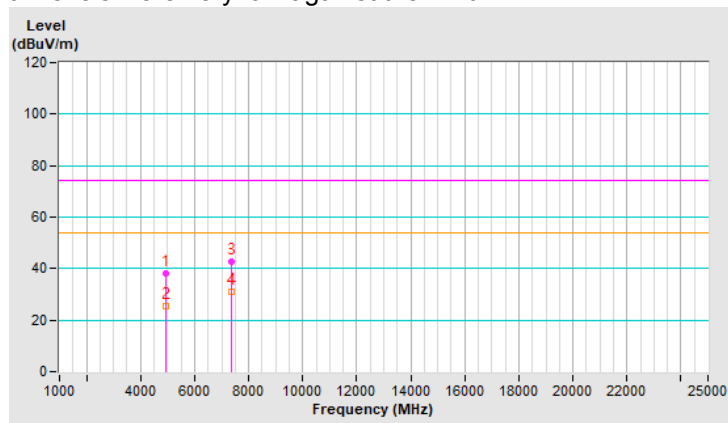



<b>CHANNEL</b>	TX Channel 11	<b>DETECTOR FUNCTION</b>	Peak (PK)
<b>FREQUENCY RANGE</b>	1GHz ~ 25GHz		Average (AV)

ANTENNA POLARITY & TEST DISTANCE: VERTICAL AT 3 M								
NO.	FREQ. (MHz)	EMISSION LEVEL (dBuV/m)	LIMIT (dBuV/m)	MARGIN (dB)	ANTENNA HEIGHT (m)	TABLE ANGLE (Degree)	RAW VALUE (dBuV)	CORRECTION FACTOR (dB/m)
1	4924.00	37.5 PK	74.0	-36.5	1.54 V	93	34.8	2.7
2	4924.00	25.3 AV	54.0	-28.7	1.54 V	93	22.6	2.7
3	7386.00	42.1 PK	74.0	-31.9	1.36 V	116	33.1	9.0
4	7386.00	30.3 AV	54.0	-23.7	1.36 V	116	21.3	9.0

**REMARKS:**

1. Emission Level(dBuV/m) = Raw Value(dBuV) + Correction Factor(dB/m)
2. Correction Factor(dB/m) = Antenna Factor(dB/m) + Cable Factor(dB) – Pre-Amplifier Factor(dB)
3. Margin value = Emission Level – Limit value
4. The other emission levels were very low against the limit.

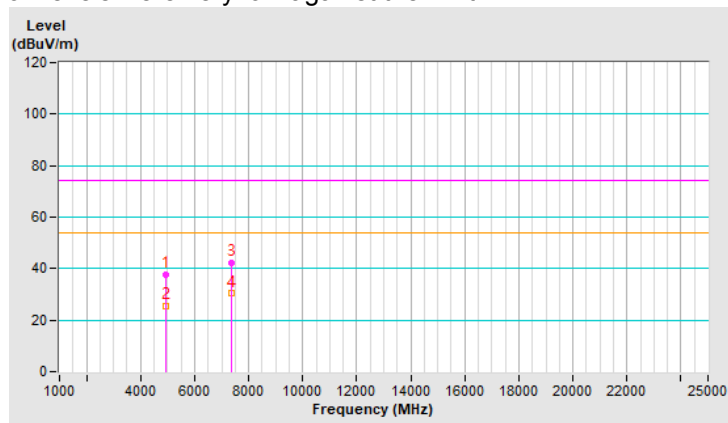

802.11n (HT20)

<b>CHANNEL</b>	TX Channel 1	<b>DETECTOR FUNCTION</b>	Peak (PK)
<b>FREQUENCY RANGE</b>	1GHz ~ 25GHz		Average (AV)

ANTENNA POLARITY & TEST DISTANCE: HORIZONTAL AT 3 M								
NO.	FREQ. (MHz)	EMISSION LEVEL (dBuV/m)	LIMIT (dBuV/m)	MARGIN (dB)	ANTENNA HEIGHT (m)	TABLE ANGLE (Degree)	RAW VALUE (dBuV)	CORRECTION FACTOR (dB/m)
1	4824.00	37.9 PK	74.0	-36.1	1.12 H	292	35.0	2.9
2	4824.00	25.2 AV	54.0	-28.8	1.12 H	292	22.3	2.9

**REMARKS:**

1. Emission Level(dBuV/m) = Raw Value(dBuV) + Correction Factor(dB/m)
2. Correction Factor(dB/m) = Antenna Factor(dB/m) + Cable Factor(dB) – Pre-Amplifier Factor(dB)
3. Margin value = Emission Level – Limit value
4. The other emission levels were very low against the limit.

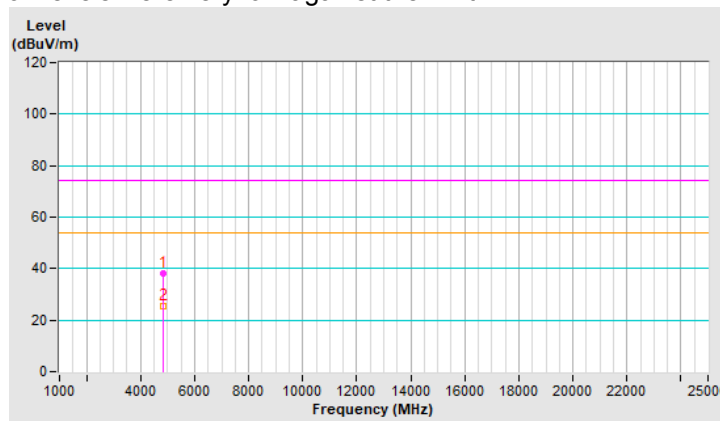

<b>CHANNEL</b>	TX Channel 1	<b>DETECTOR FUNCTION</b>	Peak (PK)
<b>FREQUENCY RANGE</b>	1GHz ~ 25GHz		Average (AV)

**ANTENNA POLARITY & TEST DISTANCE: VERTICAL AT 3 M**

NO.	FREQ. (MHz)	EMISSION LEVEL (dBuV/m)	LIMIT (dBuV/m)	MARGIN (dB)	ANTENNA HEIGHT (m)	TABLE ANGLE (Degree)	RAW VALUE (dBuV)	CORRECTION FACTOR (dB/m)
1	4824.00	38.1 PK	74.0	-35.9	1.59 V	105	35.2	2.9
2	4824.00	25.9 AV	54.0	-28.1	1.59 V	105	23.0	2.9

**REMARKS:**

1. Emission Level(dBuV/m) = Raw Value(dBuV) + Correction Factor(dB/m)
2. Correction Factor(dB/m) = Antenna Factor(dB/m) + Cable Factor(dB) – Pre-Amplifier Factor(dB)
3. Margin value = Emission Level – Limit value
4. The other emission levels were very low against the limit.

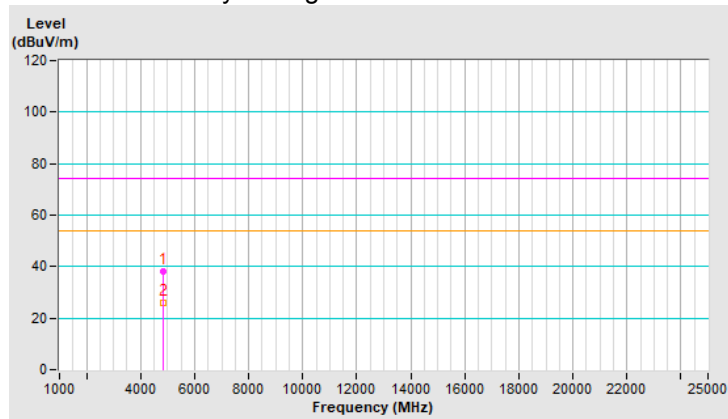

<b>CHANNEL</b>	TX Channel 6	<b>DETECTOR FUNCTION</b>	Peak (PK)
<b>FREQUENCY RANGE</b>	1GHz ~ 25GHz		Average (AV)

**ANTENNA POLARITY & TEST DISTANCE: HORIZONTAL AT 3 M**

NO.	FREQ. (MHz)	EMISSION LEVEL (dBuV/m)	LIMIT (dBuV/m)	MARGIN (dB)	ANTENNA HEIGHT (m)	TABLE ANGLE (Degree)	RAW VALUE (dBuV)	CORRECTION FACTOR (dB/m)
1	4874.00	37.9 PK	74.0	-36.1	1.09 H	293	35.1	2.8
2	4874.00	25.2 AV	54.0	-28.8	1.09 H	293	22.4	2.8
3	7311.00	43.0 PK	74.0	-31.0	1.36 H	20	34.1	8.9
4	7311.00	30.9 AV	54.0	-23.1	1.36 H	20	22.0	8.9

**REMARKS:**

1. Emission Level(dBuV/m) = Raw Value(dBuV) + Correction Factor(dB/m)
2. Correction Factor(dB/m) = Antenna Factor(dB/m) + Cable Factor(dB) – Pre-Amplifier Factor(dB)
3. Margin value = Emission Level – Limit value
4. The other emission levels were very low against the limit.

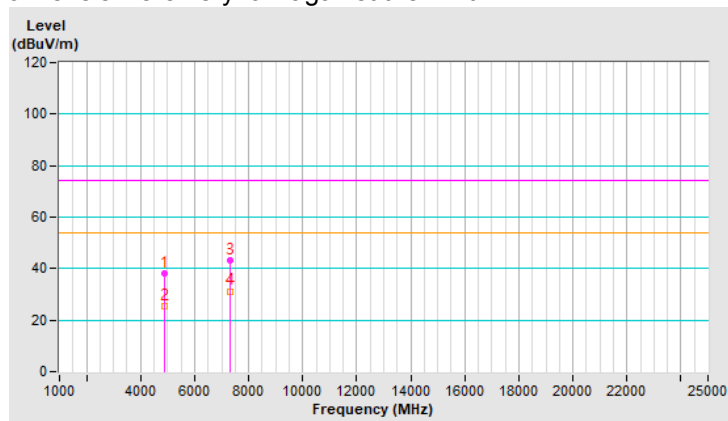

<b>CHANNEL</b>	TX Channel 6	<b>DETECTOR FUNCTION</b>	Peak (PK)
<b>FREQUENCY RANGE</b>	1GHz ~ 25GHz		Average (AV)

ANTENNA POLARITY & TEST DISTANCE: VERTICAL AT 3 M								
NO.	FREQ. (MHz)	EMISSION LEVEL (dBuV/m)	LIMIT (dBuV/m)	MARGIN (dB)	ANTENNA HEIGHT (m)	TABLE ANGLE (Degree)	RAW VALUE (dBuV)	CORRECTION FACTOR (dB/m)
1	4874.00	38.3 PK	74.0	-35.7	1.56 V	119	35.5	2.8
2	4874.00	26.0 AV	54.0	-28.0	1.56 V	119	23.2	2.8
3	7311.00	42.8 PK	74.0	-31.2	1.41 V	98	33.9	8.9
4	7311.00	30.9 AV	54.0	-23.1	1.41 V	98	22.0	8.9

**REMARKS:**

1. Emission Level(dBuV/m) = Raw Value(dBuV) + Correction Factor(dB/m)
2. Correction Factor(dB/m) = Antenna Factor(dB/m) + Cable Factor(dB) – Pre-Amplifier Factor(dB)
3. Margin value = Emission Level – Limit value
4. The other emission levels were very low against the limit.

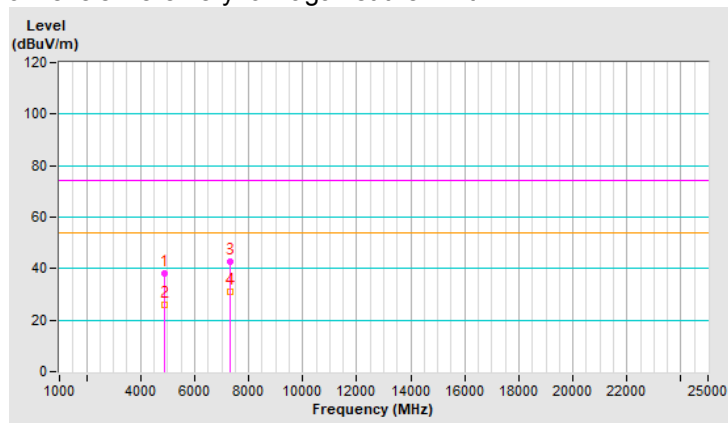

<b>CHANNEL</b>	TX Channel 11	<b>DETECTOR FUNCTION</b>	Peak (PK)
<b>FREQUENCY RANGE</b>	1GHz ~ 25GHz		Average (AV)

**ANTENNA POLARITY & TEST DISTANCE: HORIZONTAL AT 3 M**

NO.	FREQ. (MHz)	EMISSION LEVEL (dBuV/m)	LIMIT (dBuV/m)	MARGIN (dB)	ANTENNA HEIGHT (m)	TABLE ANGLE (Degree)	RAW VALUE (dBuV)	CORRECTION FACTOR (dB/m)
1	4924.00	36.9 PK	74.0	-37.1	1.09 H	268	34.2	2.7
2	4924.00	24.5 AV	54.0	-29.5	1.09 H	268	21.8	2.7
3	7386.00	43.2 PK	74.0	-30.8	1.36 H	25	34.2	9.0
4	7386.00	31.3 AV	54.0	-22.7	1.36 H	25	22.3	9.0

**REMARKS:**

1. Emission Level(dBuV/m) = Raw Value(dBuV) + Correction Factor(dB/m)
2. Correction Factor(dB/m) = Antenna Factor(dB/m) + Cable Factor(dB) – Pre-Amplifier Factor(dB)
3. Margin value = Emission Level – Limit value
4. The other emission levels were very low against the limit.

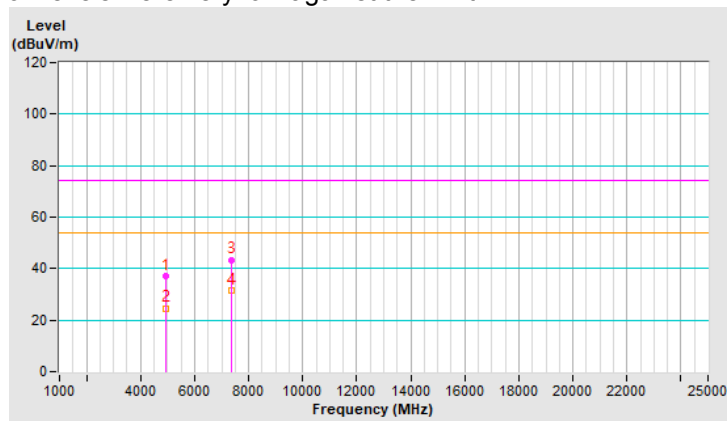

<b>CHANNEL</b>	TX Channel 11	<b>DETECTOR FUNCTION</b>	Peak (PK)
<b>FREQUENCY RANGE</b>	1GHz ~ 25GHz		Average (AV)

ANTENNA POLARITY & TEST DISTANCE: VERTICAL AT 3 M								
NO.	FREQ. (MHz)	EMISSION LEVEL (dBuV/m)	LIMIT (dBuV/m)	MARGIN (dB)	ANTENNA HEIGHT (m)	TABLE ANGLE (Degree)	RAW VALUE (dBuV)	CORRECTION FACTOR (dB/m)
1	4924.00	37.6 PK	74.0	-36.4	1.57 V	97	34.9	2.7
2	4924.00	25.5 AV	54.0	-28.5	1.57 V	97	22.8	2.7
3	7386.00	43.1 PK	74.0	-30.9	1.39 V	110	34.1	9.0
4	7386.00	30.9 AV	54.0	-23.1	1.39 V	110	21.9	9.0

**REMARKS:**

1. Emission Level(dBuV/m) = Raw Value(dBuV) + Correction Factor(dB/m)
2. Correction Factor(dB/m) = Antenna Factor(dB/m) + Cable Factor(dB) – Pre-Amplifier Factor(dB)
3. Margin value = Emission Level – Limit value
4. The other emission levels were very low against the limit.

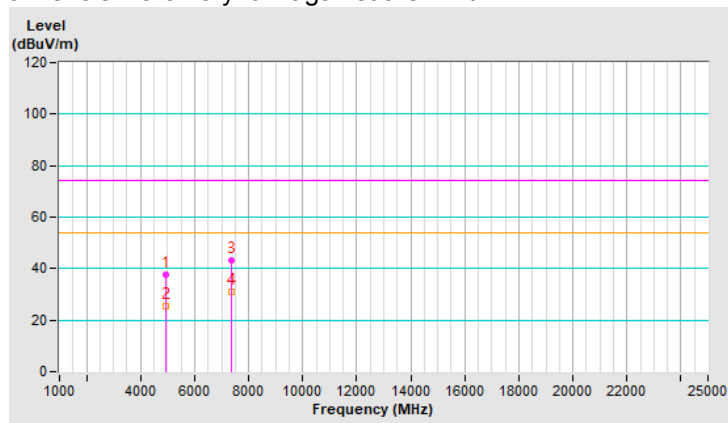

### 802.11n (HT40)

<b>CHANNEL</b>	TX Channel 3	<b>DETECTOR FUNCTION</b>	Peak (PK)
<b>FREQUENCY RANGE</b>	1GHz ~ 25GHz		Average (AV)

ANTENNA POLARITY & TEST DISTANCE: HORIZONTAL AT 3 M								
NO.	FREQ. (MHz)	EMISSION LEVEL (dBuV/m)	LIMIT (dBuV/m)	MARGIN (dB)	ANTENNA HEIGHT (m)	TABLE ANGLE (Degree)	RAW VALUE (dBuV)	CORRECTION FACTOR (dB/m)
1	4844.00	37.9 PK	74.0	-36.1	1.09 H	276	35.0	2.9
2	4844.00	25.4 AV	54.0	-28.6	1.09 H	276	22.5	2.9
3	7266.00	42.4 PK	74.0	-31.6	1.34 H	28	33.6	8.8
4	7266.00	30.5 AV	54.0	-23.5	1.34 H	28	21.7	8.8

#### REMARKS:

1. Emission Level(dBuV/m) = Raw Value(dBuV) + Correction Factor(dB/m)
2. Correction Factor(dB/m) = Antenna Factor(dB/m) + Cable Factor(dB) – Pre-Amplifier Factor(dB)
3. Margin value = Emission Level – Limit value
4. The other emission levels were very low against the limit.

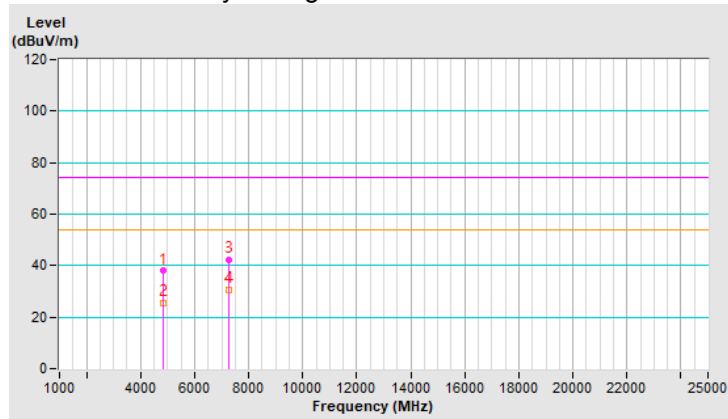



<b>CHANNEL</b>	TX Channel 3	<b>DETECTOR FUNCTION</b>	Peak (PK)
<b>FREQUENCY RANGE</b>	1GHz ~ 25GHz		Average (AV)

ANTENNA POLARITY & TEST DISTANCE: VERTICAL AT 3 M								
NO.	FREQ. (MHz)	EMISSION LEVEL (dBuV/m)	LIMIT (dBuV/m)	MARGIN (dB)	ANTENNA HEIGHT (m)	TABLE ANGLE (Degree)	RAW VALUE (dBuV)	CORRECTION FACTOR (dB/m)
1	4844.00	37.7 PK	74.0	-36.3	1.56 V	112	34.8	2.9
2	4844.00	25.6 AV	54.0	-28.4	1.56 V	112	22.7	2.9
3	7266.00	42.5 PK	74.0	-31.5	1.41 V	108	33.7	8.8
4	7266.00	30.5 AV	54.0	-23.5	1.41 V	108	21.7	8.8

**REMARKS:**

1. Emission Level(dBuV/m) = Raw Value(dBuV) + Correction Factor(dB/m)
2. Correction Factor(dB/m) = Antenna Factor(dB/m) + Cable Factor(dB) – Pre-Amplifier Factor(dB)
3. Margin value = Emission Level – Limit value
4. The other emission levels were very low against the limit.

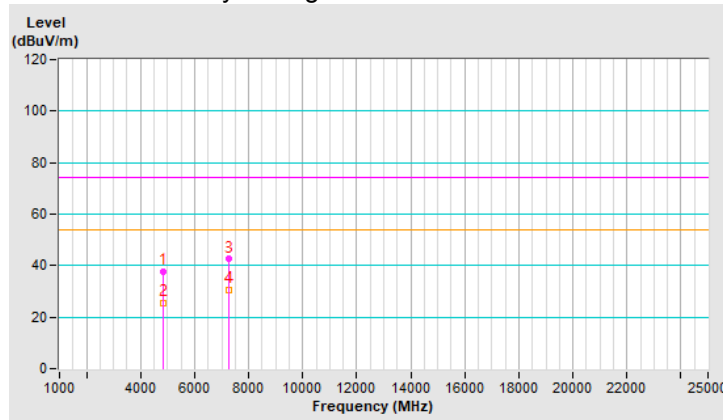

<b>CHANNEL</b>	TX Channel 6	<b>DETECTOR FUNCTION</b>	Peak (PK)
<b>FREQUENCY RANGE</b>	1GHz ~ 25GHz		Average (AV)

**ANTENNA POLARITY & TEST DISTANCE: HORIZONTAL AT 3 M**

NO.	FREQ. (MHz)	EMISSION LEVEL (dBuV/m)	LIMIT (dBuV/m)	MARGIN (dB)	ANTENNA HEIGHT (m)	TABLE ANGLE (Degree)	RAW VALUE (dBuV)	CORRECTION FACTOR (dB/m)
1	4874.00	36.6 PK	74.0	-37.4	1.15 H	283	33.8	2.8
2	4874.00	24.4 AV	54.0	-29.6	1.15 H	283	21.6	2.8
3	7311.00	42.2 PK	74.0	-31.8	1.40 H	21	33.3	8.9
4	7311.00	30.5 AV	54.0	-23.5	1.40 H	21	21.6	8.9

**REMARKS:**

1. Emission Level(dBuV/m) = Raw Value(dBuV) + Correction Factor(dB/m)
2. Correction Factor(dB/m) = Antenna Factor(dB/m) + Cable Factor(dB) – Pre-Amplifier Factor(dB)
3. Margin value = Emission Level – Limit value
4. The other emission levels were very low against the limit.

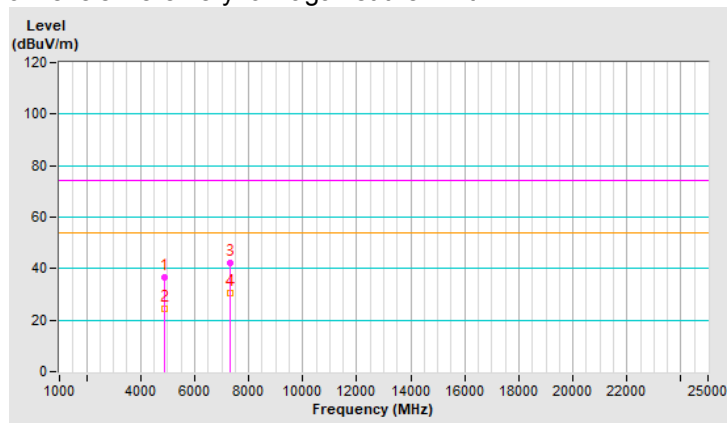

<b>CHANNEL</b>	TX Channel 6	<b>DETECTOR FUNCTION</b>	Peak (PK)
<b>FREQUENCY RANGE</b>	1GHz ~ 25GHz		Average (AV)

ANTENNA POLARITY & TEST DISTANCE: VERTICAL AT 3 M								
NO.	FREQ. (MHz)	EMISSION LEVEL (dBuV/m)	LIMIT (dBuV/m)	MARGIN (dB)	ANTENNA HEIGHT (m)	TABLE ANGLE (Degree)	RAW VALUE (dBuV)	CORRECTION FACTOR (dB/m)
1	4874.00	37.8 PK	74.0	-36.2	1.54 V	117	35.0	2.8
2	4874.00	25.5 AV	54.0	-28.5	1.54 V	117	22.7	2.8
3	7311.00	42.2 PK	74.0	-31.8	1.38 V	107	33.3	8.9
4	7311.00	30.3 AV	54.0	-23.7	1.38 V	107	21.4	8.9

**REMARKS:**

1. Emission Level(dBuV/m) = Raw Value(dBuV) + Correction Factor(dB/m)
2. Correction Factor(dB/m) = Antenna Factor(dB/m) + Cable Factor(dB) – Pre-Amplifier Factor(dB)
3. Margin value = Emission Level – Limit value
4. The other emission levels were very low against the limit.

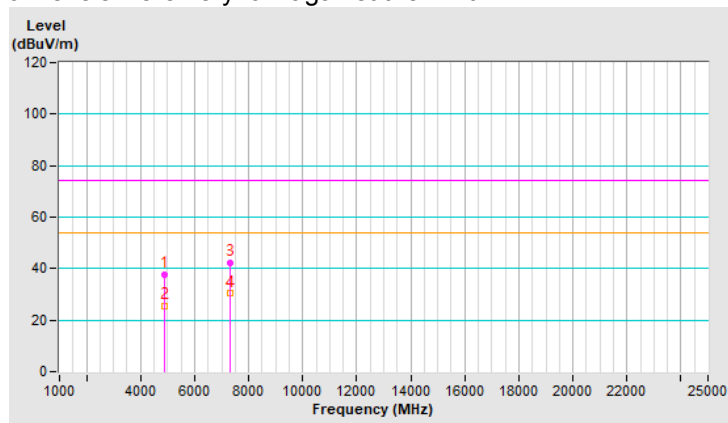

<b>CHANNEL</b>	TX Channel 9	<b>DETECTOR FUNCTION</b>	Peak (PK)
<b>FREQUENCY RANGE</b>	1GHz ~ 25GHz		Average (AV)

**ANTENNA POLARITY & TEST DISTANCE: HORIZONTAL AT 3 M**

NO.	FREQ. (MHz)	EMISSION LEVEL (dBuV/m)	LIMIT (dBuV/m)	MARGIN (dB)	ANTENNA HEIGHT (m)	TABLE ANGLE (Degree)	RAW VALUE (dBuV)	CORRECTION FACTOR (dB/m)
1	4904.00	37.7 PK	74.0	-36.3	1.12 H	293	35.0	2.7
2	4904.00	25.1 AV	54.0	-28.9	1.12 H	293	22.4	2.7
3	7356.00	42.4 PK	74.0	-31.6	1.37 H	27	33.5	8.9
4	7356.00	30.3 AV	54.0	-23.7	1.37 H	27	21.4	8.9

**REMARKS:**

1. Emission Level(dBuV/m) = Raw Value(dBuV) + Correction Factor(dB/m)
2. Correction Factor(dB/m) = Antenna Factor(dB/m) + Cable Factor(dB) – Pre-Amplifier Factor(dB)
3. Margin value = Emission Level – Limit value
4. The other emission levels were very low against the limit.

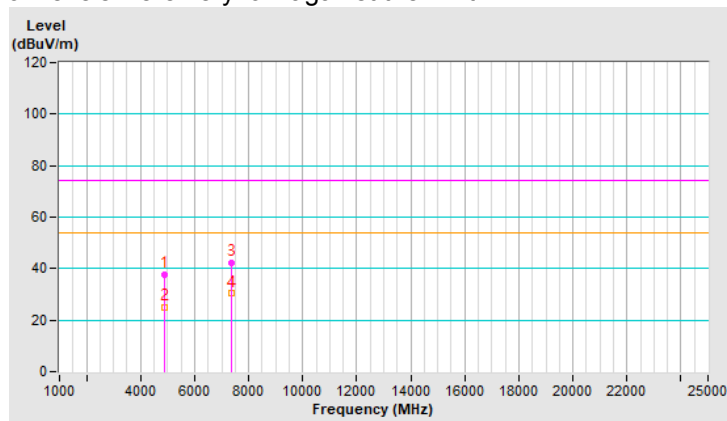

<b>CHANNEL</b>	TX Channel 9	<b>DETECTOR FUNCTION</b>	Peak (PK)
<b>FREQUENCY RANGE</b>	1GHz ~ 25GHz		Average (AV)

ANTENNA POLARITY & TEST DISTANCE: VERTICAL AT 3 M								
NO.	FREQ. (MHz)	EMISSION LEVEL (dBuV/m)	LIMIT (dBuV/m)	MARGIN (dB)	ANTENNA HEIGHT (m)	TABLE ANGLE (Degree)	RAW VALUE (dBuV)	CORRECTION FACTOR (dB/m)
1	4904.00	38.5 PK	74.0	-35.5	1.61 V	109	35.8	2.7
2	4904.00	26.0 AV	54.0	-28.0	1.61 V	109	23.3	2.7
3	7356.00	43.0 PK	74.0	-31.0	1.37 V	123	34.1	8.9
4	7356.00	30.8 AV	54.0	-23.2	1.37 V	123	21.9	8.9

**REMARKS:**

1. Emission Level(dBuV/m) = Raw Value(dBuV) + Correction Factor(dB/m)
2. Correction Factor(dB/m) = Antenna Factor(dB/m) + Cable Factor(dB) – Pre-Amplifier Factor(dB)
3. Margin value = Emission Level – Limit value
4. The other emission levels were very low against the limit.

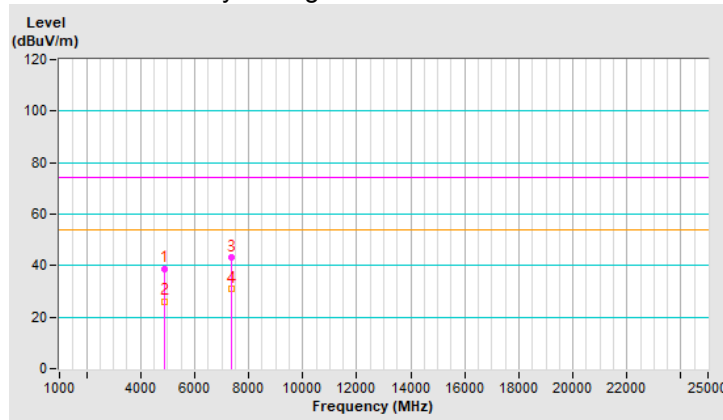

Below 1GHz Data:

802.11b

<b>CHANNEL</b>	TX Channel 6	<b>DETECTOR FUNCTION</b>	Quasi-Peak (QP)
<b>FREQUENCY RANGE</b>	9kHz ~ 1GHz		

**ANTENNA POLARITY & TEST DISTANCE: HORIZONTAL AT 3 M**

NO.	FREQ. (MHz)	EMISSION LEVEL (dBuV/m)	LIMIT (dBuV/m)	MARGIN (dB)	ANTENNA HEIGHT (m)	TABLE ANGLE (Degree)	RAW VALUE (dBuV)	CORRECTION FACTOR (dB/m)
1	91.81	33.0 QP	43.5	-10.5	2.00 H	299	46.2	-13.2
2	137.52	34.0 QP	43.5	-9.5	2.00 H	64	41.7	-7.7
3	165.99	36.6 QP	43.5	-6.9	1.50 H	278	44.0	-7.4
4	242.58	36.7 QP	46.0	-9.3	1.00 H	295	45.3	-8.6
5	299.30	37.2 QP	46.0	-8.8	1.00 H	276	43.6	-6.4
6	716.74	38.7 QP	46.0	-7.3	1.00 H	23	36.0	2.7

**REMARKS:**

1. Emission Level(dBuV/m) = Raw Value(dBuV) + Correction Factor(dB/m)
2. Correction Factor(dB/m) = Antenna Factor(dB/m) + Cable Factor(dB) – Pre-Amplifier Factor(dB)
3. Margin value = Emission Level – Limit value
4. The other emission levels were very low against the limit of frequency range 30MHz~1000MHz.
5. The emission levels were very low against the limit of frequency range 9kHz~30MHz: the amplitude of spurious emissions attenuated more than 20 dB below the permissible value to be report.

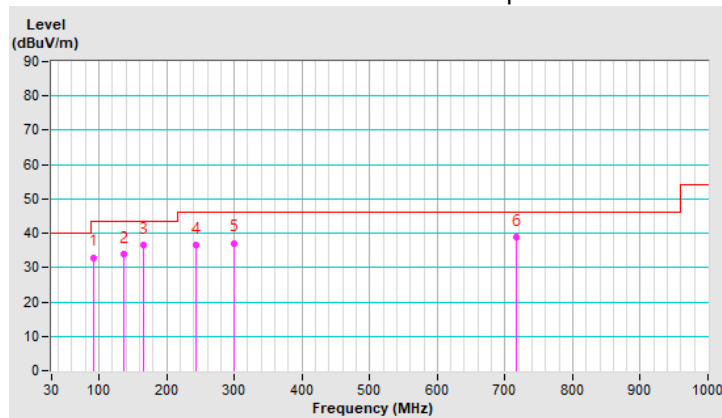

<b>CHANNEL</b>	TX Channel 6	<b>DETECTOR FUNCTION</b>	Quasi-Peak (QP)
<b>FREQUENCY RANGE</b>	9kHz ~ 1GHz		

ANTENNA POLARITY & TEST DISTANCE: VERTICAL AT 3 M								
NO.	FREQ. (MHz)	EMISSION LEVEL (dBuV/m)	LIMIT (dBuV/m)	MARGIN (dB)	ANTENNA HEIGHT (m)	TABLE ANGLE (Degree)	RAW VALUE (dBuV)	CORRECTION FACTOR (dB/m)
1	99.62	36.4 QP	43.5	-7.1	1.00 V	0	48.3	-11.9
2	165.99	32.7 QP	43.5	-10.8	1.00 V	22	40.1	-7.4
3	232.66	33.9 QP	46.0	-12.1	1.00 V	360	43.0	-9.1
4	299.34	36.1 QP	46.0	-9.9	2.00 V	166	42.5	-6.4
5	483.45	33.0 QP	46.0	-13.0	1.00 V	0	34.8	-1.8
6	716.71	37.2 QP	46.0	-8.8	2.00 V	345	34.5	2.7

**REMARKS:**

1. Emission Level(dBuV/m) = Raw Value(dBuV) + Correction Factor(dB/m)
2. Correction Factor(dB/m) = Antenna Factor(dB/m) + Cable Factor(dB) – Pre-Amplifier Factor(dB)
3. Margin value = Emission Level – Limit value
4. The other emission levels were very low against the limit of frequency range 30MHz~1000MHz.
5. The emission levels were very low against the limit of frequency range 9kHz~30MHz: the amplitude of spurious emissions attenuated more than 20 dB below the permissible value to be report.

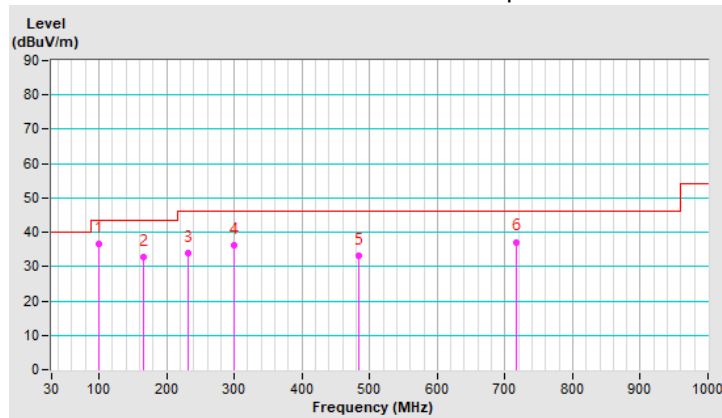

#### 4.1.8 Test Results (Conducted Measurement)

<b>Radiated versus Conducted Measurement</b>	
<input checked="" type="checkbox"/> Conducted measurement	<input type="checkbox"/> Radiated measurement
<p><u>For Radiated measurement:</u>            The level of unwanted emissions was measured when radiated by the cabinet or structure of the equipment with the antenna connector(s) terminated by a specified load (cabinet radiation)</p> <p><u>For Conducted measurement:</u>            The level of unwanted emissions was measured as their power in a specified load (conducted spurious emissions).</p> <p>Note: In order to obtain results more easily, change max hold to view. It has no effect on the result</p>	

<b>Conducted Measurement Factor</b>
<p>a. The composite gain will be used</p> <p style="margin-left: 20px;">i. For Mode 1: Composite gain = <math>10 \log[(10^{G0/10} + 10^{G1/10}) / 2] = 3.27 \text{ dBi}</math></p> <p style="margin-left: 20px;">ii. For Mode 2: Composite gain = 2.88 dBi</p> <p>b. For the out of band spurious the gain for the specific band may have been used rather than the highest gain across all bands.</p> <p>c. For the band edge the gain for the specific band may have been used.</p> <p>d. In restricted bands below 1000 MHz, add upper bound on ground plane reflection:            For <math>f = 30 - 1000 \text{ MHz}</math>, add 4.7 dB.</p> <p>Note: The conducted emission test was considered some factor to compute test result.</p>



## 4.1.8.1 Test Results (Mode 1)

## 802.11n (HT20) - Channel 1

## Conducted spurious emission table

## Chain 0

No.	Frequency (MHz)	Emission Level (dBuV/m)	Limit (dBuV/m)	Margin (dB)	Raw Value (dBm)	Correction Factor (dB)	EIRP Level (dBm)
1	2410.93 PK	111.27	*		10.12	5.89	16.01
2	2343.75 PK	55.96	74	-18.04	-45.19	5.89	-39.3
3	3181.25 PK	54.22	#		-46.93	5.89	-41.04
4	24642.06 PK	56.74	#		-44.41	5.89	-38.52
5	2412.5 AV	102.62	*		1.47	5.89	7.36
6	2350 AV	43.85	54	-10.15	-57.3	5.89	-51.41
7	3089.06 AV	42.16	#		-58.99	5.89	-53.1
8	21636.25 AV	44.13	#		-57.02	5.89	-51.13

Note :

- Emission Level (dBuV/m) = EIRP Level (dBm) – 20log(d) + 104.8  
d = measurement distance in 3 meters.
- Correction Factor(dB) = Antenna Gain (dBi) + 10 log ( 2 of TX antenna elements)
- \* : Fundamental frequency, the limit was restricted at the output power.
- # : Non-restricted frequency, the limit was restricted at the conducted out of band emission.

## Chain 1

No.	Frequency (MHz)	Emission Level (dBuV/m)	Limit (dBuV/m)	Margin (dB)	Raw Value (dBm)	Correction Factor (dB)	EIRP Level (dBm)
1	2410.93 PK	111.79	*		9.9	6.63	16.53
2	2345.31 PK	56.05	74	-17.95	-45.84	6.63	-39.21
3	3215.62 PK	55.23	#		-46.66	6.63	-40.03
4	24634.87 PK	57.2	#		-44.69	6.63	-38.06
5	2410.93 AV	102.61	*		0.72	6.63	7.35
6	2350 AV	45.07	54	-8.93	-56.82	6.63	-50.19
7	3215.62 AV	43.59	#		-58.3	6.63	-51.67
8	21653.5 AV	44.83	#		-57.06	6.63	-50.43

Note :

- Emission Level (dBuV/m) = EIRP Level (dBm) – 20log(d) + 104.8  
d = measurement distance in 3 meters.
- Correction Factor(dB) = Antenna Gain (dBi) + 10 log ( 2 of TX antenna elements)
- \* : Fundamental frequency, the limit was restricted at the output power.
- # : Non-restricted frequency, the limit was restricted at the conducted out of band emission.

### Chain 0

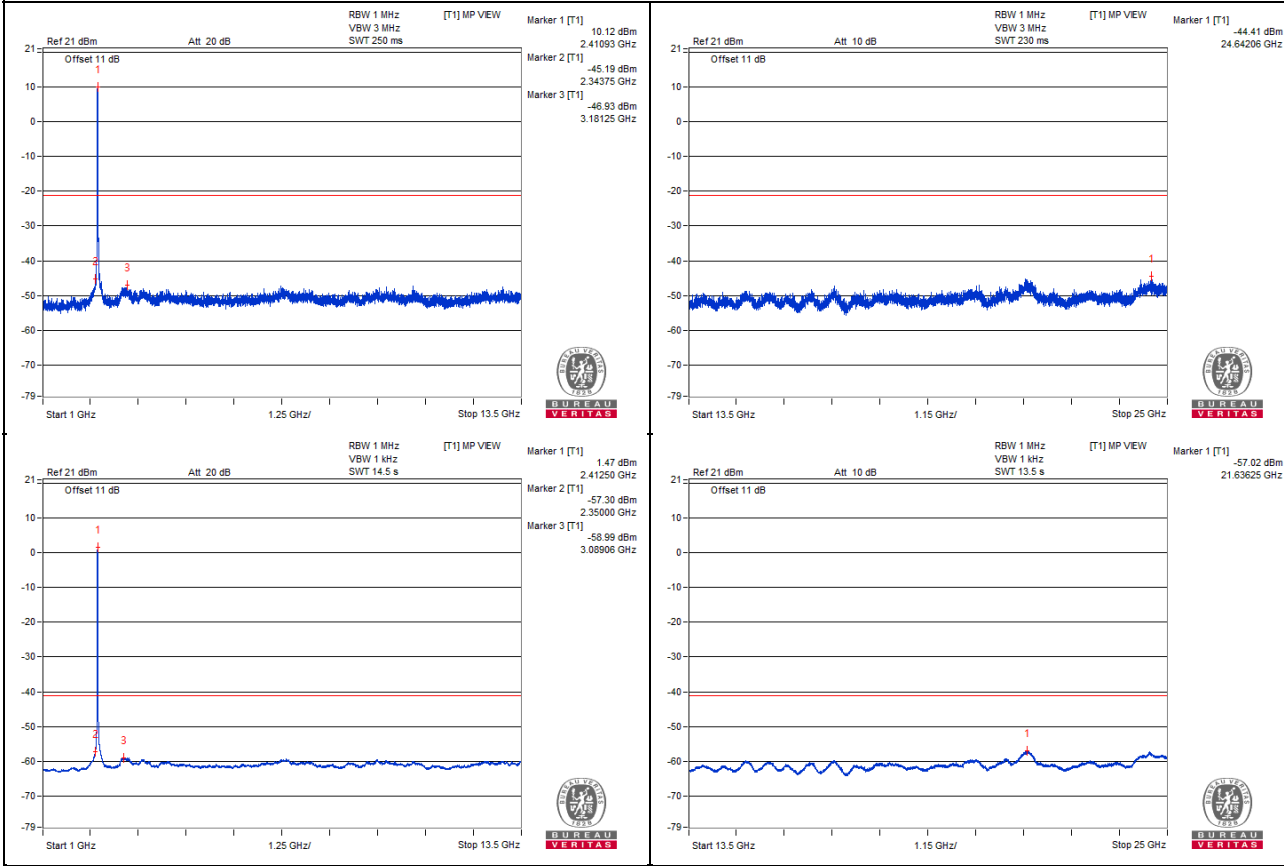

### Chain 1

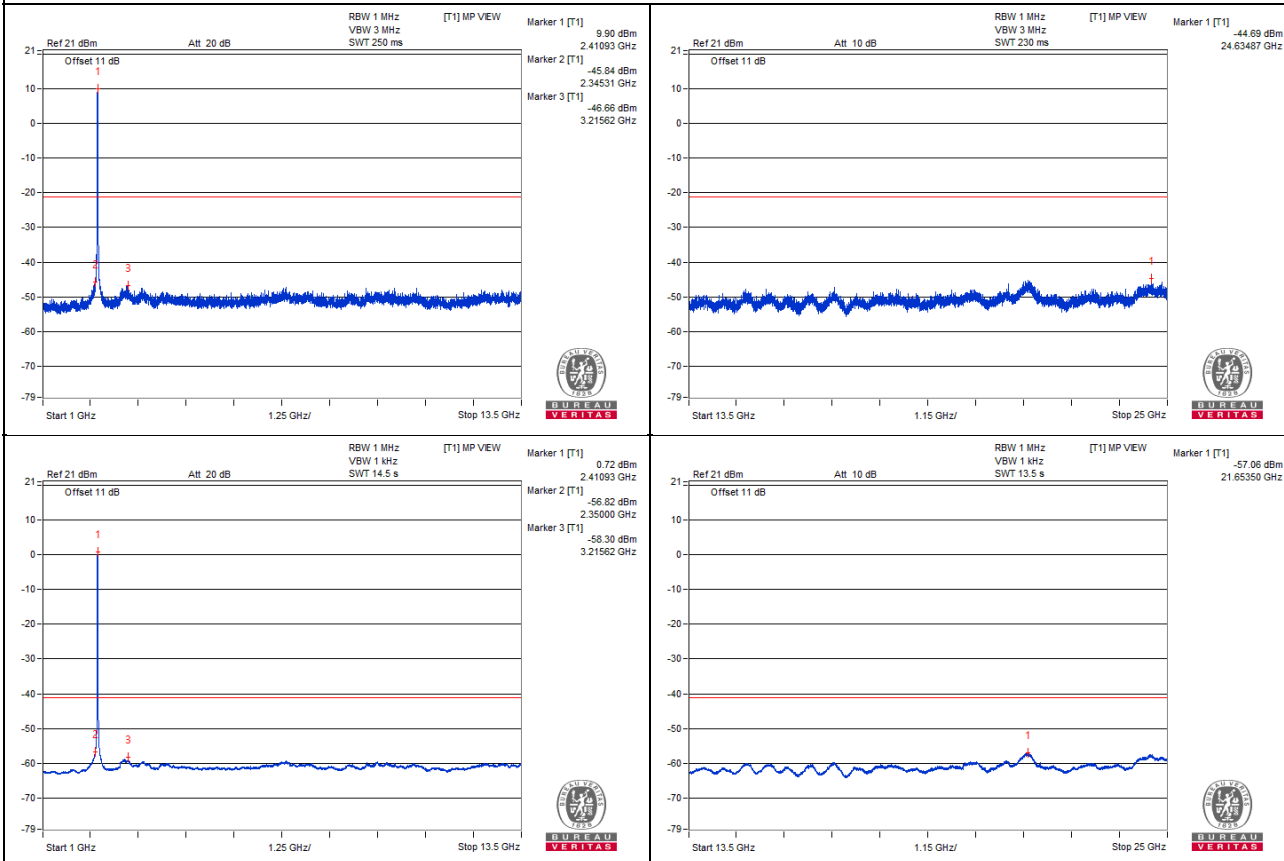

**Bandedge table**
**Chain 0**

No.	Frequency (MHz)	Emission Level (dBuV/m)	Limit (dBuV/m)	Margin (dB)	Raw Value (dBm)	Correction Factor (dB)	EIRP Level (dBm)
1	2411.41 PK	112.68	*		11.53	5.89	17.42
2	2390 PK	64.45	74	-9.55	-36.7	5.89	-30.81
3	2483.5 PK	53.43	74	-20.57	-47.72	5.89	-41.83
4	2389.56 PK	67.87	74	-6.13	-33.28	5.89	-27.39
5	2489.33 PK	57.42	74	-16.58	-43.73	5.89	-37.84
6	2410.98 AV	102.13	*		0.98	5.89	6.87
7	2390 AV	51.23	54	-2.77	-49.92	5.89	-44.03
8	2483.5 AV	43.47	54	-10.53	-57.68	5.89	-51.79
9	2390 AV	51.23	54	-2.77	-49.92	5.89	-44.03
10	2483.87 AV	43.5	54	-10.5	-57.65	5.89	-51.76

Note :

- Emission Level (dBuV/m) = EIRP Level (dBm) – 20log(d) + 104.8  
d = measurement distance in 3 meters.
- Correction Factor(dB) = Antenna Gain (dBi) + 10 log ( 2 of TX antenna elements)
- \* : Fundamental frequency, the limit was restricted at the output power.

**Chain 1**

No.	Frequency (MHz)	Emission Level (dBuV/m)	Limit (dBuV/m)	Margin (dB)	Raw Value (dBm)	Correction Factor (dB)	EIRP Level (dBm)
1	2410.53 PK	112.85	*		10.96	6.63	17.59
2	2390 PK	65.38	74	-8.62	-36.51	6.63	-29.88
3	2483.5 PK	54.91	74	-19.09	-46.98	6.63	-40.35
4	2389.87 PK	69	74	-5	-32.89	6.63	-26.26
5	2485.18 PK	56.55	74	-17.45	-45.34	6.63	-38.71
6	2410.98 AV	102.28	*		0.39	6.63	7.02
7	<b>2390 AV</b>	<b>52.49</b>	<b>54</b>	<b>-1.51</b>	<b>-49.4</b>	<b>6.63</b>	<b>-42.77</b>
8	2483.5 AV	43.38	54	-10.62	-58.51	6.63	-51.88
9	<b>2389.99 AV</b>	<b>52.49</b>	<b>54</b>	<b>-1.51</b>	<b>-49.4</b>	<b>6.63</b>	<b>-42.77</b>
10	2483.51 AV	43.38	54	-10.62	-58.51	6.63	-51.88

Note :

- Emission Level (dBuV/m) = EIRP Level (dBm) – 20log(d) + 104.8  
d = measurement distance in 3 meters.
- Correction Factor(dB) = Antenna Gain (dBi) + 10 log ( 2 of TX antenna elements)
- \* : Fundamental frequency, the limit was restricted at the output power.

### Chain 0

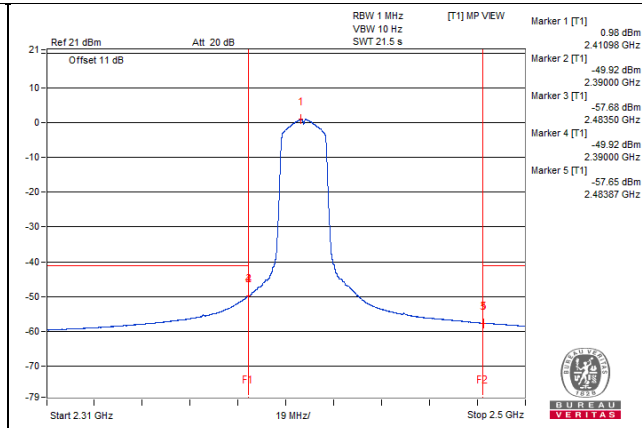
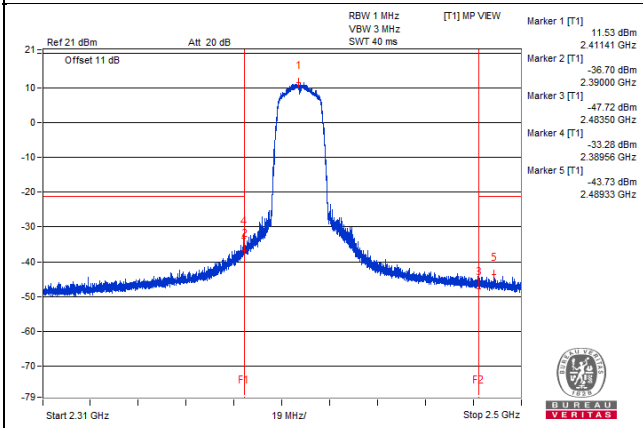

### Chain 1

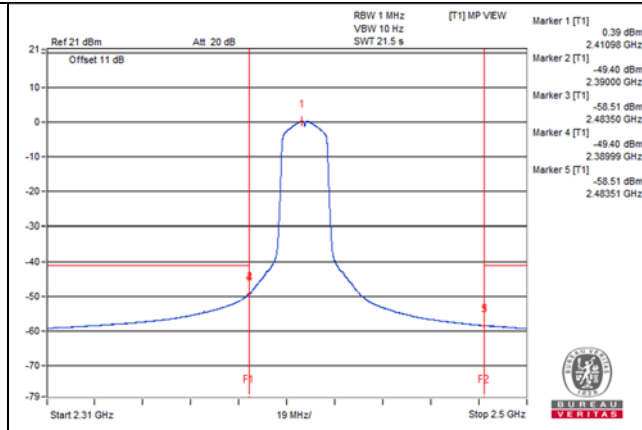
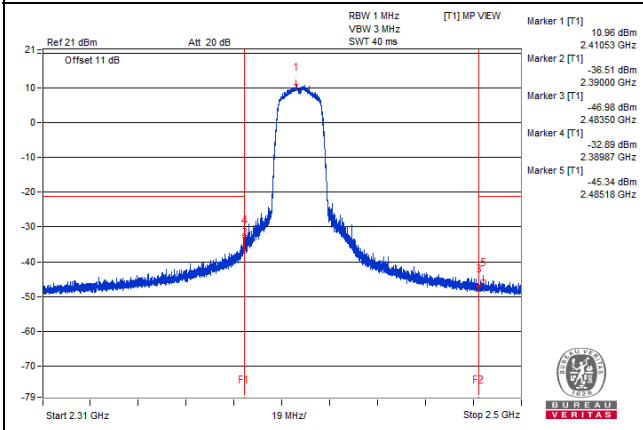

**802.11n (HT20) - Channel 6**  
**Conducted spurious emission table**

**Chain 0**

No.	Frequency (MHz)	Emission Level (dBuV/m)	Limit (dBuV/m)	Margin (dB)	Raw Value (dBm)	Correction Factor (dB)	EIRP Level (dBm)
1	2437.5 PK	111.22	*		10.07	5.89	15.96
2	2343.75 PK	55.13	74	-18.87	-46.02	5.89	-40.13
3	7307.81 PK	54.76	74	-19.24	-46.39	5.89	-40.5
4	21646.31 PK	56.35	#		-44.8	5.89	-38.91
5	2437.5 AV	102.97	*		1.82	5.89	7.71
6	2348.43 AV	42.6	54	-11.4	-58.55	5.89	-52.66
7	2534.37 AV	42.45	#		-58.7	5.89	-52.81
8	21667.87 AV	43.97	#		-57.18	5.89	-51.29

Note :

- Emission Level (dBuV/m) = EIRP Level (dBm) – 20log(d) + 104.8  
 d = measurement distance in 3 meters.
- Correction Factor(dB) = Antenna Gain (dBi) + 10 log ( 2 of TX antenna elements)
- \* : Fundamental frequency, the limit was restricted at the output power.
- # : Non-restricted frequency, the limit was restricted at the conducted out of band emission.

**Chain 1**

No.	Frequency (MHz)	Emission Level (dBuV/m)	Limit (dBuV/m)	Margin (dB)	Raw Value (dBm)	Correction Factor (dB)	EIRP Level (dBm)
1	2435.93 PK	111.27	*		9.38	6.63	16.01
2	2312.5 PK	54.43	74	-19.57	-47.46	6.63	-40.83
3	3665.62 PK	55.08	74	-18.92	-46.81	6.63	-40.18
4	21611.81 PK	56.82	#		-45.07	6.63	-38.44
5	2437.5 AV	102.6	*		0.71	6.63	7.34
6	2348.43 AV	43.63	54	-10.37	-58.26	6.63	-51.63
7	3248.43 AV	43.47	#		-58.42	6.63	-51.79
8	21633.37 AV	44.86	#		-57.03	6.63	-50.4

Note :

- Emission Level (dBuV/m) = EIRP Level (dBm) – 20log(d) + 104.8  
 d = measurement distance in 3 meters.
- Correction Factor(dB) = Antenna Gain (dBi) + 10 log ( 2 of TX antenna elements)
- \* : Fundamental frequency, the limit was restricted at the output power.
- # : Non-restricted frequency, the limit was restricted at the conducted out of band emission.

### Chain 0

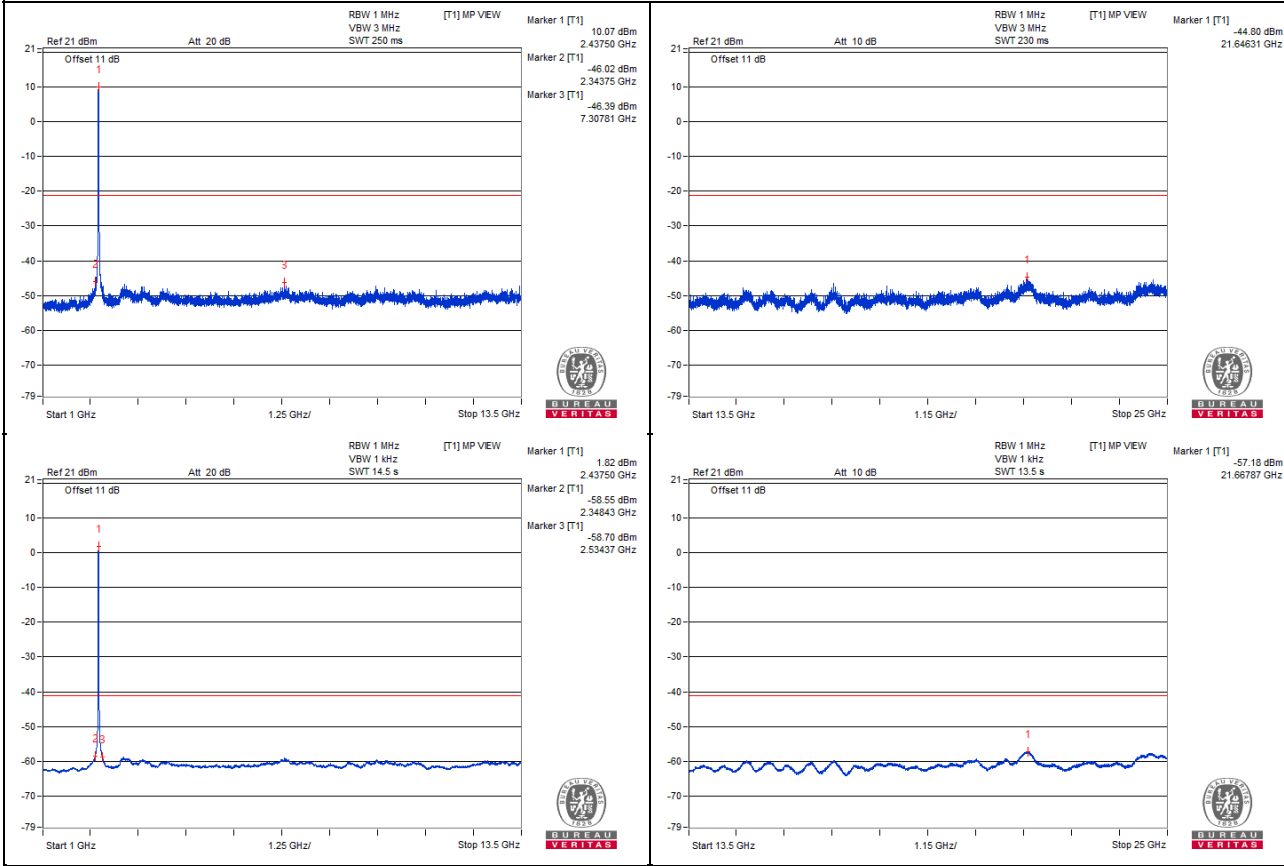

### Chain 1

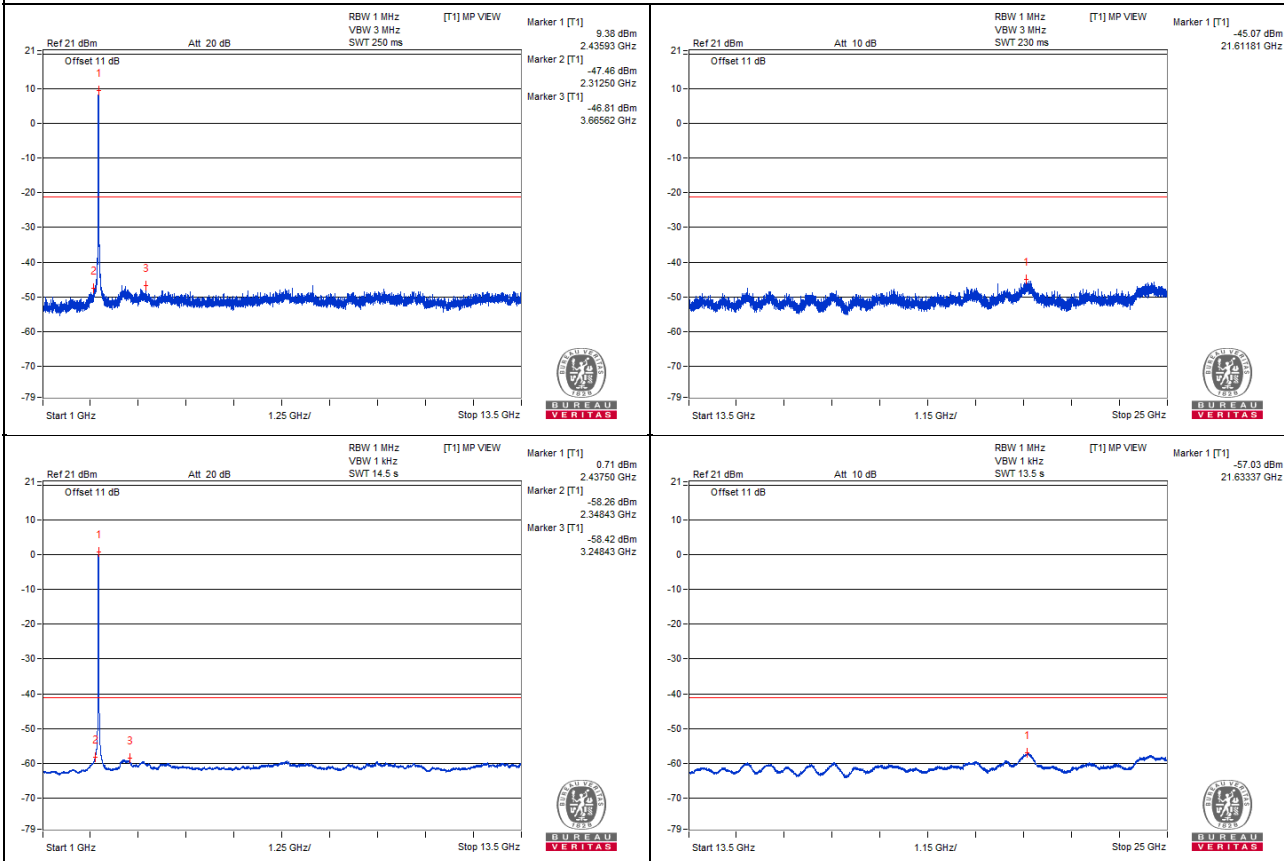

## Bandedge table

### Chain 0

No.	Frequency (MHz)	Emission Level (dBuV/m)	Limit (dBuV/m)	Margin (dB)	Raw Value (dBm)	Correction Factor (dB)	EIRP Level (dBm)
1	2436.35 PK	112.74	*		11.59	5.89	17.48
2	2390 PK	56.86	74	-17.14	-44.29	5.89	-38.4
3	2483.5 PK	56.54	74	-17.46	-44.61	5.89	-38.72
4	2389.84 PK	58.41	74	-15.59	-42.74	5.89	-36.85
5	2486.65 PK	58.96	74	-15.04	-42.19	5.89	-36.3
6	2436.04 AV	102.46	*		1.31	5.89	7.2
7	2390 AV	44.89	54	-9.11	-56.26	5.89	-50.37
8	2483.5 AV	45.12	54	-8.88	-56.03	5.89	-50.14
9	2390 AV	44.89	54	-9.11	-56.26	5.89	-50.37
10	2483.61 AV	45.13	54	-8.87	-56.02	5.89	-50.13

Note :

1. Emission Level (dBuV/m) = EIRP Level (dBm) – 20log(d) + 104.8  
d = measurement distance in 3 meters.
2. Correction Factor(dB) = Antenna Gain (dBi) + 10 log ( 2 of TX antenna elements)
3. \* : Fundamental frequency, the limit was restricted at the output power.

### Chain 1

No.	Frequency (MHz)	Emission Level (dBuV/m)	Limit (dBuV/m)	Margin (dB)	Raw Value (dBm)	Correction Factor (dB)	EIRP Level (dBm)
1	2437.15 PK	112.68	*		10.79	6.63	17.42
2	2390 PK	56.03	74	-17.97	-45.86	6.63	-39.23
3	2483.5 PK	56.83	74	-17.17	-45.06	6.63	-38.43
4	2389.01 PK	59.99	74	-14.01	-41.9	6.63	-35.27
5	2484.13 PK	58.76	74	-15.24	-43.13	6.63	-36.5
6	2436.04 AV	102.4	*		0.51	6.63	7.14
7	2390 AV	46.02	54	-7.98	-55.87	6.63	-49.24
8	2483.5 AV	45.46	54	-8.54	-56.43	6.63	-49.8
9	2389.94 AV	46.03	54	-7.97	-55.86	6.63	-49.23
10	2483.5 AV	45.46	54	-8.54	-56.43	6.63	-49.8

Note :

1. Emission Level (dBuV/m) = EIRP Level (dBm) – 20log(d) + 104.8  
d = measurement distance in 3 meters.
2. Correction Factor(dB) = Antenna Gain (dBi) + 10 log ( 2 of TX antenna elements)
3. \* : Fundamental frequency, the limit was restricted at the output power.

### Chain 0

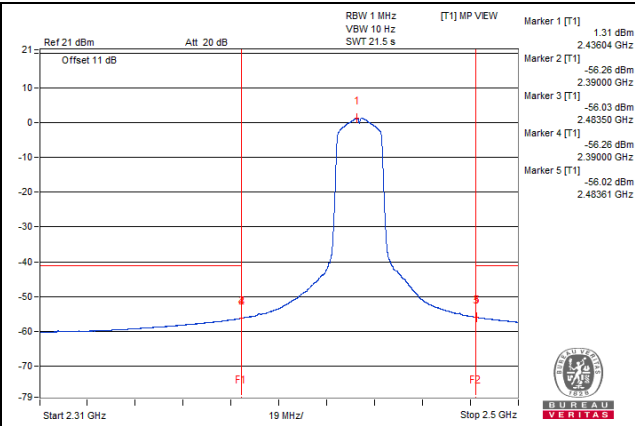
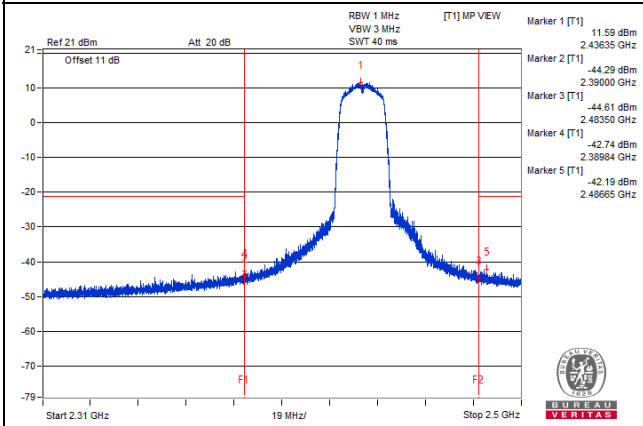

### Chain 1

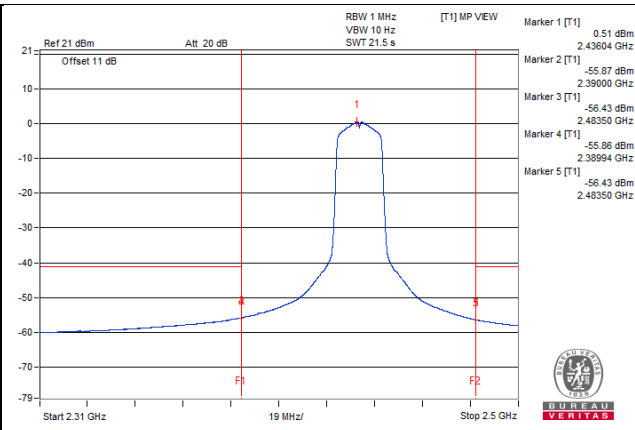
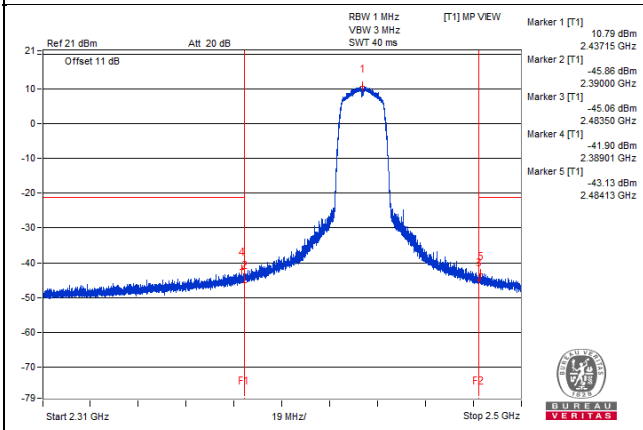



**802.11n (HT20) - Channel 11**  
**Conducted spurious emission table**

**Chain 0**

No.	Frequency (MHz)	Emission Level (dBuV/m)	Limit (dBuV/m)	Margin (dB)	Raw Value (dBm)	Correction Factor (dB)	EIRP Level (dBm)
1	2460.93 PK	111.12	*		9.97	5.89	15.86
2	2306.25 PK	53.06	#		-48.09	5.89	-42.2
3	3115.62 PK	54.04	#		-47.11	5.89	-41.22
4	24555.81 PK	56.53	#		-44.62	5.89	-38.73
5	2460.93 AV	102.38	*		1.23	5.89	7.12
6	2348.43 AV	41.58	54	-12.42	-59.57	5.89	-53.68
7	2534.37 AV	43.33	#		-57.82	5.89	-51.93
8	21643.43 AV	44.06	#		-57.09	5.89	-51.2

Note :

- Emission Level (dBuV/m) = EIRP Level (dBm) – 20log(d) + 104.8  
d = measurement distance in 3 meters.
- Correction Factor(dB) = Antenna Gain (dBi) + 10 log ( 2 of TX antenna elements)
- \* : Fundamental frequency, the limit was restricted at the output power.
- # : Non-restricted frequency, the limit was restricted at the conducted out of band emission.

**Chain 1**

No.	Frequency (MHz)	Emission Level (dBuV/m)	Limit (dBuV/m)	Margin (dB)	Raw Value (dBm)	Correction Factor (dB)	EIRP Level (dBm)
1	2459.37 PK	111.24	*		9.35	6.63	15.98
2	2173.43 PK	53.12	#		-48.77	6.63	-42.14
3	3242.18 PK	54.68	#		-47.21	6.63	-40.58
4	21614.68 PK	57.79	#		-44.1	6.63	-37.47
5	2462.5 AV	102.08	*		0.19	6.63	6.82
6	2350 AV	42.56	54	-11.44	-59.33	6.63	-52.7
7	3282.81 AV	43.48	#		-58.41	6.63	-51.78
8	21643.43 AV	44.92	#		-56.97	6.63	-50.34

Note :

- Emission Level (dBuV/m) = EIRP Level (dBm) – 20log(d) + 104.8  
d = measurement distance in 3 meters.
- Correction Factor(dB) = Antenna Gain (dBi) + 10 log ( 2 of TX antenna elements)
- \* : Fundamental frequency, the limit was restricted at the output power.
- # : Non-restricted frequency, the limit was restricted at the conducted out of band emission.

### Chain 0

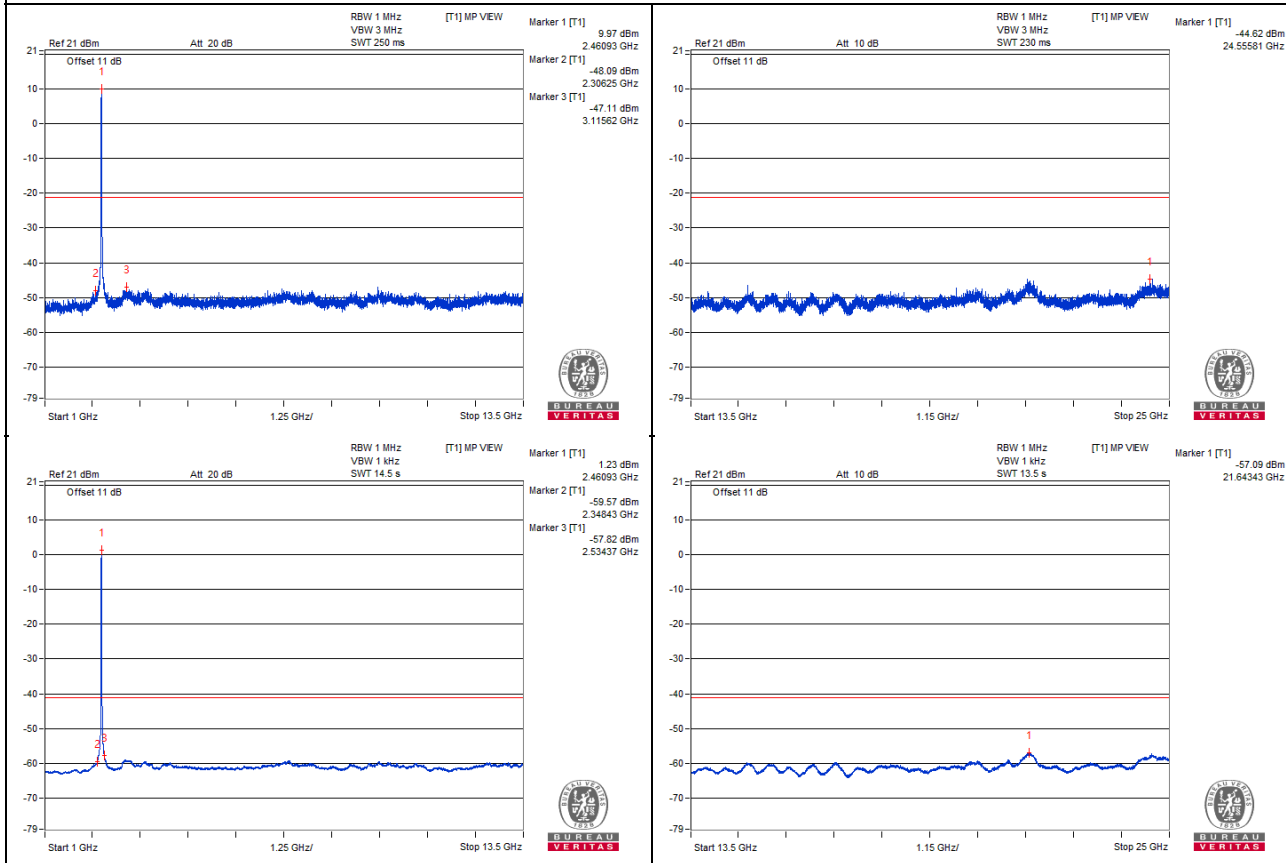

### Chain 1

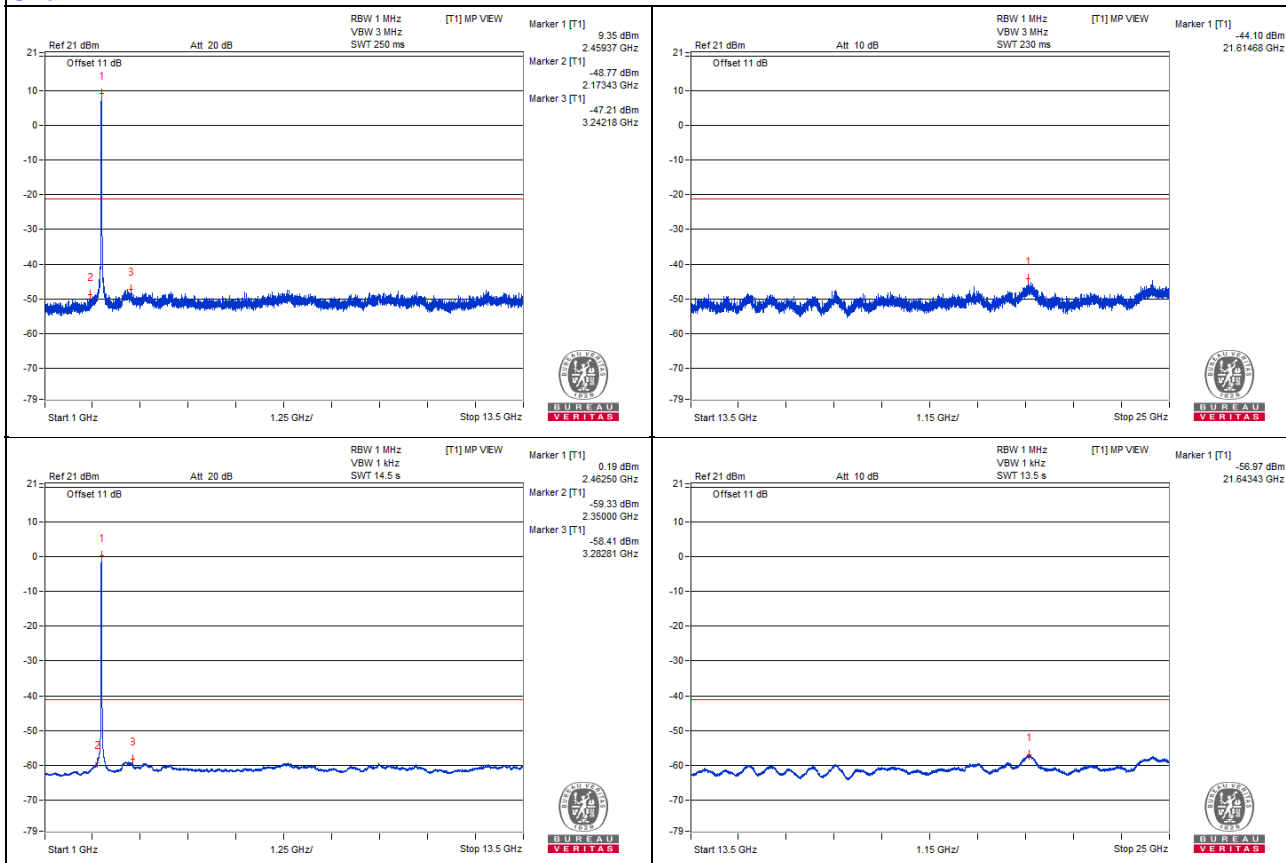

## Bandedge table

### Chain 0

No.	Frequency (MHz)	Emission Level (dBuV/m)	Limit (dBuV/m)	Margin (dB)	Raw Value (dBm)	Correction Factor (dB)	EIRP Level (dBm)
1	2462.14 PK	112.59	*		11.44	5.89	17.33
2	2390 PK	54.69	74	-19.31	-46.46	5.89	-40.57
3	2483.5 PK	66.1	74	-7.9	-35.05	5.89	-29.16
4	2389.13 PK	56.82	74	-17.18	-44.33	5.89	-38.44
5	2483.56 PK	70.68	74	-3.32	-30.47	5.89	-24.58
6	2462.9 AV	101.94	*		0.79	5.89	6.68
7	2390 AV	43.05	54	-10.95	-58.1	5.89	-52.21
8	2483.5 AV	51.84	54	-2.16	-49.31	5.89	-43.42
9	2389.68 AV	43.06	54	-10.94	-58.09	5.89	-52.2
10	2483.5 AV	51.84	54	-2.16	-49.31	5.89	-43.42

Note :

1. Emission Level (dBuV/m) = EIRP Level (dBm) – 20log(d) + 104.8  
d = measurement distance in 3 meters.
2. Correction Factor(dB) = Antenna Gain (dBi) + 10 log ( 2 of TX antenna elements)
3. \* : Fundamental frequency, the limit was restricted at the output power.

### Chain 1

No.	Frequency (MHz)	Emission Level (dBuV/m)	Limit (dBuV/m)	Margin (dB)	Raw Value (dBm)	Correction Factor (dB)	EIRP Level (dBm)
1	2459.86 PK	112.34	*		10.45	6.63	17.08
2	2390 PK	55.63	74	-18.37	-46.26	6.63	-39.63
3	2483.5 PK	67.14	74	-6.86	-34.75	6.63	-28.12
4	2383.93 PK	57.13	74	-16.87	-44.76	6.63	-38.13
5	2483.87 PK	69.61	74	-4.39	-32.28	6.63	-25.65
6	2460.93 AV	101.82	*		-0.07	6.63	6.56
7	2390 AV	43.92	54	-10.08	-57.97	6.63	-51.34
8	2483.5 AV	52.2	54	-1.8	-49.69	6.63	-43.06
9	2390 AV	43.92	54	-10.08	-57.97	6.63	-51.34
10	2483.5 AV	52.2	54	-1.8	-49.69	6.63	-43.06

Note :

1. Emission Level (dBuV/m) = EIRP Level (dBm) – 20log(d) + 104.8  
d = measurement distance in 3 meters.
2. Correction Factor(dB) = Antenna Gain (dBi) + 10 log ( 2 of TX antenna elements)
3. \* : Fundamental frequency, the limit was restricted at the output power.

### Chain 0

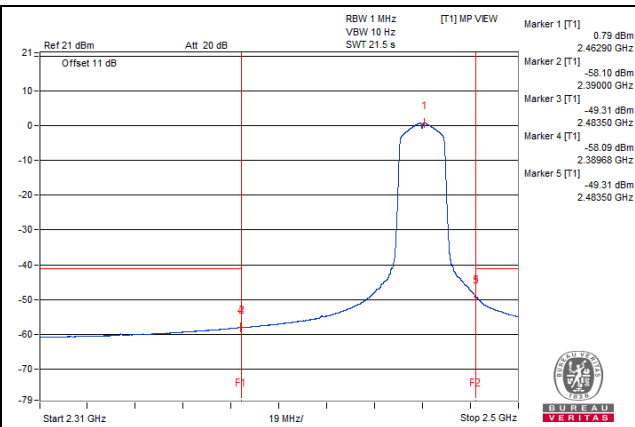
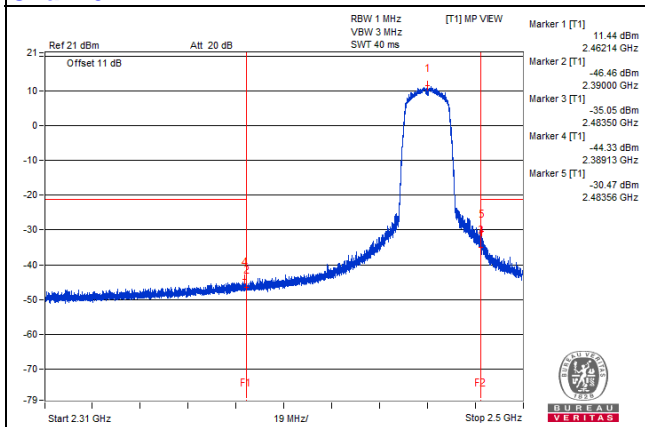

### Chain 1

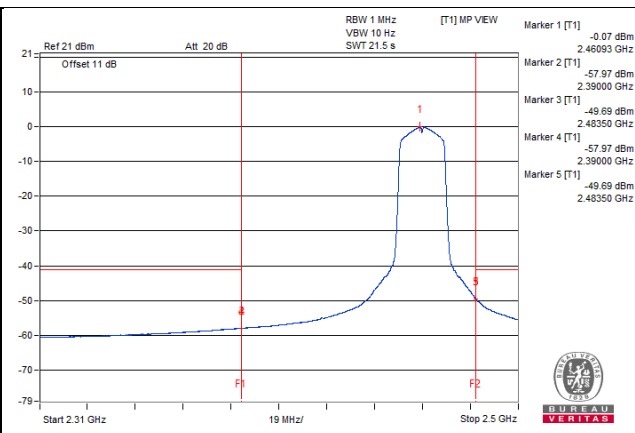
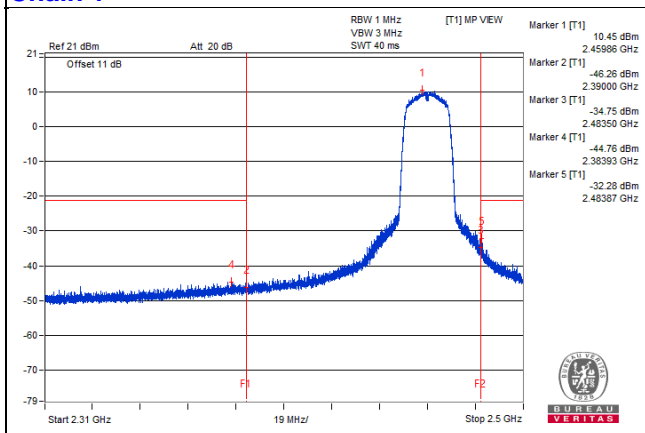

**802.11n (HT40) - Channel 3**  
**Conducted spurious emission table**

**Chain 0**

No.	Frequency (MHz)	Emission Level (dBuV/m)	Limit (dBuV/m)	Margin (dB)	Raw Value (dBm)	Correction Factor (dB)	EIRP Level (dBm)
1	2420.31 PK	108.46	*		7.31	5.89	13.2
2	2348.43 PK	55.28	74	-18.72	-45.87	5.89	-39.98
3	3646.87 PK	54.26	74	-19.74	-46.89	5.89	-41
4	21585.93 PK	56.01	#		-45.14	5.89	-39.25
5	2423.43 AV	99.39	*		-1.76	5.89	4.13
6	2350 AV	42.13	54	-11.87	-59.02	5.89	-53.13
7	3101.56 AV	42.05	#		-59.1	5.89	-53.21
8	21662.12 AV	44.02	#		-57.13	5.89	-51.24

Note :

- Emission Level (dBuV/m) = EIRP Level (dBm) – 20log(d) + 104.8  
d = measurement distance in 3 meters.
- Correction Factor(dB) = Antenna Gain (dBi) + 10 log ( 2 of TX antenna elements)
- \* : Fundamental frequency, the limit was restricted at the output power.
- # : Non-restricted frequency, the limit was restricted at the conducted out of band emission.

**Chain 1**

No.	Frequency (MHz)	Emission Level (dBuV/m)	Limit (dBuV/m)	Margin (dB)	Raw Value (dBm)	Correction Factor (dB)	EIRP Level (dBm)
1	2423.43 PK	108.42	*		6.53	6.63	13.16
2	2350 PK	55.5	74	-18.5	-46.39	6.63	-39.76
3	3207.81 PK	55.08	#		-46.81	6.63	-40.18
4	21675.06 PK	57.53	#		-44.36	6.63	-37.73
5	2420.31 AV	99.6	*		-2.29	6.63	4.34
6	2343.75 AV	44.78	54	-9.22	-57.11	6.63	-50.48
7	3228.12 AV	45.1	#		-56.79	6.63	-50.16
8	21639.12 AV	44.73	#		-57.16	6.63	-50.53

Note :

- Emission Level (dBuV/m) = EIRP Level (dBm) – 20log(d) + 104.8  
d = measurement distance in 3 meters.
- Correction Factor(dB) = Antenna Gain (dBi) + 10 log ( 2 of TX antenna elements)
- \* : Fundamental frequency, the limit was restricted at the output power.
- # : Non-restricted frequency, the limit was restricted at the conducted out of band emission.

### Chain 0

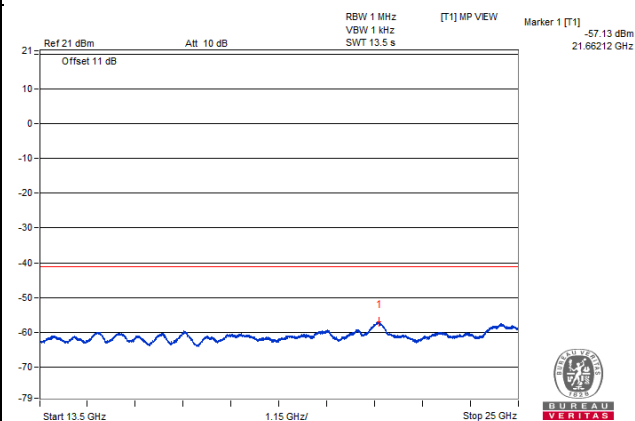
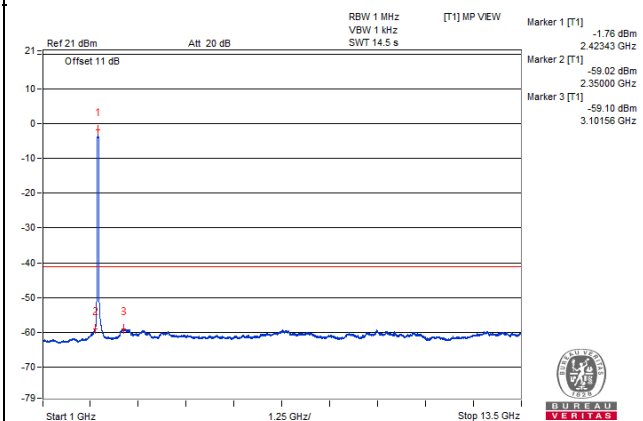
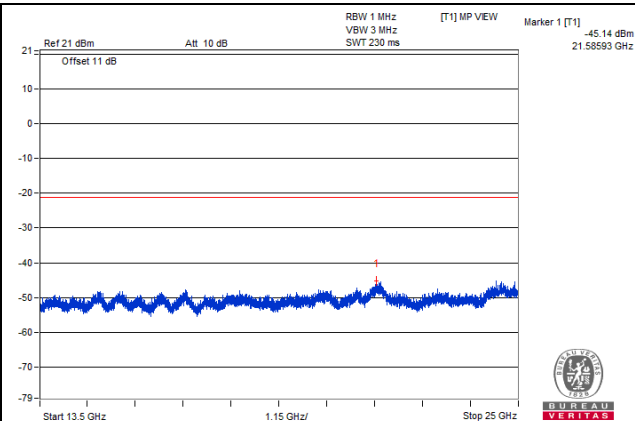
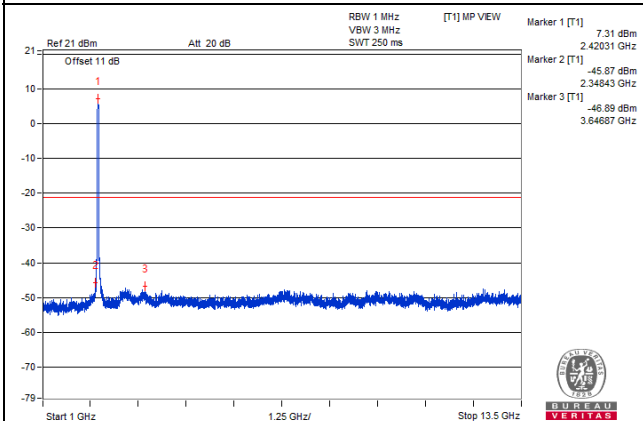

### Chain 1

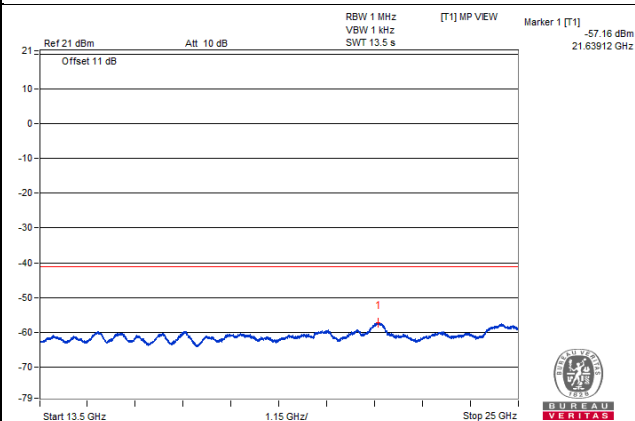
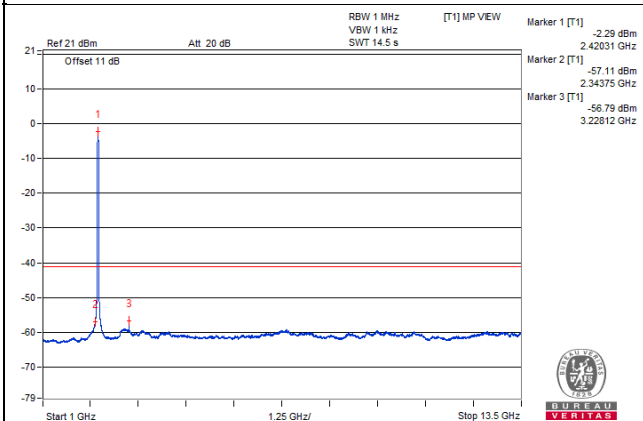
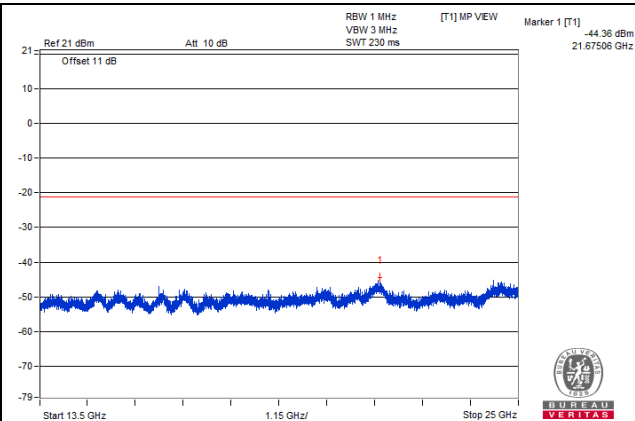
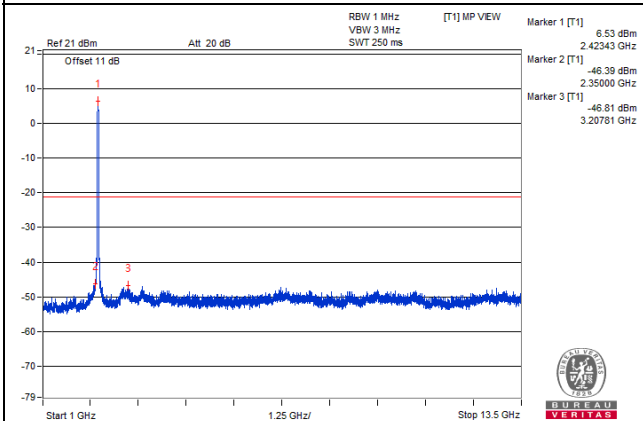

## Bandedge table

### Chain 0

No.	Frequency (MHz)	Emission Level (dBuV/m)	Limit (dBuV/m)	Margin (dB)	Raw Value (dBm)	Correction Factor (dB)	EIRP Level (dBm)
1	2427.72 PK	109.84	*		8.69	5.89	14.58
2	2390 PK	62.85	74	-11.15	-38.3	5.89	-32.41
3	2483.5 PK	55.23	74	-18.77	-45.92	5.89	-40.03
4	2389.82 PK	64.39	74	-9.61	-36.76	5.89	-30.87
5	2488.79 PK	58.83	74	-15.17	-42.32	5.89	-36.43
6	2423.5 AV	99.09	*		-2.06	5.89	3.83
7	2390 AV	51.61	54	-2.39	-49.54	5.89	-43.65
8	2483.5 AV	43.97	54	-10.03	-57.18	5.89	-51.29
9	2389.89 AV	51.64	54	-2.36	-49.51	5.89	-43.62
10	2483.66 AV	44.01	54	-9.99	-57.14	5.89	-51.25

Note :

1. Emission Level (dBuV/m) = EIRP Level (dBm) – 20log(d) + 104.8  
d = measurement distance in 3 meters.
2. Correction Factor(dB) = Antenna Gain (dBi) + 10 log ( 2 of TX antenna elements)
3. \* : Fundamental frequency, the limit was restricted at the output power.

### Chain 1

No.	Frequency (MHz)	Emission Level (dBuV/m)	Limit (dBuV/m)	Margin (dB)	Raw Value (dBm)	Correction Factor (dB)	EIRP Level (dBm)
1	2425.85 PK	109.71	*		7.82	6.63	14.45
2	2390 PK	66.69	74	-7.31	-35.2	6.63	-28.57
3	2483.5 PK	55.56	74	-18.44	-46.33	6.63	-39.7
4	2389.01 PK	67.54	74	-6.46	-34.35	6.63	-27.72
5	2486.13 PK	57.89	74	-16.11	-44	6.63	-37.37
6	2423.4 AV	99.13	*		-2.76	6.63	3.87
7	2390 AV	51.98	54	-2.02	-49.91	6.63	-43.28
8	2483.5 AV	44.58	54	-9.42	-57.31	6.63	-50.68
9	2389.87 AV	52.03	54	-1.97	-49.86	6.63	-43.23
10	2483.51 AV	44.59	54	-9.41	-57.3	6.63	-50.67

Note :

1. Emission Level (dBuV/m) = EIRP Level (dBm) – 20log(d) + 104.8  
d = measurement distance in 3 meters.
2. Correction Factor(dB) = Antenna Gain (dBi) + 10 log ( 2 of TX antenna elements)
3. \* : Fundamental frequency, the limit was restricted at the output power.

### Chain 0

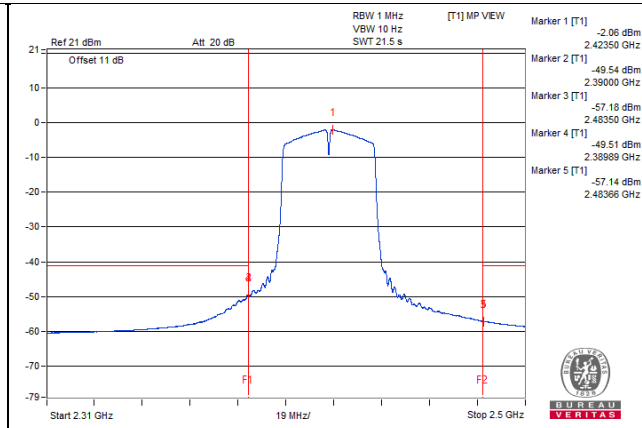
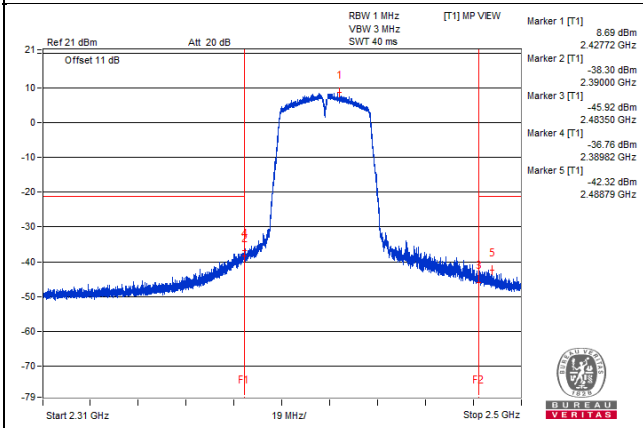

### Chain 1

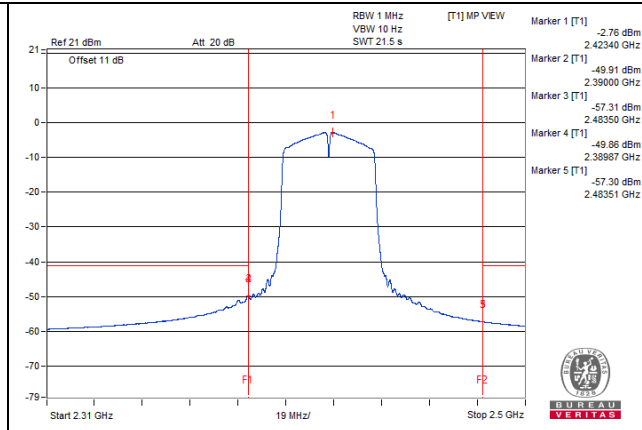
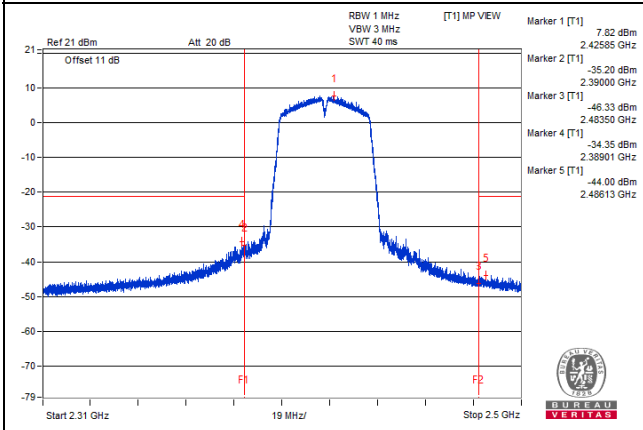



**802.11n (HT40) - Channel 6**  
**Conducted spurious emission table**

**Chain 0**

No.	Frequency (MHz)	Emission Level (dBuV/m)	Limit (dBuV/m)	Margin (dB)	Raw Value (dBm)	Correction Factor (dB)	EIRP Level (dBm)
1	2439.06 PK	109.08	*		7.93	5.89	13.82
2	2346.87 PK	54.52	74	-19.48	-46.63	5.89	-40.74
3	7292.18 PK	53.8	74	-20.2	-47.35	5.89	-41.46
4	21634.81 PK	55.45	#		-45.7	5.89	-39.81
5	2437.5 AV	100.29	*		-0.86	5.89	5.03
6	2350 AV	42.77	54	-11.23	-58.38	5.89	-52.49
7	2533.5 AV	42.58	#		-58.57	5.89	-52.68
8	21647.75 AV	43.97	#		-57.18	5.89	-51.29

Note :

- Emission Level (dBuV/m) = EIRP Level (dBm) – 20log(d) + 104.8  
 d = measurement distance in 3 meters.
- Correction Factor(dB) = Antenna Gain (dBi) + 10 log ( 2 of TX antenna elements)
- \* : Fundamental frequency, the limit was restricted at the output power.
- # : Non-restricted frequency, the limit was restricted at the conducted out of band emission.

**Chain 1**

No.	Frequency (MHz)	Emission Level (dBuV/m)	Limit (dBuV/m)	Margin (dB)	Raw Value (dBm)	Correction Factor (dB)	EIRP Level (dBm)
1	2437.5 PK	109.43	*		7.54	6.63	14.17
2	2318.75 PK	55.13	74	-18.87	-46.76	6.63	-40.13
3	3196.87 PK	55.12	#		-46.77	6.63	-40.14
4	21630.5 PK	56.79	#		-45.1	6.63	-38.47
5	2439.06 AV	100.24	*		-1.65	6.63	4.98
6	2350 AV	43.99	54	-10.01	-57.9	6.63	-51.27
7	3248.43 AV	44.99	#		-56.9	6.63	-50.27
8	21624.75 AV	44.94	#		-56.95	6.63	-50.32

Note :

- Emission Level (dBuV/m) = EIRP Level (dBm) – 20log(d) + 104.8  
 d = measurement distance in 3 meters.
- Correction Factor(dB) = Antenna Gain (dBi) + 10 log ( 2 of TX antenna elements)
- \* : Fundamental frequency, the limit was restricted at the output power.
- # : Non-restricted frequency, the limit was restricted at the conducted out of band emission.

### Chain 0

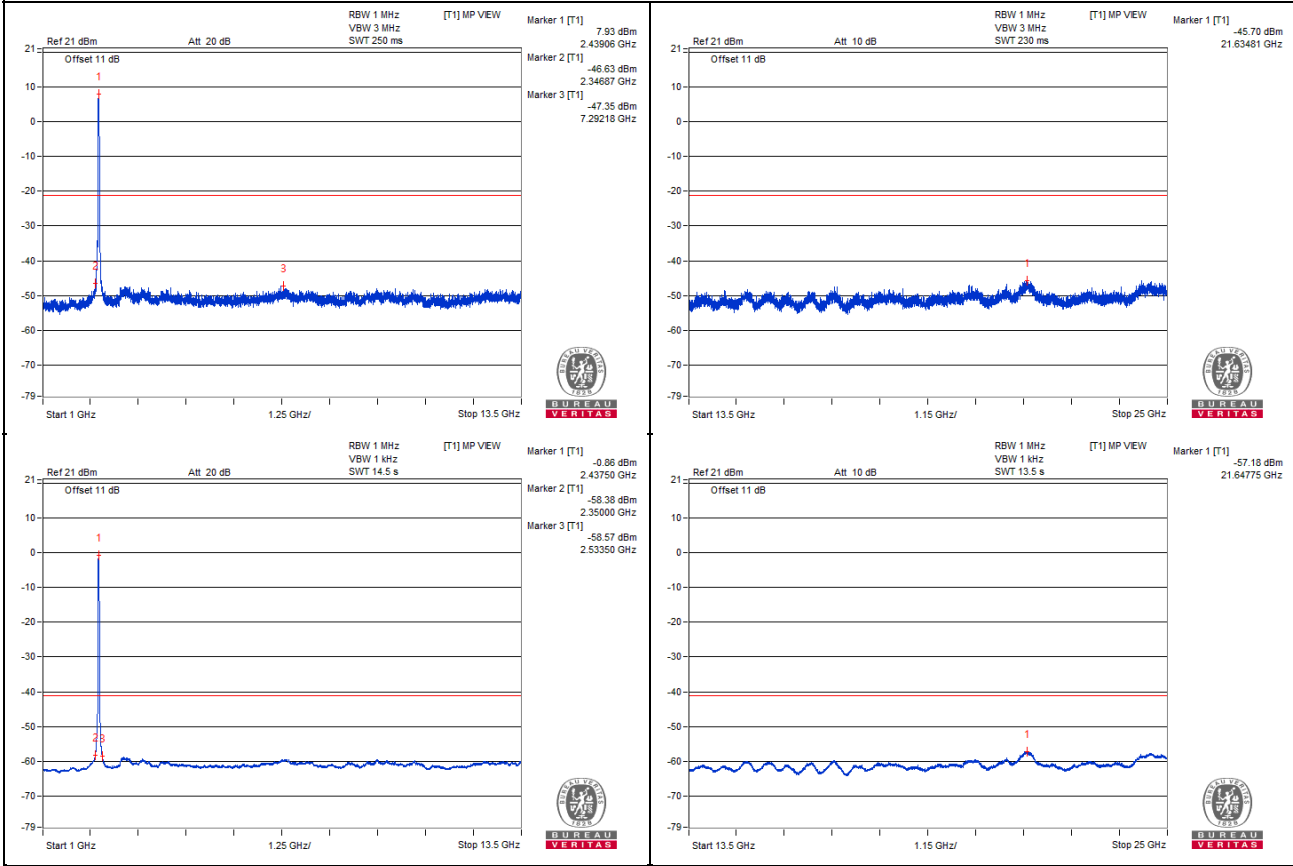

### Chain 1

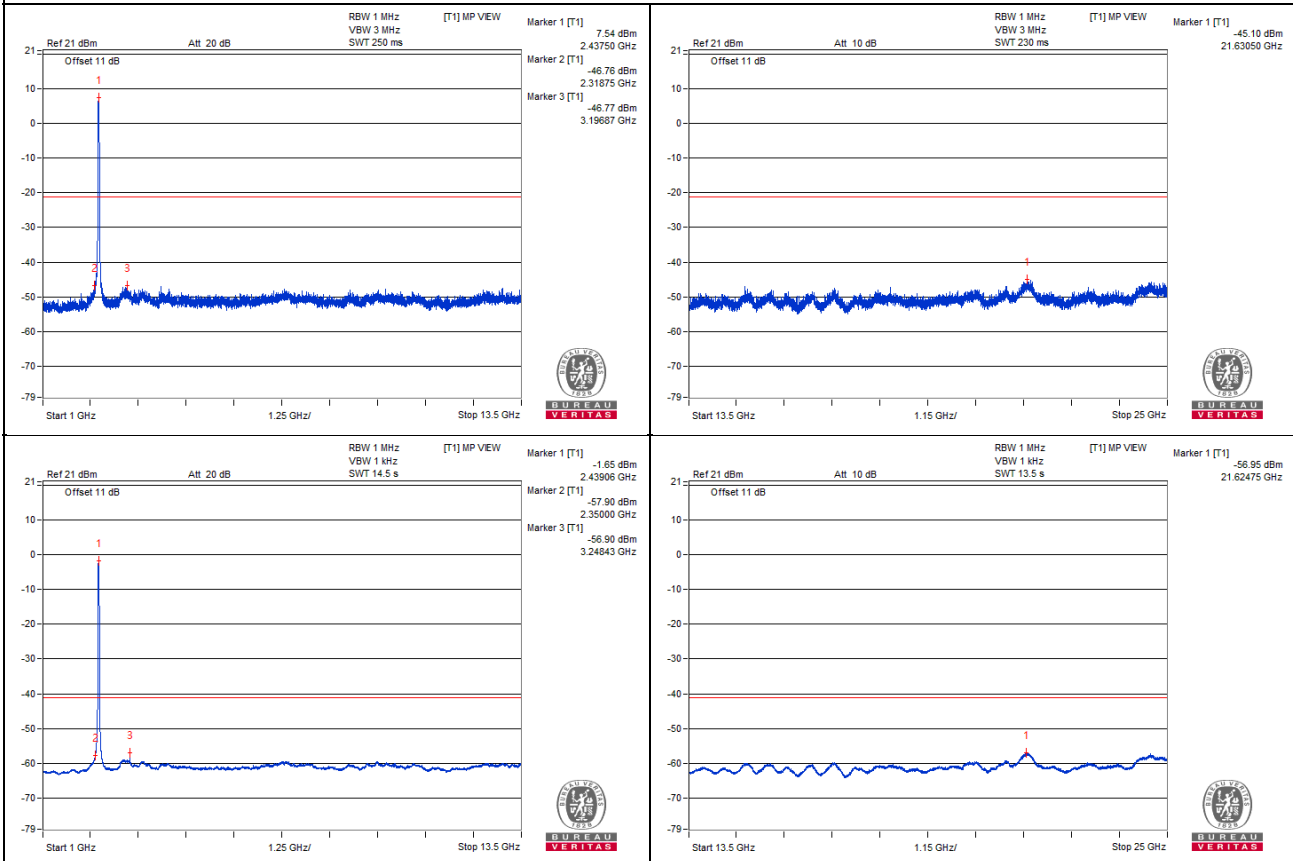

## Bandedge table

### Chain 0

No.	Frequency (MHz)	Emission Level (dBuV/m)	Limit (dBuV/m)	Margin (dB)	Raw Value (dBm)	Correction Factor (dB)	EIRP Level (dBm)
1	2433.54 PK	110.77	*		9.62	5.89	15.51
2	2390 PK	59.87	74	-14.13	-41.28	5.89	-35.39
3	2483.5 PK	60.43	74	-13.57	-40.72	5.89	-34.83
4	2389.11 PK	61.39	74	-12.61	-39.76	5.89	-33.87
5	2484.37 PK	62.61	74	-11.39	-38.54	5.89	-32.65
6	2435.4 AV	99.62	*		-1.53	5.89	4.36
7	2390 AV	47.94	54	-6.06	-53.21	5.89	-47.32
8	2483.5 AV	48.88	54	-5.12	-52.27	5.89	-46.38
9	2390 AV	47.94	54	-6.06	-53.21	5.89	-47.32
10	2483.5 AV	48.87	54	-5.13	-52.28	5.89	-46.39

Note :

1. Emission Level (dBuV/m) = EIRP Level (dBm) – 20log(d) + 104.8  
d = measurement distance in 3 meters.
2. Correction Factor(dB) = Antenna Gain (dBi) + 10 log ( 2 of TX antenna elements)
3. \* : Fundamental frequency, the limit was restricted at the output power.

### Chain 1

No.	Frequency (MHz)	Emission Level (dBuV/m)	Limit (dBuV/m)	Margin (dB)	Raw Value (dBm)	Correction Factor (dB)	EIRP Level (dBm)
1	2439.22 PK	110.44	*		8.55	6.63	15.18
2	2390 PK	59.73	74	-14.27	-42.16	6.63	-35.53
3	2483.5 PK	60.19	74	-13.81	-41.7	6.63	-35.07
4	2389.01 PK	62.21	74	-11.79	-39.68	6.63	-33.05
5	2484.13 PK	61.57	74	-12.43	-40.32	6.63	-33.69
6	2435.42 AV	99.69	*		-2.2	6.63	4.43
7	2390 AV	48.22	54	-5.78	-53.67	6.63	-47.04
8	2483.5 AV	47.88	54	-6.12	-54.01	6.63	-47.38
9	2390 AV	48.23	54	-5.77	-53.66	6.63	-47.03
10	2483.5 AV	47.88	54	-6.12	-54.01	6.63	-47.38

Note :

1. Emission Level (dBuV/m) = EIRP Level (dBm) – 20log(d) + 104.8  
d = measurement distance in 3 meters.
2. Correction Factor(dB) = Antenna Gain (dBi) + 10 log ( 2 of TX antenna elements)
3. \* : Fundamental frequency, the limit was restricted at the output power.

### Chain 0

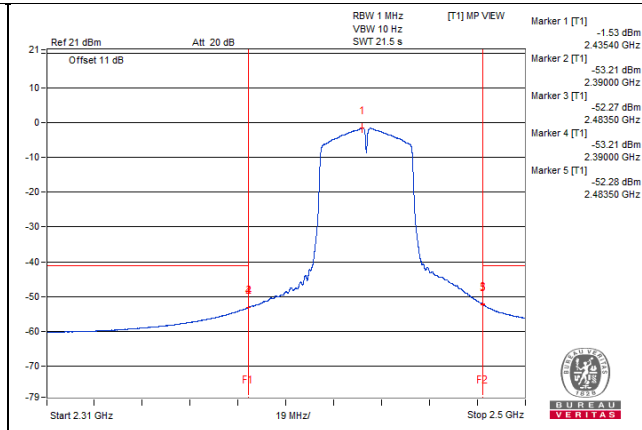
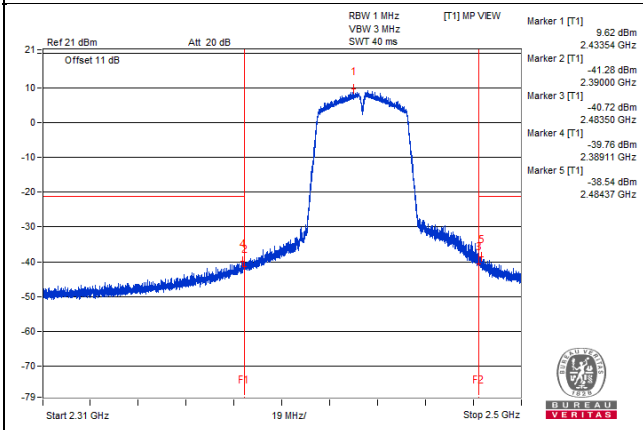

### Chain 1

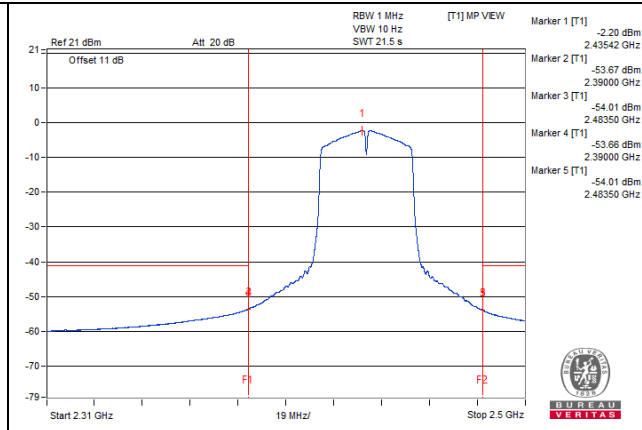
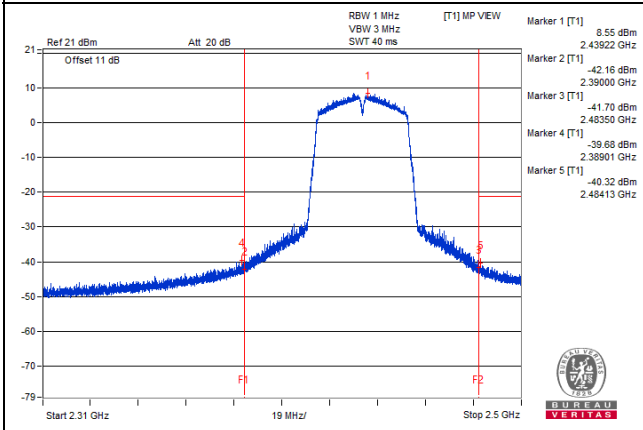

## 802.11n (HT40) - Channel 9

### Conducted spurious emission table

#### Chain 0

No.	Frequency (MHz)	Emission Level (dBuV/m)	Limit (dBuV/m)	Margin (dB)	Raw Value (dBm)	Correction Factor (dB)	EIRP Level (dBm)
1	2453.12 PK	108.98	*		7.83	5.89	13.72
2	2290.62 PK	52.05	74	-21.95	-49.1	5.89	-43.21
3	2535.93 PK	53.83	#		-47.32	5.89	-41.43
4	21672.18 PK	56	#		-45.15	5.89	-39.26
5	2450 AV	99.68	*		-1.47	5.89	4.42
6	2348.43 AV	41.21	54	-12.79	-59.94	5.89	-54.05
7	2539.06 AV	42.44	#		-58.71	5.89	-52.82
8	21642 AV	44.13	#		-57.02	5.89	-51.13

Note :

- Emission Level (dBuV/m) = EIRP Level (dBm) – 20log(d) + 104.8  
d = measurement distance in 3 meters.
- Correction Factor(dB) = Antenna Gain (dBi) + 10 log ( 2 of TX antenna elements)
- \* : Fundamental frequency, the limit was restricted at the output power.
- # : Non-restricted frequency, the limit was restricted at the conducted out of band emission.

#### Chain 1

No.	Frequency (MHz)	Emission Level (dBuV/m)	Limit (dBuV/m)	Margin (dB)	Raw Value (dBm)	Correction Factor (dB)	EIRP Level (dBm)
1	2446.87 PK	107.5	*		5.61	6.63	12.24
2	2290.62 PK	53.12	74	-20.88	-48.77	6.63	-42.14
3	3120.31 PK	54.67	#		-47.22	6.63	-40.59
4	21673.62 PK	56.57	#		-45.32	6.63	-38.69
5	2450 AV	98.59	*		-3.3	6.63	3.33
6	2350 AV	42.02	54	-11.98	-59.87	6.63	-53.24
7	3268.75 AV	42.97	#		-58.92	6.63	-52.29
8	21631.93 AV	44.94	#		-56.95	6.63	-50.32

Note :

- Emission Level (dBuV/m) = EIRP Level (dBm) – 20log(d) + 104.8  
d = measurement distance in 3 meters.
- Correction Factor(dB) = Antenna Gain (dBi) + 10 log ( 2 of TX antenna elements)
- \* : Fundamental frequency, the limit was restricted at the output power.
- # : Non-restricted frequency, the limit was restricted at the conducted out of band emission.

### Chain 0

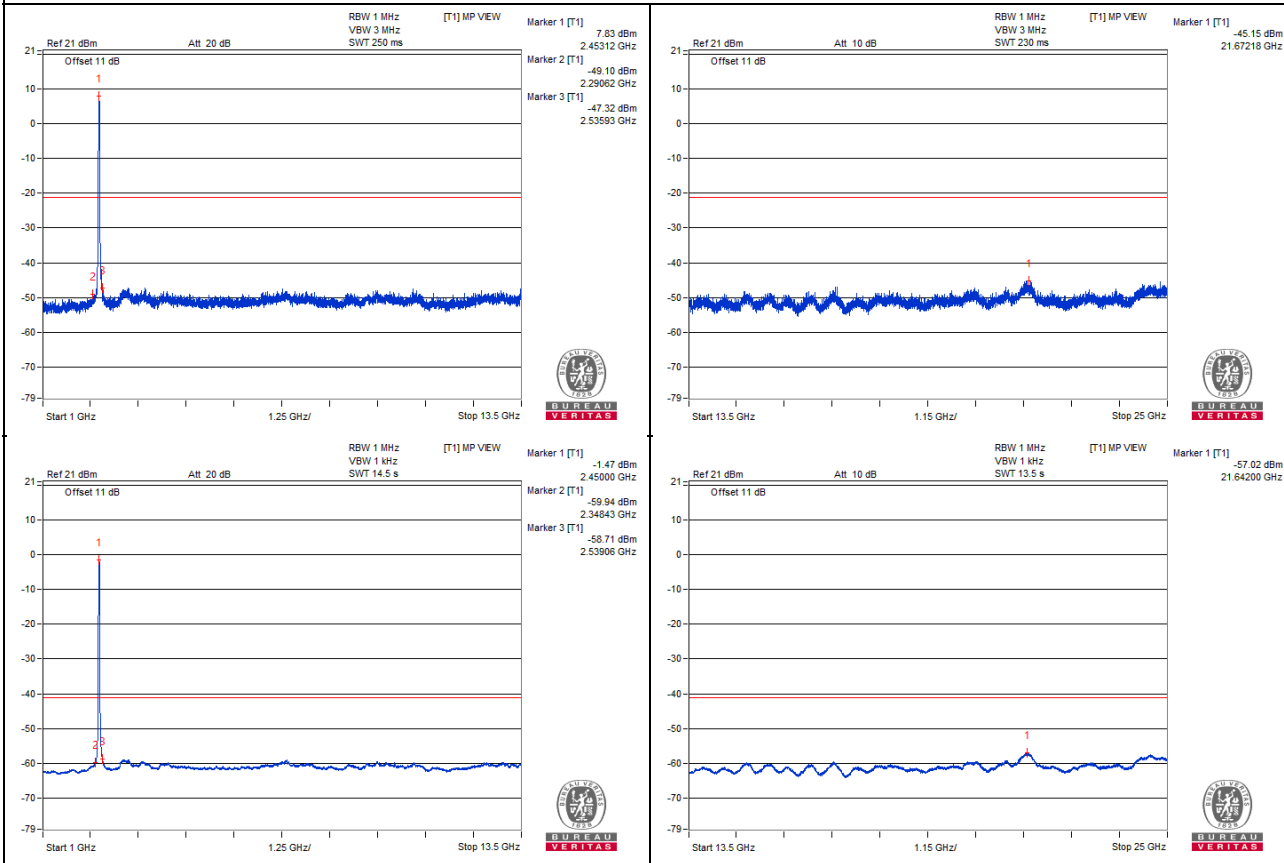

### Chain 1

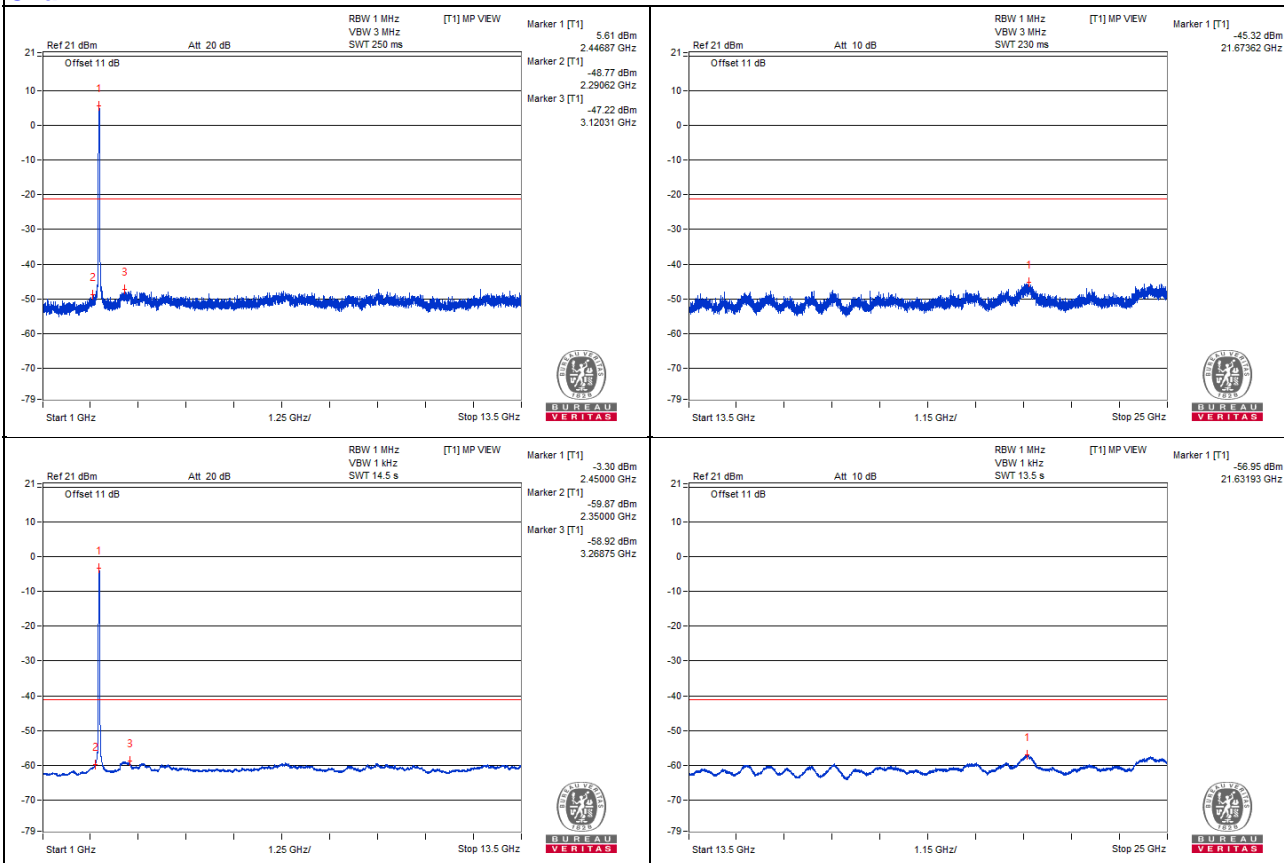

## Bandedge table

### Chain 0

No.	Frequency (MHz)	Emission Level (dBuV/m)	Limit (dBuV/m)	Margin (dB)	Raw Value (dBm)	Correction Factor (dB)	EIRP Level (dBm)
1	2447.03 PK	109.87	*		8.72	5.89	14.61
2	2390 PK	53.93	74	-20.07	-47.22	5.89	-41.33
3	2483.5 PK	62.4	74	-11.6	-38.75	5.89	-32.86
4	2389.39 PK	56.28	74	-17.72	-44.87	5.89	-38.98
5	2486.32 PK	65.96	74	-8.04	-35.19	5.89	-29.3
6	2453.45 AV	99.27	*		-1.88	5.89	4.01
7	2390 AV	42.6	54	-11.4	-58.55	5.89	-52.66
8	2483.5 AV	50.18	54	-3.82	-50.97	5.89	-45.08
9	2389.37 AV	42.62	54	-11.38	-58.53	5.89	-52.64
10	2484.08 AV	50.89	54	-3.11	-50.26	5.89	-44.37

Note :

1. Emission Level (dBuV/m) = EIRP Level (dBm) – 20log(d) + 104.8  
d = measurement distance in 3 meters.
2. Correction Factor(dB) = Antenna Gain (dBi) + 10 log ( 2 of TX antenna elements)
3. \* : Fundamental frequency, the limit was restricted at the output power.

### Chain 1

No.	Frequency (MHz)	Emission Level (dBuV/m)	Limit (dBuV/m)	Margin (dB)	Raw Value (dBm)	Correction Factor (dB)	EIRP Level (dBm)
1	2449.88 PK	109.81	*		7.92	6.63	14.55
2	2390 PK	56.44	74	-17.56	-45.45	6.63	-38.82
3	2483.5 PK	60.36	74	-13.64	-41.53	6.63	-34.9
4	2378.99 PK	58.24	74	-15.76	-43.65	6.63	-37.02
5	2484.18 PK	62.26	74	-11.74	-39.63	6.63	-33
6	2450.36 AV	99.15	*		-2.74	6.63	3.89
7	2390 AV	44.53	54	-9.47	-57.36	6.63	-50.73
8	2483.5 AV	48.36	54	-5.64	-53.53	6.63	-46.9
9	2389.94 AV	44.55	54	-9.45	-57.34	6.63	-50.71
10	2484.15 AV	49.28	54	-4.72	-52.61	6.63	-45.98

Note :

1. Emission Level (dBuV/m) = EIRP Level (dBm) – 20log(d) + 104.8  
d = measurement distance in 3 meters.
2. Correction Factor(dB) = Antenna Gain (dBi) + 10 log ( 2 of TX antenna elements)
3. \* : Fundamental frequency, the limit was restricted at the output power.

### Chain 0

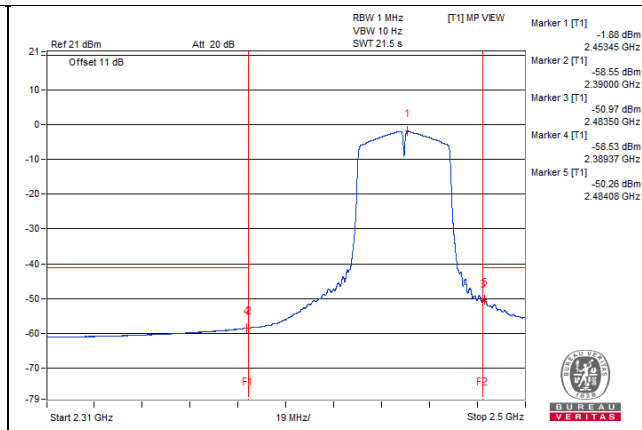
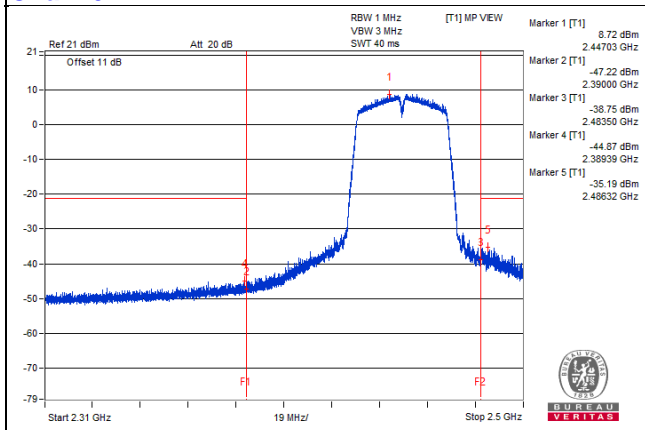

### Chain 1

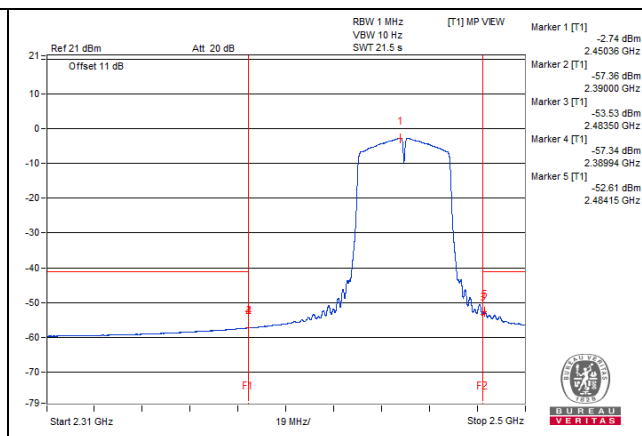
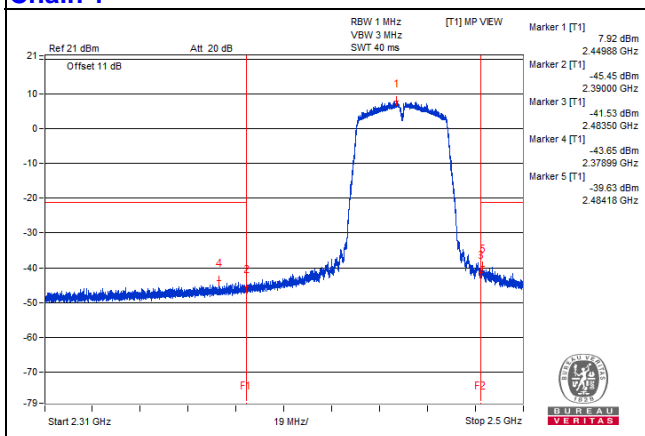



### Below 1GHz Data

### 802.11n (HT20) - Channel 6

### Conducted spurious emission table

#### Chain 0

No.	Frequency (MHz)	Emission Level (dBuV/m)	Limit (dBuV/m)	Margin (dB)	Raw Value (dBm)	Correction Factor (dB)	EIRP Level (dBm)
1	35.09	36.62	#		-64.53	5.89	-58.64
2	107.6	38.67	#		-62.48	5.89	-56.59
3	850.01	38.42	46	-7.58	-62.73	5.89	-56.84
4	967.86	36.97	54	-17.03	-64.18	5.89	-58.29

Note :

- Emission Level (dBuV/m) = EIRP Level (dBm) – 20log(d) + 104.8  
d = measurement distance in 3 meters.
- Correction Factor(dB) = Antenna Gain (dBi) + 10 log ( 2 of TX antenna elements)
- # : Non-restricted frequency, the limit was restricted at the conducted out of band emission.

#### Chain 1

No.	Frequency (MHz)	Emission Level (dBuV/m)	Limit (dBuV/m)	Margin (dB)	Raw Value (dBm)	Correction Factor (dB)	EIRP Level (dBm)
1	37.76	38.2	40	-1.8	-63.69	6.63	-57.06
2	151.61	38.19	#		-63.7	6.63	-57.07
3	567.25	38.92	#		-62.97	6.63	-56.34
4	993.08	37.98	54	-16.02	-63.91	6.63	-57.28

Note :

- Emission Level (dBuV/m) = EIRP Level (dBm) – 20log(d) + 104.8  
d = measurement distance in 3 meters.
- Correction Factor(dB) = Antenna Gain (dBi) + 10 log ( 2 of TX antenna elements)
- # : Non-restricted frequency, the limit was restricted at the conducted out of band emission.

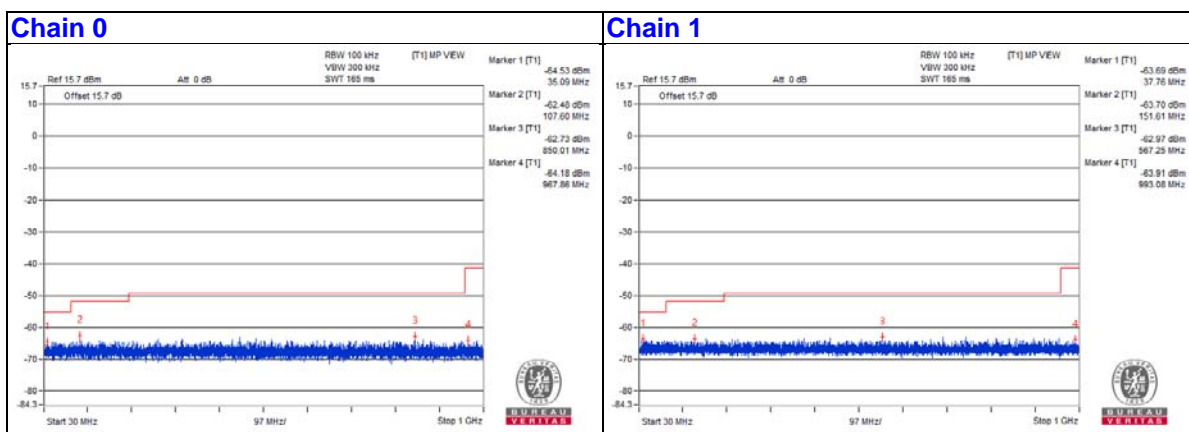

Note: Choose worse case from above and set RBW/VBW=120kHz/1MHz to verification.

**802.11n (HT20) - Channel 6**

**Conducted spurious emission table**

**Chain 0**

No.	Frequency (MHz)	Emission Level (dBuV/m)	Limit (dBuV/m)	Margin (dB)	Raw Value (dBm)	Correction Factor (dB)	EIRP Level (dBm)
1	58.73	35.99	#		-65.16	5.89	-59.27
2	150.64	36.45	#		-64.7	5.89	-58.81
3	814.12	37.94	#		-63.21	5.89	-57.32
4	982.17	38.05	54	-15.95	-63.1	5.89	-57.21

Note :

- Emission Level (dBuV/m) = EIRP Level (dBm) – 20log(d) + 104.8  
d = measurement distance in 3 meters.
- Correction Factor(dB) = Antenna Gain (dBi) + 10 log ( 2 of TX antenna elements)
- # : Non-restricted frequency, the limit was restricted at the conducted out of band emission.

**Chain 1**

No.	Frequency (MHz)	Emission Level (dBuV/m)	Limit (dBuV/m)	Margin (dB)	Raw Value (dBm)	Correction Factor (dB)	EIRP Level (dBm)
1	42.97	36.55	#		-65.34	6.63	-58.71
2	188.71	36.51	#		-65.38	6.63	-58.75
3	895.84	38.63	46	-7.37	-63.26	6.63	-56.63
4	964.95	38.33	54	-15.67	-63.56	6.63	-56.93

Note :

- Emission Level (dBuV/m) = EIRP Level (dBm) – 20log(d) + 104.8  
d = measurement distance in 3 meters.
- Correction Factor(dB) = Antenna Gain (dBi) + 10 log ( 2 of TX antenna elements)
- # : Non-restricted frequency, the limit was restricted at the conducted out of band emission.

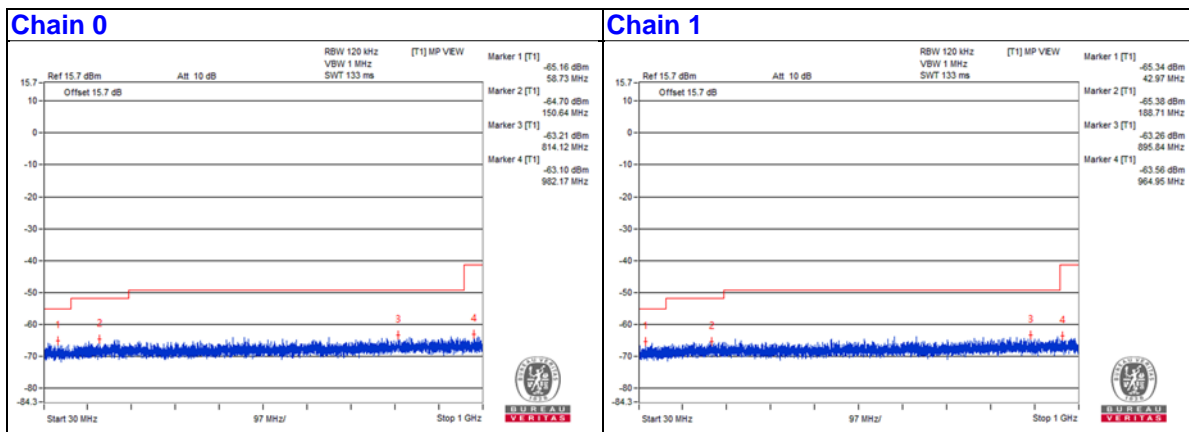

4.1.8.2 Test Results (Mode 2)

802.11b - Channel 1

Conducted spurious emission table

No.	Frequency (MHz)	Emission Level (dBuV/m)	Limit (dBuV/m)	Margin (dB)	Raw Value (dBm)	Correction Factor (dB)	EIRP Level (dBm)
1	2412.5 PK	108.99	*		10.85	2.88	13.73
2	2340.62 PK	50.4	74	-23.6	-47.74	2.88	-44.86
3	3073.43 PK	52.17	#		-45.97	2.88	-43.09
4	21660.68 PK	53.63	#		-44.51	2.88	-41.63
5	2410.93 AV	105.19	*		7.05	2.88	9.93
6	2343.75 AV	38.68	54	-15.32	-59.46	2.88	-56.58
7	3107.81 AV	39.72	#		-58.42	2.88	-55.54
8	21634.81 AV	42.01	#		-56.13	2.88	-53.25

Note :

- Emission Level (dBuV/m) = EIRP Level (dBm) – 20log(d) + 104.8  
d = measurement distance in 3 meters.
- \* : Fundamental frequency, the limit was restricted at the output power.
- # : Non-restricted frequency, the limit was restricted at the conducted out of band emission.

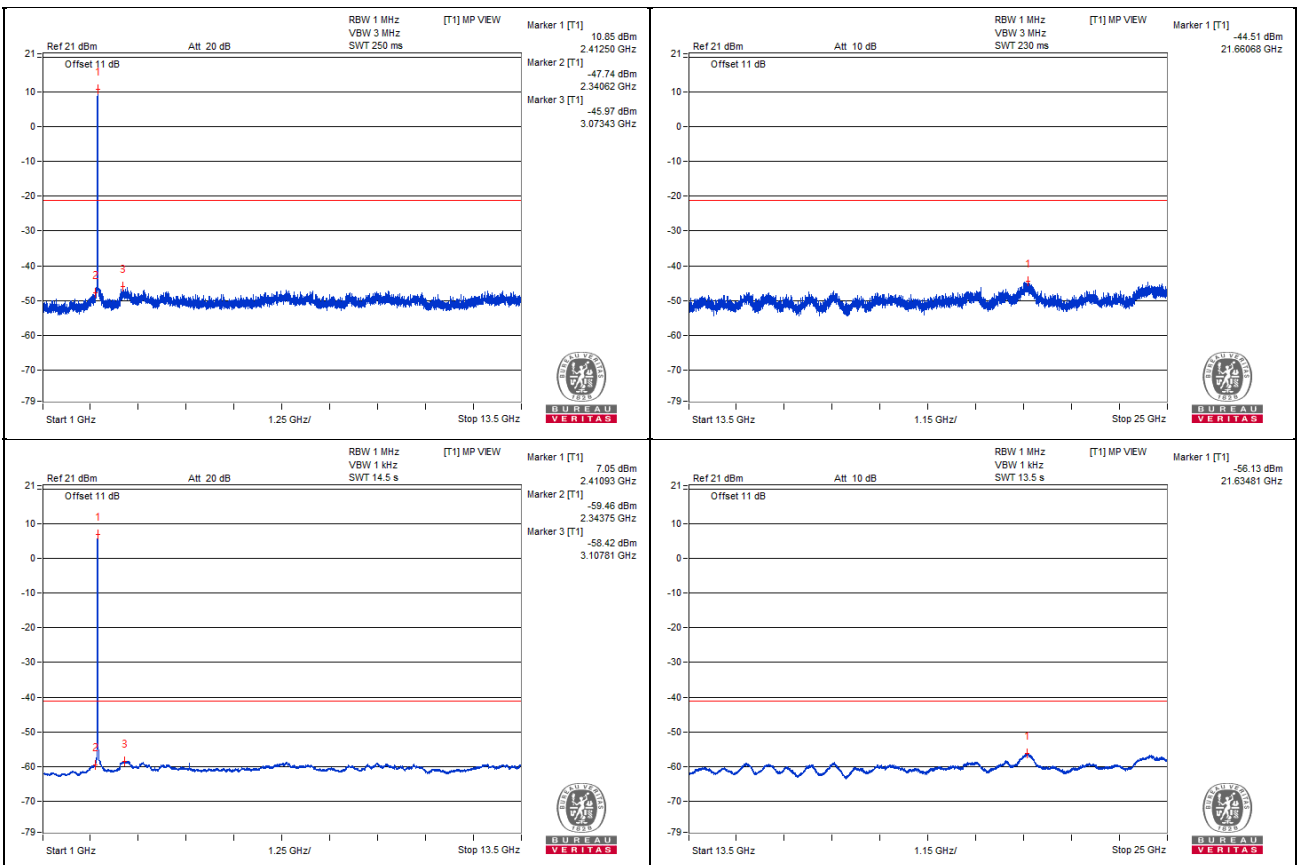

### Bandedge table

No.	Frequency (MHz)	Emission Level (dBuV/m)	Limit (dBuV/m)	Margin (dB)	Raw Value (dBm)	Correction Factor (dB)	EIRP Level (dBm)
1	2412.98 PK	109.13	*		10.99	2.88	13.87
2	2390 PK	51.64	74	-22.36	-46.5	2.88	-43.62
3	2483.5 PK	48.55	74	-25.45	-49.59	2.88	-46.71
4	2388.51 PK	53.6	74	-20.4	-44.54	2.88	-41.66
5	2484.46 PK	52.48	74	-21.52	-45.66	2.88	-42.78
6	2411.22 AV	105.15	*		7.01	2.88	9.89
7	2390 AV	41.04	54	-12.96	-57.1	2.88	-54.22
8	2483.5 AV	38.42	54	-15.58	-59.72	2.88	-56.84
9	2389.94 AV	41.04	54	-12.96	-57.1	2.88	-54.22
10	2491.99 AV	39.06	54	-14.94	-59.08	2.88	-56.2

Note :

- Emission Level (dBuV/m) = EIRP Level (dBm) – 20log(d) + 104.8  
d = measurement distance in 3 meters.
- \* : Fundamental frequency, the limit was restricted at the output power.

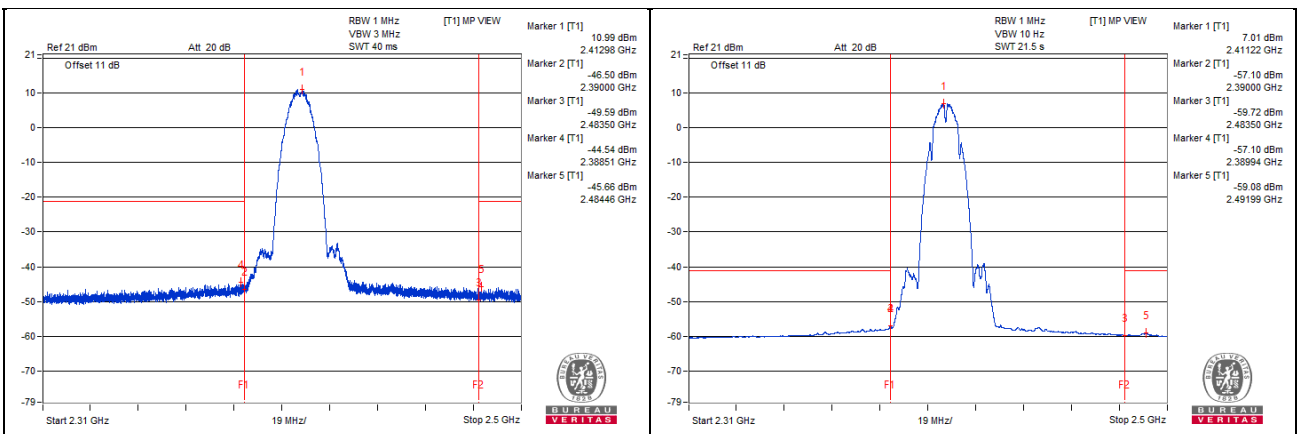

### 802.11b - Channel 6

#### Conducted spurious emission table

No.	Frequency (MHz)	Emission Level (dBuV/m)	Limit (dBuV/m)	Margin (dB)	Raw Value (dBm)	Correction Factor (dB)	EIRP Level (dBm)
1	2437.5 PK	108.97	*		10.83	2.88	13.71
2	2229.68 PK	49.9	74	-24.1	-48.24	2.88	-45.36
3	9096.87 PK	52.15	74	-21.85	-45.99	2.88	-43.11
4	21604.62 PK	53.85	#		-44.29	2.88	-41.41
5	2435.93 AV	105.27	*		7.13	2.88	10.01
6	2350 AV	38.29	54	-15.71	-59.85	2.88	-56.97
7	3089.06 AV	39.81	#		-58.33	2.88	-55.45
8	21657.81 AV	41.95	#		-56.19	2.88	-53.31

Note :

- Emission Level (dBuV/m) = EIRP Level (dBm) – 20log(d) + 104.8  
d = measurement distance in 3 meters.
- \* : Fundamental frequency, the limit was restricted at the output power.
- # : Non-restricted frequency, the limit was restricted at the conducted out of band emission.

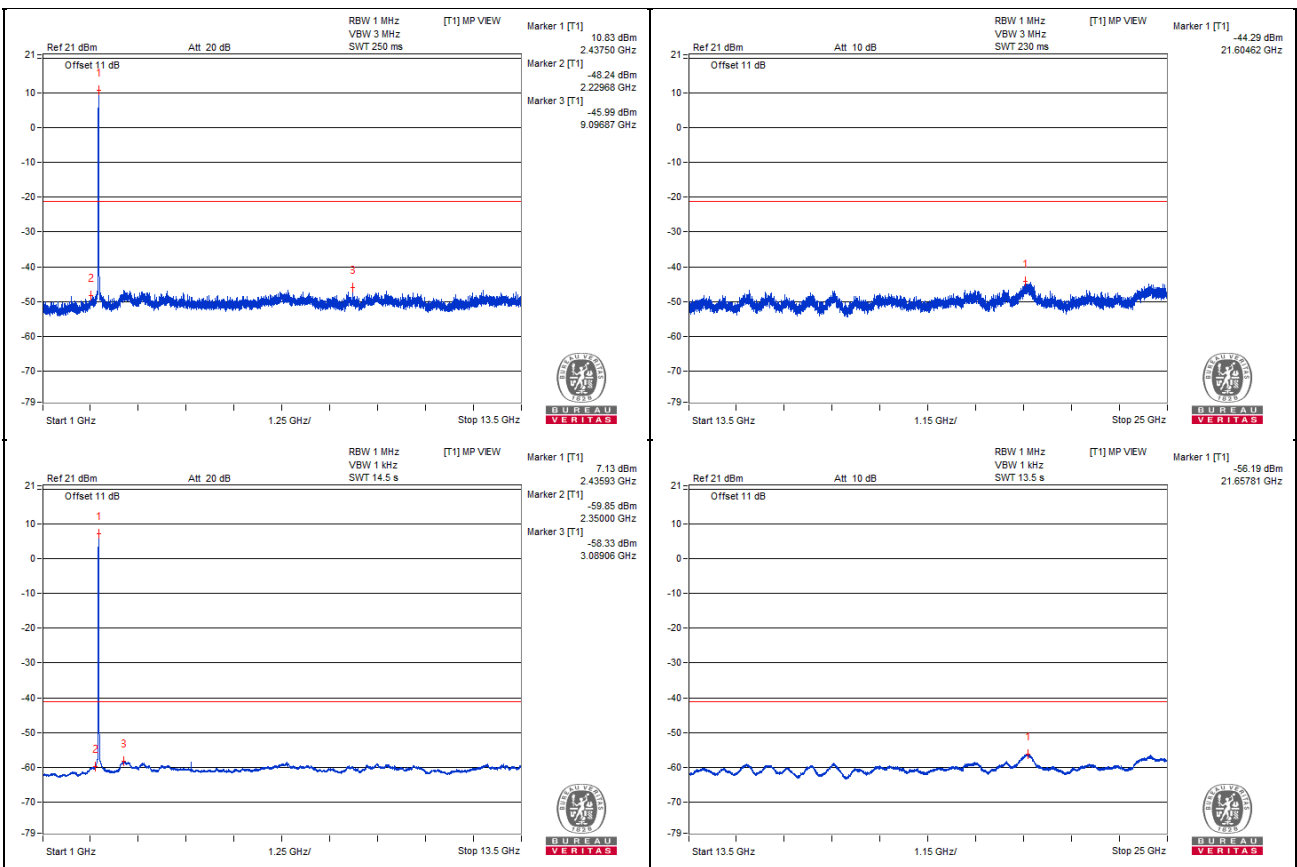

### Bandedge table

No.	Frequency (MHz)	Emission Level (dBuV/m)	Limit (dBuV/m)	Margin (dB)	Raw Value (dBm)	Correction Factor (dB)	EIRP Level (dBm)
1	2437.94 PK	109.12	*		10.98	2.88	13.86
2	2390 PK	50.32	74	-23.68	-47.82	2.88	-44.94
3	2483.5 PK	50.18	74	-23.82	-47.96	2.88	-45.08
4	2386.02 PK	52.28	74	-21.72	-45.86	2.88	-42.98
5	2485.29 PK	52.21	74	-21.79	-45.93	2.88	-43.05
6	2436.23 AV	105.17	*		7.03	2.88	9.91
7	2390 AV	39.05	54	-14.95	-59.09	2.88	-56.21
8	2483.5 AV	39.11	54	-14.89	-59.03	2.88	-56.15
9	2389.94 AV	39.05	54	-14.95	-59.09	2.88	-56.21
10	2483.92 AV	39.29	54	-14.71	-58.85	2.88	-55.97

Note :

1. Emission Level (dBuV/m) = EIRP Level (dBm) – 20log(d) + 104.8  
d = measurement distance in 3 meters.
2. \* : Fundamental frequency, the limit was restricted at the output power.

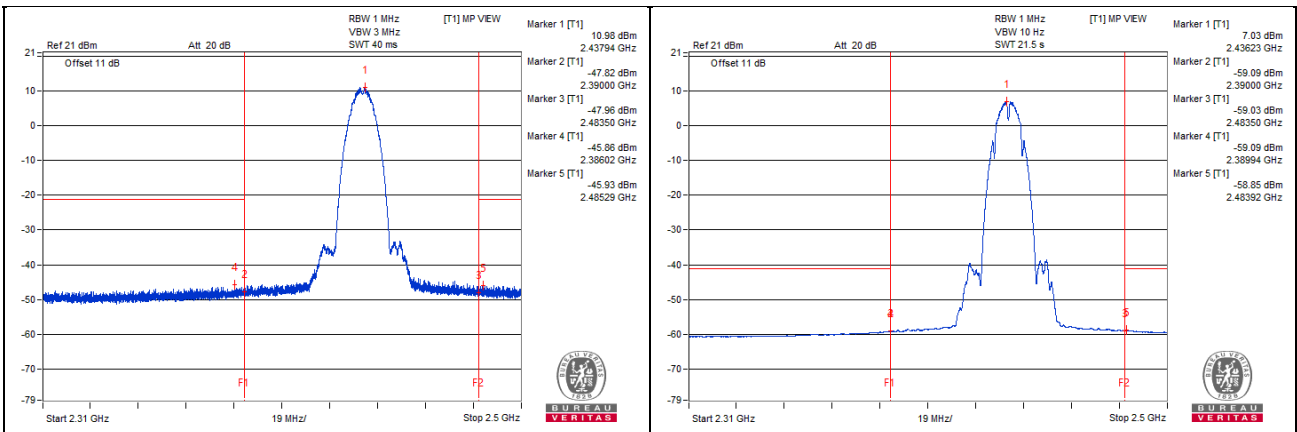

### 802.11b - Channel 11

#### Conducted spurious emission table

No.	Frequency (MHz)	Emission Level (dBuV/m)	Limit (dBuV/m)	Margin (dB)	Raw Value (dBm)	Correction Factor (dB)	EIRP Level (dBm)
1	2462.5 PK	108.91	*		10.77	2.88	13.65
2	2325 PK	50.72	74	-23.28	-47.42	2.88	-44.54
3	7057.81 PK	52.42	#		-45.72	2.88	-42.84
4	21660.68 PK	53.69	#		-44.45	2.88	-41.57
5	2460.93 AV	105.18	*		7.04	2.88	9.92
6	2346.87 AV	37.95	54	-16.05	-60.19	2.88	-57.31
7	4923.43 AV	39.99	54	-14.01	-58.15	2.88	-55.27
8	21617.56 AV	41.9	#		-56.24	2.88	-53.36

Note :

- Emission Level (dBuV/m) = EIRP Level (dBm) – 20log(d) + 104.8  
d = measurement distance in 3 meters.
- \* : Fundamental frequency, the limit was restricted at the output power.
- # : Non-restricted frequency, the limit was restricted at the conducted out of band emission.

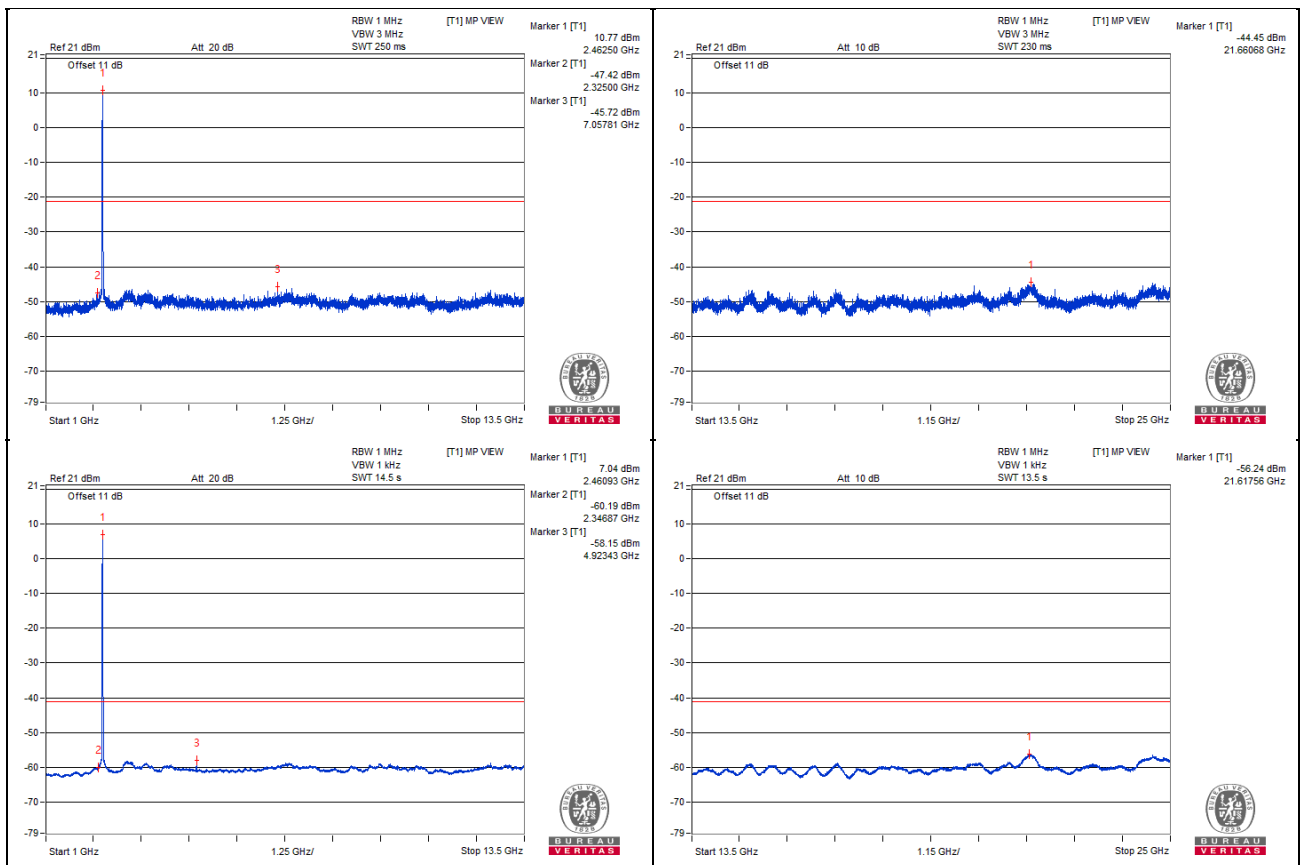

### Bandedge table

No.	Frequency (MHz)	Emission Level (dBuV/m)	Limit (dBuV/m)	Margin (dB)	Raw Value (dBm)	Correction Factor (dB)	EIRP Level (dBm)
1	2462.99 PK	109.05	*		10.91	2.88	13.79
2	2390 PK	49.85	74	-24.15	-48.29	2.88	-45.41
3	2483.5 PK	52.13	74	-21.87	-46.01	2.88	-43.13
4	2386.61 PK	51.65	74	-22.35	-46.49	2.88	-43.61
5	2497.69 PK	53.36	74	-20.64	-44.78	2.88	-41.9
6	2461.24 AV	105.11	*		6.97	2.88	9.85
7	2390 AV	37.96	54	-16.04	-60.18	2.88	-57.3
8	2483.5 AV	40.07	54	-13.93	-58.07	2.88	-55.19
9	2385.88 AV	38.14	54	-15.86	-60	2.88	-57.12
10	2484.01 AV	40.48	54	-13.52	-57.66	2.88	-54.78

Note :

1. Emission Level (dBuV/m) = EIRP Level (dBm) – 20log(d) + 104.8  
d = measurement distance in 3 meters.
2. \* : Fundamental frequency, the limit was restricted at the output power.

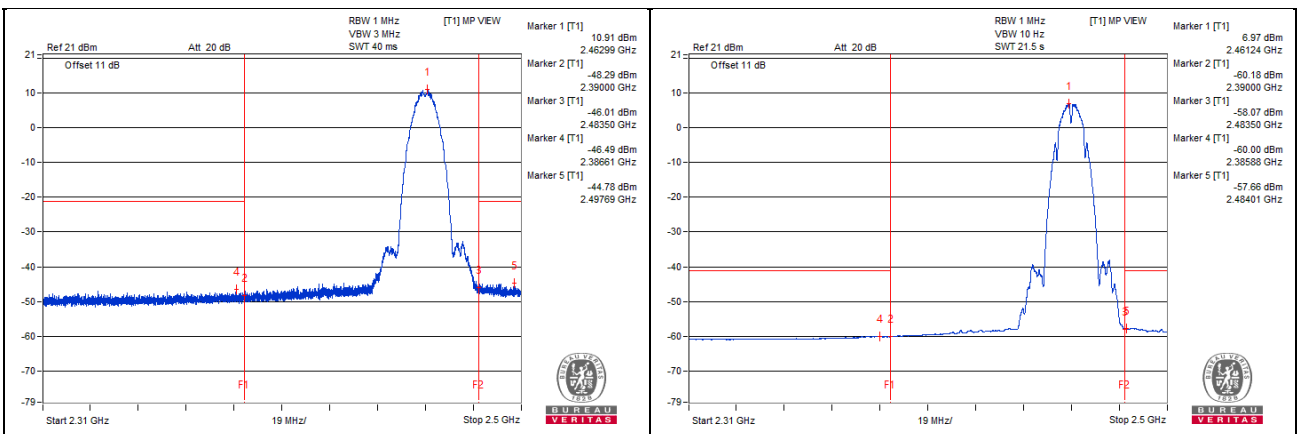



### 802.11g - Channel 1

#### Conducted spurious emission table

No.	Frequency (MHz)	Emission Level (dBuV/m)	Limit (dBuV/m)	Margin (dB)	Raw Value (dBm)	Correction Factor (dB)	EIRP Level (dBm)
1	2410.93 PK	109.47	*		11.33	2.88	14.21
2	2342.18 PK	52.61	74	-21.39	-45.53	2.88	-42.65
3	7248.43 PK	52.59	#		-45.55	2.88	-42.67
4	24646.37 PK	53.54	#		-44.6	2.88	-41.72
5	2410.93 AV	100.64	*		2.5	2.88	5.38
6	2348.43 AV	40.91	54	-13.09	-57.23	2.88	-54.35
7	3104.68 AV	39.94	#		-58.2	2.88	-55.32
8	21627.62 AV	41.96	#		-56.18	2.88	-53.3

Note :

- Emission Level (dBuV/m) = EIRP Level (dBm) – 20log(d) + 104.8  
d = measurement distance in 3 meters.
- \* : Fundamental frequency, the limit was restricted at the output power.
- # : Non-restricted frequency, the limit was restricted at the conducted out of band emission.

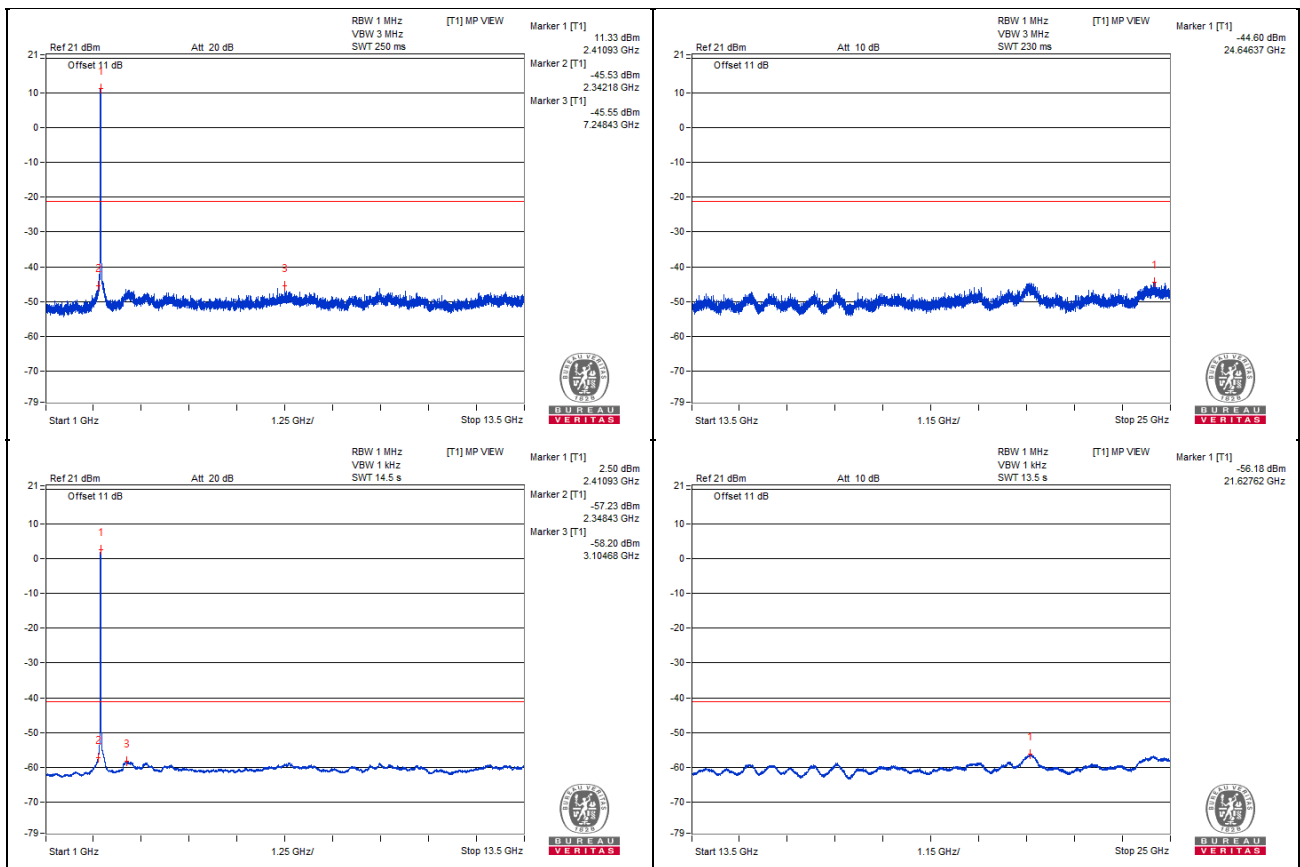

### Bandedge table

No.	Frequency (MHz)	Emission Level (dBUV/m)	Limit (dBUV/m)	Margin (dB)	Raw Value (dBm)	Correction Factor (dB)	EIRP Level (dBm)
1	2413.5 PK	111.25	*		13.11	2.88	15.99
2	2390 PK	60.04	74	-13.96	-38.1	2.88	-35.22
3	2483.5 PK	51.61	74	-22.39	-46.53	2.88	-43.65
4	2389.99 PK	60.04	74	-13.96	-38.1	2.88	-35.22
5	2489.83 PK	54.48	74	-19.52	-43.66	2.88	-40.78
6	2411.03 AV	100.31	*		2.17	2.88	5.05
7	2390 AV	45.67	54	-8.33	-52.47	2.88	-49.59
8	2483.5 AV	40.9	54	-13.1	-57.24	2.88	-54.36
9	2390 AV	45.67	54	-8.33	-52.47	2.88	-49.59
10	2483.99 AV	40.98	54	-13.02	-57.16	2.88	-54.28

#### Note :

- Emission Level (dBUV/m) = EIRP Level (dBm) – 20log(d) + 104.8  
d = measurement distance in 3 meters.
- \* : Fundamental frequency, the limit was restricted at the output power.

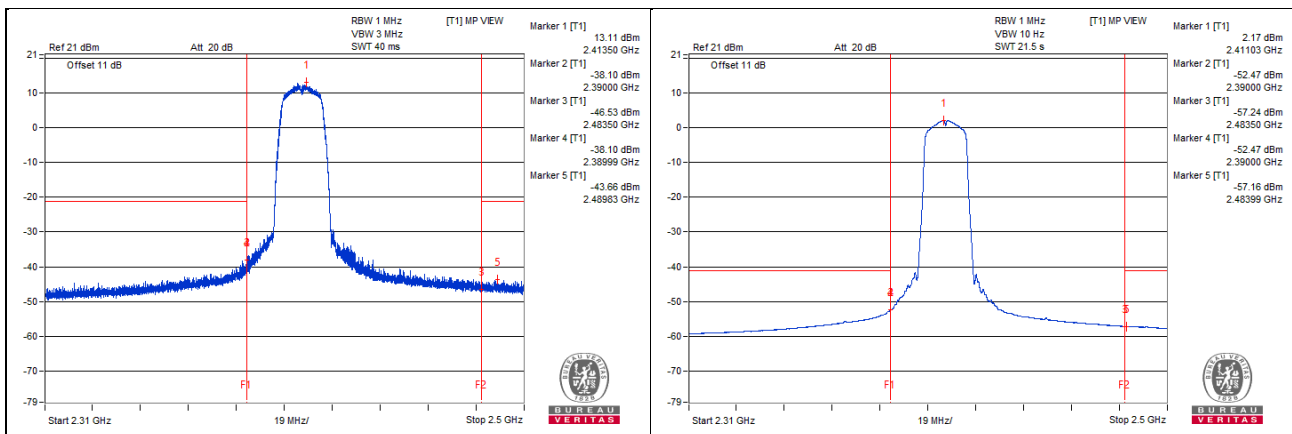

### 802.11g - Channel 6

#### Conducted spurious emission table

No.	Frequency (MHz)	Emission Level (dBuV/m)	Limit (dBuV/m)	Margin (dB)	Raw Value (dBm)	Correction Factor (dB)	EIRP Level (dBm)
1	2437.5 PK	111.36	*		13.22	2.88	16.1
2	2346.87 PK	51.17	74	-22.83	-46.97	2.88	-44.09
3	3120.31 PK	51.8	#		-46.34	2.88	-43.46
4	21709.56 PK	54.55	#		-43.59	2.88	-40.71
5	2435.93 AV	101.02	*		2.88	2.88	5.76
6	2348.43 AV	40.12	54	-13.88	-58.02	2.88	-55.14
7	2533.5 AV	39.82	#		-58.32	2.88	-55.44
8	21649.18 AV	41.81	#		-56.33	2.88	-53.45

Note :

- Emission Level (dBuV/m) = EIRP Level (dBm) – 20log(d) + 104.8  
d = measurement distance in 3 meters.
- \* : Fundamental frequency, the limit was restricted at the output power.
- # : Non-restricted frequency, the limit was restricted at the conducted out of band emission.

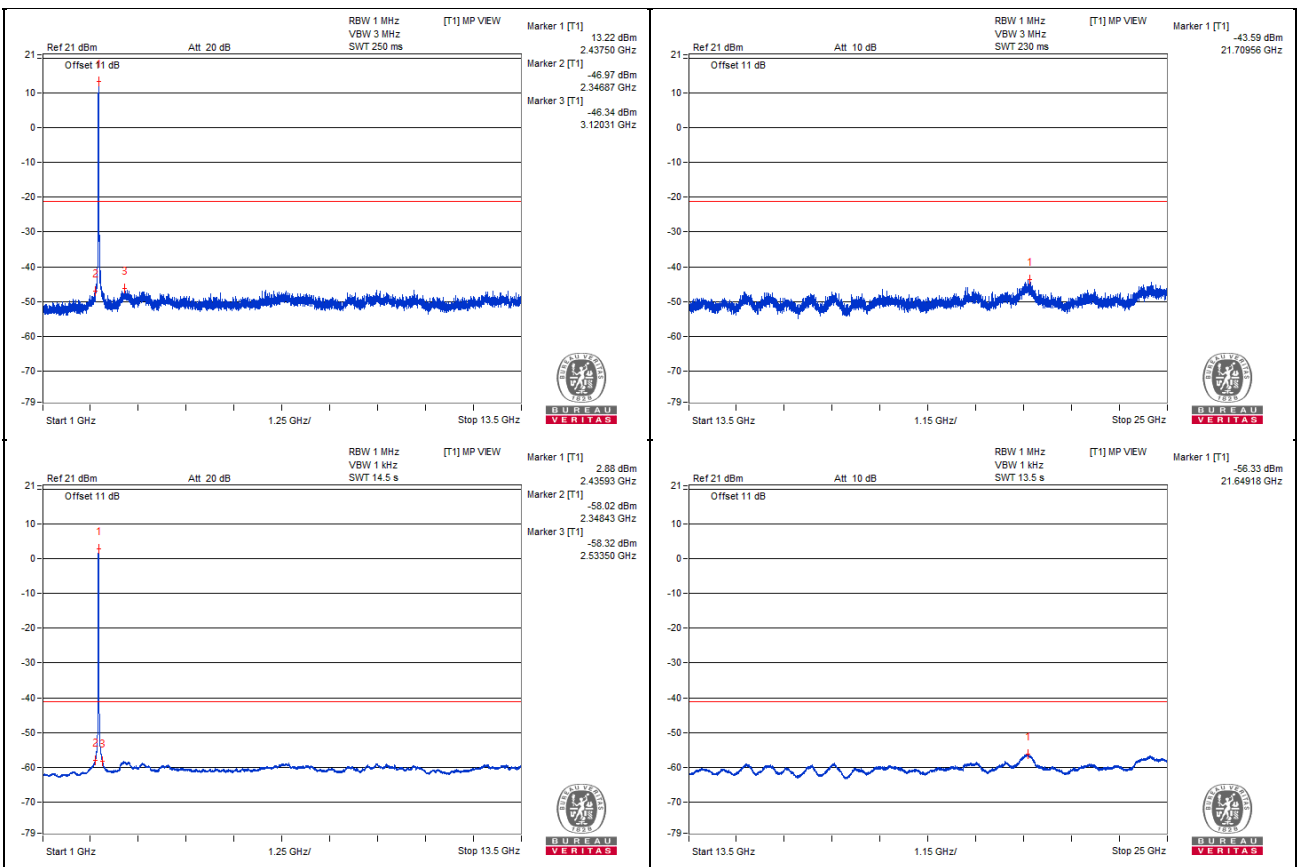

### Bandedge table

No.	Frequency (MHz)	Emission Level (dBuV/m)	Limit (dBuV/m)	Margin (dB)	Raw Value (dBm)	Correction Factor (dB)	EIRP Level (dBm)
1	2437.84 PK	111.56	*		13.42	2.88	16.3
2	2390 PK	55.13	74	-18.87	-43.01	2.88	-40.13
3	2483.5 PK	55.04	74	-18.96	-43.1	2.88	-40.22
4	2389.65 PK	55.77	74	-18.23	-42.37	2.88	-39.49
5	2484.13 PK	56.2	74	-17.8	-41.94	2.88	-39.06
6	2435.92 AV	100.48	*		2.34	2.88	5.22
7	2390 AV	42.42	54	-11.58	-55.72	2.88	-52.84
8	2483.5 AV	42.69	54	-11.31	-55.45	2.88	-52.57
9	2389.77 AV	42.45	54	-11.55	-55.69	2.88	-52.81
10	2483.82 AV	42.76	54	-11.24	-55.38	2.88	-52.5

Note :

- Emission Level (dBuV/m) = EIRP Level (dBm) – 20log(d) + 104.8  
d = measurement distance in 3 meters.
- \* : Fundamental frequency, the limit was restricted at the output power.

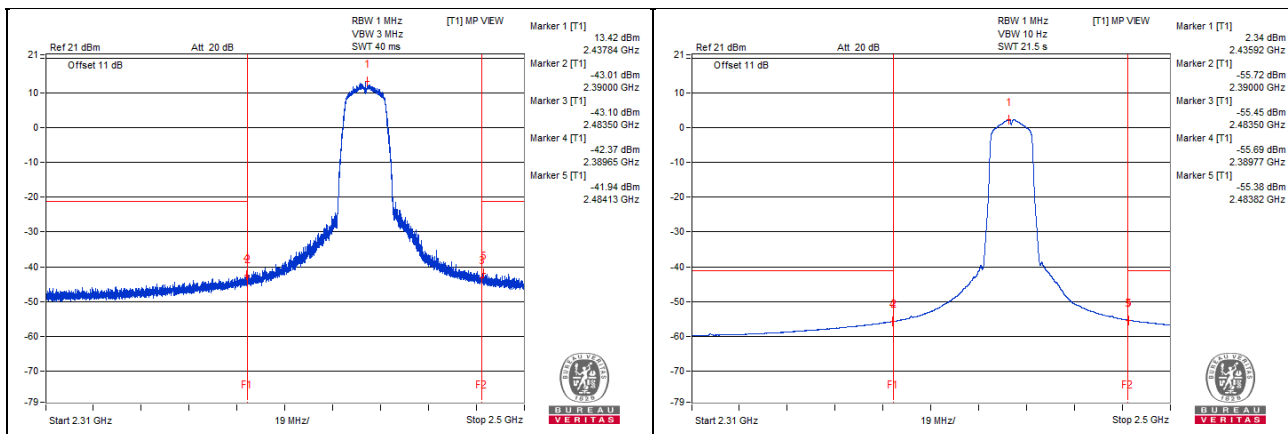

### 802.11g - Channel 11

#### Conducted spurious emission table

No.	Frequency (MHz)	Emission Level (dBUV/m)	Limit (dBUV/m)	Margin (dB)	Raw Value (dBm)	Correction Factor (dB)	EIRP Level (dBm)
1	2460.93 PK	109.49	*		11.35	2.88	14.23
2	2331.25 PK	49.87	74	-24.13	-48.27	2.88	-45.39
3	2567.18 PK	52.48	#		-45.66	2.88	-42.78
4	21604.62 PK	54.88	#		-43.26	2.88	-40.38
5	2460.93 AV	101.21	*		3.07	2.88	5.95
6	2350 AV	39.28	54	-14.72	-58.86	2.88	-55.98
7	2533.5 AV	41.08	#		-57.06	2.88	-54.18
8	21643.43 AV	42.03	#		-56.11	2.88	-53.23

Note :

- Emission Level (dBUV/m) = EIRP Level (dBm) – 20log(d) + 104.8  
d = measurement distance in 3 meters.
- \* : Fundamental frequency, the limit was restricted at the output power.
- # : Non-restricted frequency, the limit was restricted at the conducted out of band emission.

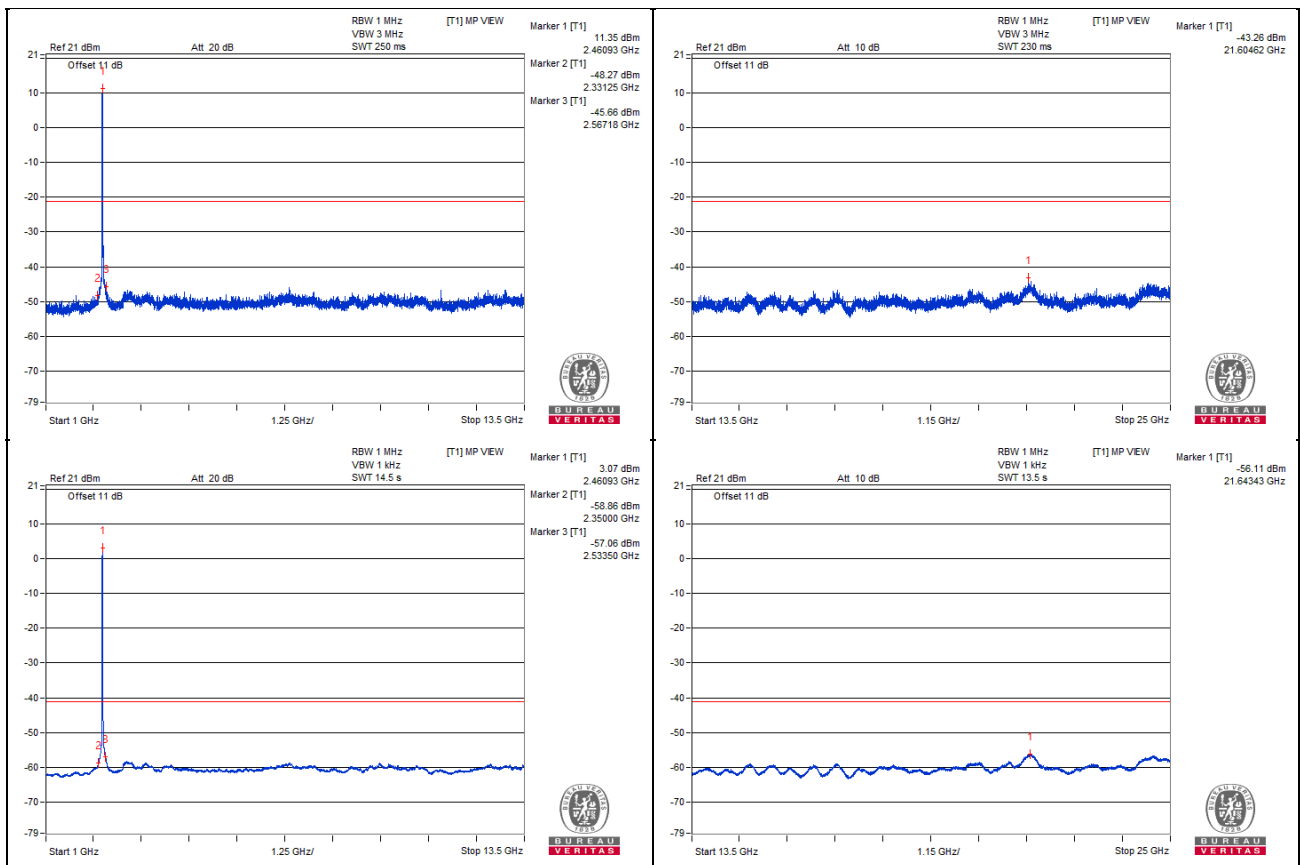

### Bandedge table

No.	Frequency (MHz)	Emission Level (dBuV/m)	Limit (dBuV/m)	Margin (dB)	Raw Value (dBm)	Correction Factor (dB)	EIRP Level (dBm)
1	2462.85 PK	111.55	*		13.41	2.88	16.29
2	2390 PK	51.55	74	-22.45	-46.59	2.88	-43.71
3	2483.5 PK	58.14	74	-15.86	-40	2.88	-37.12
4	2386.76 PK	53.64	74	-20.36	-44.5	2.88	-41.62
5	2484.18 PK	61.92	74	-12.08	-36.22	2.88	-33.34
6	2461.05 AV	100.58	*		2.44	2.88	5.32
7	2390 AV	40.26	54	-13.74	-57.88	2.88	-55
8	2483.5 AV	45.92	54	-8.08	-52.22	2.88	-49.34
9	2389.89 AV	40.27	54	-13.73	-57.87	2.88	-54.99
10	2483.77 AV	45.95	54	-8.05	-52.19	2.88	-49.31

Note :

- Emission Level (dBuV/m) = EIRP Level (dBm) – 20log(d) + 104.8  
d = measurement distance in 3 meters.
- \* : Fundamental frequency, the limit was restricted at the output power.

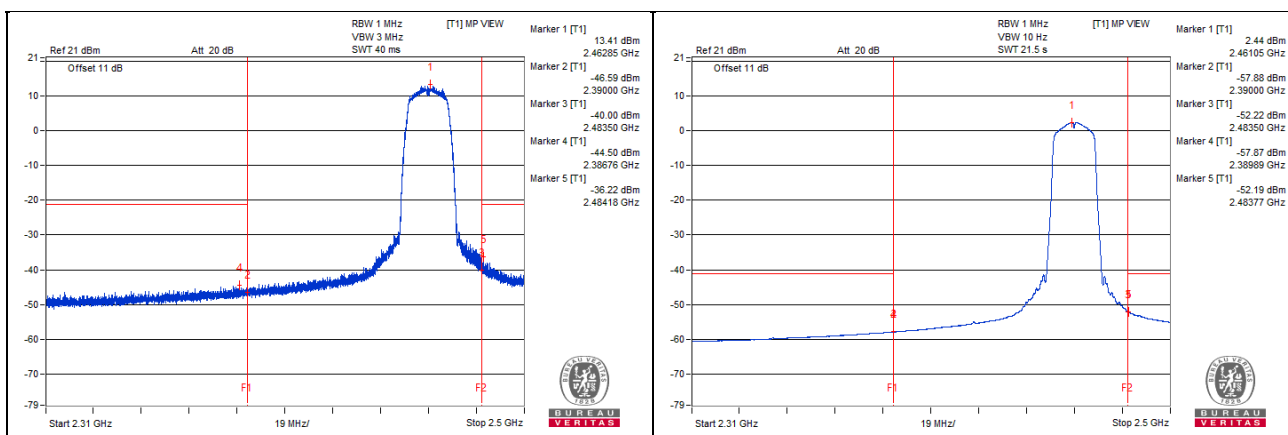

### 802.11n (HT20) - Channel 1

#### Conducted spurious emission table

No.	Frequency (MHz)	Emission Level (dBUV/m)	Limit (dBUV/m)	Margin (dB)	Raw Value (dBm)	Correction Factor (dB)	EIRP Level (dBm)
1	2412.5 PK	108.86	*		10.72	2.88	13.6
2	2350 PK	51.29	74	-22.71	-46.85	2.88	-43.97
3	13356.25 PK	51.71	74	-22.29	-46.43	2.88	-43.55
4	24616.18 PK	53.86	#		-44.28	2.88	-41.4
5	2409.37 AV	99.74	*		1.6	2.88	4.48
6	2350 AV	39.81	54	-14.19	-58.33	2.88	-55.45
7	3229.68 AV	39.69	#		-58.45	2.88	-55.57
8	21643.43 AV	41.99	#		-56.15	2.88	-53.27

Note :

- Emission Level (dBUV/m) = EIRP Level (dBm) – 20log(d) + 104.8  
d = measurement distance in 3 meters.
- \* : Fundamental frequency, the limit was restricted at the output power.
- # : Non-restricted frequency, the limit was restricted at the conducted out of band emission.

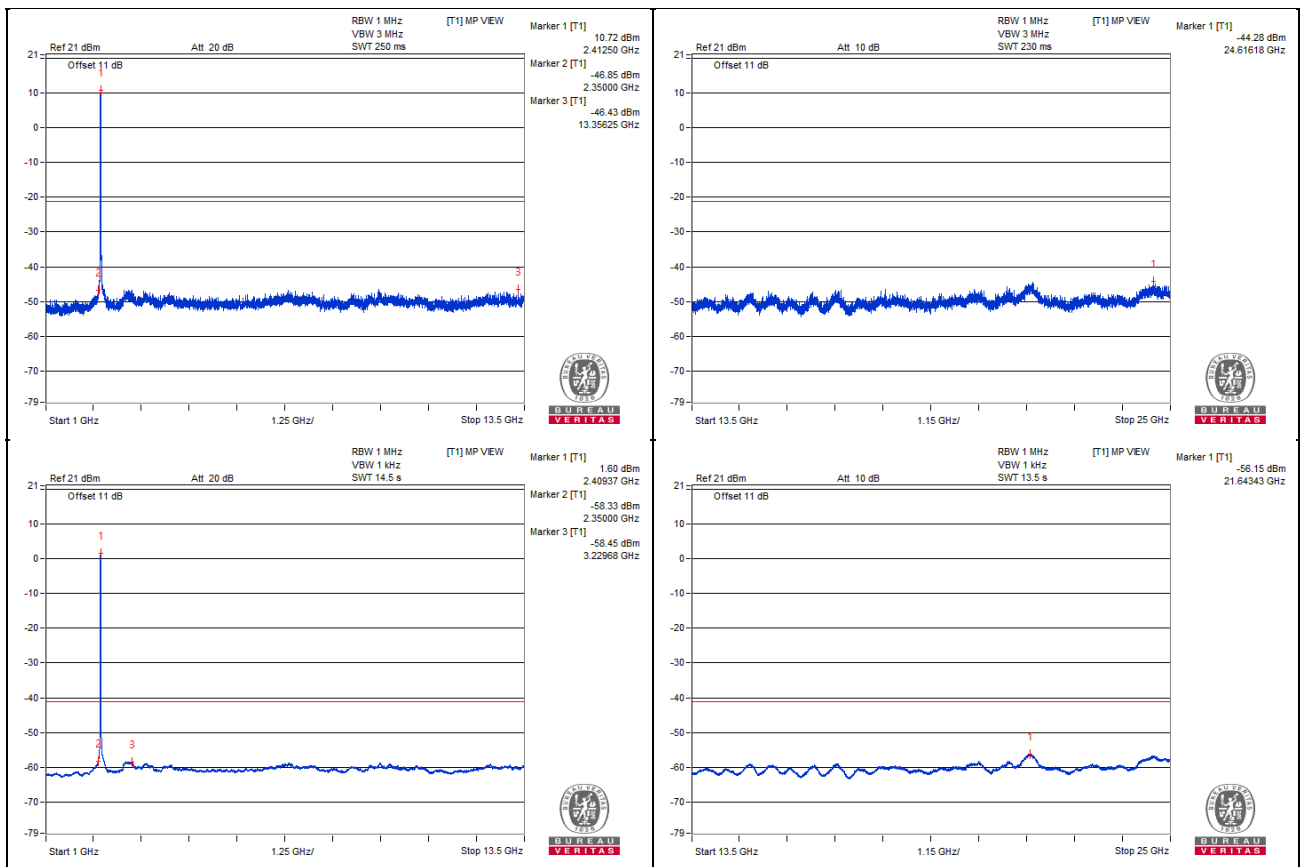

### Bandedge table

No.	Frequency (MHz)	Emission Level (dBuV/m)	Limit (dBuV/m)	Margin (dB)	Raw Value (dBm)	Correction Factor (dB)	EIRP Level (dBm)
1	2413.43 PK	109.74	*		11.6	2.88	14.48
2	2390 PK	58.74	74	-15.26	-39.4	2.88	-36.52
3	2483.5 PK	51.16	74	-22.84	-46.98	2.88	-44.1
4	2389.7 PK	60.09	74	-13.91	-38.05	2.88	-35.17
5	2493.08 PK	53.96	74	-20.04	-44.18	2.88	-41.3
6	2412.88 AV	99.21	*		1.07	2.88	3.95
7	2390 AV	45.27	54	-8.73	-52.87	2.88	-49.99
8	2483.5 AV	39.81	54	-14.19	-58.33	2.88	-55.45
9	2390 AV	45.28	54	-8.72	-52.86	2.88	-49.98
10	2483.77 AV	39.84	54	-14.16	-58.3	2.88	-55.42

**Note :**

- Emission Level (dBuV/m) = EIRP Level (dBm) – 20log(d) + 104.8  
d = measurement distance in 3 meters.
- \* : Fundamental frequency, the limit was restricted at the output power.

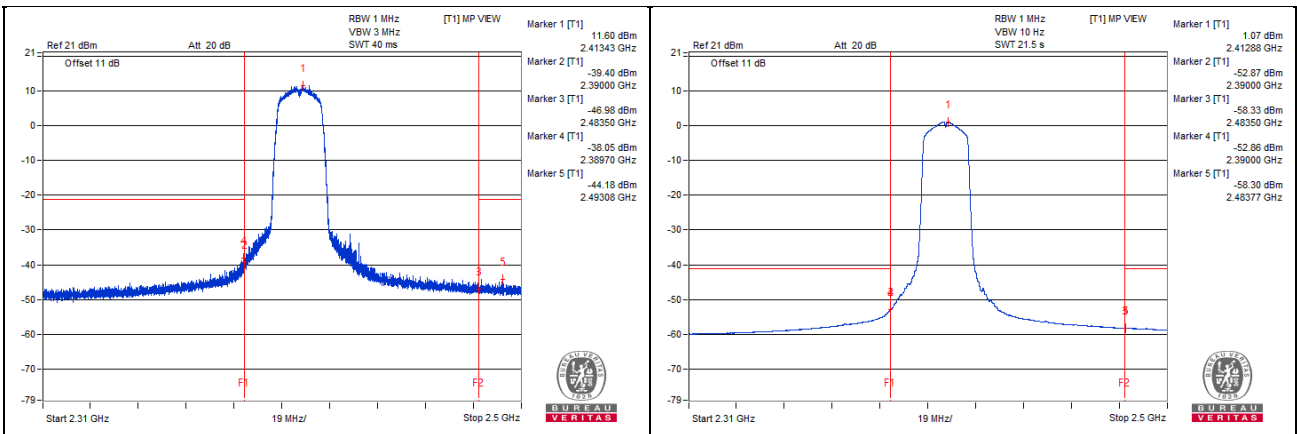



### 802.11n (HT20) - Channel 6

#### Conducted spurious emission table

No.	Frequency (MHz)	Emission Level (dBUV/m)	Limit (dBUV/m)	Margin (dB)	Raw Value (dBm)	Correction Factor (dB)	EIRP Level (dBm)
1	2432.81 PK	109.17	*		11.03	2.88	13.91
2	2348.43 PK	51.3	74	-22.7	-46.84	2.88	-43.96
3	3095.31 PK	52.53	#		-45.61	2.88	-42.73
4	24620.5 PK	53.86	#		-44.28	2.88	-41.4
5	2435.93 AV	99.84	*		1.7	2.88	4.58
6	2350 AV	40.17	54	-13.83	-57.97	2.88	-55.09
7	2533.5 AV	39.91	#		-58.23	2.88	-55.35
8	21596 AV	41.97	#		-56.17	2.88	-53.29

Note :

- Emission Level (dBUV/m) = EIRP Level (dBm) – 20log(d) + 104.8  
d = measurement distance in 3 meters.
- \* : Fundamental frequency, the limit was restricted at the output power.
- # : Non-restricted frequency, the limit was restricted at the conducted out of band emission.

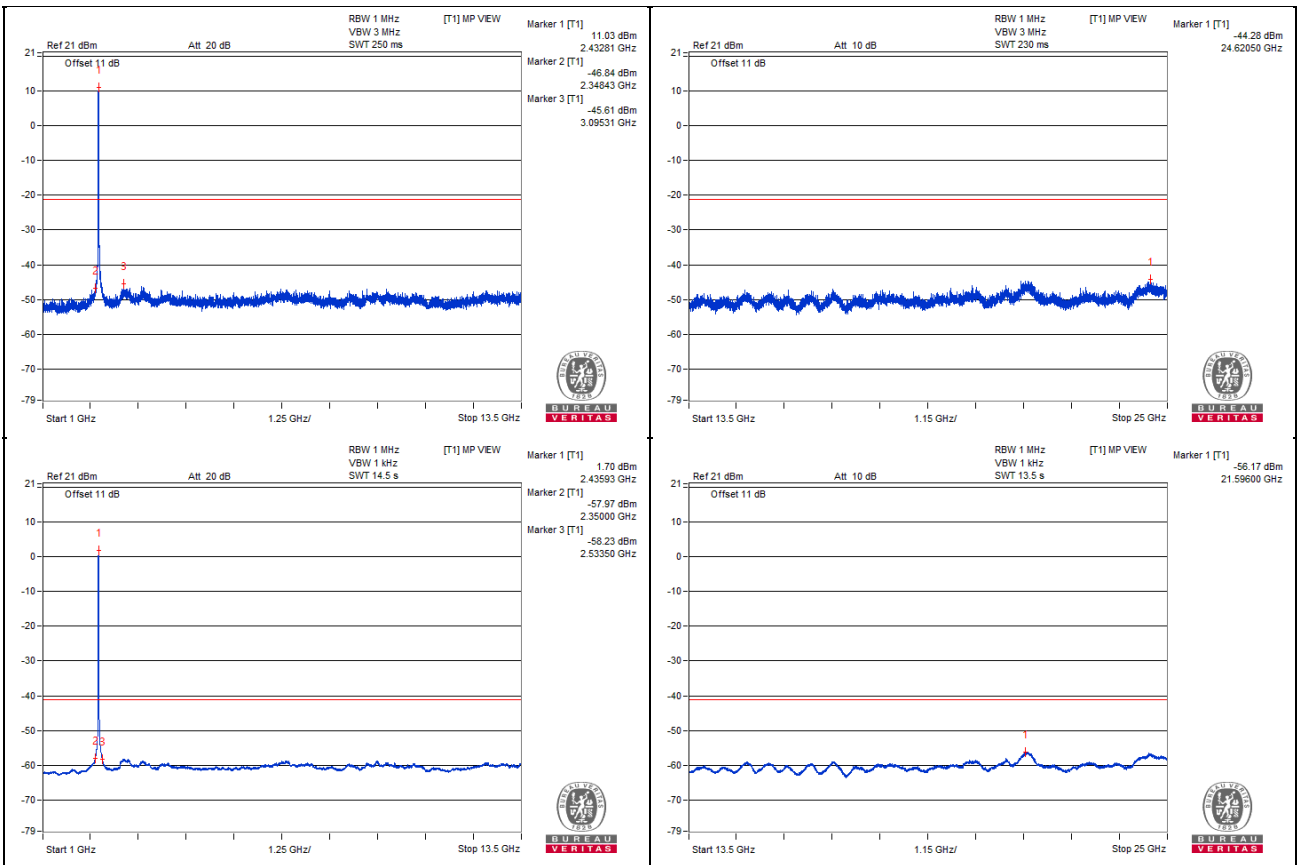

### Bandedge table

No.	Frequency (MHz)	Emission Level (dBuV/m)	Limit (dBuV/m)	Margin (dB)	Raw Value (dBm)	Correction Factor (dB)	EIRP Level (dBm)
1	2438.72 PK	109.8	*		11.66	2.88	14.54
2	2390 PK	53.57	74	-20.43	-44.57	2.88	-41.69
3	2483.5 PK	53.69	74	-20.31	-44.45	2.88	-41.57
4	2389.94 PK	55.93	74	-18.07	-42.21	2.88	-39.33
5	2488.33 PK	55.58	74	-18.42	-42.56	2.88	-39.68
6	2436.01 AV	99.35	*		1.21	2.88	4.09
7	2390 AV	42.4	54	-11.6	-55.74	2.88	-52.86
8	2483.5 AV	42.73	54	-11.27	-55.41	2.88	-52.53
9	2389.77 AV	42.42	54	-11.58	-55.72	2.88	-52.84
10	2483.56 AV	42.73	54	-11.27	-55.41	2.88	-52.53

Note :

- Emission Level (dBuV/m) = EIRP Level (dBm) – 20log(d) + 104.8  
d = measurement distance in 3 meters.
- \* : Fundamental frequency, the limit was restricted at the output power.

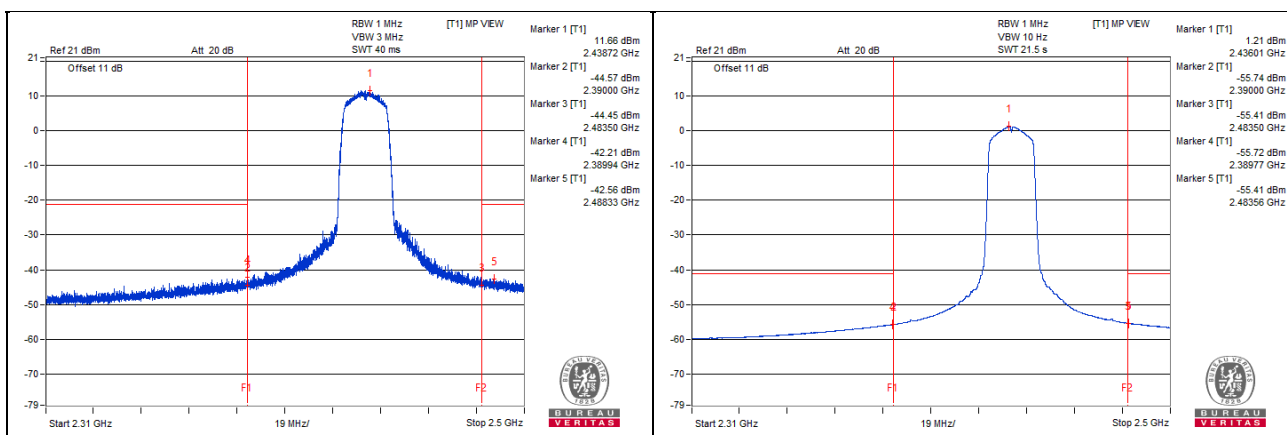

**802.11n (HT20) - Channel 11**  
**Conducted spurious emission table**

No.	Frequency (MHz)	Emission Level (dBUV/m)	Limit (dBUV/m)	Margin (dB)	Raw Value (dBm)	Correction Factor (dB)	EIRP Level (dBm)
1	2459.37 PK	108.56	*		10.42	2.88	13.3
2	2335.93 PK	49.65	74	-24.35	-48.49	2.88	-45.61
3	9739.06 PK	51.53	#		-46.61	2.88	-43.73
4	24617.62 PK	53.94	#		-44.2	2.88	-41.32
5	2459.37 AV	99.79	*		1.65	2.88	4.53
6	2350 AV	38.73	54	-15.27	-59.41	2.88	-56.53
7	2533.5 AV	40.02	#		-58.12	2.88	-55.24
8	21657.81 AV	41.85	#		-56.29	2.88	-53.41

Note :

- Emission Level (dBUV/m) = EIRP Level (dBm) – 20log(d) + 104.8  
d = measurement distance in 3 meters.
- \* : Fundamental frequency, the limit was restricted at the output power.
- # : Non-restricted frequency, the limit was restricted at the conducted out of band emission.

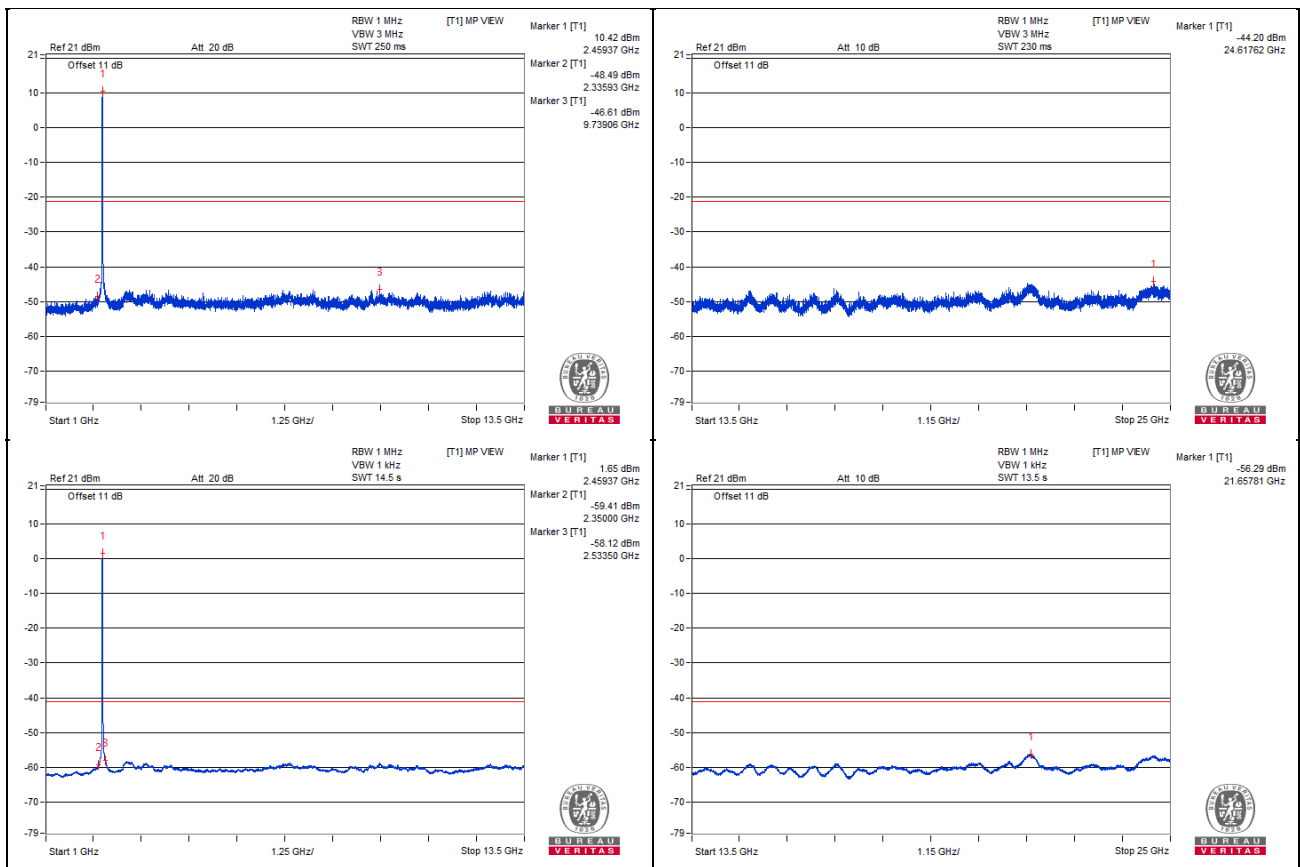

### Bandedge table

No.	Frequency (MHz)	Emission Level (dBuV/m)	Limit (dBuV/m)	Margin (dB)	Raw Value (dBm)	Correction Factor (dB)	EIRP Level (dBm)
1	2460.48 PK	109.92	*		11.78	2.88	14.66
2	2390 PK	50.23	74	-23.77	-47.91	2.88	-45.03
3	2483.5 PK	61.17	74	-12.83	-36.97	2.88	-34.09
4	2382.01 PK	52.86	74	-21.14	-45.28	2.88	-42.4
5	2483.5 PK	60.43	74	-13.57	-37.71	2.88	-34.83
6	2462.9 AV	99.41	*		1.27	2.88	4.15
7	2390 AV	39.2	54	-14.8	-58.94	2.88	-56.06
8	2483.5 AV	44.42	54	-9.58	-53.72	2.88	-50.84
9	2389.99 AV	39.2	54	-14.8	-58.94	2.88	-56.06
10	2483.87 AV	44.52	54	-9.48	-53.62	2.88	-50.74

#### Note :

- Emission Level (dBuV/m) = EIRP Level (dBm) – 20log(d) + 104.8  
d = measurement distance in 3 meters.
- \* : Fundamental frequency, the limit was restricted at the output power.

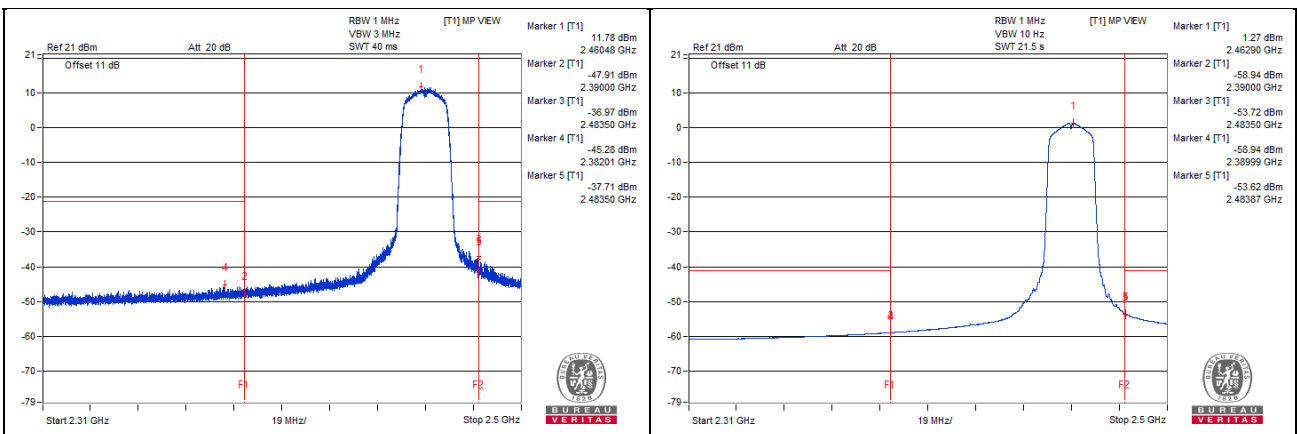

**802.11n (HT40) - Channel 3**  
**Conducted spurious emission table**

No.	Frequency (MHz)	Emission Level (dBuV/m)	Limit (dBuV/m)	Margin (dB)	Raw Value (dBm)	Correction Factor (dB)	EIRP Level (dBm)
1	2417.18 PK	106.43	*		8.29	2.88	11.17
2	2348.43 PK	51.22	74	-22.78	-46.92	2.88	-44.04
3	13495.31 PK	52.01	#		-46.13	2.88	-43.25
4	24698.12 PK	53.88	#		-44.26	2.88	-41.38
5	2423.43 AV	97.16	*		-0.98	2.88	1.9
6	2350 AV	39.8	54	-14.2	-58.34	2.88	-55.46
7	3084.37 AV	39.76	#		-58.38	2.88	-55.5
8	21630.5 AV	42.07	#		-56.07	2.88	-53.19

Note :

- Emission Level (dBuV/m) = EIRP Level (dBm) – 20log(d) + 104.8  
d = measurement distance in 3 meters.
- \* : Fundamental frequency, the limit was restricted at the output power.
- # : Non-restricted frequency, the limit was restricted at the conducted out of band emission.

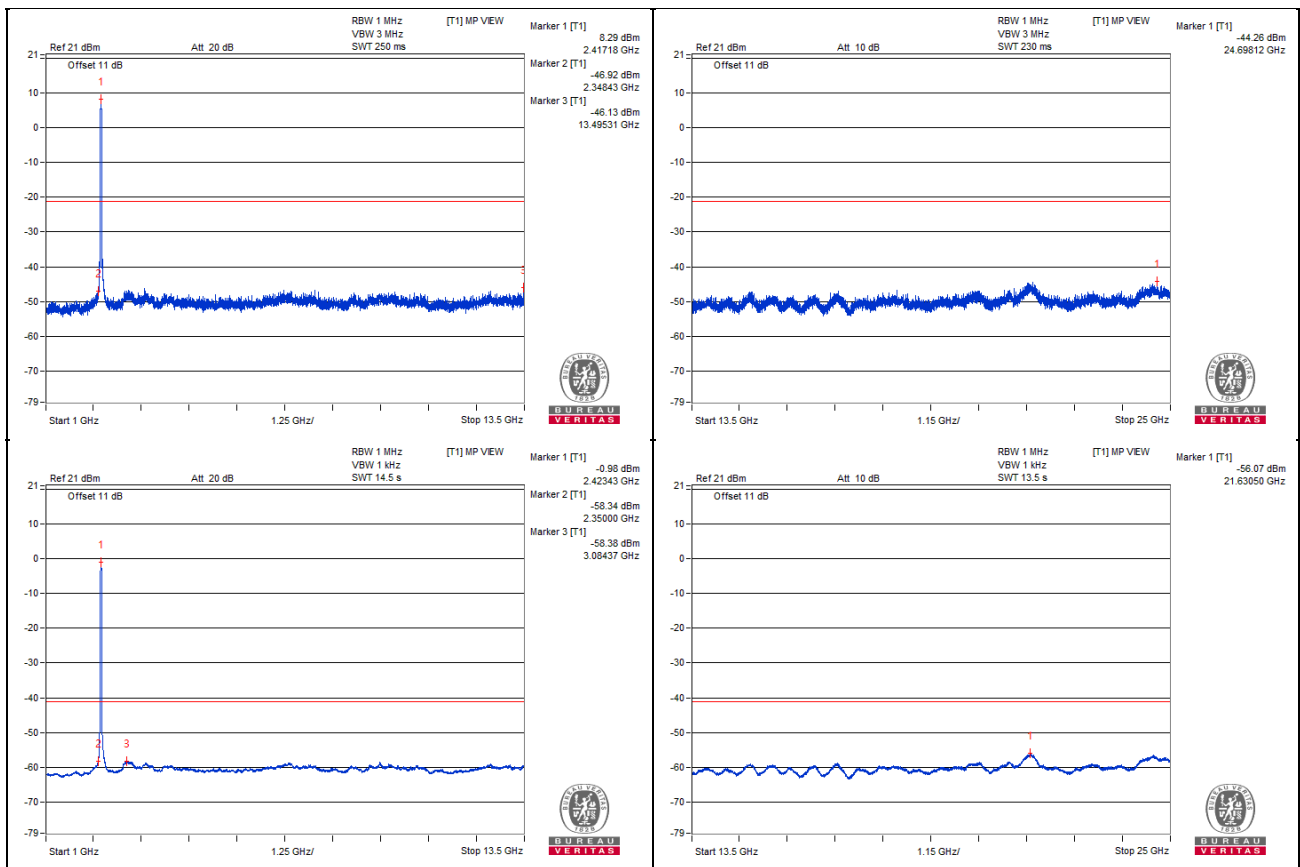

### Bandedge table

No.	Frequency (MHz)	Emission Level (dBuV/m)	Limit (dBuV/m)	Margin (dB)	Raw Value (dBm)	Correction Factor (dB)	EIRP Level (dBm)
1	2417.01 PK	107.61	*		9.47	2.88	12.35
2	2390 PK	61.09	74	-12.91	-37.05	2.88	-34.17
3	2483.5 PK	53.4	74	-20.6	-44.74	2.88	-41.86
4	2389.75 PK	64.04	74	-9.96	-34.1	2.88	-31.22
5	2485.72 PK	57.89	74	-16.11	-40.25	2.88	-37.37
6	2420.39 AV	96.75	*		-1.39	2.88	1.49
7	2390 AV	49.77	54	-4.23	-48.37	2.88	-45.49
8	2483.5 AV	41.83	54	-12.17	-56.31	2.88	-53.43
9	2389.94 AV	49.79	54	-4.21	-48.35	2.88	-45.47
10	2483.5 AV	41.83	54	-12.17	-56.31	2.88	-53.43

Note :

- Emission Level (dBuV/m) = EIRP Level (dBm) – 20log(d) + 104.8  
d = measurement distance in 3 meters.
- \* : Fundamental frequency, the limit was restricted at the output power.

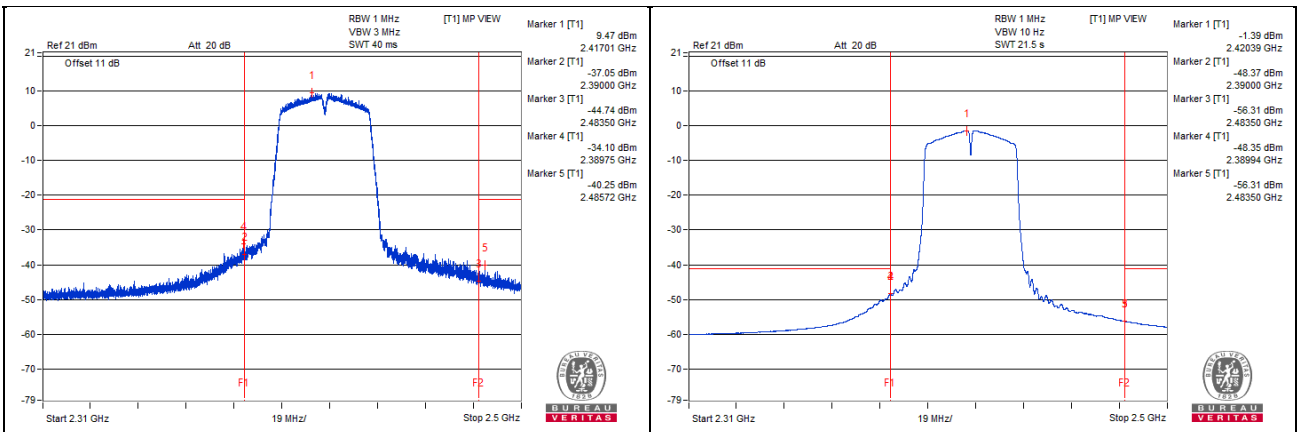

### 802.11n (HT40) - Channel 6

#### Conducted spurious emission table

No.	Frequency (MHz)	Emission Level (dBUV/m)	Limit (dBUV/m)	Margin (dB)	Raw Value (dBm)	Correction Factor (dB)	EIRP Level (dBm)
1	2437.5 PK	105.63	*		7.49	2.88	10.37
2	2346.87 PK	51.66	74	-22.34	-46.48	2.88	-43.6
3	3167.18 PK	51.89	#		-46.25	2.88	-43.37
4	21642 PK	53.78	#		-44.36	2.88	-41.48
5	2434.37 AV	97.51	*		-0.63	2.88	2.25
6	2348.43 AV	40.21	54	-13.79	-57.93	2.88	-55.05
7	2540.62 AV	40.16	#		-57.98	2.88	-55.1
8	21660.68 AV	41.97	#		-56.17	2.88	-53.29

Note :

- Emission Level (dBUV/m) = EIRP Level (dBm) – 20log(d) + 104.8  
d = measurement distance in 3 meters.
- \* : Fundamental frequency, the limit was restricted at the output power.
- # : Non-restricted frequency, the limit was restricted at the conducted out of band emission.

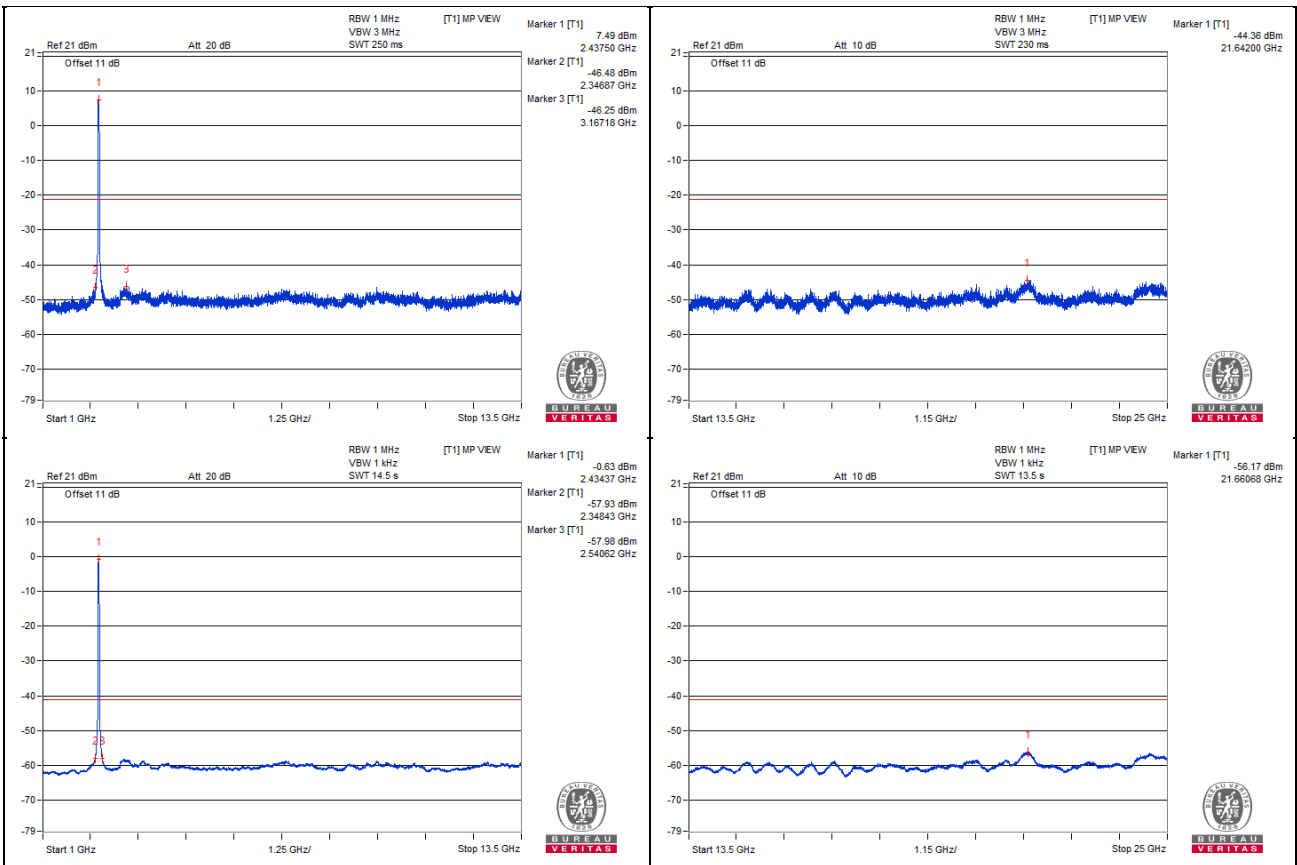

### Bandedge table

No.	Frequency (MHz)	Emission Level (dBuV/m)	Limit (dBuV/m)	Margin (dB)	Raw Value (dBm)	Correction Factor (dB)	EIRP Level (dBm)
1	2443.23 PK	107.51	*		9.37	2.88	12.25
2	2390 PK	59.38	74	-14.62	-38.76	2.88	-35.88
3	2483.5 PK	56.57	74	-17.43	-41.57	2.88	-38.69
4	2389.99 PK	59.38	74	-14.62	-38.76	2.88	-35.88
5	2483.61 PK	59.47	74	-14.53	-38.67	2.88	-35.79
6	2435.56 AV	96.73	*		-1.41	2.88	1.47
7	2390 AV	44.67	54	-9.33	-53.47	2.88	-50.59
8	2483.5 AV	45.18	54	-8.82	-52.96	2.88	-50.08
9	2389.77 AV	44.69	54	-9.31	-53.45	2.88	-50.57
10	2483.5 AV	45.18	54	-8.82	-52.96	2.88	-50.08

Note :

- Emission Level (dBuV/m) = EIRP Level (dBm) – 20log(d) + 104.8  
d = measurement distance in 3 meters.
- \* : Fundamental frequency, the limit was restricted at the output power.

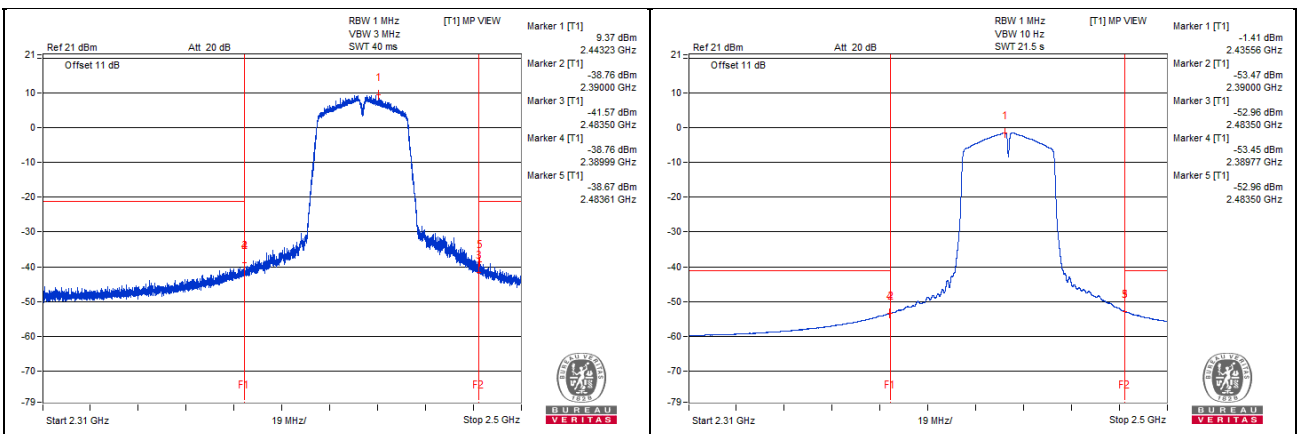



### 802.11n (HT40) - Channel 9

#### Conducted spurious emission table

No.	Frequency (MHz)	Emission Level (dBUV/m)	Limit (dBUV/m)	Margin (dB)	Raw Value (dBm)	Correction Factor (dB)	EIRP Level (dBm)
1	2453.12 PK	105.81	*		7.67	2.88	10.55
2	2350 PK	50.51	74	-23.49	-47.63	2.88	-44.75
3	7060.93 PK	52.31	#		-45.83	2.88	-42.95
4	21624.75 PK	54.35	#		-43.79	2.88	-40.91
5	2450 AV	97.03	*		-1.11	2.88	1.77
6	2348.43 AV	38.57	54	-15.43	-59.57	2.88	-56.69
7	2533.5 AV	39.92	#		-58.22	2.88	-55.34
8	21630.5 AV	41.93	#		-56.21	2.88	-53.33

Note :

- Emission Level (dBUV/m) = EIRP Level (dBm) – 20log(d) + 104.8  
d = measurement distance in 3 meters.
- \* : Fundamental frequency, the limit was restricted at the output power.
- # : Non-restricted frequency, the limit was restricted at the conducted out of band emission.

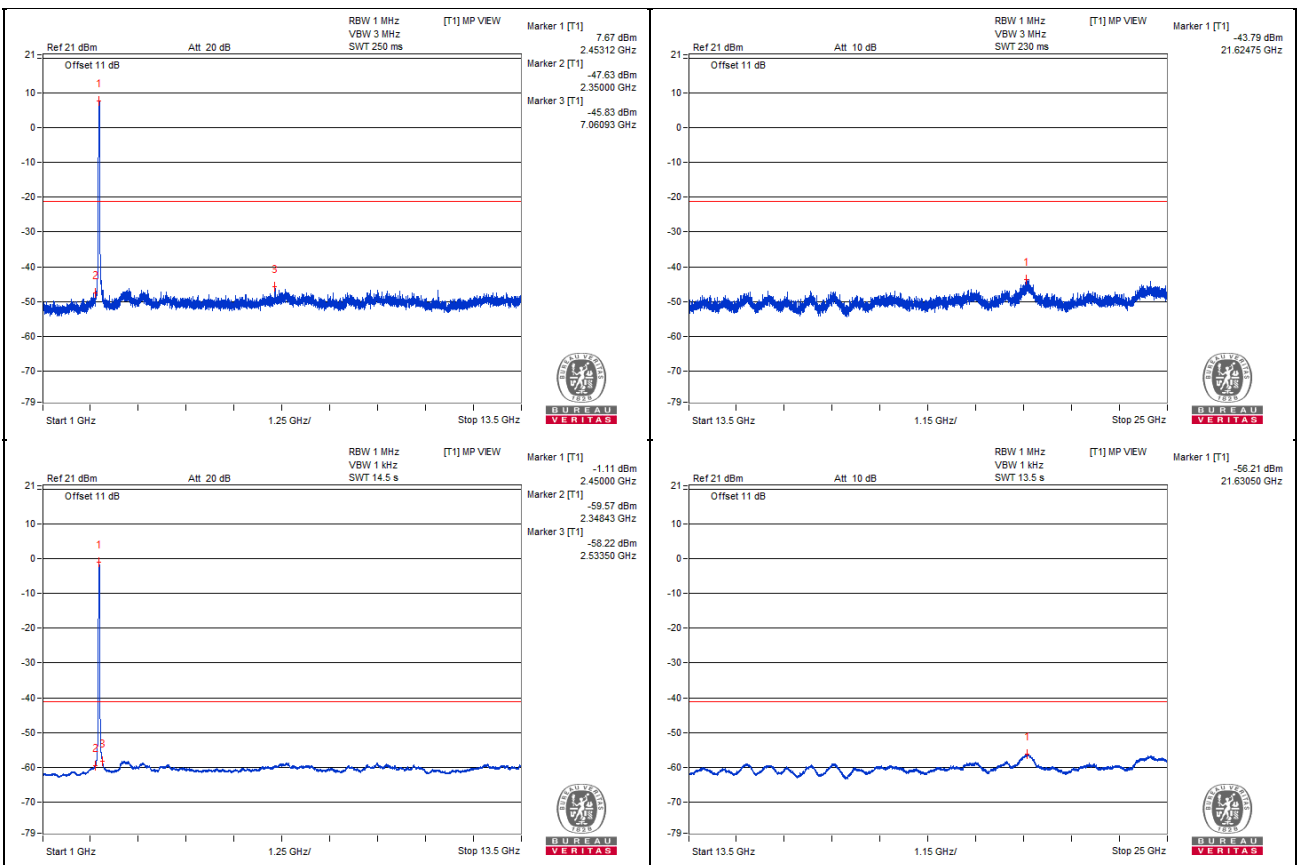

### Bandedge table

No.	Frequency (MHz)	Emission Level (dBuV/m)	Limit (dBuV/m)	Margin (dB)	Raw Value (dBm)	Correction Factor (dB)	EIRP Level (dBm)
1	2453.97 PK	107.47	*		9.33	2.88	12.21
2	2390 PK	50.11	74	-23.89	-48.03	2.88	-45.15
3	2483.5 PK	57.04	74	-16.96	-41.1	2.88	-38.22
4	2388.73 PK	53.33	74	-20.67	-44.81	2.88	-41.93
5	2483.54 PK	60.93	74	-13.07	-37.21	2.88	-34.33
6	2450.36 AV	96.4	*		-1.74	2.88	1.14
7	2390 AV	39.92	54	-14.08	-58.22	2.88	-55.34
8	2483.5 AV	45.48	54	-8.52	-52.66	2.88	-49.78
9	2389.8 AV	39.99	54	-14.01	-58.15	2.88	-55.27
10	2484.08 AV	46.51	54	-7.49	-51.63	2.88	-48.75

Note :

1. Emission Level (dBuV/m) = EIRP Level (dBm) – 20log(d) + 104.8  
d = measurement distance in 3 meters.
2. \* : Fundamental frequency, the limit was restricted at the output power.

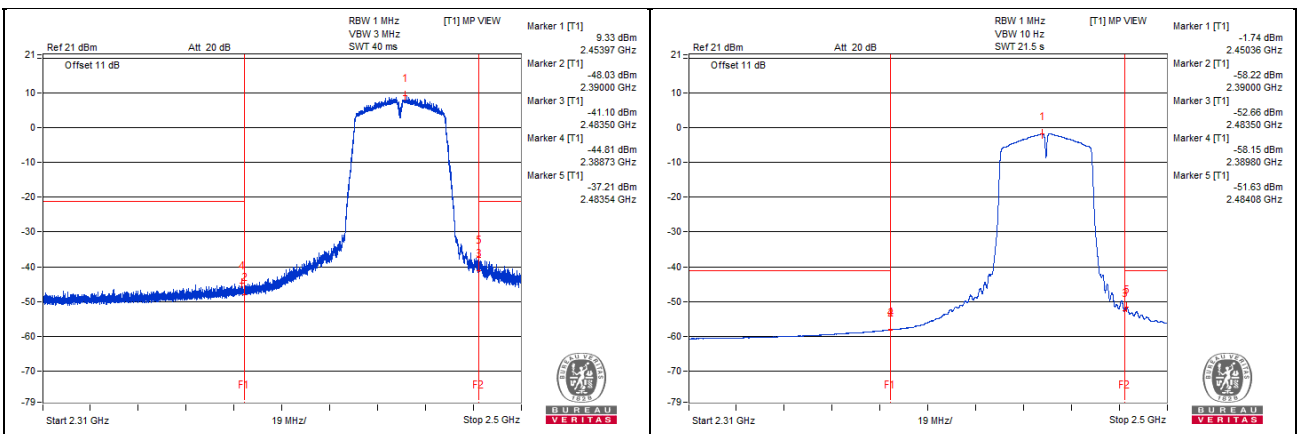

**Below 1GHz Data**  
**802.11b - Channel 6**

**Conducted spurious emission table**

No.	Frequency (MHz)	Emission Level (dBUV/m)	Limit (dBUV/m)	Margin (dB)	Raw Value (dBm)	Correction Factor (dB)	EIRP Level (dBm)
1	80.92	34.37	#		-63.77	2.88	-60.89
2	157.91	36.13	#		-62.01	2.88	-59.13
3	787.08	34.78	#		-63.36	2.88	-60.48
4	992.72	33.68	54	-20.32	-64.46	2.88	-61.58

Note :

- Emission Level (dBUV/m) = EIRP Level (dBm) – 20log(d) + 104.8  
d = measurement distance in 3 meters.
- # : Non-restricted frequency, the limit was restricted at the conducted out of band emission.

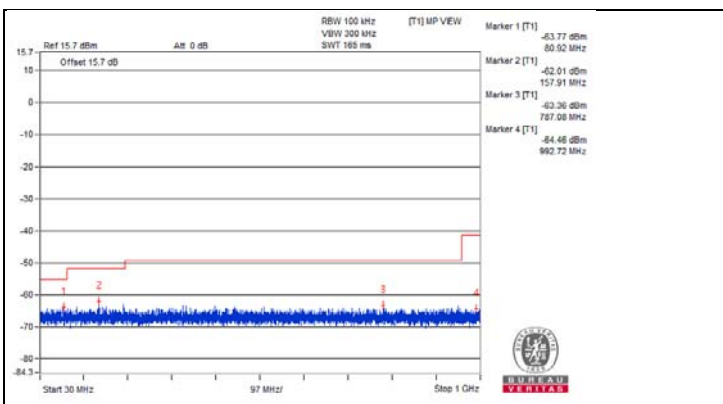

Note: Choose worse case from above and set RBW/VBW=120kHz/1MHz to verification.

**802.11b - Channel 6**

**Conducted spurious emission table**

No.	Frequency (MHz)	Emission Level (dBUV/m)	Limit (dBUV/m)	Margin (dB)	Raw Value (dBm)	Correction Factor (dB)	EIRP Level (dBm)
1	35.94	32.34	#		-65.8	2.88	-62.92
2	210.54	33.19	#		-64.95	2.88	-62.07
3	631.88	34.2	#		-63.94	2.88	-61.06
4	988.72	33.83	54	-20.17	-64.31	2.88	-61.43

Note :

- Emission Level (dBUV/m) = EIRP Level (dBm) – 20log(d) + 104.8  
d = measurement distance in 3 meters.
- # : Non-restricted frequency, the limit was restricted at the conducted out of band emission.

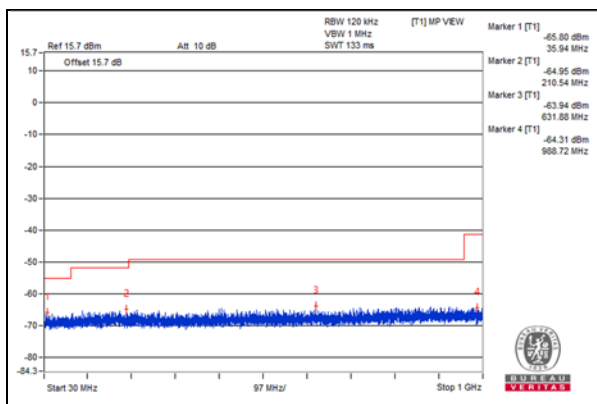

## 4.2 Conducted Emission Measurement

### 4.2.1 Limits of Conducted Emission Measurement

Frequency (MHz)	Conducted Limit (dBuV)	
	Quasi-peak	Average
0.15 - 0.5	66 - 56	56 - 46
0.50 - 5.0	56	46
5.0 - 30.0	60	50

Note: 1. The lower limit shall apply at the transition frequencies.

2. The limit decreases in line with the logarithm of the frequency in the range of 0.15 to 0.50MHz.

### 4.2.2 Test Instruments

DESCRIPTION & MANUFACTURER	MODEL NO.	SERIAL NO.	CALIBRATED DATE	CALIBRATED UNTIL
Test Receiver R&S	ESCS 30	847124/029	Oct. 23, 2019	Oct. 22, 2020
Line-Impedance Stabilization Network (for EUT) R&S	ESH3-Z5	848773/004	Oct. 23, 2019	Oct. 22, 2020
Line-Impedance Stabilization Network (for Peripheral) R&S	ESH3-Z5	835239/001	Mar. 19, 2020	Mar. 18, 2021
50 ohms Terminator	50	3	Oct. 23, 2019	Oct. 22, 2020
RF Cable	5D-FB	COCCAB-001	Sep. 27, 2019	Sep. 26, 2020
Fixed attenuator EMCI	STI02-2200-10	005	Aug. 30, 2019	Aug. 29, 2020
Software BVADT	BVADT_Cond_V7.3.7.4	NA	NA	NA

**Note:**

1. The calibration interval of the above test instruments are 12 months and the calibrations are traceable to NML/ROC and NIST/USA.
2. The test was performed in Conduction 1.
- 3 Tested Date: Apr. 17, 2020

#### 4.2.3 Test Procedures

- The EUT was placed 0.4 meters from the conducting wall of the shielded room with EUT being connected to the power mains through a line impedance stabilization network (LISN). Other support units were connected to the power mains through another LISN. The two LISNs provide 50 ohm/ 50uH of coupling impedance for the measuring instrument.
- Both lines of the power mains connected to the EUT were checked for maximum conducted interference.
- The frequency range from 150kHz to 30MHz was searched. Emission levels under (Limit - 20dB) was not recorded.

**Note:** The resolution bandwidth and video bandwidth of test receiver is 9kHz for quasi-peak detection (QP) and average detection (AV) at frequency 0.15MHz-30MHz.

#### 4.2.4 Deviation from Test Standard

No deviation.

#### 4.2.5 Test Setup

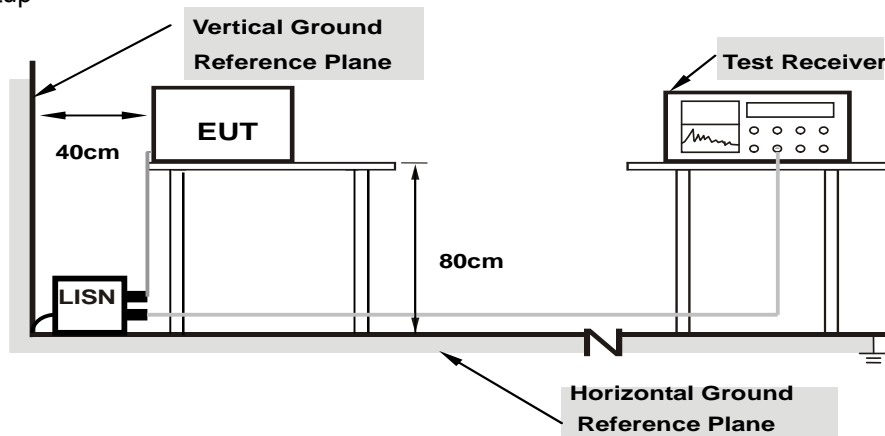

**Note:** 1.Support units were connected to second LISN.

For the actual test configuration, please refer to the attached file (Test Setup Photo).

#### 4.2.6 EUT Operating Conditions

Same as 4.1.6.

#### 4.2.7 Test Results

Phase	Line (L)	Detector Function	Quasi-Peak (QP) / Average (AV)
-------	----------	-------------------	--------------------------------

Phase Of Power : Line (L)										
No	Frequency (MHz)	Correction Factor (dB)	Reading Value (dBuV)		Emission Level (dBuV)		Limit (dBuV)		Margin (dB)	
			Q.P.	AV.	Q.P.	AV.	Q.P.	AV.	Q.P.	AV.
1	0.15000	9.99	35.70	26.13	45.69	36.12	66.00	56.00	-20.31	-19.88
2	0.20469	9.99	30.80	24.07	40.79	34.06	63.42	53.42	-22.63	-19.36
3	0.73203	10.03	30.32	26.37	40.35	36.40	56.00	46.00	-15.65	-9.60
4	3.70313	10.24	23.07	11.35	33.31	21.59	56.00	46.00	-22.69	-24.41
5	5.55859	10.36	17.23	9.26	27.59	19.62	60.00	50.00	-32.41	-30.38
6	17.56250	11.20	20.24	16.71	31.44	27.91	60.00	50.00	-28.56	-22.09

**Remarks:**

1. Q.P. and AV. are abbreviations of quasi-peak and average individually.
2. The emission levels of other frequencies were very low against the limit.
3. Margin value = Emission level – Limit value
4. Correction factor = Insertion loss + Cable loss
5. Emission Level = Correction Factor + Reading Value

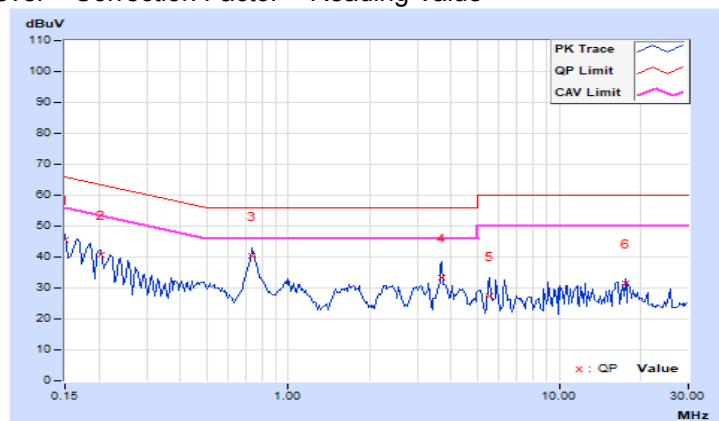

Phase	Neutral (N)	Detector Function	Quasi-Peak (QP) / Average (AV)
-------	-------------	-------------------	--------------------------------

Phase Of Power : Neutral (N)										
No	Frequency (MHz)	Correction Factor (dB)	Reading Value (dBuV)		Emission Level (dBuV)		Limit (dBuV)		Margin (dB)	
			Q.P.	AV.	Q.P.	AV.	Q.P.	AV.	Q.P.	AV.
1	0.15000	9.99	37.35	27.71	47.34	37.70	66.00	56.00	-18.66	-18.30
2	0.20859	9.99	31.64	23.87	41.63	33.86	63.26	53.26	-21.63	-19.40
<b>3</b>	<b>0.72813</b>	<b>10.03</b>	<b>29.74</b>	<b>27.36</b>	<b>39.77</b>	<b>37.39</b>	<b>56.00</b>	<b>46.00</b>	<b>-16.23</b>	<b>-8.61</b>
4	2.39844	10.14	20.06	18.02	30.20	28.16	56.00	46.00	-25.80	-17.84
5	3.66016	10.20	24.10	18.15	34.30	28.35	56.00	46.00	-21.70	-17.65
6	17.56250	10.98	20.26	16.85	31.24	27.83	60.00	50.00	-28.76	-22.17

**Remarks:**

1. Q.P. and AV. are abbreviations of quasi-peak and average individually.
2. The emission levels of other frequencies were very low against the limit.
3. Margin value = Emission level – Limit value
4. Correction factor = Insertion loss + Cable loss
5. Emission Level = Correction Factor + Reading Value

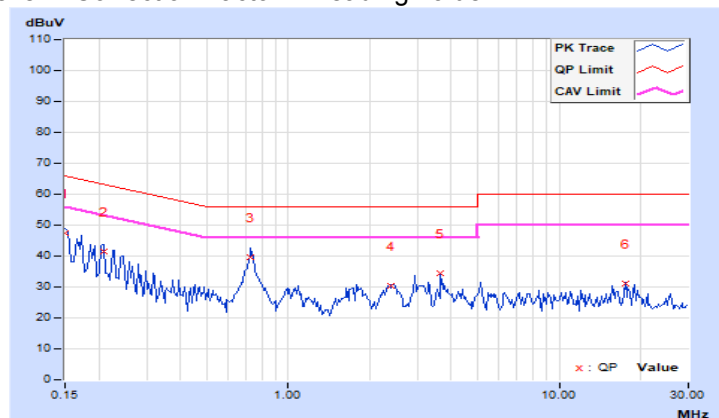



### 4.3 6dB Bandwidth Measurement

#### 4.3.1 Limits of 6dB Bandwidth Measurement

The minimum of 6dB Bandwidth Measurement is 0.5 MHz.

#### 4.3.2 Test Setup

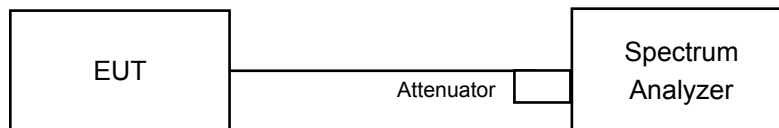

#### 4.3.3 Test Instruments

Refer to section 4.1.2 to get information of above instrument.

#### 4.3.4 Test Procedure

- a. Set resolution bandwidth (RBW) = 100kHz
- b. Set the video bandwidth (VBW)  $\geq 3 \times$  RBW, Detector = Peak.
- c. Trace mode = max hold.
- d. Sweep = auto couple.
- e. Measure the maximum width of the emission that is constrained by the frequencies associated with the two amplitude points (upper and lower) that are attenuated by 6 dB relative to the maximum level measured in the fundamental emission. In order to obtain results more easily, change max hold to view. It has no effect on the result

#### 4.3.5 Deviation from Test Standard

No deviation.

#### 4.3.6 EUT Operating Conditions

The software provided by client to enable the EUT under transmission condition continuously at lowest, middle and highest channel frequencies individually.

### 4.3.7 Test Result (Mode 1)

#### 802.11n (HT20)

Channel	Frequency (MHz)	6dB Bandwidth (MHz)		Minimum Limit (MHz)	Pass / Fail
		Chain 0	Chain 1		
1	2412	17.66	17.66	0.5	Pass
6	2437	17.68	17.67	0.5	Pass
11	2462	17.64	17.65	0.5	Pass

#### 802.11n (HT40)

Channel	Frequency (MHz)	6dB Bandwidth (MHz)		Minimum Limit (MHz)	Pass / Fail
		Chain 0	Chain 1		
3	2422	36.49	36.43	0.5	Pass
6	2437	35.44	35.85	0.5	Pass
9	2452	36.31	36.44	0.5	Pass

#### Spectrum Plot of Worst Value

##### 802.11n (HT20)\_Chain 0 / CH11

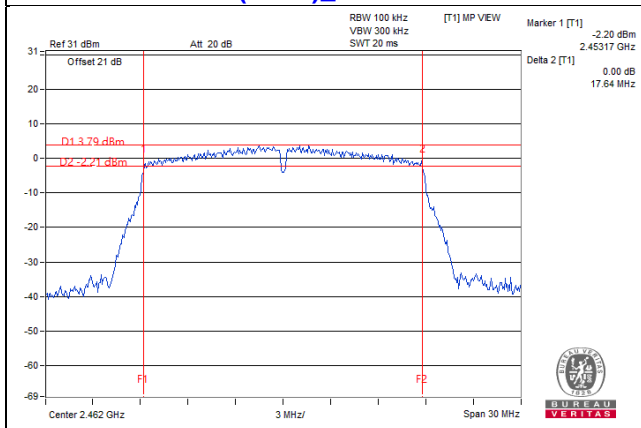

##### 802.11n (HT40)\_Chain 0 / CH6

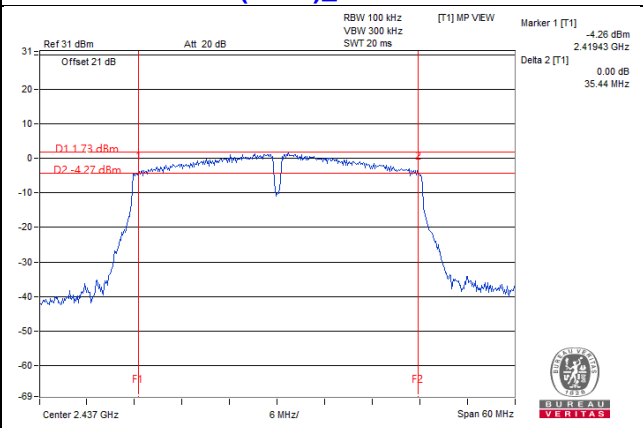

#### 4.3.8 Test Result (Mode 2)

##### 802.11b

Channel	Frequency (MHz)	6dB Bandwidth (MHz)	Minimum Limit (MHz)	Pass / Fail
1	2412	9.08	0.5	Pass
6	2437	8.58	0.5	Pass
11	2462	8.57	0.5	Pass

##### 802.11g

Channel	Frequency (MHz)	6dB Bandwidth (MHz)	Minimum Limit (MHz)	Pass / Fail
1	2412	15.20	0.5	Pass
6	2437	15.34	0.5	Pass
11	2462	16.39	0.5	Pass

##### 802.11n (HT20)

Channel	Frequency (MHz)	6dB Bandwidth (MHz)	Minimum Limit (MHz)	Pass / Fail
1	2412	17.69	0.5	Pass
6	2437	17.68	0.5	Pass
11	2462	17.65	0.5	Pass

##### 802.11n (HT40)

Channel	Frequency (MHz)	6dB Bandwidth (MHz)	Minimum Limit (MHz)	Pass / Fail
3	2422	36.49	0.5	Pass
6	2437	35.81	0.5	Pass
9	2452	36.44	0.5	Pass

### Spectrum Plot of Worst Value

#### 802.11b / CH11

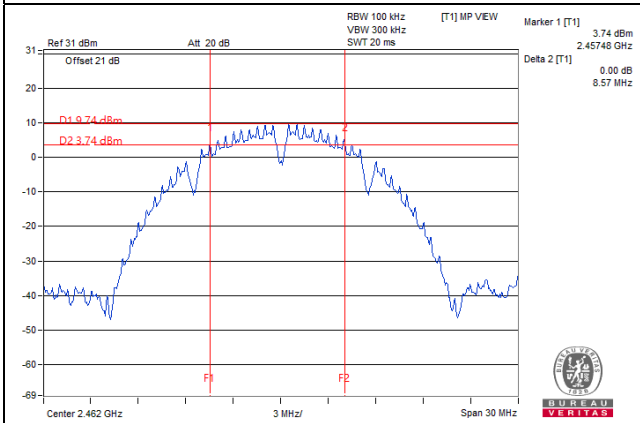

#### 802.11g / CH1

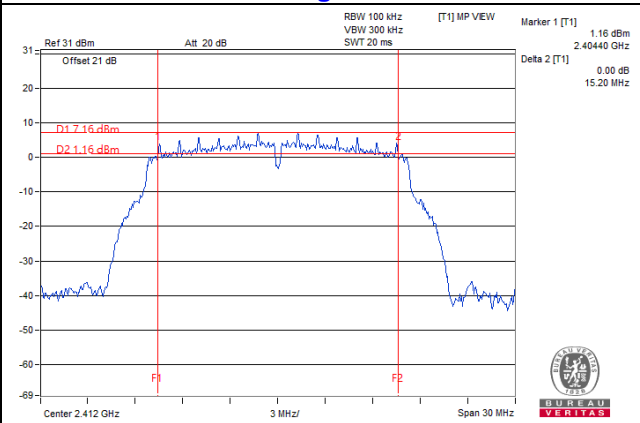

#### 802.11n (HT20) / CH11

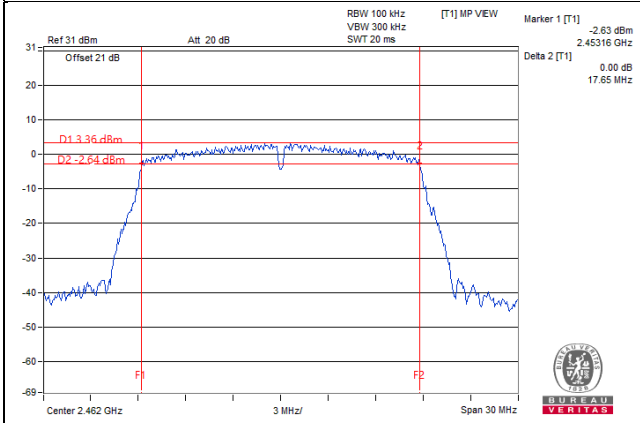

#### 802.11n (HT40) / CH6

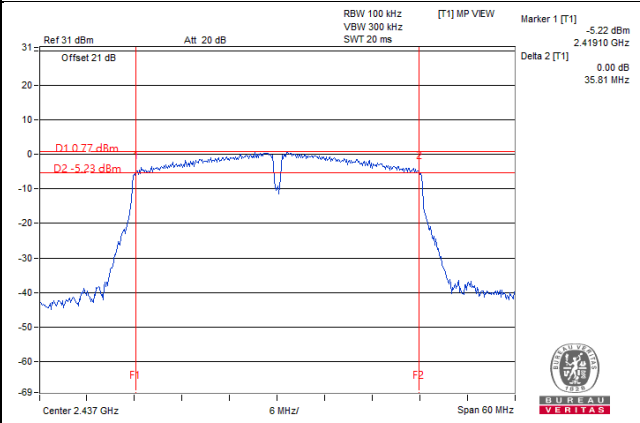

## 4.4 Conducted Output Power Measurement

### 4.4.1 Limits of Conducted Output Power Measurement

For systems using digital modulation in the 2400–2483.5 MHz bands: 1 Watt (30dBm)

Per KDB 662911 D01 Multiple Transmitter Output Method of conducted output power measurement on IEEE 802.11 devices,

Array Gain = 0 dB (i.e., no array gain) for  $N_{ANT} \leq 4$ ;

Array Gain = 0 dB (i.e., no array gain) for channel widths  $\geq 40$  MHz for any  $N_{ANT}$ ;

Array Gain =  $5 \log(N_{ANT}/N_{SS})$  dB or 3 dB, whichever is less for 20-MHz channel widths with  $N_{ANT} \geq 5$ .

For power measurements on all other devices: Array Gain =  $10 \log(N_{ANT}/N_{SS})$  dB.

### 4.4.2 Test Setup

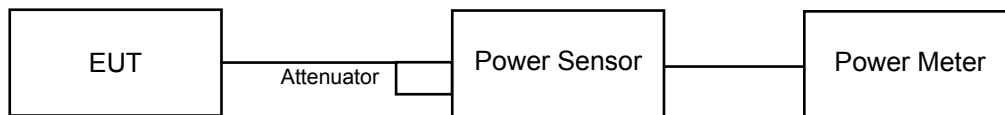

### 4.4.3 Test Instruments

Refer to section 4.1.2 to get information of above instrument.

### 4.4.4 Test Procedures

A peak power sensor was used on the output port of the EUT. A power meter was used to read the response of the peak power sensor. Record the power level.

Average power sensor was used to perform output power measurement, trigger and gating function of wide band power meter is enabled to measure max output power of TX on burst. Duty factor is not added to measured value.

### 4.4.5 Deviation from Test Standard

No deviation.

### 4.4.6 EUT Operating Conditions

Same as Item 4.3.6.

#### 4.4.7 Test Results (Mode 1)

#### FOR PEAK POWER

##### 802.11n (HT20)

Chan.	Chan. Freq. (MHz)	Peak Power (dBm)		Total Power (mW)	Total Power (dBm)	Limit (dBm)	Pass / Fail
		Chain 0	Chain 1				
1	2412	23.99	23.48	473.454	26.75	30.00	Pass
6	2437	24.04	23.38	471.284	26.73	30.00	Pass
11	2462	23.94	23.07	450.51	26.54	30.00	Pass

##### 802.11n (HT40)

Chan.	Chan. Freq. (MHz)	Peak Power (dBm)		Total Power (mW)	Total Power (dBm)	Limit (dBm)	Pass / Fail
		Chain 0	Chain 1				
3	2422	24.12	22.23	425.335	26.29	30.00	Pass
6	2437	23.96	23.19	457.335	26.60	30.00	Pass
9	2452	24.02	22.18	417.544	26.21	30.00	Pass

#### FOR AVERAGE POWER

##### 802.11n (HT20)

Chan.	Chan. Freq. (MHz)	Average Power (dBm)		Total Average Power (mW)	Total Average Power (dBm)
		Chain 0	Chain 1		
1	2412	16.38	16.12	84.377	19.26
6	2437	16.77	16.27	89.898	19.54
11	2462	16.31	15.49	78.156	18.93

##### 802.11n (HT40)

Chan.	Chan. Freq. (MHz)	Average Power (dBm)		Total Average Power (mW)	Total Average Power (dBm)
		Chain 0	Chain 1		
3	2422	16.32	14.55	71.365	18.53
6	2437	16.79	16.18	89.248	19.51
9	2452	16.30	14.52	70.972	18.51

#### 4.4.8 Test Results (Mode 2)

#### FOR PEAK POWER

##### 802.11b

Chan.	Chan. Freq. (MHz)	Peak Power (mW)	Peak Power (dBm)	Limit (dBm)	Pass / Fail
1	2412	88.716	19.48	30.00	Pass
6	2437	91.411	19.61	30.00	Pass
11	2462	89.536	19.52	30.00	Pass

##### 802.11g

Chan.	Chan. Freq. (MHz)	Peak Power (mW)	Peak Power (dBm)	Limit (dBm)	Pass / Fail
1	2412	276.694	24.42	30.00	Pass
6	2437	278.612	24.45	30.00	Pass
11	2462	284.446	24.54	30.00	Pass

##### 802.11n (HT20)

Chan.	Chan. Freq. (MHz)	Peak Power (mW)	Peak Power (dBm)	Limit (dBm)	Pass / Fail
1	2412	224.388	23.51	30.00	Pass
6	2437	209.411	23.21	30.00	Pass
11	2462	219.28	23.41	30.00	Pass

##### 802.11n (HT40)

Chan.	Chan. Freq. (MHz)	Peak Power (mW)	Peak Power (dBm)	Limit (dBm)	Pass / Fail
3	2422	239.332	23.79	30.00	Pass
6	2437	216.272	23.35	30.00	Pass
9	2452	212.324	23.27	30.00	Pass

## FOR AVERAGE POWER

### 802.11b

Chan.	Chan. Freq. (MHz)	Average Power (mW)	Average Power (dBm)
1	2412	54.576	17.37
6	2437	55.463	17.44
11	2462	54.702	17.38

### 802.11g

Chan.	Chan. Freq. (MHz)	Average Power (mW)	Average Power (dBm)
1	2412	51.761	17.14
6	2437	54.075	17.33
11	2462	54.325	17.35

### 802.11n (HT20)

Chan.	Chan. Freq. (MHz)	Average Power (mW)	Average Power (dBm)
1	2412	41.879	16.22
6	2437	40.551	16.08
11	2462	40.926	16.12

### 802.11n (HT40)

Chan.	Chan. Freq. (MHz)	Average Power (mW)	Average Power (dBm)
3	2422	44.463	16.48
6	2437	41.783	16.21
9	2452	40.926	16.12



## 4.5 Power Spectral Density Measurement

### 4.5.1 Limits of Power Spectral Density Measurement

The Maximum of Power Spectral Density Measurement is 8dBm in any 3 kHz.

### 4.5.2 Test Setup



### 4.5.3 Test Instruments

Refer to section 4.1.2 to get information of above instrument.

### 4.5.4 Test Procedure

- a. Set analyzer center frequency to DTS channel center frequency.
- b. Set the span to 1.5 times the DTS bandwidth.
- c. Set the RBW to:  $3 \text{ kHz} \leq \text{RBW} \leq 100 \text{ kHz}$ .
- d. Set the VBW  $\geq 3 \times \text{RBW}$ .
- e. Detector = peak.
- f. Sweep time = auto couple.
- g. Trace mode = max hold.
- h. Allow trace to fully stabilize.
- i. Use the peak marker function to determine the maximum amplitude level within the RBW.  
In order to obtain results more easily, change max hold to view. It has no effect on the result

### 4.5.5 Deviation from Test Standard

No deviation.

### 4.5.6 EUT Operating Condition

Same as Item 4.3.6

#### 4.5.7 Test Results (Mode 1)

##### 802.11n (HT20)

Chan.	Chan. Freq. (MHz)	PSD (dBm/3kHz)		Total PSD (dBm/3kHz)	PSD Limit (dBm/3kHz)	Pass / Fail
		Chain 0	Chain 1			
1	2412	-7.15	-7.90	-4.50	8.00	Pass
6	2437	-6.15	-7.28	-3.67	8.00	Pass
11	2462	-7.73	-7.97	-4.84	8.00	Pass

Note: The directional gain =  $10 \log[(10^{G0/10} + 10^{G1/10}) / 2] = 3.27 \text{ dBi} < 6 \text{ dBi}$ , so the power density limit shall not be reduced.

##### 802.11n (HT40)

Chan.	Chan. Freq. (MHz)	PSD (dBm/3kHz)		Total PSD (dBm/3kHz)	PSD Limit (dBm/3kHz)	Pass / Fail
		Chain 0	Chain 1			
3	2422	-10.37	-12.80	-8.41	8.00	Pass
6	2437	-9.13	-10.96	-6.94	8.00	Pass
9	2452	-10.18	-13.10	-8.39	8.00	Pass

Note: The directional gain =  $10 \log[(10^{G0/10} + 10^{G1/10}) / 2] = 3.27 \text{ dBi} < 6 \text{ dBi}$ , so the power density limit shall not be reduced.

#### Spectrum Plot of Worst Value

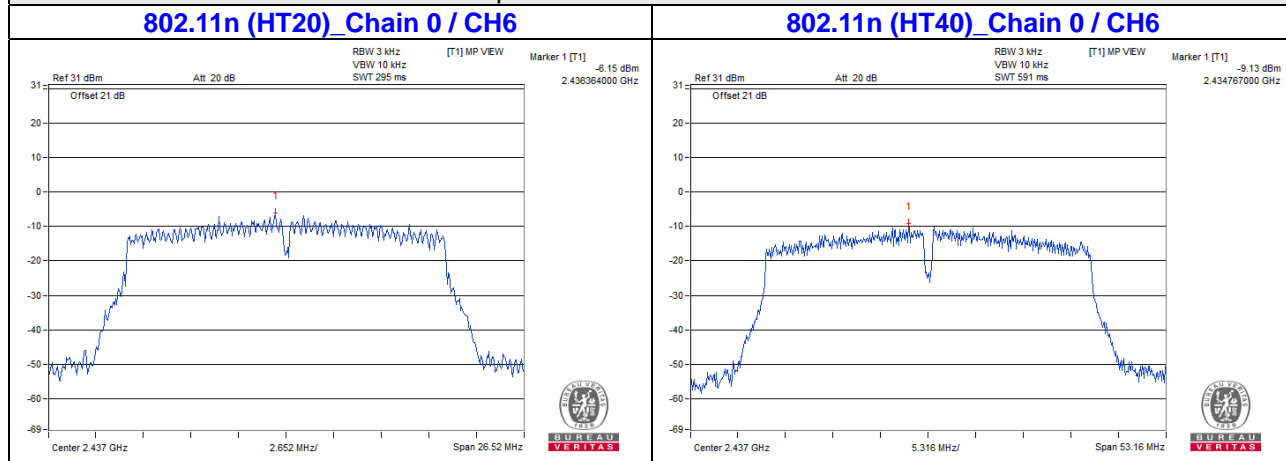

#### 4.5.8 Test Results (Mode 2)

##### 802.11b

Chan.	Chan. Freq. (MHz)	PSD (dBm/3kHz)	PSD Limit (dBm/3kHz)	Pass / Fail
1	2412	-3.72	8.00	Pass
6	2437	-3.22	8.00	Pass
11	2462	-4.44	8.00	Pass

##### 802.11g

Chan.	Chan. Freq. (MHz)	PSD (dBm/3kHz)	PSD Limit (dBm/3kHz)	Pass / Fail
1	2412	-6.93	8.00	Pass
6	2437	-6.42	8.00	Pass
11	2462	-6.89	8.00	Pass

##### 802.11n (HT20)

Chan.	Chan. Freq. (MHz)	PSD (dBm/3kHz)	PSD Limit (dBm/3kHz)	Pass / Fail
1	2412	-7.85	8.00	Pass
6	2437	-8.43	8.00	Pass
11	2462	-7.93	8.00	Pass

##### 802.11n (HT40)

Chan.	Chan. Freq. (MHz)	PSD (dBm/3kHz)	PSD Limit (dBm/3kHz)	Pass / Fail
3	2422	-11.07	8.00	Pass
6	2437	-10.49	8.00	Pass
9	2452	-11.05	8.00	Pass

### Spectrum Plot of Worst Value

#### 802.11b / CH6

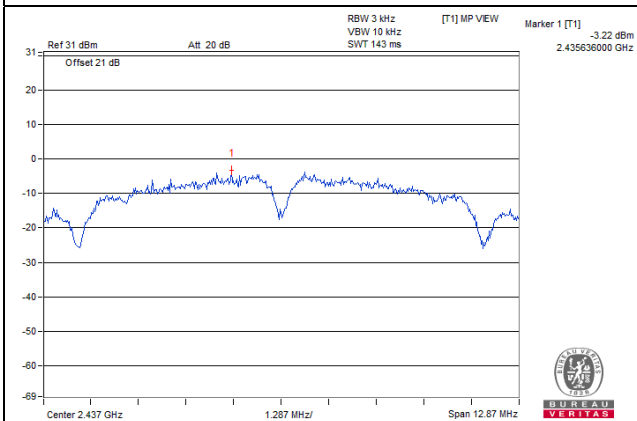

#### 802.11g CH6

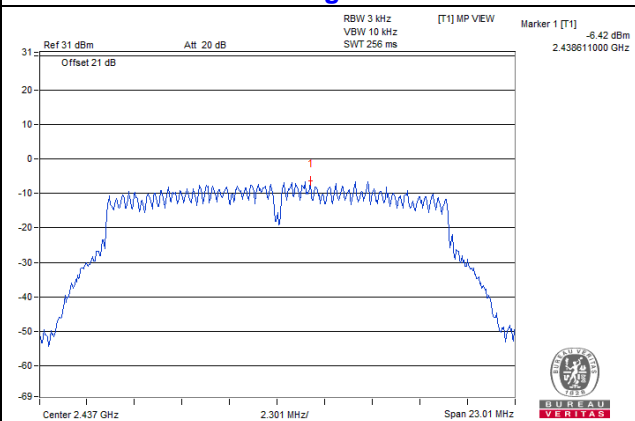

#### 802.11n (HT20) CH1

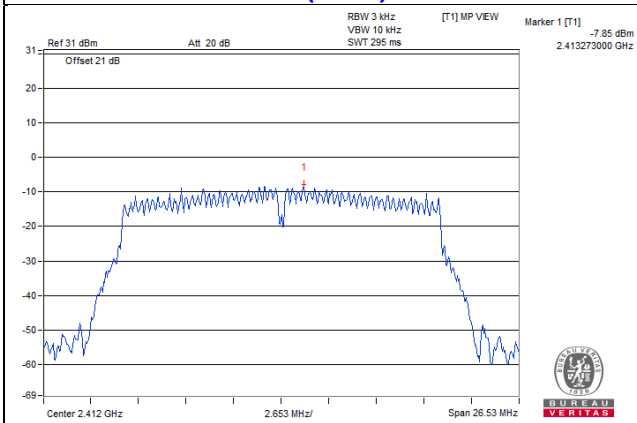

#### 802.11n (HT40) / CH6

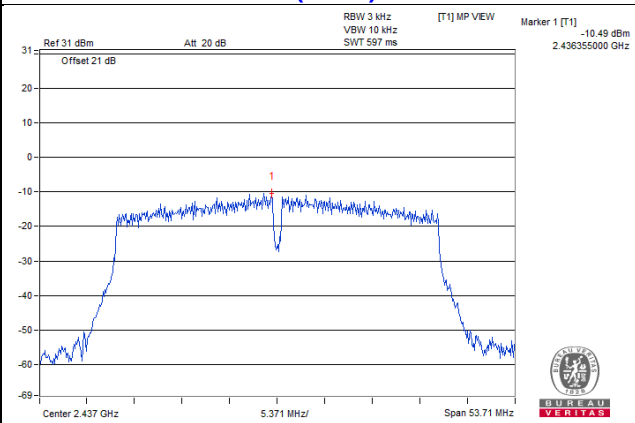

## 4.6 Conducted Out of Band Emission Measurement

### 4.6.1 Limits of Conducted Out of Band Emission Measurement

Below 20dB of the highest emission level of operating band (in 100kHz Resolution Bandwidth).

### 4.6.2 Test Setup

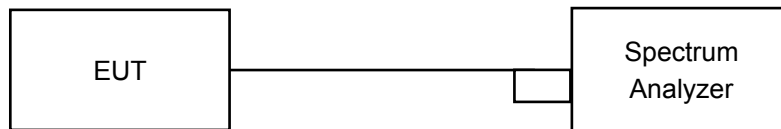

### 4.6.3 Test Instruments

Refer to section 4.1.2 to get information of above instrument.

### 4.6.4 Test Procedure

#### MEASUREMENT PROCEDURE REF

1. Set the RBW = 100 kHz.
2. Set the VBW  $\geq$  300 kHz.
3. Detector = peak.
4. Sweep time = auto couple.
5. Trace mode = max hold.
6. Allow trace to fully stabilize.
7. Use the peak marker function to determine the maximum power level in any 100 kHz band segment within the fundamental EBW.. In order to obtain results more easily, change max hold to view. It has no effect on the result.

#### MEASUREMENT PROCEDURE OOB

1. Set RBW = 100 kHz.
2. Set VBW  $\geq$  300 kHz.
3. Detector = peak.
4. Sweep = auto couple.
5. Trace Mode = max hold.
6. Allow trace to fully stabilize.
7. Use the peak marker function to determine the maximum amplitude level.  
In order to obtain results more easily, change max hold to view. It has no effect on the result.

### 4.6.5 Deviation from Test Standard

No deviation.

### 4.6.6 EUT Operating Condition

Same as Item 4.3.6

### 4.6.7 Test Results (Mode 1)

The spectrum plots are attached on the following pages. D1 line indicates the highest level, and D2 line indicates the 20dB offset below D1. It shows compliance with the requirement.

802.11n (HT20)  
Chain 0

CH 1

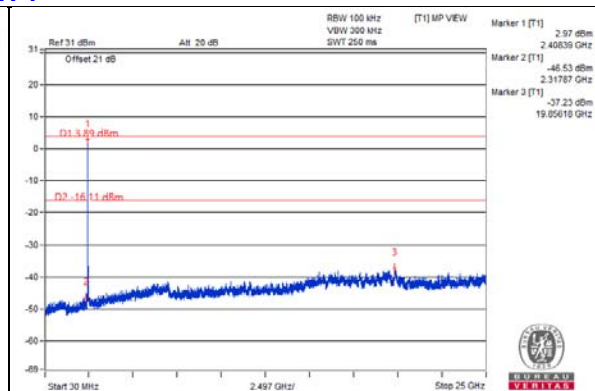
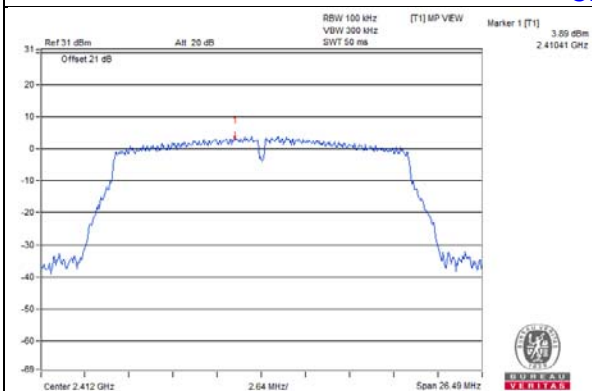

CH 6

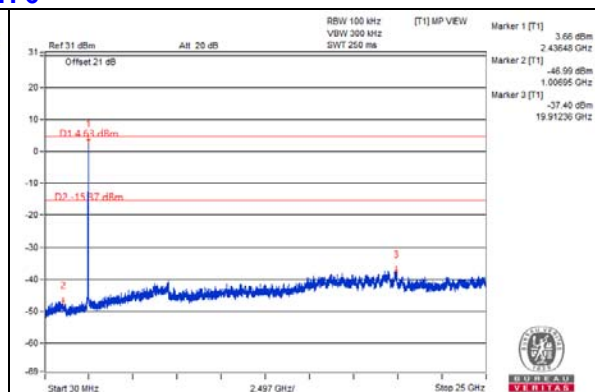
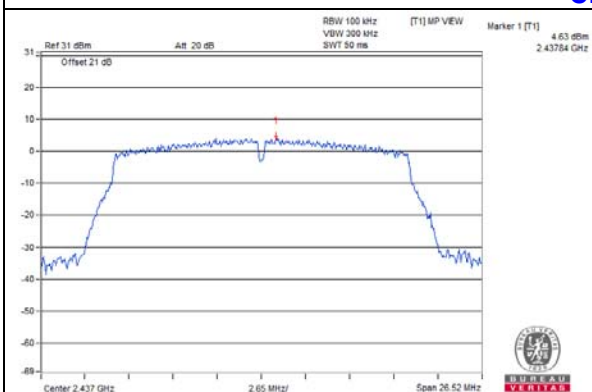

CH 11

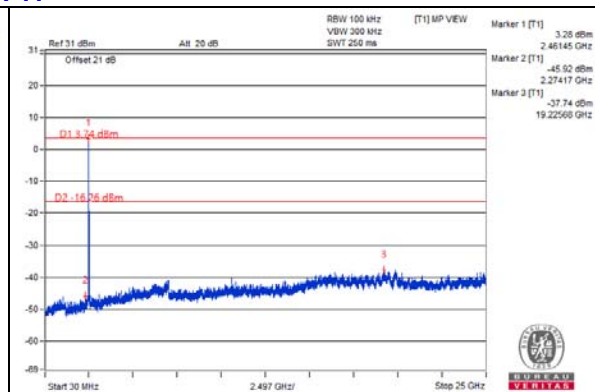
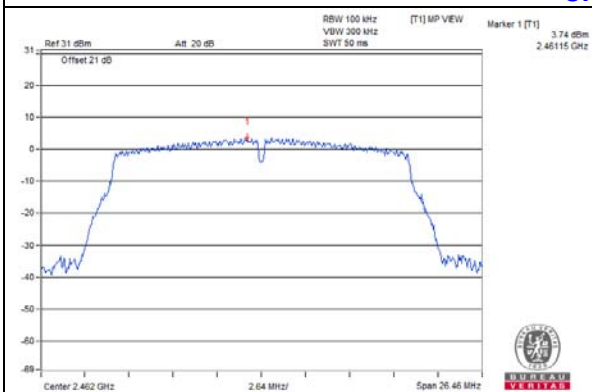

CH 1 Band edge

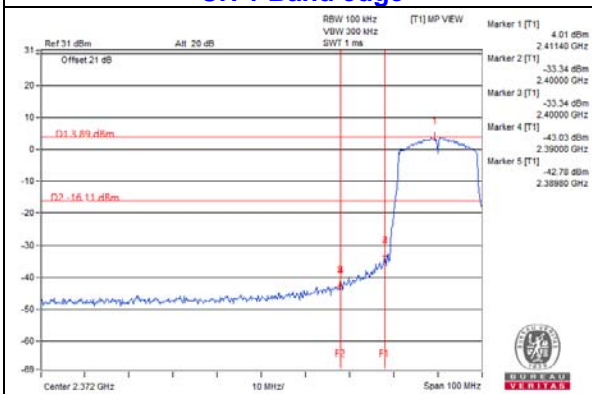

CH 11 Band edge

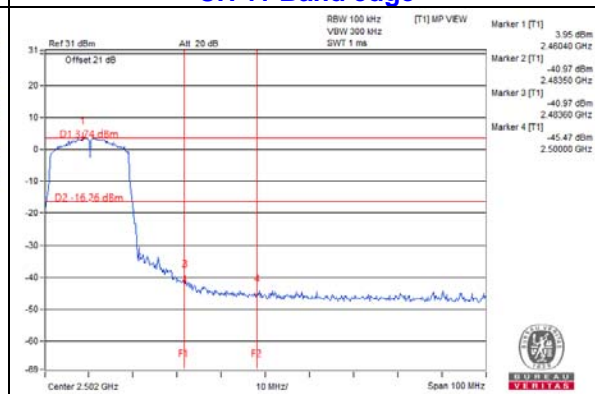

### Chain 1

#### CH 1

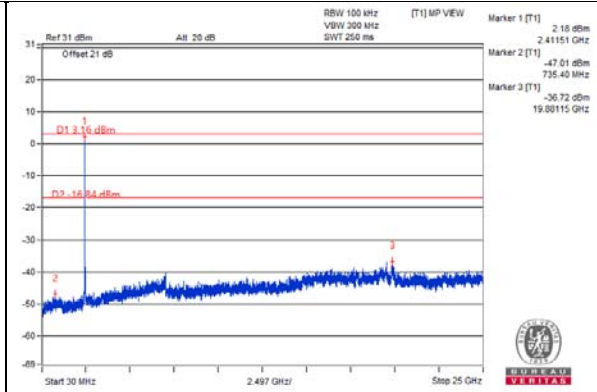
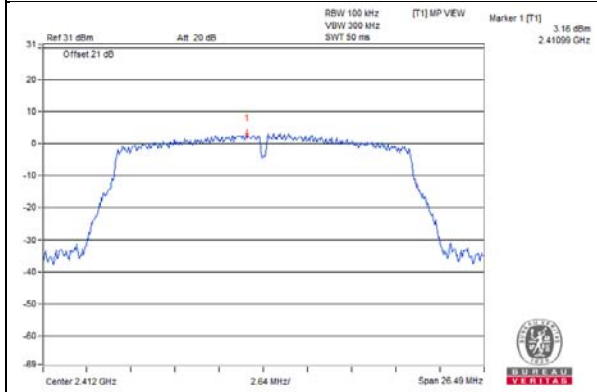

#### CH 6

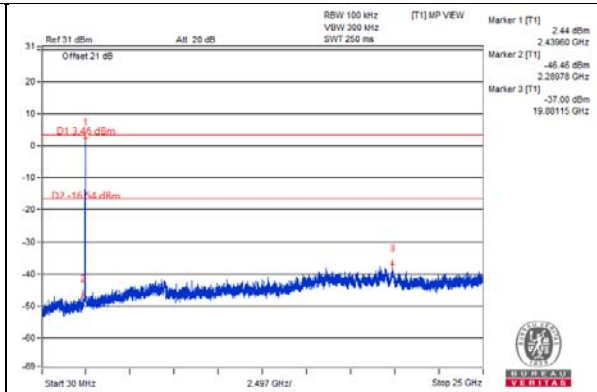
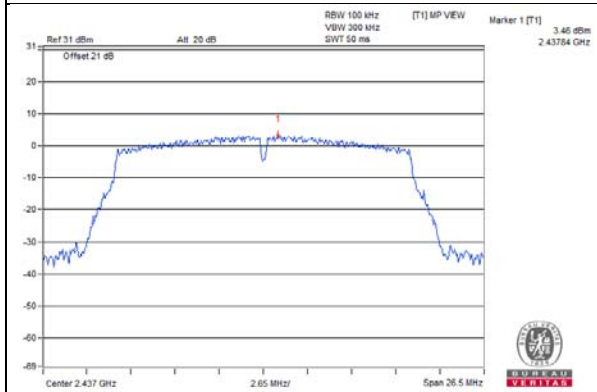

#### CH 11

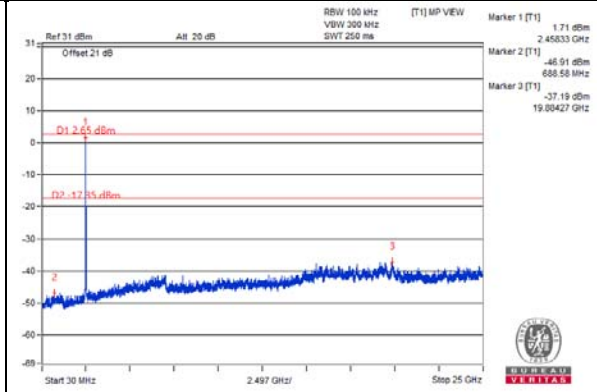
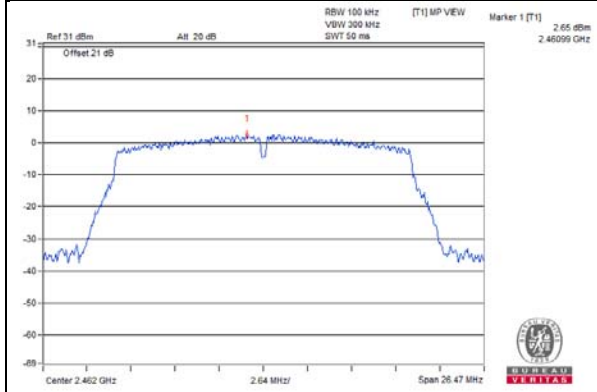

#### CH 1 Band edge

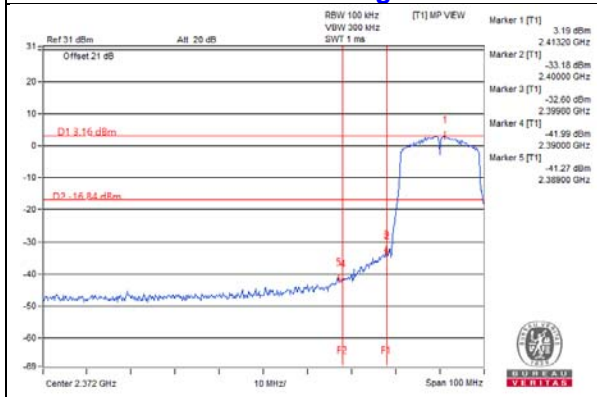

#### CH 11 Band edge

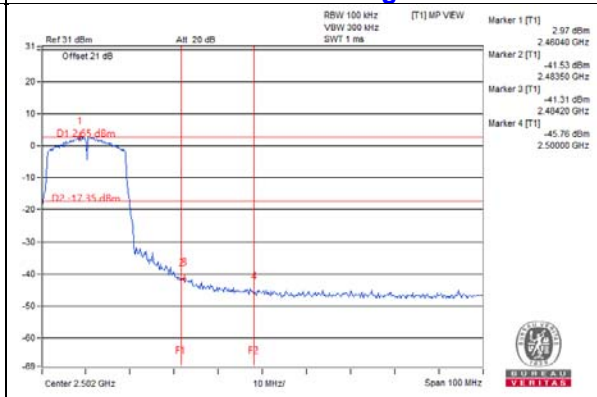

802.11n (HT40)  
Chain 0

CH 3

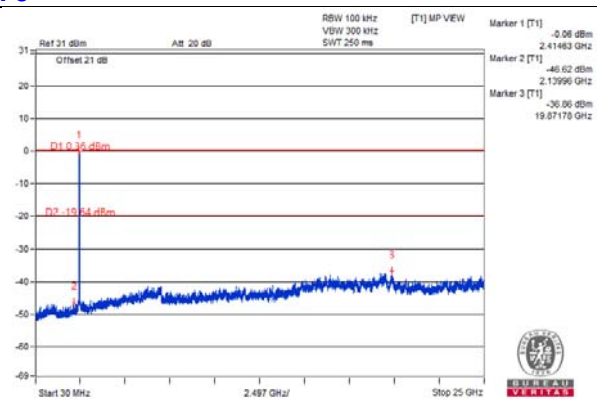
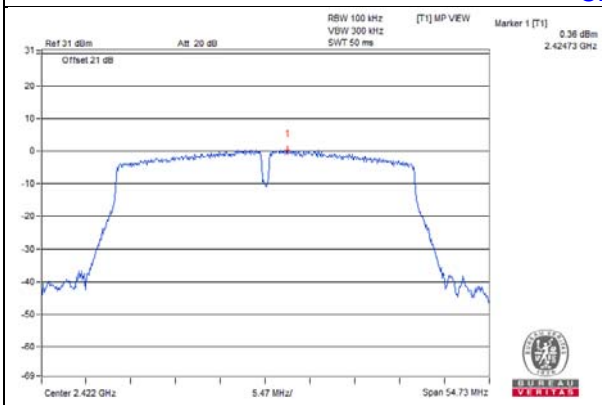

CH 6

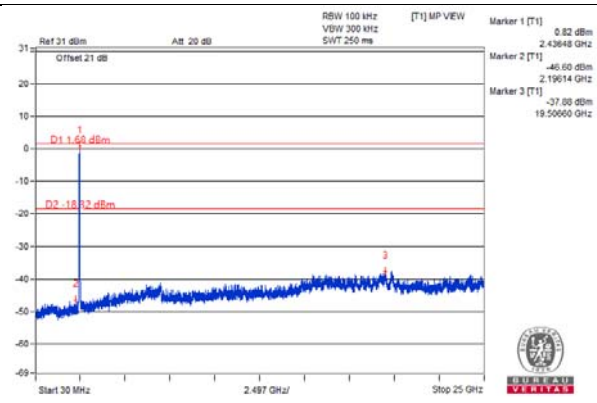
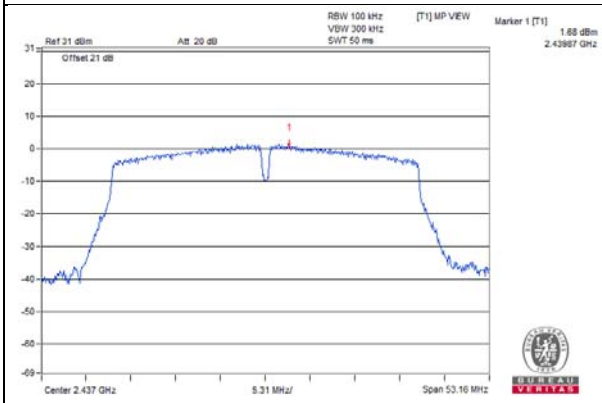

CH 9

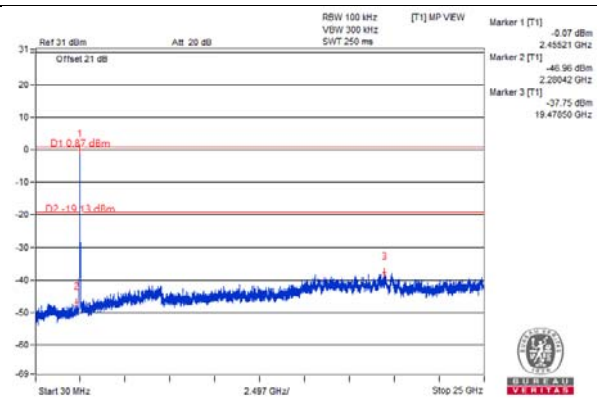
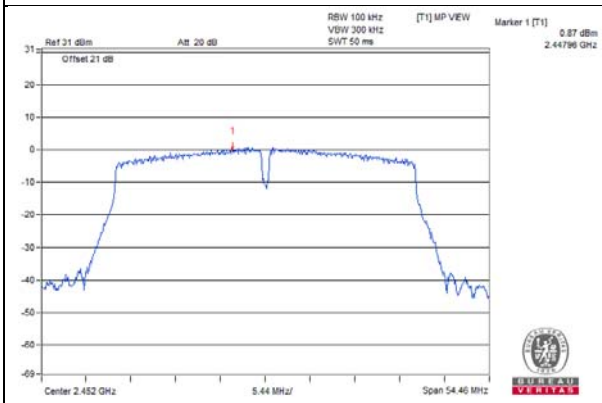

CH 3 Band edge

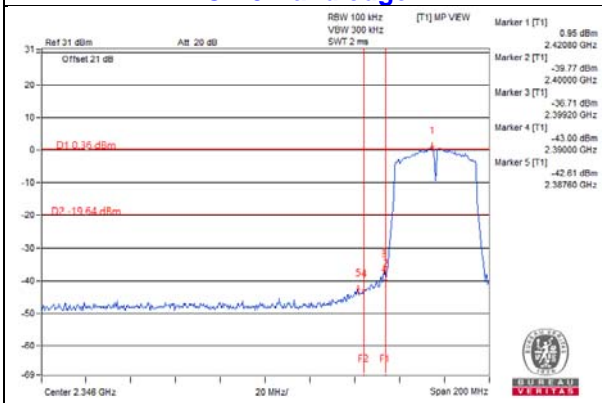

CH 9 Band edge

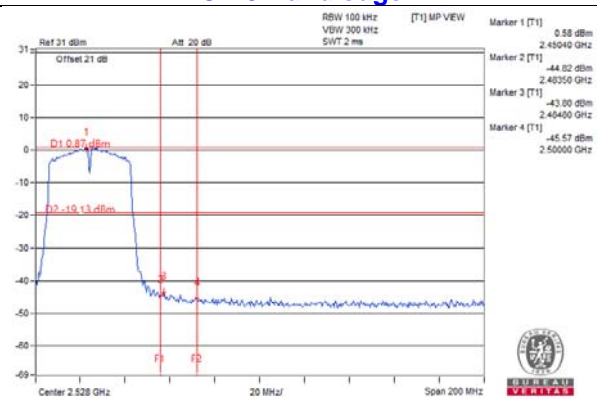



Chain 1

CH 3

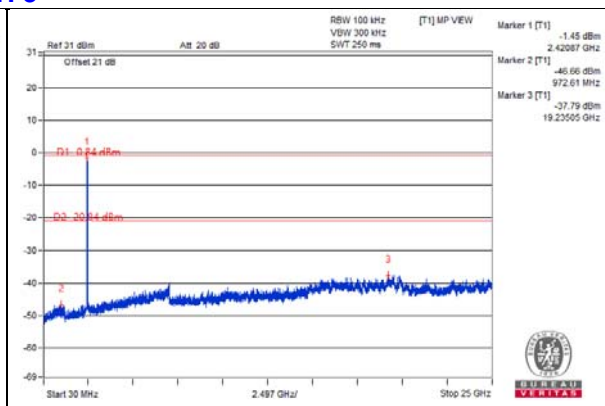
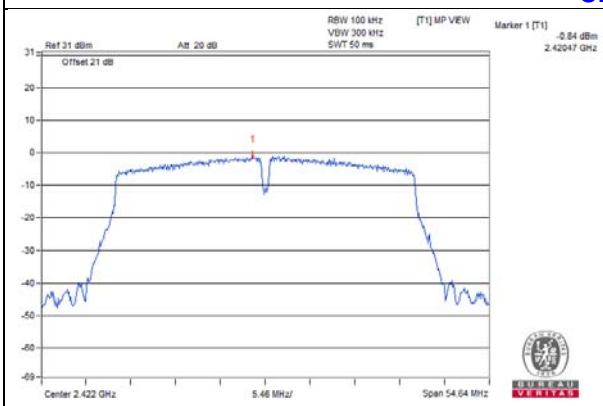

CH 6

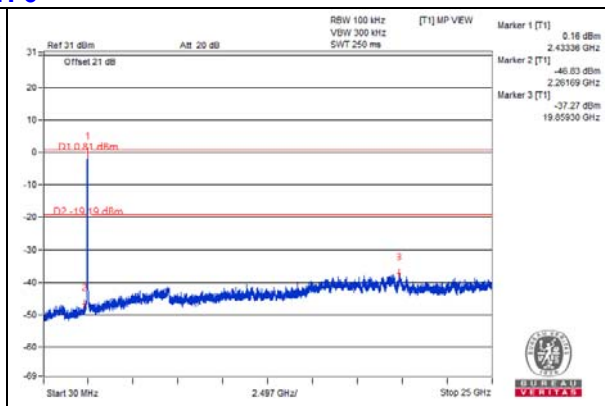
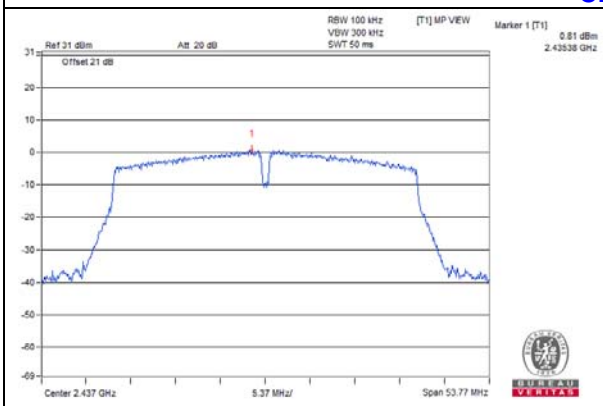

CH 9

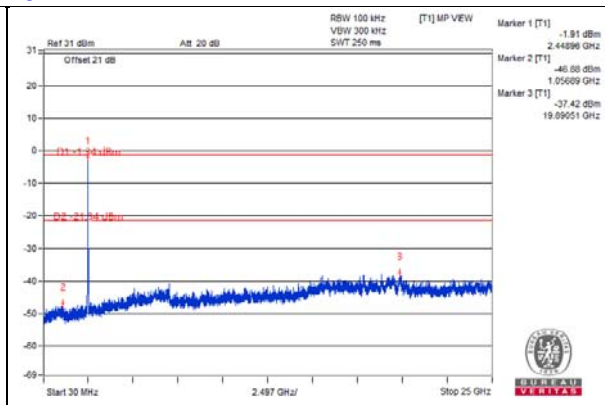
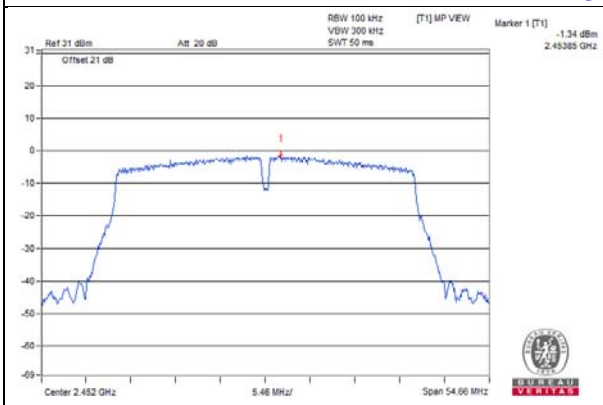

CH 3 Band edge

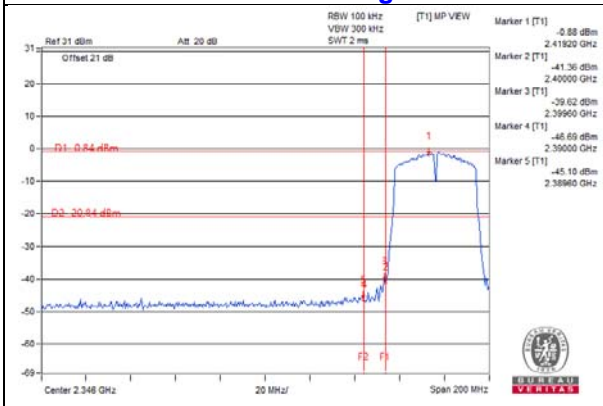

CH 9 Band edge

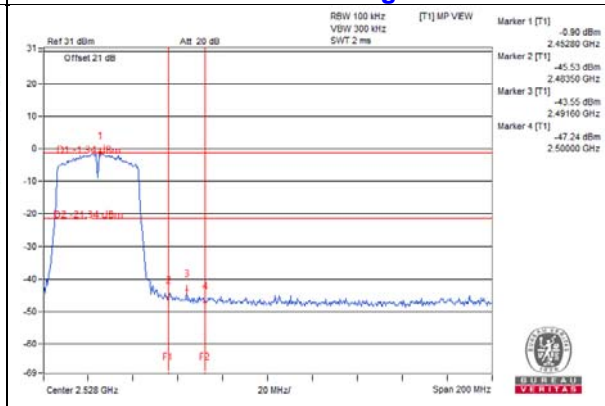

### 4.6.8 Test Results (Mode 2)

The spectrum plots are attached on the following pages. D1 line indicates the highest level, and D2 line indicates the 20dB offset below D1. It shows compliance with the requirement.

#### 802.11b

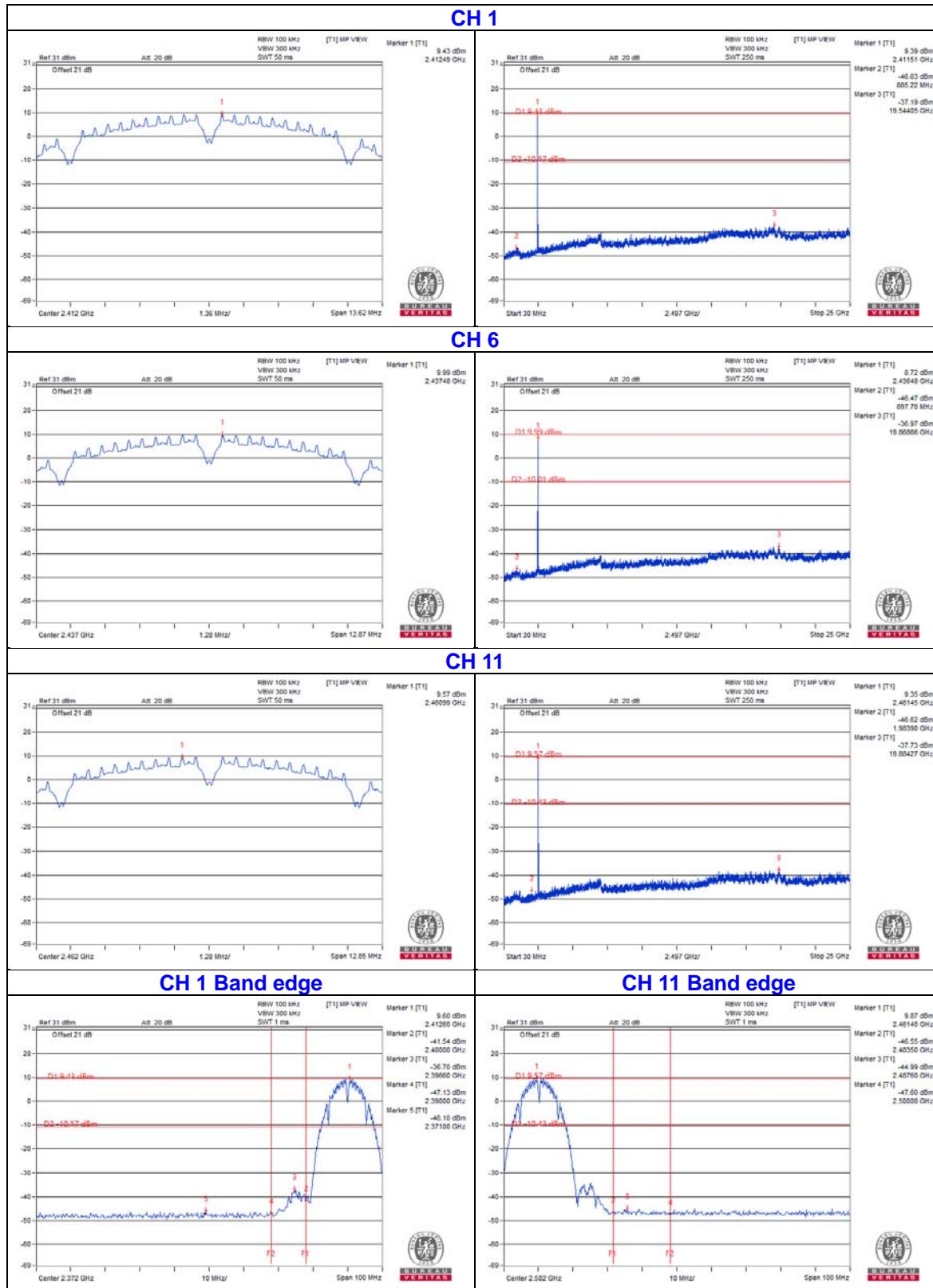

802.11g

CH 1

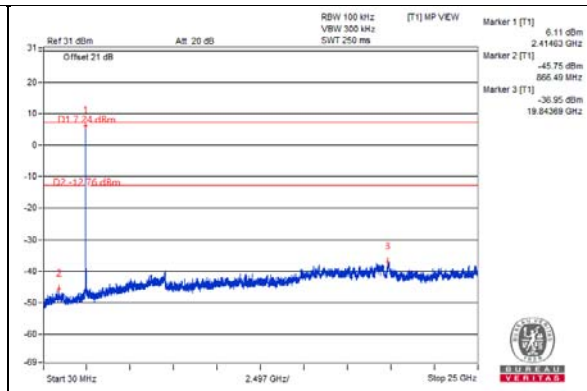
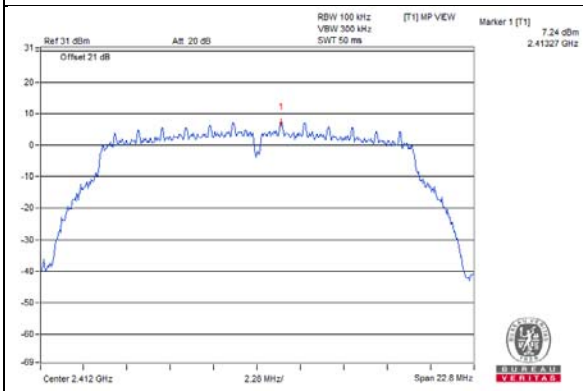

CH 6

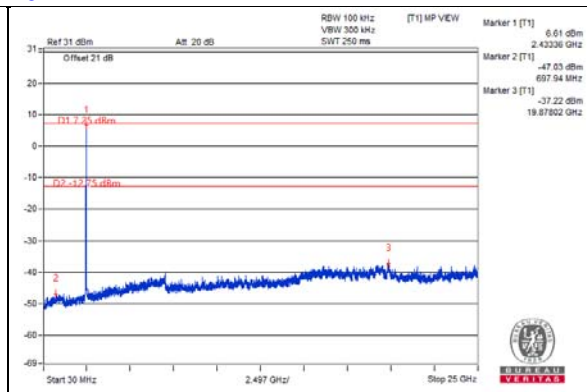
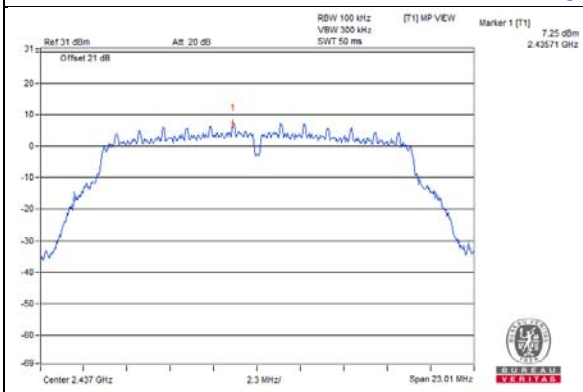

CH 11

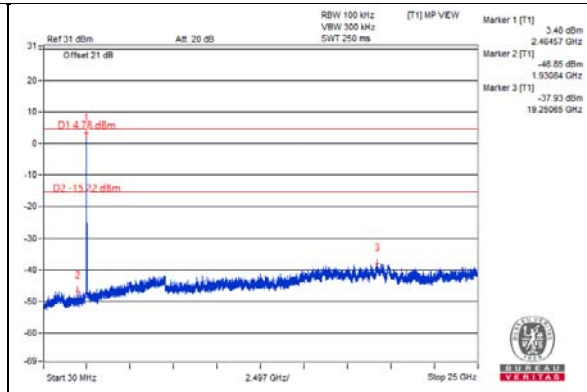
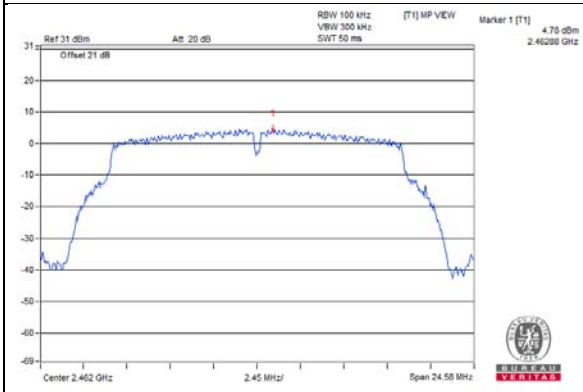

CH 1 Band edge

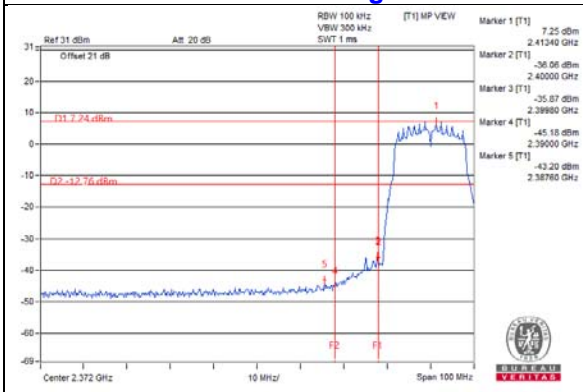

CH 11 Band edge

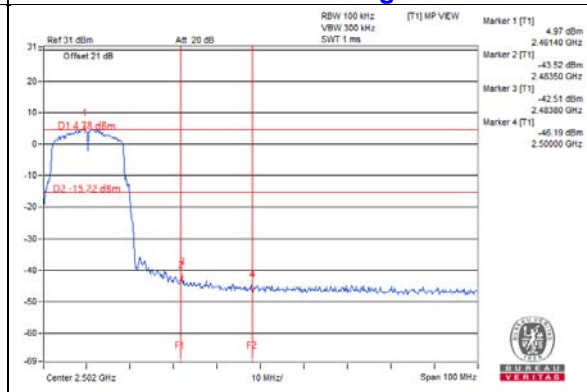

802.11n (HT20)

CH 1

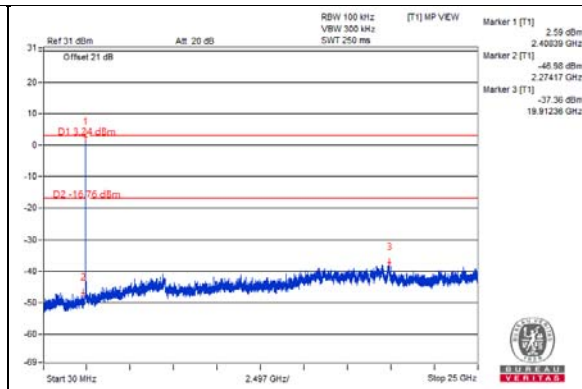
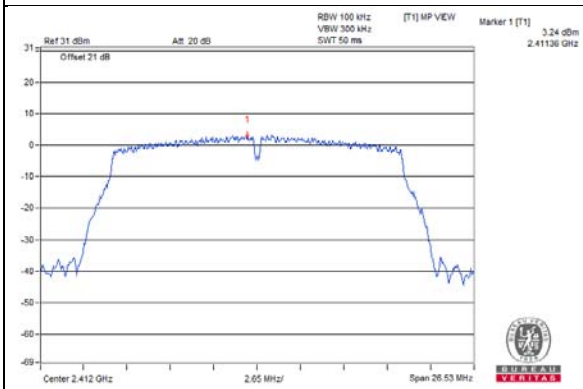

CH 6

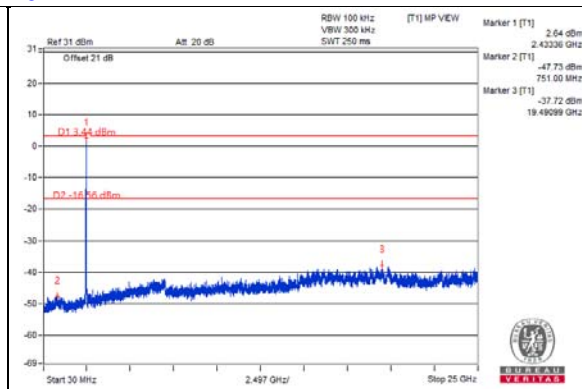
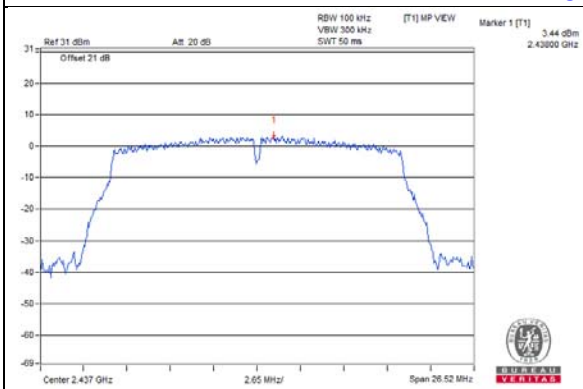

CH 11

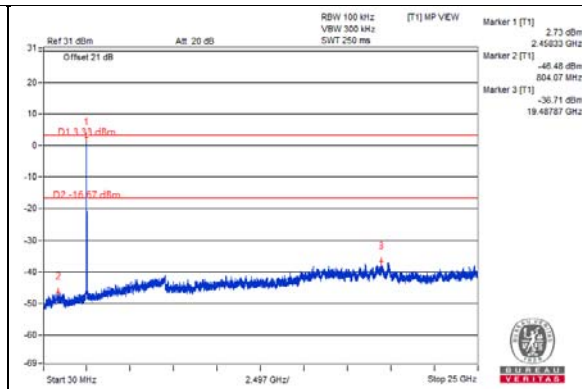
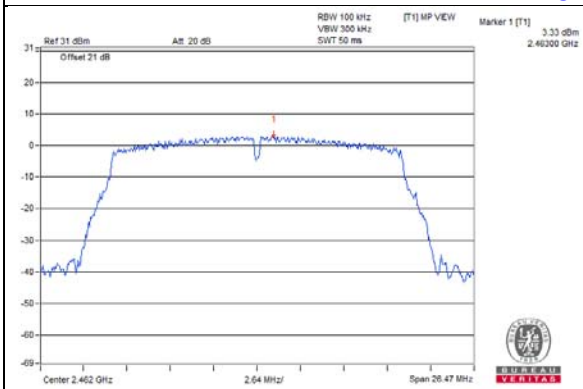

CH 1 Band edge

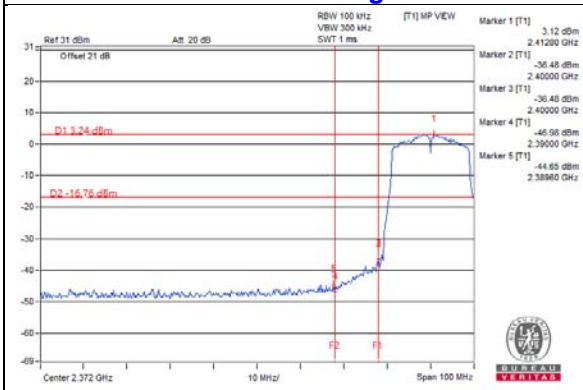

CH 11 Band edge

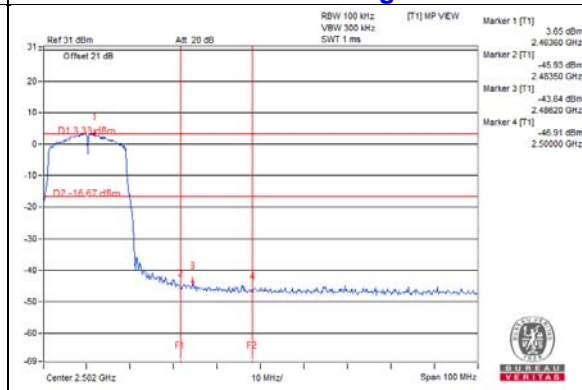

# 802.11n (HT40)

## CH 3

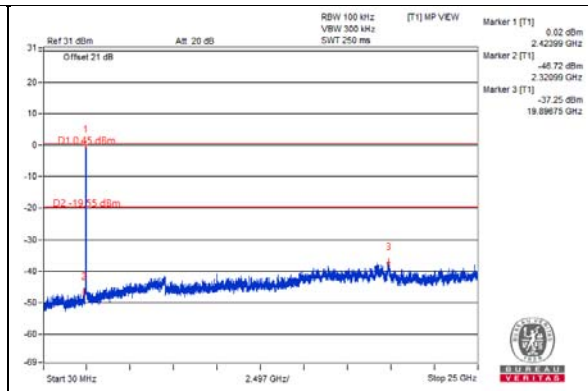
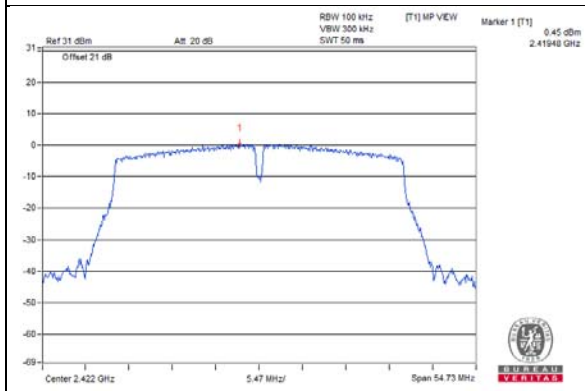

## CH 6

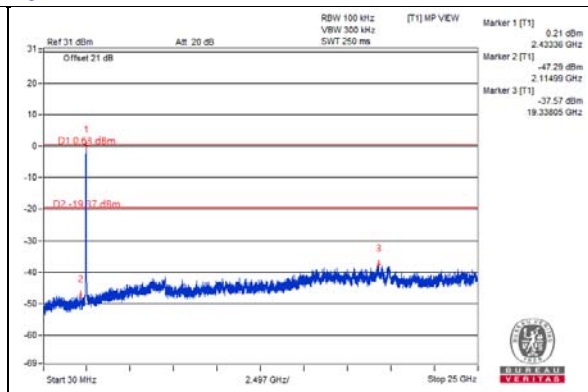
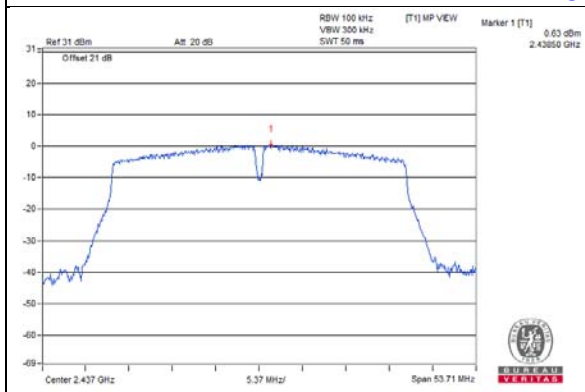

## CH 9

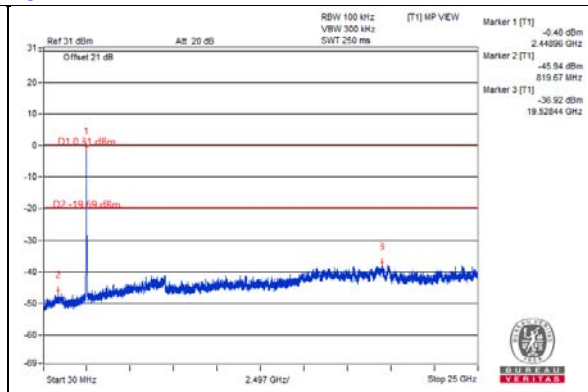
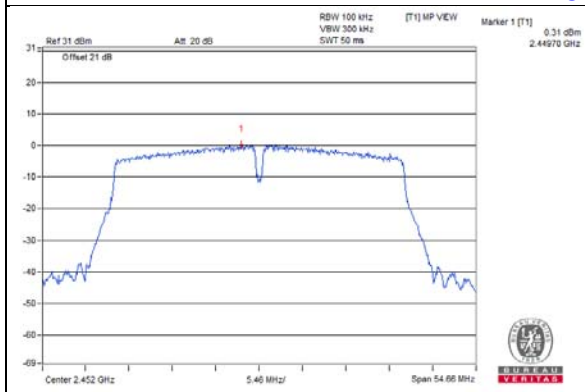

## CH 3 Band edge

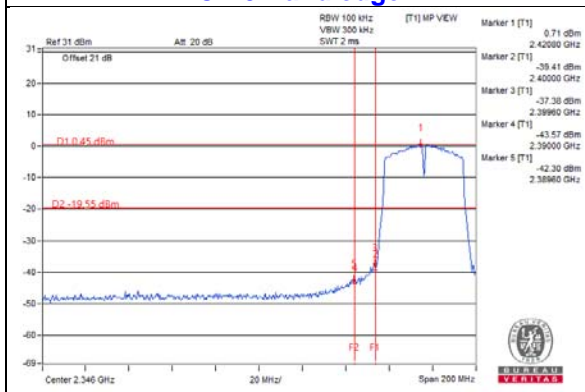

## CH 9 Band edge

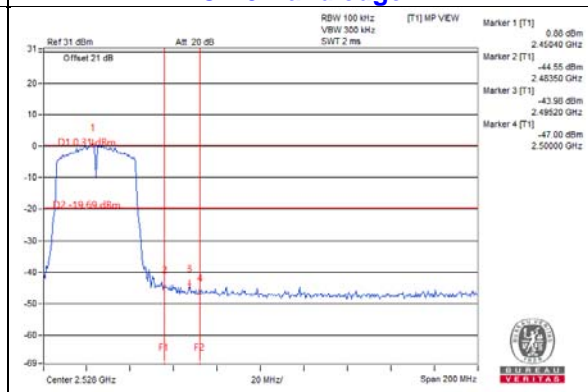

## 5 Pictures of Test Arrangements

Please refer to the attached file (Test Setup Photo).

## Appendix – Information of the Testing Laboratories

We, Bureau Veritas Consumer Products Services (H.K.) Ltd., Taoyuan Branch, were founded in 1988 to provide our best service in EMC, Radio, Telecom and Safety consultation. Our laboratories are FCC recognized accredited test firms and accredited according to ISO/IEC 17025.

If you have any comments, please feel free to contact us at the following:

**Lin Kou EMC/RF Lab**

Tel: 886-2-26052180

Fax: 886-2-26051924

**Hsin Chu EMC/RF/Telecom Lab**

Tel: 886-3-6668565

Fax: 886-3-6668323

**Hwa Ya EMC/RF/Safety Lab**

Tel: 886-3-3183232

Fax: 886-3-3270892

**Email:** [service.adt@tw.bureauveritas.com](mailto:service.adt@tw.bureauveritas.com)

**Web Site:** [www.bureauveritas-adt.com](http://www.bureauveritas-adt.com)

The address and road map of all our labs can be found in our web site also.

--- END ---