



SAR TEST REPORT

for

MODEL NO. 1855
FCC ID: C3K1855
IC ID: 3048A-1855

Test Report No. S-158-FCCISED SAR-1
Issue Date: June 6, 2019

FCC CFR 47 PART 2.1093
ISED RSS-102 Issue 5
IEEE 1528-2013

Prepared by
Microsoft EMC Laboratory
17760 NE 67th Ct,
Redmond WA, 98052, U.S.A.
425-421-9799
sajose@microsoft.com



Test Report Attestation

Microsoft Corporation
Model: 1855

Applicable Standards

Specification	Test Result
FCC CFR 47 PART 2.1093 IEEE 1528-2013 ISED RSS-102 Issue 5	Pass

Microsoft EMC Laboratory attests that the product model identified in this report has been tested to and meets the requirements identified in the above standards. The test results in this report solely pertains to the specific sample tested, under the conditions and operating modes as provided by the customer.

This report shall not be used to claim product certification, approval, or endorsement by A2LA or any agency of any Government. Reproduction, duplication or publication of extracts from this test report is prohibited and requires prior written approval of Microsoft EMC Laboratory.



Written/ Issued By: Zack Gray
SAR Test Lead



Reviewed By: Wei Sun
SAR Test Engineer

Table of Contents

1	Record of Revisions	2
2	Deviations from Standard.....	6
3	Facilities and Accreditation	6
3.1	TEST FACILITY	6
3.2	ACCREDITATIONS	6
3.3	Test Equipment.....	6
4	Highest Reported SAR Values	7
4.1	SAR Limits.....	7
5	Test Equipment List	8
6	Product Description.....	9
6.1	TEST CONFIGURATIONS	9
6.2	ENVIRONMENTAL CONDITIONS.....	10
6.3	EQUIPMENT MODIFICATIONS	10
6.4	EQUIPMENT UNDER TEST	10
6.5	Supported Air Interfaces and Transmission Configurations.....	11
6.5.1	Supported Air Interfaces	11
6.5.2	Transmission Configurations.....	12
7	Test Methodology	13
8	Conducted RF Average Output Power Measurements.....	14
8.1	Bluetooth Conducted Output Power Measurements.....	14
8.2	Bluetooth LE Conducted Output Power Measurements	14
8.3	WLAN Power Measurement Requirements.....	15
8.4	Initial Test Configuration for OFDM Configurations	15
8.5	WLAN 2.4 GHz Conducted Output Power Measurements	16
8.6	WLAN 5 GHz Conducted Output Power Measurements	17
8.6.1	5.2 GHz Conducted Measurements (U-NII-1)	17
8.6.2	5.3 GHz Conducted Measurements (U-NII-2A).....	18
8.6.3	5.6 GHz Conducted Measurements (U-NII-2C).....	19
8.6.4	5.8 GHz Conducted Measurements (U-NII-3) (Continued on next page).....	20
8.6.5	5.8 GHz Conducted Measurements (U-NII-3) Continued	21
9	Test Configurations.....	22
9.1	Test Positions	22

10	SAR Test Procedures.....	23
11	SAR Test Results.....	25
11.1	General SAR Testing Notes.....	25
11.2	WLAN 2.4 GHz SAR Testing Notes.....	25
11.2.1	WLAN 2.4 GHz Chain 0 SAR Test Results.....	26
11.2.2	WLAN 2.4 GHz Chain 1 SAR Test Results.....	26
11.3	WLAN 5 GHz SAR Testing Notes.....	27
11.3.1	WLAN 5.2 GHz SAR Test Results.....	28
11.3.2	WLAN 5.3 GHz Chain 0 SAR Test Results.....	28
11.3.3	WLAN 5.3 GHz Chain 1 SAR Test Results.....	28
11.3.4	WLAN 5.6 GHz Chain 0 SAR Test Results.....	29
11.3.5	WLAN 5.6 GHz Chain 1 SAR Test Results.....	29
11.3.6	WLAN 5.8 GHz Chain 0 SAR Test Results.....	29
11.3.7	WLAN 5.8 GHz Chain 1 SAR Test Results.....	29
11.4	Bluetooth SAR Test Results.....	30
12	Repeated SAR Measurements.....	31
12.1	SAR Variability Repeat Measurements.....	31
13	Simultaneous Transmission Evaluation.....	32
13.1	Important Standalone SAR values for Simultaneous Transmission Evaluation.....	33
13.2	Simultaneous Transmission Evaluation Results.....	34
14	SAR System Verification.....	35
14.1	SAR System Verification Results – Flat Phantom.....	36
14.2	Additional System Verifications – Head Stand Phantom.....	37
14.3	System Verification Results – Head Stand Phantom.....	40
14.4	System Verification Summary.....	40
15	Tissue-Simulating Liquid Verification.....	41
15.1	Tissue-Simulating Liquid Ingredients and Maintenance.....	42
15.2	Tissue-Simulating Liquid Measurements.....	43
16	System Specification.....	44
16.1	SPEAG DASY6 SYSTEM.....	44
17	Measurement Uncertainty.....	45
18	Appendices.....	47

2 Deviations from Standard

Explained in Section 14.2.

3 Facilities and Accreditation

3.1 TEST FACILITY

All test facilities used to collect the test data are located at Microsoft EMC Laboratory: 17760 NE 67th Ct, Redmond, WA, 98052, USA.

3.2 ACCREDITATIONS

The lab is established and follows procedures as outlined in IEC/ISO 17025 and A2LA accreditation requirements.

A2LA Accredited Testing Certificate Number: 3472.01

Expiration Date: Aug 31, 2019

3.3 Test Equipment

The site and related equipment are constructed in conformance with the requirements of IEEE 1528-2013 and other equivalent applicable standards.

The calibrations of the measuring instruments, including any accessories that may affect such calibration, are checked frequently to assure their accuracy. Adjustments are made and correction factors are applied in accordance with instructions contained in the user manual for the measuring equipment.

4 Highest Reported SAR Values

Exposure Condition	Equipment Class	Mode of Operation	Test Position	1-g Reported SAR (W/kg)
Head Exposure	DTS	802.11b	Worn	0.56
	NII	802.11ac VHT80	Worn	0.72
	DSS	Bluetooth 1-DH5	Worn	0.25
	DTS	Simultaneous TX	Worn	1.19
	NII	Simultaneous TX	Worn	1.36
	DSS	Simultaneous TX	Worn	1.36

Reported SAR Values are obtained by scaling the measured SAR values up to the maximum allowable output power for each configuration using the following equation:

$$SAR = MEASURED * 10^{\frac{(P_{MAX}-P)}{10}}$$

where

SAR = Reported SAR (W/kg)

MEASURED = Measured SAR (W/kg)

P_{MAX} = Maximum Conducted Average Output Power (dBm)

P = Measured Conducted Average Output Power (dBm)

4.1 SAR Limits

The following are the relevant SAR limits for FCC and ISED based on the recommendations of ANSI C95.1-1992:

Exposure Condition	Limit (W/kg)
Localized Body SAR	1.6 (1-g cube)

5 Test Equipment List

Manufacturer	Description	Model	SN	Identifier	Cal. Due	Cal. Cycle
Agilent	Signal Generator	N5181A	MY50144791	SAR-051	12/13/2019	1 yr
PRANA	Power Amplifier + Directional Coupler	UX15	1305-1354	SAR-046	N/A	N/A
PRANA	Power Amplifier + Directional Coupler	UX15	1305-1355	SAR-055	N/A	N/A
Agilent	Power Meter	1914A	MY50901710	SAR-052	12/21/2019	1 yr
Agilent	Power Sensor	9304A	MY53040024	SAR-064	12/13/2019	1 yr
Agilent	Power Sensor	9304A	MY53040018	SAR-063	12/12/2019	1 yr
Agilent	Network Analyzer	E5071C	MY46316847	SAR-002	12/20/2019	1 yr
SPEAG	Dielectric Probe Kit	DAK-3.5	1042	SAR-143	2/12/2020	1 yr
SPEAG	DASY Data Acquisition Electronics	DAE4	1384	SAR-073	7/17/2019	1 yr
SPEAG	Dosimetric E-Field Probe	EX3DV4	3940	SAR-072	7/20/2019	1 yr
SPEAG	SAR Validation Dipole, 2450 MHz	D2450V2	917	SAR-025	04/09/2020	1 yr
SPEAG	SAR Validation Dipole, 5 GHz	D5GHzV2	1159	SAR-020	04/16/2020	1 yr
SPEAG	Head Stand Phantom	Head Stand V10	1007	N/A	N/A	N/A
SPEAG	SAM Twin Phantom	Twin SAM V5.0	1779	N/A	N/A	N/A
Thomas Scientific	Thermometer	1230N27	181698176	SAR-169	10/29/2019	1 yr
Thomas Scientific	Thermometer	1230N27	181698185	SAR-170	10/29/2019	1 yr
MadgeTech	THP Monitor	PRHTemp2000	N84195	SAR-092	8/14/2019	1 yr

6 Product Description

Company Name:	Microsoft Corporation			
Address:	One Microsoft Way			
City, State, Zip:	Redmond, WA 98052			
Customer Contact:	Chaitrali Limaye			
Functional Description of the EUT:	Radio transceiver device with IEEE 802.11a/b/g/n/ac MIMO radio supporting 20/40/80MHz bandwidths, Bluetooth 5.0			
RF Exposure Conditions:	Body Exposure			
Model:	1855			
FCC ID:	C3K1855			
IC ID:	3048A-1855			
Radio Descriptions:	WLAN Main 2.4 GHz: 802.11b/g/n 20 / 40 MHz BW's WLAN Main 5 GHz: 802.11a/n/ac 20 / 40 / 80 MHz BW's Bluetooth™ (Basic and Enhanced Data Rates) / Bluetooth LE 5.0			
Frequency Range of Operation:	WLAN Main Radio: (MIMO 2TX)	2412 – 2472 MHz		
		5180 – 5825 MHz		
	BT / BTLE:	2402 – 2480 MHz		
Modulations:	WLAN: CCK, BPSK, QPSK, 16-QAM, 64-QAM, 256-QAM Bluetooth: GFSK, $\frac{\pi}{4}$ DQPSK, and 8 DPSK			
Antenna Peak Gains (dBi):	Radio	Band	Chain 0	Chain 1
	WLAN Main	2400 – 2483.5 MHz	3.3	2.7
		5150 – 5250 MHz	4.3	5.7
		5250 – 5350 MHz	4.3	6.0
		5470 – 5725 MHz	5.2	6.6
		5725 – 5850 MHz	3.0	6.6
Bluetooth	2400 – 2483.5 MHz	3.9		
Equipment Design State:	Prototype/Production Equivalent			
Equipment Condition:	Good			
Dates of Testing:	05/08/2019 – 05/14/2019			

6.1 TEST CONFIGURATIONS

Radiated and Conducted measurements were performed with test software QRCT4 provided by the chipset manufacturer, to program the EUT in continuous transmit mode.

6.2 ENVIRONMENTAL CONDITIONS

Ambient air temperature of the test site was within the range of 18 °C to 25 °C. Testing conditions were within tolerance and any deviations required from the EUT are reported.

6.3 EQUIPMENT MODIFICATIONS

No modifications were made during testing.

6.4 EQUIPMENT UNDER TEST

Model Number	Testing	Serial Number	SW Version	FW Version
1855	SAR	900217290956	Windows 10	18342.1006
1855	SAR	900338591056	Windows 10	18342.1006
1855	Conducted	E35 MFUS-007	Windows 10	18342.1006

6.5 Supported Air Interfaces and Transmission Configurations

The EUT has three antennas which support the following air interfaces and transmission configurations. The antennas are labeled as Chain 0 and Chain 1 for 802.11 WLAN, and the third is dedicated for Bluetooth operation.

6.5.1 Supported Air Interfaces

Band	Air Interface	BW (MHz)		
		20	40	80
WLAN 2.4 GHz	802.11b	X		
	802.11g	X		
	802.11n	X	X	
WLAN 5 GHz	802.11a	X		
	802.11n	X	X	
	802.11ac	X	X	X
2.4 GHz	Bluetooth	NA		
	BTLE	NA		

6.5.2 Transmission Configurations

WLAN Chain 0	WLAN Chain 1	Bluetooth Antenna
WLAN 2.4 GHz		
	WLAN 2.4 GHz	
WLAN 5 GHz		
	WLAN 5 GHz	
WLAN 2.4 GHz	WLAN 2.4 GHz	
WLAN 5 GHz	WLAN 5 GHz	
WLAN 2.4 GHz	WLAN 5 GHz	
		Bluetooth
WLAN 2.4 GHz		Bluetooth
	WLAN 2.4 GHz	Bluetooth
WLAN 5 GHz		Bluetooth
	WLAN 5 GHz	Bluetooth
WLAN 2.4 GHz	WLAN 2.4 GHz	Bluetooth
WLAN 5 GHz	WLAN 5 GHz	Bluetooth
WLAN 2.4 GHz	WLAN 5 GHz	Bluetooth

The device supports WLAN dual-band simultaneous transmission (DBS mode) where it can transmit on the 2.4 GHz and 5 GHz bands at the same time. However, the only supported DBS mode is where Chain 0 transmits in the 2.4 GHz band while Chain 1 transmits in the 5 GHz band, as shown in the table above.

7 Test Methodology

Test setup and procedure are performed according to **IEEE 1528-2013 Recommended Practice for Determining the Peak Spatial-Average Specific Absorption Rate (SAR) in the Human Head from Wireless Communication Devices: Measurement Techniques**.

In addition, the following publications were used as guidance-

- 447498 D01 General RF Exposure Guidance v06
- 865664 D01 SAR Measurement 100 MHz to 6 GHz v01r04
- 865664 D02 RF Exposure Reporting v01r02
- 248227 D01 802.11Wi-Fi SAR v02r02
- RSS-102 – RF (Radio Frequency) Exposure Compliance of Radiocommunication Apparatus, Issue 5 March 2015

8 Conducted RF Average Output Power Measurements

Bluetooth and WLAN output power measurements are made with the DUT connected to the power sensor of a broadband power meter.

8.1 Bluetooth Conducted Output Power Measurements

Channel	Frequency (MHz)	Conducted Average Output Power (dBm)			
		Modulation			Maximum Target Power (GFSK)
		GFSK	$\pi/4$ -DPSK	8DPSK	
0	2402	11.0	6.97	7.8	13.0
39	2440	11.14	7.2	8.05	
78	2480	11.34	7.32	8.15	

8.2 Bluetooth LE Conducted Output Power Measurements

Channel	Frequency (MHz)	Conducted Average Output Power (dBm)	
		Measured	Maximum Target Power
0	2402	-	6.0
19	2440	-	
39	2480	-	

Bluetooth SAR was measured in GFSK / 1-DH5 mode where the measured duty factor is 76.88%. See plot below.

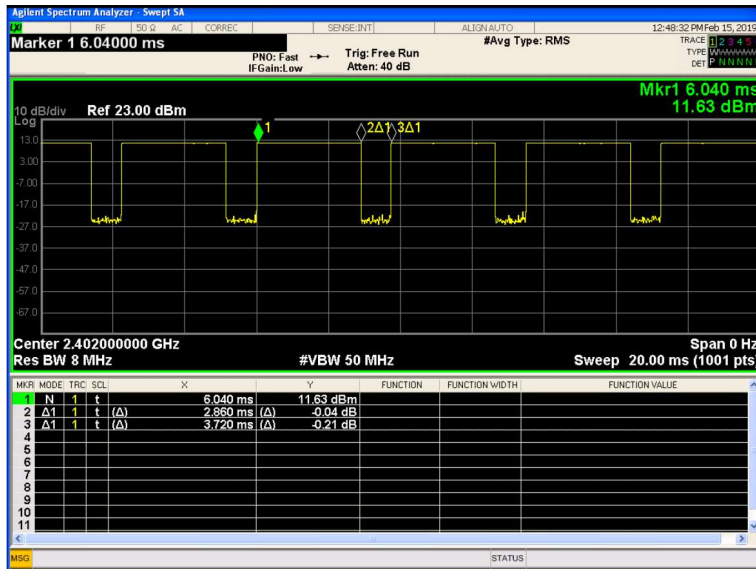

Bluetooth GFSK / 1-DH5 Duty Factor Plot

8.3 WLAN Power Measurement Requirements

According to **KDB 248227 v02r02 Section 4**, maximum output power must be measured according to the default power measurement procedures below. When SAR measurement is required, power measurement is also required to confirm output power settings and to determine reported SAR. Additional power measurements may be necessary to determine SAR test reduction for test channels in a transmission mode. If the required power measurement is not included in the default configuration, it is typically measured immediately before and/or after the SAR measurement. Otherwise, when power measurement is not required for a transmission mode, the maximum output power and tune-up tolerance specified for production units can generally be used to determine SAR test exclusion and reduction.

The default power measurement procedures are:

- 1) Power must be measured at each transmit antenna port according to the DSSS and OFDM transmission configuration in each standalone and aggregated frequency band.
- 2) Power measurement is required for the transmission mode configuration with the highest maximum output power specified for production units.
 - a) When the same higher maximum output power specification applies to multiple transmission modes, the largest channel bandwidth configuration with the lowest order modulation and lowest data rate is measured.
 - b) When the same highest maximum output power is specified for multiple largest channel bandwidth configurations with the same lowest order modulation or lowest order modulation and lowest data rate, power measurement is required for all equivalent 802.11 configurations with the same maximum output power.
- 3) For each transmission mode configuration, power must be measured for the highest and lowest channels; and at the mid-band channel(s) when there are at least 3 channels. For configurations with multiple mid-band channels, due to an even number of channels, both channels should be measured.

8.4 Initial Test Configuration for OFDM Configurations

*The Initial Test Configuration was chosen according to KDB 248227 v02r02 Section 5.3 from the mode with the highest maximum output power including tune-up tolerances, the highest channel bandwidth among those modes, the lowest order modulation, and the lowest data rate. The channel with the highest output power in that mode is chosen as the initial test channel. If multiple test channels have the same measured maximum output power, the channel chosen for SAR measurement is chosen by the following (applicable to subsequent test configuration as well).

- 1) The channel closest to mid-band frequency is selected for SAR measurement.
- 2) For channels with equal separation from mid-band frequency, for example, high and low channels or two mid-band channels, the higher frequency (number) channel is selected for SAR measurement.

8.5 WLAN 2.4 GHz Conducted Output Power Measurements

Mode	Chann.	Freq. (MHz)	Maximum Conducted Average Output Power (dBm)							
			SISO (1 TX)				MIMO (2 TX)			
			Chain 0		Chain 1		Chain 0		Chain 1	
			Meas.	Max	Meas.	Max	Meas.	Max	Meas.	Max
802.11b 1Mbps	1	2412	17.22	17.5	17.2	17.5	-	17.5	-	17.5
	6	2437	17.45	17.5	17.25	17.5	-	17.5	-	17.5
	11	2462	17.35	17.5	17.4	17.5	-	17.5	-	17.5
	12	2467	-	17.5	-	17.5	-	17.5	-	17.5
	13	2472	-	17.5	-	17.5	-	17.5	-	17.5
802.11g 6Mbps	1	2412	-	17.5	-	17.5	-	17.5	-	17.5
	6	2437	-	17.5	-	17.5	-	17.5	-	17.5
	10	2457	-	17.5	-	17.5	-	17.5	-	17.5
	11	2462	-	17.0	-	17.0	-	17.0	-	17.0
	12	2467	-	15.0	-	15.0	-	15.0	-	15.0
	13	2472	-	-4.0	-	-4.0	-	-4.0	-	-4.0
802.11n HT20 MCS0	1	2412	-	15.0	-	15.0	-	15.0	-	15.0
	2	2417	-	17.5	-	17.5	-	17.5	-	17.5
	6	2437	-	17.5	-	17.5	-	17.5	-	17.5
	10	2457	-	17.5	-	17.5	-	17.5	-	17.5
	11	2462	-	16.0	-	16.0	-	16.0	-	16.0
	12	2467	-	14.0	-	14.0	-	14.0	-	14.0
	13	2472	-	-4.0	-	-4.0	-	-4.0	-	-4.0
802.11n HT40 MCS0	3	2422	-	13.0	-	13.0	-	13.0	-	13.0
	6	2437	-	15.5	-	15.5	-	15.5	-	15.5
	9	2452	-	14.5	-	14.5	-	14.5	-	14.5
	10	2457	-	13.5	-	13.5	-	13.5	-	13.5
	11	2462	-	7.0	-	7.0	-	7.0	-	7.0

Power measurements not listed are not required under the rules of **KDB 248227 v02r02 Section 4**.

For 802.11b, since channels 12 and 13 do not have higher specified maximum output power than the other channels, SAR is evaluated on channels 1, 6, and 11. **KDB 248227 D01 Section 3.1**

OFDM power measurements were not made since SAR testing is excluded for these modes in this case by **KDB 248227 v02r02 Section 5.2.2**. See the section on WLAN 2.4 GHz SAR results in this report for further details.

Only SISO power measurements were made since MIMO modes have the same declared maximum output power and all SAR measurements were made in SISO operation. Simultaneous emissions are evaluated in Section 13.

8.6 WLAN 5 GHz Conducted Output Power Measurements

8.6.1 5.2 GHz Conducted Measurements (U-NII-1)

Mode	Chann.	Freq. (MHz)	Maximum Conducted Average Output Power (dBm)							
			SISO (1 TX)				MIMO (2 TX)			
			Chain 0		Chain 1		Chain 0		Chain 1	
			Meas.	Max	Meas.	Max	Meas.	Max	Meas.	Max
802.11a 6Mbps	36	5180	-	10.0	-	10.0	-	10.0	-	10.0
	40	5200	-	10.0	-	10.0	-	10.0	-	10.0
	44	5220	-	10.0	-	10.0	-	10.0	-	10.0
	48	5240	-	10.0	-	10.0	-	10.0	-	10.0
802.11n HT20 MCS0	36	5180	-	10.0	-	10.0	-	10.0	-	10.0
	40	5200	-	10.0	-	10.0	-	10.0	-	10.0
	44	5220	-	10.0	-	10.0	-	10.0	-	10.0
	48	5240	-	10.0	-	10.0	-	10.0	-	10.0
802.11n HT40 MCS0	38	5190	-	13.0	-	13.0	-	13.0	-	13.0
	46	5230	-	13.0	-	13.0	-	13.0	-	13.0
802.11ac VHT20 MCS0	36	5180	-	10.0	-	10.0	-	10.0	-	10.0
	40	5200	-	10.0	-	10.0	-	10.0	-	10.0
	44	5220	-	10.0	-	10.0	-	10.0	-	10.0
	48	5240	-	10.0	-	10.0	-	10.0	-	10.0
802.11ac VHT40 MCS0	38	5190	-	13.0	-	13.0	-	13.0	-	13.0
	46	5230	-	13.0	-	13.0	-	13.0	-	13.0
802.11ac VHT80 MCS0	42	5210	-	14.0	-	14.0	-	14.0	-	14.0

Conducted Power Measurements were not performed in the U-NII-1 band since SAR testing is excluded for it in this case by **KDB 248227 v02r02 Section 5.3.1**. See the later section on WLAN 5 GHz SAR Testing Notes for details.

Only SISO power measurements were made since MIMO modes have the same declared maximum output power and all SAR measurements were made in SISO operation. Simultaneous emissions are evaluated in Section 13.

8.6.2 5.3 GHz Conducted Measurements (U-NII-2A)

Mode	Chann.	Freq. (MHz)	Maximum Conducted Average Output Power (dBm)							
			SISO (1 TX)				MIMO (2 TX)			
			Chain 0		Chain 1		Chain 0		Chain 1	
			Meas.	Max	Meas.	Max	Meas.	Max	Meas.	Max
802.11a 6Mbps	52	5260	-	17.0	-	17.0	-	17.0	-	17.0
	56	5280	-	17.0	-	17.0	-	17.0	-	17.0
	60	5300	-	17.0	-	17.0	-	17.0	-	17.0
	64	5320	-	17.0	-	17.0	-	17.0	-	17.0
802.11n HT20 MCS0	52	5260	-	17.0	-	17.0	-	17.0	-	17.0
	56	5280	-	17.0	-	17.0	-	17.0	-	17.0
	60	5300	-	17.0	-	17.0	-	17.0	-	17.0
	64	5320	-	17.0	-	17.0	-	17.0	-	17.0
802.11n HT40 MCS0	54	5270	16.6	17.5	16.62	17.5	-	17.5	-	17.5
	62	5310	11.32	13.0	11.33	13.0	-	13.0	-	13.0
802.11ac VHT20 MCS0	52	5260	-	17.0	-	17.0	-	17.0	-	17.0
	56	5280	-	17.0	-	17.0	-	17.0	-	17.0
	60	5300	-	17.0	-	17.0	-	17.0	-	17.0
	64	5320	-	17.0	-	17.0	-	17.0	-	17.0
802.11ac VHT40 MCS0	54	5270	16.55	17.5	16.6	17.5	-	17.5	-	17.5
	62	5310	11.31	13.0	11.32	13.0	-	13.0	-	13.0
802.11ac VHT80 MCS0	56	5290	-	11.0	-	11.0	-	11.0	-	11.0

Power measurements not listed are not required under the rules of **KDB 248227 v02r02**

Section 4. See the later section on WLAN 5 GHz SAR Testing Notes for details.

Only SISO power measurements were made since MIMO modes have the same declared maximum output power and all SAR measurements were made in SISO operation.

Simultaneous emissions are evaluated in Section 13.

8.6.3 5.6 GHz Conducted Measurements (U-NII-2C)

Mode	Chann.	Freq. (MHz)	Maximum Conducted Average Output Power (dBm)							
			SISO (1 TX)				MIMO (2 TX)			
			Chain 0		Chain 1		Chain 0		Chain 1	
			Meas.	Max	Meas.	Max	Meas.	Max	Meas.	Max
802.11a 6Mbps	100	5500	-	16.0	-	16.0	-	16.0	-	16.0
	104	5520	-	16.0	-	16.0	-	16.0	-	16.0
	108	5540	-	16.0	-	16.0	-	16.0	-	16.0
	112	5560	-	16.0	-	16.0	-	16.0	-	16.0
	116	5580	-	16.0	-	16.0	-	16.0	-	16.0
	120	5600	-	16.0	-	16.0	-	16.0	-	16.0
	124	5620	-	16.0	-	16.0	-	16.0	-	16.0
	128	5640	-	16.0	-	16.0	-	16.0	-	16.0
802.11n HT20 MCS0	100	5500	-	16.0	-	16.0	-	16.0	-	16.0
	104	5520	-	16.0	-	16.0	-	16.0	-	16.0
	108	5540	-	16.0	-	16.0	-	16.0	-	16.0
	112	5560	-	16.0	-	16.0	-	16.0	-	16.0
	116	5580	-	16.0	-	16.0	-	16.0	-	16.0
	120	5600	-	16.0	-	16.0	-	16.0	-	16.0
	124	5620	-	16.0	-	16.0	-	16.0	-	16.0
	128	5640	-	16.0	-	16.0	-	16.0	-	16.0
802.11n HT40 MCS0	102	5510	-	12.0	-	12.0	-	12.0	-	12.0
	110	5550	-	17.0	-	17.0	-	17.0	-	17.0
	118	5590	-	17.0	-	17.0	-	17.0	-	17.0
	126	5630	-	17.0	-	17.0	-	17.0	-	17.0
802.11ac VHT20 MCS0	100	5500	-	16.0	-	16.0	-	16.0	-	16.0
	104	5520	-	16.0	-	16.0	-	16.0	-	16.0
	108	5540	-	16.0	-	16.0	-	16.0	-	16.0
	112	5560	-	16.0	-	16.0	-	16.0	-	16.0
	116	5580	-	16.0	-	16.0	-	16.0	-	16.0
	120	5600	-	16.0	-	16.0	-	16.0	-	16.0
	124	5620	-	16.0	-	16.0	-	16.0	-	16.0
	128	5640	-	16.0	-	16.0	-	16.0	-	16.0
802.11ac VHT40 MCS0	102	5510	-	12.0	-	12.0	-	12.0	-	12.0
	110	5550	-	17.0	-	17.0	-	17.0	-	17.0
	118	5590	-	17.0	-	17.0	-	17.0	-	17.0
	126	5630	-	17.0	-	17.0	-	17.0	-	17.0
802.11ac VHT80 MCS0	106	5530	12.23	14.0	12.2	14.0	-	14.0	-	14.0
	122	5610	17.0	17.0	16.92	17.0	-	17.0	-	17.0

Power measurements not listed are not required under the rules of **KDB 248227 v02r02 Section 4**. See the later section on WLAN 5 GHz SAR Testing Notes for details.

Only SISO power measurements were made since MIMO modes have the same declared maximum output power and all SAR measurements were made in SISO operation. Simultaneous emissions are evaluated in Section 13.

8.6.4 5.8 GHz Conducted Measurements (U-NII-3) (Continued on next page)

Mode	Chann.	Freq. (MHz)	Maximum Conducted Average Output Power (dBm)							
			SISO (1 TX)				MIMO (2 TX)			
			Chain 0		Chain 1		Chain 0		Chain 1	
			Meas.	Max	Meas.	Max	Meas.	Max	Meas.	Max
802.11a 6Mbps	132	5660	-	16.0	-	16.0	-	16.0	-	16.0
	136	5680	-	16.0	-	16.0	-	16.0	-	16.0
	140	5700	-	15.0	-	15.0	-	15.0	-	15.0
	144	5720	-	17.0	-	17.0	-	17.0	-	17.0
	149	5745	-	17.0	-	17.0	-	17.0	-	17.0
	153	5765	-	17.0	-	17.0	-	17.0	-	17.0
	157	5785	-	17.0	-	17.0	-	17.0	-	17.0
	161	5805	-	17.0	-	17.0	-	17.0	-	17.0
	165	5825	-	17.0	-	17.0	-	17.0	-	17.0
802.11n HT20 MCS0	132	5660	-	16.0	-	16.0	-	16.0	-	16.0
	136	5680	-	16.0	-	16.0	-	16.0	-	16.0
	140	5700	-	15.0	-	15.0	-	15.0	-	15.0
	144	5720	-	17.0	-	17.0	-	17.0	-	17.0
	149	5745	-	17.0	-	17.0	-	17.0	-	17.0
	153	5765	-	17.0	-	17.0	-	17.0	-	17.0
	157	5785	-	17.0	-	17.0	-	17.0	-	17.0
	161	5805	-	17.0	-	17.0	-	17.0	-	17.0
	165	5825	-	17.0	-	17.0	-	17.0	-	17.0
802.11n HT40 MCS0	134	5670	-	17.0	-	17.0	-	17.0	-	17.0
	142	5710	-	17.0	-	17.0	-	17.0	-	17.0
	151	5755	-	17.0	-	17.0	-	17.0	-	17.0
	159	5795	-	17.0	-	17.0	-	17.0	-	17.0

Power measurements not listed are not required under the rules of **KDB 248227 v02r02**

Section 4. See the later section on WLAN 5 GHz SAR Testing Notes for details.

Only SISO power measurements were made since MIMO modes have the same declared maximum output power and all SAR measurements were made in SISO operation. Simultaneous emissions are evaluated in Section 13.

8.6.5 5.8 GHz Conducted Measurements (U-NII-3) Continued

Mode	Chann.	Freq. (MHz)	Maximum Conducted Average Output Power (dBm)							
			SISO (1 TX)				MIMO (2 TX)			
			Chain 0		Chain 1		Chain 0		Chain 1	
			Meas.	Max	Meas.	Max	Meas.	Max	Meas.	Max
802.11ac VHT20 MCS0	132	5660	-	16.0	-	16.0	-	16.0	-	16.0
	136	5680	-	16.0	-	16.0	-	16.0	-	16.0
	140	5700	-	15.0	-	15.0	-	15.0	-	15.0
	144	5720	-	17.0	-	17.0	-	17.0	-	17.0
	149	5745	-	17.0	-	17.0	-	17.0	-	17.0
	153	5765	-	17.0	-	17.0	-	17.0	-	17.0
	157	5785	-	17.0	-	17.0	-	17.0	-	17.0
	161	5805	-	17.0	-	17.0	-	17.0	-	17.0
802.11ac VHT40 MCS0	134	5670	-	17.0	-	17.0	-	17.0	-	17.0
	142	5710	-	17.0	-	17.0	-	17.0	-	17.0
	151	5755	-	17.0	-	17.0	-	17.0	-	17.0
	159	5795	-	17.0	-	17.0	-	17.0	-	17.0
802.11ac VHT80 MCS0	138	5690	16.72	17.0	16.96	17.0	-	17.0	-	17.0
	155	5775	17.0	17.0	17.0	17.0	-	17.0	-	17.0

Power measurements not listed are not required under the rules of **KDB 248227 v02r02**

Section 4. See the later section on WLAN 5 GHz SAR Testing Notes for details.

Only SISO power measurements were made since MIMO modes have the same declared maximum output power and all SAR measurements were made in SISO operation.

Simultaneous emissions are evaluated in Section 13.

9 Test Configurations

9.1 Test Positions

The device was mounted on the Head Stand Phantom as it is intended to be worn, as agreed on with the FCC through KDB Inquiry.

Exposure Condition	Phantom Used	DUT Test Position	Test Setup Photo (See Appendix)
Head	Head Stand	Worn	Photo 1 Photo 2 Photo 3

10 SAR Test Procedures

The SAR Evaluation was performed in the following steps:

- **Power Reference Measurement.**

The Power Measurement and Power Drift Measurements are for monitoring the power drift of the device under test. The minimum distance of probe sensors to surface determines the closest measurement point to phantom surface. The minimum distance of probe sensors to surface is set to 2mm for the EX3DV4 probe as recommended by SPEAG. The Power Reference Measurement is taken at a point close to the antenna whose output is being measured in order to maximize SNR, thus minimizing drift error.

- **Area Scan**

The Area Scan is used as a fast scan in two dimensions to find the areas of high field values (or hot spots), before doing a fine measurement around the hotspot. The sophisticated interpolation routines implemented in DASYS5 software can find the maximum locations even in relatively coarse grids. When an Area Scan has measured all reachable points, it computes the field maxima found and lists all maxima found in the scan area within a certain range of the global maximum. A 2 dB range is required by IEEE STD 1528. Zoom scans need only be performed on all secondary maxima within this range when the absolute maximum found is under 2 dB less than the SAR limit in question (i.e., less than 1 W/kg for the 1.6 W/kg SAR limit). Otherwise, the zoom scan is only performed at the highest maxima found in the area scan. The exception to this is in MIMO configurations where at least one zoom scan should be measured per transmit antenna.

The following x-y grid spacings for the given transmitter frequency ranges are used for area scans in accordance with FCC KDB 865664 D01 SAR Measurement 100 MHz to 6 GHz:

700 MHz – 2 GHz: ≤ 15 mm

2 GHz – 4 GHz: ≤ 12 mm

4 GHz – 6 GHz: ≤ 10 mm

- **Zoom Scan**

Zoom Scans are used to assess the peak spatial SAR values within a cubic averaging volume containing 1g or 10g of simulated tissue. When the measurement is done, the Zoom Scan evaluates the averaged SAR for 1g and 10g and displays these values next to the job's label. The sides of the zoom scan cube should be parallel to the edges of the EUT when possible. The dimensions of a Zoom Scan and spacing between measurement points vary by frequency according to FCC KDB 865664 D01 SAR Measurement 100 MHz to 6 GHz, shown in Table 2 below:

Table 2: Zoom Scan Dimensions

Transmitter Frequency Range	Cube Dimensions	x-y coordinate spatial resolution	z coordinate spatial resolution
700 MHz – 2 GHz	≥ 30 mm	≤ 8 mm	≤ 5 mm
2 GHz – 3 GHz	≥ 28 mm	≤ 5 mm, *≤ 8 mm	≤ 4 mm
3 – 4 GHz	≥ 25 mm	≤ 5 mm, *≤ 7 mm	≤ 3 mm
4 – 6 GHz	≥ 22 mm	≤ 4 mm, *≤ 5 mm	≤ 2 mm

*optional x-y coordinate spatial resolution when Area Scan SAR ≤ 87.5% of applicable SAR limit

○ **Power Drift Measurement**

The Power Drift Measurement measures the field at the same location as the most recent power reference measurement within the same procedure, and with the same settings. The Power Drift Measurement gives the field difference in dB from the reading conducted within the last Power Reference Measurement. The absolute value of this difference must be ≤ 0.21 dB; if it is not, the entire test is repeated or the difference accounted for.

11 SAR Test Results

11.1 General SAR Testing Notes

- From **KDB 447498 D01 General RF Exposure Guidance v06**, the following test channel reduction was applied to each test position of an exposure condition in each wireless mode and configuration. Initial testing for each test position for each band was performed on the middle required test channel (or required test channel with the highest measured power for WLAN modes). Testing of other required channels within the operating mode of a frequency band is not required when the *reported* 1-g or 10-g SAR for the mid-band or highest output power channel is:
 - ≤ 0.8 W/kg or 2.0 W/kg, for 1-g or 10-g respectively, when the transmission band is ≤ 100 MHz
 - ≤ 0.6 W/kg or 1.5 W/kg, for 1-g or 10-g respectively, when the transmission band is between 100 MHz and 200 MHz
- All WLAN measurements were made with the device transmitting at 100% duty cycle.
- Tissue-simulating liquid temperature was maintained within $\pm 2^{\circ}\text{C}$ of that which was measured during liquid verification.

11.2 WLAN 2.4 GHz SAR Testing Notes

(Guidance from KDB 248227 v02r02)

- 802.11b was tested according to the requirements of to **KDB 248227 v02r02 Section 5.2.1 802.11b DSSS SAR Requirements**.
- The highest reported SAR adjusted by the ratio of OFDM to DSSS specified maximum output power is 0.56 W/kg. Since this is ≤ 1.2 W/kg, SAR is not required for 2.4 GHz OFDM modes (**KDB 248227 v02r02 Section 5.2.2.**)

11.2.1 WLAN 2.4 GHz Chain 0 SAR Test Results

Mode	BW (MHz)	Ant	Position	Ch.	Freq. (MHz)	Avg. Pwr. (dBm)	Max. Pwr. (dBm)	Meas. 1g SAR (W/kg)	Reported 1g SAR (W/kg)
802.11b 1 Mbps 1TX	20	0	Worn	1	2412	17.22	17.5	0.359	0.38 (Plot 1)
	20	0	Worn	6	2437	17.45	17.5	0.35	0.35
	20	0	Worn	11	2462	17.35	17.5	0.353	0.37

11.2.2 WLAN 2.4 GHz Chain 1 SAR Test Results

Mode	BW (MHz)	Ant.	Position	Ch.	Freq. (MHz)	Avg. Pwr. (dBm)	Max. Pwr. (dBm)	Meas. 1g SAR (W/kg)	Reported 1g SAR (W/kg)
802.11b 1 Mbps 1TX	20	1	Worn	1	2412	17.2	17.5	0.527	0.56 (Plot 2)
	20	1	Worn	6	2437	17.25	17.5	0.506	0.54
	20	1	Worn	11	2462	17.4	17.5	0.434	0.44

11.3 WLAN 5 GHz SAR Testing Notes

In accordance with **KDB 248227 D01 v02r02 Section 5**:

- When the initial test channel had a reported SAR above 0.8 W/kg, the channel with next highest power was measured for SAR.
- Further channels in the initial test configuration were only measured when subsequent reported SAR values were above 1.2 W/kg.

- U-NII-1:
 - Testing was not required in for the U-NII-1 sub-band since the adjusted SAR from U-NII-2A ≤ 1.2 W/kg (**KDB 248227 v02r02 Section 5.3.1**)
- U-NII-2A:
 - 802.11n HT40 was used as the initial test configuration since it has the highest bandwidth among the modes with the highest declared maximum output power.
 - No subsequent test configuration testing was required since the reported SAR for 802.11n HT40 ≤ 1.2 W/kg.
- U-NII-2C:
 - 802.11ac VHT80 was used as the initial test configuration since it has the highest bandwidth among the modes with the highest declared maximum output power.
 - No subsequent test configuration testing was required since the reported SAR for 802.11ac VHT80 ≤ 1.2 W/kg.
- U-NII-3:
 - 802.11ac VHT80 was used as the initial test configuration since it has the highest bandwidth among the modes with the highest declared maximum output power.
 - No subsequent test configuration testing was required since the reported SAR for 802.11ac VHT80 ≤ 1.2 W/kg.

11.3.1 WLAN 5.2 GHz SAR Test Results

According to **KDB 248227 v02r02 Section 5.3.1**:

When different maximum output power is specified for the U-NII-1 and U-NII-2A bands, begin SAR measurement in the band with the higher specified maximum output power. The highest reported SAR configuration is adjusted by the ratio of lower to higher specified maximum output power for the two bands. When the adjusted SAR is ≤ 1.2 W/kg, SAR is not required for the band with lower maximum output power in that test configuration.

Since the highest reported SAR in U-NII-2A is ≤ 1.2 W/kg, SAR testing was not performed in U-NII-1.

11.3.2 WLAN 5.3 GHz Chain 0 SAR Test Results

Mode	BW (MHz)	Ant.	Position	Ch.	Freq. (MHz)	Avg. Pwr. (dBm)	Max. Pwr. (dBm)	Meas. 1g SAR (W/kg)	Reported 1g SAR (W/kg)
802.11n HT40 MCS0 1TX	40	0	Worn	54	5270	16.6	17.5	0.282	0.35 (Plot 3)

11.3.3 WLAN 5.3 GHz Chain 1 SAR Test Results

Mode	BW (MHz)	Ant.	Position	Ch.	Freq. (MHz)	Avg. Pwr. (dBm)	Max. Pwr. (dBm)	Meas. 1g SAR (W/kg)	Reported 1g SAR (W/kg)
802.11n HT40 MCS0 1TX	40	1	Worn	54	5270	16.62	17.5	0.397	0.49 (Plot 4)

11.3.4 WLAN 5.6 GHz Chain 0 SAR Test Results

Mode	BW (MHz)	Ant.	Position	Ch.	Freq. (MHz)	Avg. Pwr. (dBm)	Max. Pwr. (dBm)	Meas. 1g SAR (W/kg)	Reported 1g SAR (W/kg)
802.11ac VHT80 MCS0 1TX	80	0	Worn	122	5610	17.0	17.0	0.63	0.63 (Plot 5)

11.3.5 WLAN 5.6 GHz Chain 1 SAR Test Results

Mode	BW (MHz)	Ant.	Position	Ch.	Freq. (MHz)	Avg. Pwr. (dBm)	Max. Pwr. (dBm)	Meas. 1g SAR (W/kg)	Reported 1g SAR (W/kg)
802.11ac VHT80 MCS0 1TX	80	1	Worn	122	5610	16.92	17.0	0.473	0.48 (Plot 6)

11.3.6 WLAN 5.8 GHz Chain 0 SAR Test Results

Mode	BW (MHz)	Ant.	Position	Ch.	Freq. (MHz)	Avg. Pwr. (dBm)	Max. Pwr. (dBm)	Meas. 1g SAR (W/kg)	Reported 1g SAR (W/kg)
802.11ac VHT80 MCS0 1TX	80	0	Worn	138	5690	16.72	17.0	0.531	0.57
	80	0	Worn	155	5775	17.0	17.0	0.722	0.72 (Plot 7)

11.3.7 WLAN 5.8 GHz Chain 1 SAR Test Results

Mode	BW (MHz)	Ant.	Position	Ch.	Freq. (MHz)	Avg. Pwr. (dBm)	Max. Pwr. (dBm)	Meas. 1g SAR (W/kg)	Reported 1g SAR (W/kg)
802.11ac VHT80 MCS0 1TX	80	1	Worn	138	5690	16.96	17.0	0.345	0.35 (Plot 8)
	80	1	Worn	155	5775	17.0	17.0	0.237	0.24

11.4 Bluetooth SAR Test Results

Mode	Ant.	Position	Ch.	Freq. (MHz)	Avg. Pwr. (dBm)	Max. Pwr. (dBm)	Meas. 1g SAR (W/kg)	Reported 1g SAR (W/kg)
BT 1-DH5	BT	Worn	78	2480	11.34	13	0.17	0.25 (Plot 9)

12 Repeated SAR Measurements

SAR measurements are repeated according to the rules of **KDB 865664 D01 v01r04 Section 2.8.1 SAR measurement variability**. SAR measurement variability must be assessed for each frequency band. The repeated measurement results below and their reported SAR values are also shown in the previous section, but are again shown here to demonstrate compliance with the requirement.

- 1) Repeated measurement is not required when the original highest measured SAR is < 0.80 W/kg; steps 2) through 4) do not apply.
- 2) When the original highest measured SAR is ≥ 0.80 W/kg, repeat that measurement once.
- 3) Perform a second repeated measurement only if the ratio of largest to smallest SAR for the original and first repeated measurements is > 1.20 or when the original or repeated measurement is ≥ 1.45 W/kg (~ 10% from the 1-g SAR limit).
- 4) Perform a third repeated measurement only if the original, first or second repeated measurement is ≥ 1.5 W/kg and the ratio of largest to smallest SAR for the original, first and second repeated measurements is > 1.20 .

12.1 SAR Variability Repeat Measurements

Repeated SAR measurements were not necessary since there were no measured SAR values greater than 0.8 W/kg.

13 Simultaneous Transmission Evaluation

(KDB 447498 D01 v06) Simultaneous transmission SAR must be considered for all operating configurations and exposure conditions in which separate antennas can transmit signals at the same time. All such simultaneous transmission configurations must be shown to be compliant, which can be done in any of the following three ways:

1. The sum of the highest standalone *Reported* SAR values from each antenna in the configuration is less than the SAR limit.
2. The SAR to peak location separation ratio is ≤ 0.04 . This ratio is calculated as:

$$\frac{(Reported\ SAR^{Antenna1} + Reported\ SAR^{Antenna2})^{1.5}}{Distance\ Between\ Antenna\ 1\ and\ Antenna\ 2\ peak\ SAR\ locations\ in\ mm}$$

3. When neither 1 nor 2 suffice, simultaneous transmission must be measured either by volume scans or multiple zoom scans so that each applicable air interface is tested at all antenna locations in question. The separate scans from the simultaneously transmitting antennas are then summed together point by point to obtain the simultaneous transmission measured SAR value. The reported simultaneous transmission SAR value must be less than the limit.

According to **KDB 248227 D01 WiFi SAR v02r02 Section 6.5**:

The simultaneous transmission SAR test exclusion provisions in KDB publication 447498 can be applied to avoid simultaneous transmission SAR measurement or to reduce the number of tests...To correctly apply simultaneous transmission SAR test exclusion, the reported standalone SAR results must be examined according to all combinations of channel bandwidths, maximum output power, 802.11 transmission modes frequency bands, exposure configurations, and test positions to determine if certain combinations may be considered collectively to apply the SAR test exclusion procedures according to the highest reported SAR for the group.

13.1 Important Standalone SAR values for Simultaneous Transmission Evaluation

The highest standalone values for each antenna and test position combination are listed here. These combinations represent the most conservative simultaneous transmission cases within each band even though some combinations evaluated will not actually transmit at the same time (ie, when the highest case within a band occurs in a different mode or channel for each antenna).

Band	Test Position	Air Interface	Ch.	Freq. (MHz)	Ant.	Peak SAR Location Coordinates (mm from Phantom origin)			Reported SAR (W/kg)
						X	Y	Z	
WLAN 2.4 GHz	Worn	802.11b	1	2412	0		N/A		0.38
	Worn	802.11b	1	2412	1		N/A		0.56
U-NII-1	Testing not required.								
U-NII-2A	Worn	nHT40	54	5270	0		N/A		0.35
	Worn	nHT40	54	5270	1		N/A		0.49
U-NII-2C	Worn	acVHT80	122	5610	0		N/A		0.63
	Worn	acVHT80	122	5610	1		N/A		0.48
U-NII-3	Worn	acVHT80	138	5690	0		N/A		0.57
	Worn	acVHT80	138	5690	1		N/A		0.35
	Worn	acVHT80	155	5775	0		N/A		0.72
	Worn	acVHT80	155	5775	1		N/A		0.24
2.4 GHz	Worn	BT	78	2480	BT		N/A		0.25

13.2 Simultaneous Transmission Evaluation Results

Exposure Condition	Test Position	SAR Value (W/kg)			Peak Location Sep. Distance (mm)	Simultaneous Transmission Evaluation Method Used	Result
		Ch. 0	Ch. 1	BT			
2.4 GHz WLAN (Ch 0) + 2.4 GHz WLAN (Ch 1) + BT							
Head	Worn	0.38	0.56	0.25	N/A	Sum	1.19 W/kg Pass
U-NII-2A WLAN (Ch 0) + U-NII-2A WLAN (Ch 1) + BT							
Head	Worn	0.35	0.49	0.25	N/A	Sum	1.09 W/kg Pass
U-NII-2C WLAN (Ch 0) + U-NII-2C WLAN (Ch 1) + BT							
Head	Worn	0.63	0.48	0.25	N/A	Sum	1.36 W/kg Pass
U-NII-3 WLAN (Ch 0) + U-NII-3 WLAN (Ch 1) + BT							
Head	Worn	0.57	0.35	0.25	N/A	Sum	1.17 W/kg Pass
	Worn	0.72	0.24	0.25	N/A	Sum	1.21 W/kg Pass
DBS Mode - 2.4 GHz WLAN (Ch 0) + U-NII-3 (Ch 1) + BT							
Head	Worn	0.38	0.49	0.25	N/A	Sum	1.12 W/kg Pass

14 SAR System Verification

System Verifications were performed in accordance with **IEEE 1528-2013** and **KDB 865664 D01 v01r04**. Verifications were performed for each frequency band and within the valid range of each probe calibration point required for testing the device. The same SAR probe(s) and tissue-equivalent liquid combinations used with each SAR system for system verification were used for device testing. Verifications were performed before each series of SAR measurements using the same calibration point and tissue-equivalent medium and every three days thereafter when necessary.

The test setup diagram is shown below. A CW signal is created by a signal generator and fed through a power amplifier with directional coupler outputs. The forward output power is adjusted to 20 dBm while the coupled output power is normalized to 0dB for easy monitoring. When the forward power is attached to the dipole, the power is then adjusted if necessary so that the coupled channel again reads 0 dB on the power meter. Tissue-simulating liquid depth in the phantom is maintained to be at least 15 cm for frequencies below 3 GHz and 10 cm for frequencies above 5 GHz.

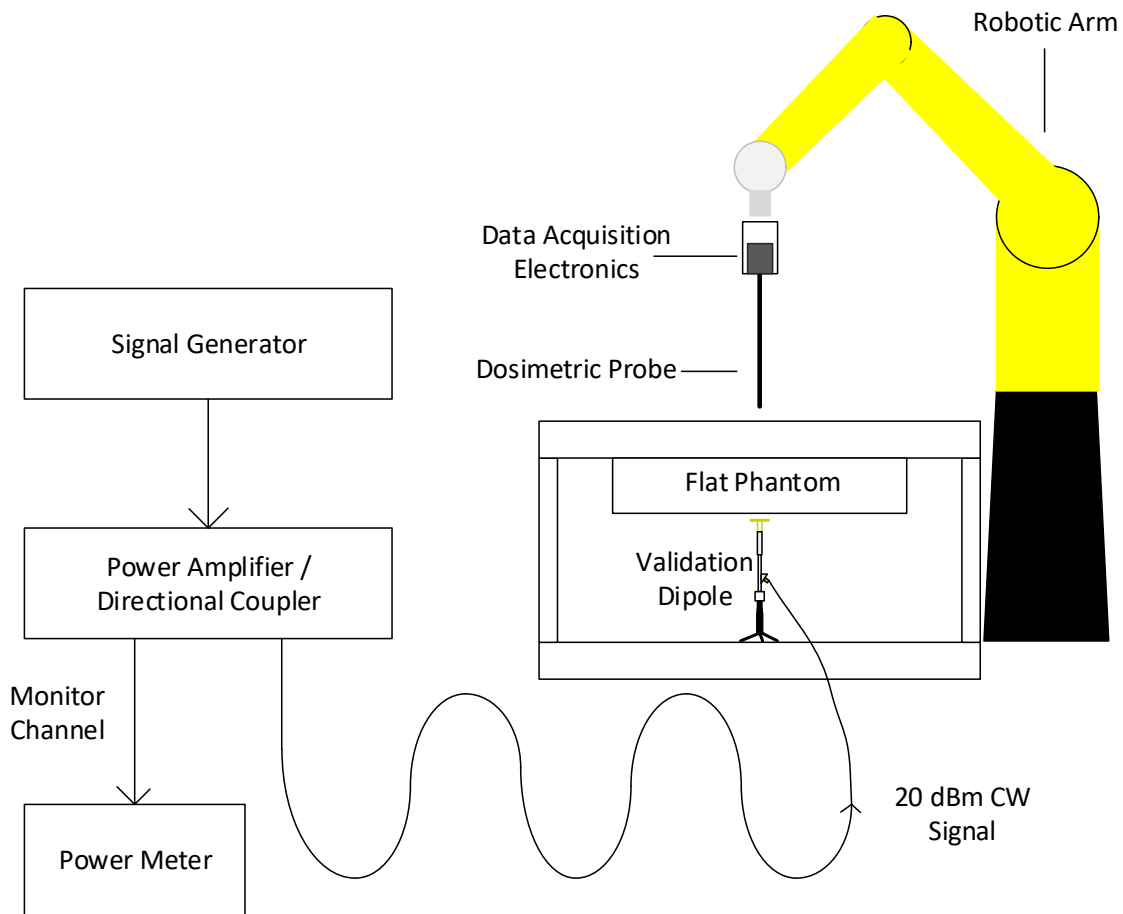

System Verification Setup

14.1 SAR System Verification Results – Flat Phantom

All verifications are performed with a 100 mW (20 dBm) input to the dipole. The resultant measured SAR is normalized to 1 W (30 dBm) for comparison to calibrated dipole targets. All normalized SAR system verification results using the flat phantom were within 10% of the respective dipole target values. System verifications using the flat phantom were performed for every probe calibration point which was used during testing.

Date	Tissue-Sim. Liquid	Probe SN	Dipole	Freq. (MHz)	Meas. 1-g SAR (W/kg)	Norm. 1-g SAR (W/kg)	Dipole Target 1-g SAR (W/kg)	Dev. from Target 1-g SAR (%)
5/11/2019	HSL	3940	2450V2_917	2450	5.21	52.1	51.8	0.58 (Plot 10)
5/8/2019	HSL	3940	5GHzV2_1159	5250	8.23	82.3	79.9	3.00 (Plot 11)
5/8/2019	HSL	3940	5GHzV2_1159	5600	7.91	79.1	81.4	-2.83 (Plot 12)
5/8/2019	HSL	3940	5GHzV2_1159	5750	7.92	79.2	78.8	0.51 (Plot 13)

14.2 Additional System Verifications – Head Stand Phantom

When using DASY6 with the Head Stand Phantom, the angle of the probe relative to the surface normal can exceed the limits set by IEEE 1528-2013. Therefore, additional system verifications were performed using the Head Stand Phantom itself. As recommended by the SAR system manufacturer and confirmed as appropriate through KDB inquiry with the FCC, these additional system checks were performed at one of the points on the SAM phantom defined by the draft standard of IEC 62209-3. These points are shown in the figure below.

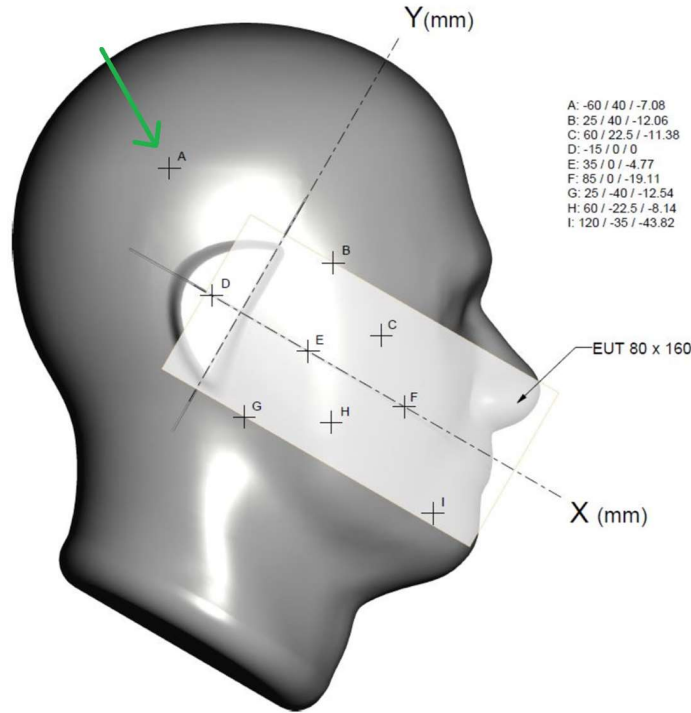

IEC 62209-3 System Check Locations

Point A was chosen as it is the closest point to the portion of the phantom which is utilized for the EUT measurements. Since the dipole calibration certificates do not have target values for use with this phantom, the target values from the IEC 62209-3 draft standard are used, leading to additional uncertainty from the target values used. The recommendation from the system manufacturer, from their application note for use of this phantom, is that the combined dipole target uncertainty + measurement system uncertainty be used as the acceptable deviation from target values. It was confirmed through the KDB inquiry that this would be an acceptable criterion to show a successful system check using the Head Stand Phantom.

The target values vary slightly based on what angle the dipole is oriented in. The three possible dipole arm orientations for which target values are defined are shown below. The dipoles were placed in the orientation defined as 90°.

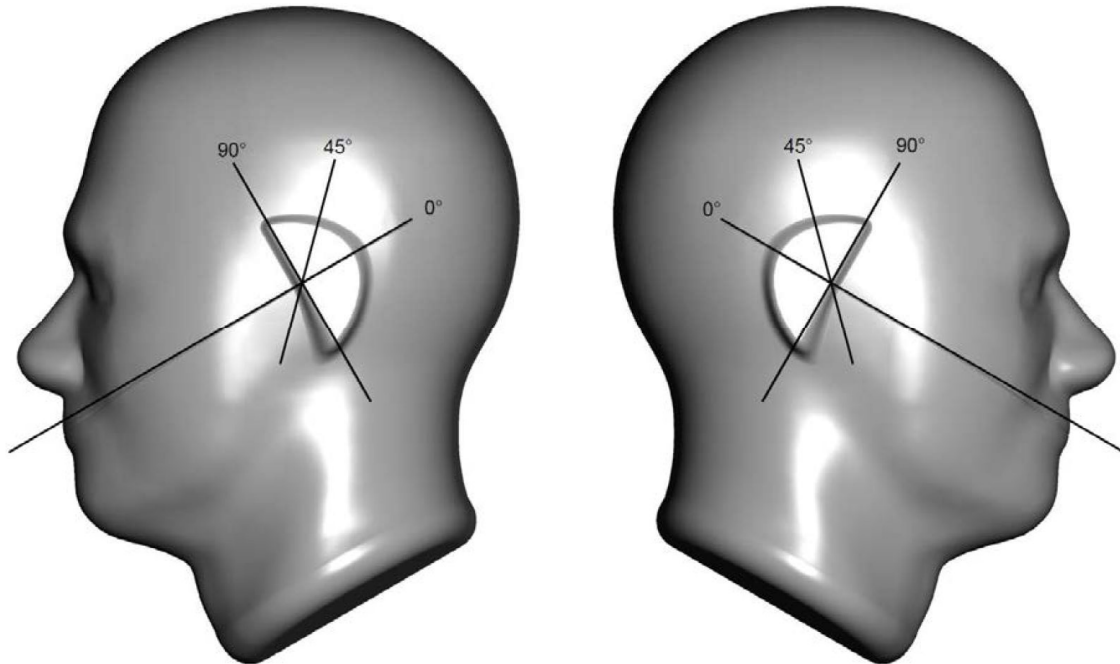

IEC 62209-3 Definition of Rotation Angles for Dipoles



2.4 GHz Dipole Placed at Location A in 90° Orientation (10mm Spacer)



5 GHz Dipole Placed at Location A in 90° Orientation (10mm Spacer)

As per agreement from the FCC KDB Inquiry, the system checks using the Head Stand Phantom are to be performed using one frequency in the 2.4 GHz band and one frequency in the 5 GHz band. The target values from the IEC 62209-3 standard for those two frequencies, 2450 MHz and 5800 MHz, are shown below. Appropriate 1-gram target SAR values for point A with a 90-degree dipole orientation are chosen from here.

Antenna Annex F	f _i [MHz]	P _i [dBm]	Modulation	Loc Deg	d [mm]	SAR 1g,cal	SAR 10g,cal
D2450	2450	20	M1, M3, M6, M12, M14	A/ B/ D/ F 0/ 90	10	A(0/90)=(5.46/5.35); B(0/90)=(5.40/5.38); D(0/90)=(3.39/3.22); F(0/90)=(5.32/5.48)	A(0/90)=(2.46/2.40); B(0/90)=(2.51/2.43); D(0/90)=(1.65/1.60); F(0/90)=(2.40/2.49)
D5000	5800	24	M1, M4, M5, M14	A/ B/ D/ F 0/ 45/ 90	10	A(0/45/90)=(21.1/19.7/20.1); B(0/45/90)=(21.1/21.2/20.4); D(0/45/90)=(15.5/15.7/16.1); F(0/45/90)=(20.8/20.9/20.8)	A(0/45/90)=(5.2/5.1/5.1); B(0/45/90)=(5.4/5.3/5.2); D(0/45/90)=(5.0/5.1/5.3); F(0/45/90)=(5.2/5.2/5.2)

IEC 62209-3 Dipole Target Values

Freq. (MHz)	Point	Orientation	Input Power (dBm)	Target 1-g SAR (W/kg)	Target 1-g SAR Normalized to 30 dBm (W/kg)
2450	A	90	20	5.35	53.5
5800	A	90	24	20.1	80.4

IEC 62209-3 Dipole Target Values Utilized

14.3 System Verification Results – Head Stand Phantom

All verifications are performed with a 100 mW (20 dBm) input to the dipole. The measured and applicable target values from the previous table are then normalized to 30 dBm. The uncertainty of the target values has been defined as 0.4 dB (k=2). The system measurement uncertainty detailed in Section 17 is 1.1 dB (k=2). The combined uncertainty of target values (0.4 dB) and system uncertainty (1.1 dB) is 1.2 dB (k=2). All deviations of the measured SAR from the normalized dipole target values below are within this **1.2 dB** measurement uncertainty, meeting the agreed upon criteria to demonstrate system performance when using the Head Stand Phantom.

Date	Tissue-Sim. Liquid	Probe SN	Dipole	Freq. (MHz)	Meas. 1-g SAR (W/kg)	Norm. 1-g SAR (W/kg)	Dipole Target 1-g SAR (W/kg)	Dev. from Target 1-g SAR (dB)
5/11/2019	HSL	3940	2450V2_917	2450	5.87	58.7	53.5	0.40 (Plot 14)
5/8/2019	HSL	3940	5GHzV2_1159	5800	8.22	82.2	80.4	0.10 (Plot 15)

14.4 System Verification Summary

The system verification results from section 14.1 were obtained using the same liquid which was later put into the Head Stand phantom. Those results demonstrate the system meets the system check criteria from IEEE 1528-2013 and KDB 865664 D01 for all calibration points used in testing of the EUT.

The system check results from section 14.3 using the Head Stand Phantom demonstrate that the system meets the criteria agreed upon through the FCC KDB Inquiry.

Together the results from these two sections demonstrate that the system is properly functioning for all required probe calibration points and that measurements made with the Head Stand Phantom can be expected to give results within system measurement uncertainty criteria.

15 Tissue-Simulating Liquid Verification

(KDB 854664 D01 v01r04 Section 2.4) The tissue dielectric parameters of tissue-equivalent media used for SAR measurements must be characterized within a temperature range of 18°C to 25°C, measured with calibrated instruments and apparatuses, such as network analyzers and temperature probes. The temperature of the tissue-equivalent medium during SAR measurement must also be within 18°C to 25°C and within $\pm 2^\circ\text{C}$ of the temperature when the tissue parameters are characterized. The tissue dielectric measurement system must be calibrated before use. The dielectric parameters must be measured before the tissue-equivalent medium is used in a series of SAR measurements. The parameters should be re-measured after each 3 – 4 days of use; or earlier if the dielectric parameters can become out of tolerance; for example, when the parameters are marginal at the beginning of the measurement series.

The target parameters for the tissue-simulating liquids are obtained from the following table from KDB 865664 D01:

Target Frequency (MHz)	Head		Body	
	ϵ_r	σ (S/m)	ϵ_r	σ (S/m)
150	52.3	0.76	61.9	0.80
300	45.3	0.87	58.2	0.92
450	43.5	0.87	56.7	0.94
835	41.5	0.90	55.2	0.97
900	41.5	0.97	55.0	1.05
915	41.5	0.98	55.0	1.06
1450	40.5	1.20	54.0	1.30
1610	40.3	1.29	53.8	1.40
1800 – 2000	40.0	1.40	53.3	1.52
2450	39.2	1.80	52.7	1.95
3000	38.5	2.40	52.0	2.73
5800	35.3	5.27	48.2	6.00

(ϵ_r = relative permittivity, σ = conductivity and $\rho = 1000 \text{ kg/m}^3$)

15.1 Tissue-Simulating Liquid Ingredients and Maintenance

The Tissue-simulating liquids were manufactured by SPEAG. The following information on the maintenance of

MSL 2450 Ingredients: Water, DGBE

MBBL 3500 – 5800 Ingredients: Water, Mineral Oil, Emulsifiers, Sodium Chloride

DGBE BASED LIQUIDS

DGBE is easily dissolved in water. Given a DGBE-water mixture, mainly water will evaporate, however DGBE will evaporate to a smaller percentage. For the frequency liquids around 2.5 GHz, no NaCl is contained and should therefore not be added for any corrections. Evaporated water can be replaced and will mainly increase the permittivity, and to a small extent the conductivity, typically as follows:

HSLxxxxV2: permittivity 0.8 to 1.0 per % of water, conductivity 0 to 0.1 per % of water

MSLxxxxV2: permittivity 0.8 per % of water, conductivity 0 to 0.01 per % of water

OIL BASED LIQUIDS

Oil based liquids are an emulsion of a complex mixture of ingredients. Their appearance is yellow or brown transparent or slightly opaque / milky in most cases. Some older liquids may show a non-transparent upper zone with a creamy appearance after some time without stirring. Before using or handling the liquid, it must therefore be stirred to become entirely homogeneous. An opaque appearance is possible but will not influence the dielectric parameters if it is homogeneous during the measurement at the probe surface. Evaporated water can be replaced and will increase the permittivity, and to a smaller extent the conductivity.

The **sensitivities to water addition** (% parameter increase per weight% water added) of oil based SPEAG broadband tissue simulating liquids at the frequencies of interest are typically in the following range:

HBBL3500-5800V5 at 3.5 GHz: permittivity 0.79, conductivity 0.14
at 5.5 GHz: permittivity 0.83, conductivity 0.41

MBBL3500-5800V5 at 3.5 GHz: permittivity 0.44, conductivity 0.00
at 5.5 GHz: permittivity 0.48, conductivity 0.18

The **temperature gradients** shall be observed especially during conductivity measurement:

HBBL3500-5800V5 at 3.5 GHz: permittivity -0.07, conductivity -0.43 %/°C
at 5.5 GHz: permittivity -0.23, conductivity -0.96 %/°C

MBBL3500-5800V5 at 3.5 GHz: permittivity -0.35, conductivity -1.14 %/°C
at 5.5 GHz: permittivity -0.08, conductivity -1.52 %/°C

15.2 Tissue-Simulating Liquid Measurements

Date	Tissue-Simulating Liquid	Freq. (MHz)	Rel. Perm. ϵ'_r	Target ϵ'_r	ϵ'_r Dev. %	Cond. σ (S/m)	Target σ (S/m)	σ Dev. %
5/11/2019	HBBL 160212-1 21.6 °C	2400	38.5	39.29	-2.01	1.76	1.76	0.00
		2410	38.5	39.27	-1.96	1.77	1.76	0.31
		2440	38.5	39.22	-1.83	1.79	1.79	0.00
		2450	38.4	39.2	-2.04	1.8	1.80	0.00
		2460	38.4	39.19	-2.01	1.8	1.81	-0.60
		2480	38.4	39.6	-1.95	1.82	1.83	-0.69
5/8/2019	HBBL 160212-1 22.6 °C	5180	36.3	36.01	0.81	4.48	4.63	-3.33
		5200	36.4	35.99	1.15	4.5	4.66	-3.33
		5240	36.3	35.94	1.00	4.55	4.70	-3.11
		5260	36.3	35.92	1.07	4.56	4.72	-3.32
		5300	36.2	35.87	0.92	4.61	4.76	-3.10
		5320	36.2	35.85	0.98	4.63	4.78	-3.10
		5500	35.9	35.64	0.72	4.82	4.96	-2.87
		5580	35.7	35.55	0.42	4.92	5.04	-2.47
		5600	35.7	35.53	0.48	4.94	5.07	-2.47
		5700	35.5	35.41	0.24	5.05	5.17	-2.27
		5745	35.5	35.36	0.39	5.11	5.21	-1.99
		5785	35.4	35.32	0.23	5.16	5.25	-1.80
		5825	35.4	35.27	0.36	5.18	5.30	-2.18

16 System Specification

16.1 SPEAG DASY6 SYSTEM

DASY 6 system performing SAR testing contains the following items, which are illustrated in the figure below.

- 6-axis robot (model: TX90XL) with controller and teach pendant.
- Dosimetric E-field probe.
- Light beam unit which allows automatic “tooling” of the probe.
- The electro-optical converter (EOC) which is mounted on the robot arm.
- The data acquisition electronics (DAE).
- Elliptical Phantom
- Device holder.
- Remote control.
- PC.
- DASY6 software.
- Validation dipole.

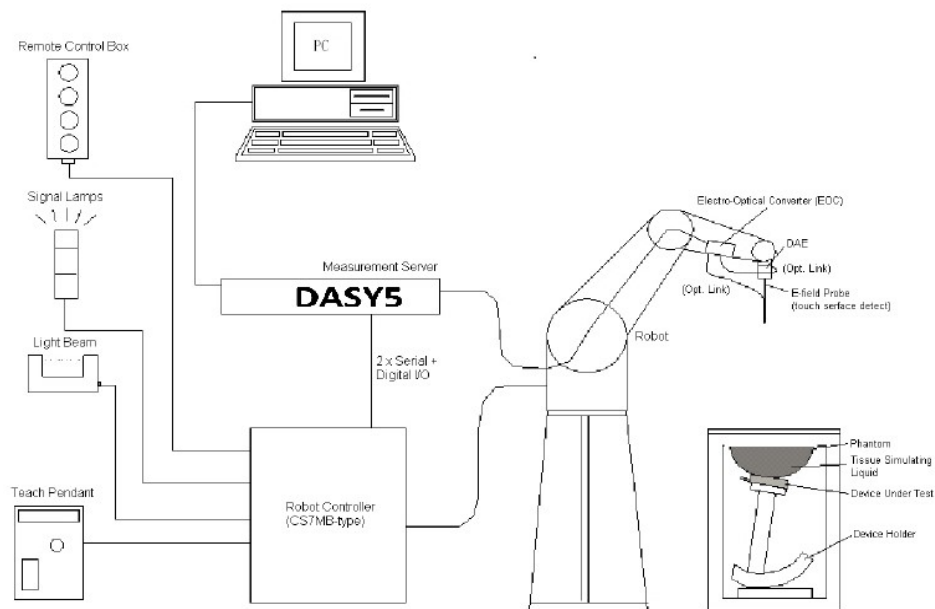

DASY6 System Setup

17 Measurement Uncertainty

DASY6 Uncertainty Budget for Specialized Phantoms (0.3 – 3 GHz range)								
Error Description	Uncert. Value	Prob. Dist.	Div.	(c _i) 1g	(c _i) 10g	Std. Unc. (1g)	Std. Unc. (10g)	(V _j) V _{eff}
Measurement System								
Probe Calibration	±6.0%	Normal	1	1	1	±6.0%	±6.0%	∞
Axial Isotropy	±4.7%	Rectangular	√3	0	0	±0.0%	±0.0%	∞
Hemispherical Isotropy	±9.6%	Rectangular	√3	1	1	±5.5%	±5.5%	∞
Boundary Effects	±0.0%	Rectangular	√3	1	1	±0.0%	±0.0%	∞
Linearity	±4.7%	Rectangular	√3	1	1	±2.7%	±2.7%	∞
System Detection Limits	±1.0%	Rectangular	1	1	1	±0.6%	±0.6%	∞
Modulation Response	±2.4%	Rectangular	√3	1	1	±1.4%	±1.4%	∞
Readout Electronics	±0.3%	Normal	1	1	1	±0.3%	±0.3%	∞
Response Time	±0.8%	Rectangular	√3	1	1	±0.5%	±0.5%	∞
Integration Time	±2.6%	Rectangular	√3	1	1	±1.5%	±1.5%	∞
RF Ambient Noise	±3.0%	Rectangular	√3	1	1	±1.7%	±1.7%	∞
RF Ambient Reflections	±3.0%	Rectangular	√3	1	1	±1.7%	±1.7%	∞
Probe Positioner	±0.02%	Rectangular	√3	1	1	±0.0%	±0.0%	∞
Probe Positioning	±2.9%	Rectangular	√3	1	1	±1.6%	±1.6%	∞
Max. SAR Eval.	±15.0%	Rectangular	√3	1	1	±8.7%	±8.7%	∞
Test Sample Related								
Device Positioning	±2.9%	Normal	1	1	1	±2.9%	±2.9%	145
Device Holder	±3.6%	Normal	1	1	1	±3.6%	±3.6%	5
Power Drift	±5.0%	Rectangular	√3	1	1	±2.9%	±2.9%	∞
Power Scaling ^P	±0%	Rectangular	√3	1	1	±0%	±0%	∞
Phantom and Setup								
Phantom Uncertainty	±6.1%	Rectangular	√3	1	1	±3.5%	±3.5%	∞
SAR Correction	±1.9%	Normal	1	1	0.84	±1.9%	±1.6%	∞
Liquid Conductivity (mea.)	±2.5%	Normal	1	0.78	0.71	±2.0%	±1.8%	∞
Liquid Permittivity (mea.)	±2.5%	Normal	1	0.26	0.26	±0.6%	±0.7%	∞
Temp. unc. – Conductivity	±3.4%	Rectangular	√3	0.78	0.71	±1.5%	±1.4%	∞
Temp. unc. - Permittivity	±0.4%	Rectangular	√3	0.23	0.26	±0.1%	±0.1%	∞
Combined Std. Uncertainty						±14.7%	±14.6%	1329
Expanded Std. Uncertainty						±29.3%	±29.2%	

DASY6 Uncertainty Budget for Specialized Phantoms (3 – 6 GHz range)								
Error Description	Uncert. Value	Prob. Dist.	Div.	(c _i) 1g	(c _i) 10g	Std. Unc. (1g)	Std. Unc. (10g)	(V _i) V _{eff}
Measurement System								
Probe Calibration	±6.55%	Normal	1	1	1	±6.55%	±6.55%	∞
Axial Isotropy	±4.7%	Rectangular	0	0	0	±0.0%	±0.0%	∞
Hemispherical Isotropy	±9.6%	Rectangular	√3	0.7	0.7	±5.5%	±5.5%	∞
Boundary Effects	±0.0%	Rectangular	√3	1	1	±0%	±0%	∞
Linearity	±4.7%	Rectangular	√3	1	1	±2.7%	±2.7%	∞
System Detection Limits	±1.0%	Rectangular	√3	1	1	±0.6%	±0.6%	∞
Modulation Response	±2.4%	Rectangular	√3	1	1	±1.4%	±1.4%	∞
Readout Electronics	±0.3%	Normal	1	1	1	±0.3%	±0.3%	∞
Response Time	±0.8%	Rectangular	√3	1	1	±0.5%	±0.5%	∞
Integration Time	±2.6%	Rectangular	√3	1	1	±1.5%	±1.5%	∞
RF Ambient Noise	±3.0%	Rectangular	√3	1	1	±1.7%	±1.7%	∞
RF Ambient Reflections	±3.0%	Rectangular	√3	1	1	±1.7%	±1.7%	∞
Probe Positioner	±0.04%	Rectangular	√3	1	1	±0.0%	±0.0%	∞
Probe Positioning	±6.7%	Rectangular	√3	1	1	±3.8%	±3.8%	∞
Max. SAR Eval.	±12.0%	Rectangular	√3	1	1	±6.9%	±6.9%	∞
Test Sample Related								
Device Positioning	±2.9%	Normal	1	1	1	±2.9%	±2.9%	145
Device Holder	±3.6%	Normal	1	1	1	±3.6%	±3.6%	5
Power Drift	±5.0%	Rectangular	√3	1	1	±2.9%	±2.9%	∞
Power Scaling ^P	±0%	Rectangular	√3	1	1	±0.0%	±0.0%	∞
Phantom and Setup								
Phantom Uncertainty	±6.6%	Rectangular	√3	1	1	±3.8%	±3.8%	∞
SAR Correction	±1.9%	Normal	1	1	0.84	±1.9%	±1.6%	∞
Liquid Conductivity (mea.)	±2.5%	Normal	1	0.78	0.71	±2.0%	±1.8%	∞
Liquid Permittivity (mea.)	±2.5%	Normal	1	0.23	0.26	±0.6%	±0.7%	∞
Temp. unc. – Conductivity	±3.4%	Rectangular	√3	0.78	0.71	±1.5%	±1.4%	∞
Temp. unc. - Permittivity	±0.4%	Rectangular	√3	0.23	0.26	±0.1%	±0.1%	∞
Combined Std. Uncertainty						±14.5%	±14.4%	1256
Expanded Std. Uncertainty						±28.9%	±28.8%	

18 Appendices

The following are contained in the attached appendices:

- Highest SAR Test and SAR System Verification Plots
- SAR Test Setup Photos
- Calibration Report Documents for:
 - Validation Dipole D2450V2-917_Apr19
 - Validation Dipole D5GHzV2-1159_Apr19
 - Dosimetric Probe EX3-DV4-3940_Apr19

End of Test Report