



SAR TEST REPORT

for

MODEL NO. 1645

Test Report No. S-TR12-FCCSAR-1

Issue Date: 3-16-2015

FCC CFR 47 PART 2.1093

IC RSS-102 Issue 4

IEEE 1528-2013

Prepared by

Microsoft EMC Laboratory

17760 NE 67th Ct,

Redmond WA, 98052, U.S.A.

425-421-9799

sajose@microsoft.com



TESTING CERT #3472.01

Report V2.0

Test Report Attestation

Microsoft Corporation
Model: 1645

Applicable Standards

Specification	Test Result
FCC CFR 47 PART 2.1093 IC RSS-102 Issue 4 IEEE 1528-2013	Pass

Microsoft EMC Laboratory attests that the product model identified in this report has been tested to and meets the requirements identified in the above standards. The test results in this report solely pertains to the specific sample tested, under the conditions and operating modes as provided by the customer. All indications of Pass/Fail in this report are opinions expressed by the Microsoft EMC Laboratory based on interpretations and/or observations of test result on the tested sample only.

This report shall not be used to claim product certification, approval, or endorsement by A2LA or any agency of any Government. Reproduction, duplication or publication of extracts from this test report is prohibited and requires prior written approval of Microsoft EMC Laboratory.



Written By: Zack Gray
SAR Test Lead



Reviewed/ Issued By: Sajay Jose
EMC/RF Compliance Lab Manager

Table of Contents

1	Record of Revisions	2
2	Deviations from Standard.....	7
3	Facilities and Accreditation	7
3.1	TEST FACILITY	7
3.2	ACCREDITATIONS	7
3.3	Test Equipment.....	7
4	Highest Reported SAR Values	8
4.1	SAR Limits	8
5	Test Equipment List	9
6	Product Description.....	10
6.1	TEST CONFIGURATIONS	10
6.2	ENVIRONMENTAL CONDITIONS	10
6.3	EQUIPMENT MODIFICATIONS	10
6.4	EQUIPMENT UNDER TEST	11
6.4.1	Accessory Test Equipment	11
6.5	Supported Air Interfaces and Transmission Configurations.....	12
6.5.1	Supported Air Interfaces	12
6.5.2	Transmission Configurations.....	12
7	Test Methodology	13
8	Conducted RF Average Output Power Measurements.....	14
8.1	Bluetooth Conducted Output Power Measurements.....	14
8.2	Bluetooth LE Conducted Output Power Measurements	14
8.3	WLAN 2.4 GHz Conducted Output Power Measurements	15
8.4	WLAN 5 GHz Conducted Output Power Measurements	16
8.4.1	5.2 GHz Conducted Measurements (U-NII-1)	16
8.4.2	5.3 GHz Conducted Measurements (U-NII-2A)	17
8.4.3	5.6 GHz Conducted Measurements (U-NII-2C).....	18
	5.6 GHz Conducted Measurements (U-NII-2C) Continued.....	19
8.4.4	5.8 GHz Conducted Measurements (U-NII-3)	20
8.5	Power Measurements at Higher Data Rates	21
8.5.1	WLAN 2.4 GHz Conducted Power Measurements at Higher Data Rates.....	21

8.5.2	WLAN 5 GHz Conducted Power Measurements at Higher Data Rates	22
9	Test Configurations	23
9.1	Evaluation of Required Test Configurations	24
9.2	Test Positions	25
9.3	Additional Test Positions with Accessory Attached	25
10	SAR Test Procedures	26
11	SAR Test Results	28
11.1	General SAR Testing Notes	28
11.2	WLAN 2.4 GHz SAR Testing Notes	28
11.3	WLAN 2.4 GHz Main Antenna (Path B) SAR Test Results	29
11.4	WLAN 2.4 GHz Aux. Antenna (Path A) SAR Test Results	29
11.5	WLAN 2.4 GHz SAR Test Results with Type Cover Accessory	30
11.6	WLAN 5 GHz SAR Testing Notes	31
11.7	WLAN 5.2 GHz Main Antenna (Path B) SAR Test Results	32
11.8	WLAN 5.2 GHz Aux. Antenna (Path A) SAR Test Results	32
11.9	WLAN 5.2 GHz SAR Test Results with Type Cover Accessory	33
11.10	WLAN 5.3 GHz Main Antenna (Path B) SAR Test Results	34
11.11	WLAN 5.3 GHz Aux. Antenna (Path A) SAR Test Results	34
11.12	WLAN 5.3 GHz SAR Test Results with Type Cover Accessory	35
11.13	WLAN 5.6 GHz Main Antenna (Path B) SAR Test Results	36
11.14	WLAN 5.6 GHz Aux. Antenna (Path A) SAR Test Results	37
11.15	WLAN 5.6 GHz SAR Test Results with Type Cover Accessory	37
11.16	WLAN 5.8 GHz Main Antenna (Path B) SAR Test Results	38
11.17	WLAN 5.8 GHz Aux. Antenna (Path A) SAR Test Results	38
11.18	WLAN 5.8 GHz SAR Test Results with Type Cover Accessory	39
11.19	Bluetooth SAR Test Results	40
12	Repeated SAR Measurements	41
12.1	SAR Variability Repeat Measurements	41
13	Simultaneous Transmission Evaluation	42
13.1	Important Standalone SAR values for Simultaneous Transmission Evaluation	42
13.2	Simultaneous Transmission Evaluation Results	43

13.2.1	Bluetooth (Antenna B) + WLAN (Antenna A) Simultaneous Transmission Analysis	43
14	SAR System Verification	44
14.1	SAR System Verification Results	45
15	Tissue-Simulating Liquid Verification	46
15.1	Tissue-Simulating Liquid Ingredients and Maintenance	47
15.2	Tissue-Simulating Liquid Measurements.....	48
16	System Specification	49
16.1	SPEAG DASY5 SYSTEM	49
17	Measurement Uncertainty	50
18	Appendices	50

2 Deviations from Standard

None.

3 Facilities and Accreditation

3.1 TEST FACILITY

All test facilities used to collect the test data are located at Microsoft EMC Laboratory: 17760 NE 67th Ct, Redmond, WA, 98052, USA.

3.2 ACCREDITATIONS

The lab is established and follows procedures as outlined in IEC/ISO 17025 and A2LA accreditation requirements.

A2LA Accredited Testing Certificate Number: 3472.01

Expiration Date: Aug 31, 2015

3.3 Test Equipment

The site and related equipment are constructed in conformance with the requirements of IEEE 1528-2013 and other equivalent applicable standards. The calibrations of the measuring instruments, including any accessories that may affect such calibration, are checked frequently to assure their accuracy. Adjustments are made and correction factors applied in accordance with instructions contained in the user manual for the measuring equipment.

4 Highest Reported SAR Values

Exposure Condition	Equipment Class	Mode of Operation	Test Position	1-g Reported SAR (W/kg)
Body Exposure	DTS	802.11n HT20	Back 0mm	1.04
	NII	802.11n HT40	Top 0mm	1.54
	Bluetooth	1-DH5	Back 0mm	0.22
	Simultaneous Transmission	Bluetooth + 802.11b	Back 0mm	1.26

Reported SAR Values are obtained by scaling the measured SAR values up to the maximum allowable output power for each configuration using the following equation:

$$SAR = MEASURED * 10^{\frac{(P_{MAX}-P)}{10}}$$

where

SAR = Reported SAR (W/kg)

MEASURED = Measured SAR (W/kg)

P_{MAX} = Maximum Conducted Average Output Power (dBm)

P = Measured Conducted Average Output Power (dBm)

4.1 SAR Limits

The following are the relevant SAR limits for FCC and IC based on the recommendations of ANSI C95.1-1999:

Exposure Condition	Limit (W/kg)
Localized Body SAR	1.6 (1-g cube)

5 Test Equipment List

Manufacturer	Description	Model #	Serial /#	Cal. Due	Cal. Cycle
Agilent	Signal Generator	N5181A	MY50144778	02/11/2015	1 yr
Agilent	Signal Generator	N5181A	MY50144791	12/18/2015	1 yr
PRANA	Power Amplifier + Directional Coupler	TU16	1305-1353	N/A	N/A
PRANA	Power Amplifier + Directional Coupler	TU16	1305-1352	N/A	N/A
PRANA	Power Amplifier + Directional Coupler	UX15	1305-1354	N/A	N/A
PRANA	Power Amplifier + Directional Coupler	UX15	1305-1355	N/A	N/A
Agilent	Power Meter	1914A	MY50801712	02/28/2015	1 yr
Agilent	Power Meter	1914A	MY50901710	12/17/2015	1 yr
Agilent	Power Sensor	9304A	MY53040017	02/24/2015	1 yr
Agilent	Power Sensor	9304A	MY53040025	02/24/2015	1 yr
Agilent	Power Sensor	9304A	MY53040024	12/24/2015	1 yr
Agilent	Power Sensor	9304A	MY53040018	12/24/2015	1 yr
Agilent	Network Analyzer	E5071C	MY46316957	02/10/2015	1 yr
Agilent	Network Analyzer	E5071C	MY46316847	12/18/2015	1 yr
Agilent	Dielectric Probe Kit	85070E	MY44300740	N/A	N/A
Agilent	Dielectric Probe Kit	85070E	MY44300736	N/A	N/A
SPEAG	DASY Data Acquisition Electronics	DAE4	1383	7/11/2015	1 yr
SPEAG	DASY Data Acquisition Electronics	DAE4	1384	7/11/2015	1 yr
SPEAG	Dosimetric E-Field Probe	EX3DV4	3939	7/17/2015	1 yr
SPEAG	Dosimetric E-Field Probe	EX3DV4	3940	7/17/2015	1 yr
SPEAG	SAR Validation Dipole, 2450 MHz	D2450V2	916	07/16/2015	1 yr
SPEAG	SAR Validation Dipole, 5 GHz	D5GHzV2	1158	07/15/2015	1 yr
SPEAG	Elliptical Phantom	ELI V5.0	1217	N/A	N/A
SPEAG	Elliptical Phantom	ELI V5.0	1218	N/A	N/A
Thomas Scientific	Mini Thermometer	9327K19	130477954	09/08/2015	1 yr
Thomas Scientific	Mini Thermometer	9327K19	130477975	09/08/2015	1 yr
Thomas Scientific	Mini Thermometer	9327K19	130477955	09/08/2015	1 yr

6 Product Description

Company Name:	Microsoft Corporation
Address:	One Microsoft Way
City, State, Zip:	Redmond, WA 98052
Customer Contact:	Sahithi Kandula
Functional Description of EUT:	Handheld computing device with 802.11 2x2 a/b/g/n/ac WLAN and Bluetooth radios
RF Exposure Conditions:	Body Exposure
Model:	1645
Equipment Design State:	DV/Productions
Equipment Condition:	Good
Radio Information:	WLAN 2.4 GHz: 802.11b, 802.11g, 802.11n WLAN 5 GHz: 802.11a, 802.11n, 802.11ac Bluetooth™ (Basic and Enhanced Data Rates)
Frequency of Operation:	WLAN: 2412 MHz – 2462 MHz 5180 MHz – 5825 MHz Bluetooth: 2402-2480 MHz
Modulations supported:	WLAN: CCK, BPSK, QPSK, 16-QAM, 64-QAM Bluetooth: GFSK, $\frac{\pi}{4}$ DQPSK, and 8 DPSK
Antenna Information:	2.4 GHz: 3.6 dBi 5 GHz: 4.2 dBi
Dates of Testing:	1/14/2015 – 1/30/2015

6.1 TEST CONFIGURATIONS

Radiated and Conducted measurements were performed with customer-provided test software “WiFi Tool” (V2.6), which utilizes “DUT Labtool” (V2.0.0.57) provided by the module manufacturer, to program the EUT in continuous transmit mode.

6.2 ENVIRONMENTAL CONDITIONS

Ambient air temperature of the test site was within the range of 18 °C to 25 °C. Testing conditions were within tolerance and any deviations required from the EUT are reported.

6.3 EQUIPMENT MODIFICATIONS

No modifications were made during testing.

6.4 EQUIPMENT UNDER TEST

Model Number	Serial Number	SW Version	FW Version
1645	00576345952	Windows 8.1	1.41214.851
1645	00567345952	Windows 8.1	1.41214.851
1645	00200544952	Windows 8.1	1.41214.851

6.4.1 Accessory Test Equipment

Description	Model Number	Serial Number
Type Cover	1654	048763733954

6.5 Supported Air Interfaces and Transmission Configurations

The EUT has two antennas which support the following air interfaces and transmission configurations. The antennas are labeled as Main Antenna (Path B) and Auxiliary Antenna (Path A).

6.5.1 Supported Air Interfaces

Band	Air Interface	BW (MHz)		
		20	40	80
WLAN 2.4 GHz	802.11b	X		
	802.11g	X		
	802.11n	X		
WLAN 5 GHz	802.11a	X		
	802.11n	X	X	
	802.11ac	X	X	X
2.4 GHz	Bluetooth	NA		
	BTLE	NA		

6.5.2 Transmission Configurations

Main Antenna (Path B)	Auxiliary Antenna (Path A)
WLAN 2.4 GHz	
	WLAN 2.4 GHz
WLAN 5 GHz	
	WLAN 5 GHz
WLAN 2.4 GHz	WLAN 2.4 GHz
WLAN 5 GHz	WLAN 5 GHz
Bluetooth	
Bluetooth	WLAN 2.4 GHz
Bluetooth	WLAN 5 GHz

7 Test Methodology

Test setup and procedure are performed according to **IEEE 1528-2013 Recommended Practice for Determining the Peak Spatial-Average Specific Absorption Rate (SAR) in the Human Head from Wireless Communication Devices: Measurement Techniques.**

In addition, the following publications were used as guidance.

For FCC SAR testing and reporting according to FCC standards the following KDBs were adhered to:

447498 D01 General RF Exposure Guidance v05r02

865664 D01 SAR Measurements Requirements for 100 MHz to 6 GHz v01r03

865664 D02 RF Exposure Reporting v01r01

616217 D04 SAR for laptops and tablets v01r01

248227 D01 SAR Measurement Procedures for 802.11 a/b/g Transmitters DR02

For Industrie Canada, RSS-102 – RF (Radio Frequency) Exposure Compliance of Radiocommunication Apparatus, Issue 4 March 2010 was adhered to. The above FCC KDB's were applied for Industrie Canada testing as well except for instances where IC rules specifically cite different required test methods.

8 Conducted RF Average Output Power Measurements

Bluetooth and WLAN output power measurements are made with the DUT connected to the power sensor of a broadband power meter.

8.1 Bluetooth Conducted Output Power Measurements

Channel	Frequency (MHz)	Conducted Average Output Power (dBm)			Maximum Target Power
		Modulation			
		GFSK	$\pi/4$ -DPSK	8DPSK	
0	2402	3.9	0.6	0.6	4
39	2440	3.65	0.35	0.38	
78	2480	3.35	0.05	0.05	

8.2 Bluetooth LE Conducted Output Power Measurements

Channel	Frequency (MHz)	Conducted Average Output Power (dBm)	
		Measured	Maximum Target Power
0	2402	3.4	4
19	2440	3.2	
39	2480	2.9	

8.3 WLAN 2.4 GHz Conducted Output Power Measurements

Mode	Chann.	Freq. (MHz)	Maximum Conducted Average Output Power (dBm)							
			SISO (1 TX)				MIMO (2 TX)			
			Main Ant		Aux Ant		Main Ant		Aux Ant	
			Meas.	Max	Meas.	Max	Meas.	Max	Meas.	Max
802.11b 1Mbps	1	2412	10.15	11.5	9.56	11.5	10.24	11.5	9.5	11.5
	6	2437	10.52	11.5	9.68	11.5	10.5	11.5	9.5	11.5
	11	2462	10.42	11.5	9.53	11.5	10.45	11.5	9.66	11.5
802.11g 6Mbps	1	2412	9.48	11.5	9.26	11.5	9.28	11.5	9.39	11.5
	6	2437	9.63	11.5	9.28	11.5	9.43	11.5	9.4	11.5
	11	2462	9.88	11.5	9.26	11.5	9.6	11.5	9.2	11.5
802.11n HT20 MCS0	1	2412	10.38	11.5	10.22	11.5	10.35	11.5	10.24	11.5
	6	2437	10.34	11.5	10.27	11.5	10.8	11.5	10.26	11.5
	11	2462	10.68	11.5	10.4	11.5	10.62	11.5	10.32	11.5

8.4 WLAN 5 GHz Conducted Output Power Measurements

8.4.1 5.2 GHz Conducted Measurements (U-NII-1)

Mode	Chann.	Freq. (MHz)	Maximum Conducted Average Output Power (dBm)							
			SISO (1 TX)				MIMO (2 TX)			
			Main Ant		Aux Ant		Main Ant		Aux Ant	
			Meas.	Max	Meas.	Max	Meas.	Max	Meas.	Max
802.11a 6Mbps	36	5180	7.7	7.8	7.68	7.8	7.7	7.8	7.6	7.8
	40	5200	7.5	7.8	7.51	7.8	7.7	7.8	7.48	7.8
	44	5220	7.55	7.8	7.7	7.8	7.7	7.8	7.6	7.8
	48	5240	7.7	7.8	7.7	7.8	7.7	7.8	7.55	7.8
802.11n HT20 MCS0	36	5180	7.7	7.8	7.58	7.8	7.55	7.8	7.31	7.8
	40	5200	7.7	7.8	7.47	7.8	7.53	7.8	7.52	7.8
	44	5220	7.57	7.8	7.67	7.8	7.64	7.8	7.61	7.8
	48	5240	7.7	7.8	7.45	7.8	7.62	7.8	7.55	7.8
802.11n HT40 MCS0	38	5190	7.54	7.8	7.54	7.8	7.29	7.8	7	7.8
	46	5230	7.42	7.8	7.7	7.8	7.28	7.8	7.08	7.8
802.11ac VHT20 MCS0	36	5180	7.54	7.8	7.6	7.8	7.33	7.8	7.31	7.8
	40	5200	7.7	7.8	7.67	7.8	7.53	7.8	7.44	7.8
	44	5220	7.6	7.8	7.58	7.8	7.53	7.8	7.33	7.8
	48	5240	7.7	7.8	7.7	7.8	7.56	7.8	7.55	7.8
802.11ac VHT40 MCS0	38	5190	7.6	7.8	7.58	7.8	6.89	7.8	7.2	7.8
	46	5230	7.65	7.8	7.44	7.8	7.31	7.8	6.91	7.8
802.11ac VHT80 MCS0	42	5210	6.47	6.8	6.09	6.8	6.02	6.8	5.45	6.8

8.4.2 5.3 GHz Conducted Measurements (U-NII-2A)

Mode	Chann.	Freq. (MHz)	Maximum Conducted Average Output Power (dBm)							
			SISO (1 TX)				MIMO (2 TX)			
			Main Ant		Aux Ant		Main Ant		Aux Ant	
			Meas.	Max	Meas.	Max	Meas.	Max	Meas.	Max
802.11a 6Mbps	52	5260	7.63	7.8	7.6	7.8	7.45	7.8	7.55	7.8
	56	5280	7.7	7.8	7.61	7.8	7.45	7.8	7.27	7.8
	60	5300	7.62	7.8	7.54	7.8	7.43	7.8	7.55	7.8
	64	5320	7.43	7.8	7.48	7.8	7.41	7.8	7.41	7.8
802.11n HT20 MCS0	52	5260	7.46	7.8	7.46	7.8	7.23	7.8	7.55	7.8
	56	5280	7.6	7.8	7.6	7.8	7.35	7.8	7.34	7.8
	60	5300	7.21	7.8	7.21	7.8	7.31	7.8	7.23	7.8
	64	5320	7.42	7.8	7.42	7.8	7.34	7.8	7.35	7.8
802.11n HT40 MCS0	54	5270	7.31	7.8	7.47	7.8	7.1	7.8	7.23	7.8
	62	5310	7.3	7.8	7.25	7.8	7.07	7.8	7.02	7.8
802.11ac VHT20 MCS0	52	5260	7.38	7.8	7.56	7.8	7.37	7.8	7.35	7.8
	56	5280	7.2	7.8	7.34	7.8	7.29	7.8	7.48	7.8
	60	5300	7.5	7.8	7.6	7.8	7.31	7.8	7.46	7.8
	64	5320	7.17	7.8	7.39	7.8	7.06	7.8	7.54	7.8
802.11ac VHT40 MCS0	54	5270	7.54	7.8	7.29	7.8	6.82	7.8	7.05	7.8
	62	5310	7.2	7.8	7.29	7.8	7.13	7.8	7.2	7.8
802.11ac VHT80 MCS0	56	5290	5.57	6.8	6.04	6.8	5.6	6.8	5.99	6.8

8.4.3 5.6 GHz Conducted Measurements (U-NII-2C)

Mode	Chann.	Freq. (MHz)	Maximum Conducted Average Output Power (dBm)							
			SISO (1 TX)				MIMO (2 TX)			
			Main Ant		Aux Ant		Main Ant		Aux Ant	
			Meas.	Max	Meas.	Max	Meas.	Max	Meas.	Max
802.11a 6Mbps	100	5500	6.6	7.8	7.2	7.8	6.5	7.8	7.2	7.8
	104	5520	6.7	7.8	7.3	7.8	6.4	7.8	7.45	7.8
	108	5540	6.4	7.8	7.15	7.8	6.5	7.8	7.25	7.8
	112	5560	6.7	7.8	7.1	7.8	6.6	7.8	7.2	7.8
	116	5580	6.75	7.8	7.25	7.8	6.55	7.8	7.1	7.8
	120	5600	6.7	7.8	7.05	7.8	6.8	7.8	7.15	7.8
	124	5620	6.85	7.8	7.05	7.8	6.75	7.8	6.9	7.8
	128	5640	6.65	7.8	6.7	7.8	6.8	7.8	6.8	7.8
	132	5660	6.7	7.8	6.7	7.8	6.7	7.8	6.4	7.8
	136	5680	6.65	7.8	6.4	7.8	6.8	7.8	6.5	7.8
802.11n HT20 MCS0	100	5500	6.6	7.8	7.35	7.8	6.4	7.8	7.35	7.8
	104	5520	6.5	7.8	7.4	7.8	6.4	7.8	7.4	7.8
	108	5540	6.65	7.8	7.35	7.8	6.6	7.8	7.3	7.8
	112	5560	6.6	7.8	7.2	7.8	6.4	7.8	7.2	7.8
	116	5580	6.85	7.8	7.1	7.8	6.8	7.8	7.25	7.8
	120	5600	6.75	7.8	7.2	7.8	6.7	7.8	7.15	7.8
	124	5620	6.9	7.8	6.9	7.8	6.8	7.8	7	7.8
	128	5640	6.8	7.8	6.8	7.8	6.7	7.8	6.65	7.8
	132	5660	6.9	7.8	6.5	7.8	6.8	7.8	6.65	7.8
	136	5680	6.8	7.8	6.55	7.8	6.5	7.8	6.3	7.8
802.11n HT40 MCS0	102	5510	6.4	7.8	7.25	7.8	6.3	7.8	6.55	7.8
	110	5550	6.65	7.8	7.15	7.8	6.1	7.8	7	7.8
	118	5590	6.85	7.8	7.1	7.8	6.3	7.8	6.5	7.8
	126	5630	6.85	7.8	6.75	7.8	6.5	7.8	6.55	7.8
	134	5670	6.75	7.8	6.4	7.8	6.2	7.8	6.15	7.8

5.6 GHz Conducted Measurements (U-NII-2C) Continued

Mode	Chann.	Freq. (MHz)	Maximum Conducted Average Output Power (dBm)							
			SISO (1 TX)				MIMO (2 TX)			
			Main Ant		Aux Ant		Main Ant		Aux Ant	
			Meas.	Max	Meas.	Max	Meas.	Max	Meas.	Max
802.11ac VHT20 MCS0	100	5500	6.65	7.8	7.3	7.8	6.35	7.8	7.15	7.8
	104	5520	6.5	7.8	7.3	7.8	6.45	7.8	7.1	7.8
	108	5540	6.65	7.8	7.25	7.8	6.25	7.8	7.2	7.8
	112	5560	6.5	7.8	7	7.8	6.6	7.8	7.1	7.8
	116	5580	6.7	7.8	7.1	7.8	6.35	7.8	7	7.8
	120	5600	6.9	7.8	7.05	7.8	6.65	7.8	6.95	7.8
	124	5620	6.85	7.8	6.7	7.8	6.4	7.8	6.55	7.8
	128	5640	6.75	7.8	6.65	7.8	6.7	7.8	6.35	7.8
	132	5660	6.95	7.8	6.15	7.8	6.5	7.8	6.3	7.8
	136	5680	6.7	7.8	6.15	7.8	6.55	7.8	6	7.8
802.11ac VHT40 MCS0	102	5510	6.4	7.8	7.25	7.8	6	7.8	6.7	7.8
	110	5550	6.4	7.8	7.15	7.8	6	7.8	6.35	7.8
	118	5590	6.6	7.8	6.85	7.8	6.2	7.8	6.7	7.8
	126	5630	6.65	7.8	6.65	7.8	5.9	7.8	6.2	7.8
802.11ac VHT80 MCS0	106	5530	6.4	6.8	6.8	6.8	5.4	6.8	6.35	6.8
	122	5610	6.75	6.8	6.65	6.8	5.6	6.8	6.1	6.8

8.4.4 5.8 GHz Conducted Measurements (U-NII-3)

Mode	Chann.	Freq. (MHz)	Maximum Conducted Average Output Power (dBm)							
			SISO (1 TX)				MIMO (2 TX)			
			Main Ant		Aux Ant		Main Ant		Aux Ant	
			Meas.	Max	Meas.	Max	Meas.	Max	Meas.	Max
802.11a 6Mbps	149	5745	6.85	7.8	6.5	7.8	6.9	7.8	6.6	7.8
	153	5765	6.8	7.8	6.7	7.8	6.8	7.8	6.75	7.8
	157	5785	6.6	7.8	6.8	7.8	6.7	7.8	6.9	7.8
	161	5805	7	7.8	7	7.8	6.9	7.8	6.8	7.8
	165	5825	7.05	7.8	7.1	7.8	7.05	7.8	7.2	7.8
802.11n HT20 MCS0	149	5745	6.85	7.8	6.6	7.8	6.65	7.8	6.5	7.8
	153	5765	6.55	7.8	6.7	7.8	6.75	7.8	6.75	7.8
	157	5785	6.7	7.8	6.9	7.8	6.65	7.8	6.9	7.8
	161	5805	7	7.8	7.1	7.8	6.6	7.8	7.1	7.8
802.11n HT40 MCS0	151	5755	6.7	7.8	6.5	7.8	6.05	7.8	6.6	7.8
	159	5795	6.8	7.8	6.95	7.8	6.35	7.8	6.95	7.8
802.11ac VHT20 MCS0	149	5745	6.75	7.8	6.55	7.8	6.65	7.8	6.5	7.8
	153	5765	6.5	7.8	6.8	7.8	6.6	7.8	6.75	7.8
	157	5785	6.65	7.8	6.95	7.8	6.55	7.8	6.9	7.8
	161	5805	6.8	7.8	7.1	7.8	6.6	7.8	7.1	7.8
802.11ac VHT40 MCS0	165	5825	7.1	7.8	7.25	7.8	6.75	7.8	7.15	7.8
	151	5755	6.6	7.8	6.55	7.8	6.3	7.8	6.5	7.8
802.11ac VHT80 MCS0	159	5795	6.6	7.8	6.9	7.8	5.75	7.8	6.9	7.8
	155	5775	6.6	6.8	6.6	6.8	5.75	6.8	6.65	6.8

8.5 Power Measurements at Higher Data Rates

Based on the conducted output power measurements at the lowest data rates, conducted power measurements at higher data rates were performed on the highest power channels in each band. These measurements are used to confirm that higher data rates do not give higher output power than the lowest data rates. From **KDB 248227 SAR Measurement Procedures for 802.11 a/b/g Transmitters v01r02**:

When maximum SAR for the lowest data rate conditions are sufficiently below the SAR limit and the maximum average output power of the other data rates and modulations are lower, extensive SAR measurements at higher data rates are typically unnecessary.

8.5.1 WLAN 2.4 GHz Conducted Power Measurements at Higher Data Rates

802.11b		
Data Rate (Mbps)	Modulation	Maximum Conducted Avg. Output Power (dBm)
		Ch. 6 2437 MHz
1	DBPSK	10.52
2	DQPSK	10.45
5.5	CCK	9.9
11	CCK	9.85

802.11n HT20		
Data Rate (Mbps)	Modulation	Maximum Conducted Avg. Output Power (dBm)
		Ch. 11 2462 MHz
6.5 (MCS0)	BPSK	10.68
13 (MCS1)	QPSK	10.6
19.5 (MCS2)	QPSK	10.6
26 (MCS3)	16-QAM	10.5
39 (MCS4)	16-QAM	10.4
52 (MCS5)	64-QAM	10.25
58.5 (MCS6)	64-QAM	10.2
65 (MCS7)	64-QAM	10.2

8.5.2 WLAN 5 GHz Conducted Power Measurements at Higher Data Rates

802.11a					
Data Rate (Mbps)	Modulation	Maximum Conducted Avg. Output Power (dBm)			
		Ch. 48 5240 MHz	Ch. 56 5280 MHz	Ch. 104 5520 MHz	Ch. 165 5825 MHz
6	BPSK	7.7	7.7	7.45	7.2
9	BPSK	7.57	7.61	7.4	7.05
12	QPSK	7.57	7.43	7.4	7
18	QPSK	7.48	7.4	7.35	6.9
24	16-QAM	7.47	7.2	7.3	6.85
36	16-QAM	7.24	7.01	7	6.6
48	64-QAM	7.18	7.04	6.8	6.6
54	64-QAM	6.91	7	6.75	6.45

802.11n HT40					
Data Rate (Mbps)	Modulation	Maximum Conducted Avg. Output Power (dBm)			
		Ch. 46 5230 MHz	Ch. 54 5270 MHz	Ch. 102 5510 MHz	Ch. 159 5795 MHz
13.5 (MCS0)	BPSK	7.7	7.47	7.25	6.95
27 (MCS1)	QPSK	7.33	7.4	7.15	6.7
40.5 (MCS2)	QPSK	7.24	7.32	7.05	6.6
54 (MCS3)	16-QAM	7.04	7.23	6.9	6.4
81 (MCS4)	16-QAM	6.93	7	6.55	6.25
108 (MCS5)	64-QAM	6.78	6.84	6.45	6.1
121.5 (MCS6)	64-QAM	6.58	6.76	6.35	6.05
135 (MCS7)	64-QAM	6.62	6.52	6.25	6

9 Test Configurations

The standalone SAR test exclusion equations (KDB 447498 D01 4.3.1) are used to determine which device edges and faces require testing for a given antenna and air interface technology. From **KDB 616217 D04 v01r01** (SAR for laptop and tablets) section 4.3, the SAR test exclusion threshold from KDB 447498 can be applied to determine SAR test exclusion for adjacent edge configurations. The closest distance from the antenna to an adjacent edge is used to determine if SAR testing is required for the adjacent edges. SAR evaluation for the front surface of tablet display screens is not necessary since it is not expected to exceed the extremity SAR limit.

- 1) For antenna to edge separation distances $\leq 50\text{mm}$, the 1-g SAR test exclusion threshold can be determined by evaluating whether the following is true:

$$\frac{P_{max}}{d} * \sqrt{f} \leq 3.0$$

- P_{max} = maximum possible average conducted power of transmitter, including tolerances (mW)
- d = closest intended separation distance between transmitting antenna and edge / face of device (mm) (5mm at the least)
- f = frequency of the transmitter for that power level in GHz

- 2) For antenna to edge separation distances $> 50\text{mm}$, the SAR test exclusion threshold is determined according to the following:

- a) [Power allowed at numeric threshold for 50 mm in step 1) + (test separation distance - 50 mm) \cdot ($f_{(\text{MHz})}/150$)] mW, at 100 MHz to 1500 MHz
- b) [Power allowed at numeric threshold for 50 mm in step 1) + (test separation distance - 50 mm) \cdot 10] mW at > 1500 MHz and ≤ 6 GHz

9.1 Evaluation of Required Test Configurations

The following table shows the most conservative parameters used for SAR Test Exclusion Evaluation for each air interface technology:

Parameters used to Evaluate SAR Test Exclusion	Air Interface		
	WLAN 2.4 GHz	WLAN 5 GHz	BT
Max Freq. (GHz)	2.462	5.825	2.48
Max Power including Tune-up tolerances (mW)	14.13 (11.5 dBm)	6.03 (7.8 dBm)	3.55 (5.5 dBm)

The following table shows the SAR test exclusion thresholds for the given edge / face and air interface combinations, and whether SAR testing is required for each combination. Testing is required for a given configuration when the Max Power from the table above is greater than the exclusion threshold in the table below.

Standalone SAR Test Exclusion	WLAN Antenna A (Aux)				WLAN Antenna B (Main)				
	Device Side	Separation Distance (mm)	Exclusion Threshold (mW)			Separation Distance (mm)	Exclusion Threshold (mW)		
			WLAN 2.4 GHz	WLAN 5 GHz	BT		WLAN 2.4 GHz	WLAN 5 GHz	BT
Top Edge	5	9.56	6.22	9.53	5	9.56	6.22	9.53	
Bottom Edge	183	349.89	227.47	348.62	183	349.89	227.47	348.62	
Left Edge	165.4	316.24	205.59	315.09	76.83	146.90	95.50	146.36	
Right Edge	72.4	138.43	89.99	137.92	137.84	263.54	171.34	262.59	
Back	5	9.56	6.22	9.53	5	9.56	6.22	9.53	

See attachments for antenna locations diagram.

 SAR Testing Required and Performed

 SAR Testing Not Required

 SAR Testing Performed though Not Required

9.2 Test Positions

This device features beveled edges which a user could have flat against their body. For any device edge which required traditional testing (the device edge perpendicular to the phantom), tests were also performed on that edge with the bevel parallel to the phantom surface. This requires the device itself to be tilted as shown in the test setup photos.

Exposure Condition	Phantom Used	DUT Test Position	Test Setup Photo (See Appendix)
Body	Flat Section (SAM, ELI, or Triple-Flat)	Back 0mm	Photo 1
		Top Edge 0mm	Photo 2
		Top Tilt 0mm	Photo 3

9.3 Additional Test Positions with Accessory Attached

This device supports use with an optional keyboard / cover accessory. The following test configurations were also performed with this accessory attached to the device and folded back as it would be in typical use exposure conditions.

Exposure Condition	Phantom Used	DUT Test Position	Test Setup Photo (See Appendix)
Body	Flat Section (SAM, ELI, or Triple-Flat)	Back 0mm with Type Cover	Photo 4
		Top Edge 0mm with Type Cover	Photo 5
		Top Tilt 0mm with Type Cover	Photo 6

10 SAR Test Procedures

The SAR Evaluation was performed in the following steps:

- **Power Reference Measurement.**

The Power Measurement and Power Drift Measurements are for monitoring the power drift of the device under test. The minimum distance of probe sensors to surface determines the closest measurement point to phantom surface. The minimum distance of probe sensors to surface is set to 2mm for the EX3DV4 probe as recommended by SPEAG. The Power Reference Measurement is taken at a point close to the antenna whose output is being measured in order to maximize SNR, thus minimizing drift error.

- **Area Scan**

The Area Scan is used as a fast scan in two dimensions to find the areas of high field values (or hot spots), before doing a fine measurement around the hotspot. The sophisticated interpolation routines implemented in DASY5 software can find the maximum locations even in relatively coarse grids. When an Area Scan has measured all reachable points, it computes the field maxima found and lists all maxima found in the scan area within a certain range of the global maximum. A 2 dB range is required by IEEE STD 1528. Zoom scans need only be performed on all secondary maxima within this range when the absolute maximum found is under 2 dB less than the SAR limit in question (i.e., less than 1 W/kg for the 1.6 W/kg SAR limit). Otherwise, the zoom scan is only performed at the highest maxima found in the area scan. The exception to this is in MIMO configurations where at least one zoom scan should be measured per transmit antenna.

The following x-y grid spacings for the given transmitter frequency ranges are used for area scans in accordance with FCC KDB 865664 D01 SAR Measurement 100 MHz to 6 GHz:

700 MHz – 2 GHz: ≤ 15 mm

2 GHz – 4 GHz: ≤ 12 mm

4 GHz – 6 GHz: ≤ 10 mm

- **Zoom Scan**

Zoom Scans are used to assess the peak spatial SAR values within a cubic averaging volume containing 1g or 10g of simulated tissue. When the measurement is done, the Zoom Scan evaluates the averaged SAR for 1g and 10g and displays these values next to the job's label. The sides of the zoom scan cube should be parallel to the edges of the EUT when possible. The dimensions of a Zoom Scan and spacing between measurement points vary by frequency according to FCC KDB 865664 D01 SAR Measurement 100 MHz to 6 GHz, shown in Table 2 below:

Table 2: Zoom Scan Dimensions

Transmitter Frequency Range	Cube Dimensions	x-y coordinate spatial resolution	z coordinate spatial resolution
700 MHz – 2 GHz	≥ 30 mm	≤ 8 mm	≤ 5 mm
2 GHz – 3 GHz	≥ 28 mm	≤ 5 mm, *≤ 8 mm	≤ 4 mm
3 – 4 GHz	≥ 25 mm	≤ 5 mm, *≤ 7 mm	≤ 3 mm
4 – 6 GHz	≥ 22 mm	≤ 4 mm, *≤ 5 mm	≤ 2 mm

*optional x-y coordinate spatial resolution when Area Scan SAR ≤ 87.5% of applicable SAR limit

○ **Power Drift Measurement**

The Power Drift Measurement measures the field at the same location as the most recent power reference measurement within the same procedure, and with the same settings. The Power Drift Measurement gives the field difference in dB from the reading conducted within the last Power Reference Measurement. The absolute value of this difference must be ≤ 0.21 dB; if it is not, the entire test is repeated or the difference accounted for.

11 SAR Test Results

11.1 General SAR Testing Notes

- From **KDB 447498 D01 General RF Exposure Guidance v05r02**, the following test channel reduction was applied to each test position of an exposure condition in each wireless mode and configuration. Initial testing for each test position for each band was performed on the middle required test channel (or required test channel with the highest power for 5 GHz modes). Testing of other required channels within the operating mode of a frequency band is not required when the *reported* 1-g or 10-g SAR for the mid-band or highest output power channel is:
 - ≤ 0.8 W/kg or 2.0 W/kg, for 1-g or 10-g respectively, when the transmission band is ≤ 100 MHz
 - ≤ 0.6 W/kg or 1.5 W/kg, for 1-g or 10-g respectively, when the transmission band is between 100 MHz and 200 MHz
- Initial testing in all modes was performed without the optional accessory type cover. Testing with the type cover attached to the device and folded back was performed on the worst case test position and mode for all bands for each transmit antenna.
- All WLAN measurements were made with the device transmitting at 100% duty cycle.
- Tissue-simulating liquid temperature was maintained within $\pm 2^{\circ}\text{C}$ of that which was measured during liquid verification.

11.2 WLAN 2.4 GHz SAR Testing Notes

(Guidance from KDB 248227 v01r02)

- Initial testing was performed in 802.11b mode
- Testing was not performed in 802.11g mode since the measured average output power for 802.11g is less than 0.25 greater than that measured for 802.11b.
- Testing in 802.11n mode was performed in the worst-case configuration found in 802.11b SAR testing. It was performed at the highest bandwidth that uses the maximum supported tune-up power of 802.11n. (HT40 is not supported for 2.4 GHz so HT20 was tested.)
- MIMO (simultaneous transmission of Path A and Path B) was tested in 802.11n mode.

11.3 WLAN 2.4 GHz Main Antenna (Path B) SAR Test Results

Mode	BW (MHz)	Ant.	Position	Ch.	Freq. (MHz)	Avg. Pwr. (dBm)	Max. Pwr. (dBm)	Meas. 1g SAR (W/kg)	Reported 1g SAR (W/kg)
802.11b 1 Mbps 1TX	20	B	Top	6	2437	10.52	11.5	0.101	0.13
	20	B	Top Tilt	6	2437	10.52	11.5	0.109	0.14
	20	B	Back	1	2412	10.15	11.5	0.632	0.86
	20	B	Back	6	2437	10.52	11.5	0.675	0.85
	20	B	Back	11	2462	10.42	11.5	0.708	0.91
802.11n MCS0 1TX	20	B	Back	1	2412	10.38	11.5	0.624	0.81
	20	B	Back	6	2437	10.34	11.5	0.723	0.94
	20	B	Back	11	2462	10.68	11.5	0.709	0.86
802.11n MCS0 2TX	20	B	Top	6	2437	10.8	11.5	0.1	0.12
	20	B	Top Tilt	6	2437	10.8	11.5	0.122	0.14
	20	B	Back	1	2412	10.35	11.5	0.592	0.77
	20	B	Back	6	2437	10.8	11.5	0.695	0.82
	20	B	Back	11	2462	10.62	11.5	0.668	0.82

11.4 WLAN 2.4 GHz Aux. Antenna (Path A) SAR Test Results

Mode	BW (MHz)	Ant.	Position	Ch.	Freq. (MHz)	Avg. Pwr. (dBm)	Max. Pwr. (dBm)	Meas. 1g SAR (W/kg)	Reported 1g SAR (W/kg)
802.11b 1 Mbps 1TX	20	A	Top	6	2437	9.68	11.5	0.0993	0.15
	20	A	Top Tilt	6	2437	9.68	11.5	0.135	0.21
	20	A	Back	1	2412	9.56	11.5	0.623	0.97
	20	A	Back	6	2437	9.68	11.5	0.601	0.91
	20	A	Back	11	2462	9.53	11.5	0.601	0.95
802.11n MCS0 1TX	20	A	Back	1	2412	10.22	11.5	0.774	1.04 (Plot 1)
	20	A	Back	6	2437	10.27	11.5	0.782	1.04
	20	A	Back	11	2462	10.4	11.5	0.719	0.93
802.11n MCS0 2TX	20	A	Top	6	2437	10.26	11.5	0.113	0.15
	20	A	Top Tilt	6	2437	10.26	11.5	0.146	0.19
	20	A	Back	1	2412	10.24	11.5	0.72	0.96
	20	A	Back	6	2437	10.26	11.5	0.761	1.01 (Plot 2)
	20	A	Back	11	2462	10.32	11.5	0.686	0.90

11.5 WLAN 2.4 GHz SAR Test Results with Type Cover Accessory

Mode	BW (MHz)	Ant.	Position	Ch.	Freq. (MHz)	Avg. Pwr. (dBm)	Max. Pwr. (dBm)	Meas. 1g SAR (W/kg)	Reported 1g SAR (W/kg)
802.11n MCS0 1TX	20	A	Back w/Type Cover	1	2412	10.22	11.5	0.195	0.26
802.11n MCS0 1TX	20	B	Back w/Type Cover	6	2437	10.34	11.5	0.162	0.21

11.6 WLAN 5 GHz SAR Testing Notes

- Guidance from **KDB 248227 v01r02** was followed in choosing required test channels.
 - For each antenna, the channel with the highest output power in each sub-band was chosen as the initial test channel. If this highest-power channel was not a default test channel, it replaced an adjacent “default test channel” as a “required test channel” (Blue checks in the table below note the “default test channels.” A channel noted by a red asterisk is only tested if it is has the highest power in a sub-band.)
 - The remaining default test channels were only tested according the test channel reduction already noted previously in the General SAR Testing Notes section.
- Testing in 802.11n mode was performed in the worst-case configuration found in 802.11a SAR testing. It was performed at the highest bandwidth that uses the maximum supported tune-up power of 802.11n.
- MIMO (simultaneous transmission of Path A and Path B) was tested in 802.11a mode.
- 802.11ac SAR is tested according to the note from the **April 2013 TCB Workshop RF Exposure Procedures Update** which says to “include 802.11ac SAR for the highest 802.11a configuration in each 5 GHz band and exposure condition.”

Mode	GHz	Channel	Turbo Channel	“Default Test Channels”		UNII	
				§15.247			
				802.11b	802.11g		
802.11 b/g	2.412	1*		√	▽		
	2.437	6	6	√	▽		
	2.462	11*		√	▽		
802.11a	5.18	36				√	
	5.20	40	42 (5.21 GHz)				*
	5.22	44					*
	5.24	48	50 (5.25 GHz)			√	
	5.26	52				√	
	5.28	56	58 (5.29 GHz)				*
	5.30	60					*
	5.32	64				√	
	5.500	100	Unknown				*
	5.520	104				√	
	5.540	108					*
	5.560	112					*
	5.580	116				√	
	5.600	120					*
	5.620	124				√	
	5.640	128					*
	5.660	132					*
	5.680	136				√	
	5.700	140				*	
	UNII or §15.247	5.745	149		√		√
5.765		153	152 (5.76 GHz)		*		*
5.785		157		√			*
5.805		161	160 (5.80 GHz)		*	√	
§15.247	5.825	165		√			

11.7 WLAN 5.2 GHz Main Antenna (Path B) SAR Test Results

Mode	BW (MHz)	Ant.	Position	Ch.	Freq. (MHz)	Avg. Pwr. (dBm)	Max. Pwr. (dBm)	Meas. 1g SAR (W/kg)	Reported 1g SAR (W/kg)
802.11a 6 Mbps 1TX	20	B	Back	36	5180	7.7	7.8	0.403	0.41
	20	B	Top	36	5180	7.7	7.8	1.28	1.31
	20	B	Top	48	5240	7.7	7.8	1.32	1.35 (Repeat)
	20	B	Top Tilt	36	5180	7.7	7.8	1.03	1.05
	20	B	Top Tilt	48	5240	7.7	7.8	1.00	1.02
802.11n MCS0 1TX	40	B	Top	38	5190	7.54	7.8	1.12	1.19
	40	B	Top	46	5230	7.42	7.8	1.22	1.33
802.11ac MCS0 1TX	80	B	Top	42	5210	6.47	6.8	0.915	0.99
802.11a 6 Mbps 2TX	20	B	Back	36	5180	7.6	7.8	0.409	0.43
	20	B	Top	36	5180	7.7	7.8	1.24	1.27
	20	B	Top	48	5240	7.7	7.8	1.17	1.20
	20	B	Top Tilt	36	5180	7.7	7.8	1.05	1.07
	20	B	Top Tilt	48	5240	7.7	7.8	1.05	1.07

11.8 WLAN 5.2 GHz Aux. Antenna (Path A) SAR Test Results

Mode	BW (MHz)	Ant.	Position	Ch.	Freq. (MHz)	Avg. Pwr. (dBm)	Max. Pwr. (dBm)	Meas. 1g SAR (W/kg)	Reported 1g SAR (W/kg)
802.11a 6 Mbps 1TX	20	A	Back	48	5240	7.7	7.8	0.42	0.43
	20	A	Top	48	5240	7.7	7.8	0.55	0.56
	20	A	Top Tilt	48	5240	7.7	7.8	0.64	0.65
802.11n MCS0 1TX	40	A	Top Tilt	46	5230	7.7	7.8	0.60	0.61
802.11a 6 Mbps 2TX	20	A	Back	36	5180	7.6	7.8	0.393	0.41
	20	A	Top	48	5240	7.55	7.8	0.488	0.52
	20	A	Top Tilt	48	5240	7.55	7.8	0.6	0.64

11.9 WLAN 5.2 GHz SAR Test Results with Type Cover Accessory

Mode	BW (MHz)	Ant.	Position	Ch.	Freq. (MHz)	Avg. Pwr. (dBm)	Max. Pwr. (dBm)	Meas. 1g SAR (W/kg)	Reported 1g SAR (W/kg)
802.11a 6 Mbps 1TX	20	A	Top Tilt w/Type Cover	48	5240	7.7	7.8	0.646	0.66
802.11n MCS0 1TX	40	B	Top w/Type Cover	48	5240	7.7	7.8	1.32	1.35

11.10 WLAN 5.3 GHz Main Antenna (Path B) SAR Test Results

Mode	BW (MHz)	Ant.	Position	Ch.	Freq. (MHz)	Avg. Pwr. (dBm)	Max. Pwr. (dBm)	Meas. 1g SAR (W/kg)	Reported 1g SAR (W/kg)
802.11a 6 Mbps 1TX	20	B	Back	56	5280	7.7	7.8	0.46	0.47
	20	B	Top	56	5280	7.7	7.8	1.22	1.25
	20	B	Top	64	5320	7.43	7.8	1.17	1.27
	20	B	Top Tilt	56	5280	7.7	7.8	1.12	1.15
	20	B	Top Tilt	64	5320	7.43	7.8	1.16	1.26
802.11n MCS0 1TX	40	B	Top	54	5290	7.31	7.8	1.19	1.33
	40	B	Top	62	5310	7.3	7.8	1.13	1.27
802.11ac MCS0 1TX	80	B	Top	58	5290	5.6	6.8	0.803	1.06
802.11a 6 Mbps 2TX	20	B	Back	52	5260	7.45	7.8	0.47	0.51
	20	B	Top	52	5260	7.45	7.8	1.24	1.34
	20	B	Top	60	5300	7.43	7.8	1.29	1.40 (Plot 4)
	20	B	Top Tilt	52	5260	7.45	7.8	1.09	1.18
	20	B	Top Tilt	60	5300	7.43	7.8	0.997	1.09

11.11 WLAN 5.3 GHz Aux. Antenna (Path A) SAR Test Results

Mode	BW (MHz)	Ant.	Position	Ch.	Freq. (MHz)	Avg. Pwr. (dBm)	Max. Pwr. (dBm)	Meas. 1g SAR (W/kg)	Reported 1g SAR (W/kg)
802.11a 6 Mbps 1TX	20	A	Back	56	5280	7.61	7.8	0.454	0.47
	20	A	Top	56	5280	7.61	7.8	0.583	0.61
	20	A	Top Tilt	56	5280	7.61	7.8	0.619	0.65
802.11n MCS0 1TX	40	A	Top Tilt	54	5270	7.47	7.8	0.62	0.67
802.11a 6 Mbps 2TX	20	A	Back	52	5260	7.55	7.8	0.432	0.46
	20	A	Top	52	5260	7.55	7.8	0.575	0.61
	20	A	Top Tilt	52	5260	7.55	7.8	0.631	0.67

11.12 WLAN 5.3 GHz SAR Test Results with Type Cover Accessory

Mode	BW (MHz)	Ant.	Position	Ch.	Freq. (MHz)	Avg. Pwr. (dBm)	Max. Pwr. (dBm)	Meas. 1g SAR (W/kg)	Reported 1g SAR (W/kg)
802.11a 6 Mbps 1TX	20	A	Top Tilt w/Type Cover	56	5280	7.61	7.8	0.573	0.60
802.11a 6 Mbps 2TX	20	B	Top w/Type Cover	60	5300	7.43	7.8	1.22	1.33

11.13 WLAN 5.6 GHz Main Antenna (Path B) SAR Test Results

Mode	BW (MHz)	Ant.	Position	Ch.	Freq. (MHz)	Avg. Pwr. (dBm)	Max. Pwr. (dBm)	Meas. 1g SAR (W/kg)	Reported 1g SAR (W/kg)
802.11a 6 Mbps 1TX	20	B	Back	124	5620	6.85	7.8	0.366	0.46
	20	B	Top	104	5520	6.7	7.8	0.997	1.28
	20	B	Top	116	5580	6.75	7.8	1.07	1.36
	20	B	Top	124	5620	6.85	7.8	1.09	1.36
	20	B	Top	136	5680	6.65	7.8	1.15	1.50
	20	B	Top Tilt	104	5520	6.7	7.8	0.814	1.05
	20	B	Top Tilt	116	5580	6.75	7.8	0.858	1.09
	20	B	Top Tilt	124	5620	6.85	7.8	0.885	1.10
	20	B	Top Tilt	136	5680	6.65	7.8	0.917	1.20
802.11n MCS0 1TX	40	B	Top	102	5510	6.4	7.8	1.02	1.41
	40	B	Top	118	5590	6.85	7.8	1.09	1.36
	40	B	Top	126	5630	6.85	7.8	1.12	1.39
	40	B	Top	134	5670	6.75	7.8	1.21	1.54 (Plot 5)
802.11ac MCS0 1TX	80	B	Top	122	5610	6.75	6.8	1.06	1.07
802.11a 6 Mbps 2TX	20	B	Back	104	5520	6.4	7.8	0.291	0.40
	20	B	Top	104	5520	6.4	7.8	0.966	1.33
	20	B	Top	116	5580	6.55	7.8	1.06	1.41
	20	B	Top	124	5620	6.8	7.8	1.12	1.41
	20	B	Top	136	5680	6.75	7.8	1.1	1.40
	20	B	Top Tilt	104	5520	6.4	7.8	0.866	1.20
	20	B	Top Tilt	116	5580	6.55	7.8	0.986	1.31
	20	B	Top Tilt	124	5620	6.8	7.8	0.992	1.25
	20	B	Top Tilt	136	5680	6.75	7.8	0.994	1.27

11.14 WLAN 5.6 GHz Aux. Antenna (Path A) SAR Test Results

Mode	BW (MHz)	Ant.	Position	Ch.	Freq. (MHz)	Avg. Pwr. (dBm)	Max. Pwr. (dBm)	Meas. 1g SAR (W/kg)	Reported 1g SAR (W/kg)
802.11a 6 Mbps 1TX	20	A	Back	104	5520	7.3	7.8	0.249	0.28
	20	A	Top	104	5520	7.3	7.8	0.51	0.57
	20	A	Top Tilt	104	5520	7.3	7.8	0.545	0.61
802.11n MCS0 1TX	40	A	Top Tilt	102	5510	7.25	7.8	0.494	0.56
802.11a 6 Mbps 2TX	20	A	Back	104	5520	7.45	7.8	0.247	0.27
	20	A	Top	136	5680	6.5	7.8	0.552	0.74
	20	A	Top Tilt	104	5520	7.45	7.8	0.523	0.57

11.15 WLAN 5.6 GHz SAR Test Results with Type Cover Accessory

Mode	BW (MHz)	Ant.	Position	Ch.	Freq. (MHz)	Avg. Pwr. (dBm)	Max. Pwr. (dBm)	Meas. 1g SAR (W/kg)	Reported 1g SAR (W/kg)
802.11a 6 Mbps 1TX	20	A	Top Tilt w/Type Cover	104	5520	7.3	7.8	0.534	0.60
802.11n MCS0 1TX	40	B	Top w/Type Cover	134	5670	6.75	7.8	1.19	1.52

11.16 WLAN 5.8 GHz Main Antenna (Path B) SAR Test Results

Mode	BW (MHz)	Ant.	Position	Ch.	Freq. (MHz)	Avg. Pwr. (dBm)	Max. Pwr. (dBm)	Meas. 1g SAR (W/kg)	Reported 1g SAR (W/kg)
802.11a 6 Mbps 1TX	20	B	Back	165	6825	7.05	7.8	0.327	0.39
	20	B	Top	149	5745	6.85	7.8	0.963	1.20
	20	B	Top	161	5805	7	7.8	0.97	1.17
	20	B	Top	165	5825	7.05	7.8	0.993	1.18
	20	B	Top Tilt	149	5745	6.85	7.8	0.872	1.09
	20	B	Top Tilt	161	5805	7	7.8	0.823	0.99
	20	B	Top Tilt	165	5825	7.05	7.8	0.826	0.98
802.11n MCS0 1TX	40	B	Top	151	5755	6.7	7.8	0.933	1.20
	40	B	Top	159	5795	6.8	7.8	0.913	1.15
802.11ac MCS0 1TX	80	B	Top	155	1775	6.6	6.8	0.956	1.00
802.11a 6 Mbps 2TX	20	B	Back	149	5745	6.9	7.8	0.349	0.43
	20	B	Top	149	5745	6.9	7.8	0.961	1.18
	20	B	Top	161	5805	6.9	7.8	0.934	1.15
	20	B	Top	165	5825	7.05	7.8	0.938	1.11
	20	B	Top Tilt	149	5745	6.9	7.8	0.901	1.11
	20	B	Top Tilt	161	5805	6.9	7.8	0.894	1.10
	20	B	Top Tilt	165	5825	7.05	7.8	0.83	0.99

11.17 WLAN 5.8 GHz Aux. Antenna (Path A) SAR Test Results

Mode	BW (MHz)	Ant.	Position	Ch.	Freq. (MHz)	Avg. Pwr. (dBm)	Max. Pwr. (dBm)	Meas. 1g SAR (W/kg)	Reported 1g SAR (W/kg)
802.11a 6 Mbps 1TX	20	A	Back	165	5825	7.1	7.8	0.195	0.23
	20	A	Top	165	5825	7.1	7.8	0.353	0.41
	20	A	Top Tilt	165	5825	7.1	7.8	0.388	0.46
802.11n MCS0 1TX	40	A	Top Tilt	159	5795	6.95	7.8	0.448	0.54
802.11a 6 Mbps 2TX	20	A	Back	149	5745	6.6	7.8	0.186	0.25
	20	A	Top	149	5745	6.6	7.8	0.448	0.59
	20	A	Top Tilt	165	5825	7.2	7.8	0.38	0.44

11.18 WLAN 5.8 GHz SAR Test Results with Type Cover Accessory

Mode	BW (MHz)	Ant.	Position	Ch.	Freq. (MHz)	Avg. Pwr. (dBm)	Max. Pwr. (dBm)	Meas. 1g SAR (W/kg)	Reported 1g SAR (W/kg)
802.11a 6 Mbps 1TX	20	A	Top Tilt w/Type Cover	165	5825	7.1	7.8	0.389	0.46
802.11n MCS0 1TX	40	B	Top w/Type Cover	151	5755	6.7	7.8	0.949	1.22 (Repeat)

11.19 Bluetooth SAR Test Results

Bluetooth SAR tests were performed to simplify simultaneous transmission SAR evaluation.

Mode	Ant.	Position	Ch.	Freq. (MHz)	Avg. Pwr. (dBm)	Max. Pwr. (dBm)	Meas. 1g SAR (W/kg)	Reported 1g SAR (W/kg)
BT 1-DH5	B	Top	39	2440	3.65	4	0.0187	0.02
	B	Top Tilt	39	2440	3.65	4	0.0206	0.02
	B	Back	39	2440	3.65	4	0.176	0.19
BTLE	B	Top	19	2440	3.2	4	0.026	0.03
	B	Top Tilt	19	2440	3.2	4	0.0262	0.03
	B	Back	19	2440	3.2	4	0.179	0.22

12 Repeated SAR Measurements

SAR measurements are repeated according to the rules of **KDB 865664 D01 v01r03 Section 2.8.1 SAR measurement variability**. SAR measurement variability must be assessed for each frequency band.

- 1) Repeated measurement is not required when the original highest measured SAR is < 0.80 W/kg; steps 2) through 4) do not apply.
- 2) When the original highest measured SAR is ≥ 0.80 W/kg, repeat that measurement once.
- 3) Perform a second repeated measurement only if the ratio of largest to smallest SAR for the original and first repeated measurements is > 1.20 or when the original or repeated measurement is ≥ 1.45 W/kg (~10% from the 1-g SAR limit).
- 4) Perform a third repeated measurement only if the original, first or second repeated measurement is ≥ 1.5 W/kg and the ratio of largest to smallest SAR for the original, first and second repeated measurements is > 1.20 .

12.1 SAR Variability Repeat Measurements

Band (GHz)	Mode	BW (MHz)	Ant.	Position	Ch.	Freq. (MHz)	Orig. 1-g SAR Meas. (W/kg)	Repeat 1-g SAR Meas. (W/kg)	Repeat Reported 1-g SAR (W/kg)
2.4	802.11n 1TX	20	A	Back	1	2412	0.774	0.758	1.02
5.2	802.11a 1TX	20	B	Top	48	5240	1.32	1.33	1.36 (Plot 3)
5.3	802.11a 2TX	20	B	Top	60	5300	1.29	1.18	1.29
5.6	802.11n 1TX	40	B	Top	134	5670	1.21	1.19	1.52
5.8	802.11n 1TX	40	B	Top w/Type Cover	151	5755	0.949	0.974	1.25 (Plot 6)

13 Simultaneous Transmission Evaluation

(KDB 447498 D01 v05r02) Simultaneous transmission SAR must be considered for all operating configurations and exposure conditions in which separate antennas can transmit signals at the same time. All such simultaneous transmission configurations must be shown to be compliant, which can be done in any of the following three ways:

1. The sum of the highest standalone *Reported SAR* values from each antenna in the configuration is less than the SAR limit.
2. The SAR to peak location separation ratio is ≤ 0.04 . This ratio is calculated as:

$$\frac{(Reported\ SAR^{Antenna1} + Reported\ SAR^{Antenna2})^{1.5}}{Distance\ Between\ Antenna\ 1\ and\ Antenna\ 2\ peak\ SAR\ locations\ in\ mm}$$

3. When neither 1 nor 2 suffice, simultaneous transmission must be measured either by volume scans or multiple zoom scans so that each applicable air interface is tested at all antenna locations in question. The separate scans from the simultaneously transmitting antennas are then summed together point by point to obtain the simultaneous transmission measured SAR value. The reported simultaneous transmission SAR value must be less than the limit.

13.1 Important Standalone SAR values for Simultaneous Transmission Evaluation

Exposure Condition	Test Position	Air Interface	Ch.	Freq. (MHz)	Antenna	Peak SAR Location Coordinates		Reported SAR (W/kg)
						X	Y	
Body	Back	802.11b	1	2412	A	NA	NA	1.04
	Top Tilt	802.11n	54	5270	A	NA	NA	0.67
	Back	BTLE	39	2440	B	NA	NA	0.22
	Top Tilt	BTLE	19	2440	B	NA	NA	0.03

*Main Antenna (Chain B) WLAN measurements are not noted since it cannot transmit WLAN at the same time as Bluetooth.

13.2 Simultaneous Transmission Evaluation Results

13.2.1 Bluetooth (Antenna B) + WLAN (Antenna A) Simultaneous Transmission Analysis

Exposure Condition	Test Position	Antennas + Air Interfaces Used		Peak Location Sep. Distance (mm)	Simultaneous Transmission Evaluation Method Used	Result
		Main Antenna (Chain B)	Aux. Antenna (Chain A)			
Body	Back	Bluetooth	802.11b	N/A	Standalone Sum	1.26
	Top Tilt	Bluetooth	802.11a	N/A	Standalone Sum	0.7

14 SAR System Verification

System Verifications were performed in accordance with **IEEE 1528-2013** and **KDB 865664 D01 v01r03**. Verifications were performed for each frequency band and within the valid range of each probe calibration point required for testing the device. The same SAR probe(s) and tissue-equivalent liquid combinations used with each SAR system for system verification were used for device testing. Verifications were performed before each series of SAR measurements using the same calibration point and tissue-equivalent medium and every three days thereafter when necessary.

The test setup diagram is shown below. A CW signal is created by a signal generator and fed through a power amplifier with directional coupler outputs. The forward output power is adjusted to 20 dBm while the coupled output power is normalized to 0dB for easy monitoring. When the forward power is attached to the dipole, the power is then adjusted if necessary so that the coupled channel again reads 0 dB on the power meter. Tissue-simulating liquid depth in the phantom is maintained to be at least 15 cm for frequencies below 3 GHz and 10 cm for frequencies above 5 GHz.

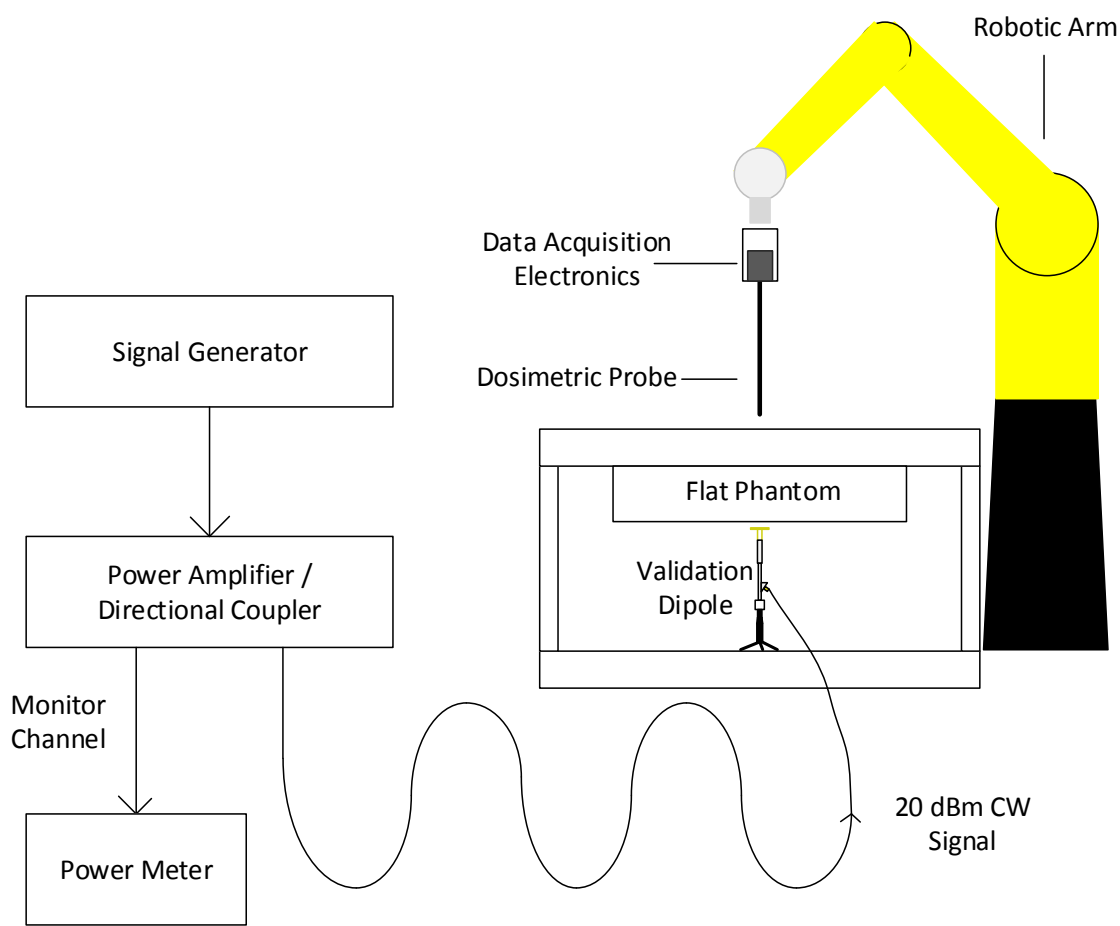

System Verification Setup

14.1 SAR System Verification Results

All verifications are performed with a 100 mW (20 dBm) input to the dipole. The resultant measured SAR is normalized to 1 W (30 dBm) for comparison to calibrated dipole targets. All normalized SAR system verification results were within 10% of the respective dipole target values.

Date	Tissue-Sim. Liquid	Dipole	Freq. (MHz)	Meas. 1-g SAR (W/kg)	Norm. 1-g SAR (W/kg)	Dipole Target 1-g SAR (W/kg)	Deviation from Target 1-g SAR (%)
1/21/2015	MSL	D2450V2_916	2450	5.06	50.6	51.7	-2.13
1/29/2015	MSL	D2450V2_916	2450	5.29	52.9	51.7	2.32 (Plot 7)
1/14/2015	MBBL	D5GHzV2_1158	5200	7.75	77.5	76.7	1.04
1/18/2015	MBBL	D5GHzV2_1158	5200	7.77	77.7	76.7	1.30
1/30/2015	MBBL	D5GHzV2_1158	5200	7.85	78.5	76.7	2.35 (Plot 8)
1/14/2015	MBBL	D5GHzV2_1158	5600	8.06	80.6	83.1	-3.01 (Plot 9)
1/18/2015	MBBL	D5GHzV2_1158	5600	8.42	84.2	83.1	1.32
1/14/2015	MBBL	D5GHzV2_1158	5800	7.25	72.5	76.3	-4.98 (Plot 10)
1/18/2015	MBBL	D5GHzV2_1158	5800	7.34	73.4	76.3	-3.80

15 Tissue-Simulating Liquid Verification

(KDB 854664 D01 v01r03 Section 2.4) The tissue dielectric parameters of tissue-equivalent media used for SAR measurements must be characterized within a temperature range of 18°C to 25°C, measured with calibrated instruments and apparatuses, such as network analyzers and temperature probes. The temperature of the tissue-equivalent medium during SAR measurement must also be within 18°C to 25°C and within $\pm 2^\circ\text{C}$ of the temperature when the tissue parameters are characterized. The tissue dielectric measurement system must be calibrated before use. The dielectric parameters must be measured before the tissue-equivalent medium is used in a series of SAR measurements. The parameters should be re-measured after each 3 – 4 days of use; or earlier if the dielectric parameters can become out of tolerance; for example, when the parameters are marginal at the beginning of the measurement series.

The target parameters for the tissue-simulating liquids are obtained from the following table from KDB 865664 D01:

Target Frequency (MHz)	Head		Body	
	ϵ_r	σ (S/m)	ϵ_r	σ (S/m)
150	52.3	0.76	61.9	0.80
300	45.3	0.87	58.2	0.92
450	43.5	0.87	56.7	0.94
835	41.5	0.90	55.2	0.97
900	41.5	0.97	55.0	1.05
915	41.5	0.98	55.0	1.06
1450	40.5	1.20	54.0	1.30
1610	40.3	1.29	53.8	1.40
1800 – 2000	40.0	1.40	53.3	1.52
2450	39.2	1.80	52.7	1.95
3000	38.5	2.40	52.0	2.73
5800	35.3	5.27	48.2	6.00

(ϵ_r = relative permittivity, σ = conductivity and $\rho = 1000 \text{ kg/m}^3$)

15.1 Tissue-Simulating Liquid Ingredients and Maintenance

The Tissue-simulating liquids were manufactured by SPEAG. The following information on the maintenance of

MSL 2450 Ingredients: Water, DGBE

MBBL 3500 – 5800 Ingredients: Water, Mineral Oil, Emulsifiers, Sodium Chloride

DGBE BASED LIQUIDS

DGBE is easily dissolved in water. Given a DGBE-water mixture, mainly water will evaporate, however DGBE will evaporate to a smaller percentage. For the frequency liquids around 2.5 GHz, no NaCl is contained and should therefore not be added for any corrections.

Evaporated water can be replaced and will mainly increase the permittivity, and to a small extent the conductivity, typically as follows:

HSLxxxxV2: permittivity 0.8 to 1.0 per % of water, conductivity 0 to 0.1 per % of water

MSLxxxxV2: permittivity 0.8 per % of water, conductivity 0 to 0.01 per % of water

OIL BASED LIQUIDS

Oil based liquids are an emulsion of a complex mixture of ingredients. Their appearance is yellow or brown transparent or slightly opaque / milky in most cases. Some older liquids may show a non-transparent upper zone with a creamy appearance after some time without stirring. Before using or handling the liquid, it must therefore be stirred to become entirely homogeneous. An opaque appearance is possible but will not influence the dielectric parameters if it is homogeneous during the measurement at the probe surface.

Evaporated water can be replaced and will increase the permittivity, and to a smaller extent the conductivity.

The **sensitivities to water addition** (% parameter increase per weight% water added) of oil based SPEAG broadband tissue simulating liquids at the frequencies of interest are typically in the following range:

HBBL3500-5800V5	at 3.5 GHz:	permittivity 0.79, conductivity 0.14
	at 5.5 GHz:	permittivity 0.83, conductivity 0.41

MBBL3500-5800V5	at 3.5 GHz:	permittivity 0.44, conductivity 0.00
	at 5.5 GHz:	permittivity 0.48, conductivity 0.18

The **temperature gradients** shall be observed especially during conductivity measurement:

HBBL3500-5800V5	at 3.5 GHz:	permittivity -0.07, conductivity -0.43 %/°C
	at 5.5 GHz:	permittivity -0.23, conductivity -0.96 %/°C

MBBL3500-5800V5	at 3.5 GHz:	permittivity -0.35, conductivity -1.14 %/°C
	at 5.5 GHz:	permittivity -0.08, conductivity -1.52 %/°C

15.2 Tissue-Simulating Liquid Measurements

Date	Tissue-Simulating Liquid	Freq. (MHz)	Rel. Perm. ϵ'_r	Target ϵ'_r	ϵ'_r Dev. %	Cond. σ (S/m)	Target σ (S/m)	σ Dev. %
1/21/2015	MSL 2450 130710-1 22.6 °C	2412	50.34	52.75	-4.57	1.907	1.91	-0.35
		2437	50.23	52.72	-4.72	1.94	1.94	0.13
		2450	50.2	52.70	-4.74	1.957	1.95	0.36
		2462	50.15	52.68	-4.81	1.971	1.97	0.20
1/29/2015	MSL 2450 130710-1 23 °C	2412	51.01	52.75	-3.30	1.861	1.91	-2.75
		2437	50.9	52.72	-3.45	1.896	1.94	-2.15
		2450	50.87	52.70	-3.47	1.914	1.95	-1.85
		2462	50.82	52.68	-3.54	1.931	1.97	-1.83
1/14/2015	MBBL 3500-5800 130705-2 22.3 °C	5180	46.78	49.04	-4.61	5.397	5.28	2.29
		5200	46.73	49.01	-4.66	5.428	5.30	2.43
		5260	46.62	48.93	-4.73	5.508	5.37	2.58
		5320	46.49	48.85	-4.83	5.595	5.44	2.86
1/14/2015	MBBL 3500-5800 130705-1 22.3 °C	5500	46.91	48.61	-3.49	5.634	5.65	-0.28
		5600	46.75	48.47	-3.55	5.761	5.77	-0.09
		5700	46.59	48.34	-3.61	5.887	5.88	0.06
		5800	46.43	48.20	-3.67	6.015	6.00	0.25
1/18/2015	MBBL 3500-5800 130705-2 22.5 °C	5180	47.1	49.04	-3.96	5.341	5.28	1.23
		5200	47.12	49.01	-3.86	5.375	5.30	1.43
		5260	46.94	48.93	-4.07	5.448	5.37	1.46
		5320	46.8	48.85	-4.20	5.529	5.44	1.65
1/18/2015	MBBL 3500-5800 130705-1 21.8 °C	5500	47.22	48.61	-2.85	5.659	5.65	0.17
		5600	47.03	48.47	-2.97	5.798	5.77	0.55
		5700	46.85	48.34	-3.07	5.94	5.88	0.97
		5800	46.67	48.20	-3.17	6.084	6.00	1.40
		5825	46.62	48.17	-3.21	6.15	6.03	2.00
1/30/2015	MBBL 3500-5800 130705-1 21.4 °C	5180	49.49	49.04	0.91	5.303	5.28	0.51
		5200	49.45	49.01	0.89	5.329	5.30	0.54
		5260	49.33	48.93	0.81	5.419	5.37	0.92
		5320	49.20	48.85	0.71	5.49	5.44	0.93

16 System Specification

16.1 SPEAG DASY5 SYSTEM

DASY 5 system performing SAR testing contains the following items, which are illustrated in the figure below.

- 6-axis robot (model: TX90XL) with controller and teach pendant.
- Dosimetric E-field probe.
- Light beam unit which allows automatic “tooling” of the probe.
- The electro-optical convertor (EOC) which is mounted on the robot arm.
- The data acquisition electronics (DAE).
- Elliptical Phantom
- Device holder.
- Remote control.
- PC.
- DASY5 software.
- Validation dipole.

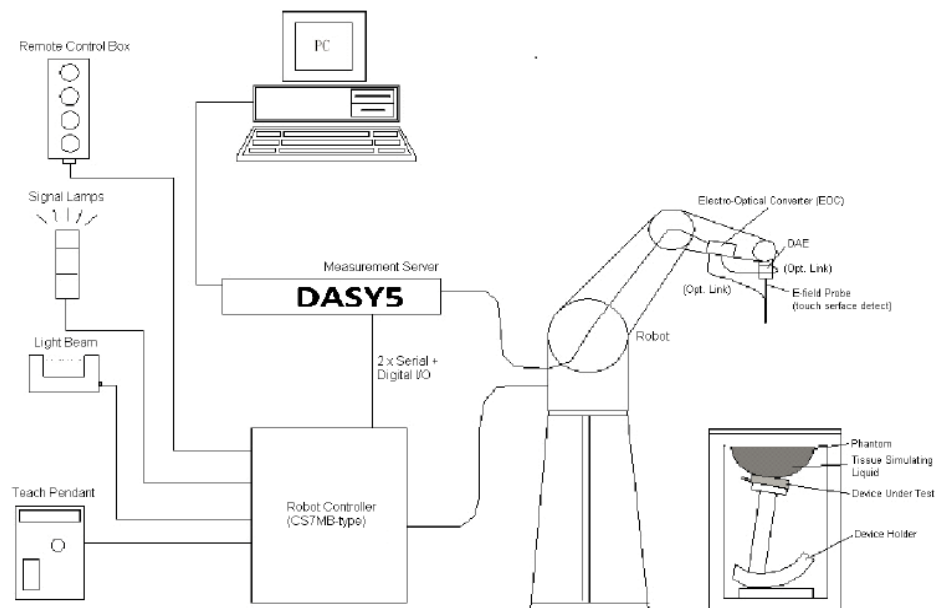

DASY5 System Setup

17 Measurement Uncertainty

KDB 865664 D01 v01r03 section 2.8.2 says:

SAR measurement uncertainty analysis is required in SAR reports only when the highest measured SAR in a frequency band is ≥ 1.5 W/kg for 1-g SAR.

The highest **measured** 1-g SAR in this report is 1.33 W/kg. Therefore, SAR measurement uncertainty analysis is not required for this report.

18 Appendices

The following are contained in the attached appendices:

- Highest SAR Test and SAR System Verification Plots
- SAR Test Setup Photos
- Calibration Report Documents for:
 - Validation Dipole D2450V2-916_Jul14
 - Validation Dipole D5GHzV2-1158_Jul14
 - Dosimetric Probe EX3-DV4-3939_Jul14
 - Dosimetric Probe EX3-DV4-3940_Jul14

End of Test Report