



A D T

FCC TEST REPORT

REPORT NO.: RF130718D08 R1

MODEL NO.: 1598

FCC ID: C3K1598

RECEIVED: Jul. 18, 2013

TESTED: Jul. 22 ~ 24, 2013

ISSUED: Aug. 7, 2013

APPLICANT: MICROSOFT CORPORATION

ADDRESS: ONE MICROSOFT WAY REDMOND, WA
98052-6399, U.S.A

ISSUED BY: Bureau Veritas Consumer Products Services (H.K.)
Ltd., Taoyuan Branch

LAB LOCATION: No. 47, 14th Ling, Chia Pau Vil., Lin Kou Dist., New
Taipei City, Taiwan (R.O.C.)

This report should not be used by the client to claim product certification, approval, or endorsement by TAF or any government agencies.



This report is for your exclusive use. Any copying or replication of this report to or for any other person or entity, or use of our name or trademark, is permitted only with our prior written permission. This report sets forth our findings solely with respect to the test samples identified herein. The results set forth in this report are not indicative or representative of the quality or characteristics of the lot from which a test sample was taken or any similar or identical product unless specifically and expressly noted. Our report includes all of the tests requested by you and the results thereof based upon the information that you provided to us. You have 60 days from date of issuance of this report to notify us of any material error or omission caused by our negligence, provided, however, that such notice shall be in writing and shall specifically address the issue you wish to raise. A failure to raise such issue within the prescribed time shall constitute your unqualified acceptance of the completeness of this report, the tests conducted and the correctness of the report contents. Unless specific mention, the uncertainty of measurement has been explicitly taken into account to declare the compliance or non-compliance to the specification.



Table of Contents

RELEASE CONTROL RECORD.....	4
1. CERTIFICATION	5
2. SUMMARY OF TEST RESULTS.....	6
2.1 MEASUREMENT UNCERTAINTY	6
3. GENERAL INFORMATION	7
3.1 GENERAL DESCRIPTION OF EUT.....	7
3.2 DESCRIPTION OF TEST MODES.....	8
3.2.1 TEST MODE APPLICABILITY AND TESTED CHANNEL DETAIL	9
3.3 DESCRIPTION OF SUPPORT UNITS	12
3.3.1 CONFIGURATION OF SYSTEM UNDER TEST	12
3.4 GENERAL DESCRIPTION OF APPLIED STANDARDS	13
4. TEST TYPES AND RESULTS	14
4.1 RADIATED EMISSION AND BANDEDGE MEASUREMENT.....	14
4.1.1 LIMITS OF RADIATED EMISSION AND BANDEDGE MEASUREMENT	14
4.1.2 TEST INSTRUMENTS	15
4.1.3 TEST PROCEDURES.....	16
4.1.4 DEVIATION FROM TEST STANDARD	16
4.1.5 TEST SETUP	17
4.1.6 EUT OPERATING CONDITIONS.....	17
4.1.7 TEST RESULTS.....	18
4.2 CONDUCTED EMISSION MEASUREMENT	42
4.2.1 LIMITS OF CONDUCTED EMISSION MEASUREMENT.....	42
4.2.2 TEST INSTRUMENTS	42
4.2.3 TEST PROCEDURES.....	43
4.2.4 DEVIATION FROM TEST STANDARD	43
4.2.5 TEST SETUP	44
4.2.6 EUT OPERATING CONDITIONS.....	44
4.2.7 TEST RESULTS.....	45
4.3 NUMBER OF HOPPING FREQUENCY USED	47
4.3.1 LIMIT OF HOPPING FREQUENCY USED	47
4.3.2 TEST SETUP	47
4.3.3 TEST INSTRUMENTS	47
4.3.4 TEST PROCEDURES.....	47
4.3.5 DEVIATION FROM TEST STANDARD	47
4.3.6 TEST RESULTS.....	47
4.4 DWELL TIME ON EACH CHANNEL	49
4.4.1 LIMIT OF DWELL TIME USED.....	49
4.4.2 TEST SETUP	49
4.4.3 TEST INSTRUMENTS	49
4.4.4 TEST PROCEDURES.....	49
4.4.5 DEVIATION FROM TEST STANDARD	49
4.4.6 TEST RESULTS.....	50
4.5 CHANNEL BANDWIDTH.....	51
4.5.1 LIMITS OF CHANNEL BANDWIDTH.....	51



4.5.2	TEST SETUP	51
4.5.3	TEST INSTRUMENTS	51
4.5.4	TEST PROCEDURE	51
4.5.5	DEVIATION FROM TEST STANDARD	51
4.5.6	EUT OPERATING CONDITION	51
4.5.7	TEST RESULTS	52
4.6	HOPPING CHANNEL SEPARATION	53
4.6.1	LIMIT OF HOPPING CHANNEL SEPARATION	53
4.6.2	TEST SETUP	53
4.6.3	TEST INSTRUMENTS	53
4.6.4	TEST PROCEDURES	53
4.6.5	DEVIATION FROM TEST STANDARD	53
4.6.6	TEST RESULTS	54
4.7	MAXIMUM OUTPUT POWER	55
4.7.1	LIMITS OF MAXIMUM OUTPUT POWER MEASUREMENT	55
4.7.2	TEST SETUP	55
4.7.3	TEST INSTRUMENTS	55
4.7.4	TEST PROCEDURES	55
4.7.5	DEVIATION FROM TEST STANDARD	55
4.7.6	EUT OPERATING CONDITION	55
4.7.7	TEST RESULTS	56
4.8	CONDUCTED OUT OF BAND EMISSION MEASUREMENT	57
4.8.1	LIMITS OF CONDUCTED OUT OF BAND EMISSION MEASUREMENT	57
4.8.2	TEST INSTRUMENTS	57
4.8.3	TEST PROCEDURE	57
4.8.4	DEVIATION FROM TEST STANDARD	57
4.8.5	EUT OPERATING CONDITION	57
4.8.6	TEST RESULTS	57
5.	PHOTOGRAPHS OF THE TEST CONFIGURATION	59
6.	INFORMATION ON THE TESTING LABORATORIES	60
7.	APPENDIX A - MODIFICATIONS RECORDERS FOR ENGINEERING CHANGES TO THE EUT BY THE LAB	61



A D T

RELEASE CONTROL RECORD

ISSUE NO.	REASON FOR CHANGE	DATE ISSUED
RF130718D08	Original release	Jul. 30, 2013
RF130718D08 R1	Modify on page 50 for item 4.4.6 DH5 Length of transmission time Modify on page 52 for item 4.5.7 Chanel 0 20dB BANDWIDTH Modify on page 54 for item 4.6.6 Chanel 0 20dB BANDWIDTH & Minimum Limit	Aug. 7, 2013

1. CERTIFICATION

PRODUCT: Wireless Adapter
MODEL NO.: 1598
BRAND: Microsoft®
APPLICANT: MICROSOFT CORPORATION
TESTED: Jul. 22 ~ 24, 2013
TEST SAMPLE: ENGINEERING SAMPLE
STANDARDS: **FCC Part 15, Subpart C (Section 15.247)**
ANSI C63.10-2009

The above equipment has been tested by **Bureau Veritas Consumer Products Services (H.K.) Ltd., Taoyuan Branch**, and found compliance with the requirement of the above standards. The test record, data evaluation & Equipment Under Test (EUT) configurations represented herein are true and accurate accounts of the measurements of the sample's EMC characteristics under the conditions specified in this report.

PREPARED BY : Jessica Cheng , **DATE:** Aug. 7, 2013
(Jessica Cheng / Specialist)

APPROVED BY : Ken Liu , **DATE:** Aug. 7, 2013
(Ken Liu / Senior Manager)

2. SUMMARY OF TEST RESULTS

The EUT has been tested according to the following specifications:

APPLIED STANDARD: FCC Part 15, Subpart C			
STANDARD SECTION	TEST TYPE AND LIMIT	RESULT	REMARK
15.207	AC Power Conducted Emission	PASS	Meet the requirement of limit. Minimum passing margin is -11.74dB at 0.15000MHz.
15.247(a)(1) (iii)	Number of Hopping Frequency Used	PASS	Meet the requirement of limit.
15.247(a)(1) (iii)	Dwell Time on Each Channel	PASS	Meet the requirement of limit.
15.247(a)(1)	1. Hopping Channel Separation 2. Spectrum Bandwidth of a Frequency Hopping Sequence Spread Spectrum System	PASS	Meet the requirement of limit.
15.247(b)	Maximum Peak Output Power	PASS	Meet the requirement of limit.
15.247(d)	Transmitter Radiated Emissions	PASS	Meet the requirement of limit. Minimum passing margin is -6.1dB at 93.05MHz.
15.247(d)	Band Edge Measurement	PASS	Meet the requirement of limit.
15.203	Antenna Requirement	PASS	No antenna connector is used.

NOTE: If The Frequency Hopping System operating in 2400-2483.5MHz band and the output power less than 125mW. The hopping channel carrier frequencies separated by a minimum of 25kHz or two-thirds of the 20dB bandwidth of hopping channel whichever is greater.

2.1 MEASUREMENT UNCERTAINTY

Where relevant, the following measurement uncertainty levels have been estimated for tests performed on the EUT as specified in CISPR 16-4-2:

Measurement	Frequency	Uncertainty
Conducted emissions	150kHz ~ 30MHz	2.41 dB
Radiated emissions	30MHz ~ 1GHz	4.30 dB
	Above 1GHz	3.36 dB

This uncertainty represents an expanded uncertainty expressed at approximately the 95% confidence level using a coverage factor of k=2.

3. GENERAL INFORMATION

3.1 GENERAL DESCRIPTION OF EUT

EUT	Wireless Adapter
MODEL NO.	1598
POWER SUPPLY	2.4Vdc (from battery) or 5.0Vdc (from host equipment)
MODULATION TYPE	GFSK
MODULATION TECHNOLOGY	FHSS
TRANSFER RATE	723.2Kbps
OPERATING FREQUENCY	2402 ~ 2480MHz
NUMBER OF CHANNEL	79
MAX. OUTPUT POWER	0.5mW
ANTENNA TYPE	Loop antenna with -1.35dBi gain
ANTENNA CONNECTOR	NA
I/O PORTS	Micro USB
DATA CABLE	0.5m Micro USB to USB cable.
ACCESSORY DEVICES	NA

NOTE:

1. The EUT is a Wireless Adapter with Micro USB interface.
2. The EUT has serial samples, which are defined as their serial numbers as follows:

Model No.	Serial no.
1598	DVT000137C32754, DVT000025C32754, DVT000143C32754 DVT000407C32754

3. USB cable is for battery charging only. The EUT will not initiate communication with PC through this cable.
4. The above EUT information is declared by manufacturer and for more detailed features description, please refer to the manufacturer's specifications or User's Manual.

3.2 DESCRIPTION OF TEST MODES

79 channels are provided to this EUT:

CHANNEL	FREQ. (MHz)	CHANNEL	FREQ. (MHz)	CHANNEL	FREQ. (MHz)	CHANNEL	FREQ. (MHz)
0	2402	20	2422	40	2442	60	2462
1	2403	21	2423	41	2443	61	2463
2	2404	22	2424	42	2444	62	2464
3	2405	23	2425	43	2445	63	2465
4	2406	24	2426	44	2446	64	2466
5	2407	25	2427	45	2447	65	2467
6	2408	26	2428	46	2448	66	2468
7	2409	27	2429	47	2449	67	2469
8	2410	28	2430	48	2450	68	2470
9	2411	29	2431	49	2451	69	2471
10	2412	30	2432	50	2452	70	2472
11	2413	31	2433	51	2453	71	2473
12	2414	32	2434	52	2454	72	2474
13	2415	33	2435	53	2455	73	2475
14	2416	34	2436	54	2456	74	2476
15	2417	35	2437	55	2457	75	2477
16	2418	36	2438	56	2458	76	2478
17	2419	37	2439	57	2459	77	2479
18	2420	38	2440	58	2460	78	2480
19	2421	39	2441	59	2461		



3.2.1 TEST MODE APPLICABILITY AND TESTED CHANNEL DETAIL

EUT CONFIGURE MODE	APPLICABLE TO					DESCRIPTION
	RE [≥] 1G	RE<1G	PLC	APCM	OB	
A	√	√	√	√	√	Operating + Charging (EUT with Surface)
B	√	√	Note	-	-	Operating (EUT only)

Where **RE[≥]1G**: Radiated Emission above 1GHz **RE<1G**: Radiated Emission below 1GHz
PLC: Power Line Conducted Emission **APCM**: Antenna Port Conducted Measurement
OB: Conducted Out-Band Emission Measurement

NOTE: "-" means no effect.

NOTE: No need to concern of Conducted Emission due to the EUT is powered by batteries.

RADIATED EMISSION TEST (ABOVE 1 GHz):

- Pre-Scan has been conducted to determine the worst-case mode from all possible combinations between available modulations, antenna ports (if EUT with antenna diversity architecture) and packet type.
- Following channel(s) was (were) selected for the final test as listed below.

EUT CONFIGURE MODE	SERIAL NO.	AVAILABLE CHANNEL	TESTED CHANNEL	MODULATION TECHNOLOGY	MODULATION TYPE	PACKET TYPE
A & B	DVT000137C32754, DVT000025C32754, DVT000143C32754	0 to 78	0, 39, 78	FHSS	GFSK	DH5

RADIATED EMISSION TEST (BELOW 1 GHz):

- Pre-Scan has been conducted to determine the worst-case mode from all possible combinations between available modulations, antenna ports (if EUT with antenna diversity architecture) and packet type.
- Following channel(s) was (were) selected for the final test as listed below.

EUT CONFIGURE MODE	SERIAL NO.	AVAILABLE CHANNEL	TESTED CHANNEL	MODULATION TECHNOLOGY	MODULATION TYPE	PACKET TYPE
A & B	DVT000137C32754, DVT000025C32754, DVT000143C32754	0 to 78	78	FHSS	GFSK	DH5



A D T

POWER LINE CONDUCTED EMISSION TEST:

- Pre-Scan has been conducted to determine the worst-case mode from all possible combinations between available modulations, antenna ports (if EUT with antenna diversity architecture) and packet types.
- Following channel(s) was (were) selected for the final test as listed below.

EUT CONFIGURE MODE	SERIAL NO.	AVAILABLE CHANNEL	TESTED CHANNEL	MODULATION TECHNOLOGY	MODULATION TYPE	PACKET TYPE
A	DVT000407C32754	0 to 78	78	FHSS	GFSK	DH5

BANDEDGE MEASUREMENT:

- Pre-Scan has been conducted to determine the worst-case mode from all possible combinations between available modulations, antenna ports (if EUT with antenna diversity architecture), and packet types.
- Following channel(s) was (were) selected for the final test as listed below.

EUT CONFIGURE MODE	SERIAL NO.	AVAILABLE CHANNEL	TESTED CHANNEL	MODULATION TECHNOLOGY	MODULATION TYPE	PACKET TYPE
A & B	DVT000137C32754	0 to 78	0, 78	FHSS	GFSK	DH5

ANTENNA PORT CONDUCTED MEASUREMENT:

- This item includes all test value of each mode, but only includes spectrum plot of worst value of each mode.
- Pre-Scan has been conducted to determine the worst-case mode from all possible combinations between available modulations, antenna ports (if EUT with antenna diversity architecture), and packet types.
- Following channel(s) was (were) selected for the final test as listed below.

EUT CONFIGURE MODE	SERIAL NO.	AVAILABLE CHANNEL	TESTED CHANNEL	MODULATION TECHNOLOGY	MODULATION TYPE	PACKET TYPE
A & B	DVT000137C32754	0 to 78	0, 39, 78	FHSS	GFSK	DH5



A D T

TEST CONDITION:

APPLICABLE TO	EUT CONFIGURE MODE	ENVIRONMENTAL CONDITIONS	INPUT POWER	TESTED BY
RE ³ 1G	A	22deg. C, 76% RH	120Vac, 60Hz (System)	Saxon Lee
	B	22deg. C, 76% RH	2.4Vdc	Saxon Lee
RE<1G	A	22deg. C, 76% RH	120Vac, 60Hz (System)	Saxon Lee
	B	22deg. C, 76% RH	2.4Vdc	Saxon Lee
PLC	A	25deg. C, 75% RH	120Vac, 60Hz (System)	Dalen Dai
APCM	A	27deg. C, 75% RH	120Vac, 60Hz (System)	Chad Lee

3.3 DESCRIPTION OF SUPPORT UNITS

The EUT has been tested as an independent unit together with other necessary accessories or support units. The following support units or accessories were used to form a representative test configuration during the tests.

NO.	PRODUCT	BRAND	MODEL NO.	SERIAL NO.	FCC ID
1	Surface	Microsoft	1514	N/A	C3K1514
2	Adapter	Microsoft	1536	N/A	N/A

NO.	SIGNAL CABLE DESCRIPTION OF THE ABOVE SUPPORT UNITS
1	N/A
2	AC I/P: 100-240V, 50-60Hz, 13A (2 Pin) DC O/P:12V, 3.6A; 5V, 10A AC cable 0.5 m ;DC cable 1.5 m

NOTE: The supports 1-2 were provided by client.

3.3.1 CONFIGURATION OF SYSTEM UNDER TEST

FOR MODE A:

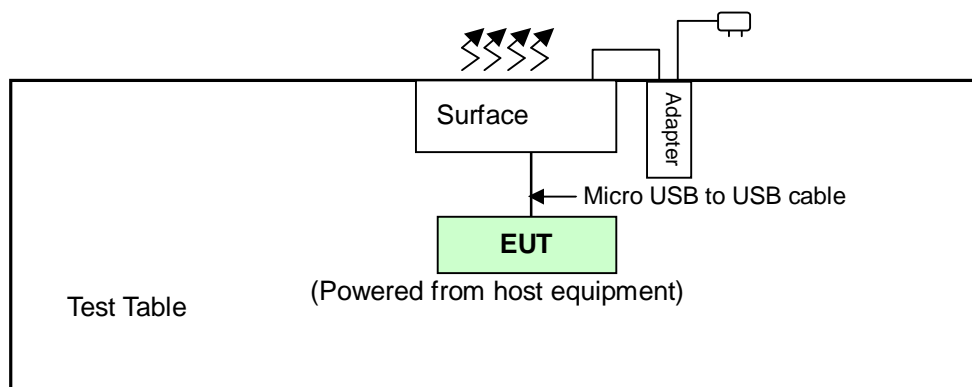

FOR MODE B:

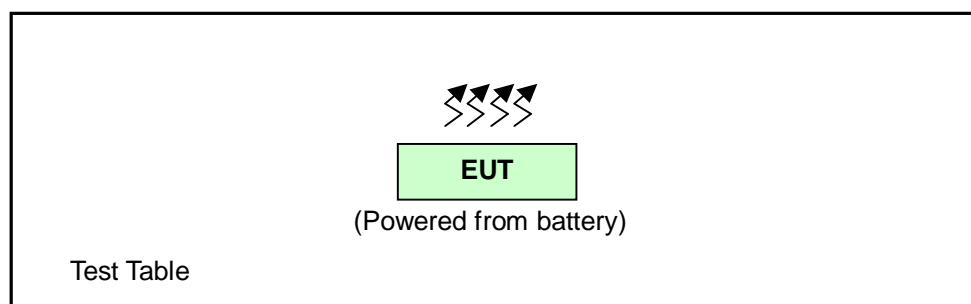



A D T

3.4 GENERAL DESCRIPTION OF APPLIED STANDARDS

The EUT is a RF Product. According to the specifications of the manufacturer, it must comply with the requirements of the following standards:

FCC Part 15, Subpart C. (15.247)

ANSI C63.10-2009

All test items have been performed and recorded as per the above standards.



4. TEST TYPES AND RESULTS

4.1 RADIATED EMISSION AND BANDEDGE MEASUREMENT

4.1.1 LIMITS OF RADIATED EMISSION AND BANDEDGE MEASUREMENT

Radiated emissions which fall in the restricted bands must comply with the radiated emission limits specified as below table. Other emissions shall be at least 20dB below the highest level of the desired power:

FREQUENCIES (MHz)	FIELD STRENGTH (microvolts/meter)	MEASUREMENT DISTANCE (meters)
0.009 ~ 0.490	2400/F(kHz)	300
0.490 ~ 1.705	24000/F(kHz)	30
1.705 ~ 30.0	30	30
30 ~ 88	100	3
88 ~ 216	150	3
216 ~ 960	200	3
Above 960	500	3

NOTE:

1. The lower limit shall apply at the transition frequencies.
2. Emission level (dBuV/m) = 20 log Emission level (uV/m).
3. For frequencies above 1000MHz, the field strength limits are based on average detector, however, the peak field strength of any emission shall not exceed the maximum permitted average limits, specified above by more than 20dB under any condition of modulation.



4.1.2 TEST INSTRUMENTS

DESCRIPTION & MANUFACTURER	MODEL NO.	SERIAL NO.	CALIBRATED DATE	CALIBRATED UNTIL
HP Preamplifier	8447D	2432A03504	Feb. 26, 2013	Feb. 25, 2014
HP Preamplifier	8449B	3008A01201	Feb. 26, 2013	Feb. 25, 2014
Agilent TEST RECEIVER	N9038A	MY51210129	Jan. 03, 2013	Jan. 02, 2014
Schwarzbeck Antenna	VULB 9168	137	Mar. 20, 2013	Mar. 19, 2014
Schwarzbeck Antenna	VHBA 9123	480	May 29, 2013	May 28, 2014
ADT. Turn Table	TT100	0306	NA	NA
ADT. Tower	AT100	0306	NA	NA
Software	ADT_Radiated_V 7.6.15.9.2	NA	NA	NA
SUHNER RF cable	SF102	CABLE-CH6	Aug. 19, 2012	Aug. 18, 2013
Schwarzbeck Horn Antenna	BBHA 9120-D1	D130	May 13, 2013	May 12, 2014
ROHDE & SCHWARZ Spectrum Analyzer	FSP 40	100036	May. 17, 2013	May. 16, 2014
Anritsu Power Sensor	MA2411B	0738404	Apr. 24, 2013	Apr. 23, 2014
Anritsu Power Meter	ML2495A	0842014	Apr. 25, 2013	Apr. 24, 2014

- NOTE:** 1. The calibration interval of the above test instruments is 12/24 months. And the calibrations are traceable to NML/ROC and NIST/USA.
2. The horn antenna and HP preamplifier (model: 8449B) are used only for the measurement of emission frequency above 1GHz if tested.
3. The test was performed in Chamber No. 6.
4. The Industry Canada Reference No. IC 7450E-6.
5. The FCC Site Registration No. is 447212.

4.1.3 TEST PROCEDURES

- a. The EUT was placed on the top of a rotating table 0.8 meters above the ground at a 3 meter semi-anechoic chamber. The table was rotated 360 degrees to determine the position of the highest radiation.
- b. The EUT was set 3 meters away from the interference-receiving antenna, which was mounted on the top of a variable-height antenna tower.
- c. The antenna is a broadband antenna, and its height is varied from one meter to four meters above the ground to determine the maximum value of the field strength. Both horizontal and vertical polarizations of the antenna are set to make the measurement.
- d. For each suspected emission, the EUT was arranged to its worst case and then the antenna was tuned to heights from 1 meter to 4 meters and the rotatable table was turned from 0 degrees to 360 degrees to find the maximum reading.
- e. The test-receiver system was set to Peak Detect Function and Specified Bandwidth with Maximum Hold Mode.
- f. If the emission level of the EUT in peak mode was lower than the limit specified, then testing could be stopped and the peak values of the EUT would be reported. Otherwise the emissions would be re-tested one by one using peak, quasi-peak or average method as specified and then reported in a data sheet.

NOTE:

1. The resolution bandwidth and video bandwidth of test receiver/spectrum analyzer is 120kHz for Quasi-peak detection at frequency below 1GHz.
2. The resolution bandwidth of test receiver/spectrum analyzer is 1 MHz and video bandwidth is 3MHz for Peak detection at frequency above 1GHz.
3. All modes of operation were investigated and the worst-case emissions are reported.

4.1.4 DEVIATION FROM TEST STANDARD

No deviation.

4.1.5 TEST SETUP

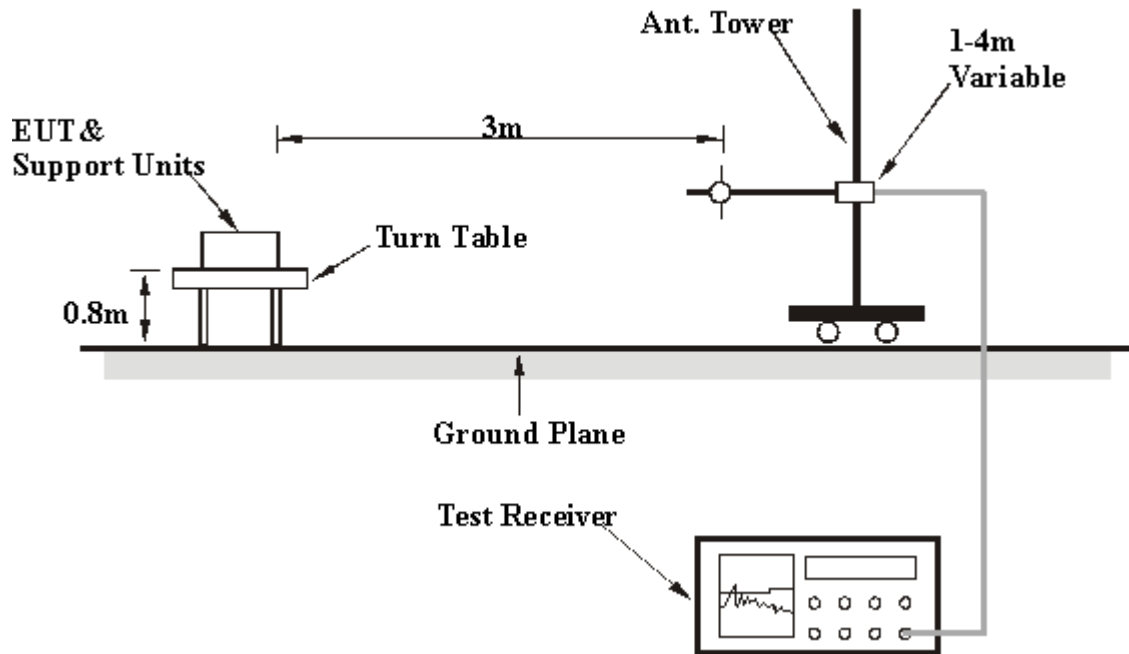

For the actual test configuration, please refer to the attached file (Test Setup Photo).

4.1.6 EUT OPERATING CONDITIONS

Mode A:

- a. Turn on the power of all equipment.
- b. Surface ran a test program (provided by manufacture) to enable EUT under transmitting condition at specific channel continuously.
- c. Set the EUT under transmitting and charging condition.

Mode B:

Set the EUT under transmission/receiving condition continuously at specific channel frequency.



A D T

4.1.7 TEST RESULTS

ABOVE 1GHz DATA

CHANNEL	TX Channel 0	DETECTOR FUNCTION	Peak (PK)
FREQUENCY RANGE	1GHz ~ 25GHz		Average (AV)
MODE	A	SERIAL NO.	DVT000137C32754

ANTENNA POLARITY & TEST DISTANCE: HORIZONTAL AT 3 M								
NO.	FREQ. (MHz)	EMISSION LEVEL (dBuV/m)	LIMIT (dBuV/m)	MARGIN (dB)	ANTENNA HEIGHT (m)	TABLE ANGLE (Degree)	RAW VALUE (dBuV)	CORRECTION FACTOR (dB/m)
1	2390.00	40.4 PK	74.0	-33.6	1.17 H	30	44.18	-3.75
2	2390.00	26.6 AV	54.0	-27.4	1.17 H	30	30.35	-3.75
3	#2400.00	42.0 PK	59.2	-17.2	1.17 H	30	45.65	-3.70
4	#2400.00	32.1 AV	58.6	-26.6	1.17 H	30	35.78	-3.70
5	*2402.00	79.2 PK			1.17 H	30	82.84	-3.69
6	*2402.00	78.6 AV			1.17 H	30	82.33	-3.69
7	4804.00	42.4 PK	74.0	-31.6	1.00 H	200	38.69	3.70
8	4804.00	33.0 AV	54.0	-21.1	1.00 H	200	29.25	3.70

ANTENNA POLARITY & TEST DISTANCE: VERTICAL AT 3 M								
NO.	FREQ. (MHz)	EMISSION LEVEL (dBuV/m)	LIMIT (dBuV/m)	MARGIN (dB)	ANTENNA HEIGHT (m)	TABLE ANGLE (Degree)	RAW VALUE (dBuV)	CORRECTION FACTOR (dB/m)
1	2390.00	41.8 PK	74.0	-32.2	1.00 V	261	45.53	-3.75
2	2390.00	27.3 AV	54.0	-26.7	1.00 V	261	31.07	-3.75
3	#2400.00	45.3 PK	61.3	-16.0	1.00 V	261	48.97	-3.70
4	#2400.00	34.8 AV	60.6	-25.8	1.00 V	261	38.52	-3.70
5	*2402.00	81.3 PK			1.00 V	261	84.94	-3.69
6	*2402.00	80.6 AV			1.00 V	261	84.33	-3.69
7	4804.00	46.2 PK	74.0	-27.8	1.00 V	297	42.49	3.70
8	4804.00	40.1 AV	54.0	-13.9	1.00 V	297	36.36	3.70

REMARKS:

1. Emission Level(dBuV/m) = Raw Value(dBuV) + Correction Factor(dB/m)
2. Correction Factor(dB/m) = Antenna Factor(dB/m) + Cable Factor(dB) – Pre-Amplifier Factor(dB)
3. The other emission levels were very low against the limit.
4. Margin value = Emission Level – Limit value
5. " * ": Fundamental frequency.
6. " # ": The radiated frequency is out of the restricted band.



A D T

CHANNEL	TX Channel 39	DETECTOR FUNCTION	Peak (PK)
FREQUENCY RANGE	1GHz ~ 25GHz		Average (AV)
MODE	A	SERIAL NO.	DVT000137C32754

ANTENNA POLARITY & TEST DISTANCE: HORIZONTAL AT 3 M

NO.	FREQ. (MHz)	EMISSION LEVEL (dBuV/m)	LIMIT (dBuV/m)	MARGIN (dB)	ANTENNA HEIGHT (m)	TABLE ANGLE (Degree)	RAW VALUE (dBuV)	CORRECTION FACTOR (dB/m)
1	*2441.00	79.8 PK			1.10 H	35	83.30	-3.51
2	*2441.00	79.6 AV			1.10 H	35	83.13	-3.51
3	4882.00	42.8 PK	74.0	-31.2	1.00 H	168	39.05	3.76
4	4882.00	30.4 AV	54.0	-23.6	1.00 H	168	26.60	3.76

ANTENNA POLARITY & TEST DISTANCE: VERTICAL AT 3 M

NO.	FREQ. (MHz)	EMISSION LEVEL (dBuV/m)	LIMIT (dBuV/m)	MARGIN (dB)	ANTENNA HEIGHT (m)	TABLE ANGLE (Degree)	RAW VALUE (dBuV)	CORRECTION FACTOR (dB/m)
1	*2441.00	81.6 PK			1.00 V	262	85.06	-3.51
2	*2441.00	81.2 AV			1.00 V	262	84.74	-3.51
3	4882.00	44.8 PK	74.0	-29.2	1.00 V	298	41.07	3.76
4	4882.00	38.0 AV	54.0	-16.0	1.00 V	298	34.24	3.76

REMARKS:

1. Emission Level(dBuV/m) = Raw Value(dBuV) + Correction Factor(dB/m)
2. Correction Factor(dB/m) = Antenna Factor(dB/m) + Cable Factor(dB) – Pre-Amplifier Factor(dB)
3. The other emission levels were very low against the limit.
4. Margin value = Emission Level – Limit value
5. “ * “: Fundamental frequency.



A D T

CHANNEL	TX Channel 78	DETECTOR FUNCTION	Peak (PK)
FREQUENCY RANGE	1GHz ~ 25GHz		Average (AV)
MODE	A	SERIAL NO.	DVT000137C32754

ANTENNA POLARITY & TEST DISTANCE: HORIZONTAL AT 3 M								
NO.	FREQ. (MHz)	EMISSION LEVEL (dBuV/m)	LIMIT (dBuV/m)	MARGIN (dB)	ANTENNA HEIGHT (m)	TABLE ANGLE (Degree)	RAW VALUE (dBuV)	CORRECTION FACTOR (dB/m)
1	*2480.00	82.3 PK			1.00 H	79	85.65	-3.33
2	*2480.00	82.0 AV			1.00 H	79	85.32	-3.33
3	2483.50	41.8 PK	74.0	-32.2	1.00 H	79	45.11	-3.32
4	2483.50	31.0 AV	54.0	-23.0	1.00 H	79	34.33	-3.32
5	4960.00	41.9 PK	74.0	-32.1	1.00 H	198	38.17	3.70
6	4960.00	30.4 AV	54.0	-23.6	1.00 H	198	26.74	3.70
ANTENNA POLARITY & TEST DISTANCE: VERTICAL AT 3 M								
NO.	FREQ. (MHz)	EMISSION LEVEL (dBuV/m)	LIMIT (dBuV/m)	MARGIN (dB)	ANTENNA HEIGHT (m)	TABLE ANGLE (Degree)	RAW VALUE (dBuV)	CORRECTION FACTOR (dB/m)
1	*2480.00	83.7 PK			1.00 V	260	87.01	-3.33
2	*2480.00	83.4 AV			1.00 V	260	86.68	-3.33
3	2483.50	43.7 PK	74.0	-30.3	1.00 V	260	47.01	-3.32
4	2483.50	33.1 AV	54.0	-20.9	1.00 V	260	36.44	-3.32
5	4960.00	44.5 PK	74.0	-29.5	1.00 V	295	40.81	3.70
6	4960.00	35.9 AV	54.0	-18.1	1.00 V	295	32.16	3.70

REMARKS:

1. Emission Level(dBuV/m) = Raw Value(dBuV) + Correction Factor(dB/m)
2. Correction Factor(dB/m) = Antenna Factor(dB/m) + Cable Factor(dB) – Pre-Amplifier Factor(dB)
3. The other emission levels were very low against the limit.
4. Margin value = Emission Level – Limit value
5. “ * “: Fundamental frequency.



A D T

CHANNEL	TX Channel 0	DETECTOR FUNCTION	Peak (PK)
FREQUENCY RANGE	1GHz ~ 25GHz		Average (AV)
MODE	B	SERIAL NO.	DVT000137C32754

ANTENNA POLARITY & TEST DISTANCE: HORIZONTAL AT 3 M								
NO.	FREQ. (MHz)	EMISSION LEVEL (dBuV/m)	LIMIT (dBuV/m)	MARGIN (dB)	ANTENNA HEIGHT (m)	TABLE ANGLE (Degree)	RAW VALUE (dBuV)	CORRECTION FACTOR (dB/m)
1	2390.00	40.2 PK	74.0	-33.8	1.15 H	57	43.95	-3.75
2	2390.00	26.4 AV	54.0	-27.6	1.15 H	57	30.13	-3.75
3	#2400.00	40.5 PK	58.9	-18.3	1.15 H	57	44.23	-3.70
4	#2400.00	30.5 AV	58.7	-28.2	1.15 H	57	34.17	-3.70
5	*2402.00	78.9 PK			1.15 H	57	82.56	-3.69
6	*2402.00	78.7 AV			1.15 H	57	82.37	-3.69
7	4804.00	42.3 PK	74.0	-31.7	1.02 H	193	38.56	3.70
8	4804.00	32.9 AV	54.0	-21.1	1.02 H	193	29.22	3.70

ANTENNA POLARITY & TEST DISTANCE: VERTICAL AT 3 M								
NO.	FREQ. (MHz)	EMISSION LEVEL (dBuV/m)	LIMIT (dBuV/m)	MARGIN (dB)	ANTENNA HEIGHT (m)	TABLE ANGLE (Degree)	RAW VALUE (dBuV)	CORRECTION FACTOR (dB/m)
1	2390.00	42.0 PK	74.0	-32.0	1.00 V	200	45.73	-3.75
2	2390.00	28.0 AV	54.0	-26.0	1.00 V	200	31.74	-3.75
3	#2400.00	42.7 PK	61.2	-18.5	1.00 V	200	46.37	-3.70
4	#2400.00	31.4 AV	61.0	-29.6	1.00 V	200	35.06	-3.70
5	*2402.00	81.2 PK			1.00 V	200	84.85	-3.69
6	*2402.00	81.0 AV			1.00 V	200	84.67	-3.69
7	4804.00	45.7 PK	74.0	-28.3	1.02 V	288	41.98	3.70
8	4804.00	39.2 AV	54.0	-14.8	1.02 V	288	35.46	3.70

REMARKS:

1. Emission Level(dBuV/m) = Raw Value(dBuV) + Correction Factor(dB/m)
2. Correction Factor(dB/m) = Antenna Factor(dB/m) + Cable Factor(dB) – Pre-Amplifier Factor(dB)
3. The other emission levels were very low against the limit.
4. Margin value = Emission Level – Limit value
5. " * ": Fundamental frequency.
6. " # ": The radiated frequency is out of the restricted band.



A D T

CHANNEL	TX Channel 39	DETECTOR FUNCTION	Peak (PK)
FREQUENCY RANGE	1GHz ~ 25GHz		Average (AV)
MODE	B	SERIAL NO.	DVT000137C32754

ANTENNA POLARITY & TEST DISTANCE: HORIZONTAL AT 3 M								
NO.	FREQ. (MHz)	EMISSION LEVEL (dBuV/m)	LIMIT (dBuV/m)	MARGIN (dB)	ANTENNA HEIGHT (m)	TABLE ANGLE (Degree)	RAW VALUE (dBuV)	CORRECTION FACTOR (dB/m)
1	*2441.00	79.8 PK			1.13 H	62	83.31	-3.51
2	*2441.00	79.6 AV			1.13 H	62	83.08	-3.51
3	4882.00	42.7 PK	74.0	-31.3	1.00 H	196	38.97	3.76
4	4882.00	30.3 AV	54.0	-23.7	1.00 H	196	26.53	3.76
ANTENNA POLARITY & TEST DISTANCE: VERTICAL AT 3 M								
NO.	FREQ. (MHz)	EMISSION LEVEL (dBuV/m)	LIMIT (dBuV/m)	MARGIN (dB)	ANTENNA HEIGHT (m)	TABLE ANGLE (Degree)	RAW VALUE (dBuV)	CORRECTION FACTOR (dB/m)
1	*2441.00	81.5 PK			1.00 V	203	84.96	-3.51
2	*2441.00	81.3 AV			1.00 V	203	84.78	-3.51
3	4882.00	44.9 PK	74.0	-29.1	1.00 V	276	41.18	3.76
4	4882.00	38.1 AV	54.0	-15.9	1.00 V	276	34.33	3.76

REMARKS:

1. Emission Level(dBuV/m) = Raw Value(dBuV) + Correction Factor(dB/m)
2. Correction Factor(dB/m) = Antenna Factor(dB/m) + Cable Factor(dB) – Pre-Amplifier Factor(dB)
3. The other emission levels were very low against the limit.
4. Margin value = Emission Level – Limit value
5. “ * “: Fundamental frequency.



A D T

CHANNEL	TX Channel 78	DETECTOR FUNCTION	Peak (PK)
FREQUENCY RANGE	1GHz ~ 25GHz		Average (AV)
MODE	B	SERIAL NO.	DVT000137C32754

ANTENNA POLARITY & TEST DISTANCE: HORIZONTAL AT 3 M								
NO.	FREQ. (MHz)	EMISSION LEVEL (dBuV/m)	LIMIT (dBuV/m)	MARGIN (dB)	ANTENNA HEIGHT (m)	TABLE ANGLE (Degree)	RAW VALUE (dBuV)	CORRECTION FACTOR (dB/m)
1	*2480.00	82.2 PK			1.14 H	56	85.57	-3.33
2	*2480.00	82.0 AV			1.14 H	56	85.29	-3.33
3	2483.50	41.7 PK	74.0	-32.3	1.14 H	56	45.02	-3.32
4	2483.50	31.1 AV	54.0	-22.9	1.14 H	56	34.38	-3.32
5	4960.00	41.9 PK	74.0	-32.1	1.00 H	187	38.21	3.70
6	4960.00	30.4 AV	54.0	-23.6	1.00 H	187	26.71	3.70
ANTENNA POLARITY & TEST DISTANCE: VERTICAL AT 3 M								
NO.	FREQ. (MHz)	EMISSION LEVEL (dBuV/m)	LIMIT (dBuV/m)	MARGIN (dB)	ANTENNA HEIGHT (m)	TABLE ANGLE (Degree)	RAW VALUE (dBuV)	CORRECTION FACTOR (dB/m)
1	*2480.00	83.6 PK			1.00 V	199	86.95	-3.33
2	*2480.00	83.2 AV			1.00 V	199	86.53	-3.33
3	2483.50	43.7 PK	74.0	-30.3	1.00 V	199	47.00	-3.32
4	2483.50	33.1 AV	54.0	-20.9	1.00 V	199	36.38	-3.32
5	4960.00	44.5 PK	74.0	-29.5	1.01 V	291	40.80	3.70
6	4960.00	35.9 AV	54.0	-18.1	1.01 V	291	32.24	3.70

REMARKS:

1. Emission Level(dBuV/m) = Raw Value(dBuV) + Correction Factor(dB/m)
2. Correction Factor(dB/m) = Antenna Factor(dB/m) + Cable Factor(dB) – Pre-Amplifier Factor(dB)
3. The other emission levels were very low against the limit.
4. Margin value = Emission Level – Limit value
5. “ * “: Fundamental frequency.



A D T

ABOVE 1GHz DATA (For Harmonics)

CHANNEL	TX Channel 0	DETECTOR FUNCTION	Peak (PK)
FREQUENCY RANGE	1GHz ~ 25GHz		Average (AV)
MODE	A	SERIAL NO.	DVT000025C32754

ANTENNA POLARITY & TEST DISTANCE: HORIZONTAL AT 3 M								
NO.	FREQ. (MHz)	EMISSION LEVEL (dBuV/m)	LIMIT (dBuV/m)	MARGIN (dB)	ANTENNA HEIGHT (m)	TABLE ANGLE (Degree)	RAW VALUE (dBuV)	CORRECTION FACTOR (dB/m)
1	4804.00	45.4 PK	74.0	-28.6	1.30 H	164	41.66	3.70
2	4804.00	38.4 AV	54.0	-15.6	1.30 H	164	34.68	3.70
ANTENNA POLARITY & TEST DISTANCE: VERTICAL AT 3 M								
NO.	FREQ. (MHz)	EMISSION LEVEL (dBuV/m)	LIMIT (dBuV/m)	MARGIN (dB)	ANTENNA HEIGHT (m)	TABLE ANGLE (Degree)	RAW VALUE (dBuV)	CORRECTION FACTOR (dB/m)
1	4804.00	47.8 PK	74.0	-26.2	1.00 V	211	44.14	3.70
2	4804.00	43.0 AV	54.0	-11.0	1.00 V	211	39.31	3.70

REMARKS:

1. Emission Level(dBuV/m) = Raw Value(dBuV) + Correction Factor(dB/m)
2. Correction Factor(dB/m) = Antenna Factor(dB/m) + Cable Factor(dB) – Pre-Amplifier Factor(dB)
3. The other emission levels were very low against the limit.
4. Margin value = Emission Level – Limit value



A D T

CHANNEL	TX Channel 39	DETECTOR FUNCTION	Peak (PK)
FREQUENCY RANGE	1GHz ~ 25GHz		Average (AV)
MODE	A	SERIAL NO.	DVT000025C32754

ANTENNA POLARITY & TEST DISTANCE: HORIZONTAL AT 3 M								
NO.	FREQ. (MHz)	EMISSION LEVEL (dBuV/m)	LIMIT (dBuV/m)	MARGIN (dB)	ANTENNA HEIGHT (m)	TABLE ANGLE (Degree)	RAW VALUE (dBuV)	CORRECTION FACTOR (dB/m)
1	4882.00	45.7 PK	74.0	-28.3	1.24 H	159	41.92	3.76
2	4882.00	38.6 AV	54.0	-15.4	1.24 H	159	34.85	3.76
ANTENNA POLARITY & TEST DISTANCE: VERTICAL AT 3 M								
NO.	FREQ. (MHz)	EMISSION LEVEL (dBuV/m)	LIMIT (dBuV/m)	MARGIN (dB)	ANTENNA HEIGHT (m)	TABLE ANGLE (Degree)	RAW VALUE (dBuV)	CORRECTION FACTOR (dB/m)
1	4882.00	48.8 PK	74.0	-25.2	1.07 V	168	45.05	3.76
2	4882.00	44.8 AV	54.0	-9.2	1.07 V	168	41.02	3.76

REMARKS:

1. Emission Level(dBuV/m) = Raw Value(dBuV) + Correction Factor(dB/m)
2. Correction Factor(dB/m) = Antenna Factor(dB/m) + Cable Factor(dB) – Pre-Amplifier Factor(dB)
3. The other emission levels were very low against the limit.
4. Margin value = Emission Level – Limit value



A D T

CHANNEL	TX Channel 78	DETECTOR FUNCTION	Peak (PK)
FREQUENCY RANGE	1GHz ~ 25GHz		Average (AV)
MODE	A	SERIAL NO.	DVT000025C32754

ANTENNA POLARITY & TEST DISTANCE: HORIZONTAL AT 3 M								
NO.	FREQ. (MHz)	EMISSION LEVEL (dBuV/m)	LIMIT (dBuV/m)	MARGIN (dB)	ANTENNA HEIGHT (m)	TABLE ANGLE (Degree)	RAW VALUE (dBuV)	CORRECTION FACTOR (dB/m)
1	4960.00	45.7 PK	74.0	-28.3	1.07 H	162	42.02	3.70
2	4960.00	37.9 AV	54.0	-16.1	1.07 H	162	34.24	3.70
ANTENNA POLARITY & TEST DISTANCE: VERTICAL AT 3 M								
NO.	FREQ. (MHz)	EMISSION LEVEL (dBuV/m)	LIMIT (dBuV/m)	MARGIN (dB)	ANTENNA HEIGHT (m)	TABLE ANGLE (Degree)	RAW VALUE (dBuV)	CORRECTION FACTOR (dB/m)
1	4960.00	49.8 PK	74.0	-24.2	1.04 V	165	46.09	3.70
2	4960.00	46.3 AV	54.0	-7.7	1.04 V	165	42.60	3.70

REMARKS:

1. Emission Level(dBuV/m) = Raw Value(dBuV) + Correction Factor(dB/m)
2. Correction Factor(dB/m) = Antenna Factor(dB/m) + Cable Factor(dB) – Pre-Amplifier Factor(dB)
3. The other emission levels were very low against the limit.
4. Margin value = Emission Level – Limit value



A D T

ABOVE 1GHz DATA (For Harmonics)

CHANNEL	TX Channel 0	DETECTOR FUNCTION	Peak (PK)
FREQUENCY RANGE	1GHz ~ 25GHz		Average (AV)
MODE	A	SERIAL NO.	DVT000143C32754

ANTENNA POLARITY & TEST DISTANCE: HORIZONTAL AT 3 M								
NO.	FREQ. (MHz)	EMISSION LEVEL (dBuV/m)	LIMIT (dBuV/m)	MARGIN (dB)	ANTENNA HEIGHT (m)	TABLE ANGLE (Degree)	RAW VALUE (dBuV)	CORRECTION FACTOR (dB/m)
1	4804.00	45.5 PK	74.0	-28.6	1.22 H	163	41.75	3.70
2	4804.00	38.8 AV	54.0	-15.2	1.22 H	163	35.11	3.70
ANTENNA POLARITY & TEST DISTANCE: VERTICAL AT 3 M								
NO.	FREQ. (MHz)	EMISSION LEVEL (dBuV/m)	LIMIT (dBuV/m)	MARGIN (dB)	ANTENNA HEIGHT (m)	TABLE ANGLE (Degree)	RAW VALUE (dBuV)	CORRECTION FACTOR (dB/m)
1	4804.00	47.8 PK	74.0	-26.2	1.00 V	199	44.13	3.70
2	4804.00	42.9 AV	54.0	-11.2	1.00 V	199	39.15	3.70

REMARKS:

1. Emission Level(dBuV/m) = Raw Value(dBuV) + Correction Factor(dB/m)
2. Correction Factor(dB/m) = Antenna Factor(dB/m) + Cable Factor(dB) – Pre-Amplifier Factor(dB)
3. The other emission levels were very low against the limit.
4. Margin value = Emission Level – Limit value



A D T

CHANNEL	TX Channel 39	DETECTOR FUNCTION	Peak (PK)
FREQUENCY RANGE	1GHz ~ 25GHz		Average (AV)
MODE	A	SERIAL NO.	DVT000143C32754

ANTENNA POLARITY & TEST DISTANCE: HORIZONTAL AT 3 M								
NO.	FREQ. (MHz)	EMISSION LEVEL (dBuV/m)	LIMIT (dBuV/m)	MARGIN (dB)	ANTENNA HEIGHT (m)	TABLE ANGLE (Degree)	RAW VALUE (dBuV)	CORRECTION FACTOR (dB/m)
1	4882.00	45.6 PK	74.0	-28.4	1.18 H	157	41.82	3.76
2	4882.00	38.8 AV	54.0	-15.2	1.18 H	157	35.03	3.76
ANTENNA POLARITY & TEST DISTANCE: VERTICAL AT 3 M								
NO.	FREQ. (MHz)	EMISSION LEVEL (dBuV/m)	LIMIT (dBuV/m)	MARGIN (dB)	ANTENNA HEIGHT (m)	TABLE ANGLE (Degree)	RAW VALUE (dBuV)	CORRECTION FACTOR (dB/m)
1	4882.00	48.6 PK	74.0	-25.4	1.04 V	161	44.84	3.76
2	4882.00	43.7 AV	54.0	-10.3	1.04 V	161	39.93	3.76

REMARKS:

1. Emission Level(dBuV/m) = Raw Value(dBuV) + Correction Factor(dB/m)
2. Correction Factor(dB/m) = Antenna Factor(dB/m) + Cable Factor(dB) – Pre-Amplifier Factor(dB)
3. The other emission levels were very low against the limit.
4. Margin value = Emission Level – Limit value



A D T

CHANNEL	TX Channel 78	DETECTOR FUNCTION	Peak (PK)
FREQUENCY RANGE	1GHz ~ 25GHz		Average (AV)
MODE	A	SERIAL NO.	DVT000143C32754

ANTENNA POLARITY & TEST DISTANCE: HORIZONTAL AT 3 M								
NO.	FREQ. (MHz)	EMISSION LEVEL (dBuV/m)	LIMIT (dBuV/m)	MARGIN (dB)	ANTENNA HEIGHT (m)	TABLE ANGLE (Degree)	RAW VALUE (dBuV)	CORRECTION FACTOR (dB/m)
1	4960.00	45.8 PK	74.0	-28.2	1.04 H	166	42.08	3.70
2	4960.00	38.9 AV	54.0	-15.1	1.04 H	166	35.21	3.70
ANTENNA POLARITY & TEST DISTANCE: VERTICAL AT 3 M								
NO.	FREQ. (MHz)	EMISSION LEVEL (dBuV/m)	LIMIT (dBuV/m)	MARGIN (dB)	ANTENNA HEIGHT (m)	TABLE ANGLE (Degree)	RAW VALUE (dBuV)	CORRECTION FACTOR (dB/m)
1	4960.00	49.6 PK	74.0	-24.4	1.02 V	152	45.88	3.70
2	4960.00	45.5 AV	54.0	-8.5	1.02 V	152	41.84	3.70

REMARKS:

1. Emission Level(dBuV/m) = Raw Value(dBuV) + Correction Factor(dB/m)
2. Correction Factor(dB/m) = Antenna Factor(dB/m) + Cable Factor(dB) – Pre-Amplifier Factor(dB)
3. The other emission levels were very low against the limit.
4. Margin value = Emission Level – Limit value



A D T

ABOVE 1GHz DATA (For Harmonics)

CHANNEL	TX Channel 0	DETECTOR FUNCTION	Peak (PK)
FREQUENCY RANGE	1GHz ~ 25GHz		Average (AV)
MODE	B	SERIAL NO.	DVT000025C32754

ANTENNA POLARITY & TEST DISTANCE: HORIZONTAL AT 3 M								
NO.	FREQ. (MHz)	EMISSION LEVEL (dBuV/m)	LIMIT (dBuV/m)	MARGIN (dB)	ANTENNA HEIGHT (m)	TABLE ANGLE (Degree)	RAW VALUE (dBuV)	CORRECTION FACTOR (dB/m)
1	4804.00	45.4 PK	74.0	-28.6	1.26 H	158	41.73	3.70
2	4804.00	38.2 AV	54.0	-15.8	1.26 H	158	34.51	3.70
ANTENNA POLARITY & TEST DISTANCE: VERTICAL AT 3 M								
NO.	FREQ. (MHz)	EMISSION LEVEL (dBuV/m)	LIMIT (dBuV/m)	MARGIN (dB)	ANTENNA HEIGHT (m)	TABLE ANGLE (Degree)	RAW VALUE (dBuV)	CORRECTION FACTOR (dB/m)
1	4804.00	47.8 PK	74.0	-26.2	1.02 V	208	44.08	3.70
2	4804.00	42.9 AV	54.0	-11.1	1.02 V	208	39.20	3.70

REMARKS:

1. Emission Level(dBuV/m) = Raw Value(dBuV) + Correction Factor(dB/m)
2. Correction Factor(dB/m) = Antenna Factor(dB/m) + Cable Factor(dB) – Pre-Amplifier Factor(dB)
3. The other emission levels were very low against the limit.
4. Margin value = Emission Level – Limit value



A D T

CHANNEL	TX Channel 39	DETECTOR FUNCTION	Peak (PK)
FREQUENCY RANGE	1GHz ~ 25GHz		Average (AV)
MODE	B	SERIAL NO.	DVT000025C32754

ANTENNA POLARITY & TEST DISTANCE: HORIZONTAL AT 3 M								
NO.	FREQ. (MHz)	EMISSION LEVEL (dBuV/m)	LIMIT (dBuV/m)	MARGIN (dB)	ANTENNA HEIGHT (m)	TABLE ANGLE (Degree)	RAW VALUE (dBuV)	CORRECTION FACTOR (dB/m)
1	4882.00	45.5 PK	74.0	-28.5	1.22 H	163	41.78	3.76
2	4882.00	38.7 AV	54.0	-15.3	1.22 H	163	34.92	3.76
ANTENNA POLARITY & TEST DISTANCE: VERTICAL AT 3 M								
NO.	FREQ. (MHz)	EMISSION LEVEL (dBuV/m)	LIMIT (dBuV/m)	MARGIN (dB)	ANTENNA HEIGHT (m)	TABLE ANGLE (Degree)	RAW VALUE (dBuV)	CORRECTION FACTOR (dB/m)
1	4882.00	48.7 PK	74.0	-25.4	1.06 V	175	44.89	3.76
2	4882.00	44.8 AV	54.0	-9.2	1.06 V	175	41.00	3.76

REMARKS:

1. Emission Level(dBuV/m) = Raw Value(dBuV) + Correction Factor(dB/m)
2. Correction Factor(dB/m) = Antenna Factor(dB/m) + Cable Factor(dB) – Pre-Amplifier Factor(dB)
3. The other emission levels were very low against the limit.
4. Margin value = Emission Level – Limit value



A D T

CHANNEL	TX Channel 78	DETECTOR FUNCTION	Peak (PK)
FREQUENCY RANGE	1GHz ~ 25GHz		Average (AV)
MODE	B	SERIAL NO.	DVT000025C32754

ANTENNA POLARITY & TEST DISTANCE: HORIZONTAL AT 3 M								
NO.	FREQ. (MHz)	EMISSION LEVEL (dBuV/m)	LIMIT (dBuV/m)	MARGIN (dB)	ANTENNA HEIGHT (m)	TABLE ANGLE (Degree)	RAW VALUE (dBuV)	CORRECTION FACTOR (dB/m)
1	4960.00	45.8 PK	74.0	-28.2	1.06 H	168	42.13	3.70
2	4960.00	38.8 AV	54.0	-15.2	1.06 H	168	35.11	3.70
ANTENNA POLARITY & TEST DISTANCE: VERTICAL AT 3 M								
NO.	FREQ. (MHz)	EMISSION LEVEL (dBuV/m)	LIMIT (dBuV/m)	MARGIN (dB)	ANTENNA HEIGHT (m)	TABLE ANGLE (Degree)	RAW VALUE (dBuV)	CORRECTION FACTOR (dB/m)
1	4960.00	49.9 PK	74.0	-24.1	1.00 V	158	46.21	3.70
2	4960.00	46.4 AV	54.0	-7.6	1.00 V	158	42.73	3.70

REMARKS:

1. Emission Level(dBuV/m) = Raw Value(dBuV) + Correction Factor(dB/m)
2. Correction Factor(dB/m) = Antenna Factor(dB/m) + Cable Factor(dB) – Pre-Amplifier Factor(dB)
3. The other emission levels were very low against the limit.
4. Margin value = Emission Level – Limit value



A D T

ABOVE 1GHz DATA (For Harmonics)

CHANNEL	TX Channel 0	DETECTOR FUNCTION	Peak (PK)
FREQUENCY RANGE	1GHz ~ 25GHz		Average (AV)
MODE	B	SERIAL NO.	DVT000143C32754

ANTENNA POLARITY & TEST DISTANCE: HORIZONTAL AT 3 M								
NO.	FREQ. (MHz)	EMISSION LEVEL (dBuV/m)	LIMIT (dBuV/m)	MARGIN (dB)	ANTENNA HEIGHT (m)	TABLE ANGLE (Degree)	RAW VALUE (dBuV)	CORRECTION FACTOR (dB/m)
1	4804.00	45.5 PK	74.0	-28.5	1.27 H	151	41.83	3.70
2	4804.00	39.0 AV	54.0	-15.0	1.27 H	151	35.26	3.70
ANTENNA POLARITY & TEST DISTANCE: VERTICAL AT 3 M								
NO.	FREQ. (MHz)	EMISSION LEVEL (dBuV/m)	LIMIT (dBuV/m)	MARGIN (dB)	ANTENNA HEIGHT (m)	TABLE ANGLE (Degree)	RAW VALUE (dBuV)	CORRECTION FACTOR (dB/m)
1	4804.00	48.0 PK	74.0	-26.1	1.03 V	207	44.25	3.70
2	4804.00	43.7 AV	54.0	-10.3	1.03 V	207	40.03	3.70

REMARKS:

1. Emission Level(dBuV/m) = Raw Value(dBuV) + Correction Factor(dB/m)
2. Correction Factor(dB/m) = Antenna Factor(dB/m) + Cable Factor(dB) – Pre-Amplifier Factor(dB)
3. The other emission levels were very low against the limit.
4. Margin value = Emission Level – Limit value



A D T

CHANNEL	TX Channel 39	DETECTOR FUNCTION	Peak (PK)
FREQUENCY RANGE	1GHz ~ 25GHz		Average (AV)
MODE	B	SERIAL NO.	DVT000143C32754

ANTENNA POLARITY & TEST DISTANCE: HORIZONTAL AT 3 M								
NO.	FREQ. (MHz)	EMISSION LEVEL (dBuV/m)	LIMIT (dBuV/m)	MARGIN (dB)	ANTENNA HEIGHT (m)	TABLE ANGLE (Degree)	RAW VALUE (dBuV)	CORRECTION FACTOR (dB/m)
1	4882.00	45.4 PK	74.0	-28.6	1.14 H	173	41.64	3.76
2	4882.00	38.9 AV	54.0	-15.1	1.14 H	173	35.12	3.76
ANTENNA POLARITY & TEST DISTANCE: VERTICAL AT 3 M								
NO.	FREQ. (MHz)	EMISSION LEVEL (dBuV/m)	LIMIT (dBuV/m)	MARGIN (dB)	ANTENNA HEIGHT (m)	TABLE ANGLE (Degree)	RAW VALUE (dBuV)	CORRECTION FACTOR (dB/m)
1	4882.00	48.8 PK	74.0	-25.2	1.01 V	164	45.03	3.76
2	4882.00	43.8 AV	54.0	-10.2	1.01 V	164	40.08	3.76

REMARKS:

1. Emission Level(dBuV/m) = Raw Value(dBuV) + Correction Factor(dB/m)
2. Correction Factor(dB/m) = Antenna Factor(dB/m) + Cable Factor(dB) – Pre-Amplifier Factor(dB)
3. The other emission levels were very low against the limit.
4. Margin value = Emission Level – Limit value



A D T

CHANNEL	TX Channel 78	DETECTOR FUNCTION	Peak (PK)
FREQUENCY RANGE	1GHz ~ 25GHz		Average (AV)
MODE	B	SERIAL NO.	DVT000143C32754

ANTENNA POLARITY & TEST DISTANCE: HORIZONTAL AT 3 M								
NO.	FREQ. (MHz)	EMISSION LEVEL (dBuV/m)	LIMIT (dBuV/m)	MARGIN (dB)	ANTENNA HEIGHT (m)	TABLE ANGLE (Degree)	RAW VALUE (dBuV)	CORRECTION FACTOR (dB/m)
1	4960.00	45.9 PK	74.0	-28.1	1.05 H	159	42.24	3.70
2	4960.00	39.1 AV	54.0	-14.9	1.05 H	159	35.36	3.70
ANTENNA POLARITY & TEST DISTANCE: VERTICAL AT 3 M								
NO.	FREQ. (MHz)	EMISSION LEVEL (dBuV/m)	LIMIT (dBuV/m)	MARGIN (dB)	ANTENNA HEIGHT (m)	TABLE ANGLE (Degree)	RAW VALUE (dBuV)	CORRECTION FACTOR (dB/m)
1	4960.00	49.0 PK	74.0	-25.0	1.05 V	171	45.34	3.70
2	4960.00	44.5 AV	54.0	-9.5	1.05 V	171	40.76	3.70

REMARKS:

1. Emission Level(dBuV/m) = Raw Value(dBuV) + Correction Factor(dB/m)
2. Correction Factor(dB/m) = Antenna Factor(dB/m) + Cable Factor(dB) – Pre-Amplifier Factor(dB)
3. The other emission levels were very low against the limit.
4. Margin value = Emission Level – Limit value



A D T

BELOW 1GHz WORST-CASE DATA :

CHANNEL	TX Channel 78	DETECTOR FUNCTION	Quasi-Peak
FREQUENCY RANGE	30MHz ~ 1GHz		
MODE	A	SERIAL NO.	DVT000137C32754

ANTENNA POLARITY & TEST DISTANCE: HORIZONTAL AT 3 M								
NO.	FREQ. (MHz)	EMISSION LEVEL (dBuV/m)	LIMIT (dBuV/m)	MARGIN (dB)	ANTENNA HEIGHT (m)	TABLE ANGLE (Degree)	RAW VALUE (dBuV)	CORRECTION FACTOR (dB/m)
1	93.14	37.4 QP	43.5	-6.2	2.16 H	219	56.32	-18.97
2	179.38	32.3 QP	43.5	-11.2	1.49 H	174	46.54	-14.27
3	264.74	34.8 QP	46.0	-11.2	1.00 H	177	47.59	-12.82
4	611.03	25.1 QP	46.0	-20.9	1.49 H	341	30.26	-5.15
5	800.18	28.9 QP	46.0	-17.1	1.00 H	68	30.85	-1.94
6	921.43	29.4 QP	46.0	-16.7	3.00 H	307	29.40	-0.05
ANTENNA POLARITY & TEST DISTANCE: VERTICAL AT 3 M								
NO.	FREQ. (MHz)	EMISSION LEVEL (dBuV/m)	LIMIT (dBuV/m)	MARGIN (dB)	ANTENNA HEIGHT (m)	TABLE ANGLE (Degree)	RAW VALUE (dBuV)	CORRECTION FACTOR (dB/m)
1	93.05	30.6 QP	43.5	-12.9	1.00 V	121	49.58	-18.98
2	114.39	24.7 QP	43.5	-18.8	1.00 V	21	41.06	-16.38
3	197.81	24.6 QP	43.5	-18.9	1.00 V	75	40.38	-15.82
4	258.92	23.9 QP	46.0	-22.1	1.00 V	235	37.00	-13.14
5	636.25	26.2 QP	46.0	-19.8	1.00 V	207	30.68	-4.51
6	761.38	27.0 QP	46.0	-19.0	1.00 V	147	29.32	-2.32

REMARKS:

1. Emission Level(dBuV/m) = Raw Value(dBuV) + Correction Factor(dB/m)
2. Correction Factor(dB/m) = Antenna Factor(dB/m) + Cable Factor(dB) – Pre-Amplifier Factor(dB)
3. The other emission levels were very low against the limit.
4. Margin value = Emission Level – Limit value



A D T

CHANNEL	TX Channel 78	DETECTOR FUNCTION	Quasi-Peak
FREQUENCY RANGE	30MHz ~ 1GHz		
MODE	A	SERIAL NO.	DVT000025C32754

ANTENNA POLARITY & TEST DISTANCE: HORIZONTAL AT 3 M

NO.	FREQ. (MHz)	EMISSION LEVEL (dBuV/m)	LIMIT (dBuV/m)	MARGIN (dB)	ANTENNA HEIGHT (m)	TABLE ANGLE (Degree)	RAW VALUE (dBuV)	CORRECTION FACTOR (dB/m)
1	92.08	37.3 QP	43.5	-6.2	2.00 H	220	56.44	-19.11
2	179.38	31.7 QP	43.5	-11.8	2.00 H	193	46.00	-14.27
3	262.80	31.3 QP	46.0	-14.7	1.50 H	10	44.17	-12.89
4	585.81	23.4 QP	46.0	-22.6	1.50 H	97	29.00	-5.61
5	709.00	25.3 QP	46.0	-20.7	2.00 H	217	29.00	-3.71
6	849.65	28.0 QP	46.0	-18.0	1.50 H	37	29.33	-1.30

ANTENNA POLARITY & TEST DISTANCE: VERTICAL AT 3 M

NO.	FREQ. (MHz)	EMISSION LEVEL (dBuV/m)	LIMIT (dBuV/m)	MARGIN (dB)	ANTENNA HEIGHT (m)	TABLE ANGLE (Degree)	RAW VALUE (dBuV)	CORRECTION FACTOR (dB/m)
1	92.08	27.9 QP	43.5	-15.6	1.49 V	124	47.05	-19.11
2	182.29	22.5 QP	43.5	-21.0	1.49 V	315	37.40	-14.91
3	263.77	24.0 QP	46.0	-22.0	1.49 V	74	36.84	-12.84
4	622.67	25.9 QP	46.0	-20.1	1.01 V	345	30.65	-4.78
5	776.90	26.8 QP	46.0	-19.2	1.49 V	162	28.88	-2.12
6	897.18	27.6 QP	46.0	-18.4	1.49 V	194	28.21	-0.63

REMARKS:

1. Emission Level(dBuV/m) = Raw Value(dBuV) + Correction Factor(dB/m)
2. Correction Factor(dB/m) = Antenna Factor(dB/m) + Cable Factor(dB) – Pre-Amplifier Factor(dB)
3. The other emission levels were very low against the limit.
4. Margin value = Emission Level – Limit value



A D T

CHANNEL	TX Channel 78	DETECTOR FUNCTION	Quasi-Peak
FREQUENCY RANGE	30MHz ~ 1GHz		
MODE	A	SERIAL NO.	DVT000143C32754

ANTENNA POLARITY & TEST DISTANCE: HORIZONTAL AT 3 M								
NO.	FREQ. (MHz)	EMISSION LEVEL (dBuV/m)	LIMIT (dBuV/m)	MARGIN (dB)	ANTENNA HEIGHT (m)	TABLE ANGLE (Degree)	RAW VALUE (dBuV)	CORRECTION FACTOR (dB/m)
1	93.05	37.4 QP	43.5	-6.1	2.00 H	57	56.36	-18.98
2	183.26	32.4 QP	43.5	-11.1	1.00 H	186	47.41	-15.05
3	256.98	33.8 QP	46.0	-12.2	1.00 H	173	47.04	-13.27
4	556.71	23.2 QP	46.0	-22.8	1.00 H	292	29.73	-6.50
5	742.95	26.0 QP	46.0	-20.1	1.00 H	283	28.76	-2.81
6	854.50	28.2 QP	46.0	-17.8	1.00 H	316	29.36	-1.19
ANTENNA POLARITY & TEST DISTANCE: VERTICAL AT 3 M								
NO.	FREQ. (MHz)	EMISSION LEVEL (dBuV/m)	LIMIT (dBuV/m)	MARGIN (dB)	ANTENNA HEIGHT (m)	TABLE ANGLE (Degree)	RAW VALUE (dBuV)	CORRECTION FACTOR (dB/m)
1	94.02	30.5 QP	43.5	-13.0	1.01 V	124	49.32	-18.85
2	182.29	23.6 QP	43.5	-19.9	2.00 V	297	38.55	-14.91
3	264.74	23.7 QP	46.0	-22.3	1.01 V	218	36.51	-12.82
4	525.67	22.0 QP	46.0	-24.0	1.01 V	238	28.96	-6.95
5	635.28	25.3 QP	46.0	-20.7	1.01 V	17	29.77	-4.50
6	777.87	27.0 QP	46.0	-19.0	1.01 V	195	29.16	-2.13

REMARKS:

1. Emission Level(dBuV/m) = Raw Value(dBuV) + Correction Factor(dB/m)
2. Correction Factor(dB/m) = Antenna Factor(dB/m) + Cable Factor(dB) – Pre-Amplifier Factor(dB)
3. The other emission levels were very low against the limit.
4. Margin value = Emission Level – Limit value



A D T

BELOW 1GHz WORST-CASE DATA :

CHANNEL	TX Channel 78	DETECTOR FUNCTION	Quasi-Peak
FREQUENCY RANGE	30MHz ~ 1GHz		
MODE	B	SERIAL NO.	DVT000137C32754

ANTENNA POLARITY & TEST DISTANCE: HORIZONTAL AT 3 M								
NO.	FREQ. (MHz)	EMISSION LEVEL (dBuV/m)	LIMIT (dBuV/m)	MARGIN (dB)	ANTENNA HEIGHT (m)	TABLE ANGLE (Degree)	RAW VALUE (dBuV)	CORRECTION FACTOR (dB/m)
1	48.43	13.7 QP	40.0	-26.3	1.06 H	54	27.61	-13.87
2	120.21	17.1 QP	43.5	-26.4	1.02 H	266	32.93	-15.86
3	159.98	16.6 QP	43.5	-26.9	1.14 H	295	29.76	-13.13
4	193.93	14.9 QP	43.5	-28.6	1.03 H	229	30.76	-15.87
5	301.60	16.2 QP	46.0	-29.9	1.01 H	211	27.53	-11.38
6	475.23	20.9 QP	46.0	-25.1	1.00 H	325	28.75	-7.85
ANTENNA POLARITY & TEST DISTANCE: VERTICAL AT 3 M								
NO.	FREQ. (MHz)	EMISSION LEVEL (dBuV/m)	LIMIT (dBuV/m)	MARGIN (dB)	ANTENNA HEIGHT (m)	TABLE ANGLE (Degree)	RAW VALUE (dBuV)	CORRECTION FACTOR (dB/m)
1	41.64	18.0 QP	40.0	-22.0	1.04 V	82	32.40	-14.41
2	115.36	15.7 QP	43.5	-27.8	1.02 V	115	31.82	-16.13
3	191.99	25.2 QP	43.5	-18.3	1.13 V	250	41.07	-15.86
4	286.08	18.2 QP	46.0	-27.8	1.05 V	110	30.09	-11.89
5	470.38	21.3 QP	46.0	-24.7	1.21 V	272	29.31	-7.99
6	628.49	25.2 QP	46.0	-20.8	1.06 V	28	29.83	-4.66

REMARKS:

1. Emission Level(dBuV/m) = Raw Value(dBuV) + Correction Factor(dB/m)
2. Correction Factor(dB/m) = Antenna Factor(dB/m) + Cable Factor(dB) – Pre-Amplifier Factor(dB)
3. The other emission levels were very low against the limit.
4. Margin value = Emission Level – Limit value



A D T

CHANNEL	TX Channel 78	DETECTOR FUNCTION	Quasi-Peak
FREQUENCY RANGE	30MHz ~ 1GHz		
MODE	B	SERIAL NO.	DVT000025C32754

ANTENNA POLARITY & TEST DISTANCE: HORIZONTAL AT 3 M								
NO.	FREQ. (MHz)	EMISSION LEVEL (dBuV/m)	LIMIT (dBuV/m)	MARGIN (dB)	ANTENNA HEIGHT (m)	TABLE ANGLE (Degree)	RAW VALUE (dBuV)	CORRECTION FACTOR (dB/m)
1	53.28	13.6 QP	40.0	-26.4	1.05 H	287	26.70	-13.14
2	117.30	20.5 QP	43.5	-23.0	1.13 H	208	36.36	-15.86
3	191.99	17.8 QP	43.5	-25.7	1.24 H	72	33.64	-15.86
4	264.74	18.7 QP	46.0	-27.3	1.07 H	236	31.55	-12.82
5	444.19	19.1 QP	46.0	-26.9	1.05 H	330	27.52	-8.46
6	599.39	24.0 QP	46.0	-22.0	1.00 H	98	29.34	-5.35
ANTENNA POLARITY & TEST DISTANCE: VERTICAL AT 3 M								
NO.	FREQ. (MHz)	EMISSION LEVEL (dBuV/m)	LIMIT (dBuV/m)	MARGIN (dB)	ANTENNA HEIGHT (m)	TABLE ANGLE (Degree)	RAW VALUE (dBuV)	CORRECTION FACTOR (dB/m)
1	80.44	20.7 QP	40.0	-19.3	1.08 V	238	38.54	-17.86
2	109.54	22.1 QP	43.5	-21.4	1.05 V	23	38.59	-16.49
3	191.99	23.6 QP	43.5	-19.9	1.23 V	75	39.42	-15.86
4	242.43	25.1 QP	46.0	-20.9	1.07 V	201	38.96	-13.89
5	379.20	17.0 QP	46.0	-29.0	1.06 V	297	26.82	-9.80
6	614.91	24.8 QP	46.0	-21.2	1.02 V	23	29.76	-5.00

REMARKS:

1. Emission Level(dBuV/m) = Raw Value(dBuV) + Correction Factor(dB/m)
2. Correction Factor(dB/m) = Antenna Factor(dB/m) + Cable Factor(dB) – Pre-Amplifier Factor(dB)
3. The other emission levels were very low against the limit.
4. Margin value = Emission Level – Limit value



A D T

CHANNEL	TX Channel 78	DETECTOR FUNCTION	Quasi-Peak
FREQUENCY RANGE	30MHz ~ 1GHz		
MODE	B	SERIAL NO.	DVT000143C32754

ANTENNA POLARITY & TEST DISTANCE: HORIZONTAL AT 3 M								
NO.	FREQ. (MHz)	EMISSION LEVEL (dBuV/m)	LIMIT (dBuV/m)	MARGIN (dB)	ANTENNA HEIGHT (m)	TABLE ANGLE (Degree)	RAW VALUE (dBuV)	CORRECTION FACTOR (dB/m)
1	47.46	14.0 QP	40.0	-26.0	1.02 H	174	27.73	-13.70
2	116.33	18.7 QP	43.5	-24.8	1.06 H	202	34.68	-15.94
3	190.05	22.3 QP	43.5	-21.2	1.19 H	266	37.94	-15.67
4	349.13	16.8 QP	46.0	-29.3	1.21 H	274	27.34	-10.59
5	468.44	21.2 QP	46.0	-24.8	1.08 H	237	29.17	-8.00
6	597.45	23.9 QP	46.0	-22.1	1.00 H	266	29.20	-5.33
ANTENNA POLARITY & TEST DISTANCE: VERTICAL AT 3 M								
NO.	FREQ. (MHz)	EMISSION LEVEL (dBuV/m)	LIMIT (dBuV/m)	MARGIN (dB)	ANTENNA HEIGHT (m)	TABLE ANGLE (Degree)	RAW VALUE (dBuV)	CORRECTION FACTOR (dB/m)
1	93.05	17.2 QP	43.5	-26.3	1.20 V	53	36.20	-18.98
2	116.33	19.3 QP	43.5	-24.2	1.07 V	212	35.26	-15.94
3	191.02	17.9 QP	43.5	-25.6	1.12 V	190	33.66	-15.77
4	242.43	21.5 QP	46.0	-24.5	1.04 V	200	35.39	-13.89
5	607.15	25.7 QP	46.0	-20.3	1.10 V	25	30.88	-5.18
6	771.08	25.7 QP	46.0	-20.3	1.00 V	9	27.86	-2.13

REMARKS:

1. Emission Level(dBuV/m) = Raw Value(dBuV) + Correction Factor(dB/m)
2. Correction Factor(dB/m) = Antenna Factor(dB/m) + Cable Factor(dB) – Pre-Amplifier Factor(dB)
3. The other emission levels were very low against the limit.
4. Margin value = Emission Level – Limit value

4.2 CONDUCTED EMISSION MEASUREMENT

4.2.1 LIMITS OF CONDUCTED EMISSION MEASUREMENT

FREQUENCY OF EMISSION (MHz)	CONDUCTED LIMIT (dB μ V)	
	Quasi-peak	Average
0.15 ~ 0.5	66 to 56	56 to 46
0.5 ~ 5	56	46
5 ~ 30	60	50

- NOTE:** 1. The lower limit shall apply at the transition frequencies.
 2. The limit decreases in line with the logarithm of the frequency in the range of 0.15 to 0.50MHz.

4.2.2 TEST INSTRUMENTS

DESCRIPTION & MANUFACTURER	MODEL NO.	SERIAL NO.	CALIBRATED DATE	CALIBRATED UNTIL
ROHDE & SCHWARZ Test Receiver	ESCS 30	100276	Jan. 07, 2013	Jan. 06, 2014
ROHDE & SCHWARZ Artificial Mains Network (for EUT)	ESH3-Z5	100219	Nov. 28, 2012	Nov. 27, 2013
LISN With Adapter (for EUT)	AD10	C10Ada-001	Nov. 28, 2012	Nov. 27, 2013
ROHDE & SCHWARZ Artificial Mains Network (for peripherals)	ESH3-Z5	100218	Dec. 05, 2012	Dec. 04, 2013
Software	ADT_Cond_V7.3.7	NA	NA	NA
Software	ADT_ISN_V7.3.7	NA	NA	NA
RF cable (JYEBAO)	5D-FB	Cable-C10.01	Feb. 19, 2013	Feb. 18, 2014
SUHNER Terminator (For ROHDE & SCHWARZ LISN)	65BNC-5001	E1-010773	Feb. 06, 2013	Feb. 05, 2014

- NOTE:** 1. The calibration interval of the above test instruments is 12 months and the calibrations are traceable to NML/ROC and NIST/USA.
 2. The test was performed in Shielded Room No. 10.
 3. The VCCI Site Registration No. C-1852.

4.2.3 TEST PROCEDURES

- a. The EUT was placed 0.4 meters from the conducting wall of the shielded room with EUT being connected to the power mains through a line impedance stabilization network (LISN). Other support units were connected to the power mains through another LISN. The two LISNs provide 50 ohm/ 50uH of coupling impedance for the measuring instrument.
- b. Both lines of the power mains connected to the EUT were checked for maximum conducted interference.
- c. The frequency range from 150kHz to 30MHz was searched. Emission levels under (Limit - 20dB) was not recorded.

NOTE: All modes of operation were investigated and the worst-case emissions are reported.

4.2.4 DEVIATION FROM TEST STANDARD

No deviation.

4.2.5 TEST SETUP

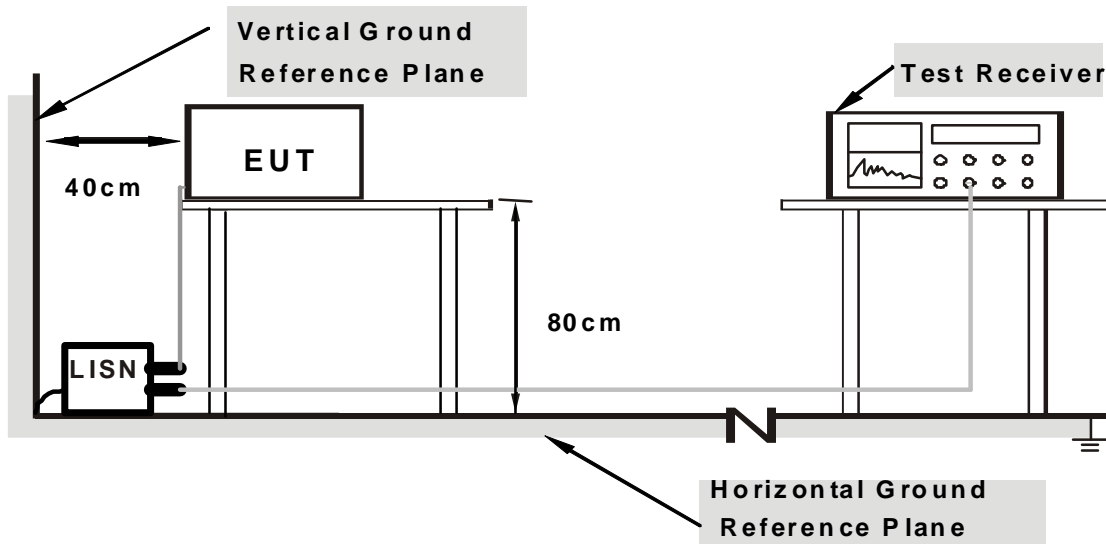

Note: Support units were connected to second LISN.

For the actual test configuration, please refer to the attached file (Test Setup Photo).

4.2.6 EUT OPERATING CONDITIONS

- a. Turn on the power of all equipment.
- b. Surface ran a test program (provided by manufacture) to enable EUT under transmitting condition at specific channel continuously.
- c. Set the EUT under transmitting and charging condition.



A D T

4.2.7 TEST RESULTS

CONDUCTED WORST-CASE DATA

PHASE	Line 1	6dB BANDWIDTH	9kHz
MODE	A	SERIAL NO.	DVT000407C32754

No	Freq. [MHz]	Corr. Factor (dB)	Reading Value		Emission Level		Limit		Margin	
			[dB (uV)]		[dB (uV)]		[dB (uV)]		(dB)	
			Q.P.	AV.	Q.P.	AV.	Q.P.	AV.	Q.P.	AV.
1	0.15000	0.13	54.13	35.12	54.26	35.25	66.00	56.00	-11.74	-20.75
2	0.18704	0.14	45.65	28.22	45.79	28.36	64.17	54.17	-18.38	-25.81
3	0.23594	0.15	38.83	17.29	38.98	17.44	62.24	52.24	-23.26	-34.80
4	3.03906	0.28	28.58	27.57	28.86	27.85	56.00	46.00	-27.14	-18.15
5	3.64844	0.30	28.06	26.43	28.36	26.73	56.00	46.00	-27.64	-19.27
6	10.96484	0.69	17.17	10.07	17.86	10.76	60.00	50.00	-42.14	-39.24
7	15.74609	0.93	20.04	14.10	20.97	15.03	60.00	50.00	-39.03	-34.97

REMARKS:

1. Q.P. and AV. are abbreviations of quasi-peak and average individually.
2. The emission levels of other frequencies were very low against the limit.
3. Margin value = Emission Level – Limit value
4. Correction Factor = Insertion loss + Cable loss
5. Emission Level = Correction Factor + Reading Value

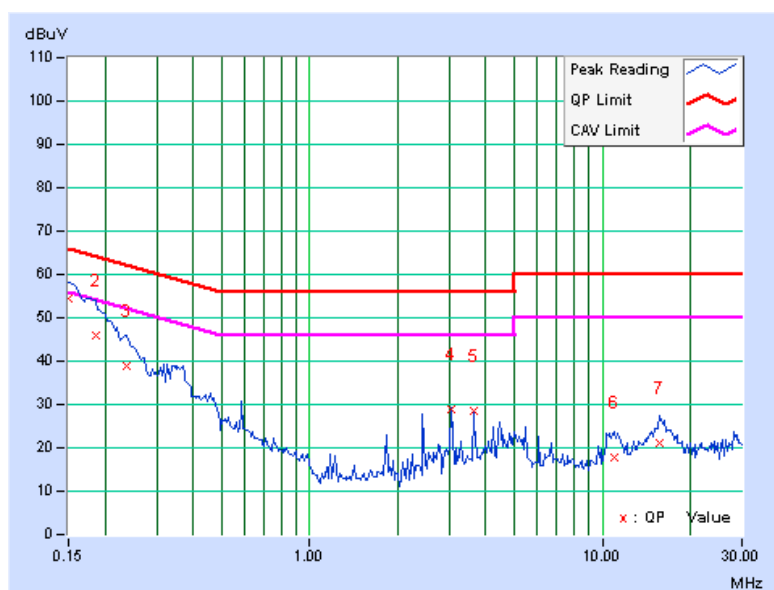



A D T

PHASE	Line 2	6dB BANDWIDTH	9kHz
MODE	A	SERIAL NO.	DVT000407C32754

No	Freq. [MHz]	Corr. Factor (dB)	Reading Value		Emission Level		Limit		Margin	
			[dB (uV)]		[dB (uV)]		[dB (uV)]		(dB)	
			Q.P.	AV.	Q.P.	AV.	Q.P.	AV.	Q.P.	AV.
1	0.15509	0.11	53.50	34.13	53.61	34.24	65.72	55.72	-12.12	-21.49
2	0.35421	0.13	32.37	13.65	32.50	13.78	58.86	48.86	-26.36	-35.08
3	0.58359	0.14	26.16	25.50	26.30	25.64	56.00	46.00	-29.70	-20.36
4	3.04034	0.23	28.21	26.92	28.44	27.15	56.00	46.00	-27.56	-18.85
5	15.60156	0.66	19.19	13.28	19.85	13.94	60.00	50.00	-40.15	-36.06
6	29.19141	0.94	17.44	13.30	18.38	14.24	60.00	50.00	-41.62	-35.76

REMARKS:

1. Q.P. and AV. are abbreviations of quasi-peak and average individually.
2. The emission levels of other frequencies were very low against the limit.
3. Margin value = Emission Level – Limit value
4. Correction Factor = Insertion loss + Cable loss
5. Emission Level = Correction Factor + Reading Value

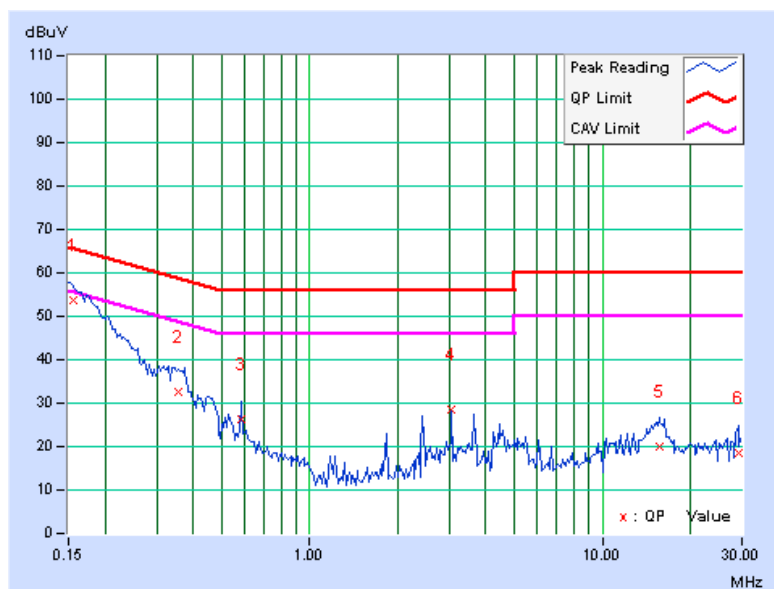

4.3 NUMBER OF HOPPING FREQUENCY USED

4.3.1 LIMIT OF HOPPING FREQUENCY USED

At least 15 channels frequencies, and should be equally spaced.

4.3.2 TEST SETUP

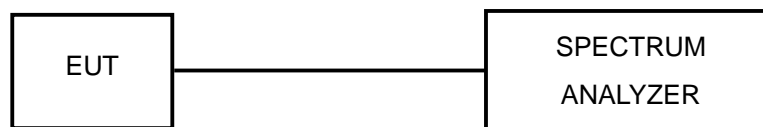

4.3.3 TEST INSTRUMENTS

Refer to section 4.1.2 to get information of above instrument.

4.3.4 TEST PROCEDURES

- a. Check the calibration of the measuring instrument (SA) using either an internal calibrator or a known signal from an external generator.
- b. Turn on the EUT and connect its antenna terminal to measurement via a low loss cable. Then set it to any one measured frequency within its operating range and make sure the instrument is operated in its linear range.
- c. Set the SA on MaxHold Mode, and then keep the EUT in hopping mode. Record all the signals from each channel until each one has been recorded.
- d. Set the SA on View mode and then plot the result on SA screen.
- e. Repeat above procedures until all frequencies measured were complete.

4.3.5 DEVIATION FROM TEST STANDARD

No deviation.

4.3.6 TEST RESULTS

There are 79 hopping frequencies in the hopping mode. Please refer to next two pages for the test result. On the plots, it shows that the hopping frequencies are equally spaced.



A D T

MODE A
SERIAL NO.: DVT000137C32754

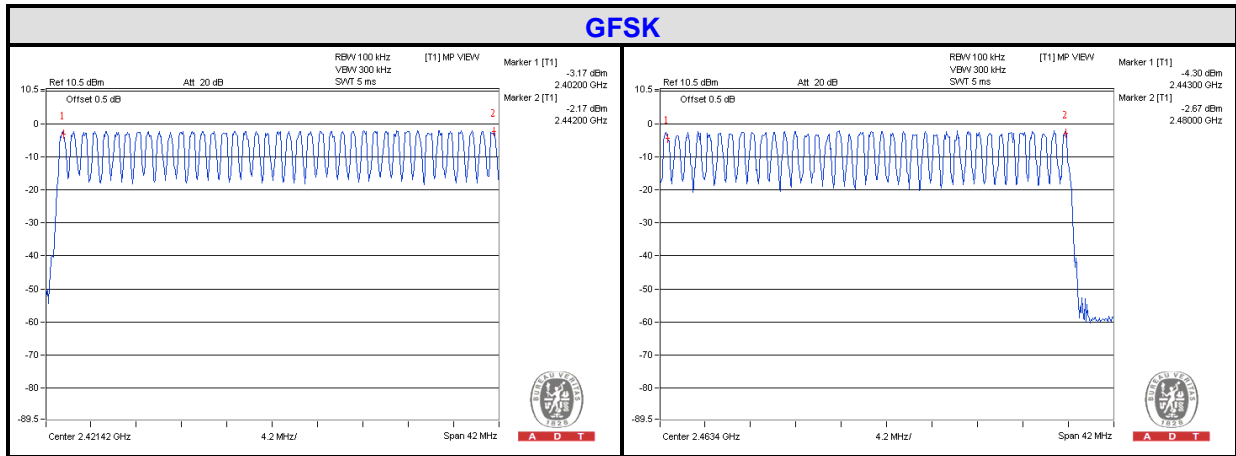

4.4 DWELL TIME ON EACH CHANNEL

4.4.1 LIMIT OF DWELL TIME USED

The average time of occupancy on any channel shall not be greater than 0.4 seconds within a period of 0.4 seconds multiplied by the number of hopping channels employed.

4.4.2 TEST SETUP

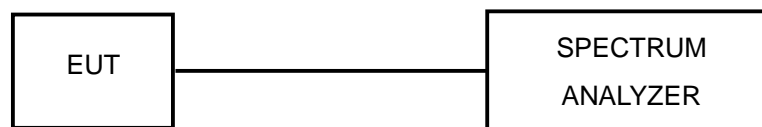

4.4.3 TEST INSTRUMENTS

Refer to section 4.1.2 to get information of above instrument.

4.4.4 TEST PROCEDURES

- a. Check the calibration of the measuring instrument (SA) using either an internal calibrator or a known signal from an external generator.
- b. Turn on the EUT and connect its antenna terminal to measurement via a low loss cable. Then set it to any one measured frequency within its operating range and make sure the instrument is operated in its linear range.
- c. Adjust the center frequency of SA on any frequency be measured and set SA to zero span mode. And then, set RBW and VBW of spectrum analyzer to proper value.
- d. Measure the time duration of one transmission on the measured frequency. And then plot the result with time difference of this time duration.
- e. Repeat above procedures until all different time-slot modes have been completed.

4.4.5 DEVIATION FROM TEST STANDARD

No deviation.



A D T

4.4.6 TEST RESULTS

MODE A

SERIAL NO.: DVT000137C32754

Mode	Number of transmission in a 31.6 (79Hopping*0.4)	Length of transmission time (msec)	Result (msec)	Limit (msec)
DH1	50 (times / 5 sec) * 6.32 = 316.00times	0.468	147.88800	400
DH3	27 (times / 5 sec) * 6.32 = 170.64 times	1.758	299.98512	400
DH5	17 (times / 5 sec) * 6.32 = 107.44 times	3.030	325.54320	400

NOTE: Test plots of the transmitting time slot are shown on below.

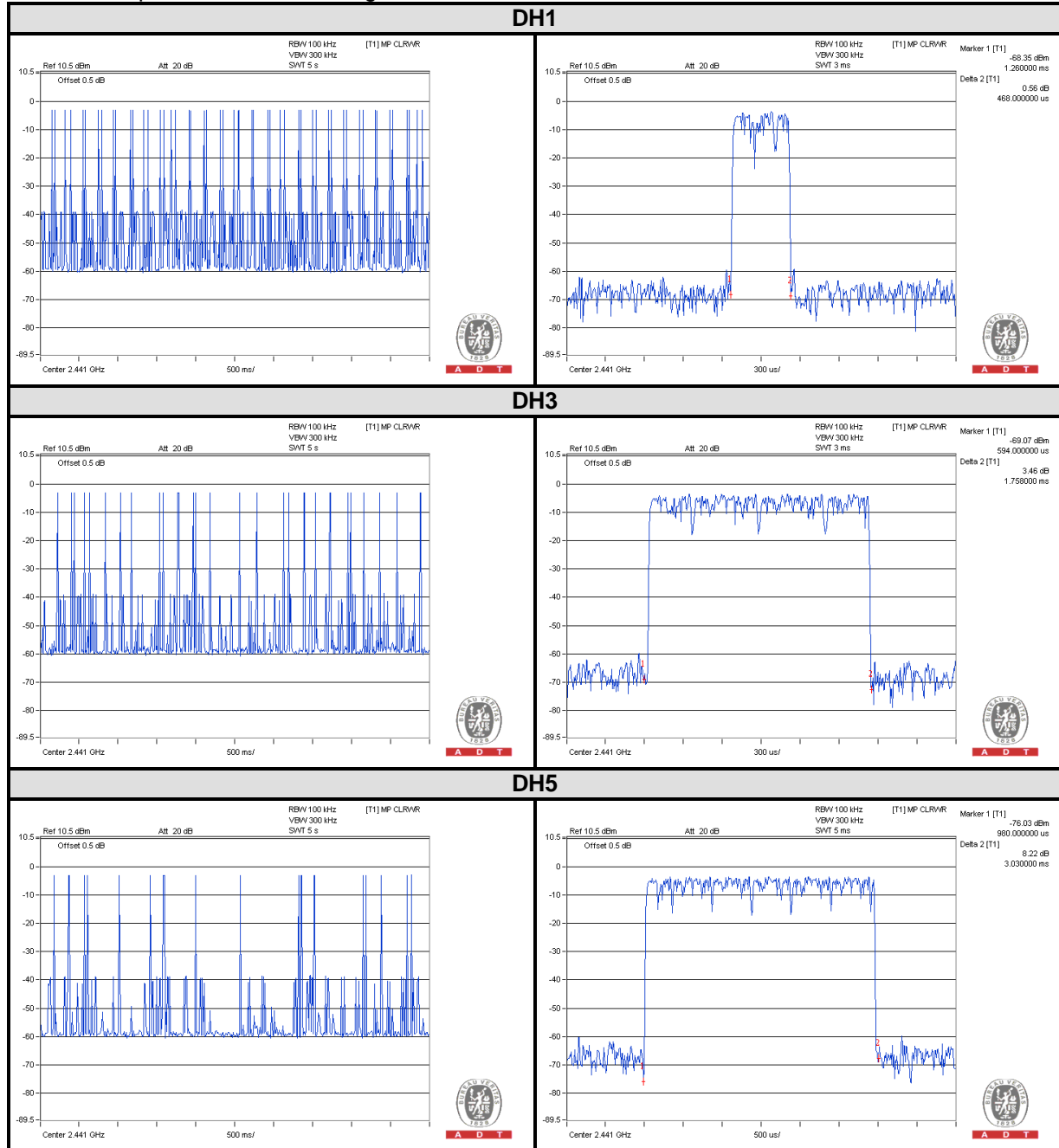

4.5 CHANNEL BANDWIDTH

4.5.1 LIMITS OF CHANNEL BANDWIDTH

For frequency hopping system operating in the 2400-2483.5MHz, If the 20dB bandwidth of hopping channel is greater than 25kHz, two-thirds 20dB bandwidth of hopping channel shall be a minimum limit for the hopping channel separation.

4.5.2 TEST SETUP

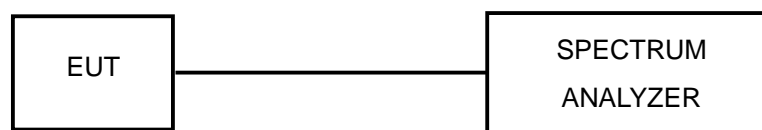

4.5.3 TEST INSTRUMENTS

Refer to section 4.1.2 to get information of above instrument.

4.5.4 TEST PROCEDURE

- a. Check the calibration of the measuring instrument using either an internal calibrator or a known signal from an external generator.
- b. Turn on the EUT and connect it to measurement instrument. Then set it to any one convenient frequency within its operating range. Set a reference level on the measuring instrument equal to the highest peak value.
- c. Measure the frequency difference of two frequencies that were attenuated 20dB from the reference level. Record the frequency difference as the emission bandwidth.
- d. Repeat above procedures until all frequencies measured were complete.

4.5.5 DEVIATION FROM TEST STANDARD

No deviation.

4.5.6 EUT OPERATING CONDITION

The software provided by client enabled the EUT to transmit and receive data at lowest, middle and highest channel frequencies individually.



A D T

4.5.7 TEST RESULTS

MODE A

SERIAL NO.: DVT000137C32754

CHANNEL	FREQUENCY (MHz)	20dB BANDWIDTH (MHz)
0	2402	1.11
39	2441	1.04
78	2480	1.03

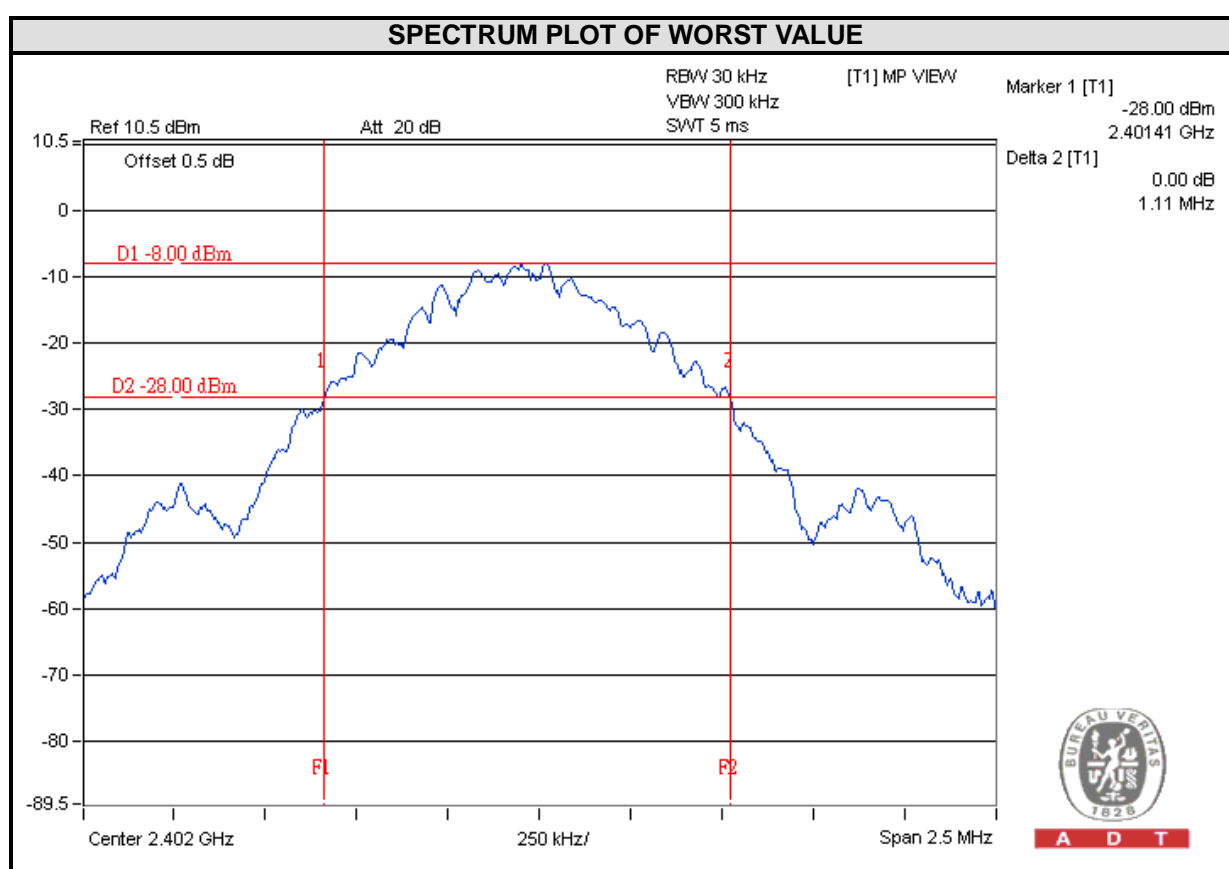

A D T

4.6 HOPPING CHANNEL SEPARATION

4.6.1 LIMIT OF HOPPING CHANNEL SEPARATION

At least 25kHz or two-third of 20dB hopping channel bandwidth (whichever is greater).

4.6.2 TEST SETUP

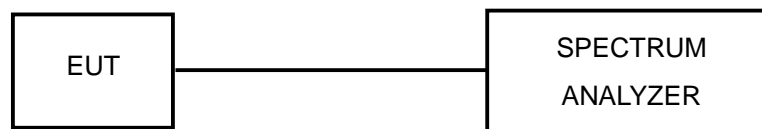

4.6.3 TEST INSTRUMENTS

Refer to section 4.1.2 to get information of above instrument.

4.6.4 TEST PROCEDURES

- a. Check the calibration of the measuring instrument using either an internal calibrator or a known signal from an external generator.
- b. Turn on the EUT and connect it to measurement instrument. Then set it to any one convenient frequency within its operating range.
- c. By using the MaxHold function record the separation of two adjacent channels.
- d. Measure the frequency difference of these two adjacent channels by SA MARK function. And then plot the result on SA screen.
- e. Repeat above procedures until all frequencies measured were complete.

4.6.5 DEVIATION FROM TEST STANDARD

No deviation.



A D T

4.6.6 TEST RESULTS

MODE A

SERIAL NO.: DVT000137C32754

CHANNEL	FREQUENCY (MHz)	ADJACENT CHANNEL SEPARATION (MHz)	20dB BANDWIDTH (MHz)	MINIMUM LIMIT (MHz)	PASS / FAIL
0	2402	1.00	1.11	0.74	PASS
39	2441	1.00	1.04	0.69	PASS
78	2480	1.01	1.03	0.69	PASS

NOTE: The minimum limit is two-third 20dB bandwidth.

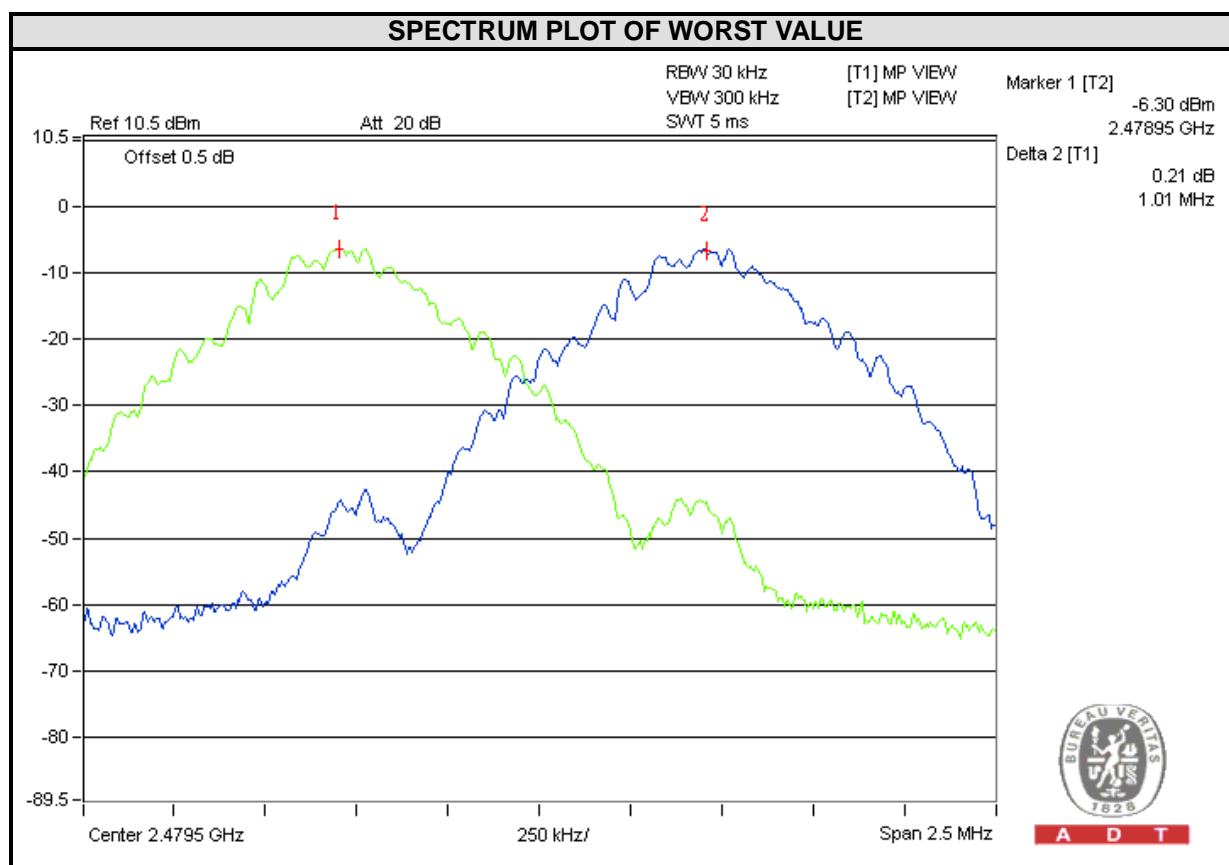

4.7 MAXIMUM OUTPUT POWER

4.7.1 LIMITS OF MAXIMUM OUTPUT POWER MEASUREMENT

The Maximum Output Power Measurement is 125mW.

4.7.2 TEST SETUP

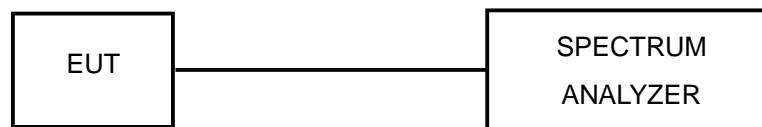

4.7.3 TEST INSTRUMENTS

Refer to section 4.1.2 to get information of above instrument.

4.7.4 TEST PROCEDURES

- Check the calibration of the measuring instrument using either an internal calibrator or a known signal from an external generator.
- Turn on the EUT and connect it to measurement instrument. Then set it to any one convenient frequency within its operating range. Set a reference level on the measuring instrument equal to the highest peak value.
- The center frequency of the spectrum analyzer is set to the fundamental frequency and using 3MHz RBW and 10 MHz VBW.
- Measure the captured power within the band and recording the plot.
- Repeat above procedures until all frequencies required were complete.

4.7.5 DEVIATION FROM TEST STANDARD

No deviation.

4.7.6 EUT OPERATING CONDITION

The software provided by client enabled the EUT to transmit and receive data at lowest, middle and highest channel frequencies individually.



A D T

4.7.7 TEST RESULTS

MODE A

SERIAL NO.: DVT000137C32754

CHANNEL	FREQUENCY (MHz)	OUTPUT POWER (dBm)	OUTPUT POWER (mW)	POWER LIMIT (mW)	PASS / FAIL
0	2402	-4.42	0.4	125	PASS
39	2441	-3.88	0.4	125	PASS
78	2480	-3.11	0.5	125	PASS

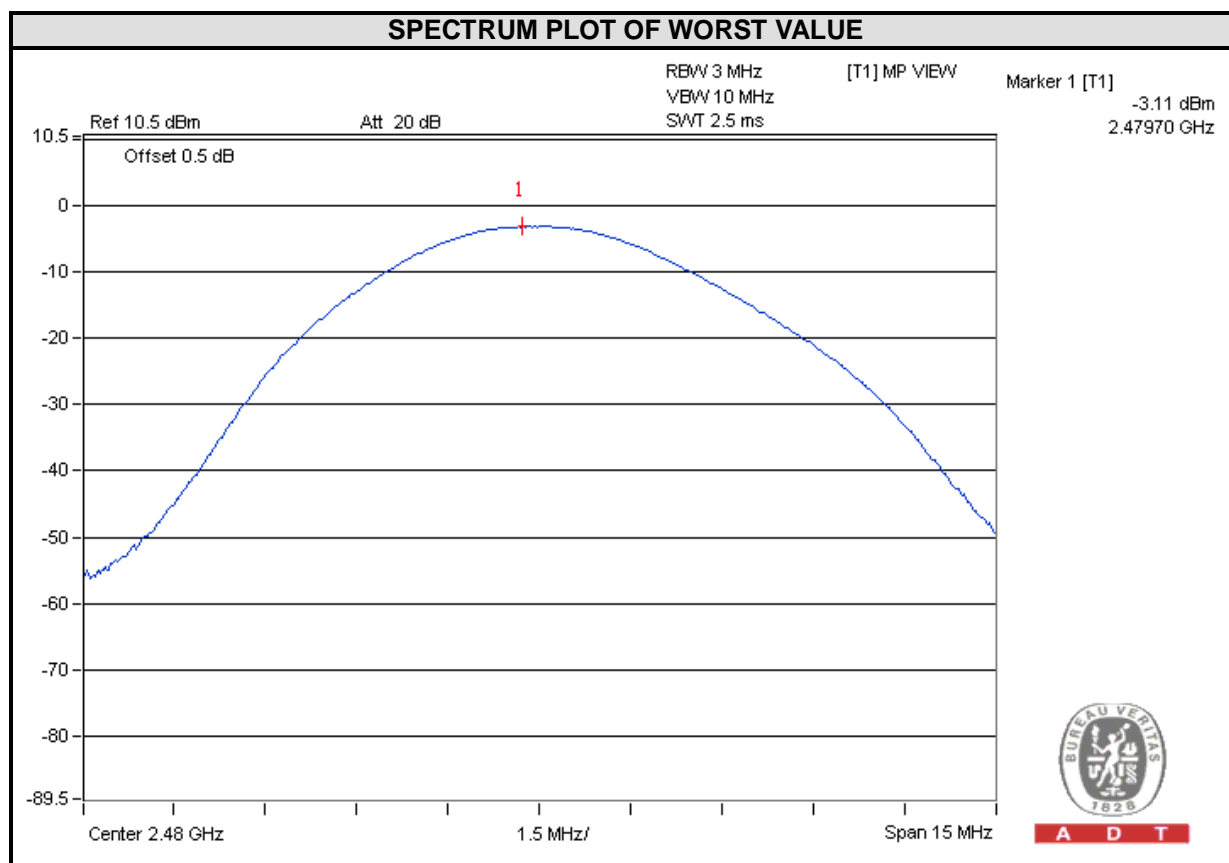

4.8 CONDUCTED OUT OF BAND EMISSION MEASUREMENT

4.8.1 LIMITS OF CONDUCTED OUT OF BAND EMISSION MEASUREMENT

Below -20dB of the highest emission level of operating band (in 100KHz RBW).

4.8.2 TEST INSTRUMENTS

Refer to section 4.1.2 to get information of above instrument.

4.8.3 TEST PROCEDURE

The transmitter output was connected to the spectrum analyzer via a low lose cable. Set both RBW and VBW of spectrum analyzer to 100 kHz & 300 kHz with suitable frequency span including 100 MHz bandwidth from band edge. The band edges was measured and recorded.

4.8.4 DEVIATION FROM TEST STANDARD

No deviation.

4.8.5 EUT OPERATING CONDITION

The software provided by client enabled the EUT to transmit and receive data at lowest, middle and highest channel frequencies individually.

4.8.6 TEST RESULTS

The spectrum plots are attached on the following images. D1 line indicates the highest level, D2 line indicates the 20dB offset below D1. It shows compliance with the requirement.



A D T

MODE A SERIAL NO.: DVT000137C32754

Hopping disabled_ Low Channel

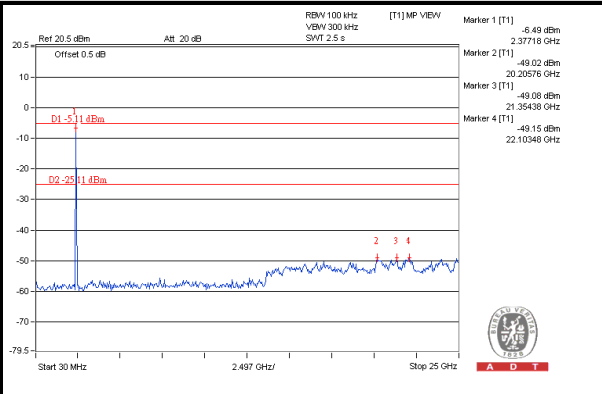
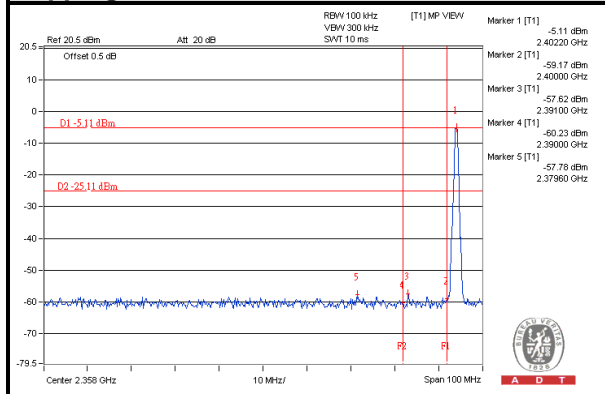

Hopping disabled_ High Channel

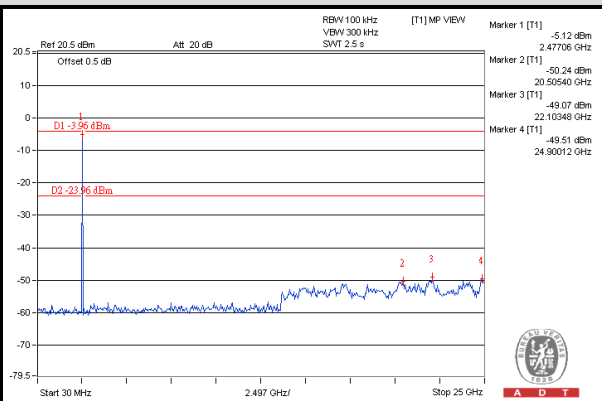
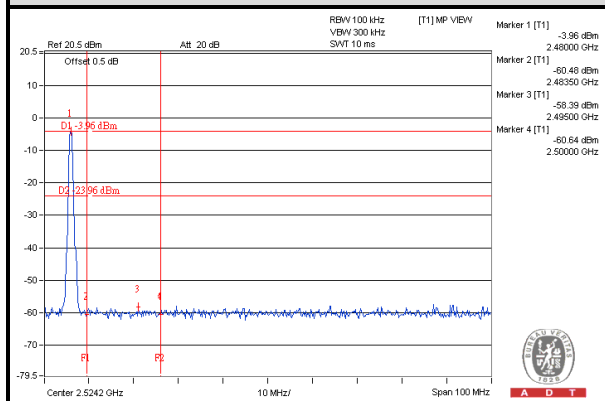

Hopping enabled_ Low Channel

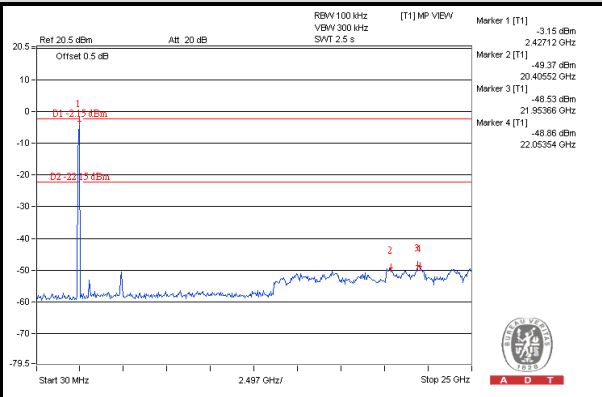
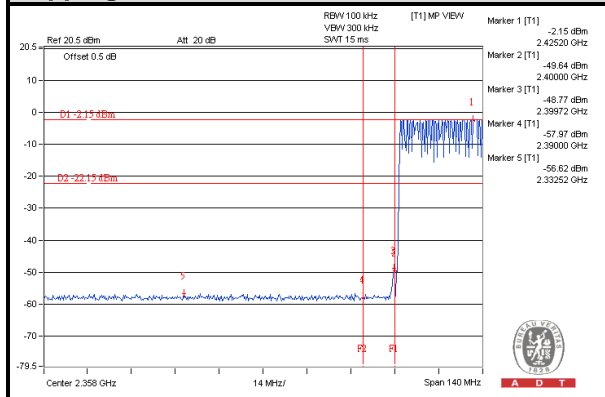

Hopping enabled_ High Channel

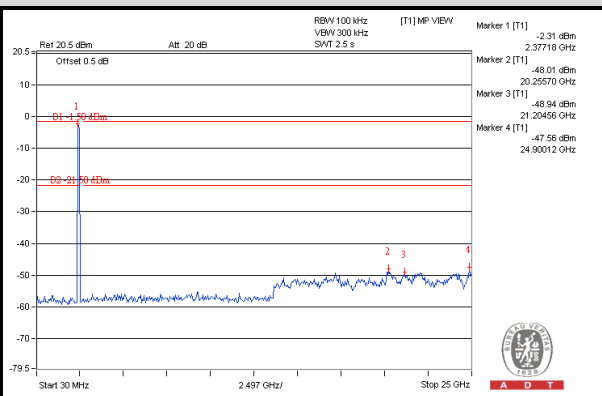
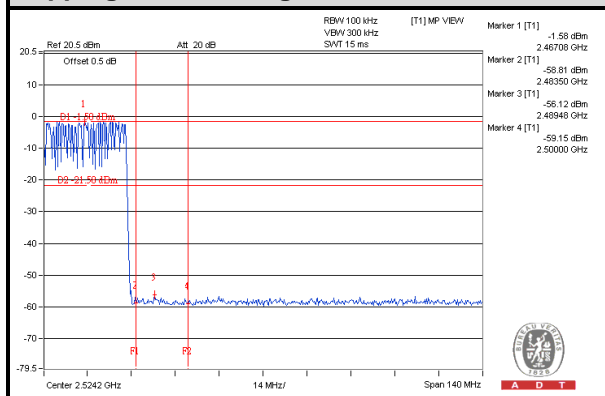



A D T

5. PHOTOGRAPHS OF THE TEST CONFIGURATION

Please refer to the attached file (Test Setup Photo).



6. INFORMATION ON THE TESTING LABORATORIES

We, Bureau Veritas Consumer Products Services (H.K.) Ltd., Taoyuan Branch, were founded in 1988 to provide our best service in EMC, Radio, Telecom and Safety consultation. Our laboratories are accredited and approved according to ISO/IEC 17025.

If you have any comments, please feel free to contact us at the following:

Linko EMC/RF Lab:

Tel: 886-2-26052180

Fax: 886-2-26051924

Hsin Chu EMC/RF Lab:

Tel: 886-3-5935343

Fax: 886-3-5935342

Hwa Ya EMC/RF/Safety Telecom Lab:

Tel: 886-3-3183232

Fax: 886-3-3270892

Email: service.adt@tw.bureauveritas.com

Web Site: www.bureauveritas-adt.com

The address and road map of all our labs can be found in our web site also.



A D T

7. APPENDIX A - MODIFICATIONS RECORDERS FOR ENGINEERING CHANGES TO THE EUT BY THE LAB

No modifications were made to the EUT by the lab during the test.

--- END ---