

TABLE OF CONTENTS LIST

APPLICANT: AZDEN CORPORATION

FCC ID: BZBAAVTH

TEST REPORT:

PAGE 1-2....COVER SHEET - GENERAL INFORMATION & TECHNICAL DESCR.
PAGE 3.....RF POWER OUTPUT
PAGE 4.....MODULATION CHARACTERISTICS
PAGE 5.....AUDIO FREQUENCY RESPONSE PLOT
PAGE 6.....MODULATION LIMITING PLOT - 300 Hz
PAGE 7.....MODULATION LIMITING PLOT - 3000 Hz
PAGE 8.....MODULATION LIMITING PLOT - 15000 Hz
PAGE 9.....OCCUPIED BANDWIDTH
PAGE 10.....OCCUPIED BANDWIDTH PLOT 25k
PAGE 11.....OCCUPIED BANDWIDTH PLOT 50k
PAGE 12.....METHOD OF MEASURING OCCUPIED BANDWIDTH
PAGE 13.....FIELD STRENGTH OF SPURIOUS EMISSIONS
PAGE 14.....METHOD OF MEASURING RADIATED SPURIOUS EMISSIONS
PAGE 15.....FREQUENCY STABILITY
PAGE 16-20...LIST OF TEST EQUIPMENT

EXHIBITS CONTAINING:

EXHIBIT 1.....FCC ID LABEL SAMPLE AND SKETCH OF LOCATION
EXHIBIT 2.....EXTERNAL PHOTO - FRONT VIEW
EXHIBIT 3.....EXTERNAL PHOTO - REAR VIEW
EXHIBIT 4.....EXTERNAL PHOTO - TOP VIEW
EXHIBIT 5.....INTERNAL PHOTO - COMPONENT VIEW
EXHIBIT 6.....INTERNAL PHOTO - COPPER VIEW
EXHIBIT 7.....BLOCK DIAGRAM
EXHIBIT 8.....SCHEMATIC
EXHIBIT 9.....USER'S MANUAL
EXHIBIT 10.....OPERATIONAL DESCRIPTION
EXHIBIT 11.....TUNING PROCEDURE
EXHIBIT 12.....LIST OF ACTIVE DEVICES
EXHIBIT 13.....TEST SETUP PHOTO

APPLICANT: AZDEN CORPORATION

FCC ID: BZBAAVTH

REPORT #: A\AZDEN\239CUT2\239CUT2TestReport.doc

TABLE OF CONTENTS LIST

GENERAL_INFORMATION_REQUIRED
FOR_TYPE_ACCEPTANCE

2.1033(c)(1)(2) AZDEN CORPORATION will manufacture the
FCCID: BZBAAVTH LOW POWER RADIO SERVICE
TRANSCEIVER in quantity, for use under FCC RULES
PART 95.

AZDEN CORPORATION
1-12-17 KAMI-REJAMKU
MITAKA, TOKYO, JAPAN 181

2.1033 (c) TECHNICAL_DESCRIPTION

2.1033(c)(3) Instruction book. A draft copy of the instruction
manual is included as EXHIBIT 9.

2.1033(c) (4) Type of Emission: 23K5F3E
95.631

Bn = 2M + 2DK
M = 6.5kHz
D = 5.25kHz
Bn = 2(6.5k)+ 2(5.25k)(1) = 23.5k

Authorized Bandwidth 25 kHz

2.1033(c)(5) Frequency Range: 216.0125 - 216.9875 MHz
95.629

2.1033(c)(6)(7) Power Output shall not exceed 100 mWatts ERP effective
95.1013(a) radiated power. There can be no provisions for
95.649 increasing the power or varying the power.

95.1013(c) The antenna is an integral part to the unit, it cannot
be removed without rendering the unit inoperative. In
order to remove the antenna the case must be unscrewed,
then the PCB assemblies must be removed then the
antenna can be removed.

2.1033(c)(8) DC Voltages and Current into Final Amplifier:
FINAL AMPLIFIER ONLY
Vce = 8.9 Volts DC Ice = 0.09A.
Pin = 0.08 Watts

APPLICANT: AZDEN CORPORATION

FCC ID: BZBAAVTH

REPORT #: A\AZDEN\239CUT2\239CUT2TestReport.doc

Page 1 of 17

- 2.1033(c)(9) Tune-up procedure. The tune-up procedure is included in exhibit 11.
- 2.1033(c)(10) Complete Circuit Diagrams: The circuit diagram is included as exhibit 8 of this report. The block diagram is included as exhibit 7 of this report.
- 2.1033(c)(11) A photograph or a drawing of the equipment identification label is included as exhibit No. 1.
- 2.1033(c)(12) Photographs(8"X10") of the equipment of sufficient clarity to reveal equipment construction and layout, including meters, labels for controls, including any view under shields - See exhibits 2-6.
- 2.1033(c)(13) Digital modulation is not allowed.
- 2.1033(c)(14) The data required by 2.1046 through 2.1057 is submitted below.

APPLICANT: AZDEN CORPORATION

FCC ID: BZBAAVTH

REPORT #: A\AZDEN\239CUT2\239CUT2TestReport.doc

Page 2 of 17

2.1046(a) RF power output.

95.1013(a) RF power is measured by measuring the radiated power at 3 meters and then replacing the transmitter with a signal generator to determine the effective radiated power. The ERP shall not exceed 100 mWatts.

MEASURED POWER OUTPUT = .006 Watts ERP

R.F. POWER OUTPUT
TEST SET UP

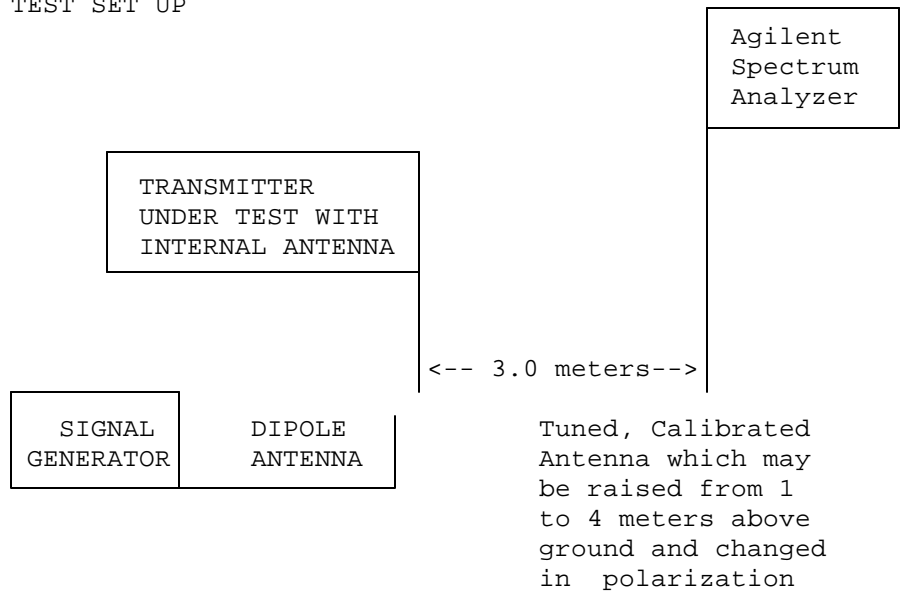

Equipment placed 80 cm above ground on a rotatable platform.

APPLICANT: AZDEN CORPORATION

FCC ID: BZBAAVTH

REPORT #: A\AZDEN\239CUT2\239CUT2TestReport.doc

Page 3 of 17

2.1047(a)(b) Modulation characteristics:

AUDIO FREQUENCY RESPONSE

The audio frequency response was measured in accordance with TIA/EIA Specification 603. The audio frequency response curve is shown on page 5.

The audio signal was fed into a dummy microphone circuit and into the microphone connector. The input required to produce 30 percent modulation level was measured.

2.1047(b) Audio input versus modulation

The audio input level needed for a particular percentage of modulation was measured in accordance with TIA/EIA Specification 603. The audio input curves versus modulation are shown in pages 6-8. Curves are provided for audio input frequencies of 300, 3000, and 15000 Hz.

AUDIO FREQUENCY RESPONSE PLOT

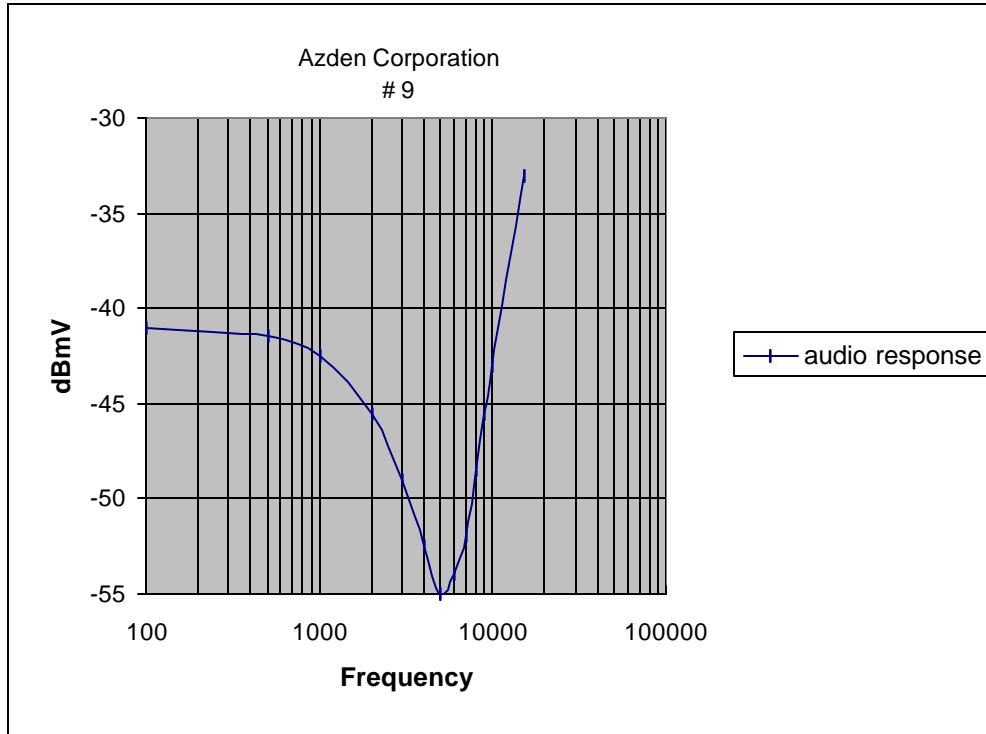

APPLICANT: AZDEN CORPORATION

FCC ID: BZBAAVTH

REPORT #: A\AZDEN\239CUT2\239CUT2TestReport.doc

Modulation Limiting
Azden Corporation
9

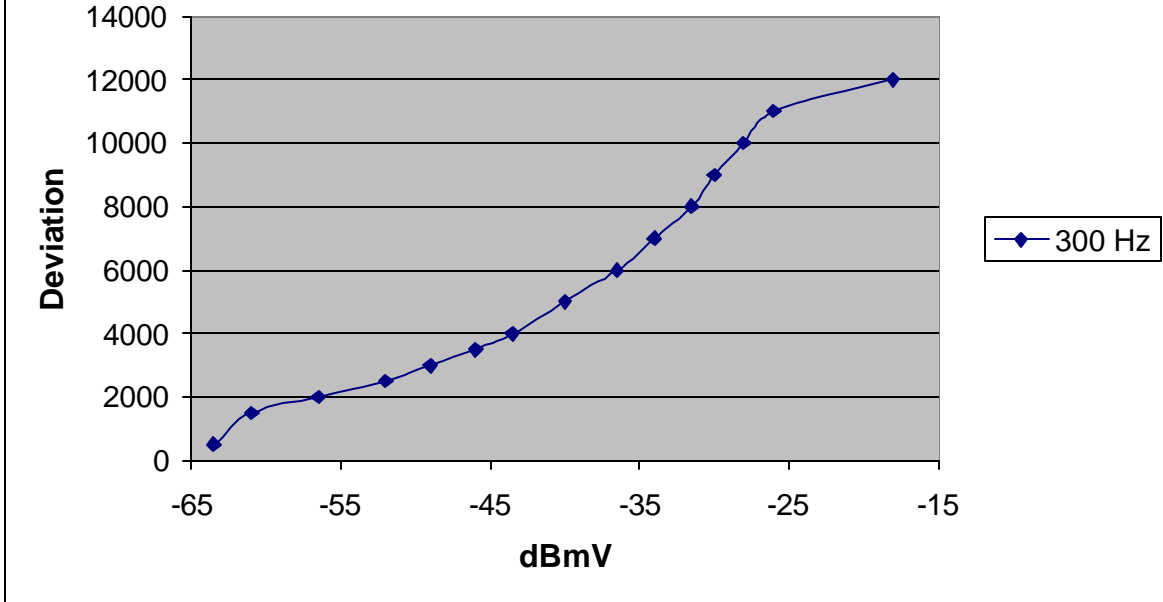

Modulation limiting 300 Hz

APPLICANT: AZDEN CORPORATION

FCC ID: BZBAAVTH

REPORT #: A\AZDEN\239CUT2\239CUT2TestReport.doc

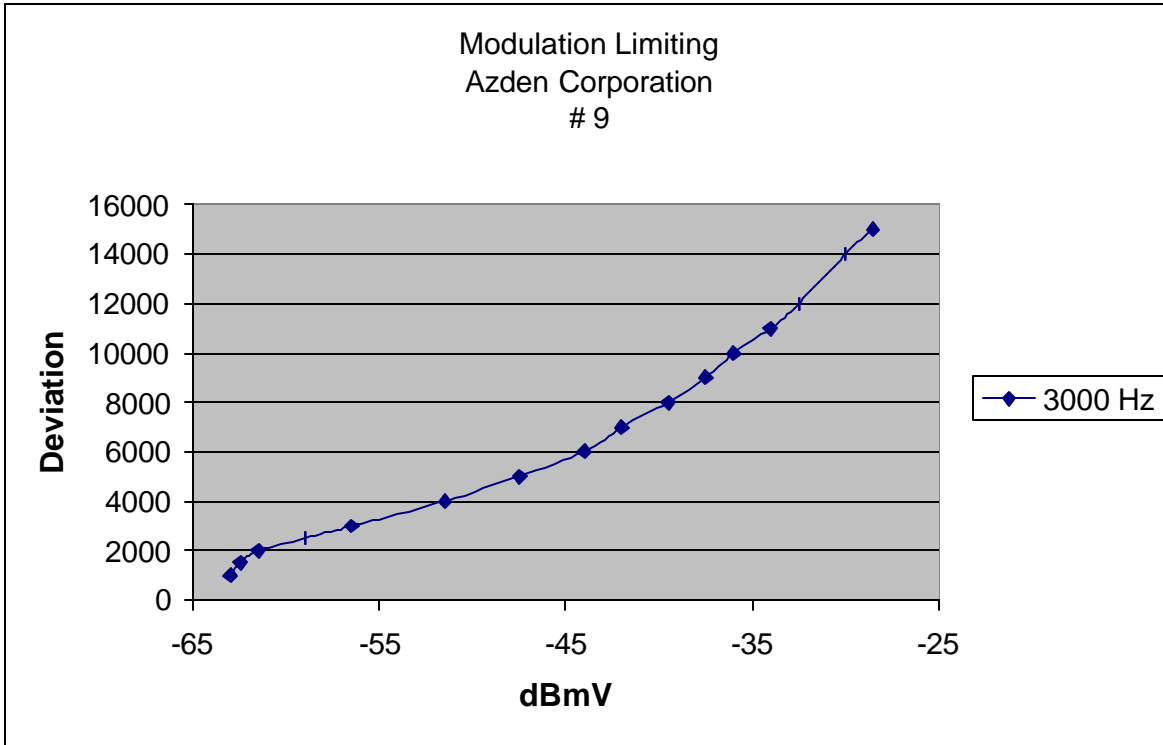

Modulation Limiting Plot 3000 Hz

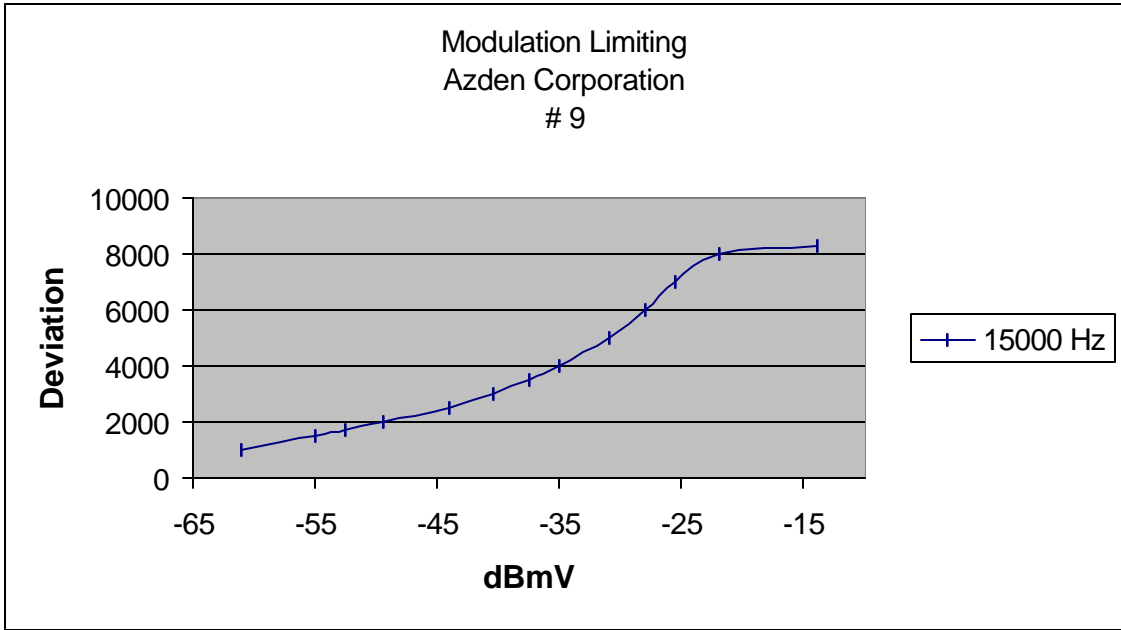

Modulation Limiting Plot 15000 Hz

APPLICANT: AZDEN CORPORATION

FCC ID: BZBAAVTH

REPORT #: A\AZDEN\239CUT2\239CUT2TestReport.doc

Page 8 of 17

2.1049(c) EMISSION BANDWIDTH:
95.635 (c)(1)(2)

(1) Emissions for LPRS transmitters operating on standard band channels (25 kHz) shall be attenuated below the unmodulated carrier in accordance with the following:

(i) Emissions 12.5 kHz to 22.5 kHz away from the channel center frequency: at least 30 dB; and

(ii) Emissions more than 22.5 kHz away from the channel center frequency: at least $43 + 10 \log(\text{carrier power in watts})$ dB.

(2) Emission for LPRS transmitters operating on extra band channels (50 kHz) shall be attenuated below the unmodulated carrier in accordance with the following:

(i) Emissions 25 kHz to 35 kHz from the channel center frequency: at least 30 dB; and

(ii) Emissions more than 35 kHz away from the channel center

(iii) frequency: at least $43 + 10 \log(\text{carrier power in watts})$ dB.

APPLICANT: AZDEN CORPORATION

FCC ID: BZBAAVTH

REPORT #: A\AZDEN\239CUT2\239CUT2TestReport.doc

Page 9 of 17

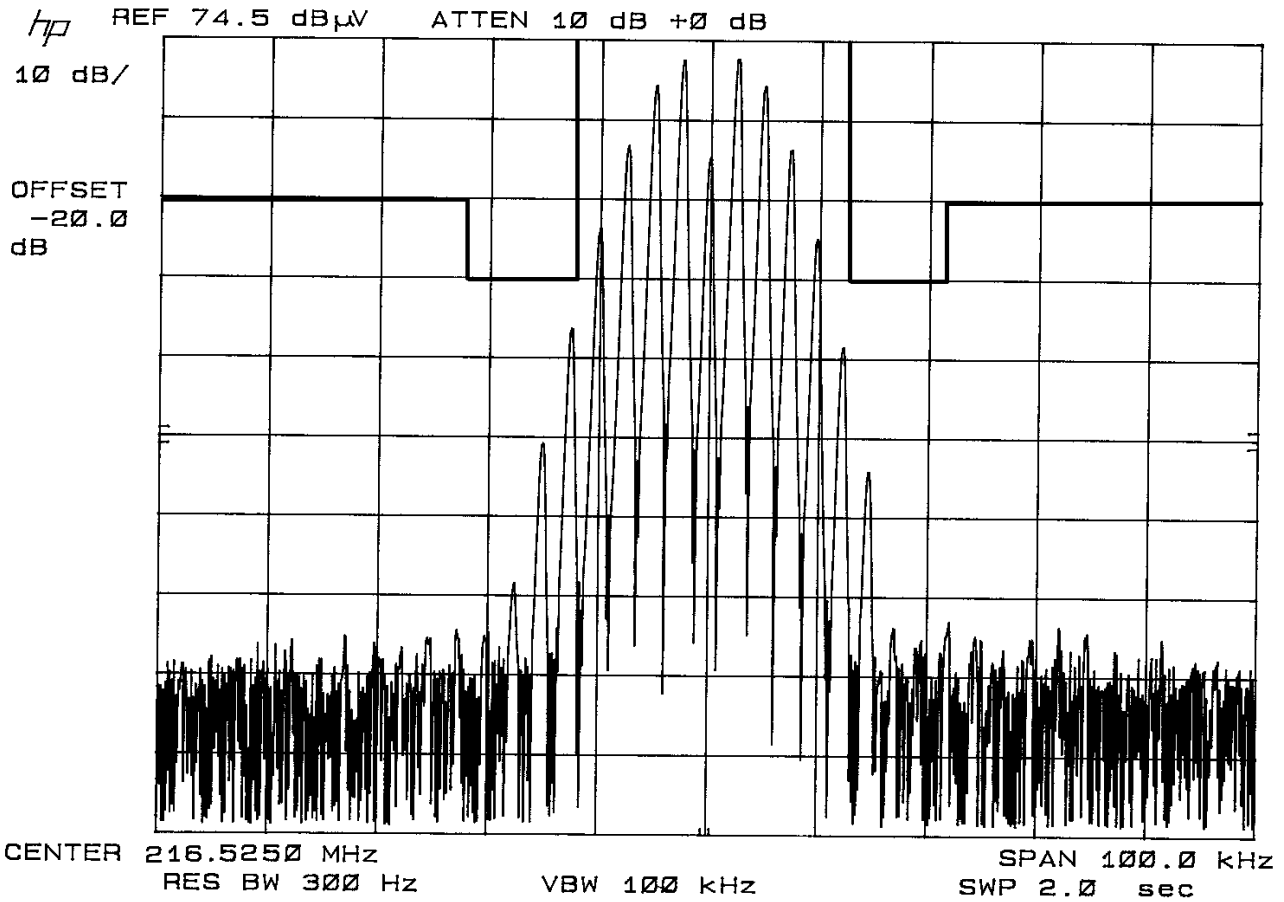

Occupied Bandwidth Plot 25 kHz channel

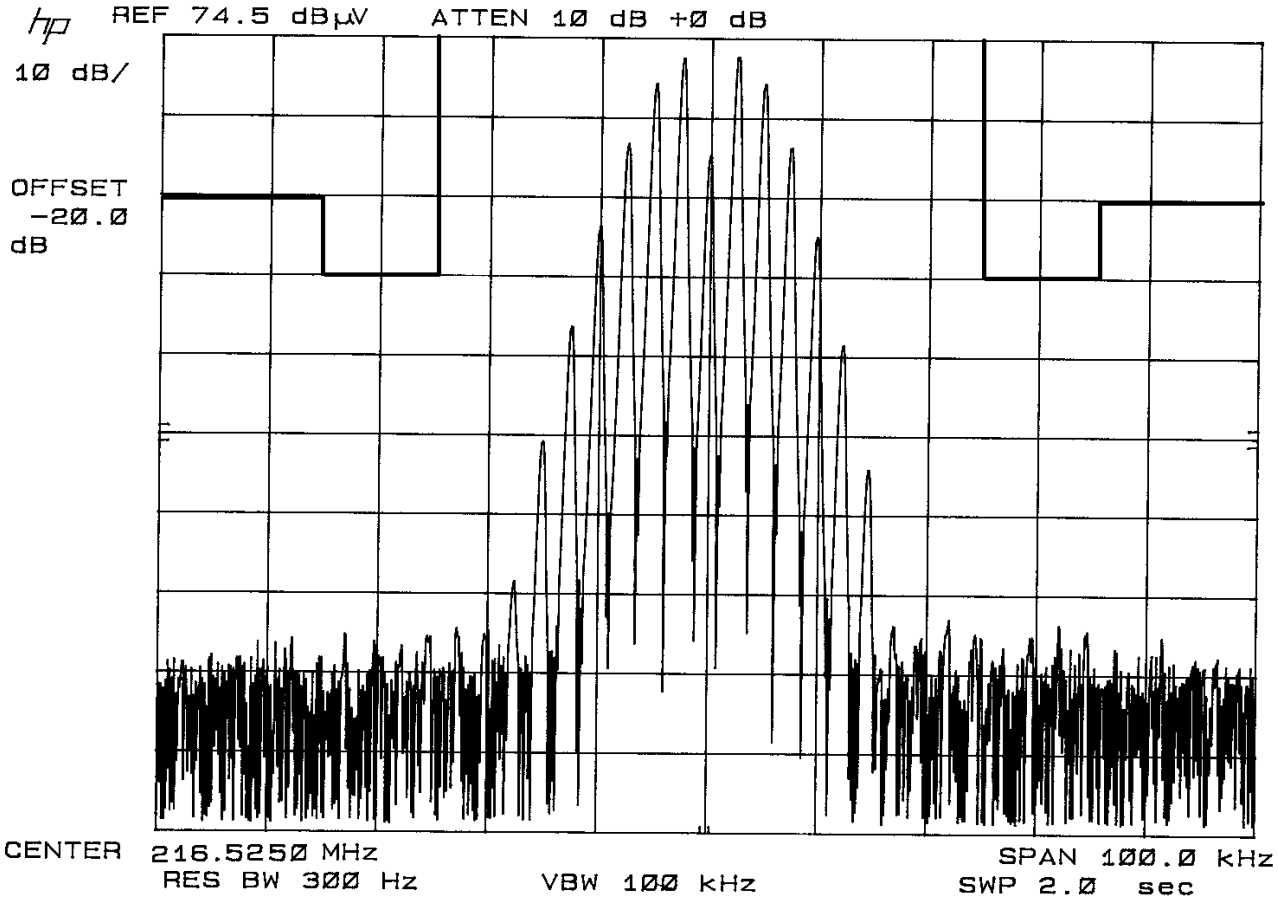

Occupied Bandwidth Plot 50 kHz channel

Radiotelephone transmitter with modulation limiter.

Test procedure diagram

OCCUPIED BANDWIDTH MEASUREMENT

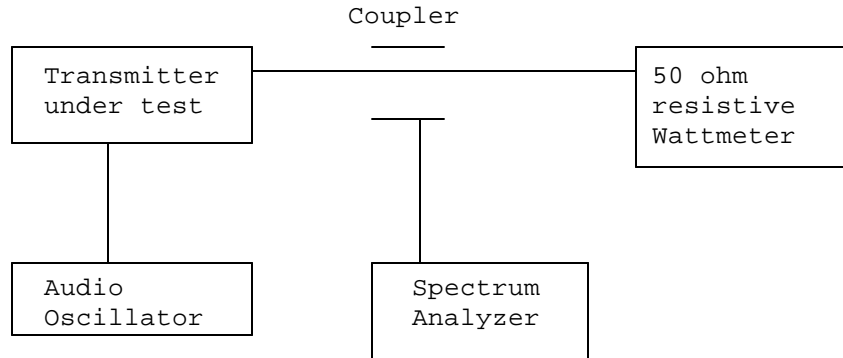

APPLICANT: AZDEN CORPORATION

FCC ID: BZBAAVTH

REPORT #: A\AZDEN\239CUT2\239CUT2TestReport.doc

Page 12 of 17

2.1051 Not Applicable, no antenna terminal allowed.

2.1053 UNWANTED RADIATION:
95.635(c)(1)

REQUIREMENTS: Emissions must be attenuated by at least the following below the output of the transmitter.

$$43 + 10\log(TP) = 43 + 10\log(.006) = 20.78 \text{ dB}$$

TEST DATA:

Emission Frequency MHz	dBc	Margin dB
216.80	0	0
433.60	45	24
650.40	**	**
867.20	**	**
1084.00	**	**
1300.80	**	**
1517.60	**	**
1734.40	**	**
1951.10	**	**
2168.00	**	**

**= Below FCC limit and below measurement capabilities.

MARGIN = (Field strength of Fund - 20.78 dB) - FS OF EMISSION

METHOD OF MEASUREMENT: The tabulated data shows the results of the radiated field strength of emissions test. The spectrum was scanned from 30 to at least the tenth harmonic of the fundamental. This test was conducted per TIA/EIA STANDARD 603 using the substitution method. Measurements were made at the open field test site of TIMCO ENGINEERING, INC. located at 849 NW State Road 45, Newberry, FL 32669.

APPLICANT: AZDEN CORPORATION

FCC ID: BZBAAVTH

REPORT #: A\AZDEN\239CUT2\239CUT2TestReport.doc

2.1053
95.635

UNWANTED RADIATION:

Method of Measuring Radiated Spurious Emissions

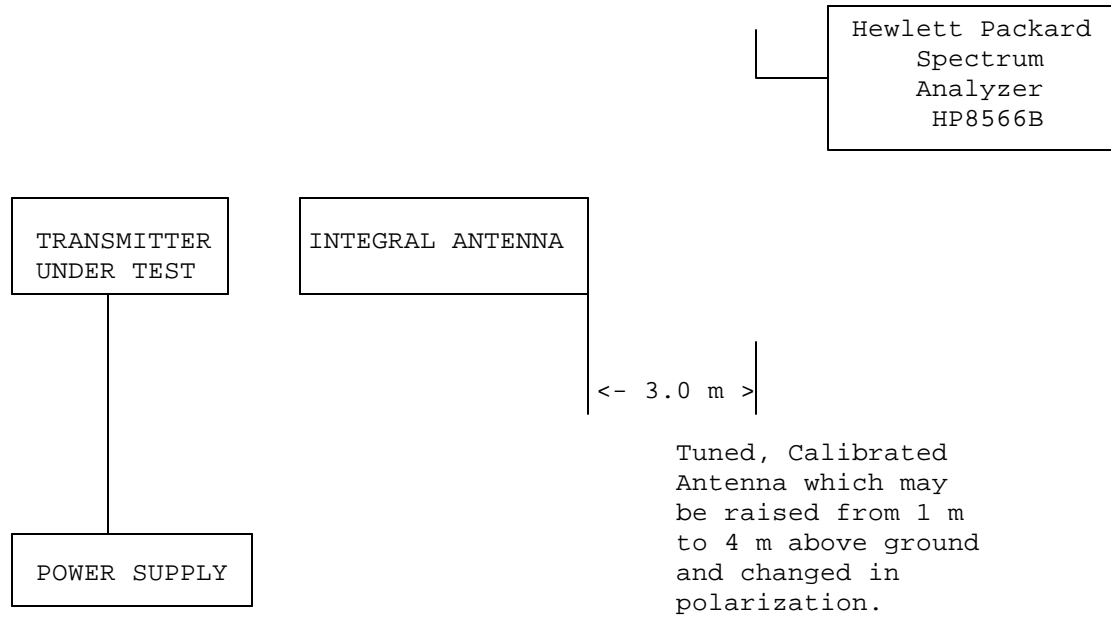

Equipment placed 80 cm above ground on a rotatable platform.

95.629(b)2) Frequency_stability:

Temperature and voltage tests were performed to verify that the frequency remains within the 0.0050%, 50 ppm specification limit. The test was conducted as follows: The transmitter was placed in the temperature chamber at 25 degrees C and allowed to stabilize for one hour. The transmitter was keyed ON for one minute during which four frequency readings were recorded at 15 second intervals. The worse case number was taken for temperature plotting. The assigned channel frequency was considered to be the reference frequency. The temperature was then reduced to -30 degrees C after which the transmitter was again allowed to stabilize for one hour. The transmitter was keyed ON for one minute, and again frequency readings were noted at 15 second intervals. The worst case number was recorded for temperature plotting. This procedure was repeated in 10 degree increments up to + 50 degrees C.

Readings were also taken at minus 15% of the battery voltage of 9 VDC.

MEASUREMENT DATA:

Assigned Frequency (Ref. Frequency): 216.801 121

TEMPERATURE °C	FREQUENCY MHz	PPM
REFERENCE_____	216.796 015	0.00
-30_____	216.797 025	-23.55
-20_____	216.797 702	-18.89
-10_____	216.799 366	-15.77
0_____	216.801 486	- 8.09
+10_____	216.801 297	1.68
+20_____	216.800 695	0.81
+30_____	216.799 857	- 1.96
+40_____	216.799 857	- 5.83
+50_____	216.798 679	-11.26

BATT. End-Point 7.65 Vdc 216.801 106 -0.07

RESULTS OF MEASUREMENTS: The maximum frequency variation over the temperature range was -23.55 to +1.68 ppm. The maximum frequency variation with voltage was -0.07 ppm.

APPLICANT: AZDEN CORPORATION

FCC ID: BZBAAVTH

REPORT #: A\AZDEN\239CUT2\239CUT2TestReport.doc

Equipment List

	DEVICE	MFGR	MODEL	SERNO	CAL/CHAR DATE	DUE DATE or STATUS
X	3-Meter OATS	TEI	N/A	N/A	Listed 12/22/99	12/22/02
	3/10-Meter OATS	TEI	N/A	N/A	Listed 3/26/01	3/26/04
X	Receiver, Beige Tower Spectrum Analyzer (Tan) RF Preselector (Tan) Quasi-Peak Adapter (Tan)	HP	8566B Opt 462	3138A07786 3144A20661	CAL 8/31/01	8/31/02
X		HP	85685A	3221A01400	CAL 8/31/01	8/31/02
X		HP	85650A	3303A01690	CAL 8/31/01	8/31/02
X		HP	8568B	2928A04729 2848A18049	CHAR 10/22/01	10/22/02
	Receiver, Blue Tower Spectrum Analyzer (Blue) RF Preselector (Blue) Quasi-Peak Adapter (Blue)	HP	85685A	2926A00983	CHAR 10/22/01	10/22/02
	Quasi-Peak Adapter (Blue)	HP	85650A	2811A01279	CHAR 10/22/01	10/22/02
	Biconnical Antenna	Electro-Metrics	BIA-25	1171	CAL 4/26/01	4/26/03
X	Biconnical Antenna	Eaton	94455-1	1096	CAL 10/1/01	10/1/02
	Biconnical Antenna	Eaton	94455-1	1057	CHAR 3/15/00	3/15/01
	BiconiLog Antenna	EMCO	3143	9409-1043		
X	Log-Periodic Antenna	Electro-Metrics	LPA-25	1122	CAL 10/2/01	10/2/02
	Log-Periodic Antenna	Electro-Metrics	EM-6950	632	CHAR 10/15/01	10/15/02
	Log-Periodic Antenna	Electro-Metrics	LPA-30	409	CHAR 10/16/01	10/16/02
	Dipole Antenna Kit	Electro-Metrics	TDA-30/1-4	152	CAL 3/21/01	3/21/02
	Dipole Antenna Kit	Electro-Metrics	TDA-30/1-4	153	CHAR 11/24/00	11/24/01

	DEVICE	MFGR	MODEL	SERNO	CAL/CHAR DATE	DUE DATE or STATUS
	Double-Ridged Horn Antenna	Electro-Metrics	RGA-180	2319	CAL 12/19/01	12/19/02
X	Horn Antenna	Electro-Metrics	EM-6961	6246	CAL 3/21/01	3/21/02
	Horn Antenna	ATM	19-443-6R	None	No Cal Required	
	Passive Loop Antenna	EMC Test Systems	EMCO 6512	9706-1211	CHAR 7/10/01	7/10/02
	Line Impedance Stabilization . . .	Electro-Metrics	ANS-25/2	2604	CAL 10/9/01	10/9/02
	Line Impedance Stabilization . . .	Electro-Metrics	EM-7820	2682	CAL 3/16/01	3/16/02
	Termaline Wattmeter	Bird Electronic Corporation	611	16405	CAL 5/25/99	(5/25/00)
	Termaline Wattmeter	Bird Electronic Corporation	6104	1926	CAL 12/12/01	12/12/02
	Oscilloscope	Tektronix	2230	300572	CHAR 2/1/01	2/1/02
X	Temperature Chamber	Tenney Engineering	TTRC	11717-7	CHAR 1/22/02	1/22/03
	AC Voltmeter	HP	400FL	2213A14499	CAL 10/9/01	10/9/02
	AC Voltmeter	HP	400FL	2213A14261	CHAR 10/15/01	10/15/02
	AC Voltmeter	HP	400FL	2213A14728	CHAR 10/15/01	10/15/02
X	Digital Multimeter	Fluke	77	35053830	CHAR 1/8/02	1/8/03
	Digital Multimeter	Fluke	77	43850817	CHAR 1/8/02	1/8/03
	Digital Multimeter	HP	E2377A	2927J05849	CHAR 1/8/02	1/8/03
	Multimeter	Fluke	FLUKE-77-3	79510405	CAL 9/26/01	9/26/02
	Peak Power Meter	HP	8900C	2131A00545	CHAR 1/26/01	1/26/02
	Digital Thermometer	Fluke	2166A	42032	CAL 1/16/02	1/16/03
	Thermometer	Traulsen	SK-128		CHAR 1/22/02	1/22/03

APPLICANT: AZDEN CORPORATION

FCC ID: BZBAAVTH

REPORT #: A\AZDEN\239CUT2\239CUT2TestReport.doc

	DEVICE	MFGR	MODEL	SERNO	CAL/CHAR DATE	DUE DATE or STATUS
X	Temp/Humidity gauge	EXTech	44577F	E000901	CHAR 1/22/02	1/22/03
X	Frequency Counter	HP	5352B	2632A00165	CAL 11/28/01	11/28/02
	Power Sensor	Agilent Technologies	84811A	2551A02705	CAL 1/26/01	1/26/02
	Injection Probe	Fischer Custom Communications	F-120-9A	270	CAL 6/1/01	6/1/02
	Service Monitor	IFR	FM/AM 500A	5182	CAL 11/22/00	11/22/01
	Comm. Serv. Monitor	IFR	FM/AM 1200S	6593	CAL 11/12/99	11/12/00
X	Signal Generator	HP	8640B	2308A21464	CAL 11/15/01	11/15/02
	Modulation Analyzer	HP	8901A	3435A06868	CAL 9/5/01	9/5/02
	Power Line Coupling/ Decoupling Network	Fischer Custom Communications	FCC-801- M2-16A	01048	CAL 8/29/01	8/29/02
	Power Line Coupling/ Decoupling Network	Fischer Custom Communications	FCC-801- M3-16A	01060	CAL 8/29/01	8/29/02
	VHF/UHF Current Probe	Fischer Custom Communications	F-52	130	CAL 8/30/01	8/30/02
	Passive Impedance Adapter	Fischer Custom Communications	FCC-801- 150-50-CDN	01117 & 01118	CAL 8/29/01	8/29/02
	Radiating Field Coil	Fischer Custom Communications	F-1000-4- 8/9/10-L-1M	9859	CAL 10/15/98	10/15/99
	Near Field Probe	HP	HP11940A	2650A02748	CHAR 2/1/01	2/1/02
	BandReject Filter	Lorch Microwave	5BR4-2400/ 60-N	Z1	CHAR 3/2/01	3/2/02
	BandReject Filter	Lorch Microwave	6BR6-2442/ 300-N	Z1	CHAR 3/2/01	3/2/02
	BandReject Filter	Lorch Microwave	5BR4-10525/ 900-S	Z1	CHAR 3/2/01	3/2/02
	High Pas Filter	Microlab	HA-10N		CHAR 10/4/01	10/4/02
X	Audio Oscillator	HP	653A	832-00260	CHAR 3/1/01	3/1/02

APPLICANT: AZDEN CORPORATION

FCC ID: BZBAAVTH

REPORT #: A\AZDEN\239CUT2\239CUT2TestReport.doc

	DEVICE	MFGR	MODEL	SERNO	CAL/CHAR DATE	DUE DATE or STATUS
	Frequency Counter	HP	5382A	1620A03535	CHAR 3/2/01	3/2/02
	Frequency Counter	HP	5385A	3242A07460	CHAR 12/11/01	12/11/02
	Preamplifier	HP	8449B-H02	3008A00372	CHAR 3/4/01	3/4/02
	Amplifier	HP	11975A	2738A01969	CHAR 3/1/01	3/1/02
	Egg Timer	Unk			CHAR 2/28/01	2/28/02
	Measuring Tape, 20M	Kraftixx	0631-20		CHAR 2/28/01	2/28/02
	Measuring Tape, 7.5M	Kraftixx	7.5M PROFI		CHAR 2/28/01	2/28/02
	EMC Immunity Test System	Keytek	CEMASTER	9810210		
	AC Power Source	California Instruments	1251RP	L05865		
	AC Power Source	California Instruments	PACS-1	X71484		
	Isotropic Field Probe	Amplifier Research	FP5000	22839		
	Isotropic Field Probe	Amplifier Research	FP5000	300103		
	Capacitor Clamp	Keytek	CM-CCL	9811359	No Cal Required	
	Amplifier	Amplifier Research	10W1000B	23117	No Cal Required	
	Field Monitor	Amplifier Research	FM5004	22288	No Cal Required	
	ELF Meter	F. W. Bell	4060	Not serialized		
	Coaxial Cable #51	Insulated Wire Inc.	NPS 2251-2880	Timco #51	CHAR 1/23/02	1/23/03
	Coaxial Cable #64	Semflex Inc.	60637	Timco #64	CHAR 1/24/02	1/24/03
	Coaxial Cable #65	General Cable Co.	E9917 RG233/U	Timco #65	CHAR 1/23/02	1/23/03
	Coaxial Cable #106	Unknown	Unknown	Timco #106	CHAR 1/23/02	1/23/03

APPLICANT: AZDEN CORPORATION

FCC ID: BZBAAVTH

REPORT #: A\AZDEN\239CUT2\239CUT2TestReport.doc