

XXXXE-090

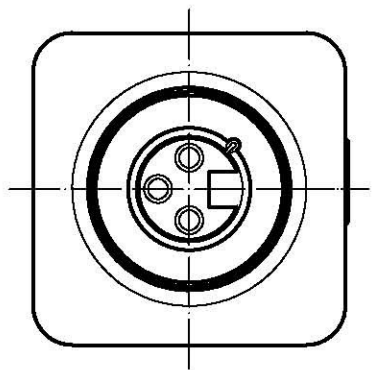

No.	DISCRIPTION	PART NUMBER	Q'TY	MATERIAL	FINISH	REMARK
1	TOP MOLD	060-35079-01	1	ABS BLACK		
2	BATTERY CASE	060-25088-01	1	ABS BLACK		
3	BATTERY COVER	060-35080-01	1	ABS BLACK		
4	BOTTOM COVER PROCESSING	060-25102-06	1	ABS BLACK	SILK-P	
5	SIDE PANEL	060-49115-04	1	A6063S-T5		
6	NAME PLATE	060-49117-01	2	ALP 0.5T	B-ALMITE	
7	XLR CONNECTOR	050-47517-01	1			NC3FX-SPEC
8	FRONT FILTER	060-48763-01	1			
9	M2X6 PAN SCREW	097-40079F05	4	SWR	MFZN2-B	

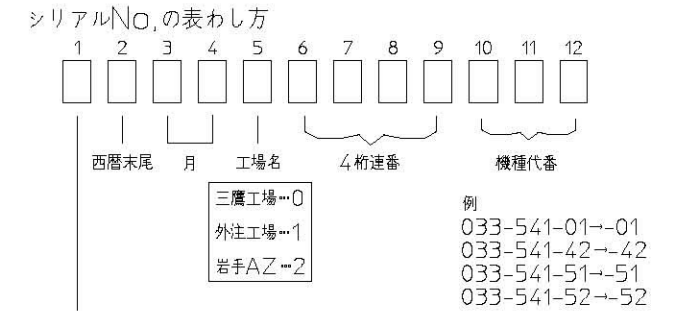
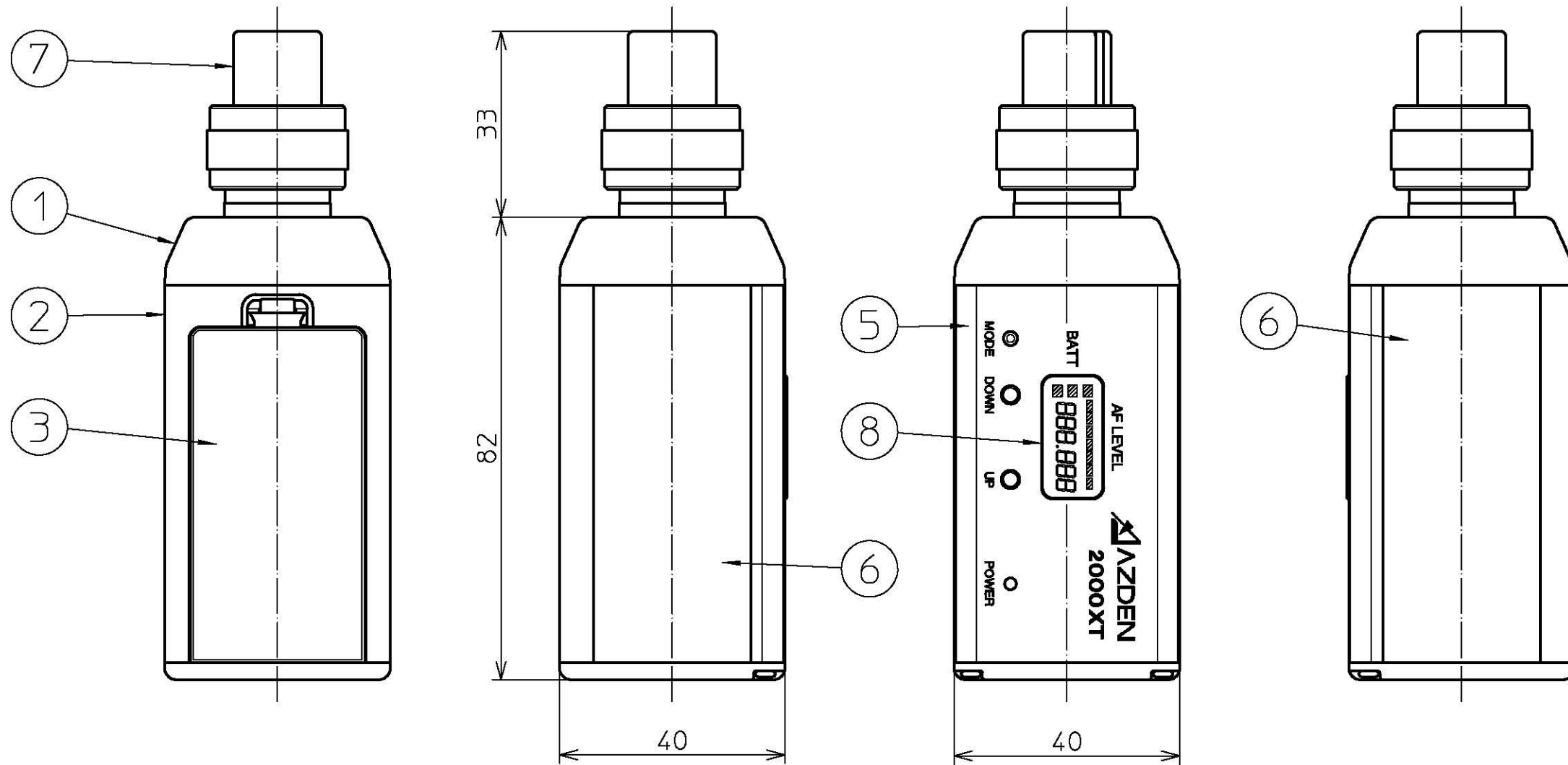

	RoHS	非RoHS
海外向け	G	無し
国内向け	無し	無し

本機種
033-541-01 海外向け RoHS G有り
033-541-42 海外向け RoHS G有り
033-541-51 海外向け RoHS G有り
033-541-52 海外向け RoHS G有り

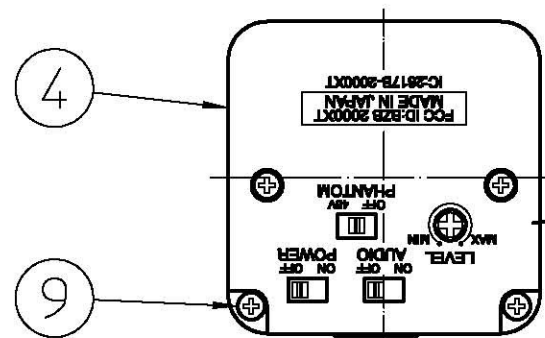

Label location

DRAWN	CHECKED	CHECKED	APPROVED	SCALE	ANGLE
池戸	F.木村			1/1	3rd
120210					UNIT mm

SYMBOL	REVISION RECORD	DATE	BY
MATERIAL	 アズデン 株式会社		
FINISH	TITLE 外形図 APPEARANCE		
USED ON	DRAWING NO		
033-543	060-3XXXX		