

060-35587

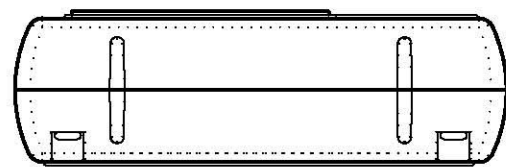
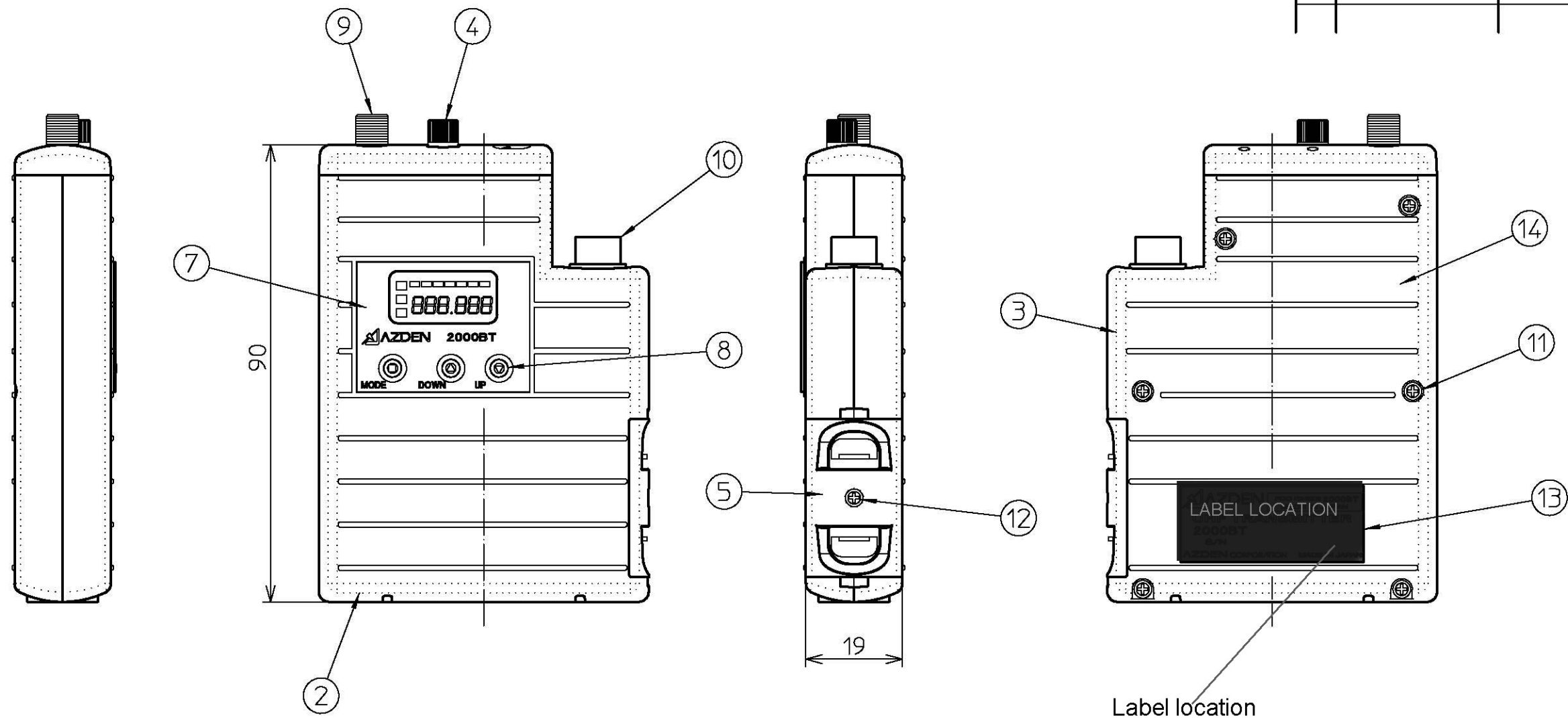
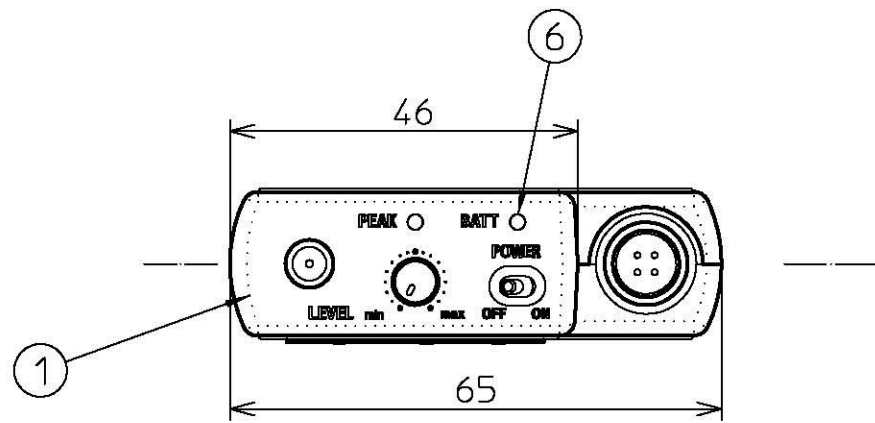

No.	DISCRIPTION	PART NUMBER	Q'TY	MATERIAL	FINISH
1	TOP PANEL	060-35361-02	1	ABS	SILK-P
2	FRONT CASE	060-25146-02	1	ADC-12	PAINT
3	REAR CASE	060-25147-02	1	ADC-12	PAINT
4	KNOB	060-49498-01	1	ABS	
5	BATTERY BASE	060-35364-01	1	ABS	
6	LED FILTER	060-49497-01	1	PMMA	
7	FRONT FILTER	060-49505-01	1	PMMA	SILK-P
8	BUTTON	060-49499-01	1	Si-RUBBER	
9	SMA CONNECTOR	050-47730-01	1		
10	CONNECTOR SN-8-4	050-45966-02	1		
11	M2x10(0-3) PAN SCREW	097-40079-09	6	SUS	
12	#2x5(0-3) PAN B-TITE	097-40027F06	1	SWRM	MFZn2-B
13	FCC LABEL	060-49753C01	1	ABS	
14	WIRE CLIP	060-49748-01	1	SUS-304	

DRAWN	CHECKED	CHECKED	APPROVED	SCALE	ANGLE
F.木村				1/1	3rd
110624					UNIT mm

SYMBOL	REVISION RECORD	DATE	BY
MATERIAL	 AZDEN CORPORATION アツデン 株式会社		
FINISH	TITLE 外形図 APPEARANCE		
USED ON	DRAWING NO		
033-542-01	060-35587		