

060-35174

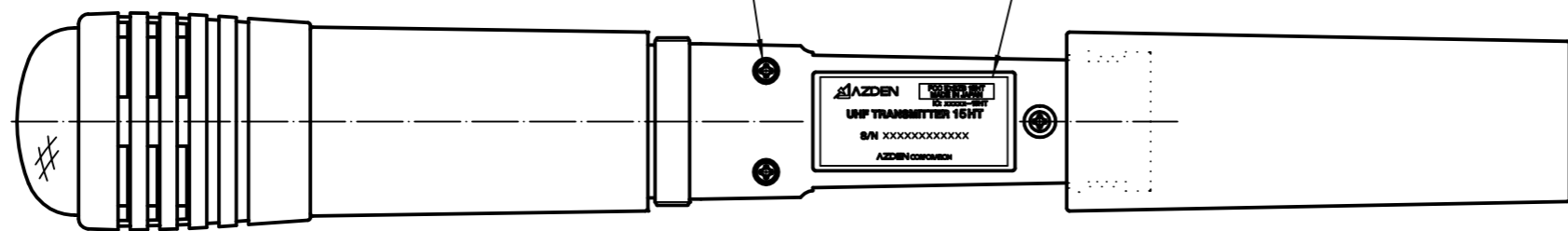

No.	DISCRIPTION	PART NUMBER	Q'TY	MATERIAL	FINISH
1	UPPER CASE	060-25062-04	1	ABS	PAINT
2	UNDER CASE	060-24755-02	1	ABS	PAINT
3	HEAD RING	060-48051-02	1	ABS	PAINT
4	COVER	060-48047-02	1	ABS	PAINT
5	NET	060-48052-01	1	Feメッシュ	PAINT
6	HOLDER	060-34282-01	1	ABS	
7	FILTER	060-42952-01	1	PMMA	
8	SW-KNOB	060-45168-01	1	ABS	
9	BASE-518	060-35010-04	1	ABS	SILK-P
10	HOLDER(DRIV)	060-35004-01	1	ABS	
11	DRIVER	060-47910-01	1	POM	
12	M2X6 PAN SCREW	097-40079F05	3	SWR	MFZN2-B(三価)
13	※ FCC LABEL	060-49234-01	1		
14	CUSHION	060-46568-10	1		
15	※SEAL	060-49208C01	1		
16	※LABEL (GR/CH)	060-49235C01	1		

シリアルNo.の表わし方

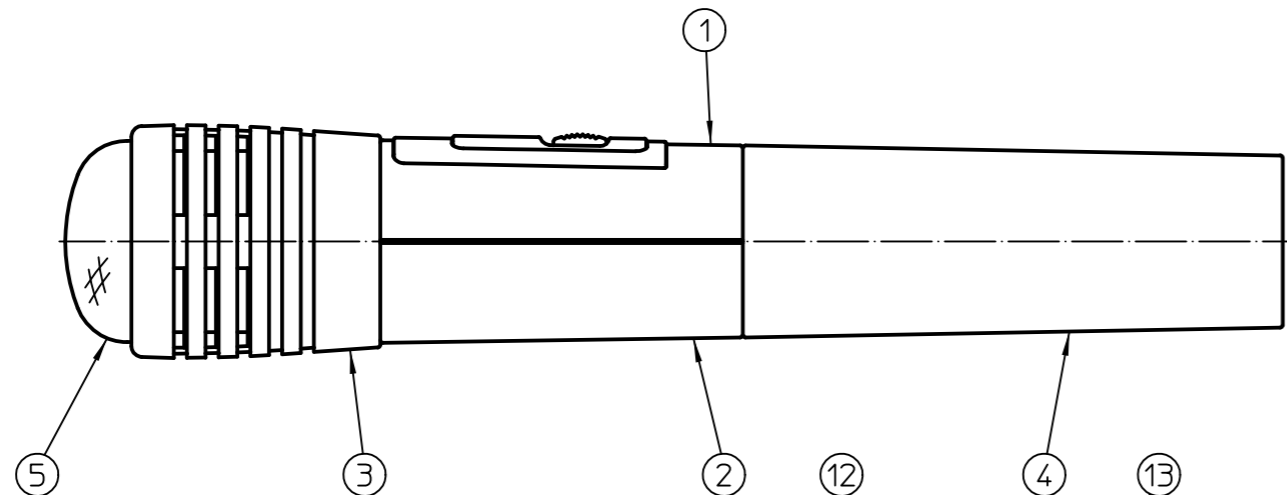
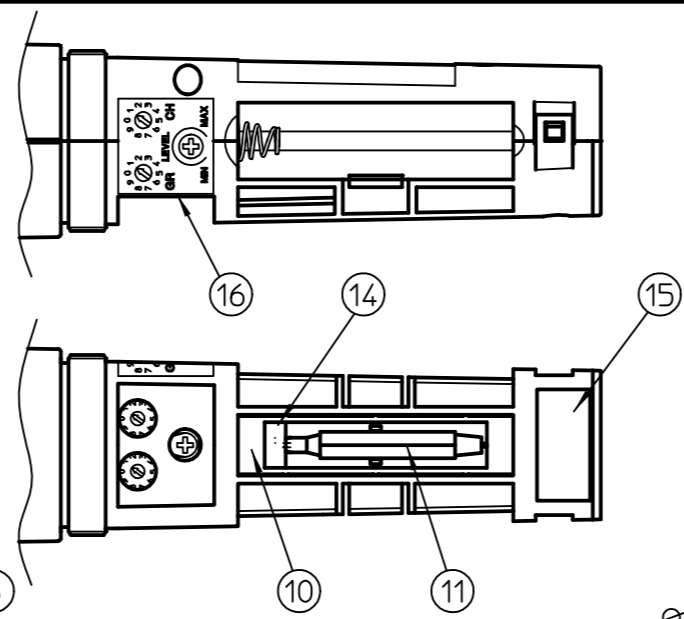
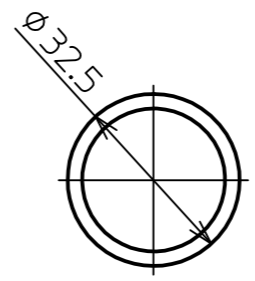
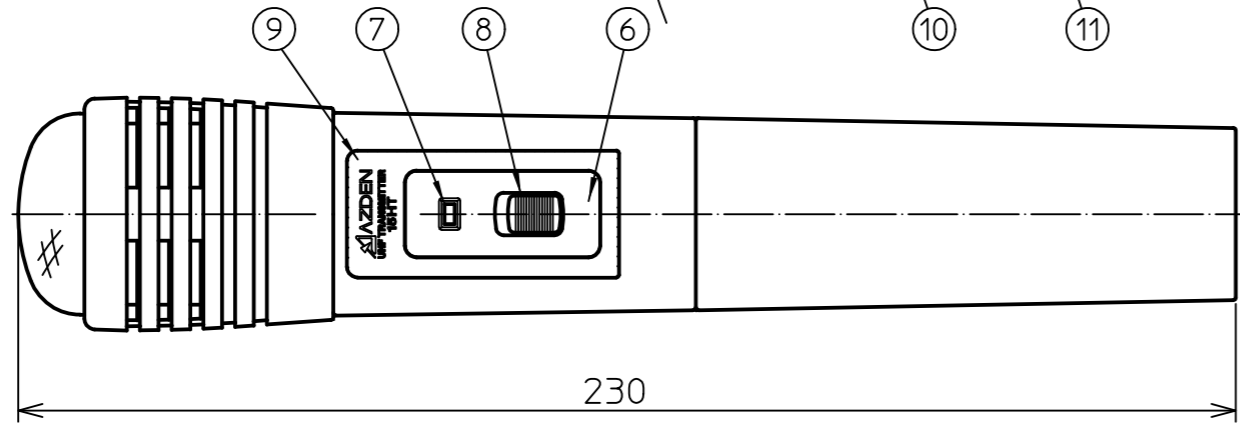
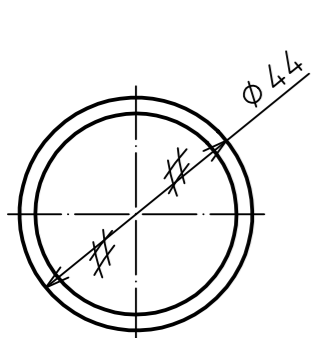
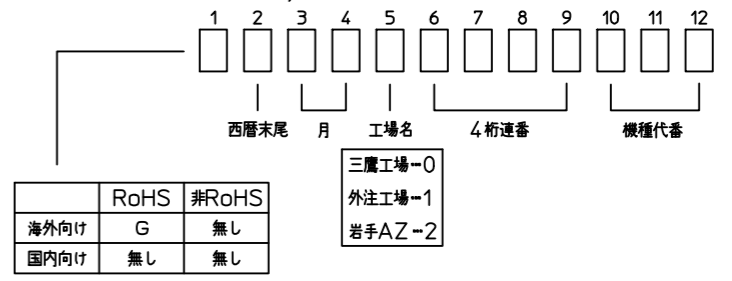

例) 本仕様  
G80920001-03

DRAWN	CHECKED	CHECKED	APPROVED	SCALE	ANGLE
F.木村	永井			1/F	3rd
080711	0807xx				UNIT mm

SYMBOL	REVISION RECORD	DATE	BY
MATERIAL	 AZDEN CORPORATION アズデン 株式会社		
FINISH	TITLE 外形図 APPEARANCE		
USED ON	DRAWING NO		
033-518-03	060-35174		