

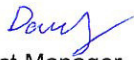

| | | | | |
|--|--|---|-----------------------------|---|
| Prüfbericht-Nr.: <i>Test Report No.:</i> | 10043451 001 | Auftrags-Nr.: <i>Order No.:</i> | 114009544 | Seite 1 von 48 <i>Page 1 of 48</i> |
| Kunden-Referenz-Nr.: <i>Client Reference No.:</i> | N/A | Auftragsdatum: <i>Order date:</i> | May 7, 2013 | |
| Auftraggeber: <i>Client:</i> | Trans Electric Co., Ltd., 771, Sec. 2, Chungsan Road, Huatang, Changhua, Taiwan | | | |
| Prüfgegenstand: <i>Test item:</i> | Bluetooth Music Receiver | | | |
| Bezeichnung / Typ-Nr.: <i>Identification / Type No.:</i> | BTR-1000, BTR-1002, BTR-1000N, BTR-1002N | | | |
| Auftrags-Inhalt: <i>Order content:</i> | FCC Part 15C and RSS-210 Test report | | | |
| Prüfgrundlage: <i>Test specification:</i> | FCC 47CFR Part 15: Subpart C Section 15.247 RSS-210 (12-2010) A8 | | | |
| Wareneingangsdatum: <i>Date of receipt:</i> | 8/30/2013 | | | |
| Prüfmuster-Nr.: <i>Test sample No.:</i> | 800027234 | | | |
| | 800030202 | | | |
| Prüfzeitraum: <i>Testing period:</i> | 4-Sep-2013 - 9-Sep-2013 | | | |
| Ort der Prüfung: <i>Place of testing:</i> | EMC Laboratory Taipei | | | |
| Prüflaboratorium: <i>Testing laboratory:</i> | TUV Rheinland Taiwan Ltd. | | | |
| Prüfergebnis*: <i>Test result*:</i> | Pass | | | |
| geprüft von / tested by: | | kontrolliert von / reviewed by: | | |
| 2013-10-22 Danny S. C. Sung/Project Manager | | 2013-10-22 Rene Charton/Senior Project Manager | | |
| Datum <i>Date</i> | Name / Stellung <i>Name / Position</i> | Unterschrift <i>Signature</i> | Datum <i>Date</i> | Name / Stellung <i>Name / Position</i> |
| | |  | |  |
| Sonstiges / Other: | | | | |
| Zustand des Prüfgegenstandes bei Anlieferung: <i>Condition of the test item at delivery:</i> | | Prüfmuster vollständig und unbeschädigt <i>Test item complete and undamaged</i> | | |
| * Legende: 1 = sehr gut 2 = gut 3 = befriedigend 4 = ausreichend 5 = mangelhaft P(ass) = entspricht o.g. Prüfgrundlage(n) F(ail) = entspricht nicht o.g. Prüfgrundlage(n) N/A = nicht anwendbar N/T = nicht getestet | | | | |
| Legend: 1 = very good 2 = good 3 = satisfactory 4 = sufficient 5 = poor P(ass) = passed a.m. test specification(s) F(ail) = failed a.m. test specification(s) N/A = not applicable N/T = not tested | | | | |
| Dieser Prüfbericht bezieht sich nur auf das o.g. Prüfmuster und darf ohne Genehmigung der Prüfstelle nicht auszugsweise vervielfältigt werden. Dieser Bericht berechtigt nicht zur Verwendung eines Prüfzeichens. <i>This test report only relates to the a. m. test sample. Without permission of the test center this test report is not permitted to be duplicated in extracts. This test report does not entitle to carry any test mark.</i> | | | | |

v04

TEST SUMMARY

5.1.1 ANTENNA REQUIREMENT*RESULT: Passed***5.1.2 PEAK OUTPUT POWER***RESULT: Passed***5.1.3 20DB BANDWIDTH***RESULT: Passed***5.1.4 99% BANDWIDTH***RESULT: Passed***5.1.5 CONDUCTED SPURIOUS EMISSIONS AND FREQUENCY BAND EDGE MEASURED IN 100KHz BANDWIDTH***RESULT: Passed***5.1.6 SPURIOUS EMISSION***RESULT: Passed***5.1.7 FREQUENCY SEPARATION***RESULT: Passed***5.1.8 NUMBER OF HOPPING FREQUENCY***RESULT: Passed***5.1.9 TIME OF OCCUPANCY***RESULT: Passed***5.2.1 MAINS CONDUCTED EMISSIONS***RESULT: Passed***6.1.1 ELECTROMAGNETIC FIELDS***RESULT: Passed*

Contents

| | | |
|--------------|---|-----------|
| 1. | GENERAL REMARKS | 5 |
| 1.1 | COMPLEMENTARY MATERIALS..... | 5 |
| 2. | TEST SITES | 6 |
| 2.1 | TEST FACILITIES | 6 |
| 2.2 | LIST OF TEST AND MEASUREMENT INSTRUMENTS..... | 6 |
| 2.3 | TRACEABILITY | 7 |
| 2.4 | CALIBRATION | 7 |
| 2.5 | MEASUREMENT UNCERTAINTY | 7 |
| 3. | GENERAL PRODUCT INFORMATION..... | 8 |
| 3.1 | PRODUCT FUNCTION AND INTENDED USE | 8 |
| 3.2 | RATINGS AND SYSTEM DETAILS..... | 8 |
| 3.3 | INDEPENDENT OPERATION MODES..... | 9 |
| 3.4 | NOISE GENERATING AND NOISE SUPPRESSING PARTS | 10 |
| 3.5 | SUBMITTED DOCUMENTS..... | 10 |
| 4. | TEST SET-UP AND OPERATION MODES..... | 11 |
| 4.1 | PRINCIPLE OF CONFIGURATION SELECTION | 11 |
| 4.2 | TEST OPERATION AND TEST SOFTWARE..... | 11 |
| 4.3 | SPECIAL ACCESSORIES AND AUXILIARY EQUIPMENT | 11 |
| 4.4 | COUNTERMEASURES TO ACHIEVE EMC COMPLIANCE..... | 12 |
| 4.5 | TEST SETUP DIAGRAM | 12 |
| 5. | TEST RESULTS | 14 |
| 5.1 | TRANSMITTER REQUIREMENT & TEST SUITES | 14 |
| <i>5.1.1</i> | <i>Antenna Requirement</i> | <i>14</i> |
| <i>5.1.2</i> | <i>Peak Output Power</i> | <i>15</i> |
| <i>5.1.3</i> | <i>20dB Bandwidth</i> | <i>19</i> |
| <i>5.1.4</i> | <i>99% Bandwidth</i> | <i>24</i> |
| <i>5.1.5</i> | <i>Conducted spurious emissions and Frequency Band Edge measured in 100kHz Bandwidth.....</i> | <i>28</i> |
| <i>5.1.6</i> | <i>Spurious Emission</i> | <i>34</i> |
| <i>5.1.7</i> | <i>Frequency Separation.....</i> | <i>35</i> |
| <i>5.1.8</i> | <i>Number of hopping frequency.....</i> | <i>37</i> |
| <i>5.1.9</i> | <i>Time of Occupancy</i> | <i>39</i> |
| 5.2 | MAINS EMISSIONS..... | 42 |
| <i>5.2.1</i> | <i>Mains Conducted Emissions.....</i> | <i>42</i> |
| 6. | SAFETY HUMAN EXPOSURE | 43 |

| | | |
|------------|--|-----------|
| 6.1 | RADIO FREQUENCY EXPOSURE COMPLIANCE | 43 |
| 6.1.1 | <i>Electromagnetic Fields.....</i> | <i>43</i> |
| 7. | PHOTOGRAPHS OF THE TEST SET-UP..... | 44 |
| 8. | LIST OF TABLES | 48 |
| 9. | LIST OF PHOTOGRAPHS..... | 48 |

1. General Remarks

1.1 Complementary Materials

All attachments are integral parts of this test report. This applies especially to the following appendix:

Appendix PI: Photo Documentation internal view
(File Name: 10043451APPENDIX PI)

Appendix PE: Photo Documentation external view
(File Name: 10043451APPENDIX PE)

Appendix D: Test Result of Radiated Emissions
(File Name: 10043451APPENDIX D)

Test Specifications

The following standards were applied (in bold: product standards, otherwise: basic standards).

Table 1: Applied Standard and Test Levels

| Radio |
|---|
| FCC CFR47 Part 15: Subpart C Section 15.247 ANSI C63.4:2009, Public Notice DA 00-705 |

2. Test Sites

2.1 Test Facilities

TUV Rheinland Taiwan Ltd.

11F. No.758, Sec. 4, Bade Rd., Songshan Dist.
 Taipei City 105
 Taiwan (R.O.C.)
 FCC Registration No.: 365730

2.2 List of Test and Measurement Instruments

Table 2: List of Test and Measurement Equipment

| Kind of Equipment | Manufacturer | Type | S/N | Calibrated until |
|-------------------------------|--------------|-----------|------------------------|------------------|
| EMI Test Receiver | R&S | ESCI 7 | 1166.5950K07-100797-Pt | 20-Dec-13 |
| Bilog Antenna | TESEQ | CBL6111D | 29802 | 29-Jun-14 |
| Pre-Amplifier | HP | 8447F | 2805A03335 | 2-Sep-14 |
| Spectrum Analyzer | R&S | FSV 40 | 100921 | 13-Dec-13 |
| Horn Antenna | ETS-Lindgren | 3117 | 00138160 | 10-Jan-15 |
| Horn Antenna (18GHz~40GHz) | COM-POWER | AH840 | 101031 | 2-Nov-13 |
| Preamplifier (30MHz -1GHz) | HP | 8447F | 2805A03335 | 2-Sep-14 |
| Preamplifier (18 GHz -40 GHz) | COMPOWER | PAM-840 | 461257 | 2-Sep-14 |
| Loop Antenna | Schwarzbeck | FMZB 1513 | 1513-076 | 28-Sep-14 |
| EMI Test Receiver | R&S | ESCI | 101094 | 29-Aug-14 |
| LISN (1 phase) | R&S | ENV216 | 101243 | 5-Jun-14 |
| LISN | Rolf Heine | NNB-2/16Z | 99080 | 30-Aug-14 |

2.3 Traceability

All measurement equipment calibrations are traceable to NML(Taiwan)/NIST(USA) or where calibration is performed outside Taiwan, to equivalent nationally recognized standards organizations.

2.4 Calibration

Equipment requiring calibration is calibrated periodically by the manufacturer or according to manufacturer's specifications. Additionally all equipment is verified for proper performance on a regular basis using in house standards or comparisons.

2.5 Measurement Uncertainty

The estimated combined standard uncertainty for radiated emissions and conducted emissions measurements are ± 3 dB.

Table 3: Emission Measurement Uncertainty

| Parameter | Uncertainty |
|--|------------------------|
| Radio Frequency | $\pm 1 \times 10^{-7}$ |
| RF power, conducted | ± 1 dB |
| Adjacent channel power | ± 3 dB |
| Radiated emission of transmitter, valid up to 26 GHz | ± 6 dB |
| Radiated emission of receiver, valid up to 26 GHz | ± 6 dB |
| Temperature | ± 2 °C |
| Humidity | ± 10 % |

3. General Product Information

3.1 Product Function and Intended Use

The EUT is a device which provides an Audio signal which is received via Bluetooth from a Wireless Mobile Device. The models shown on the cover page differ in that the models BTR-1002/BTR-1002N have an additional connect switch which is part of the digital device portion of the equipment. The two models BTR-1000N/BTR-1002N additionally have a passive NFC tag glued to the inside of the upper enclosure part. The test report shows the worst case data, for the model BTR-1000.

For details refer to the User Guide, Data Sheet and Circuit Diagram.

3.2 System Details and Ratings

Table 4: Basic Information of EUT

| Item | EUT information |
|-------------------|--|
| Kind of Equipment | Bluetooth Music Receiver |
| Type Designation | BTR-1000, BTR-1002, BTR-1000N, BTR-1002N |
| | |
| FCC ID | BY4BTR1000 Canada ID IC:3780A-BTR1000 |
| | |

Table 5: Technical Specification of EUT

| Technical Specification | Value |
|-------------------------|----------------------------|
| Operating Frequency | 2402 MHz ~ 2480 MHz |
| Channel Spacing | 1 MHz |
| Channel number | 79 |
| Operation Voltage | 5 V |
| Modulation | GFSK, $\pi/4$ QPSK, 8 DPSK |
| Antenna gain | 0.5 dBi |

Table 6: Frequency hopping information

| Technical Specification | Description |
|--------------------------|--|
| Hopping Range | Hereby we declare that the maximum frequency of this device is: 2402-2480MHz. This is according the Bluetooth Core Specification V2.1+EDR for devices which will be operated in the USA. This was checked during the Bluetooth Qualification tests (Test Case: TRM/CA/04). |
| Hopping Sequence | Example of a 79 hopping sequence in data mode: 33,04,21,44,23,42,53,46,55,48,40,59,72,29,76,31,08,73,07,75,09,45,60,39,58,13,47,11,77,52,35,50,65,54,67,56,69,62,71,64, 7,25,27,66,57,70,74,61,78,63,10,41,05,43,15,44,64,68,02,70,06,01,51,03,55,05,03,66,53,49,36,47, |
| Receiver input bandwidth | <p>The input bandwidth of the receiver is 1MHz. In every connection one Bluetooth device is the master and the other one is the slave. The master determines the hopping sequence. The slave follows this sequence. Both devices shift between RX and TX time slot according to the clock of the master.</p> <p>Additionally the type of connection is set up at the beginning of the connection. The master adapts its hopping frequency and its TX/RX timing according to the packet type of the connection. Also the slave of the connection will use these settings.</p> <p>Repeating of a packer has no influence on the hopping sequence. The hopping sequence generated by the master of the connection will be followed in any case.</p> <p>That means a repeated packet will not be send on the same frequency, it is send on the next frequency of the hopping sequence.</p> |

3.3 Independent Operation Modes

The basic operation modes are:

- A. Transmitting
 - 1. Low channel
 - 2. Middle channel
 - 3. High channel
- B. Receiving
- C. Standby
- D. Off

3.4 Noise Generating and Noise Suppressing Parts

Refer to the Circuit Diagram.

3.5 Submitted Documents

- Bill of Material
- PCB Layout
- Photo Document
- Technical Description
- Circuit Diagram
- Instruction Manual
- Rating Label

4. Test Set-up and Operation Modes

4.1 Principle of Configuration Selection

The equipment under test (EUT) was configured to measure its maximum power level. The test modes were adapted accordingly in reference to the instructions for use.

4.2 Test Operation and Test Software

Test operation refers to test setup in chapter 4. All testing were performed according to the procedures in ANSI C63.10: 2009 and DA 00-705 of March 30, 2000.

The samples were used as follows:

Conducted: **800030202**

Radiation: **800027234**

Full test was applied on all test modes, but only worst case was shown.

4.3 Special Accessories and Auxiliary Equipment

The product has been tested together with the following additional accessories:

| Kind of Equipment | Manufacturer | Model Name | S/N |
|-------------------|--------------|----------------------|-------------------------------|
| Laptop | MSI | MSI4532 (CX420MX) | CX420 MX-233TWK 1008000096 |

4.4 Countermeasures to achieve EMC Compliance

The test sample which has been tested contained the noise suppression parts as described in the Constructional Data Form or the Technical Construction File. No additional measures were employed to achieve compliance.

4.5 Test Setup Diagram

Diagram of Measurement Configuration for Radiation Test

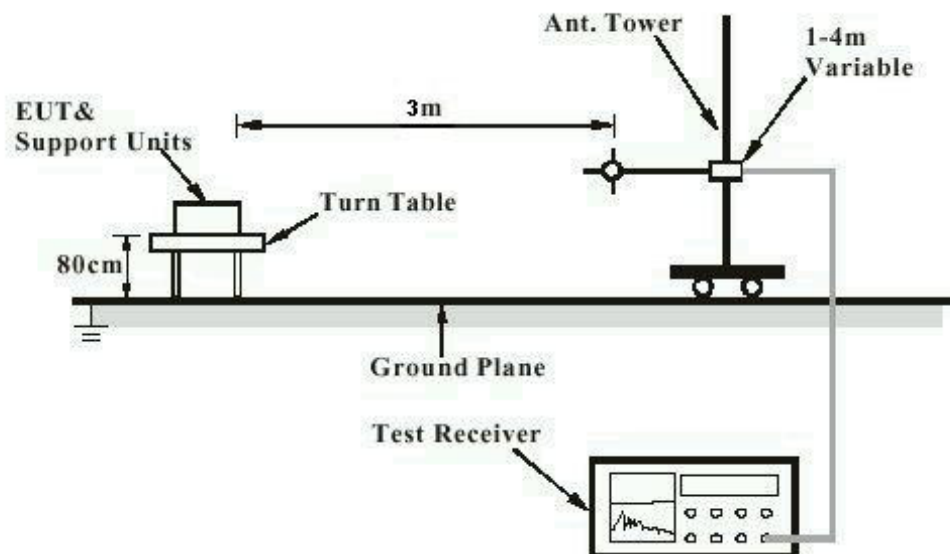

Diagram of Measurement Equipment Configuration for Mains Conduction Measurement

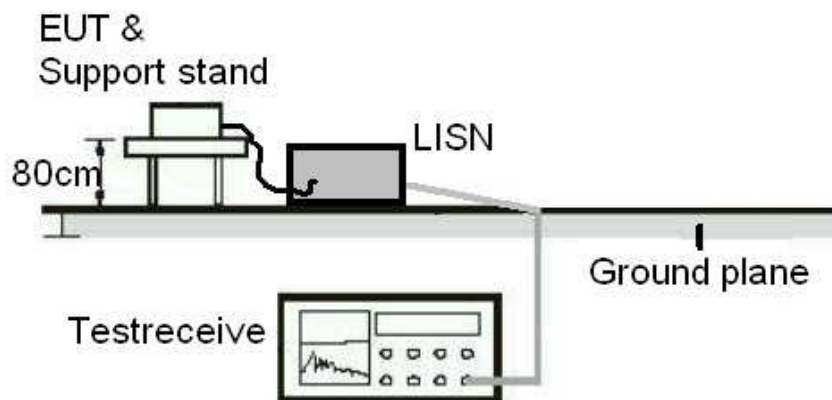
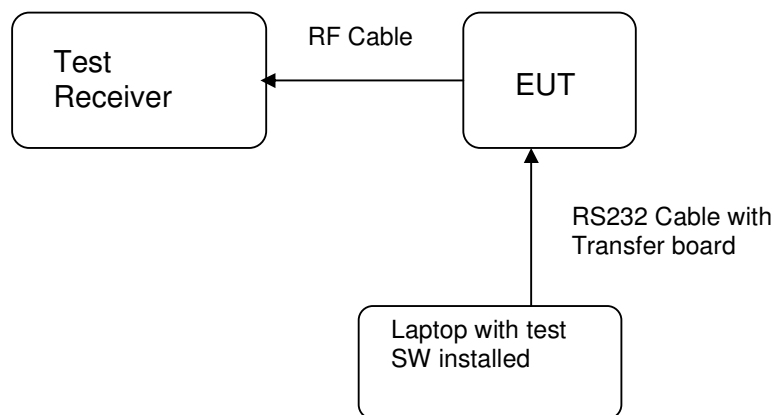

Diagram of Measurement Equipment Configuration for Conducted Transmitter Measurement



5. Test Results

5.1 Transmitter Requirement & Test Suites

5.1.1 Antenna Requirement

RESULT: **Passed**

Test standard : FCC Part 15.247(b)(4), Part 15.203 and RSS-Gen 7.1.4
Limit : the use of antennas with directional gains that do not exceed 6 dBi

According to the manufacturer declaration, the EUT has an antenna with a directional gain of 0.5 dBi. The antenna is a Chip Antenna soldered to the PCB with no possibility of replacement with a non-approved antenna by the end-user. Therefore, the EUT is considered to comply with this provision.

.

Refer to EUT photo for details.

5.1.2 Peak Output Power

RESULT:
Passed

Test standard : FCC Part 15.247(b)(1), RSS-210 A8.4(2)
 Basic standard : DA 00-705 of March 30, 2000
 Kind of test site : Shielded room

Test setup

Test Channel : Low/ Middle/ High
 Operation Mode : A

Ambient temperature : 22-26 °C
 Relative humidity : 50-65 %
 Atmospheric pressure : 100-103 kPa

Table 7: Test result of Peak Output Power, GFSK modulation

| Channel | Channel Frequency | Peak Output Power | | Limit |
|----------------|-------------------|-------------------|---------|-------|
| | (MHz) | (dBm) | (W) | (W) |
| Low Channel | 2402 | -2.21 | 0.00060 | 0.125 |
| Middle Channel | 2441 | -2.54 | 0.00056 | 0.125 |
| High Channel | 2480 | -2.97 | 0.00050 | 0.125 |

Table 8: Test result of Peak Output Power, 8DPSK modulation

| Channel | Channel Frequency | Peak Output Power | | Limit |
|----------------|-------------------|-------------------|---------|-------|
| | (MHz) | (dBm) | (W) | (W) |
| Low Channel | 2402 | 0.20 | 0.00105 | 0.125 |
| Middle Channel | 2441 | -0.10 | 0.00098 | 0.125 |
| High Channel | 2480 | -0.41 | 0.00091 | 0.125 |

Pmax: 1.0471 mW

Test Plot of Peak Output Power, GFSK modulation

Low Channel

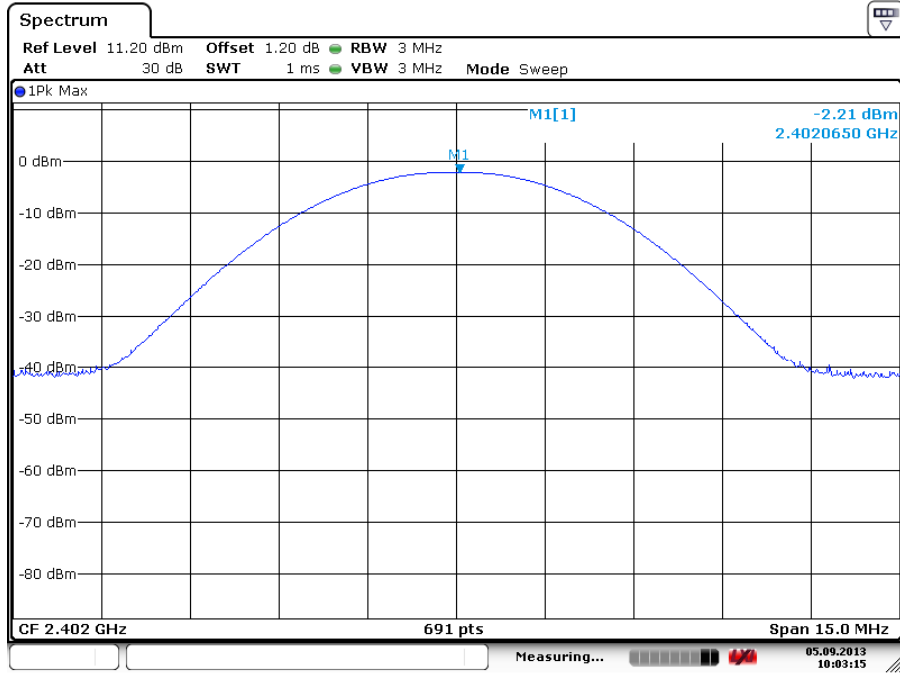

Date: 5.SEP.2013 10:03:16

Middle Channel

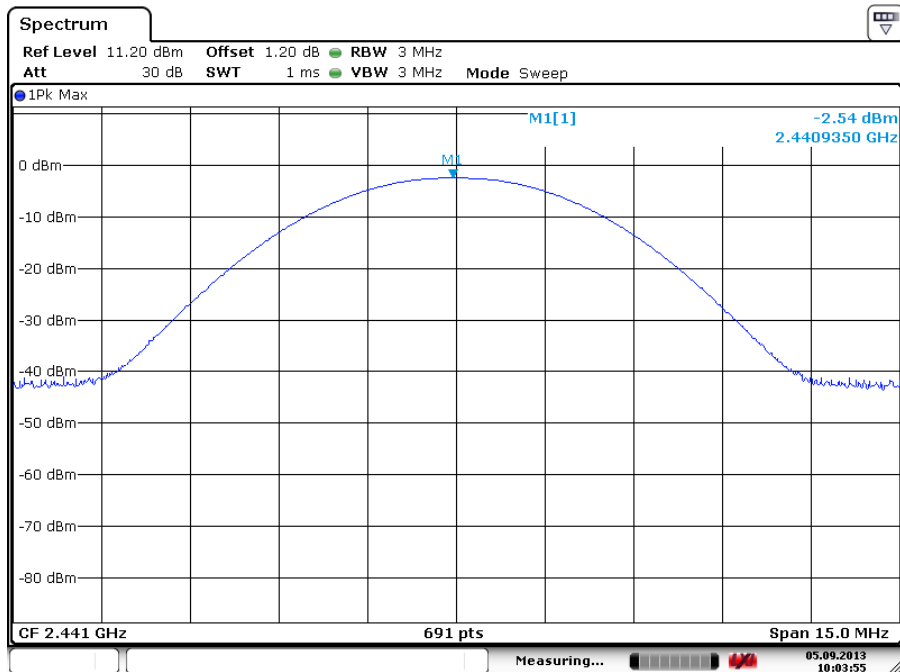

Date: 5.SEP.2013 10:03:55

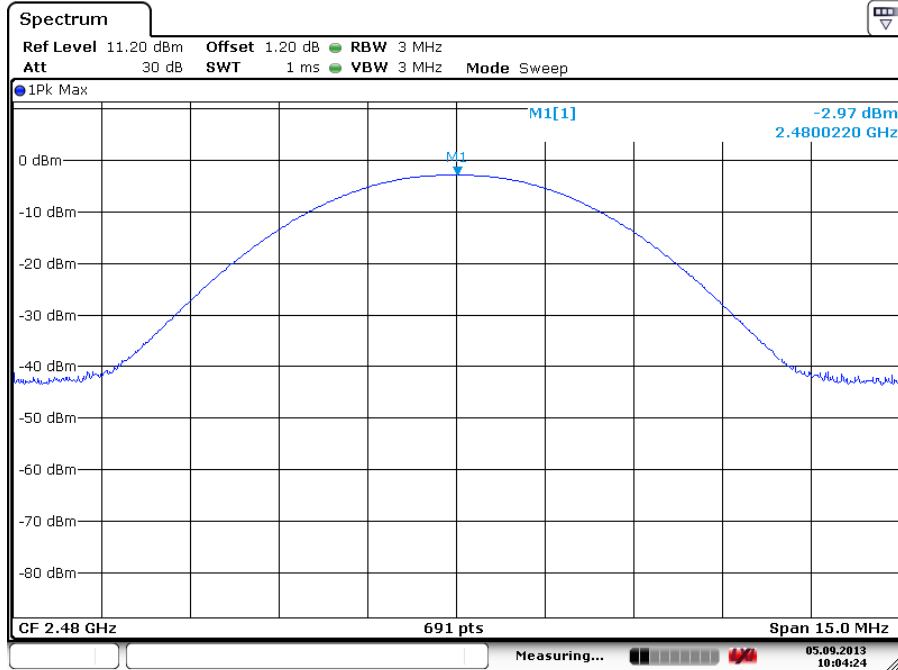
High Channel

Date: 5.SEP.2013 10:04:25

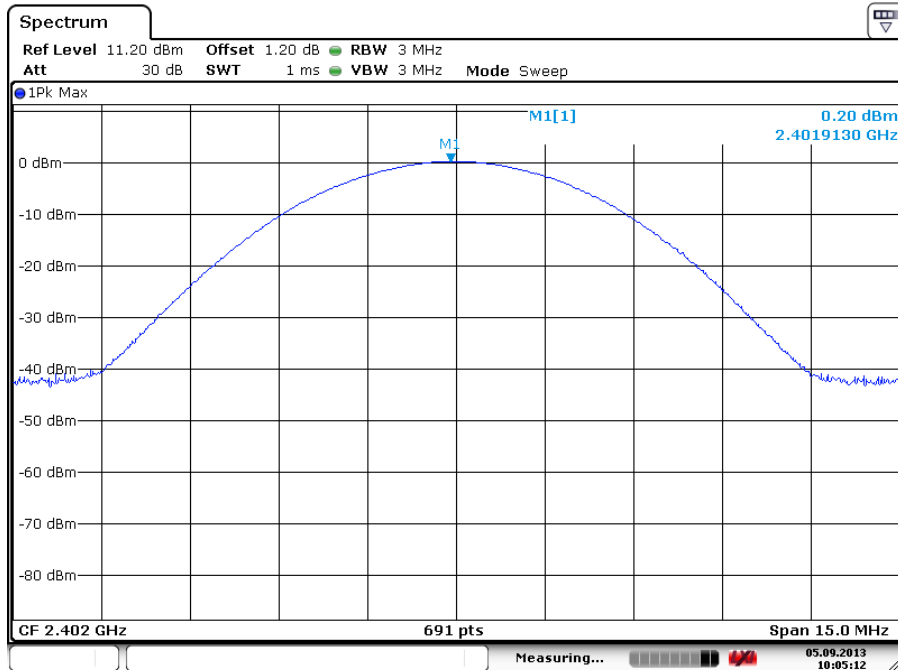
Test Plot of Peak Output Power, 8DPSK modulation
Low Channel

Date: 5.SEP.2013 10:05:12

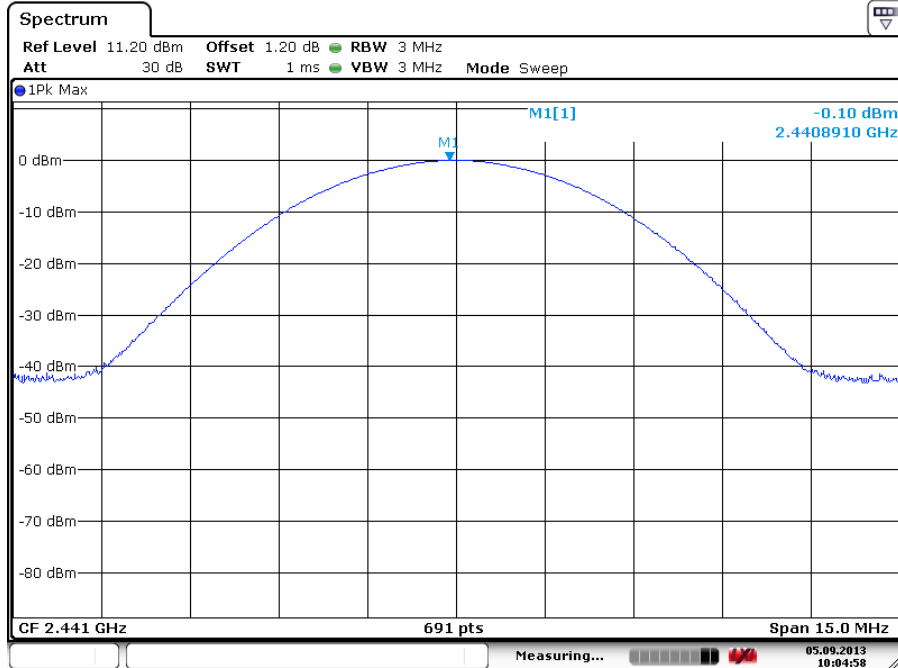
Middle Channel

Date: 5.SEP.2013 10:04:58

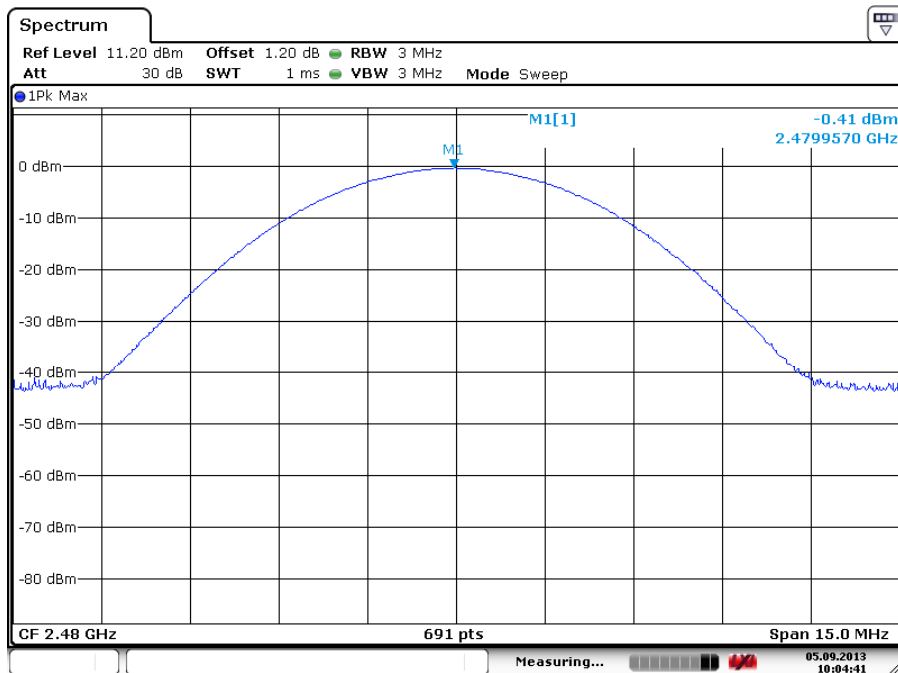
High Channel

Date: 5.SEP.2013 10:04:41

5.1.3 20dB Bandwidth

RESULT:
Passed

Test standard : FCC Part 15.247(a)(1), RSS-210 A8.1(a)
 Basic standard : DA 00-705 of March 30, 2000
 Kind of test site : Shielded room

Test setup

Test Channel : Low/ Middle/ High
 Operation Mode : A

Ambient temperature : 22-26°C
 Relative humidity : 50-65%
 Atmospheric pressure : 100-103 kPa

Table 9: Test result of 20dB Bandwidth, GFSK modulation

| Channel | Channel Frequency (MHz) | 20dB Bandwidth (kHz) | Limit (MHz) | Result |
|--------------|-------------------------|----------------------|-------------|--------|
| Low Channel | 2402 | 998.6 | 1.5 | Pass |
| Mid Channel | 2441 | 968.2 | 1.5 | Pass |
| High Channel | 2480 | 994.2 | 1.5 | Pass |

Note: Limit is for Channel Separation of 1 MHz and a power limit of 125 mW.

Table 10: Test result of 20dB Bandwidth, 8DPSK modulation

| Channel | Channel Frequency (MHz) | 20dB Bandwidth (kHz) | Limit (MHz) | Result |
|--------------|-------------------------|----------------------|-------------|--------|
| Low Channel | 2402 | 1324.2 | 1.5 | Pass |
| Mid Channel | 2441 | 1324.2 | 1.5 | Pass |
| High Channel | 2480 | 1289.4 | 1.5 | Pass |

Note: Limit is for Channel Separation of 1 MHz and a power limit of 125 mW.

Test Plot of 20dB Bandwidth, GFSK modulation

Low Channel

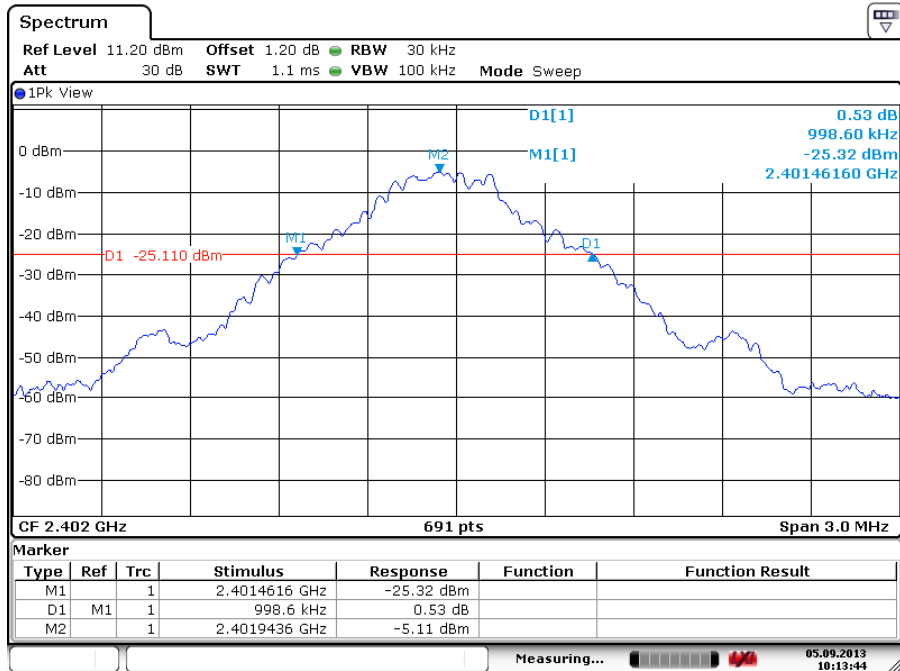

Date: 5.SEP.2013 10:13:44

Middle Channel

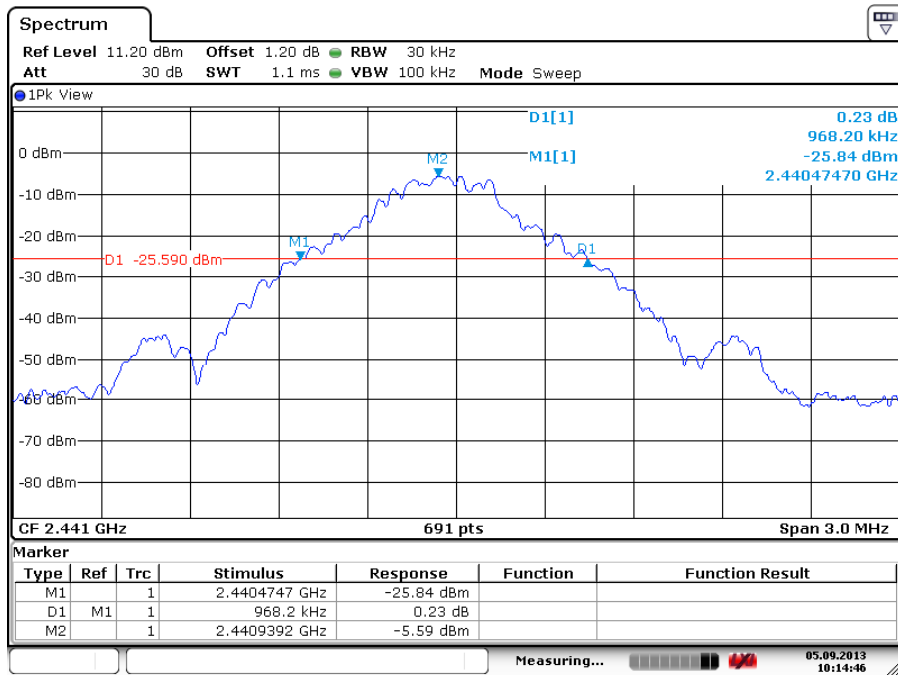

Date: 5.SEP.2013 10:14:46

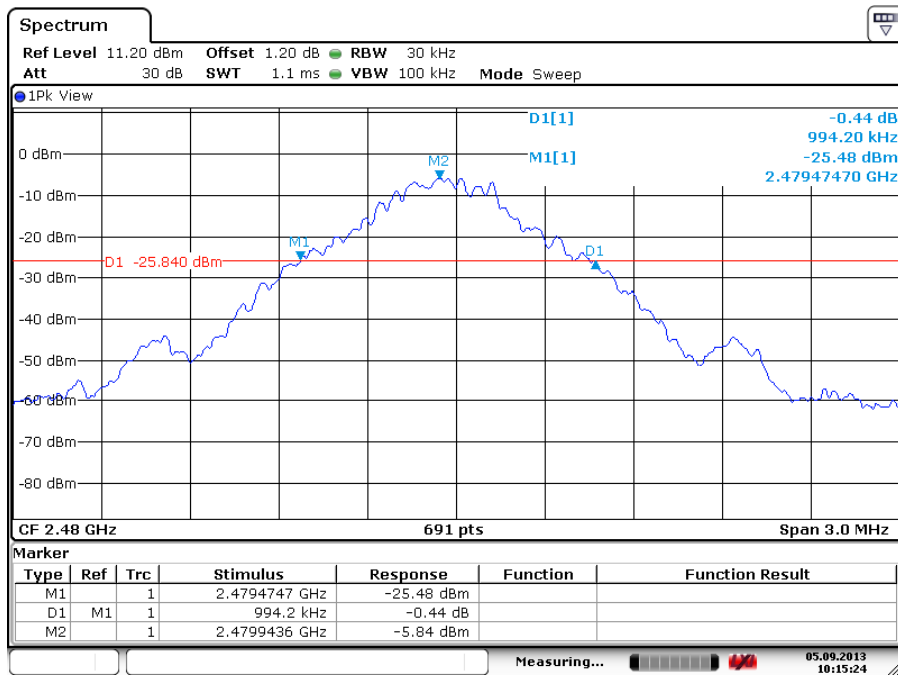
High Channel

Date: 5.SEP.2013 10:15:24

Test Plot of 20dB Bandwidth, 8DPSK modulation
Low Channel

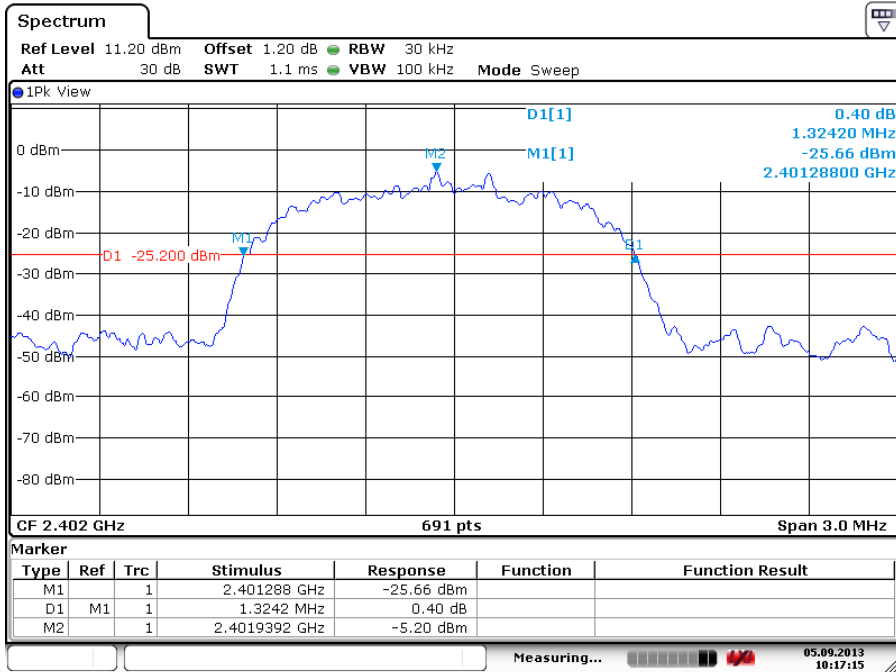

Date: 5.SEP.2013 10:17:15

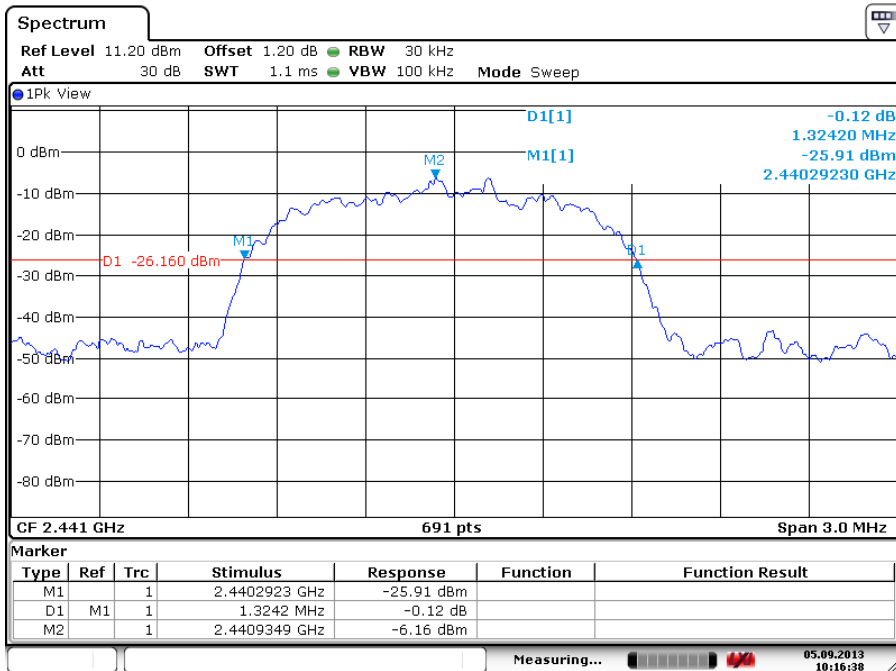
Middle Channel

Date: 5.SEP.2013 10:16:38

High Channel

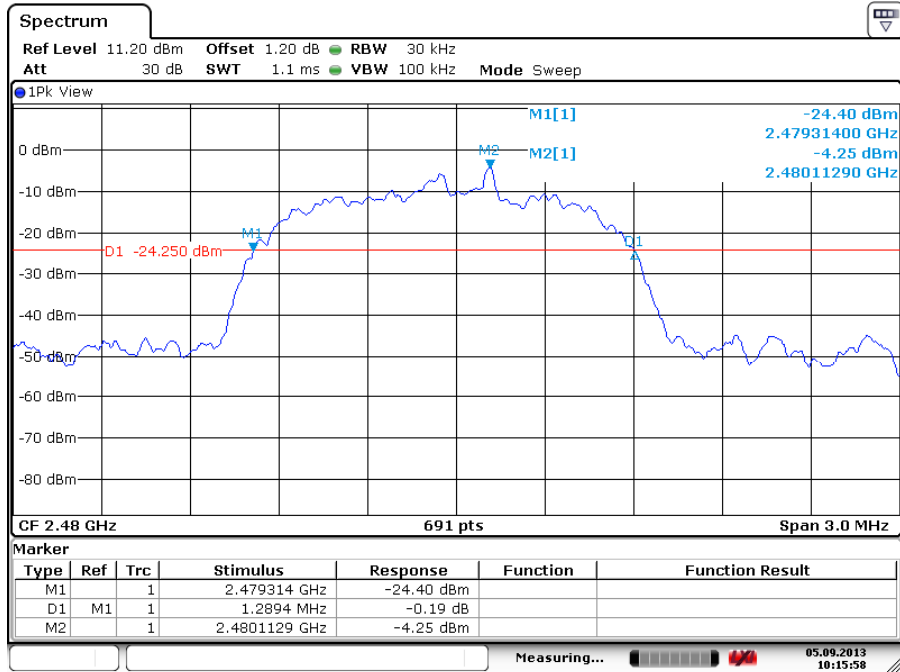

Date: 5.SEP.2013 10:15:58

5.1.4 99% Bandwidth

RESULT:
Passed

Test standard : RSS-Gen (Issue 3) Dec. 2010
 Basic standard : RSS-Gen (Issue 3) Dec. 2010
 Kind of test site : Shielded room

Test setup

Test Channel : Low/ Middle/ High
 Operation Mode : A

 Ambient temperature : 22-26°C
 Relative humidity : 50-65%
 Atmospheric pressure : 100-103 kPa

Table 11: Test result of 99% Bandwidth, GFSK modulation

| Channel | Channel Frequency (MHz) | 99% Bandwidth (kHz) | Limit (MHz) | Result |
|--------------|-------------------------|---------------------|-------------|--------|
| Low Channel | 2402 | 885.6 | / | Pass |
| Mid Channel | 2441 | 903.0 | / | Pass |
| High Channel | 2480 | 894.3 | / | Pass |

Table 12: Test result of 99% Bandwidth, 8DPSK modulation

| Channel | Channel Frequency (MHz) | 99% Bandwidth (kHz) | Limit (MHz) | Result |
|--------------|-------------------------|---------------------|-------------|--------|
| Low Channel | 2402 | 1180.8 | / | Pass |
| Mid Channel | 2441 | 1180.8 | / | Pass |
| High Channel | 2480 | 1176.5 | / | Pass |

Test Plot of 99% Bandwidth, GFSK modulation

Low Channel

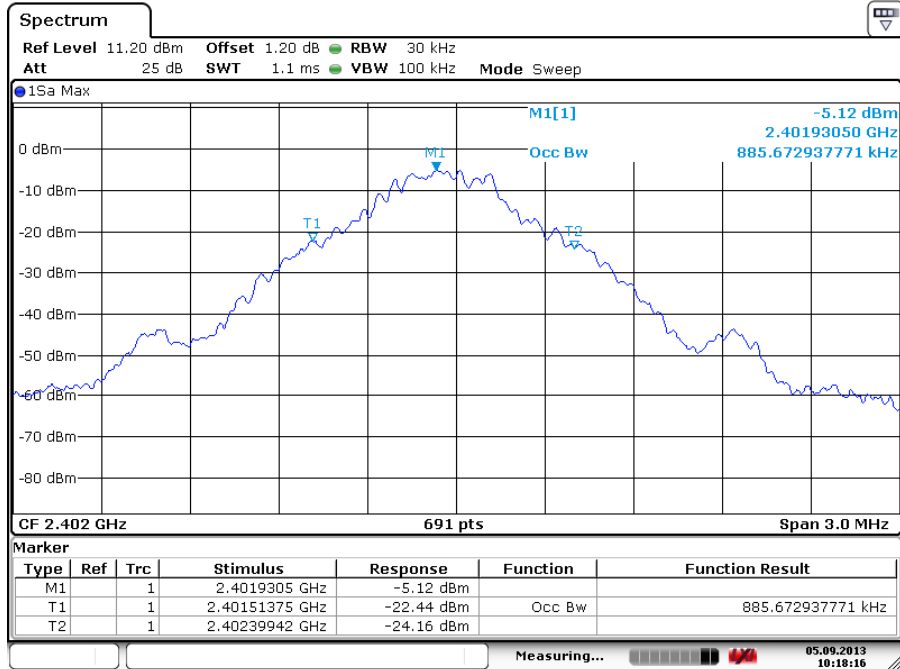

Date: 5.SEP.2013 10:18:16

Middle Channel

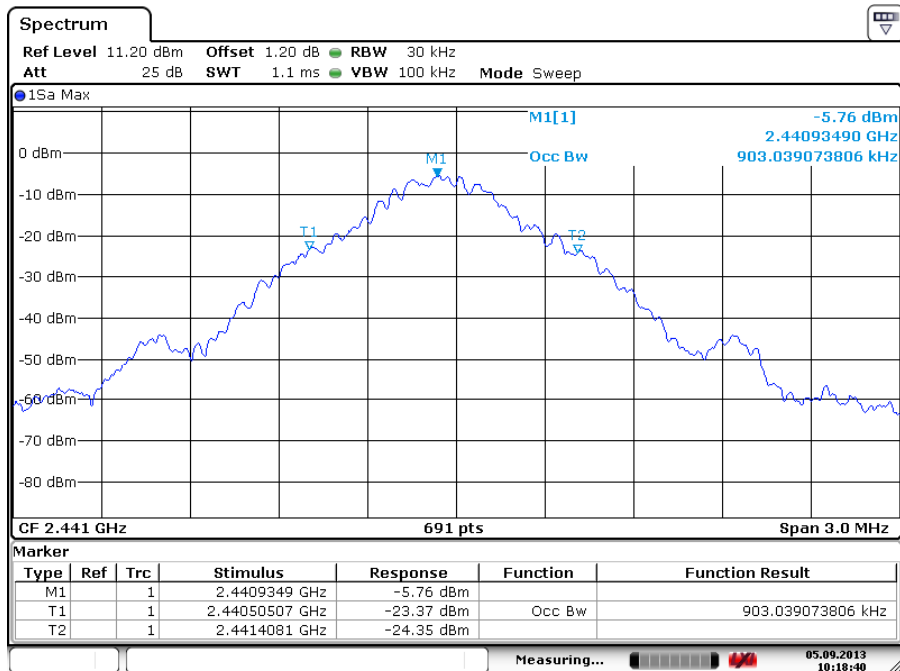

Date: 5.SEP.2013 10:18:40

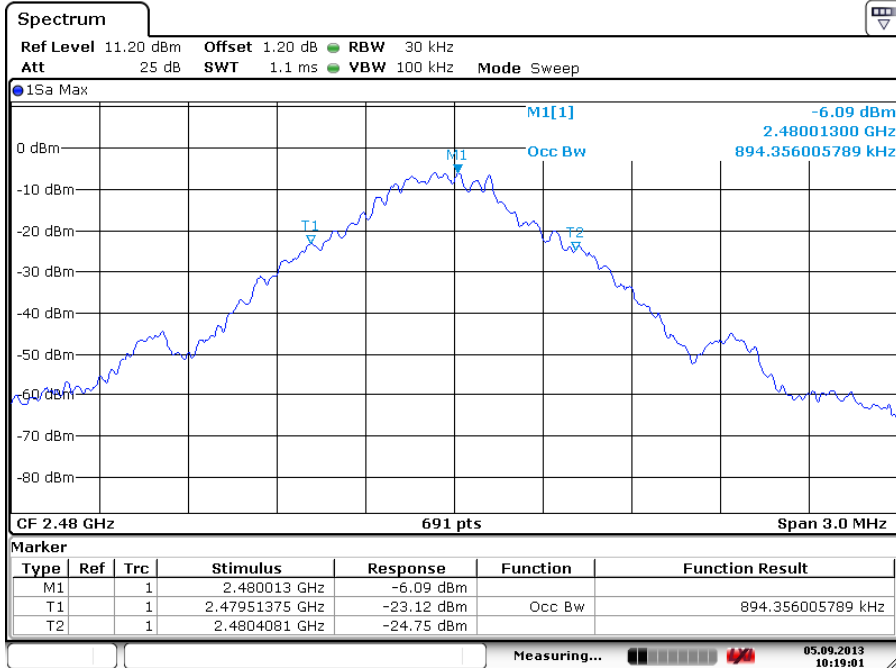
High Channel

Date: 5.SEP.2013 10:19:01

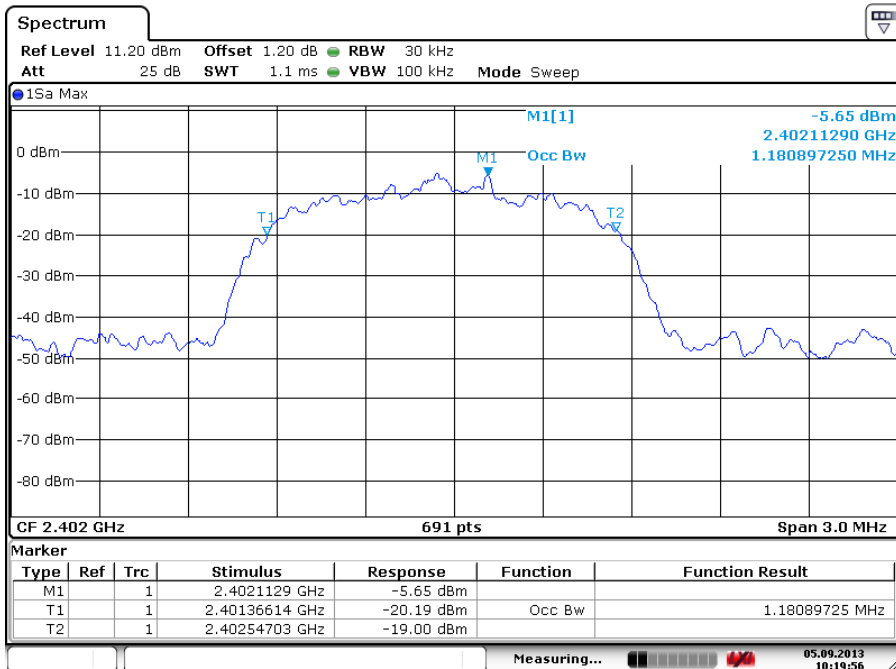
Test Plot of 99% Bandwidth, 8DPSK modulation
Low Channel

Date: 5.SEP.2013 10:19:56

Middle Channel

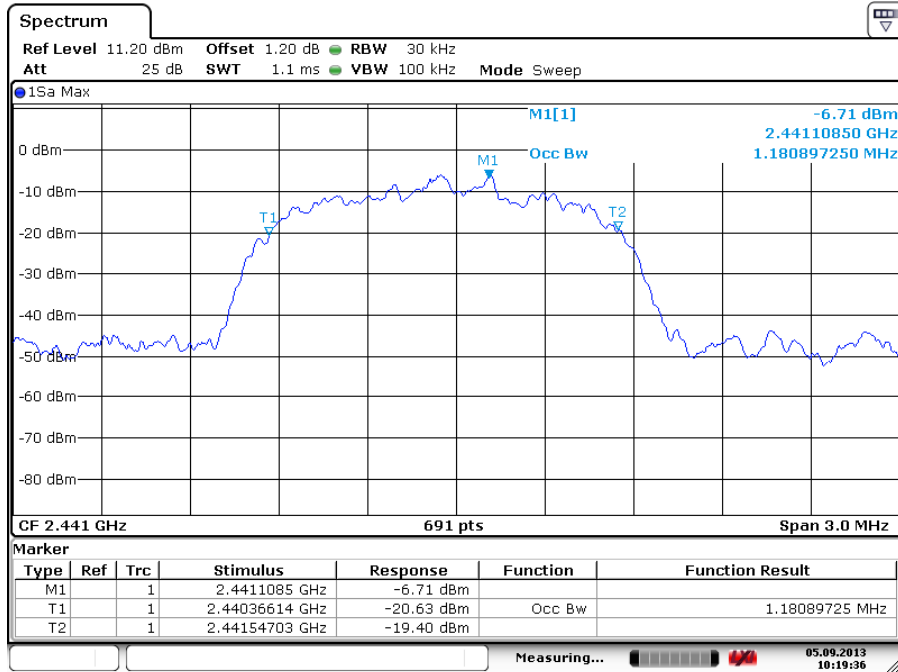

Date: 5.SEP.2013 10:19:36

High Channel

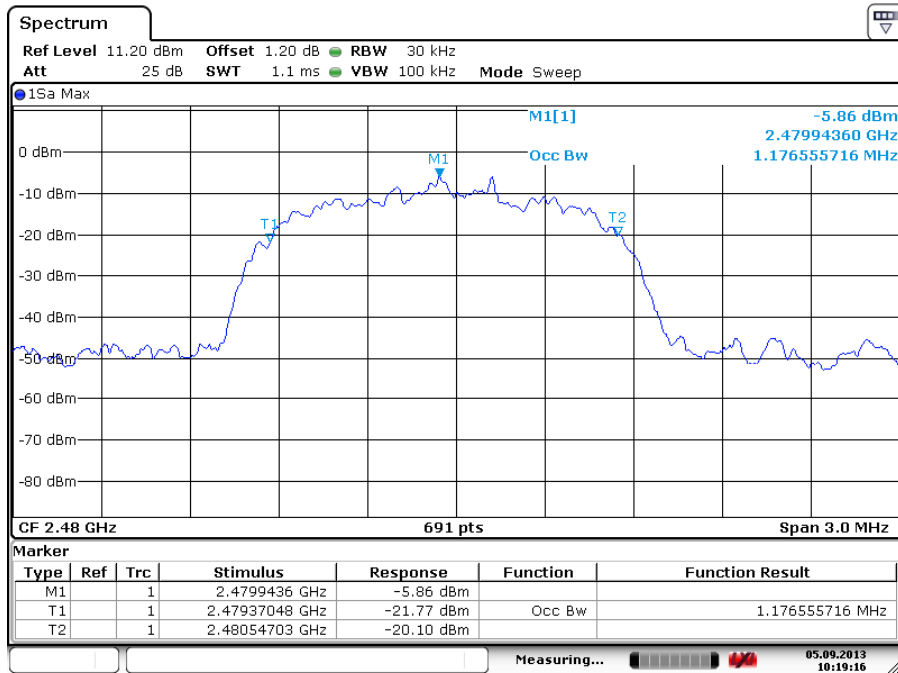

Date: 5.SEP.2013 10:19:16

5.1.5 Conducted spurious emissions and Frequency Band Edge measured in 100kHz Bandwidth

RESULT:**Passed**

| | | |
|-------------------|---|--|
| Test standard | : | FCC part 15.247(d), RSS-210 A8.5 |
| Basic standard | : | DA 00-705 of March 30, 2000 |
| Limit | : | 20dB (below that in the 100kHz bandwidth within the band that contains the highest level of the desired power) |
| Kind of test site | : | Shielded room |

Test setup

| | | |
|----------------------|---|-------------------|
| Test Channel | : | Low/ Middle/ High |
| Operation Mode | : | A |
| Ambient temperature | : | 22-26°C |
| Relative humidity | : | 50-65% |
| Atmospheric pressure | : | 100-103 kPa |

All emissions are more than 20dB below fundamental, details refer to following test plot, and compliance is achieved as well.

Due to the small size of the product and that there are no inductive components of significant size, 9kHz to 30MHz frequency range is not tested based on technical judgment.

Test Plot of 100kHz Conducted Emissions, GFSK modulation

Low Channel

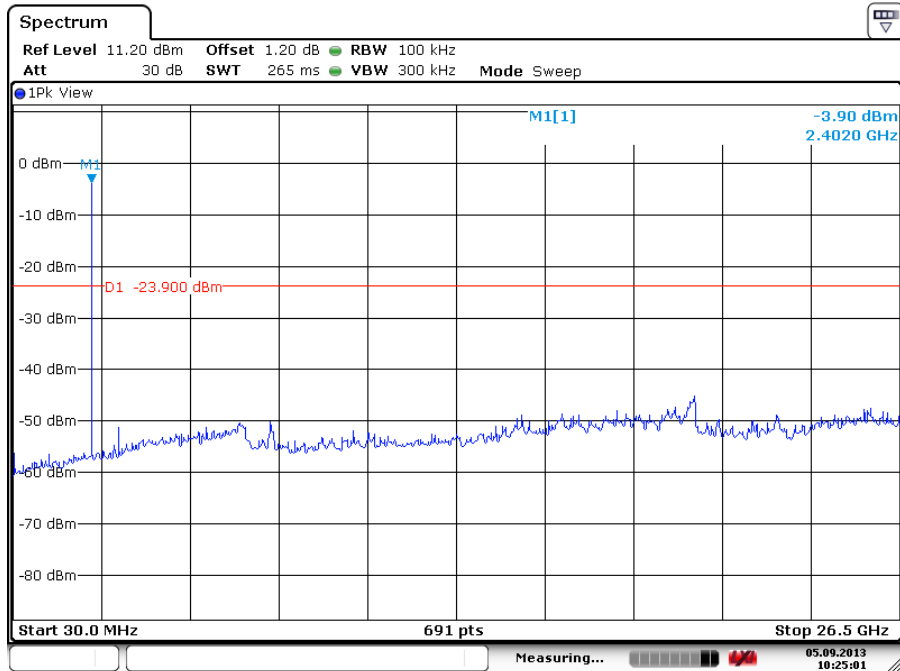

Date: 5.SEP.2013 10:25:01

Middle Channel

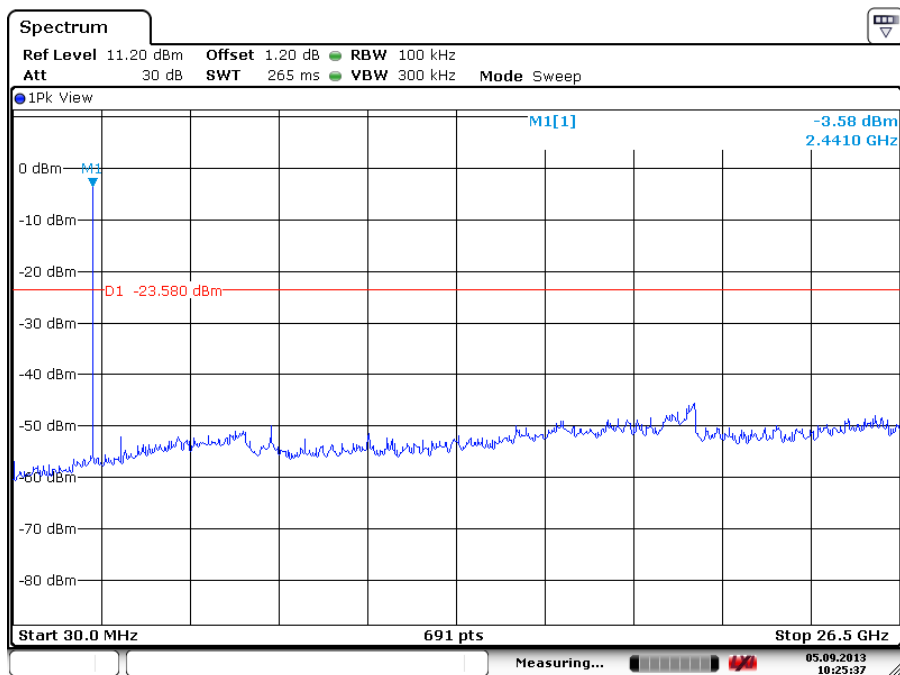

Date: 5.SEP.2013 10:25:37

High Channel

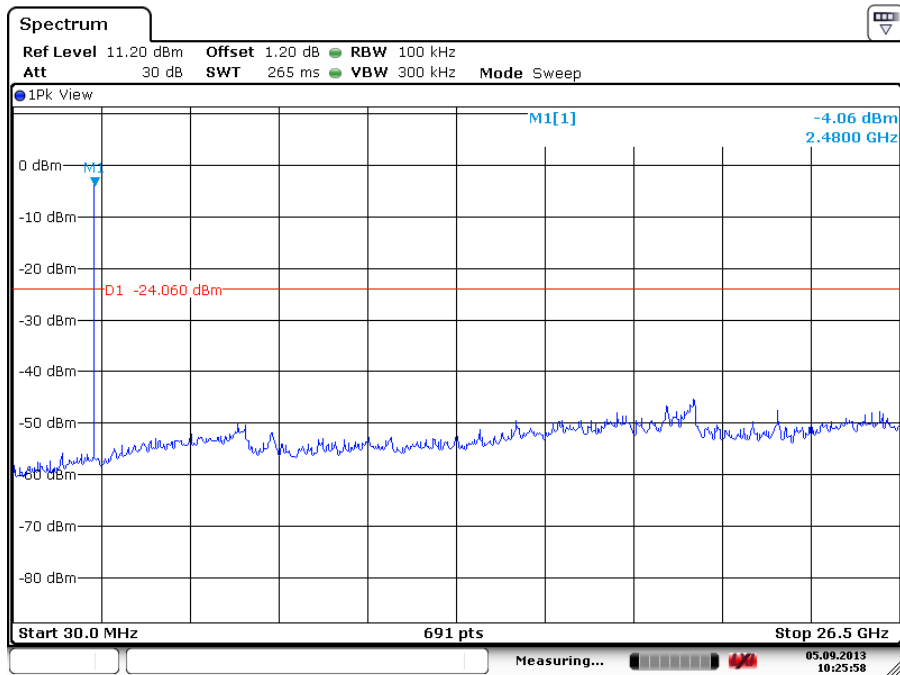

Date: 5.SEP.2013 10:25:58

Test Plot of 100kHz Conducted Emissions, 8DPSK modulation

Low Channel

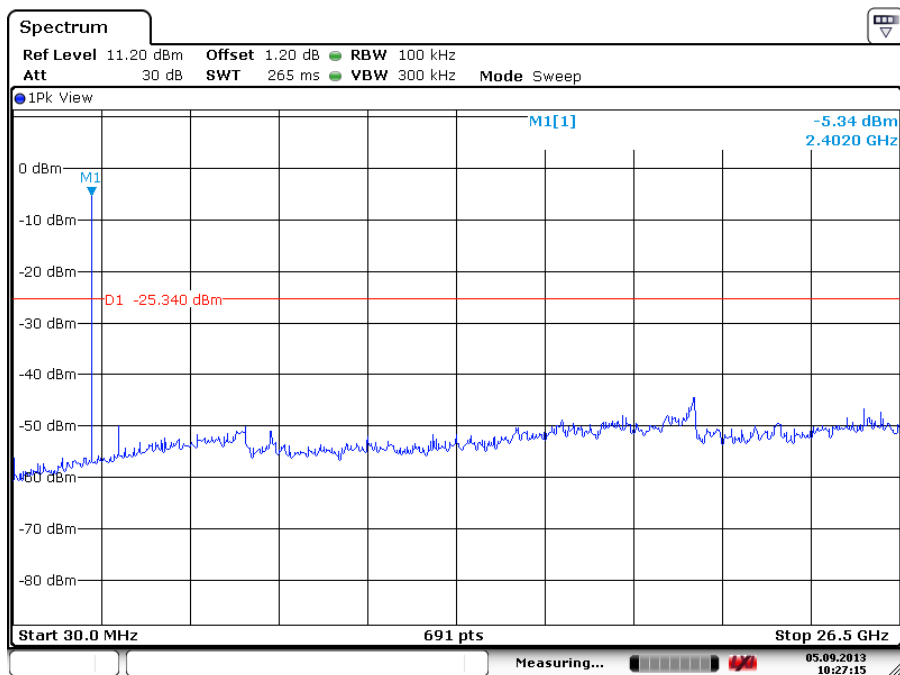

Date: 5.SEP.2013 10:27:15

Middle Channel

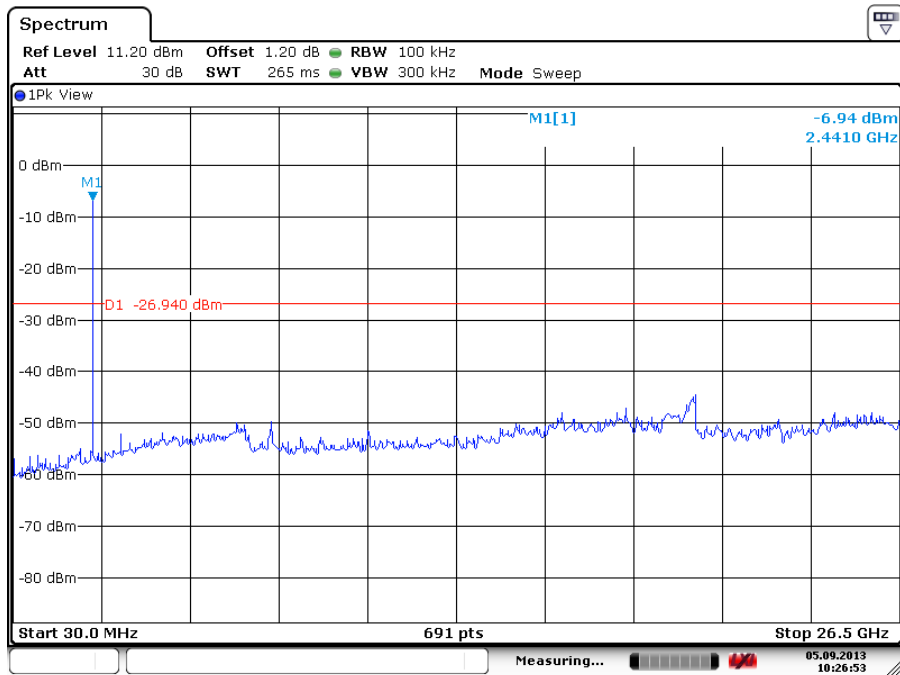

Date: 5.SEP.2013 10:26:53

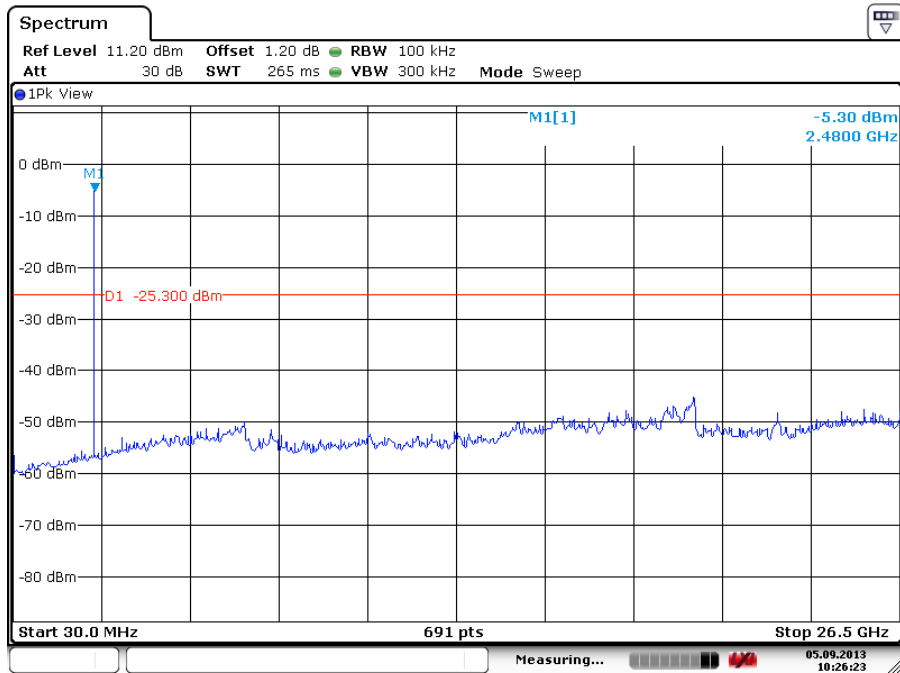
High Channel

Date: 5.SEP.2013 10:26:23

Test Plot of 100kHz Bandwidth of Frequency Band Edge, GFSK modulation

Low Channel

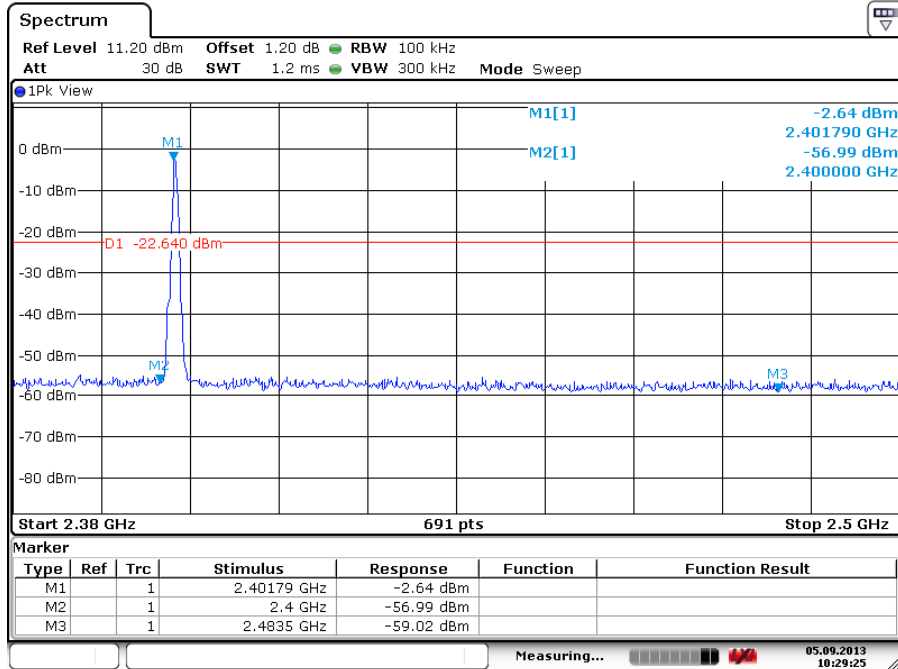

Date: 5.SEP.2013 10:29:25

High Channel

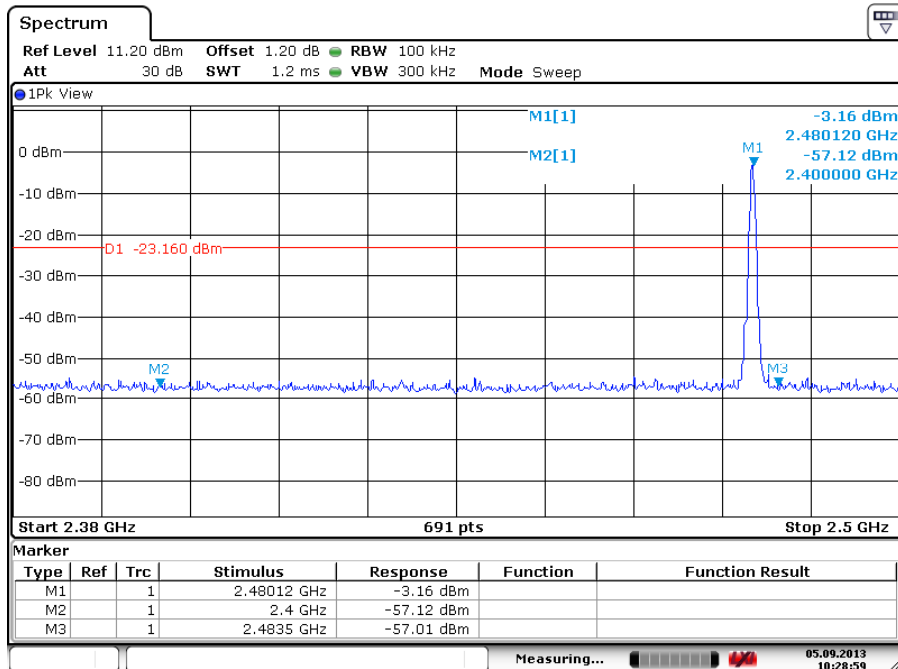

Date: 5.SEP.2013 10:28:59

Test Plot of 100kHz Bandwidth of Frequency Band Edge, 8DPSK modulation

Low Channel

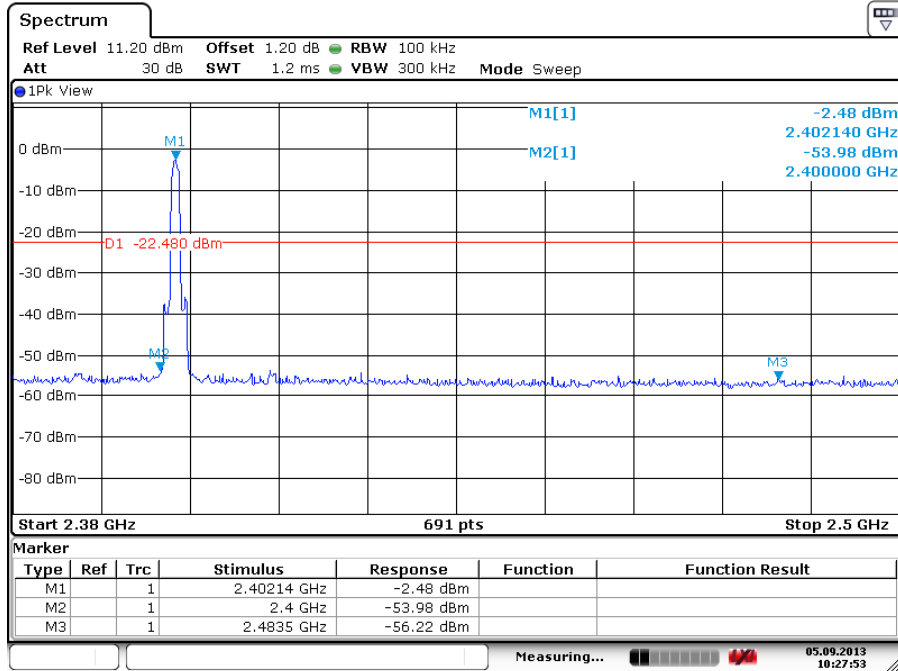

Date: 5.SEP.2013 10:27:53

High Channel

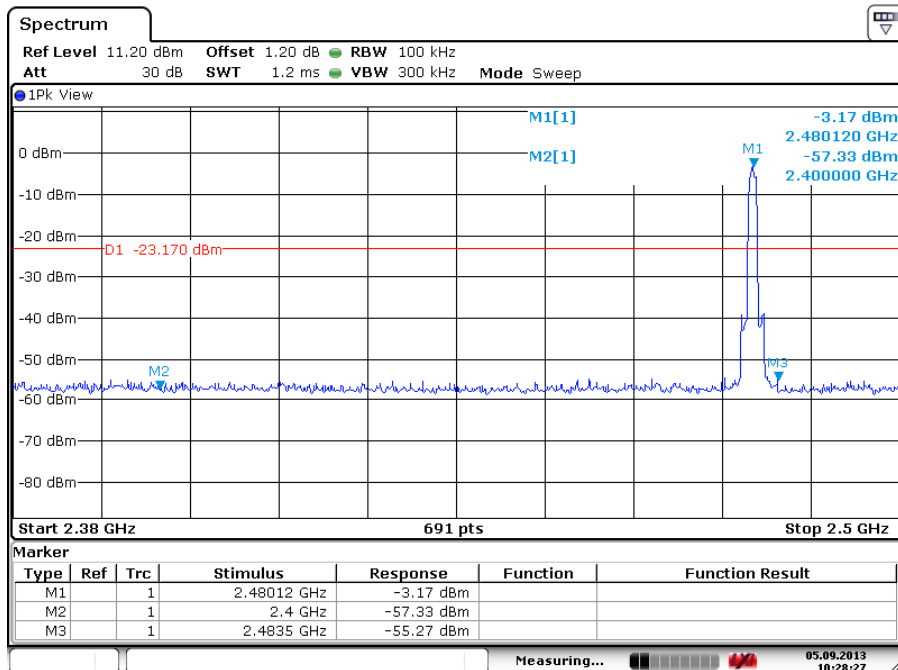

Date: 5.SEP.2013 10:28:26

5.1.6 Spurious Emission

RESULT:**Passed**

| | | |
|-------------------|---|--|
| Test standard | : | FCC part 15.247(d), FCC 15.205, FCC 15.209, RSS-210 2.2, RSS-210 A8.5 and RSS-Gen 7.2.1 |
| Basic standard | : | ANSI C63.10: 2009 |
| Limits | : | Radiated emissions which fall in the restricted bands, as defined in FCC 15.205(a) and RSS-210 2.7 (Table 1), must comply with the radiated emission limits specified in FCC 15.209(a) and RSS-210 2.7 (Table 2 and 3). Emission radiated outside the specified frequency bands must comply with the radiated emission limits specified in FCC 15.209(a) and FCC 15.249(a), RSS-210 2.7 (Table 2 and 3) and RSS-210 A2.9(a). |
| Kind of test site | : | 3m Semi-Anechoic Chamber |

Test setup

| | | |
|----------------------|---|-------------------|
| Test Channel | : | Low/ Middle/ High |
| Operation Mode | : | A |
| Ambient temperature | : | 22-26°C |
| Relative humidity | : | 50-65% |
| Atmospheric pressure | : | 100-103 kPa |

Remark: Testing was carried out within frequency range 30MHz to the tenth harmonic. For details refer to Appendix 2. The Radiated Emissions testing was performed in the X, Y and Z axis orientation. The X Axis orientation is the worst-case and recorded in this test report. Due to the small size of the product and that there are no inductive components of significant size, 9kHz to 30MHz frequency range is not tested based on technical judgment.

5.1.7 Frequency Separation

RESULT: **Passed**

Test standard : FCC part 15.247(a)(1), RSS-210 A8.1(b)
 Basic standard : DA 00-705 of March 30, 2000
 Limit : $\geq 25\text{kHz}$ or $2/3$ of 20dB bandwidth, whichever is greater

Test setup

Test Channel : Low/ Middle/ High
 Operation Mode : A
 Ambient temperature : 24°C
 Relative humidity : 53%

Table 13: Test result of Frequency Separation

| Channel | Channel Frequency (MHz) | Measured Channel Separation (MHz) | Limit (kHz) | Result |
|----------------------|-------------------------|-----------------------------------|--|--------|
| Record Channel | 2441 | 1 | $\geq 25\text{kHz}$ or $2/3$ of 20dB bandwidth | Pass |
| Record Channel adj 1 | 2440 | | | |
| Record Channel adj 2 | 2442 | | | |

Test Plot of Frequency Separation

GFSK

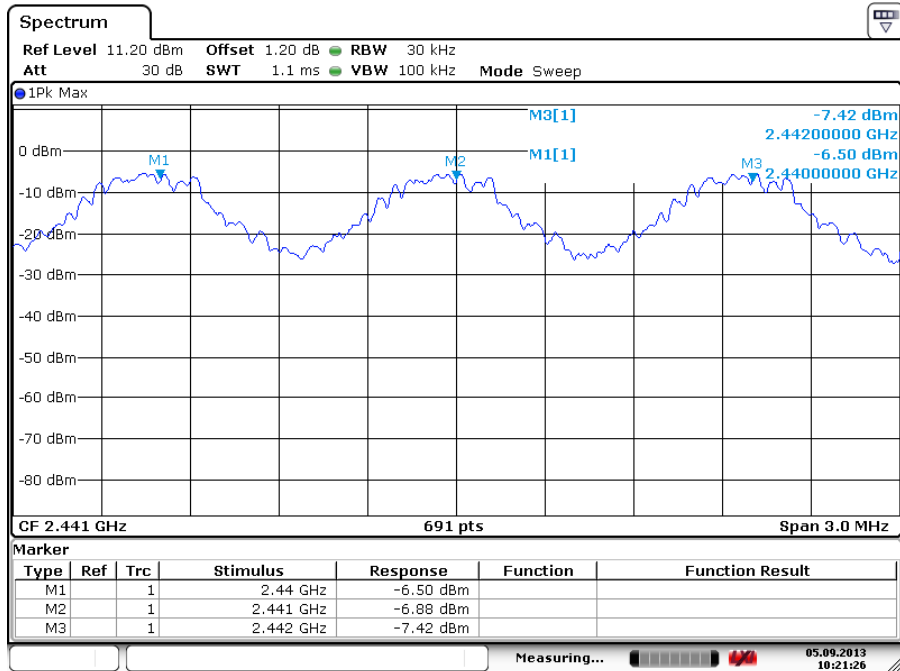

Date: 5.SEP.2013 10:21:26

5.1.8 Number of hopping frequency

RESULT:
Passed

Test standard : FCC part 15.247(a)(1)(iii), RSS-210 A8.1(d)
 Basic standard : DA 00-705 of March 30, 2000
 Limits : ≥ 15 non-overlapping channels
 Kind of test site : Shield room

Test setup

Test Channel : Low/ Middle/ High
 Operation Mode : A

 Ambient temperature : 22-26°C
 Relative humidity : 50-65%
 Atmospheric pressure : 100-103 kPa

Table 14: Test result of Number of hopping frequency

| Frequency Range | Measured Quantity of Hopping Channel | Limit | Result |
|----------------------------------|--------------------------------------|-----------|--------|
| <u>2400</u> to <u>2483.5</u> MHz | 79 | ≥ 15 | Pass |

Test Plot of Number of hopping frequencies

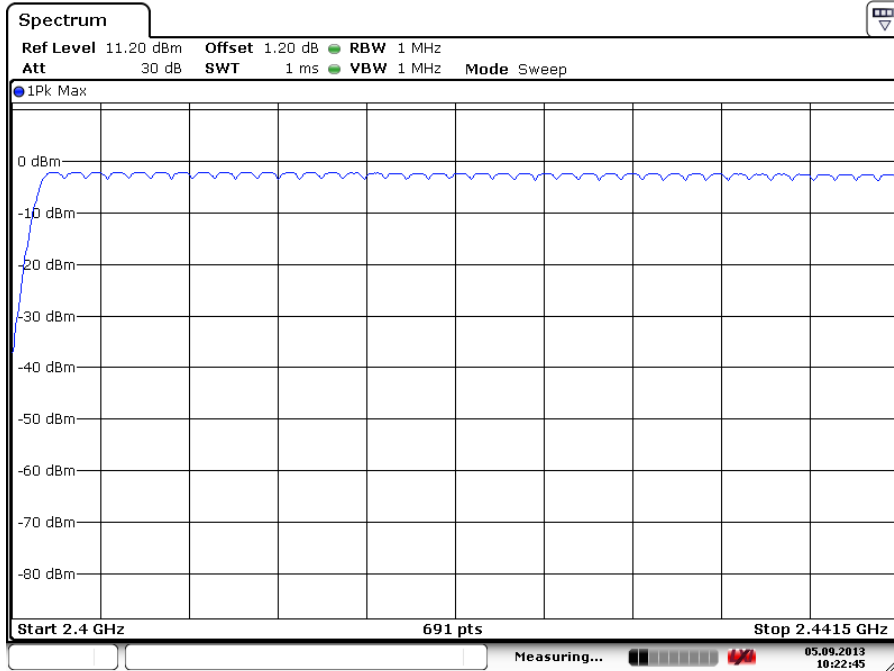

Date: 5.SEP.2013 10:22:45

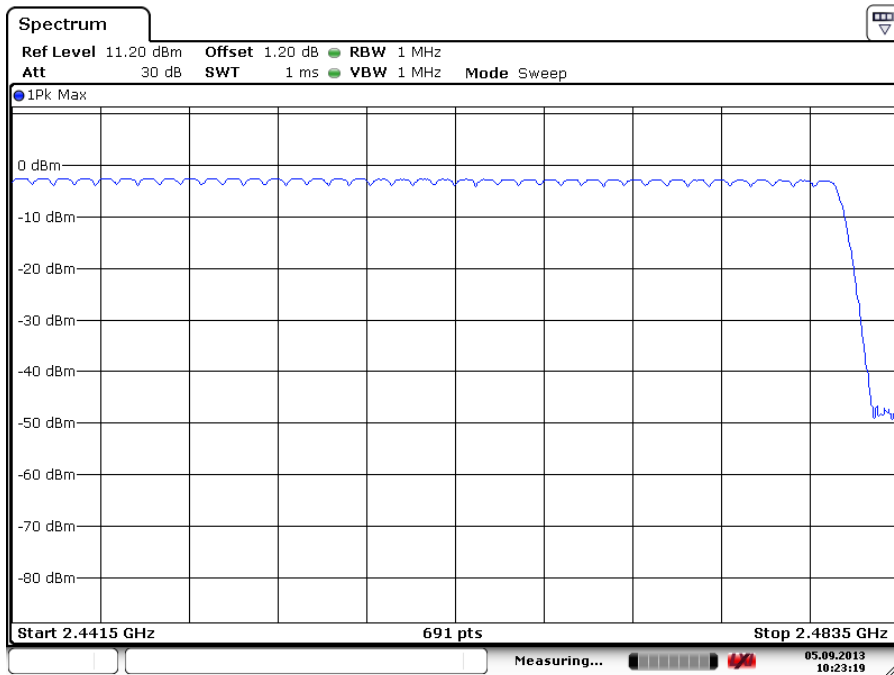

Date: 5.SEP.2013 10:23:19

5.1.9 Time of Occupancy

RESULT:
Passed

Test standard : FCC part 15.247(a)(1)(iii) , RSS-210 A8.1(d)
 Basic standard : DA 00-705 of March 30, 2000
 Limits : 0.4s
 Kind of test site : Shield room

Test setup

Test Channel : Low/ Middle/ High
 Operation Mode : A

 Ambient temperature : 22-26°C
 Relative humidity : 50-65%
 Atmospheric pressure : 100-103 kPa

Table 15: Test result of Time of Occupancy

| Data Mode | Captured Burst (s) | Dwell time (s) | On+Off time (s) | Limit (s) | Result |
|-----------|--------------------|----------------|-----------------|-----------|--------|
| DH5 | 0.0029 | 0.3135 | 0.003754 | 0.4 | Pass |
| 3DH5 | 0.0030 | 0.3157 | 0.003783 | 0.4 | Pass |

Note:

Dwell time = Pulse width x (Hopping rate / Number of channels) x Period

Period = 0.4 (seconds/ channel) x 79 (channel) = 31.6 seconds.

Test Plot of Time of Occupancy, GFSK modulation

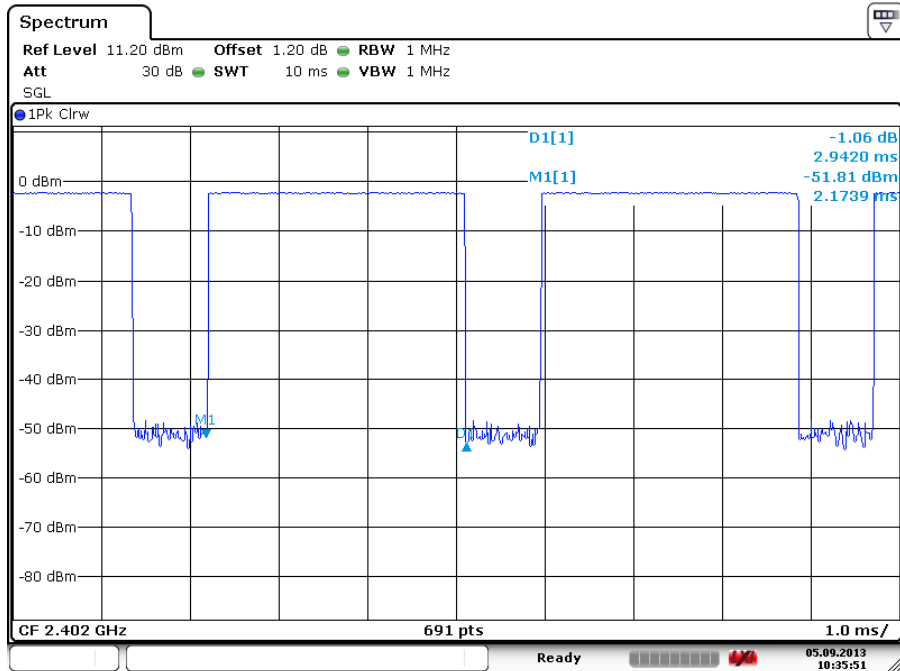

Date: 5.SEP.2013 10:35:51

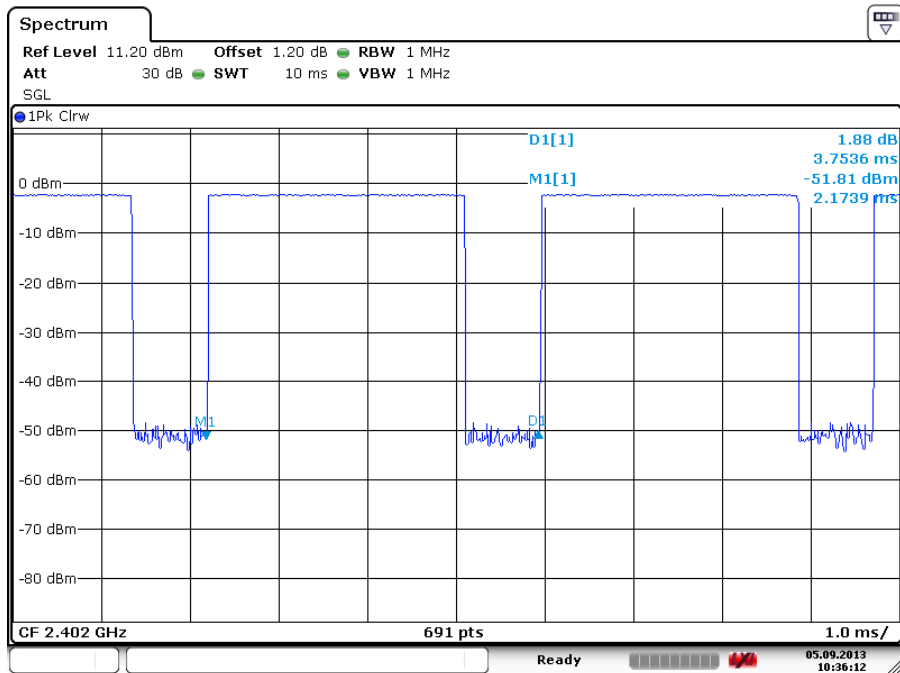

Date: 5.SEP.2013 10:36:12

Test Plot of Time of Occupancy, 8DPSK modulation

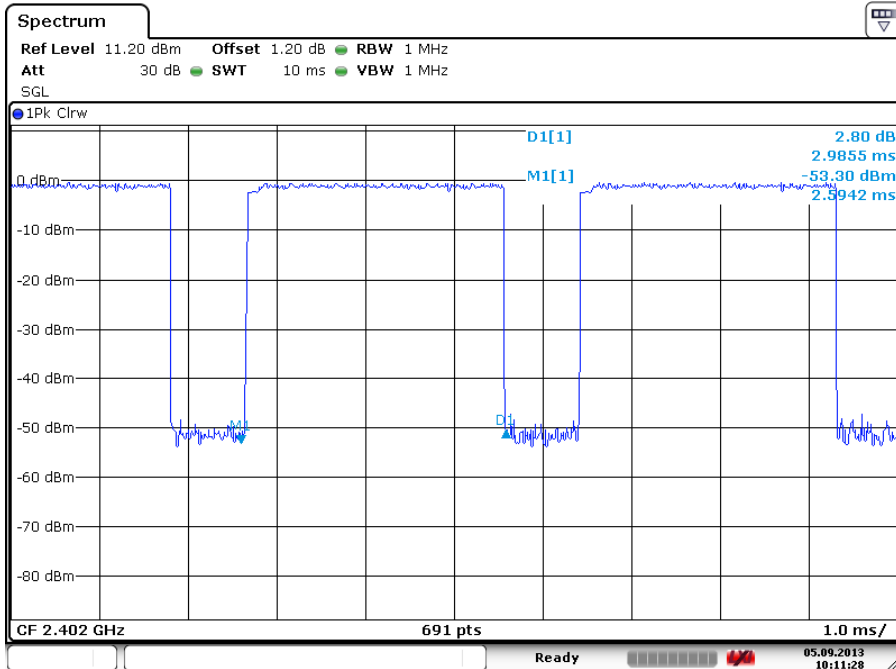

Date: 5.SEP.2013 10:11:28

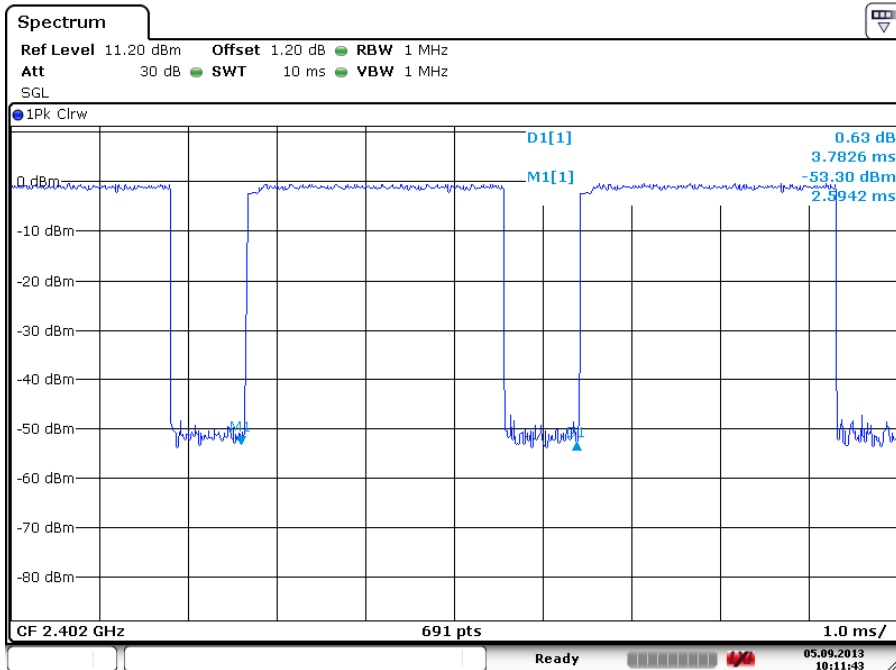

Date: 5.SEP.2013 10:11:43

5.2 Mains Emissions

5.2.1 Mains Conducted Emissions

RESULT:**Passed**

Test standard : FCC Part 15.207
FCC Part 15.107
LP0002: 2.3

Limits : Mains Conducted emissions as defined in
above standards

Kind of test site : Shielded Room

Test setup

Test Channel : Middle
Operation mode : A

Remark: For details refer to Appendix D.

6. Safety Human exposure

6.1 Radio Frequency Exposure Compliance

6.1.1 Electromagnetic Fields

RESULT:**Passed**

Test standard : FCC KDB Publication 447498

Since maximum average output power of the transmitter is <1mW, hence the EUT is excluded from SAR evaluation according to FCC KDB publication 447498 D01: Mobile Portable RF Exposure..

7. Photographs of the Test Set-Up

Photograph 1: Set-up for Spurious Emissions (Front View)

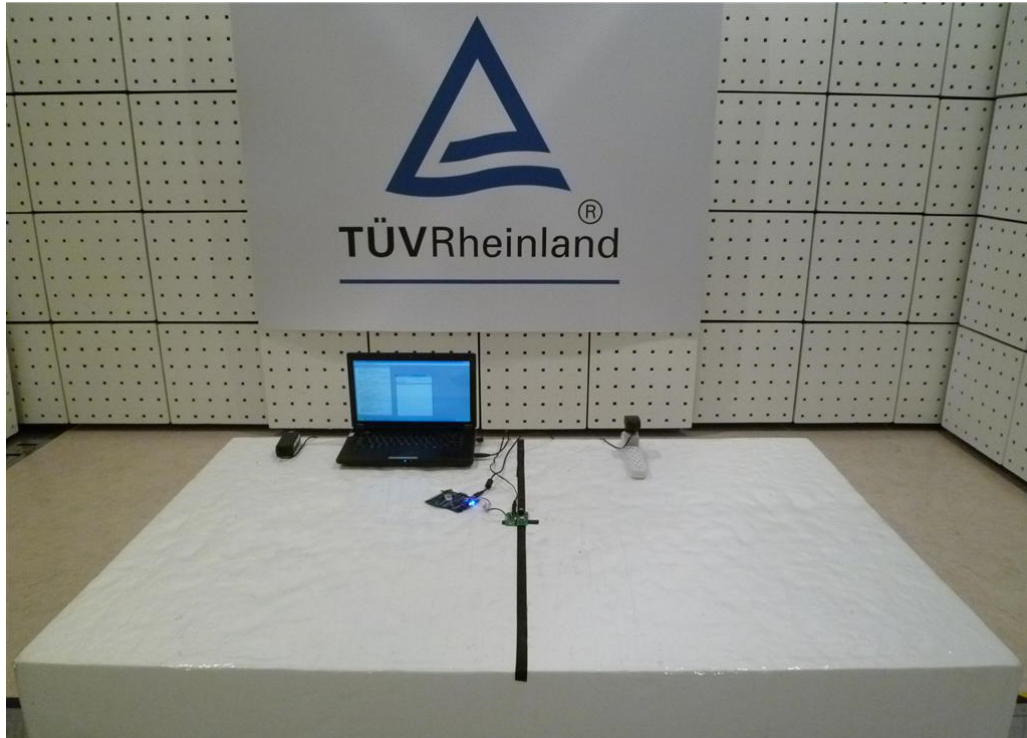

Photograph 2: Set-up for Spurious Emissions (Back View 1)



Photograph 3: Set-up for Spurious Emissions (Back View 2)



Photograph 4: Set-up for Conducted testing

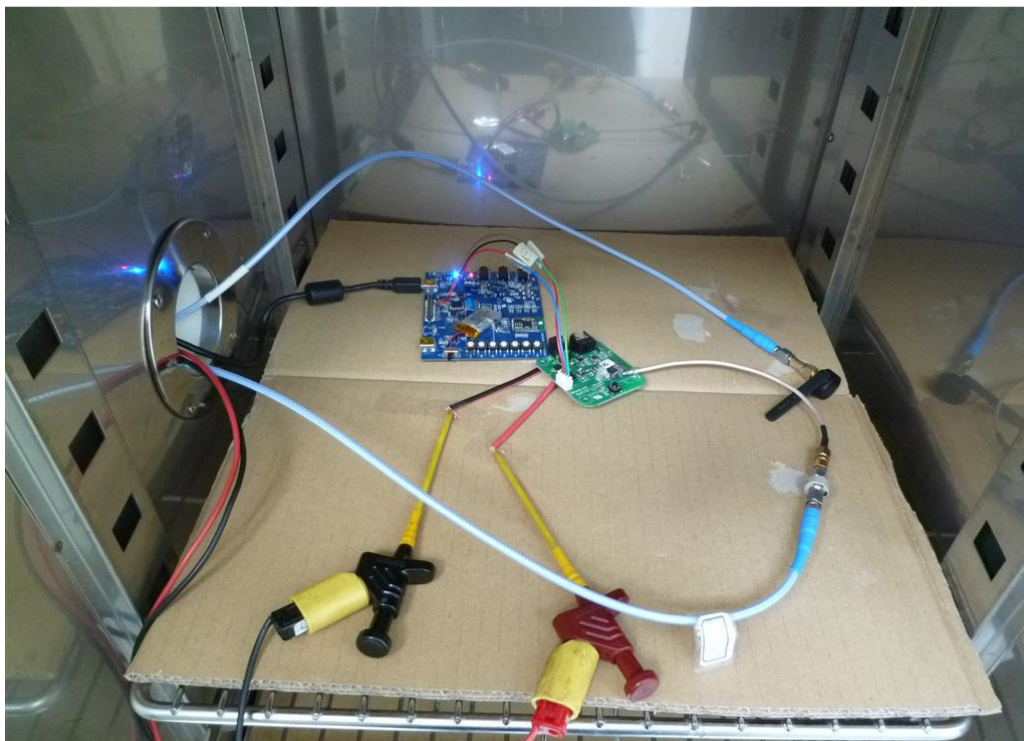

Photograph 5: Set-up for for Mains Conducted testing Back



Photograph 6: Set-up for for Mains Conducted testing Front



8. List of Tables

| | |
|--|----|
| Table 1: Applied Standard and Test Levels | 5 |
| Table 2: List of Test and Measurement Equipment | 6 |
| Table 3: Emission Measurement Uncertainty..... | 7 |
| Table 4: Technical Specification of EUT | 8 |
| Table 5: Frequency hopping information..... | 9 |
| Table 6: Test result of Peak Output Power, GFSK modulation..... | 15 |
| Table 7: Test result of Peak Output Power, 8DPSK modulation..... | 15 |
| Table 8: Test result of 20dB Bandwidth, GFSK modulation..... | 19 |
| Table 9: Test result of 20dB Bandwidth, 8DPSK modulation..... | 19 |
| Table 10: Test result of 99% Bandwidth, GFSK modulation..... | 24 |
| Table 11: Test result of 99% Bandwidth, PSK modulation..... | 24 |
| Table 12: Test result of Frequency Separation | 35 |
| Table 13: Test result of Number of hopping frequency | 37 |
| Table 14: Test result of Time of Occupancy..... | 39 |

9. List of Photographs

| | |
|---|----|
| Photograph 1: Set-up for Spurious Emissions (Front View)..... | 44 |
| Photograph 2: Set-up for Spurious Emissions (Back View 1) | 45 |
| Photograph 3: Set-up for Spurious Emissions (Back View 2) | 46 |
| Photograph 4: Set-up for Conducted testing | 46 |
| Photograph 5: Set-up for for Mains Conducted testing Back..... | 47 |
| Photograph 6: Set-up for for Mains Conducted testing Front..... | 47 |