



**STORM
CRUSHER**

CAUTION-ELECTRIC TOY:

Not recommended for children under 8 years of age. As with all electric products, precautions should be observed during handling and use to prevent electric shock.

**CAUTION-SUPERVISION
REQUIRED-ELECTRIC TOY-
UNPLUG WHEN NOT IN USE.
INPUT: 120V AC, 60HZ, 300mA
OUTPUT: 12V DC, 500mA**

**ATTENTION PARENTS:
IT IS RECOMMENDED THAT THIS TOY AND
ALL ACCESSORIES BE PERIODICALLY
EXAMINED FOR POTENTIAL HAZARDS AND
THAT ANY POTENTIALLY HAZARDOUS PARTS
BE REPAIRED OR REPLACED.**

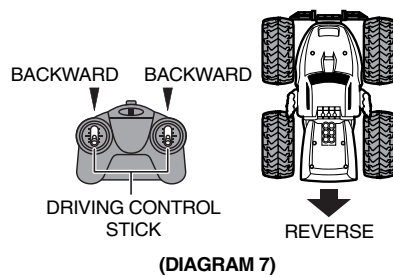
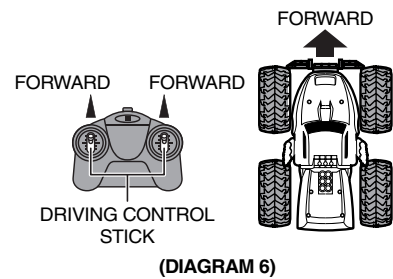

STEERING OPERATION

- Push only the Left Driving Control Stick forward to turn Right. (See Diagram 8)
- Push only the Right Driving Control Stick forward to turn Left. (See Diagram 9)

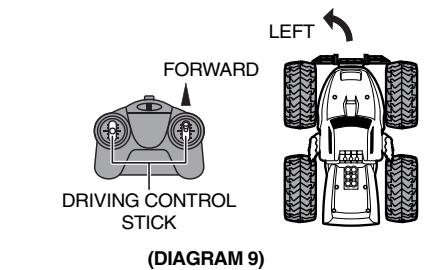
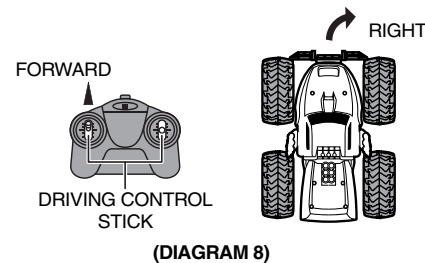

360 DEGREE SPINS

- Push the Left Driving Control Stick forward while pulling the Right Driving Control Stick backward at the same time. (See Diagram 10)
- Push the Right Driving Control Stick forward while pulling the Left Driving Control Stick backward at the same time. (See Diagram 11)

OPERATING INSTRUCTIONS:



TRY ME UNIT:

Try Me button box is for demonstration purpose only. Dispose of this unit by detaching the wires connecting to the car before playing.

BATTERY PACK CARE / CAUTIONS:

- If battery pack and/or connectors are wet, thoroughly dry before charging.
- Unplug the battery pack if it is not going to be used for several days.
- Do not charge battery pack that is hot, wet or shows signs of leakage or corrosion.
- Do not expose to fire, as explosion may result.
- Do not disassemble the battery pack.
- Rechargeable battery pack is only to be charged by adults.

BATTERY INSTALLATION:

IMPORTANT: FOR MAXIMUM PERFORMANCE, YOU MUST FULLY CHARGE BATTERY PACK BEFORE FIRST TIME USE.

THE RECHARGEABLE NI-MH BATTERY PACK IS NOT CHARGED. PLEASE CHARGE IT FOR 3 HOURS PRIOR TO USE.

- Plug the wall pack battery charger into wall outlet. (See Diagram 1)
- Click the battery pack into the charger. Make certain the battery pack is secure in charger.
- To disconnect, push the button of the charger (See Diagram 1) and simultaneously slide battery pack out.
- Allow about 3 hours full-charge. The red light indicator keeps light up continuously when charging is in process.

- The charging is complete when the red light keeps flashing. Then unplug the charger and pull apart the battery connectors.
- After charging for about 3 hours, the battery will be warm. This condition is normal for fully charged batteries.
- If the speed of the car slows down suddenly, it is time to recharge.
- After use, the battery pack will be hot! Wait at least 20 minutes until it cools before recharging. Recharging a warm or hot battery pack will greatly shorten the battery life.

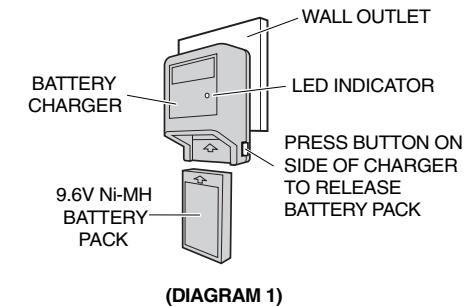

VEHICLE:

- Make sure the "ON/OFF" switch at the underside of the vehicle is at the "OFF" position. (See Diagram 2)
- Unscrew to open the battery cover. (See Diagram 2)
- Insert the 9.6V Ni-MH battery pack into battery compartment. (See Diagram 3)
- Replace the battery cover and tighten the screw to secure the battery cover.

PERFORMANCE TIPS FOR VEHICLE

- Do not drive car on grass, sand or carpet.
- Do not drive car through water.
- Be sure to rest your vehicle for at least 30 minutes after every 15 minutes of operation.
- Make sure ON/OFF switch on your vehicle is in the "OFF" position when it is not in use.
- Do not bend the antenna.
- Electrical, CB interference, mobile phones, air conditioning, elevators and steel girders in buildings will affect the operation of your vehicle.
- Do not leave the vehicle or transmitter near sources of heat or in direct sunlight for long periods of time.
- Remove the batteries from the vehicle and transmitter when they are not in use.

CAUTION-ELECTRIC TOY:
Not recommended for children under 8 years of age. As with all electric products, precautions should be observed during handling and use to prevent electric shock.

CAUTION- SUPERVISION REQUIRED-ELECTRIC TOY-UNPLUG WHEN NOT IN USE.

INPUT: 120V AC, 60Hz, 300mA
OUTPUT: 12V DC, 500mA

www.toysrus.com

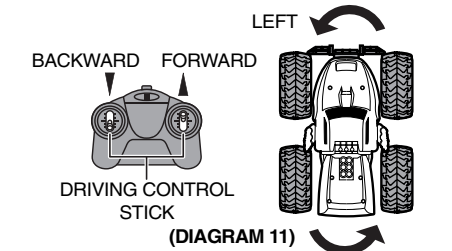
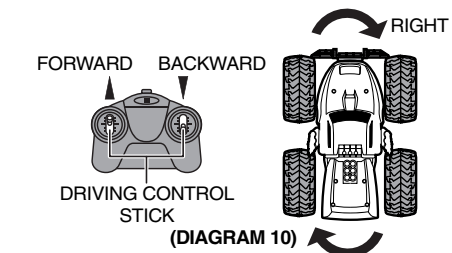

STOP OPERATION

- Release both Driving Control Sticks, the vehicle will Stop. (See Diagram 12)

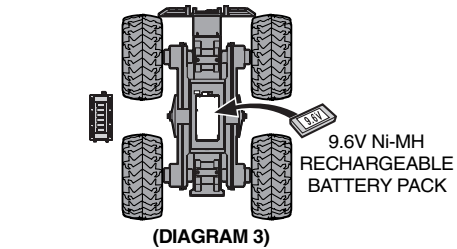
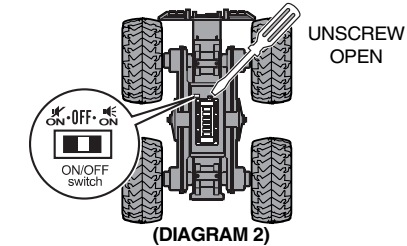
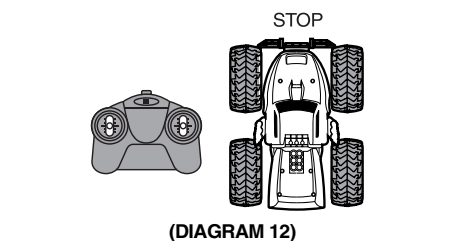

TRANSMITTER:

- Unscrew to open the battery cover at the back and install a 9V battery by matching the + and - signs as indicated in the battery compartment. (See Diagram 4)
- Replace the battery cover and tighten the screw to secure the battery cover.

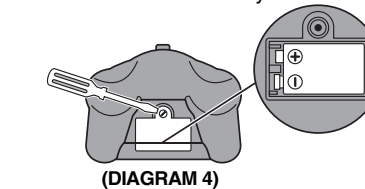

HOW TO PLAY

START TO PLAY

PAIRING TRANSMITTER WITH VEHICLE

- Turn ON the vehicle (See Diagram 5).
- Install a 9V battery in the transmitter, the pairing LED light on the transmitter will flash.
- If pairing is successful, the pairing LED light will turn OFF.
- You must pair the transmitter with the vehicle within 45 seconds, after 45 seconds you must push the control on the transmitter to pair again.
- You must repeat pairing again whenever replacing the transmitter's battery.

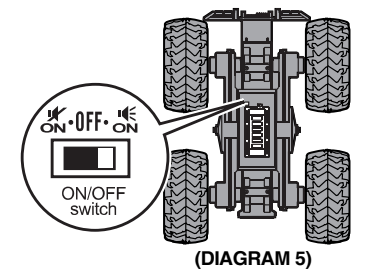

FORWARD RUNNING

- Push both the Driving Control Sticks forward for forward running. (See Diagram 6)

REVERSE RUNNING

- Pull both the Driving Control Sticks backward for reverse running. (See Diagram 7)

This device complies with Part 15 of the FCC Rules. Operation is subject to the following two conditions:
(1) this device may not cause harmful interference, and
(2) this device must accept any interference received, including interference that may cause undesired operation.
Warning: Changes or modifications to this unit not expressly approved by the party responsible for compliance could void the user's authority to operate the equipment.
NOTE: This equipment has been tested and found to comply with the limits for a Class B digital device, pursuant to Part 15 of the FCC Rules. These limits are designed to provide reasonable protection against harmful interference in a residential installation. This equipment generates, uses and can radiate radio frequency energy and, if not installed and used in accordance with the instructions, may cause harmful interference to radio communications. However, there is no guarantee that interference will not occur in a particular installation. If this equipment does cause harmful interference to radio or television reception, which can be determined by turning the equipment off and on, the user is encouraged to try to correct the interference by one or more of the following measures:

- Reorient or relocate the receiving antenna.
- Increase the separation between the equipment and receiver.
- Connect the equipment into an outlet on a circuit different from that to which the receiver is connected.
- Consult the dealer or an experienced radio/TV technician for help.

IMPORTANT

If you experience any problems or issues with this item, do not take it back to the store where you purchased. Please email service@scientific.com.hk and we will be happy to assist you in resolving any issues you may have. We thank you for your purchase.

8+ **ToysRUs®**

CONFORMS TO THE SAFETY REQUIREMENTS OF ASTM F963.

9.6V

Contents and colors may vary.

Batteries are demonstration purposes only. They should be replaced upon purchase for optimal performance.

Ev x1 INCLUDED

Do not mix old and new batteries. Do not mix alkaline, standard (carbon-zinc), or rechargeable batteries.

FAST LANE IS A MARK OF (EST UNE MARQUE DE/ ES UNA MARCA DE) GEOFFREY, LLC, A SUBSIDIARY OF (UNE FILIALE DE/UNA SUBSIDIARIA DE) TOYS"R"US, INC. © 2017 GEOFFREY, LLC
MADE IN CHINA (FABRIQUÉE EN CHINE/FABRICADO EN CHINA)
DISTRIBUTED IN THE UNITED STATES BY (DISTRIBUÉE AUX ÉTATS-UNIS PAR/DISTRIBUIDO EN LOS ESTADOS UNIDOS POR) TOYS"R"US, INC., WAYNE, NJ 07470
IMPORTED BY (IMPORTÉ PAR/IMPORTADO EM) TOYS"R"US (CANADA) LTD. (LTÉE), 2777 LANGSTAFF ROAD, CONCORD, ON L4K 4M5
DISTRIBUTED IN AUSTRALIA BY (DISTRIBUÉE EN AUSTRALIE PAR/ DISTRIBUIDO EN AUSTRALIA POR) TOYS"R"US (AUSTRALIA (AUSTRALIE)) PTY LTD. (LTÉE), REGENTS PARK NSW 2143
www.toysrus.com www.toysrus.ca