

# 第1摺

## OPERATING INSTRUCTIONS

**INSTRUCTION SHEET & PACKAGING MUST BE RETAINED SINCE IT CONTAINS IMPORTANT INFORMATION:**

### BATTERY INSTALLATION

#### BATTERY REQUIREMENT:

Vehicle: Built-in Rechargeable Battery

Transmitter: 2 x AA batteries (included) \*ALKALINE AA BATTERIES IS RECOMMENDED

### ATTENTION PARENTS

It is recommended that this toy and all accessories be periodically examined for potential hazards and that any potentially hazardous parts be repaired or replaced.

### VEHICLE

The vehicle is powered by a built-in non-replaceable rechargeable battery. The included rechargeable battery is not charged prior to shipment and must be charged before the first use.

### Charging The Vehicle

1. Make sure the vehicle's ON/OFF switch is in the OFF position. (See Diagram 1)
2. Open the battery cover. (See Diagram 1)
3. Plug the charging cable USB socket to an USB certified port, i.e., desktop computer / laptop computer / smartphone charger / tablet charger / car charger
4. Turn the vehicle's ON/OFF switch to "CHARGE" position.
5. The LED light on car body will flash to show vehicle is charging.
6. Once the light turned OFF, the vehicle is fully charged. Unplug the USB socket from the USB certified port.
7. Put back the charging cable into the compartment and replace battery cover. (See Diagram 3)

### TRANSMITTER

1. Unscrew to open the battery lid. Insert a new 2 x AA batteries. (See Diagram 2)
2. Replace the battery cover.

Note: Remove battery after you have finished using your vehicle.

### Caution : Built-In Battery Safety Information

1. The vehicle includes a non-replaceable battery. Do not open, disassemble or alter the vehicle in anyway.
2. Adult supervision is required when charging the vehicle.
3. Charge battery in isolated area. Keep away from flammable materials.
4. Do not expose to direct sunlight.
5. Do not recharge the toy if it is hot. Allow it to cool before recharge.
6. Do not allow the batteries to get wet.
7. Carefully read the instruction guide and use the batteries correctly.
8. Rechargeable batteries are only to be charged under adult supervision.
9. Routine examination for damage to the plug, enclosure and other parts. In the event of any damage, the toy must not be used with USB port until the damage has been repaired.
10. This toy is not intended for children under 3 years old.

### CARE

Never drive the vehicle on a wet floor, on sand, grass, carpet, in mud, rain or snow. These can cause damage to the vehicle. Do not expose the vehicle to extreme temperatures. To protect the vehicle's wheel mechanisms from lint and hair, do not drive it on carpet. Occasionally wipe the vehicle with a damp cloth to remove any dirt/dust from wheels. Do not use harsh chemicals to clean the vehicle. Modifying or tampering with the vehicle or the transmitter's internal components can cause a malfunction.

### HELPFUL HINTS

Running the vehicle continuously for long periods of time generates high levels of heat. Heat causes wear and tear on the motor. When the vehicle's battery pack goes flat, let the vehicle cool at least 10 minutes before installing a newly charged battery pack. This helps keep heat levels down. If the vehicle's motor runs but does not respond to the transmitter, move the transmitter closer to the vehicle and try again. If a CB radio is used nearby, it might interfere with the control of the vehicle. If this happens, move the vehicle and transmitter away from the CB radio. The vehicle cannot be operated near devices with transmitters that use the same frequency. Check the packaging to see which frequency your vehicle uses. If the vehicle moves slowly, and a recharged battery pack has been installed, check the wheel mechanisms for lint, thread, hair or dust.

## HOW TO PLAY

### START TO PLAY

#### PAIRING TRANSMITTER WITH VEHICLE

1. Turn ON the vehicle (See Diagram 3).
2. Install 2 x AA battery in the transmitter, the pairing LED light on the transmitter will flash (See Diagram 2).
3. If pairing success, the pairing LED light will turn OFF
4. You must pairing the transmitter with the vehicle within 45 seconds, after 45 seconds you must push the control on the transmitter to pair again.
5. You must repeat pairing again when the transmitter needs to replace new batteries.

#### Notes:

1. If pairing failed, reinstall the battery of transmitter, move closer and then try again.
2. If more than one vehicle are pairing at the same time, pair each vehicle one by one.

Vehicle has memory to store the paired data, no need to pair each time play until replace the battery in transmitter.

### OPERATION

1. Operate the vehicle with the transmitter (See Diagram 4).
2. Turn OFF the vehicle and the transmitter after playing and remove all batteries from the transmitter.

### FRONT WHEELS STEERING ADJUSTMENT

1. If the vehicle does not run straight forwards, adjust the lever for satisfactory alignment on the underside of the vehicle. (See Diagram 5)
2. If the vehicle runs towards left, turn "Steering Alignment Lever" towards "R"
3. If the vehicle runs towards right, turn "Steering Alignment Lever" towards "L"

Keep packaging as it contains important information.

#### CAUTION: To prevent battery leakage:

Be sure to insert batteries correctly and always follow the product and battery manufacturers' instructions. Never mix old and new batteries (replace all batteries at the same time).

Never mix Alkaline, standard (Carbon Zinc) or rechargeable (Nickel-Metal Hydride) batteries.

Only batteries of the same or equivalent type as recommended are to be used.

Do not use RECHARGEABLE batteries, unless specified.

Non-rechargeable batteries are not to be recharged.

Rechargeable batteries are to be removed from the product before being charged.

Rechargeable battery is only to be charged by adults or by children at least 8 years old.

Always remove exhausted or dead batteries from the product.

Remove batteries from product before extended storage.

The supply terminals are not to be short-circuited.

Batteries are to be inserted with correct polarity.

Batteries may explode or leak if misused.

ATTENTION: Battery / Batteries should be installed by an adult only.

ATTENTION: User should remove the battery from the item before disposal.

This appliance is not intended for use by persons (including children) with reduced physical, sensory or mental capabilities, or lack of experience and knowledge, unless they have been given supervision or instruction concerning use of the appliance by a person responsible for their safety.

• The WEEE symbol if present indicates that this item contains electrical or electronic components which must be collected and disposed of separately.

• Never dispose of electrical or electronic waste in general municipal waste. Collect and dispose of such waste separately.

• Make use of the return and collection systems available to you, or your local recycling programme. Contact your local authority or place of purchase to find out what schemes are available.

• Electrical and electronic equipment contains hazardous substances which, when disposed of incorrectly, may leak into the ground. This can contribute to soil and water pollution which is hazardous to human health, and endanger wildlife.

• It is essential that consumers look to re-use or recycle electrical or electronic waste to avoid it going to landfill sites or incineration without treatment.

### NOT SUITABLE FOR CHILDREN UNDER 3 YEARS OF AGE, DUE TO SMALL PARTS.

### FCC Information

NOTE: This equipment has been tested and found to comply with the limits for a Class B digital device, pursuant to Part 15 of the FCC Rules. These limits are designed to provide reasonable protection against harmful interference in a residential installation. This equipment generates, uses, and can radiate radio frequency energy and, if not installed and used in accordance with the instructions, may cause harmful interference to radio communications. However, there is no guarantee that interference will not occur in a particular installation. If this equipment does cause harmful interference to radio or television reception, which can be determined by turning the equipment off and on, the user is encouraged to try to correct the interference by one or more of the following measures:

- Reorient or relocate the receiving antenna.
- Increase the separation between the equipment and receiver.
- Connect the equipment into an outlet on a circuit different from that to which the receiver is connected.
- Consult the dealer or an experienced radio/TV technician for help.

If you cannot eliminate the interference, the FCC requires that you stop using your equipment.

Warning: Changes or modifications not expressly approved by the party responsible for compliance could void the user's authority to operate the equipment. This device complies with Part 15 of the FCC Rules. Operation is subject to the following two conditions: (1) this device may not cause harmful interference, and (2) this device must accept any interference received, including interference that may cause undesired operation.

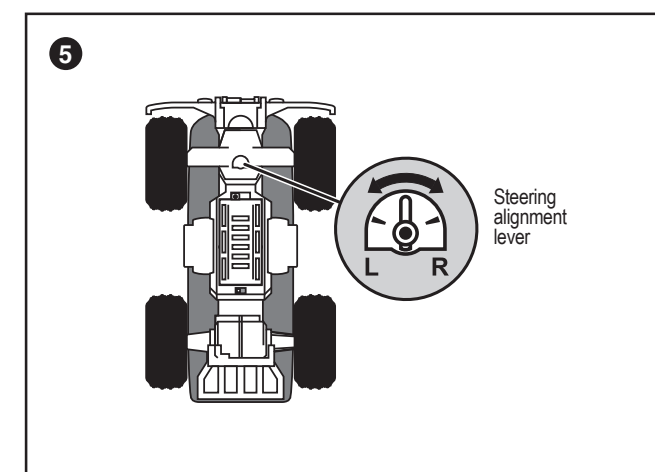
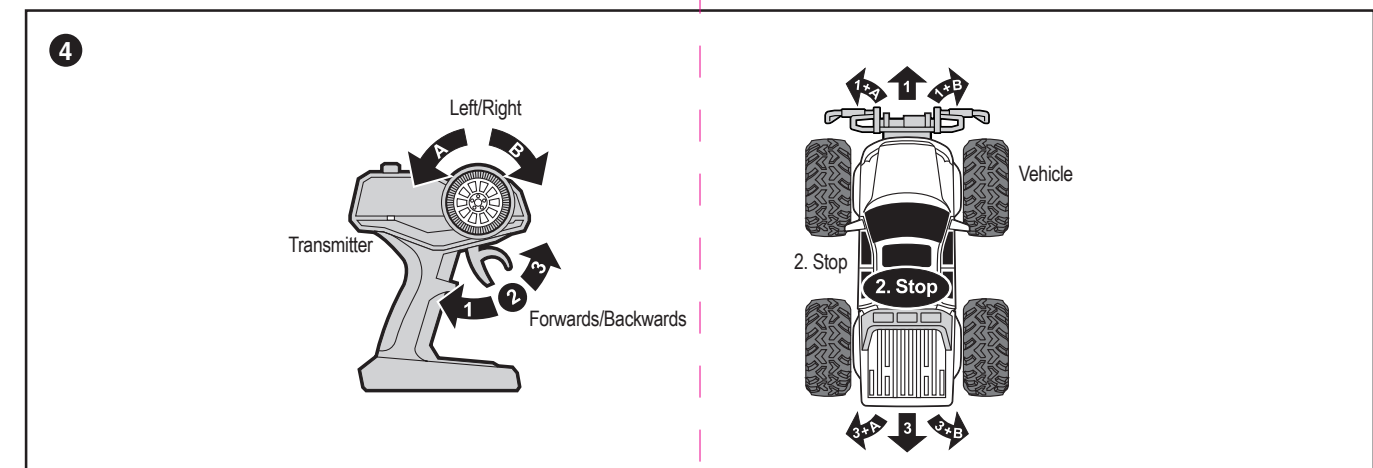
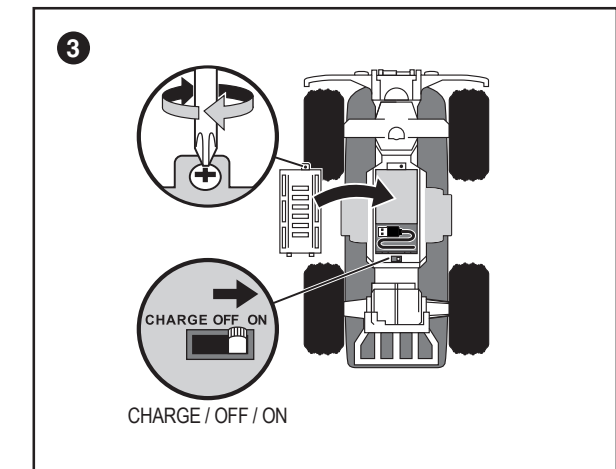
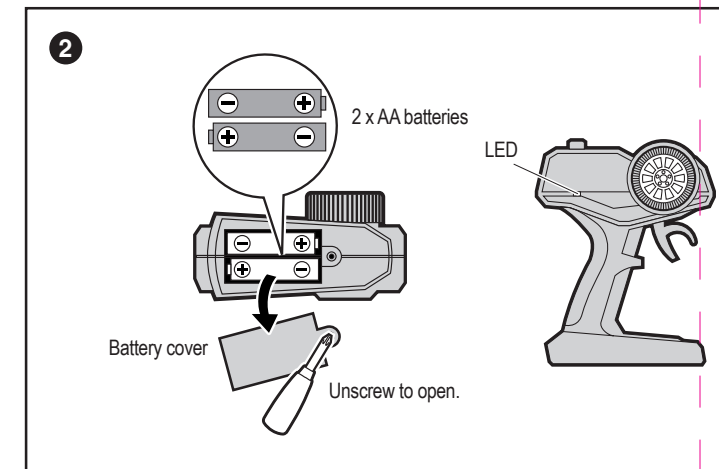
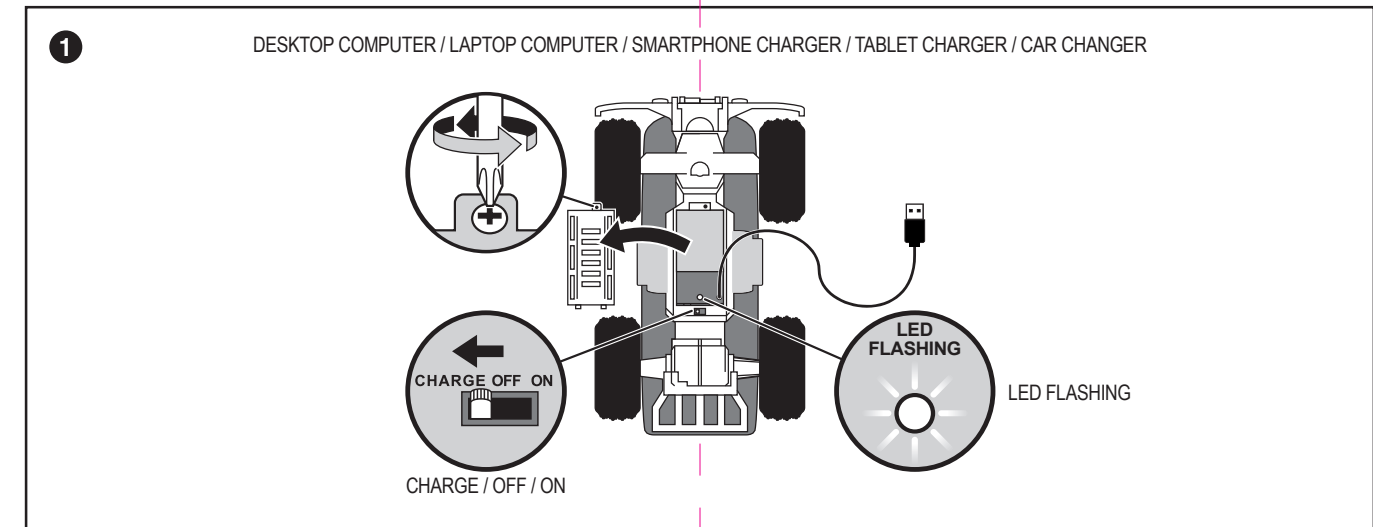

# 第2摺



**CE EZTEC**  
www.eztec.hk

EZ-TEC® IS A REGISTERED TRADEMARK OWNED BY SCIENTIFIC TOYS, LTD.

© 2021 SCIENTIFIC TOYS LTD. 1108, TOWER B,  
14 SCIENCE MUSEUM ROAD, TSIMSHATSUI, HONG KONG.  
PRINTED IN CHINA  
O.I. NO.6606