

OPERATING INSTRUCTIONS



TRY ME UNIT:

Try Me button box is for demonstration purpose only.
Dispose of this unit by detaching the wires connecting to the car before playing.

TRY ME UNIT

BATTERY PACK CARE / CAUTIONS:

1. If battery pack and/or connectors are wet, thoroughly dry before charging.
2. Unplug the battery pack if it is not going to be used for several days.
3. Do not charge battery pack that is hot, wet or shows signs of leakage or corrosion.
4. Do not expose to fire, as explosion may result.
5. Do not disassemble the battery pack.

KEEP PACKAGING AS IT CONTAINS IMPORTANT INFORMATION.

BATTERY INSTALLATION:

BATTERY LOADING

(THE RECHARGEABLE BATTERY PACK IS NOT CHARGED, PLEASE CHARGE IT FOR 2 HOURS PRIOR TO USE)

1. Plug the wall pack battery charger into wall outlet. (See Diagram 1)
2. Click the battery pack into the charger. Make certain the battery pack is secure in charger.
3. To disconnect, push the button on the charger (See Diagram 1) and simultaneously slide battery pack out.
4. You should charge the battery pack for 2 hours the first two times. Then subsequent charges will only require 2 hours.
5. After charging for 2 hours, the battery will be warm. This condition is normal for fully charged batteries.
6. If the speed of the car slows down suddenly, it is time to recharge.
7. After use, the battery pack will be hot! Wait at least 20 minutes until it cools before recharging. Recharging a warm or hot battery pack will greatly shorten the battery life.

ATTENTION PARENTS

IT IS RECOMMENDED THAT THIS TOY AND ALL ACCESSORIES BE PERIODICALLY EXAMINED FOR POTENTIAL HAZARDS AND THAT ANY POTENTIALLY HAZARDOUS PARTS BE REPAIRED OR REPLACED.

CARE

Never drive the vehicle on a wet floor, on sand, grass, carpet, in mud, rain or snow. These can cause damage to the vehicle.

Do not expose the vehicle to extreme temperatures.

To protect the vehicle's wheel mechanisms from lint and hair, do not drive it on carpet. Occasionally wipe the vehicle with a damp cloth remove any dirt/dust from wheels. Do not use harsh chemicals to clean the vehicle.

Modifying or tampering with the vehicle or the transmitter's internal components can cause a malfunction.

HELPFUL HINTS

Running the vehicle continuously for long periods of time generates high levels of heat. Heat causes wear and tear on the motor. When the vehicle's battery pack goes flat, let the vehicle cool at least 10 minutes before installing a newly charged battery pack. This helps keep heat levels down. If the vehicle's motor runs but does not respond to the transmitter, move the transmitter closer to the vehicle and try again. If a CB radio is used nearby, it might interfere with control of the vehicle. If this happens, move the vehicle and transmitter away from the CB radio. The vehicle cannot be operated near devices with transmitters that use the same frequency. Check the packaging to see which frequency your vehicle uses. If the vehicle moves slowly, and a recharged battery pack has been installed, check the wheel mechanisms for lint, thread, hair or dust.

INSERTING BATTERIES

VEHICLE

- A. Turn over the vehicle and push the ON/OFF to "OFF" position. (See Diagram 2)
- B. Open the battery cover. (See Diagram 3)
- C. Insert the 9.6V battery pack into battery compartment. (See Diagram 3)
- D. Replace the battery cover.

TRANSMITTER

1. Unscrew to open the battery lid. Insert 2 x AA batteries. (See Diagram 4)
2. Replace battery cover.

Note: Remove battery after you have finished using your vehicle.

HOW TO PLAY

START TO PLAY

PAIRING TRANSMITTER WITH VEHICLE

1. Turn ON the vehicle (See diagram 5).
2. Install 2 x AA batteries battery in the transmitter, the pairing LED light on the transmitter will flash.
3. If pairing success, the pairing LED light will turn OFF.
4. You must pair the transmitter with the vehicle within 45 seconds, after 45 seconds you must push the control on the transmitter to pair again.
5. You must repeat this exercise again when the transmitter needs to replace new batteries.

OPERATION

1. Operate the vehicle with the transmitter (See Diagram 6).
2. Turn OFF the vehicle and the transmitter after playing and remove all batteries from the transmitter and the car.

FRONT WHEELS STEERING ADJUSTMENT

1. If the vehicle does not run straight forwards, adjust the lever for satisfactory alignment on the underside of the vehicle. (See Diagram 7)
2. If the vehicle runs towards left, turn "Steering Alignment Lever" towards "R".
3. If the vehicle runs towards right, turn "Steering Alignment Lever" towards "L".

Keep packaging as it contains important information.

CAUTION: To prevent battery leakage:

Be sure to insert batteries correctly and always follow the product and battery manufacturers' instructions.
Never mix old and new batteries (replace all batteries at the same time).
Never mix Alkaline, standard (Carbon Zinc) or rechargeable batteries.
Only batteries of the same or equivalent type as recommended are to be used.
Do not use RECHARGEABLE batteries, unless specified.
Non-rechargeable batteries are not to be recharged.
Rechargeable batteries are to be removed from the product before being charged (if removable).

Rechargeable batteries are only to be charged under adult supervision (if removable).
Always remove exhausted or dead batteries from the product.

Remove batteries from product before extended storage.

The supply terminals are not to be short-circuited.

Batteries are to be inserted with correct polarity.

Batteries may explode or leak if misused.

ATTENTION: Battery / Batteries should be installed by an adult only.

ATTENTION: User should remove the battery from the item before disposal.

AA/LR6 or AAA/LR03 Batteries may present a choking hazard - keep away from young children.

Do not disassemble the battery pack (if appropriate).

Battery Chargers

WARNING:

After use, the battery pack will be hot! Wait until it cools before recharging.

Recharging a warm or hot battery (pack) will greatly shorten the battery's life.

Unplug the charger from the electrical outlet if it is not going to be used for a long period of time.

Battery charger must be operated by adults only.

Non-rechargeable batteries are not to be recharged.

Do not charge a battery (pack) that is hot, wet or shows signs of leakage or corrosion.

Do not expose to fire, as this may result in explosion.

Do not short circuit the battery (pack).

Rechargeable batteries must be charged with the recommended battery charger.

The battery charger is to be regularly examined for damage to the cord, plug enclosure and other parts. In the event of such damage, the charger must not be used until it has been repaired or replaced.

The battery charger is not a toy.

Prolonged charging will not improve the battery output, and could eventually damage the battery (pack).

Do not disassemble the battery pack (if appropriate).

Do not disassemble the battery pack (if appropriate).

Do not disassemble the battery pack (if appropriate).

Do not disassemble the battery pack (if appropriate).

Do not disassemble the battery pack (if appropriate).

Do not disassemble the battery pack (if appropriate).

Do not disassemble the battery pack (if appropriate).

Do not disassemble the battery pack (if appropriate).

Do not disassemble the battery pack (if appropriate).

Do not disassemble the battery pack (if appropriate).

Do not disassemble the battery pack (if appropriate).

Do not disassemble the battery pack (if appropriate).

Do not disassemble the battery pack (if appropriate).

Do not disassemble the battery pack (if appropriate).

Do not disassemble the battery pack (if appropriate).

Do not disassemble the battery pack (if appropriate).

Do not disassemble the battery pack (if appropriate).

Do not disassemble the battery pack (if appropriate).

Do not disassemble the battery pack (if appropriate).

Do not disassemble the battery pack (if appropriate).

Do not disassemble the battery pack (if appropriate).

Do not disassemble the battery pack (if appropriate).

Do not disassemble the battery pack (if appropriate).

Do not disassemble the battery pack (if appropriate).

Do not disassemble the battery pack (if appropriate).

Do not disassemble the battery pack (if appropriate).

Do not disassemble the battery pack (if appropriate).

Do not disassemble the battery pack (if appropriate).

Do not disassemble the battery pack (if appropriate).

Do not disassemble the battery pack (if appropriate).

Do not disassemble the battery pack (if appropriate).

Do not disassemble the battery pack (if appropriate).

Do not disassemble the battery pack (if appropriate).

Do not disassemble the battery pack (if appropriate).

Do not disassemble the battery pack (if appropriate).

Do not disassemble the battery pack (if appropriate).

Do not disassemble the battery pack (if appropriate).

Do not disassemble the battery pack (if appropriate).

Do not disassemble the battery pack (if appropriate).

Do not disassemble the battery pack (if appropriate).

Do not disassemble the battery pack (if appropriate).

Do not disassemble the battery pack (if appropriate).

Do not disassemble the battery pack (if appropriate).

Do not disassemble the battery pack (if appropriate).

Do not disassemble the battery pack (if appropriate).

Do not disassemble the battery pack (if appropriate).

Do not disassemble the battery pack (if appropriate).

Do not disassemble the battery pack (if appropriate).

Do not disassemble the battery pack (if appropriate).

Do not disassemble the battery pack (if appropriate).

Do not disassemble the battery pack (if appropriate).

Do not disassemble the battery pack (if appropriate).

Do not disassemble the battery pack (if appropriate).

Do not disassemble the battery pack (if appropriate).

Do not disassemble the battery pack (if appropriate).

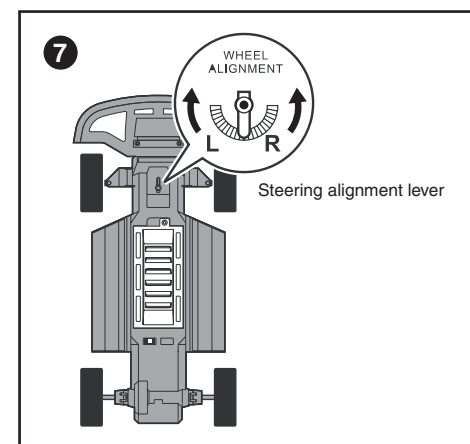
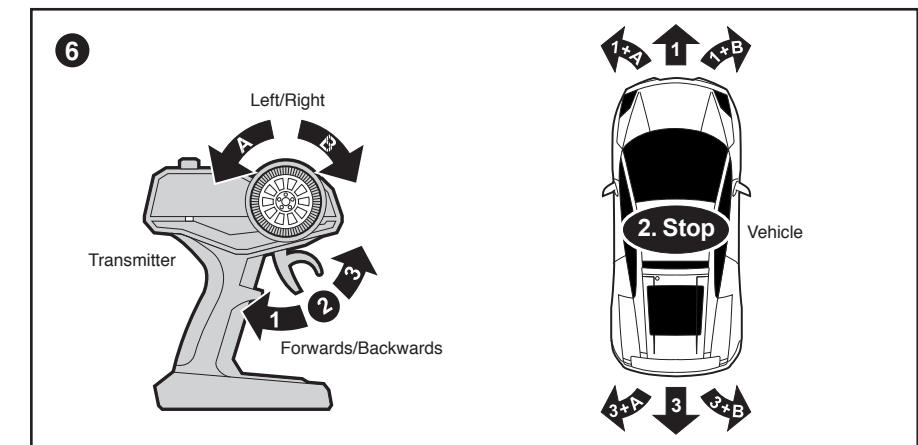
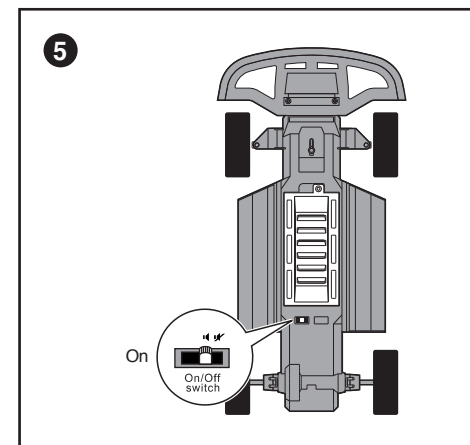
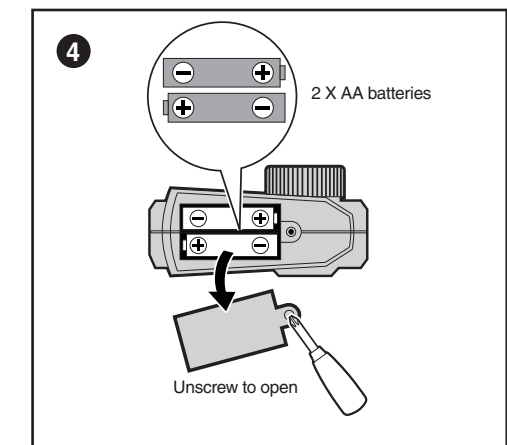
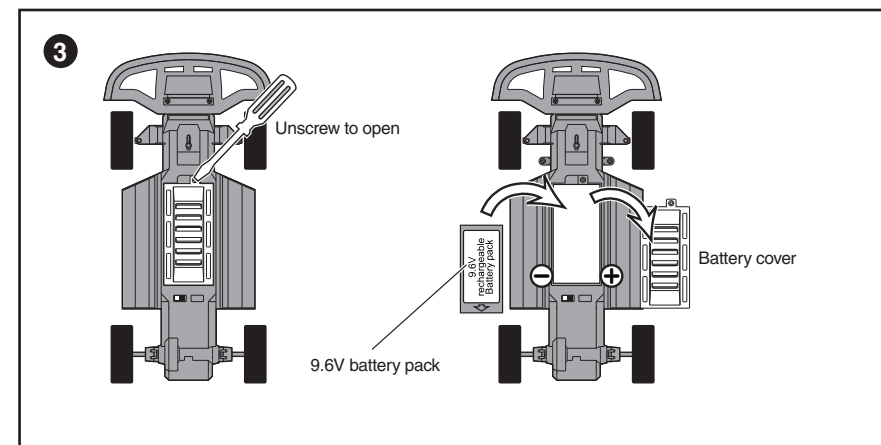
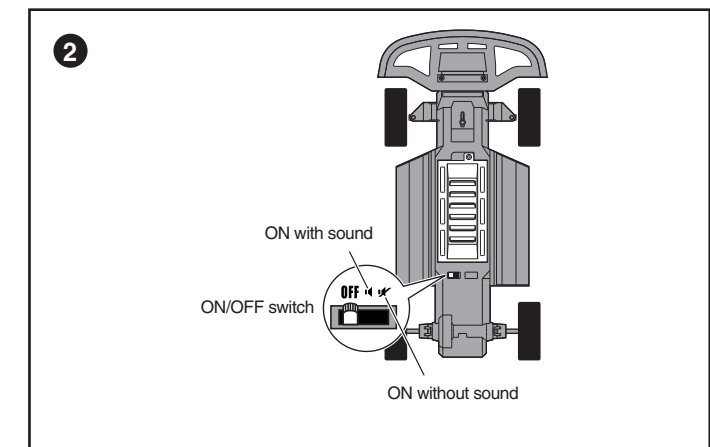
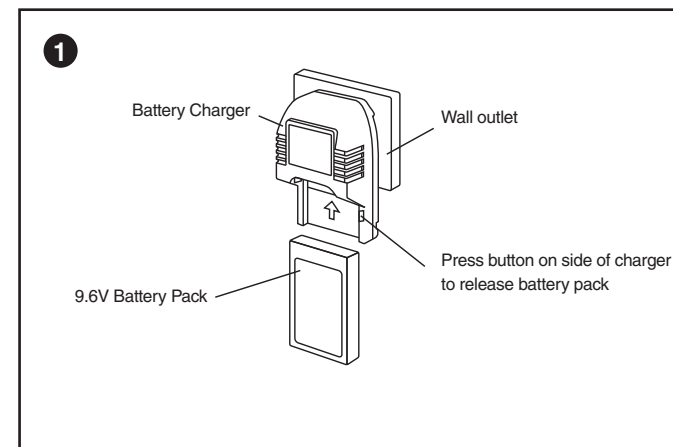

EZTEC[®]
www.eztec.hk

EZ-TEC[®] IS A REGISTERED TRADEMARK OWNED BY SCIENTIFIC TOYS, LTD.

© 2018 SCIENTIFIC TOYS LTD. 1108, TOWER B,
14 SCIENCE MUSEUM ROAD, TSMHATSUI, HONG KONG.
PRINTED IN CHINA
O.I. NO.6379

SIZE: 210MM X 297MM

PN#65-6379-000-0100