

**Note:**  
DO NOT INSERT CR 79-86  
Need to be Added to  
the BOM on AMAP

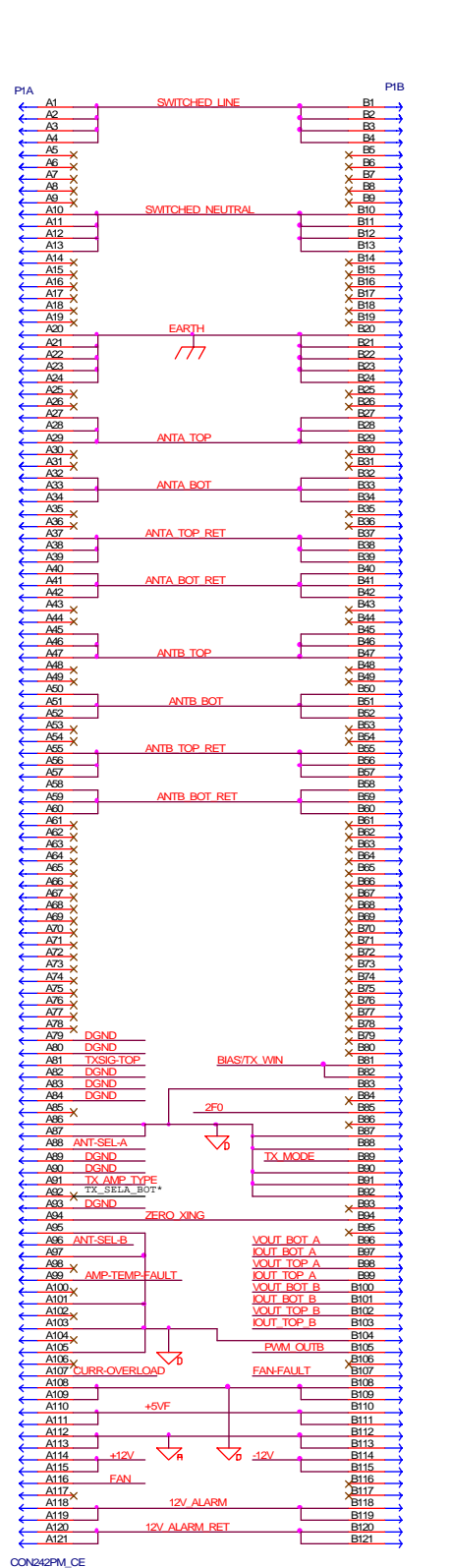

NOTE:  
\* THIS SIGNAL USED ON THE LPA BOARD

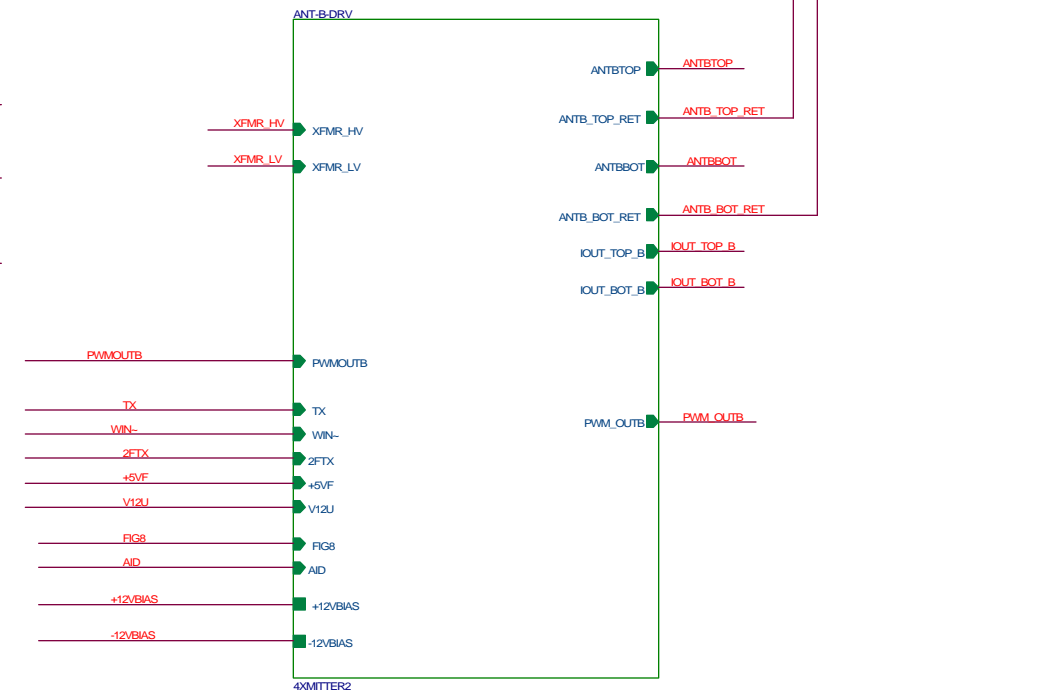
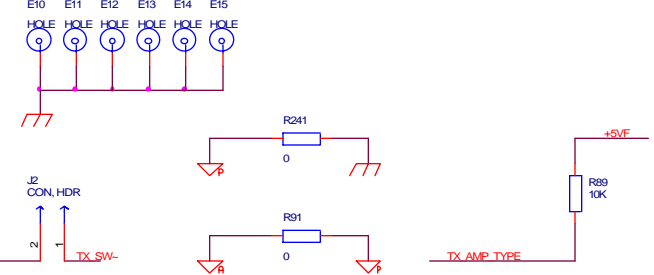
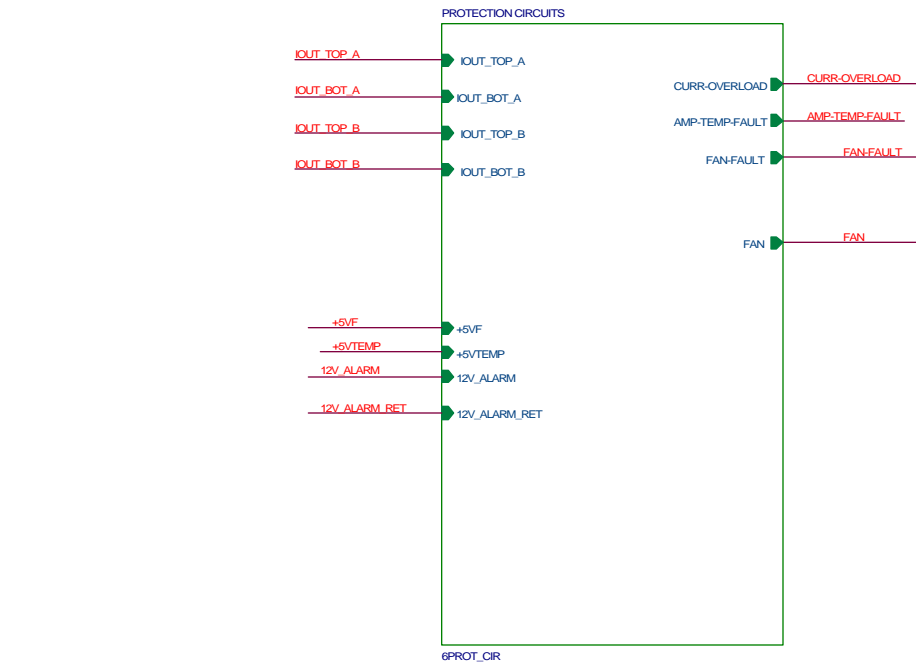
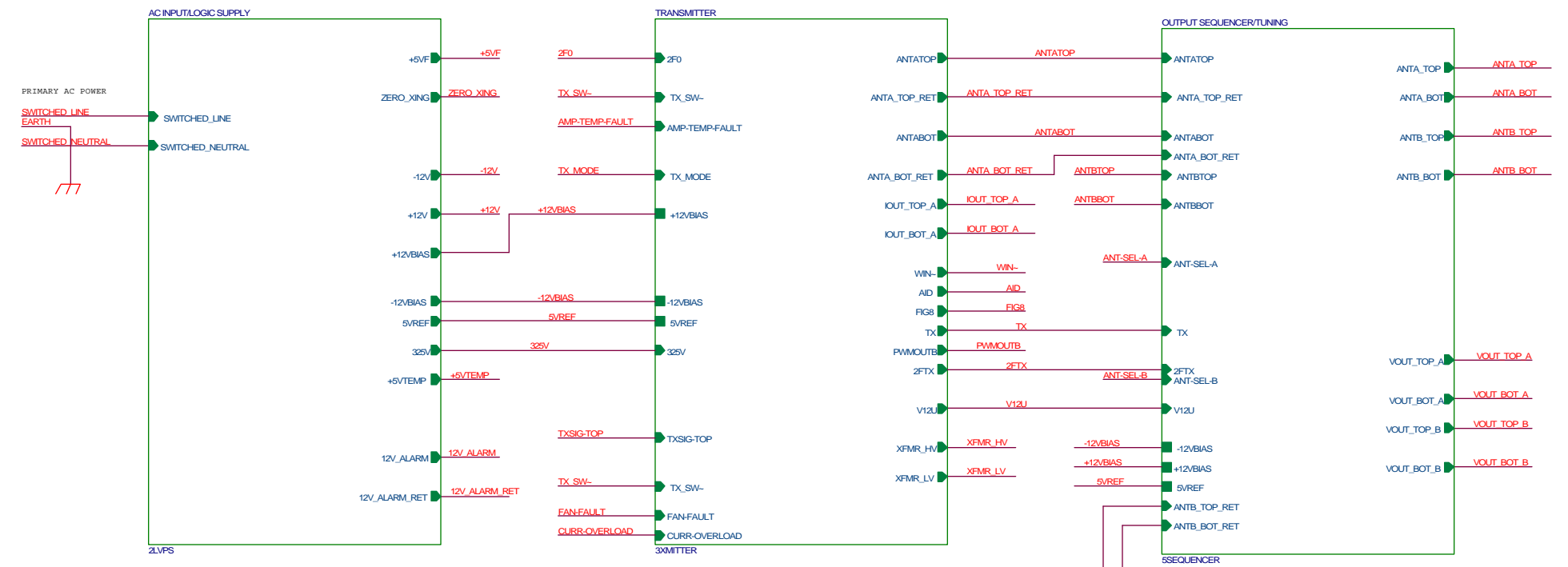

C107	CR40	R170	Q48	U12
J7	P11			
	HIGHEST	REF DES.	USED	

Notes:  
1. UNLESS OTHERWISE SPECIFIED:  
ALL RESISTOR VALUES ARE IN OHMS-5%,  
RESISTOR POWER RATINGS ARE 1/4W.  
CAPACITOR VALUES ARE IN MICRO FARAD,.

APPROVALS	DATE
Drawn (NAME)	(DATE)
Checked (NAME)	(DATE)
Engr (NAME)	(DATE)
Appd (NAME)	(DATE)
Release (NAME)	(DATE)

A	(PCNH)	REL PER ER	(DATE)	XXX	XXX
LTR	PCNNO.	DESCRIPTION	DATE	BY	APPD
<b>Sensormatic Electronics Corp.</b>					
951 YAMATO ROAD BOCA RATON, FLORIDA 33431					
Title <b>SCHEMATIC, ADS216 XMTR/PWR SUPPLY NE</b>					
Size	Document Number			Rev	
C	S0301-1508-01			3C	
Date:	Tuesday, February 22, 2000	Sheet	1	of	6