

Scan Thru Platform

Theory of Operation

Preliminary
12/09/98

Overview - The ScanThru Platform (STP) utilizes Label detection to trigger the Deactivation sequence with the power supply and interface circuits supporting these two main functions. The STP consists of a separate power pack and antenna assemblies. Figure 1 shows a block diagram of this system. The Power pack consists of one large circuit board and a capacitor tuning board. The antenna consists of two windings which are used for transmit, receive and deactivation. The system board can be divided into several sections; power supply, controller, transmitter, receiver, high voltage control, charge, deactivation and interface sections. The following describes each of these sections in more detail:

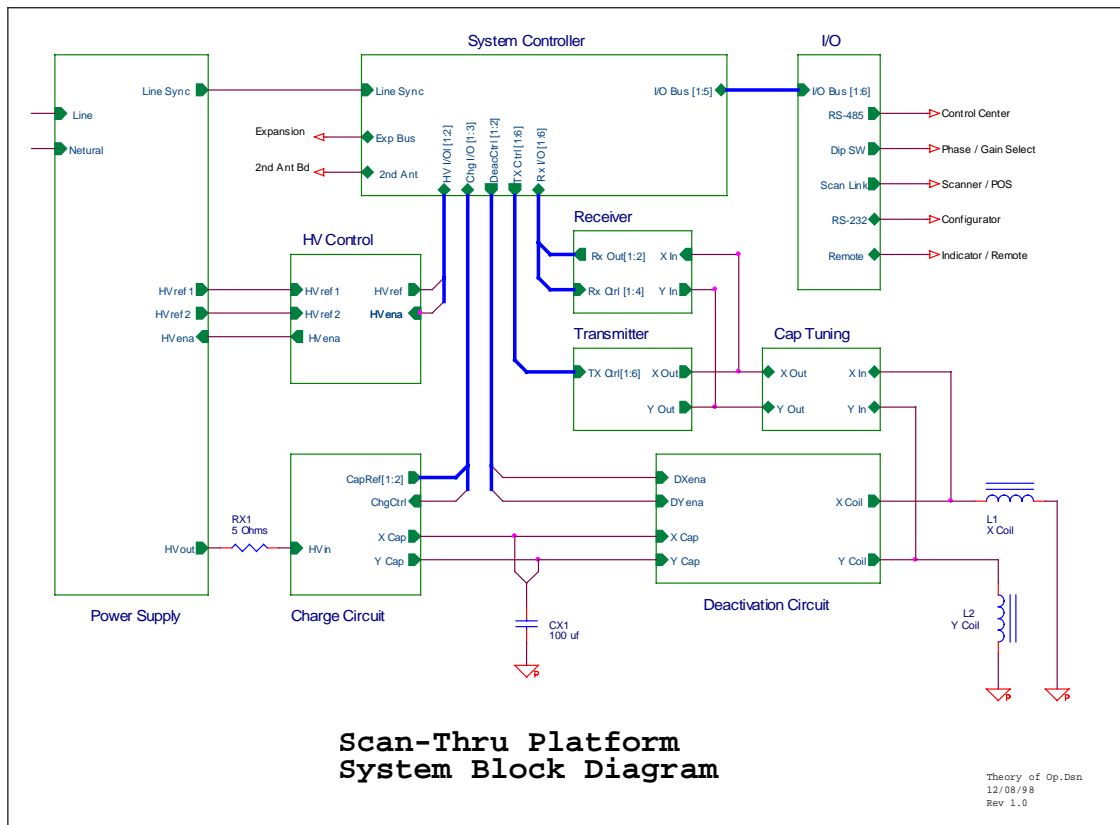

1. **Power Supply** – The purpose of the power supply is to generate the low voltage bias supplies required by the internal circuitry and to generate the high voltage needed for deactivation as well as to provide a zero crossing output to the microprocessor. The power supply actually consist of two separate switch mode power supplies; one for the bias and one for the high voltage. Both supplies are connected off line and utilize output transformers to achieve isolation. The bias supply is a standard fly-back converter operating at 37Khz. This supply has three outputs; 25 Vdc, +12 Vdc and –12 Vdc. Post regulation utilizing a three terminal regulator is used to generate the +5 Vdc logic supply from the +12V output. The high voltage supply is also a fly-back converter that has been modified to achieve good power factor correction utilizing a simple on-off control method. The zero crossing circuit provides a 30us pulse at the rising edge of the zero crossing of the AC mains. This signal is used to provide synchronization of the Ultra*Max transmit and receive functions.
2. **Controller** – The purpose of the controller section is to monitor and control all system operation. The control section consists of a microprocessor, memory, a CPLD (Complex Programmable Logic

Device) and associated logic used to “glue” these functions together. The microprocessor, a Motorola 68HC12 device contains internal memory, timers and analog to digital converters. A flash EEPROM is used to store the program executable code and static ram is used for buffers and variable storage. The CPLD is used to generate the various system clocks and to multiplex the microprocessor timer outputs to each of the other sections. The microprocessor controls virtually all of the critical system functions including HV set point control, Charge and Deactivation switch timing, Transmitter power and timing and receiver operation.

3. **Transmitter** - The purpose of the transmitter is to generate the transmit field used to excite the Ultra*Max label. The timing and amplitude of the transmitter is controlled by the microprocessor. A separate 116kHz signal is used by this section to generate the 58kHz transmit frequency. There are separate outputs for the x and the y antenna windings. A standard half bridge driver is used to drive the MosFet output drivers. The output of each transmitter is series resonated at 58kHz using capacitors on the Cap tuning board which are matched to the inductance of each output winding. These capacitors also are used to achieve isolation between the high voltage output and the low voltage transmitter circuits.
4. **Receiver** - The purpose of the receiver is to detect the presence of the Ultra*Max label. The input of the receiver is capacity coupled to the transmitter output. The receiver consists of a RF front end section and a base band output section. The input section consists of an input muxiplexer, low noise amplifiers, blanking components, a programmable gain stage, a band pass filter stage which feeds an synchronous demodulator or mixer. The function of the front end is to amplify and filter the very small tag signal. This signal 58kHz label signal is mixed with a 58kHz carrier. The output frequency of the mixer consists of the sum and differences of the label frequency and the carrier frequency. If the label is at exactly 58kHz the output of the mixer will be DC and 116kHz. The amplitude is a function of the label amplitude and the phase difference between the label signal and the carrier signal. Because the phase relationship between the label and carrier is dependent upon label position and orientation to the receive antenna, two separate mixers are used with the separate carriers which are phased 90° apart. The output of each mixer is then low passed filtered at approximately 500 Hz to eliminate the high frequency products and to provide rejection of out of band noise. This signal is then full wave rectified to achieve compatibility with the microprocessor single ended A/D converter.
5. **HV Control** – The purpose of the high voltage control circuit is to provide set point and over voltage protection functions for the high voltage power supply. The inputs to this circuit consist of an enable signal from the microprocessor and two reference feedback signals from the high voltage output. One reference signal is utilized as an over voltage shutdown while the second reference is used for set point control. This signal is also buffered and used as a microprocessor input allowing the microprocessor to control the voltage below the maximum hardware set point voltage. This function is used to achieve magnetic media safe operation since the antenna surface field level is a direct function of the operating voltage.
6. **Charge** – The purpose of the charge circuit is to provide a means to charge the resonating capacitor while providing impedance isolation between the low impedance high voltage supply output and the resonating capacitor. This circuit consists of two identical sections allowing the use of separate capacitor banks for the x and y antenna coils if necessary in future antenna designs. Each circuit is comprised of a half bridge driver circuit (identical to the one used in the transmitter section) that drives a transformer. The purpose of this transformer is to provide safety isolation and to allow the charge switch to be referenced to the output voltage that varies with the resonating capacitor voltage. The output of this transformer is rectified and used to generate the gate voltage to the IGBT (Insulated gate bipolar transistor) switch. An additional transistor circuit is utilized to provide a fast turn off of the IGBT and to ensure that the part remains off. The charge current is limited by a single chassis mounted 5 ohm resistor.
7. **Deactivation** - The purpose of the deactivation circuit is to switch the resonating cap and the antenna winding together to form a parallel resonant circuit with a resonating frequency of approximately 500Hz. This section consists of two identical circuits for the x and y antenna windings. Each switch

consist of anti-parallel SCR's (Silicon Controlled Rectifiers) forming an AC switch. These switches are controlled by the microprocessor utilizing a opto-triac driver which triggers the SCR's on and provides safety isolation.

- 8. Interface** - The purpose of the interface circuit is to provide an interface from the microprocessor and external devices. This section contains an RS-485 port, RS-232 port, Scan Link port, Indicator output and a dip switch input. The RS-485 output is used to communicate on a two-wire bus with a host controller allowing remote diagnostics and control. The RS-232 port is used to provide communication between the STP and a laptop configurator. The Scan Link port provides an isolated output and two isolated inputs that can be used to interface to certain scanners and other POS equipment. The Interface port contains LED and audio outputs and a key switch input when used with the Power Pad indicator board or the Rapid Pad Remote Alarm Module. A dip switch input allows the installer to set the Transmitter phase (A, B, C or 90 Hz), to compensate for reversed AC mains wiring and to switch the default receiver gain setting.
- 9. Antenna** – The purpose of the antenna is to generate the transmitter field, receive the labels signal and to generate the deactivation field. The antenna consists of two separate windings. Each winding is time division multiplexed for each of these functions. These windings are wound orthogonal on a press powered iron core. The windings are orthogonal to ensure that performance is maintained regardless of label orientation.