



Test report no. : 69376-5

Item tested : BeoCom 4 US Handset

Type of equipment : Isochronous UPCS Device

FCC ID : BV5BEOCOM4HS

Client : Bang & Olufsen A/S

FCC Part 15, subpart D
Isochronous UPCS Device
1920 - 1930 MHz

Industry Canada RSS-213, Issue 2
2 GHz Licence-exempt Personal
Communications Service Devices
(LE-PCS)

28 September 2006

Authorized by : *Egil Hauger*

Egil Hauger
Technical Verificator



CONTENTS

1	GENERAL INFORMATION.....	3
1.1	Tested by.....	3
1.2	Client Information.....	3
1.3	Manufacturer (if other than client).....	3
2	TEST INFORMATION.....	4
2.1	Tested Item.....	4
2.2	Test Environment.....	5
2.3	Test Period.....	5
2.4	Test Engineer(s).....	5
2.5	Test Equipment.....	5
2.6	Other Comments.....	5
3	TEST REPORT SUMMARY.....	6
3.1	General.....	6
3.2	Test Summary.....	7
4	TEST RESULTS.....	8
4.1	Power-line Conducted Emissions.....	8
4.2	Coordination with fixed microwave.....	10
4.3	Digital Modulation Techniques.....	10
4.4	Labelling Requirements.....	10
4.5	Antenna Requirement.....	11
4.6	Channel Frequencies.....	11
4.7	Automatic Discontinuation of Transmission.....	12
4.8	Peak Power Output.....	13
4.9	Emission Bandwidth B	15
4.10	Power Spectral Density.....	17
4.11	In-Band Unwanted Emissions, Conducted.....	19
4.12	Out-of-band Emissions, Conducted.....	21
4.13	Carrier Frequency Stability.....	23
4.14	Frame Repetition Stability.....	24
4.15	Frame Period and Jitter.....	24
4.16	Monitoring Threshold, Least Interfered Channel.....	27
4.17	Threshold Monitoring Bandwidth.....	29
4.18	Reaction Time and Monitoring Interval.....	30
4.19	Time and Spectrum Window Access Procedure.....	32
4.20	Acknowledgements and Transmission Duration.....	33
4.21	Dual Access Criteria Check.....	35
4.22	Alternative Monitoring Interval.....	35
4.23	Duty Cycle Correction Factor Calculation.....	39
4.24	Spurious Emissions (Radiated).....	40
5	TEST SETUPS.....	52
5.1	Frequency Measurements.....	52
5.2	Timing Measurements.....	52
5.3	Conducted Emission Tests.....	52
5.4	Radiated Emission Tests.....	53
5.5	Powerline Conducted Tests.....	53
5.6	Monitoring Tests.....	54
6	TEST EQUIPMENT USED.....	55

1 GENERAL INFORMATION

1.1 Testhouse Info

Name : Nemko Comlab
Address : Gåsevikveien 8, Box 96
N-2027 Kjeller, NORWAY
Telephone : +47 64 84 57 00
Fax : +47 64 84 57 05
E-mail: post@comlab.no
FCC test firm registration # : 994405
IC OATS registration # : 4443
Total Number of Pages: 55

1.2 Client Information

Name : Bang & Olufsen Telecom A/S
Address : Peter Bangs Vej 15, 7600 Struer, Denmark
Telephone : +45 9684 1085

Contact:

Name : jens Aksel Thomsen
E-mail : jmt@bang-olufsen.dk

1.3 Manufacturer (if other than client)

Name : Bang & Olufsen a/s
Address : Peter Bangs Vej 15, 7600 Struer, Denmark
and:
Name : Bang & Olufsen S.R.O.
Address : Koprivnice 742 21, Czech Republic

2 Test Information

2.1 Tested Item

Name :	Bang & Olufsen
FCC ID :	BV5BEOCOM4HS
Industry Canada ID :	3775A-BEOCOM4H
Model/version :	BeoCom4 US
Serial number :	Conducted sample: Comlab 3 Radiated Sample: Base: s.n.:19347804
Hardware identity and/or version:	G
Software identity and/or version :	2.1
Frequency Range :	1921.536 – 1928.448 MHz
Tunable Bands :	1
Number of Channels :	5 RF Channels, 5x12 = 60 TDMA Duplex Channels
Type of Modulation :	GFSK (Gaussian Frequency Shift Keying)
User Frequency Adjustment :	None
Rated Output Power :	110 mW Peak Power; 4.6 mW Time Averaged Power
Type of Power Supply :	NiMH Rechargeable Battery
Antenna Connector :	None
Antenna Diversity Supported :	No
Desktop Charger :	The charger is integrated in the base station

Description of Tested Device(s)

The tested equipment is a DECT handset which complies with ETSI EN 300 175. The frequencies have been reprogrammed and the output power reduced to comply with the FCC requirements to an Isochronous UPCS device after FCC Part 15D.

The EUT is an initiating device as described in ANSI C63.17 and is designed to operate together with a DECT fixed part (i.e. a base station), which is then the responding device.

Exposure Evaluation

The EUT is a portable device and is designed to be held to ear when used. A test reports with the measured SAR values is submitted with the application. The SAR values are also included in the user manual.

The EUT is exempted from RF Exposure Evaluation to Industry Canada SAR requirements since the output power is below the limit in RSS-102 Issue 2, clause 2.5.1 for General Public Use.

2.2 Test Environment

Temperature:	22 – 24 °C
Relative humidity:	30 – 50 %
Normal test voltage:	2.5 V DC

The values are the limit registered during the test period.

2.3 Test Period

Item received date:	2006-07-11
Test period :	from 2006-07-12 to 2006-09-28

2.4 Test Engineers

Frode Sveinsen / Tore Løvlien

2.5 Test Equipment

See list of test equipment in clause 6.

2.6 Other Comments

The Monitoring and Time and Spectrum Window Access tests were performed with Test Set-Up 6 (Ref. clause 5). A clock signal from the companion device was used to synchronize the Pulse Pattern Generator and the Spectrum Analyzer to the start of the DECT time window. The EUT was limited by administrative commands to operate on only two frequency carriers. For the tests where the EUT was required to operate on only one frequency carrier, one carrier was blocked by applying a CW interfering signal from RF Generator 3. The Pulse Pattern Generator was used to apply time synchronized interference to time windows where this was required.

Since the EUT was programmed to operate on only two RF carriers, it was only necessary with two RF generators for the monitoring tests, however a third generator was applied for the tests that required specific time slots to be blocked.

All tests except the Radiated Spurious Emissions, Radiated Power and the Power line conducted emissions tests were performed in conducted mode with a temporary antenna connector.

3 TEST REPORT SUMMARY

3.1 General

Manufacturer: Bang & Olufsen
Model No.: BeoCom 4 US
Serial No.: /

All measurements are traceable to national standards.

The tests were conducted on a sample of the equipment for the purpose of demonstrating compliance with FCC CFR47 Part 15, paragraph 15.323 for Isochronous UPCS Devices and Industry Canada RSS-213 Issue 2.

The conducted test methods have been in accordance with ANSI C63.17-2006 Draft 3.5 where applicable.

Radiated tests were conducted in accordance with ANSI C63.4-2003. Radiated emissions are made in a 10m semi-anechoic chamber. A description of the test facility is on file with the FCC and Industry Canada.

- | | |
|---|---|
| <input checked="" type="checkbox"/> New Submission | <input checked="" type="checkbox"/> Production Unit |
| <input type="checkbox"/> Class II Permissive Change | <input type="checkbox"/> Pre-production Unit |
| PUE Equipment Code | <input type="checkbox"/> Family Listing |

THIS TEST REPORT RELATES ONLY TO THE ITEM (S) TESTED.
Deviations from, additions to, or exclusions from the test specifications are described in "Summary of Test Data".



TEST REPORT NO: 69376-5

TESTED BY : 
Frode Sveinsen, Chief Engineer

DATE: 28 September 2006

Nemko Comlab authorizes the above named company to reproduce this report provided it is reproduced in its entirety and for use by the company's employees only. Any reproduction of parts of this report requires approval in writing from Nemko Comlab.

Any use which a third party makes of this report, or any reliance on or decisions to be made based on it, are the responsibility of such third parties. Nemko Comlab accepts no responsibility for damages suffered by any third party as a result of decisions made or actions based on this report.

3.2 Test Summary

Name of test	FCC CFR 47 Paragraph #	IC RSS-213 Paragraph #	Verdict
Coordination with fixed microwave	15.307(b)	-	Complies
Digital Modulation Techniques	15.319(b)	6.1	Complies
Labelling requirements	15.19(a)(3)	RSS-GEN 5.2	Complies
Antenna Requirement	15.317, 15.203	4.1(e)	Complies
Power Line Conducted Emissions	15.207(a)	6.3	Complies
Emission Bandwidth	15.323(a)	6.4	Complies
In-band emissions	15.323(d)	6.7.2	Complies
Out-of-band emissions	15.323(d)	6.7.1	Complies
Peak transmit Power	15.319(c), 15.31(e)	6.5	Complies
Power Spectral Density	15.319(d)	4.3.2.1	Complies
Automatic discontinuation of transmission	15.319(f)	4.3.4	Complies
Carrier frequency stability	15.323(f)	6.2	Complies
Frame repetition stability	15.323(e)	4.3.4(c)	Complies
Frame period and jitter	15.323(e)	4.3.4(c)	Complies
Monitoring threshold, Least interfered channel	15.323(c)(2);(5); (9)	4.3.4(b)	Complies
Monitoring of intended transmit window and maximum reaction time	15.323(c)(1)	4.3.4	Complies
Threshold monitoring bandwidth	15.323(c)(7)	4.3.4	Complies
Reaction time and monitoring interval	15.323(c)(1);(5); (7)	4.3.4	Complies
Access criteria test interval	15.323(c)(4);(6)	4.3.4	N/A ¹
Access Criteria functional test	15.323(c)(4);(6)	4.3.4	N/A ¹
Acknowledgements	15.323(c)(4)	4.3.4	Complies
Transmission duration	15.323(c)(3)	4.3.4	Complies
Dual access criteria	15.323(c)(10)	4.3.4	Complies
Alternative monitoring interval	15.323(c)(10);(11)	4.3.4	N/A ²
Spurious Emissions (Antenna Conducted)	15.323(d)	6.7.1	Complies ³
Spurious Emissions (Radiated)	15.209	4.3.3	Complies
Receiver Spurious Emissions	/	6.8	Complies

¹ Only applies for equipment that transmits unacknowledged control and signalling information.

² The client declares that the tested equipment does not implement this provision.

³ The tested equipment has integral antennas only.

4 TEST RESULTS

4.1 Power Line Conducted Emissions

Para. No.: 15.207 (a)

Test Performed By: Tore Løvlien	Date of Test: 26 July 2006
---------------------------------	----------------------------

Measurement procedure: ANSI C63.4-2003 using 50 μ H/50 ohms LISN.

Test Results: Complies

Measurement Data: See attached graph, (Peak detector).

Highest measured value (L1 and N):

All values are below the limit when measuring with Peak Detector.

Frequency	Detector	Measured value	Limit	Margin
KHz	Peak/QP/AV	dB μ V	dB μ V	dB
/	QP	/	/	/
/	AV	/	/	/



Date 26.Jul.'06 Time 14:53:03
 Ref.Lvl
 100.00 dB μ V

Res.Bw 9 kHz[imp]
 TG.Lvl off
 Scan.Stp 4.500 kHz

T1: PK+ T3:
 T2: PK+ T4:
 RF.Att 10 dB
 Unit [dB μ V]

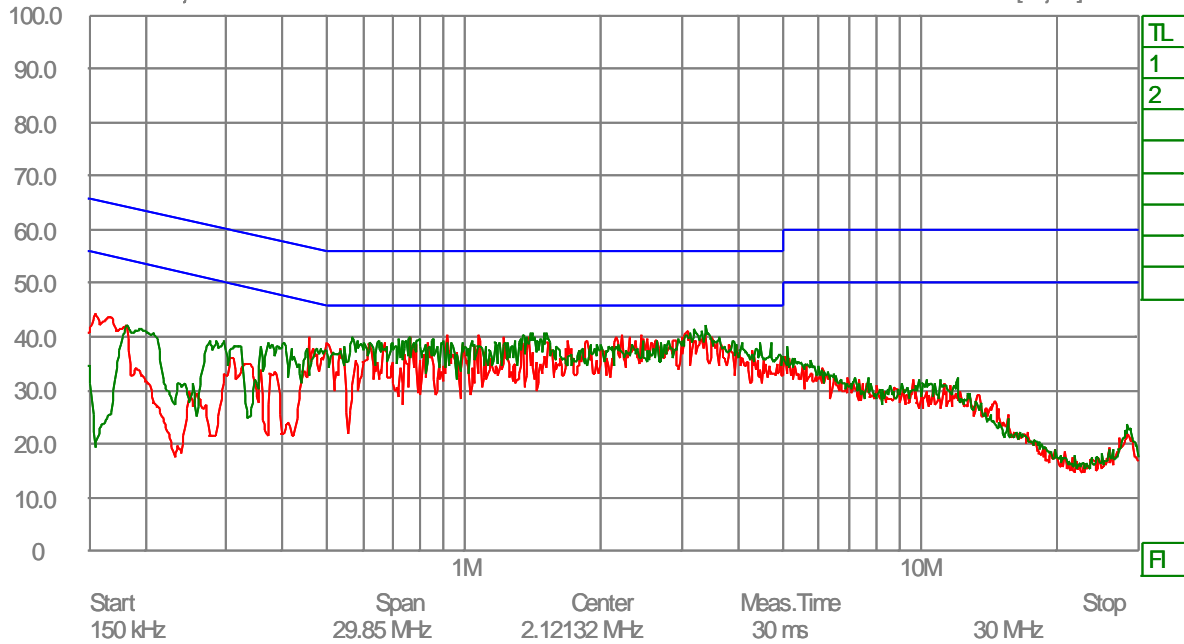

B&O BeoCom4 US
 AC Mains 115V AC charging mode

Power Line Conducted Emissions, Phase L1 and N, Handset Charging, Peak Detector

4.2 Coordination with fixed microwave

The affidavit from UTAM, Inc. is included in the documentation supplied by the applicant:

Yes

No

Requirement, FCC 15.307 (b):

Each application for certification of equipment operating under the provisions of this Subpart must be accompanied by an affidavit from UTAM, Inc. certifying that the applicant is a participating member of UTAM, Inc. In the event a grantee fails to fulfil the obligations attendant to participation in UTAM, Inc., the Commission may invoke administrative sanctions as necessary to preclude continued marketing and installation of devices covered by the grant of certification, including but not limited to revoking certification.

4.3 Digital Modulation Techniques

The tested equipment is based on DECT technology described in the ETSI standard EN 300175, the only difference is that the channel allocation is modified to operate in the 1920-1930 MHz band.

The EUT used Multi Carrier / Time Division Multiple Access / Time Division Duplex and Digital GFSK modulation.

For further details see the operational description provided by the applicant.

Requirement, FCC 15.319(b):

All transmissions must use only digital modulation techniques.

4.4 Labelling Requirements

See separate documents showing the label design and the placement of the label on the EUT.

Requirements FCC 15.19

The FCC Identifier shall be displayed on the label, and the device(s) shall bear the following statement in a conspicuous location on the device or in the user manual if the device is too small:

This device complies with Part 15 of the FCC Rules. Operation is subject to the following two conditions: (1) this device may not cause harmful interference, and (2) this device must accept any interference received, including interference that may cause undesired operation.

The label itself shall be of a permanent type, not a paper label, and shall last the lifetime of the equipment.

4.5 Antenna Requirement

Does the EUT have detachable antenna?

Yes No

If detachable, is the antenna connector non-standard?

Yes No

The tested equipment has only integral antennas. The conducted tests were performed on a sample with a temporary antenna connector.

Requirement: FCC 15.203, 15.204, 15.317.

4.6 Channel Frequencies

UPCS CHANNEL	FREQUENCY (MHz)
Upper Band Edge	1930.000
0 (Highest)	1928.448
1	1926.720
2	1924.992
3	1923.264
4 (Lowest)	1921.536
Lower Band Edge	1920.000

Requirement: FCC 15.303 (d), (g)

Within 1920 -1930 MHz band for isochronous devices.

4.7 Automatic Discontinuation of Transmission

The EUT transmits Control and Signalling Information?	<input type="checkbox"/> YES	<input checked="" type="checkbox"/> NO
TYPE OF EUT :	<input checked="" type="checkbox"/> INITIATING DEVICE	<input type="checkbox"/> RESPONDING DEVICE

The following tests simulate the reaction of the EUT in case of either absence of information to transmit or operational failure after a connection with the companion device is established.

Number	Test	EUT Reaction	Verdict
1	Power removed from the EUT	C	Pass
2	EUT Switch Off	C	Pass
3	Hook-On by companion device	N/A	Pass
4	Hook-On by EUT	C	Pass
5	Power Removed from Companion Device	A	Pass
6	Companion Device Switch Off	N/A	Pass

- A - Connection breakdown, Cease of all transmissions
- B - Connection breakdown, EUT transmits control and signalling information
- C - Connection breakdown, Companion Device transmits control and signalling information
- N/A - Not Applicable (Hook-On and Power-Off of the companion device is not possible)

Requirements, FCC 15.319(f)

The device shall automatically discontinue transmission in case of either absence of information to transmit or operational failure. These provisions are not intended to preclude transmission of control and signalling information or use of repetitive codes used by certain digital technologies to complete frame or burst intervals.

4.8 Peak Power Output

Test Method:

ANSI C63.17, clause 6.1.2.

Test Results: Complies

Measurement Data:

Maximum Conducted Output Power

Channel No.	Frequency (MHz)	Maximum Conducted Output Power (dBm)	Maximum Radiated Output Power (dBm)	Maximum Antenna Gain (dBi)
4	1921.536	20.4	19.4	-1.0
0	1928.448	20.2	19.2	-1.0

The EIRP is calculated from measured field strength by the formula in DA00-705.

Limit:

Conducted: $100 \mu\text{W} \times \text{SQRT}(B) = 113 \text{ mW} = 20.5 \text{ dBm}$, where B is measured emission bandwidth in Hz

The antenna gain is below 3 dBi, no reduction in transmit power is necessary.

Rated antenna gain: 0 dBi

Requirements, FCC 15.319(c)(f)

Peak transmit power shall not exceed 100 microwatts multiplied by the square root of the emission bandwidth in hertz.

The peak transmit power shall be reduced by the amount in decibels that the maximum directional gain of the antenna exceeds 3 dBi.

Conducted Peak Output Power

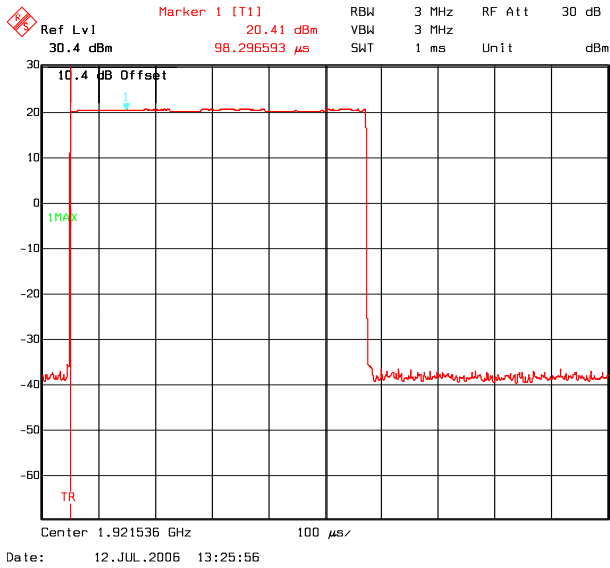

Lower Channel

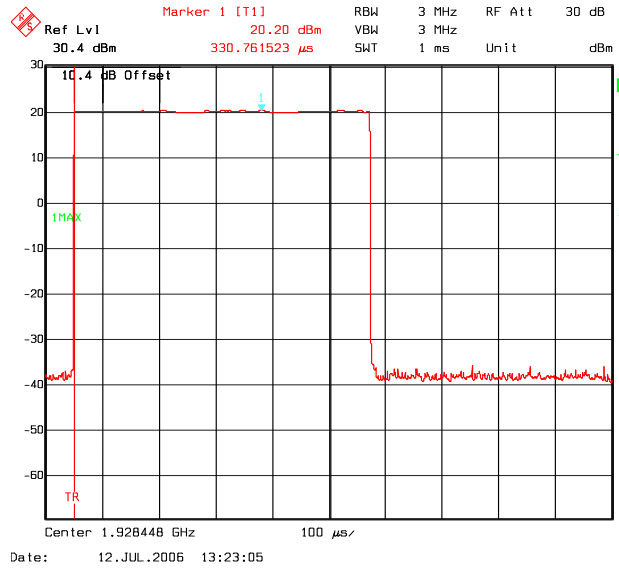

Upper Channel

Radiated Peak Output Power

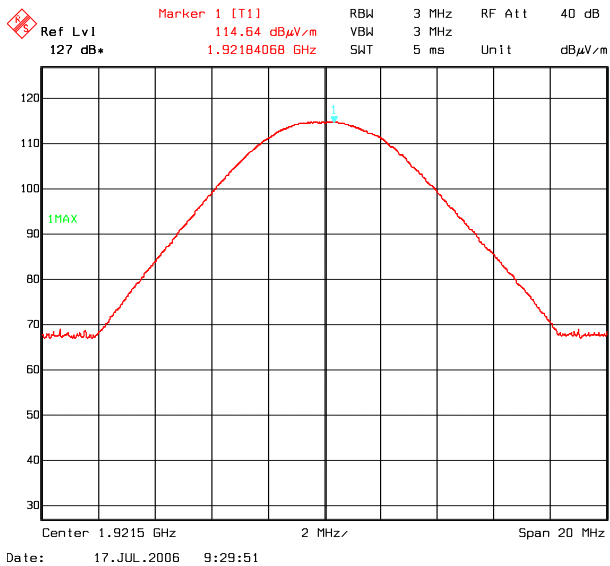

Lower Channel (Max: EUT V, VP)

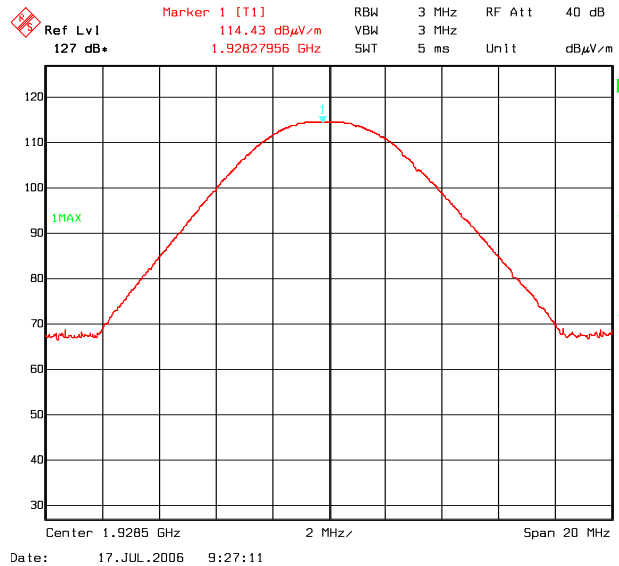

Upper Channel (Max: EUT V, VP)

4.9 Emission Bandwidth *B*

Test Method:

ANSI C63.17 D3.5, clause 6.1.3.

Test Results: Complies

Measurement Data:

Channel No.	Frequency (MHz)	26 dB Bandwidth <i>B</i> (kHz)
4	1921.536	1282.6
2	1924.992	1282.6
0	1928.448	1282.6

Channel No.	Frequency (MHz)	6 dB Bandwidth (kHz)
4	1921.536	881.8
0	1928.448	901.8

Channel No.	Frequency (MHz)	12 dB Bandwidth (kHz)
4	1921.536	1202.4
0	1928.448	1202.4

Requirements, FCC 15.323(a)

The 26 dB Bandwidth *B* shall be larger than 50 kHz and less than 2.5 MHz.

No requirements for 6 and 12 dB Bandwidth, these values are only used for testing Monitoring Bandwidth if the Simple Compliance test fails (ANSI C63.17 D3.5 clause 7.4).

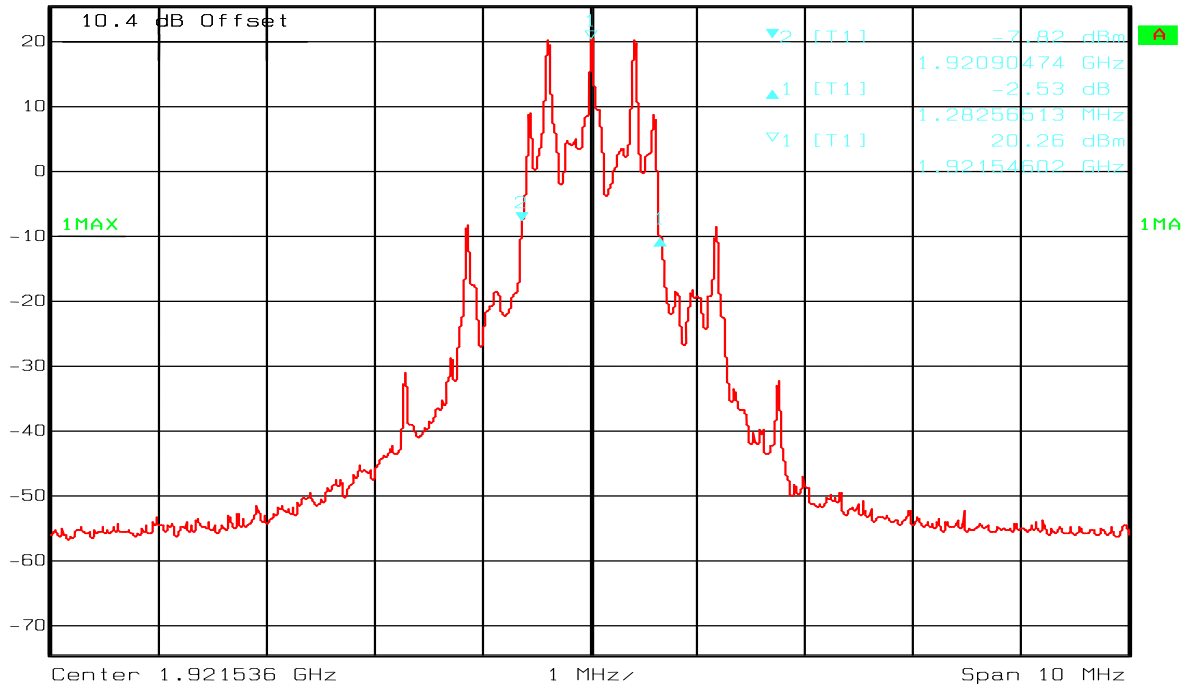

 Delta 1 [T1] RBW 20 kHz RF Att 30 dB
 Ref Lvl -2.53 dB VBW 100 kHz
 25.4 dBm 1.28256513 MHz SWT 64 ms Unit dBm



Date: 12.JUL.2006 13:37:53

Emission Bandwidth B, Lower Channel

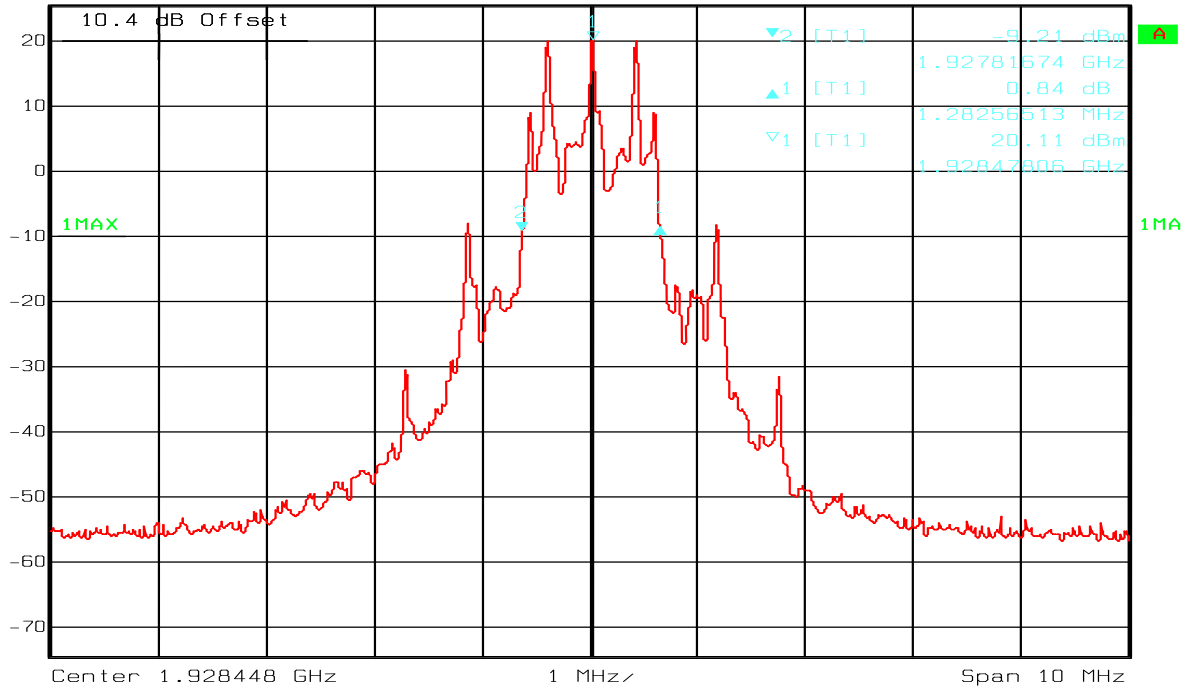
 Delta 1 [T1] RBW 20 kHz RF Att 30 dB
 Ref Lvl 0.84 dB VBW 100 kHz
 25.4 dBm 1.28256513 MHz SWT 64 ms Unit dBm



Date: 12.JUL.2006 13:47:33

Emission Bandwidth B, Upper Channel

4.10 Power Spectral Density

Test Method:

ANSI C63.17, clause 6.1.5.

Test Results: Complies

Measurement Data:

Channel No.	Frequency (MHz)	Power Spectral Density (dBm)
4	1921.536	-6.3
0	1928.448	-5.2

Averaged over 100 sweeps.

Requirements, FCC 15.319(d)

The Power Spectral Density shall be less than 3 mW (4.77 dBm) when averaged over 100 sweeps.

Lower Channel:

 Ref Lvl 17 dBm Marker 1 [T1] -6.26 dBm RBW 3 kHz RF Att 20 dB
 140.280561 μ s VBW 10 kHz Unit dBm
 SWT 1 ms

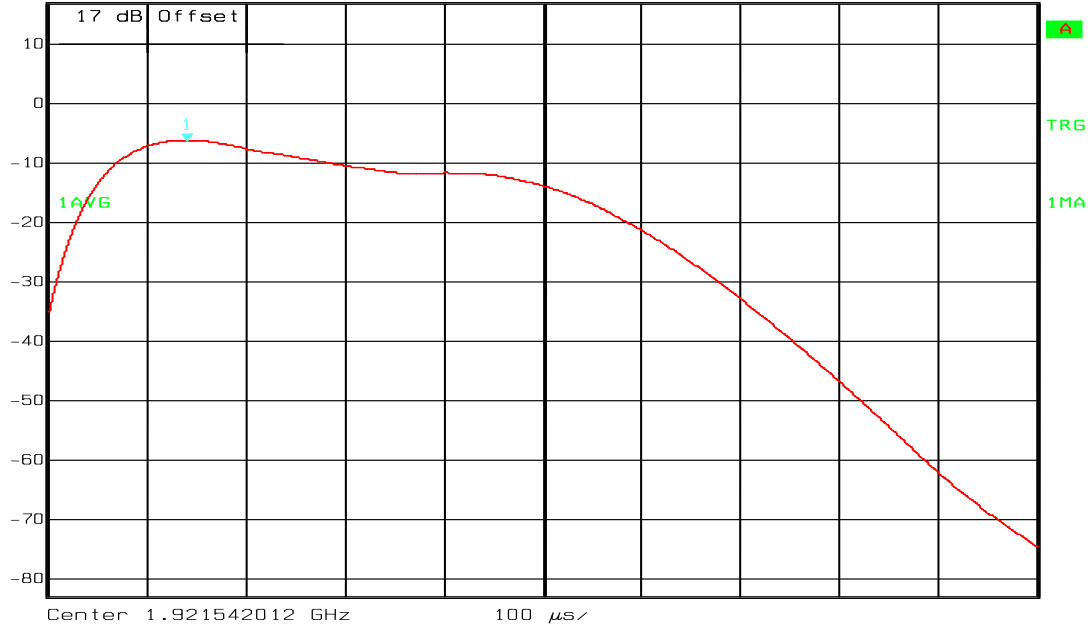

Date: 18.JUL.2006 11:46:20

Power Spectral Density, Averaged, 100 Sweeps

Upper Channel:

 Ref Lvl 9.4 dBm Marker 1 [T1] -5.17 dBm RBW 3 kHz RF Att 20 dB
 360.721443 μ s VBW 10 kHz Unit dBm
 SWT 1 ms

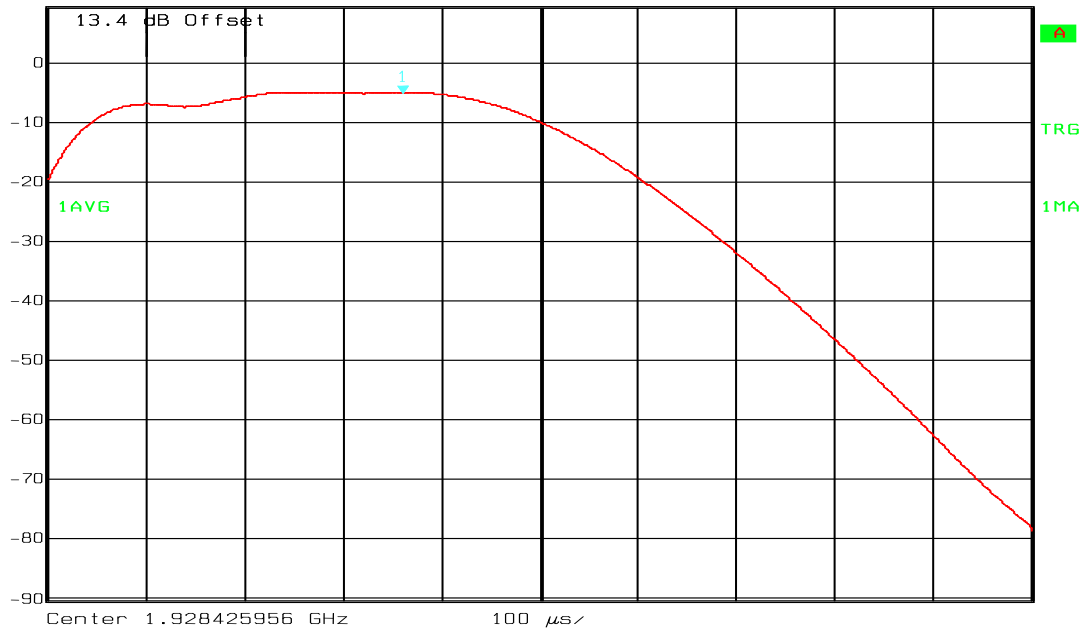

Date: 28.SEP.2006 10:16:22

Power Spectral Density, Averaged, 100 Sweeps

4.11 In-Band Unwanted Emissions, Conducted

Test Method:

ANSI C63.17, clause 6.1.6.1.

Test Results: Complies

Measurement Data:

See plots.

Requirements, FCC 15.323(d):

$B < f \leq 2B$: less than or equal to 30 dB below max. permitted peak power level

$2B < f \leq 3B$: less than or equal to 50 dB below max. permitted peak power level

$3B < f \leq$ UPCS Band Edge : less than or equal to 60 dB below max. permitted peak power level

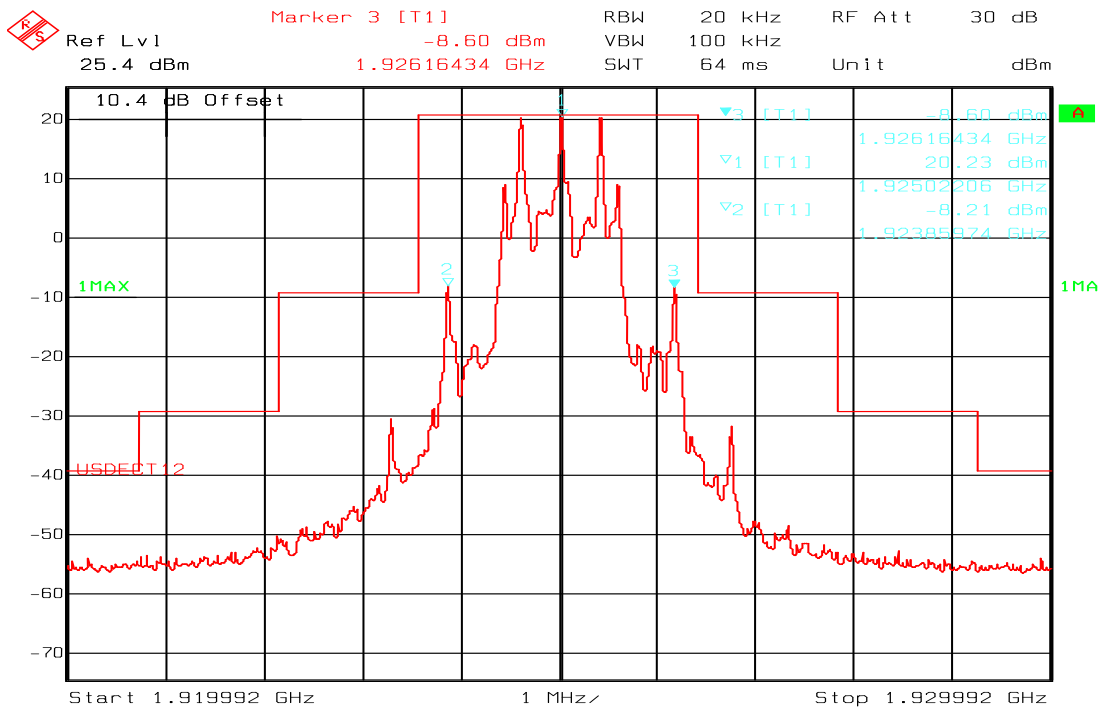

Date: 12.JUL.2006 14:00:26

Middle Channel

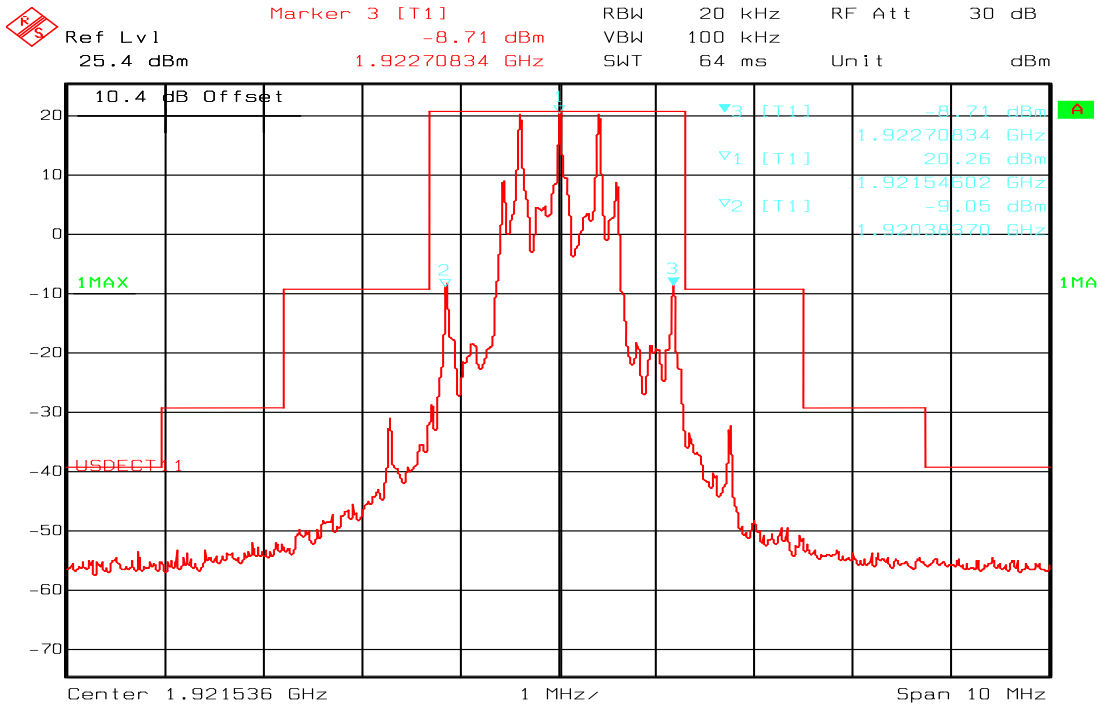

Lower Channel

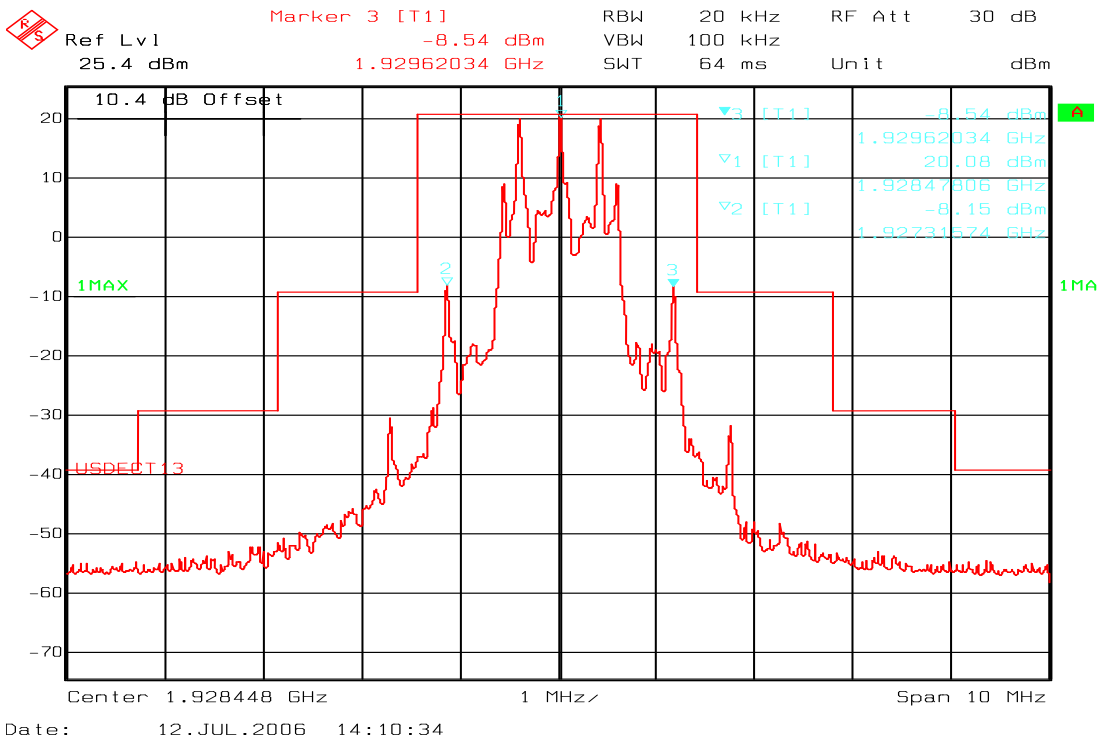

Upper Channel

4.12 Out-of-band Emissions, Conducted

Test Method:

ANSI C63.17, clause 6.1.6.2.

Test Results: Complies

Measurement Data:

See plots.

Requirements, FCC 15.323(d):

$f \leq 1.25\text{MHz}$ outside UPCS band : $\leq -9.5\text{dBm}$
 $1.25\text{MHz} \leq f \leq 2.5\text{MHz}$ outside UPCS band : $\leq -29.5\text{ dBm}$
 $f \geq 2.5\text{MHz}$ outside UPCS band : $\leq -39.5\text{ dBm}$

Upper Channel:

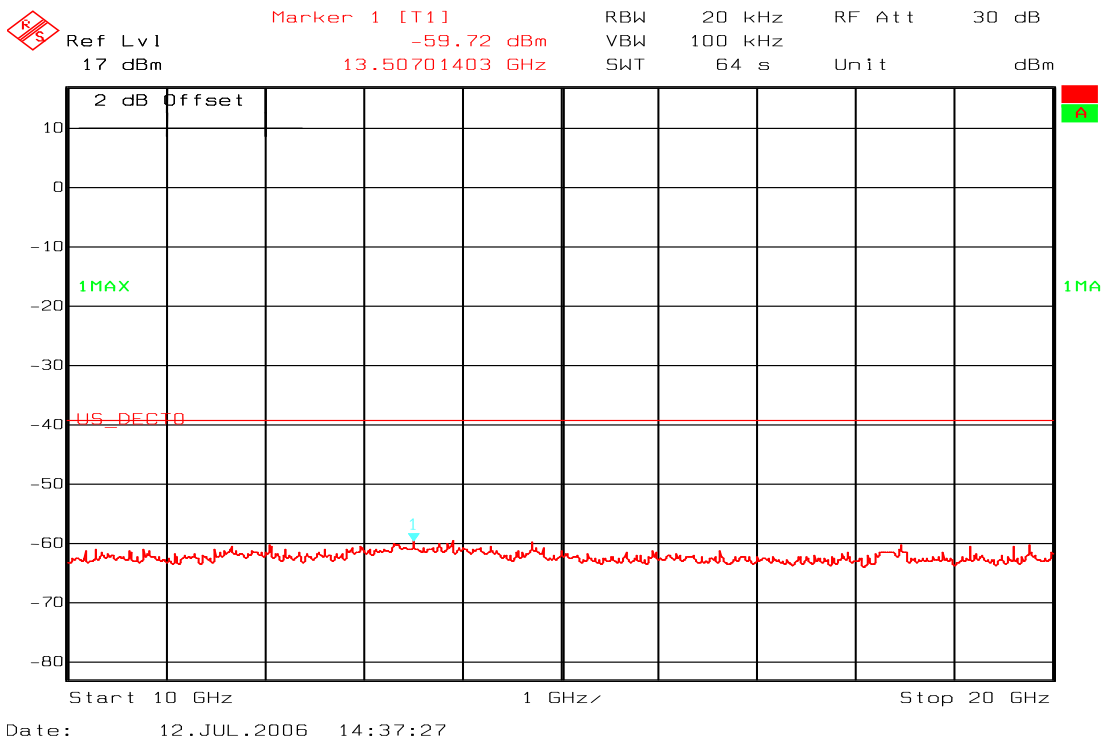

Out-of-Band Emissions, Conducted

Lower Channel:

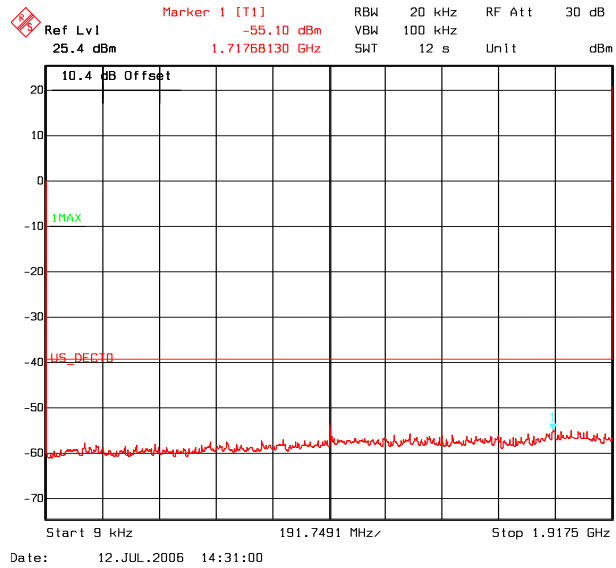
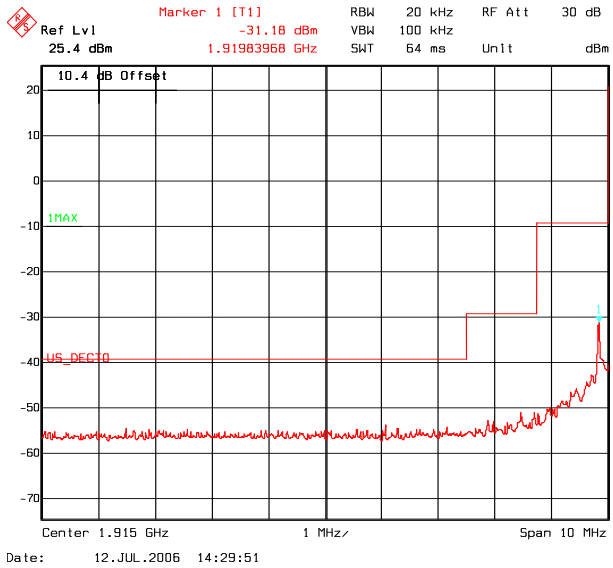

Upper Channel:

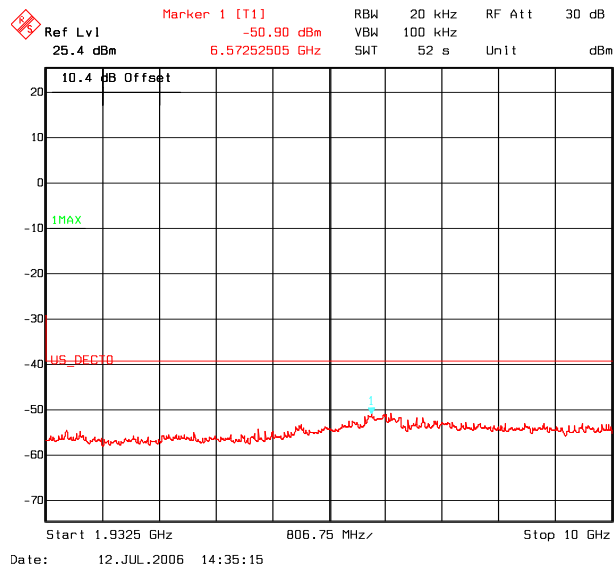
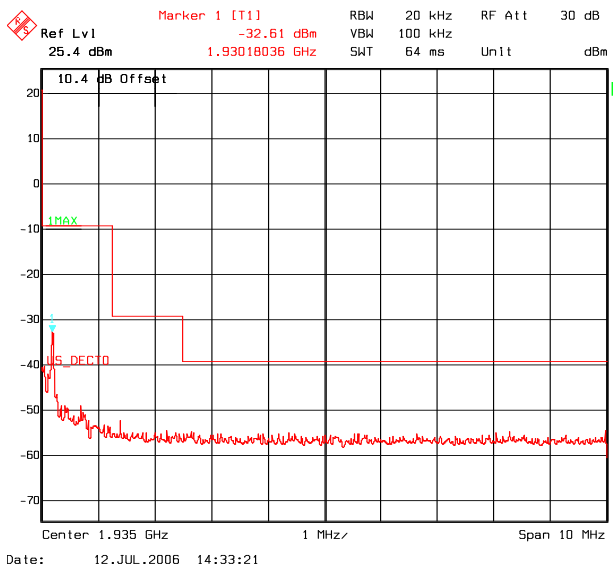

4.13 Carrier Frequency Stability

Test Method:

ANSI C63.17, clause 6.2.1.

Test Results: Complies

Measurement Data:

The Carrier frequency stability is measured directly with a Frequency Domain Analyzer in histogram mode. Frequency Deviation in ppm is calculated.

Frequency Stability over 1 hour of operation at Nominal Temperature

Voltage	Measured Carrier Frequency (MHz)	Pk-Pk Difference (kHz)	Deviation ppm	Limit
V _{nom}	1924.965	27.3	7.1	10 ppm

$$\text{Deviation ppm} = ((\text{Pk-Pk difference} / 2) / \text{Mean}) \times 10^6$$

Frequency Stability over Power Supply Voltage at Nominal Temperature

Voltage	Measured Carrier Frequency (MHz)	Difference (kHz)	Deviation ppm	Limit
V _{nom}	N/A	0	0	10 ppm
85% of V _{nom}	N/A	N/A	N/A	
115% of V _{nom}	N/A	N/A	N/A	

$$\text{Deviation ppm} = ((\text{Mean} - \text{Measured Frequency}) / \text{Mean}) \times 10^6$$

Comment: This test is not required for battery operated equipment.

Frequency Stability over Temperature

Temperature	Measured Carrier Frequency (MHz)	Difference (kHz)	Deviation ppm	Limit
T = +20 °C	1924.965197	0	0	10 ppm
T = -20 °C	1924.952357	-12.8	6.7	
T = +50 °C	1924.958674	-6.5	3.4	

$$\text{Deviation ppm} = ((\text{Mean} - \text{Measured Frequency}) / \text{Mean}) \times 10^6$$

4.14 Frame Repetition Stability

Test Method:

ANSI C63.17, clause 6.2.2.

Test Results: Complies

Measurement Data:

The envelope of the RF signal from the EUT is detected with a Crystal Detector and the mean and standard deviation of the frame repetition frequency is then gated over 100 frames and measured with a frequency domain analyzer. The frame repetition stability is 3 times the standard deviation.

Carrier Frequency (MHz)	Frame Period Mean (Hz)	Frame Period Standard Deviation (Hz)	Frame Repetition Stability (ppm)
1924.992	99,999655	0.00000198	0.059

Limit:

Frame Repetition Stability	10 ppm (TDMA)
-----------------------------------	---------------

Ref. FCC 15.323(e), ANSI C63.17 clause 6.2.2

4.15 Frame Period and Jitter

Test Method:

ANSI C63.17, clause 6.2.3.

Test Results: Complies

Measurement Data:

Carrier Frequency	Frame Period	Max Jitter (µs)	3xStandard Deviation of Jitter (µs)
1924.992	99.999657	0.0112	0.000594

Max Jitter = (1/ (Frame period + Pk-Pk/2)) - (1/Frame Period), when Pk-Pk and Frame Period are in Hz

Limit:

Frame Period	20 or 10/x ms
Max Jitter	25 µs
3 times St.Dev of Jitter	12.5 µs

Ref. FCC 15.323(e), ANSI C63.17 clause 6.2.3

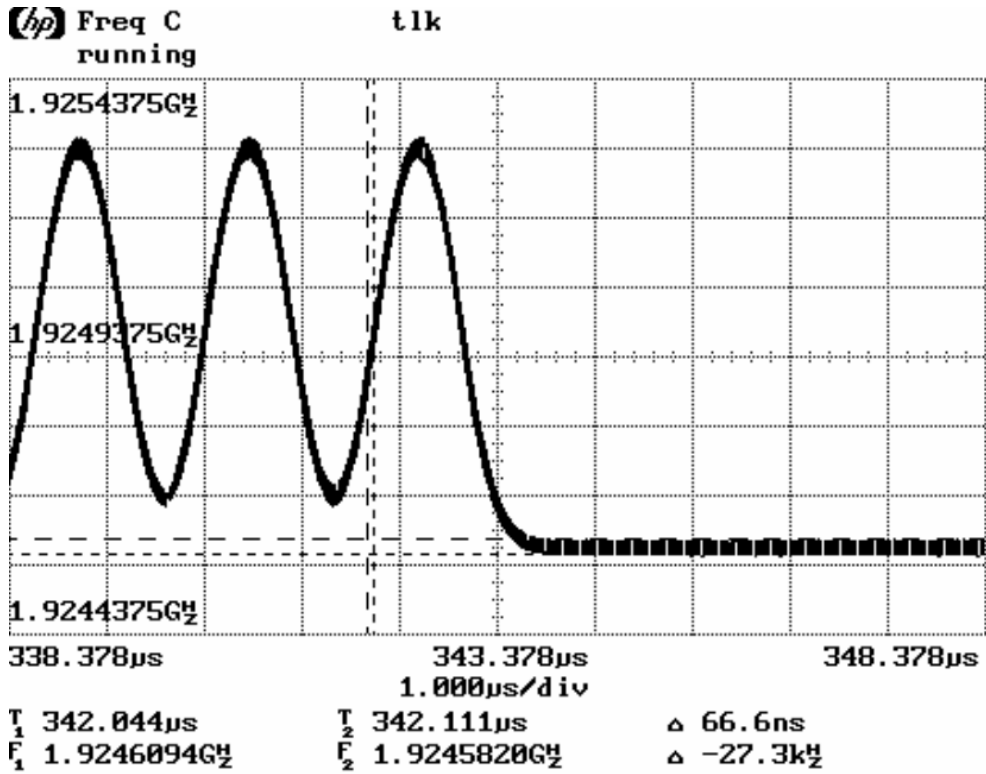

Long Term Carrier Frequency Stability

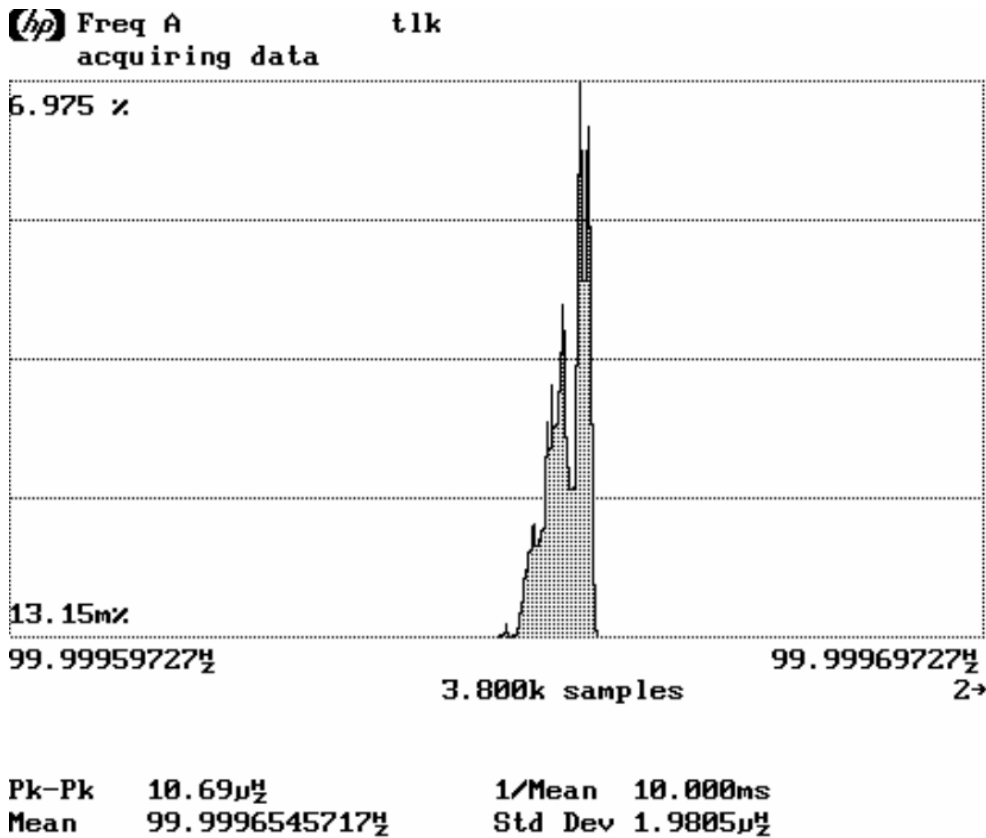

Frame Repetition Stability, Gated over 100 Frames

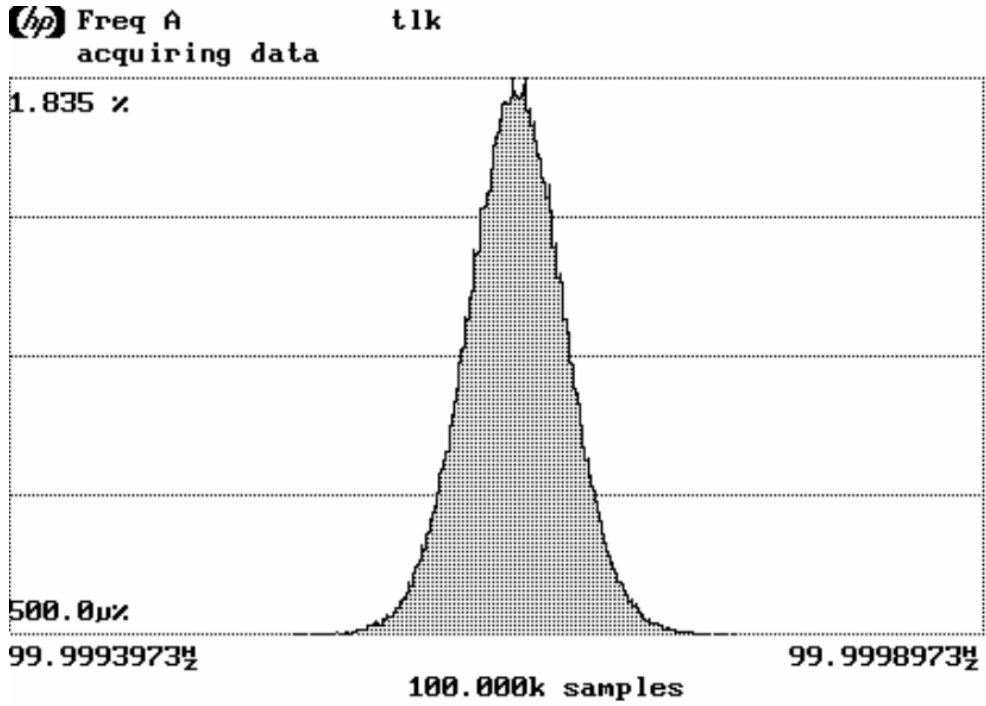

Pk-Pk	224.9µs	1/Mean	10.000ms
Mean	99.9996572810µs	Std Dev	25.1339µs

Frame Period and Jitter

4.16 Monitoring Threshold, Least Interfered Channel

Monitoring Threshold Limits:

Lower Threshold:

$$T_L = 15 \log B - 184 + 30 - P_{EUT} \quad (\text{dBm})$$

Upper Threshold:

$$T_U = 15 \log B - 184 + 50 - P_{EUT} \quad (\text{dBm})$$

B is measured Emission Bandwidth in Hz
 P is measured Transmitter Power in dBm

Calculated values:

Lower Threshold	-82.7 dBm
Upper Threshold	-62.7 dBm

The upper Threshold is applicable for systems which have defined a minimum of 40 duplex system access channels.

Measurement Procedure:

The Upper or Lower Threshold is found by the procedure defined in ANSI C63.17 clause 7.3.1 or 7.3.2.

The value below is found by using the procedure in clause 7.3.2.

Least Interfered Channel	
Lower Threshold	N/A
Upper Threshold	-62.7 dBm

Least Interfered Channel (LIC) Procedure Test, FCC 15.323(b), (c)(2) and (c)(5)

ANSI C63.17 clause 7.3.3 ref.	Observation	Verdict
b) f_1 $T_L + 13$ dB, f_2 at $T_L + 6$ dB	Transmission always on f_2	Pass
c) f_1 $T_L + 6$ dB, f_2 at $T_L + 13$ dB	Transmission always on f_1	Pass
d) f_1 $T_L + 7$ dB, f_2 at T_L	Transmission always on f_2	Pass
e) f_1 T_L , f_2 at $T_L + 7$ dB	Transmission always on f_1	Pass

Selected Channel Confirmation, FCC 15.323(c)(1) and (5)

ANSI C63.17 clause 7.3.4	Observation	Verdict
b) Shall not transmit on f_1	EUT transmits on f_2	Pass
d) Shall not transmit on f_2	EUT transmits on f_1	Pass

Limits:

Lower Threshold + 6 dB margin	-76.7 dBm
Upper Threshold + 6 dB margin	-56.7 dBm

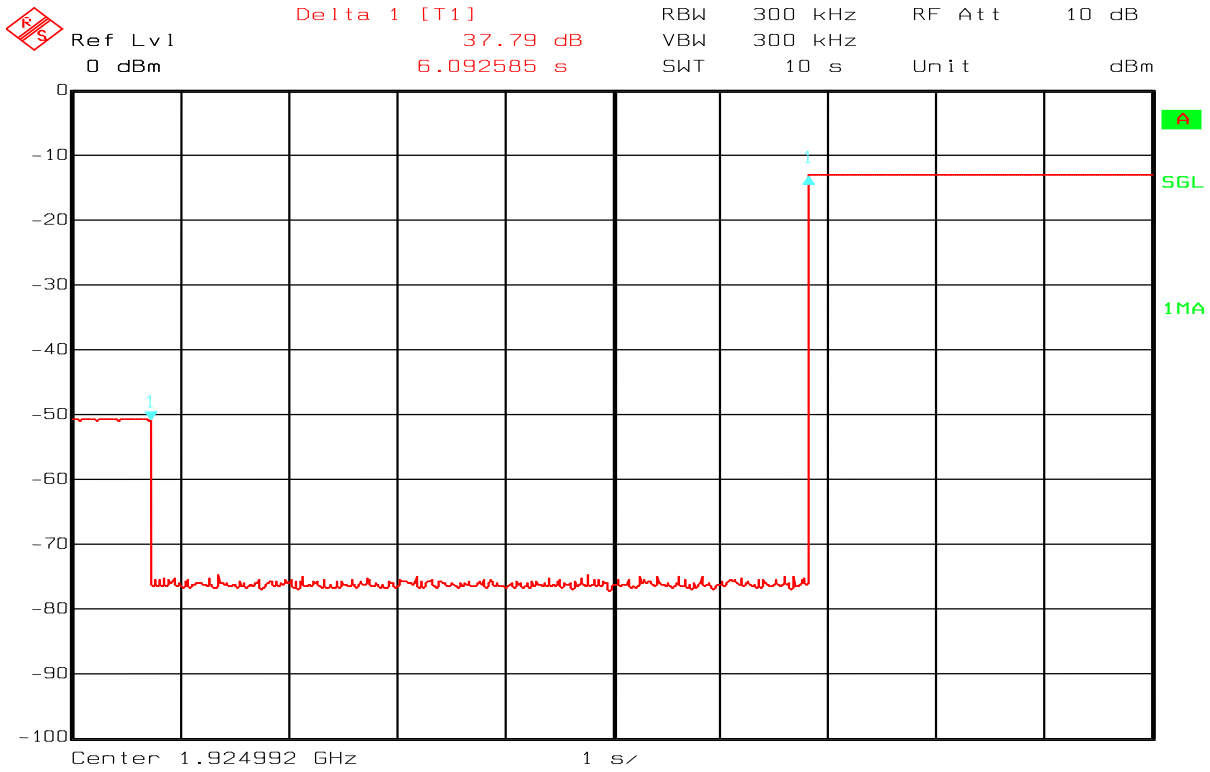

Date: 17.JUL.2006 13:45:46

7.3.4 d) Connection from EUT on f_2 possible 6.1s after interferer is removed

4.17 Threshold Monitoring Bandwidth

This test is only required if a dedicated monitoring receiver is used. However, if the test is not carried out the manufacturer shall declare and provide proper evidence that the monitoring is made through the radio receiver used for communication.

Measurement Procedure:

Simple Compliance Test, ANSI C63.17, clause 7.4.1

More Detailed Test, ANSI C63.17, clause 7.4.2

The test is passed if the Simple Compliance Test is passed or if the More Detailed test is passed.

During this test the spectrum analyzer is observed visually to see if the EUT transmits or not.

Test Results:

Test performed	Observation	Verdict
Simple Compliance test, at $\pm 30\%$ of B	No connection	Pass
More Detailed Test, at -6 dB points	N/A	N/A
More Detailed Test, at -12 dB points	N/A	N/A

The more detailed test must be pass at both the -6 and -12 dB points if the Simple Compliance test fails.

Comment: The tested EUT uses the same receiver for monitoring and communication, this test is therefore not required. However, the test has been performed nonetheless and the test is passed.

Limits, FCC 15.323(c)(7):

The monitoring system bandwidth must be equal to or greater than the emission bandwidth of the intended transmission.

4.18 Reaction Time and Monitoring Interval

Measurement Procedure

ANSI C63.17, clause 7.5

Test results:

By administrative commands and out-of-operating region interference, the EUT is restricted to operate on a single carrier frequency. Time-synchronized pulsed interference is than applied on the carrier at pulsed level $T_U+6\text{dB}$ or $T_L+6\text{dB}$, as appropriate.

The pulses are synchronized with the EUT timeslots and applied centred within all timeslots.

Pulse Width, ref. to ANSI C63.17 clause 7.5	Observation	Verdict
c) $>$ largest of $50\ \mu\text{s}$ and $50*\text{SQRT}(1.25/B)$	No Connection	Pass
d) $>$ largest of $35\ \mu\text{s}$ and $35*\text{SQRT}(1.25/B)$, and with interference level raised 6 dB	No Connection	Pass

Comment: Since B is larger than 1.25 MHz the test was performed with pulse lengths of $50\ \mu\text{s}$ and $35\ \mu\text{s}$.

Limits, FCC 15.323(c)(1), (5) and (7)

The maximum reaction time must be less than $50*\text{SQRT}(1.25/\text{emission bandwidth in MHz})$ microseconds for signals at the applicable threshold level but shall not be required to be less than 50 microseconds.

If a signal is detected that is 6 dB or more above the applicable threshold level, the maximum reaction time shall be $35*\text{SQRT}(1.25/\text{emission bandwidth in MHz})$ microseconds but shall not be required to be less than 35 microseconds.

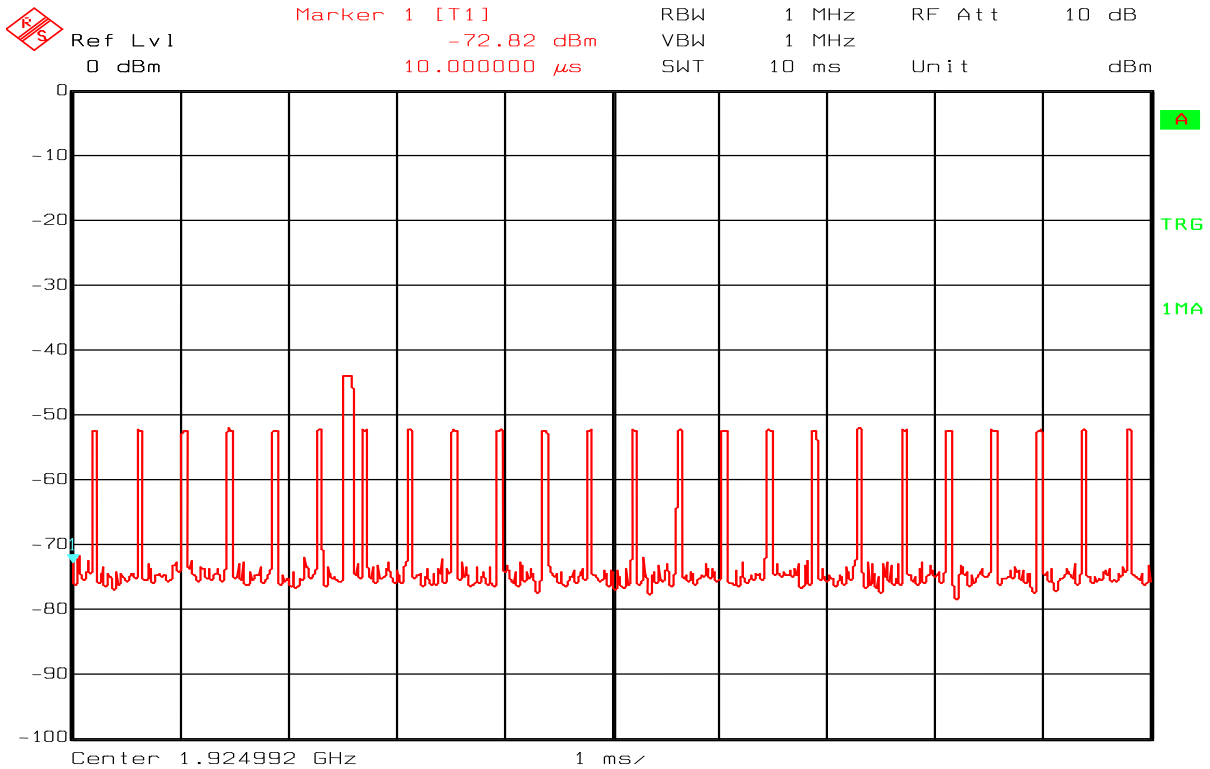

Date: 17.JUL.2006 14:03:56

50 μ s pulses synced to slot

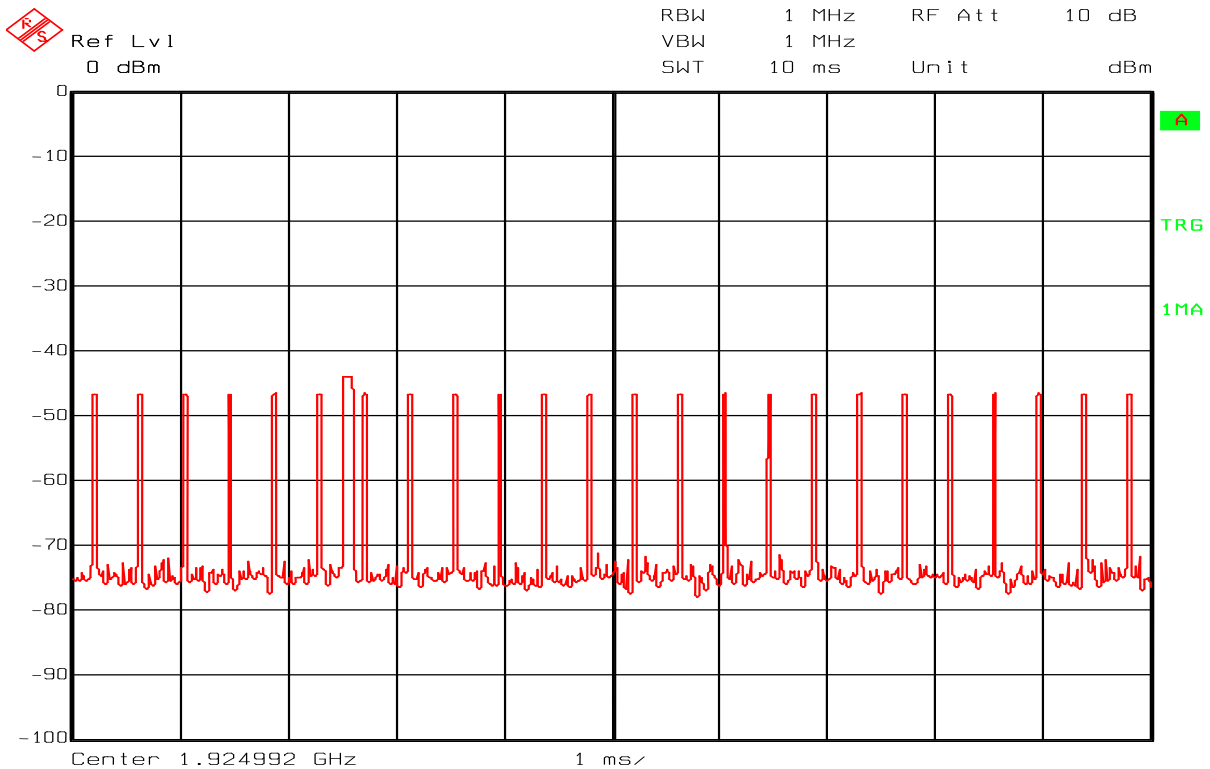

Date: 17.JUL.2006 14:06:00

35 μ s pulses synced to slot

4.19 Time and Spectrum Window Access Procedure

This requirement is only for EUTs which transmit unacknowledged control and signalling information.

Measurement Procedure:

Timing for EUTs using control and signalling channel type transmissions: ANSI C63.17, clause 8.1

Test results:

Access Criteria, ref. to ANSI C63.17 clause 8.1.1	Observation	Verdict
b) Check that the EUT transmits on the interference free time-slot	N/A	N/A

If FCC 15.323(c)(6) option, **If Random Waiting Interval is NOT implemented**

Access Criteria, ref. to ANSI C63.17 clause 8.1.2	Observation	Verdict
b) Check that the EUT changes to an interference-free slot when interference is introduced on the time slot in use	N/A	N/A

If FCC 15.323(c)(6) option, **Only if Random Waiting Interval is implemented**

Access Criteria, ref. to ANSI C63.17 clause 8.1.3	Observation	Verdict
b-d) Check that the EUT uses random waiting interval before continuing transmission on an interfered time slot	N/A	N/A

Comment: This test is not applicable since the tested EUT does not transmit unacknowledged control and signalling information.

Limits:

FCC 15.323(c)(4):

Once access to specific combined time and spectrum windows is obtained an acknowledgement from a system participant must be received by the initiating transmitter within one second or transmission must cease. Periodic acknowledgements must be received at least every 30 seconds or transmission must cease. Channels used exclusively for control and signalling information may transmit continuously for 30 seconds without receiving an acknowledgement, at which time the access criteria must be repeated.

FCC 15.323(c)(6):

If the selected combined time and spectrum windows are unavailable, the device may either monitor and select different windows or seek to use the same windows after waiting an amount of time, randomly chosen from a uniform random distribution between 10 and 150 milliseconds, commencing when the channel becomes available

4.20 Acknowledgements and Transmission Duration

Measurement Procedure:

Acknowledgements: ANSI C63.17, clause 8.2.1

Transmission Duration: ANSI C63.17, clause 8.2.2

Test Results:

Acknowledgements

Test ref. to ANSI C63.17 clause 8.2.1	Observation	Verdict
a) Initial transmission without acknowledgements	No transmissions observed.	Pass
c) transmission time after cease of acknowledgements	5.0 sec	Pass

Transmission Duration

Test ref. to ANSI C63.17 clause 8.2.2	Observation	Verdict
b) Transmission duration on same time and frequency window	8 min	Pass

Comment: Transmission duration was monitored on the spectrum analyzer by a computer.

Limits, FCC 15.323(c)(3) and (4)

Occupation of the same combined time and spectrum windows by a device or group of cooperating devices continuously over a period of time longer than 8 hours is not permitted without repeating the access criteria.

Once access to specific combined time and spectrum windows is obtained an acknowledgement from a system participant must be received by the initiating transmitter within one second or transmission must cease.

Periodic acknowledgements must be received at least every 30 seconds or transmission must cease. Channels used exclusively for control and signalling information may transmit continuously for 30 seconds without receiving an acknowledgement, at which time the access criteria must be repeated.

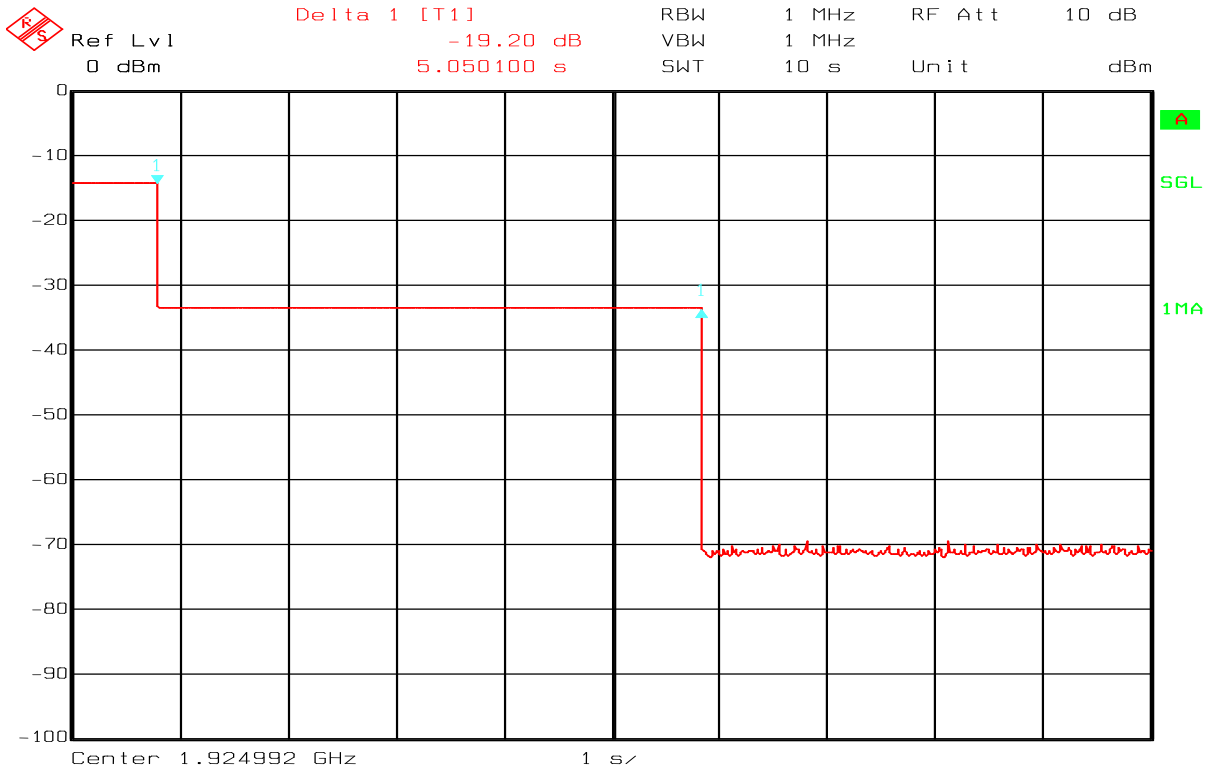

Date: 17.JUL.2006 15:26:33

8.2.1.c) Transmission time after cease of acknowledgements

4.21 Dual Access Criteria Check

Measurement Procedure:

EUTs that does not implement the Upper Threshold: ANSI C63.17, clause 8.3.1

EUTs that implement the Upper Threshold: ANSI C63.17, clause 8.3.2

This test is required for equipment that uses the access criteria in FCC 15.323(c)(10).

Test Results:

EUTs that Implements the Upper Threshold:

Test ref. to ANSI C63.17 clause 8.3.2	Observation	Verdict
b) EUT is restricted to a single carrier f_c for TDMA systems. The Test is Pass if EUT can transmit	EUT can transmit	Pass
c) d) Transmission on interference-free receive time/spectrum window	EUT transmits on interference free receive slot.	Pass
e) f) Transmission on interference-free transmit time/spectrum window	EUT transmits on interference free transmit slot.	Pass
g) Transmission not possible on any time/spectrum window	No connection possible	Pass

Comment: See plots.

Limits, FCC 15.323(c)(10)

An initiating device may attempt to establish a duplex connection by monitoring both its intended transmit and receive time and spectrum windows. If both the intended transmit and receive time and spectrum windows meet the access criteria, then the initiating device can initiate a transmission in the intended transmit time and spectrum window. If the power detected by the responding device can be decoded as a duplex connection signal from the initiating device, then the responding device may immediately begin transmitting on the receive time and spectrum window monitored by the initiating device.

4.22 Alternative Monitoring Interval

Test procedure described in ANSI C63.17 clause 8.4.

This test is required if the EUT implements the provisions of FCC 15.323(c)(11).

Test result:

Not Tested. The tested EUT does not implement this provision. See manufacturers' declaration.

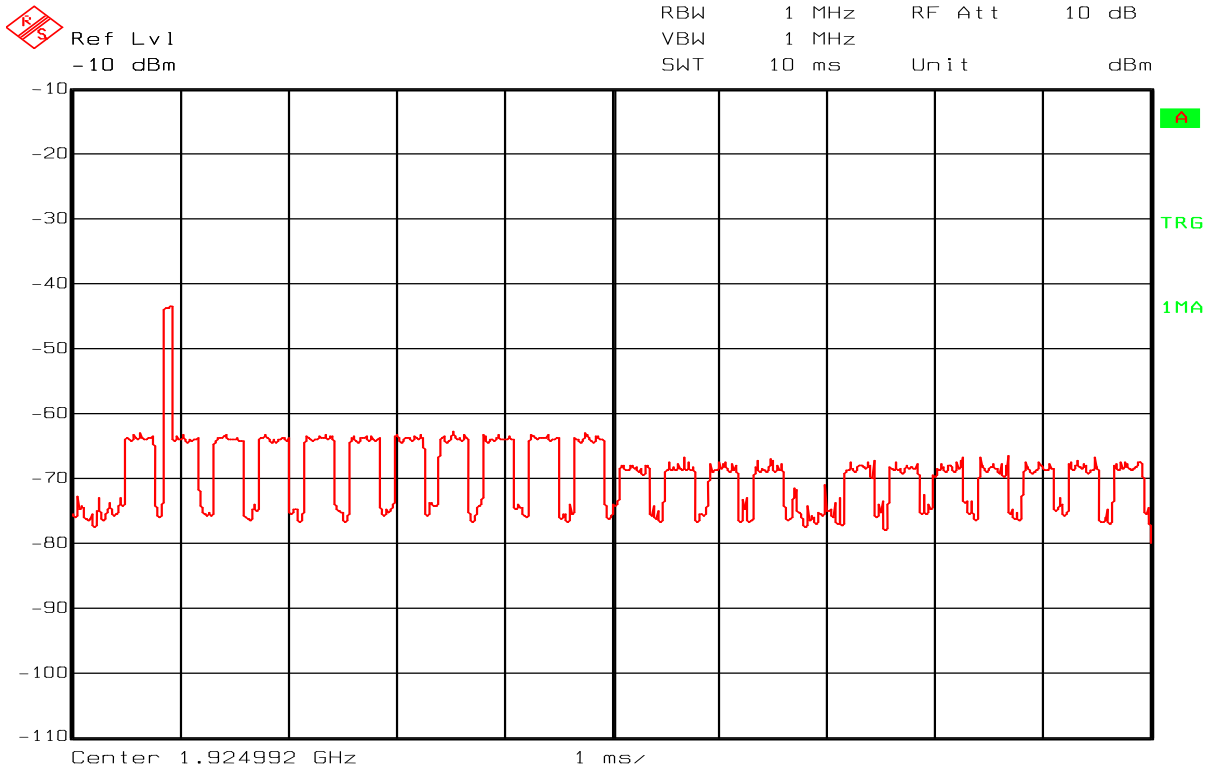

Date: 17.JUL.2006 14:35:56

8.3.2 c) Status before call set-up

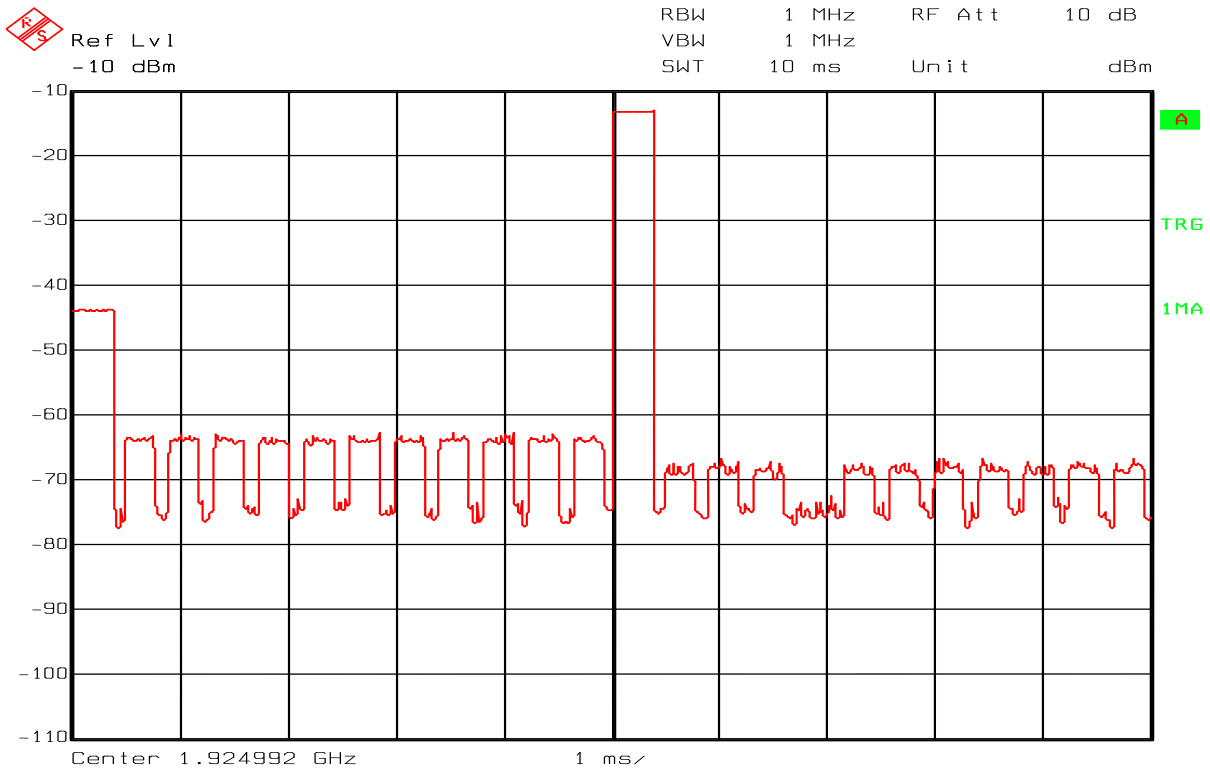

Date: 17.JUL.2006 14:36:40

8.3.2 d) Transmits on interference free RECEIVE slot

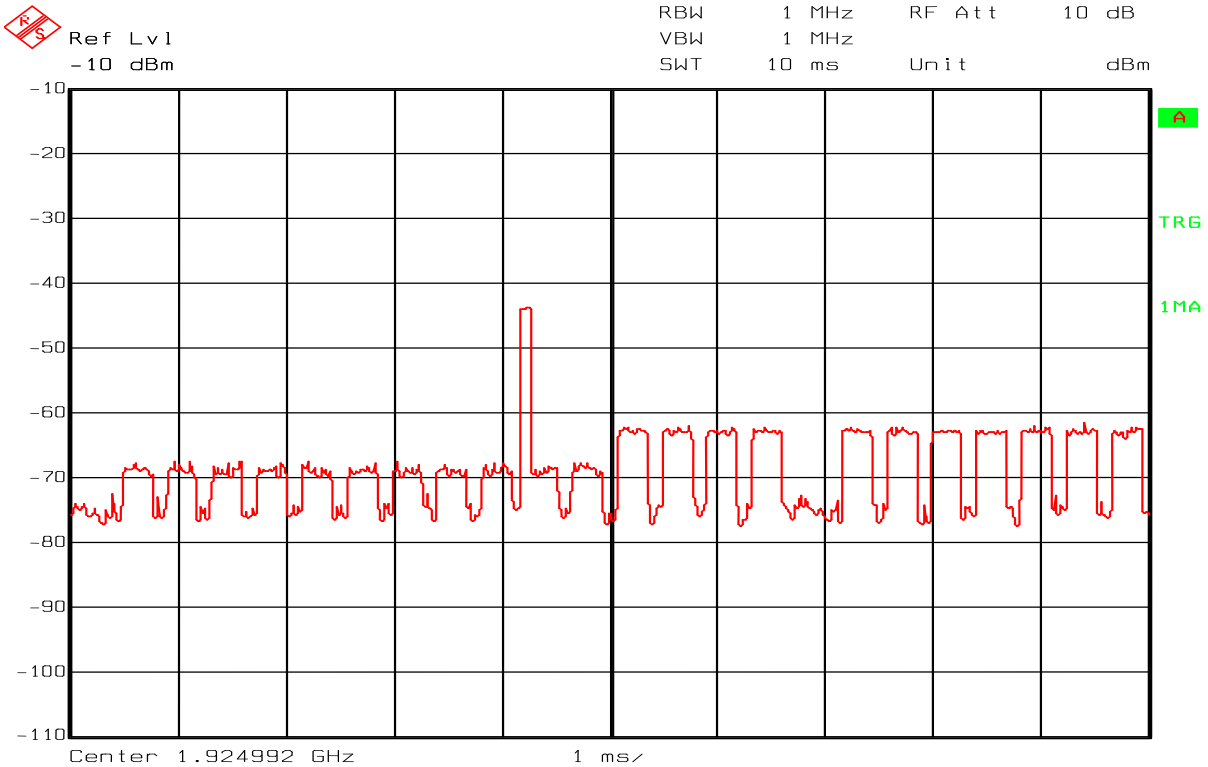

Date: 17.JUL.2006 14:37:48

8.3.2 e) Status before call set-up

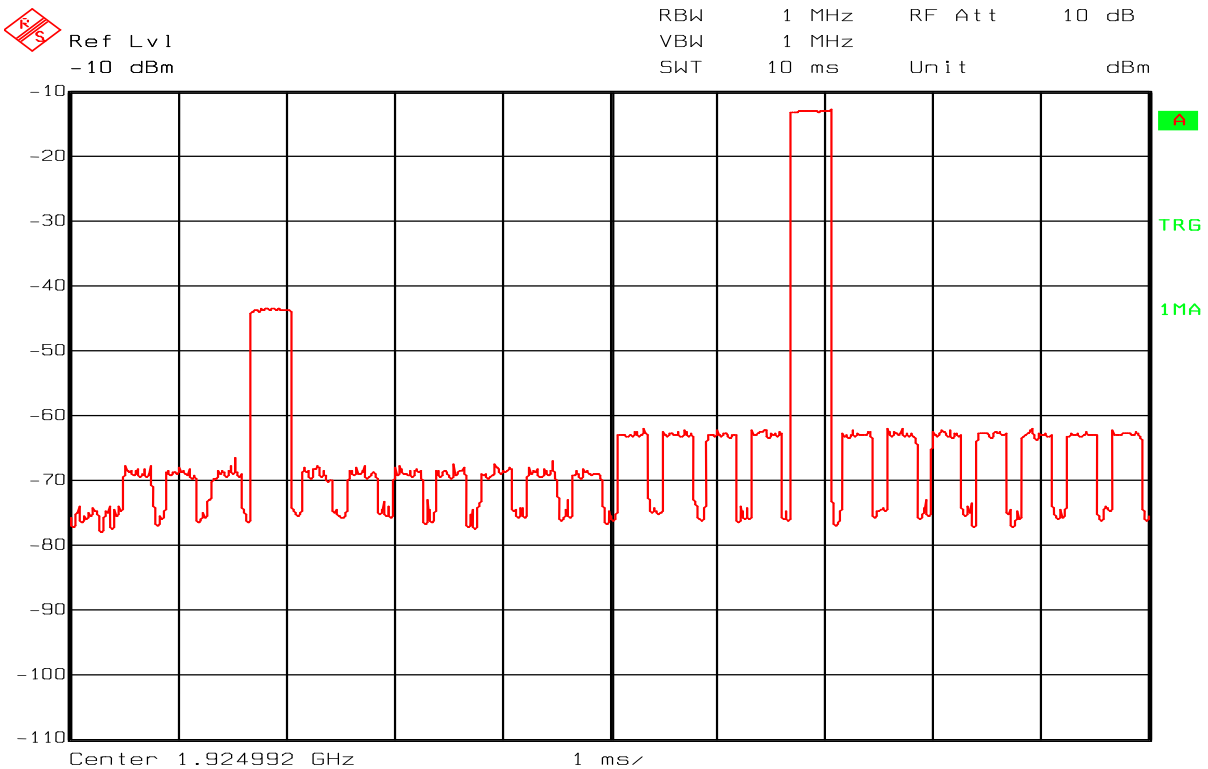

Date: 17.JUL.2006 14:38:15

8.3.2 f) Transmits on interference free TRANSMIT slot

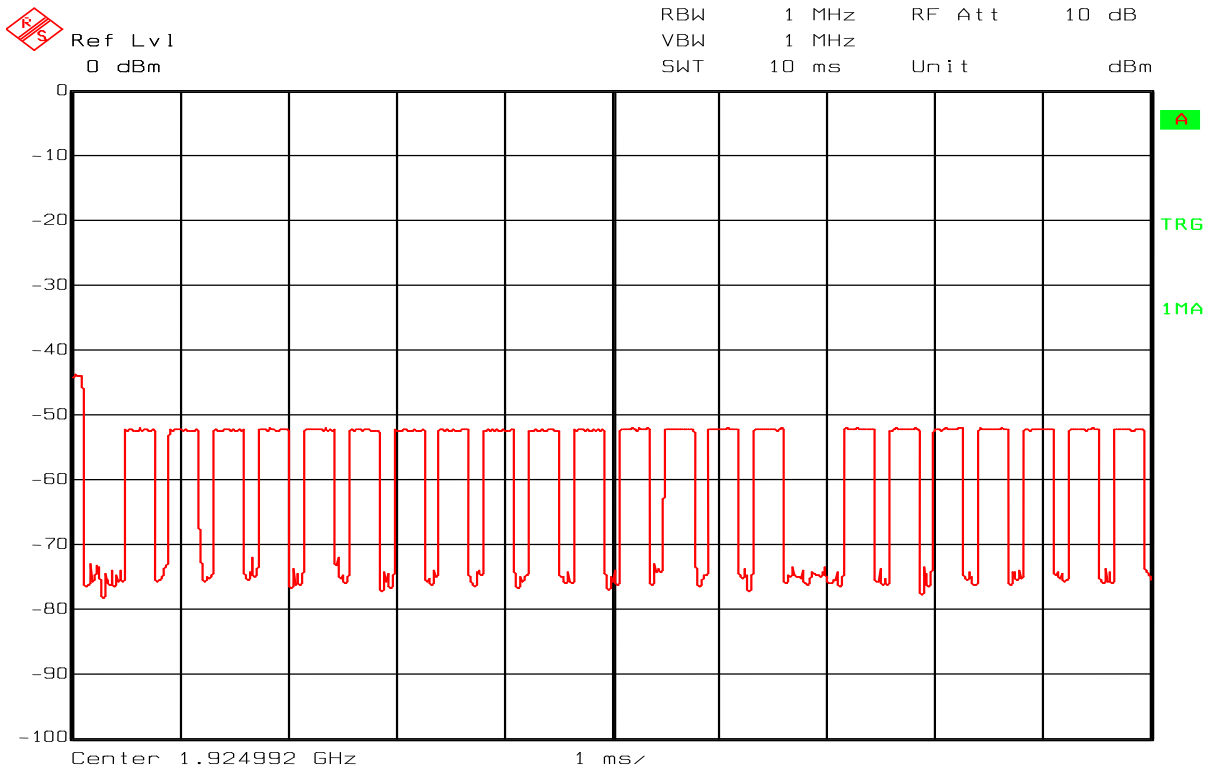

Date: 17.JUL.2006 14:33:45

8.3.2 g) No connection possible

4.23 Duty Cycle Correction Factor Calculation

The tested EUT is a DECT handset that transmits one single timeslot per 10ms DECT system frame.

Frame length: 10ms
 Slot length: 0.525ms

Calculation of DC Correction Factor:

$$-20 \log(\text{slot length} / \text{Frame length}) = -20 \log(0.525/10) = 25.6 \text{ dB}$$

Duty Cycle Correction Factor : 20.0 dB

Max allowed Duty Cycle Correction Factor is 20 dB

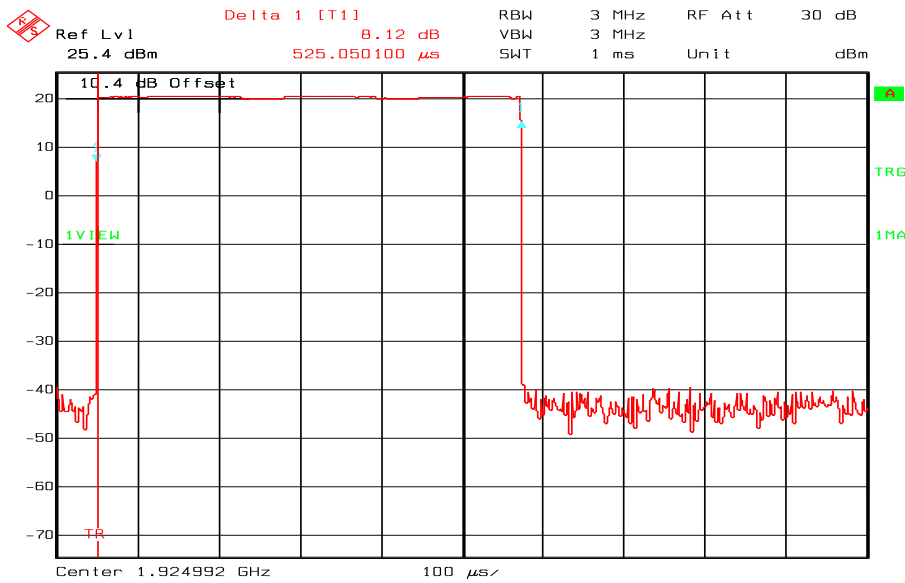

Burst length (TX Burst Mode)

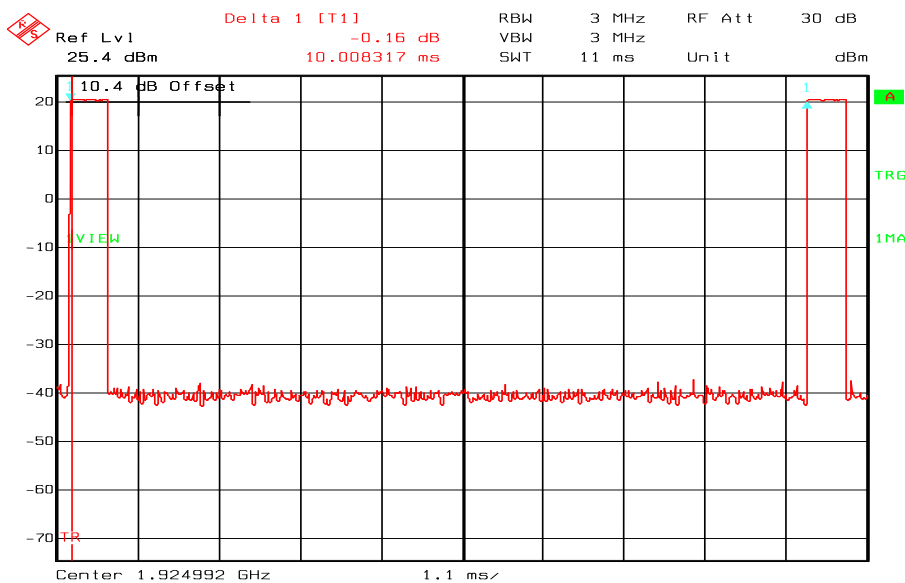

Frame length (TX Burst Mode)

4.24 Spurious Emissions (Radiated)

Measurement Procedure:

FCC 15.209

Test Results:

Radiated emission 10 kHz-30 MHz.

Measuring distance 10 m, measured with Peak detector.

No component detected, see attached graph.

Limit is converted to 10 m using 40 dB/decade according to 15.31 (f) (2).

Transmitter Active, Speech Mode, Handset and Base together

Radiated Emissions 30 - 1000 MHz.

Detector: Quasi-Peak

Measuring distance 3 m.

The EUT were rotated 360 degrees and the antenna height varied between 1 and 4 m on all found frequencies.

Transmitter Active, Speech Mode, Handset and Base together

Frequency MHz	RF channel /	Distance correction factor dB	Field strength, 3 m dB μ V/m	Limit dB μ V/m	Margin dB
124.4	/	0	33.4	43.5	10.1
960.75	/	0	40.7	54.0	13.3

Radiated Emissions 1 - 20 GHz

Detector: Peak

Measuring distance: 1.0 – 8.5 GHz: 3 m
 8.5 – 20.0 GHz: 1 m

The EUT was rotated in 3 planes and emissions were checked on highest and lowest channel.

Transmitter active

Frequenc y GHz	RF channel 00 / 04	Distance correction factor dB	Field strength, 3 m dB μ V/m	Duty cycle correction factor dB	Limit dB μ V/m	Margi n dB
3.84	04	0	53.1	20	54	20.9
5.76	04	0	53.3	20	54	20.7
9.61	04	9.5	47.6	20	54	26.4
11.53	04	9.5	58.5	20	54	25.0
All others	00 / 04	0 or 9.5	< -54	20	54	>20

Important: For the measurements performed at 1 m (8.5 – 20 GHz) the distance correction factor is not included on the plot. This means that the readings on these plots are 9.5 dB higher than the actual value.

Nemko Comlab
Peak

13. Jul 06 10:24

EUT: BeoCom4 UPCS
 Manuf: Bang & Olufsen
 Op Cond: 1m VP
 Operator: FS
 Test Spec: FCC 15.209, 3m
 Comment: Handset and Base
 Speech Mode

Scan Settings (1 Range)

Frequencies			Receiver Settings					
Start	Stop	Step	IF BW	Detector	M-Time	Atten	Preamp	OpRge
30M	200M	50k	120k	PK	50ms	AUTO	LN ON	60dB

Transducer No.	Start	Stop	Name
20	30M	200M	HK116

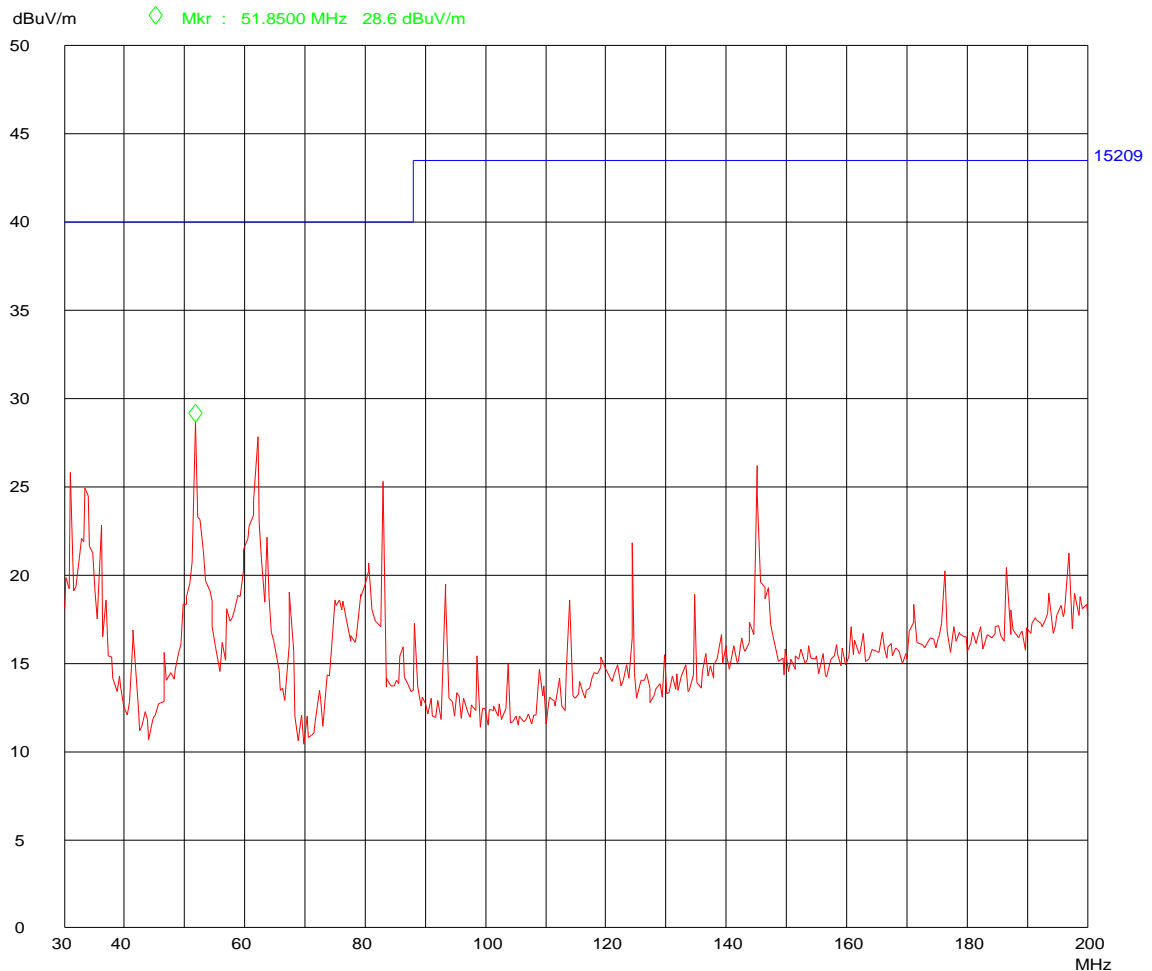

Spurious Emissions 30 – 200 MHz, Peak Detector, Vertical Polarization

Nemko Comlab
 Peak

13. Jul 06 10:36

EUT: BeoCom4 UPCS
 Manuf: Bang & Olufsen
 Op Cond: 2m HP
 Operator: FS
 Test Spec: FCC 15.209, 3m
 Comment: Handset and Base
 Speech Mode

Scan Settings (1 Range)

Frequencies			Receiver Settings					
Start	Stop	Step	IF BW	Detector	M-Time	Atten	Preamp	OpRge
30M	200M	50k	120k	PK	50ms	AUTO	LN ON	60dB

Transducer No.	Start	Stop	Name
20	30M	200M	HK116

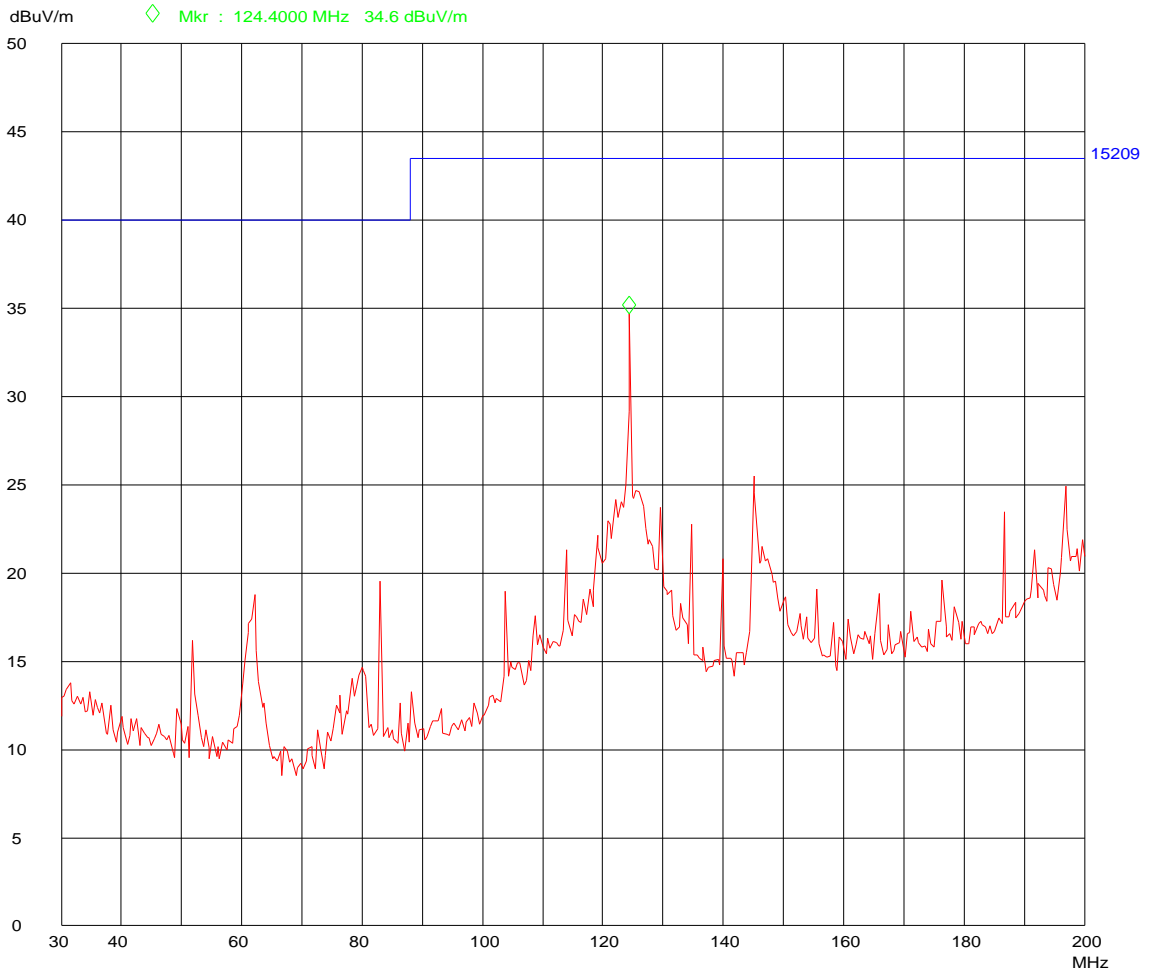

Spurious Emissions 30 – 200 MHz, Peak Detector, Horizontal Polarization

Nemko Comlab
 Peak

13. Jul 06 09:24

EUT: BeoCom4 UPCS
 Manuf: Bang & Olufsen
 Op Cond: 1m VP
 Operator: FS
 Test Spec: FCC 15.209, 3m
 Comment: Handset and Base
 Speech Mode

Scan Settings (1 Range)

Frequencies			Receiver Settings					
Start	Stop	Step	IF BW	Detector	M-Time	Atten	Preamp	OpRge
200M	1000M	50k	120k	PK	50ms	AUTO	LN ON	60dB

Transducer No.	Start	Stop	Name
21	200M	1000M	HL223

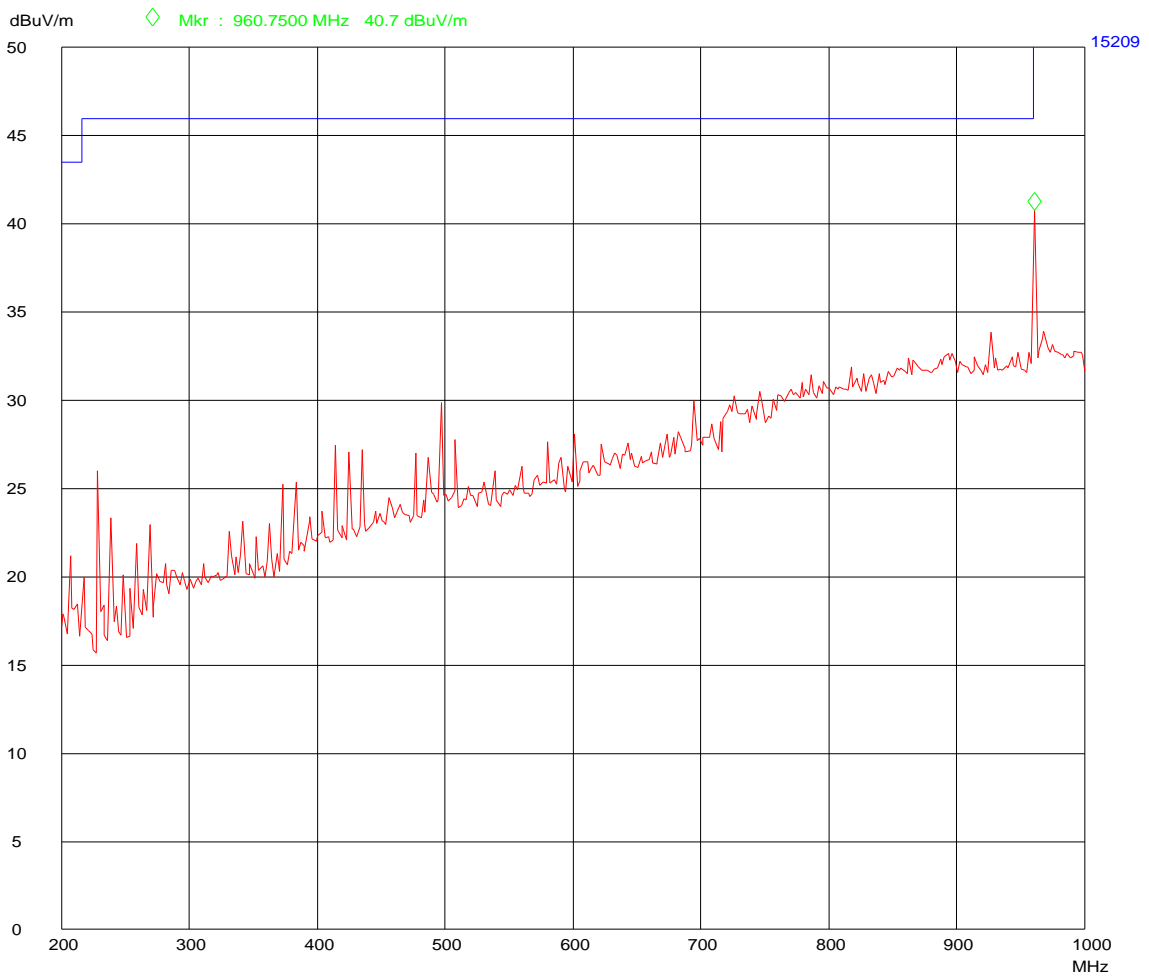

Spurious Emissions 200 - 1000 MHz, Peak Detector, Vertical Polarization

Nemko Comlab
 Peak

13. Jul 06 09:49

EUT: BeoCom4 UPCS
 Manuf: Bang & Olufsen
 Op Cond: 2m HP
 Operator: FS
 Test Spec: FCC 15.209, 3m
 Comment: Handset and Base
 Speech Mode

Scan Settings (1 Range)

Frequencies			Receiver Settings					
Start	Stop	Step	IF BW	Detector	M-Time	Atten	Preamp	OpRge
200M	1000M	50k	120k	PK	50ms	AUTO	LN ON	60dB

Transducer No.	Start	Stop	Name
21	200M	1000M	HL223

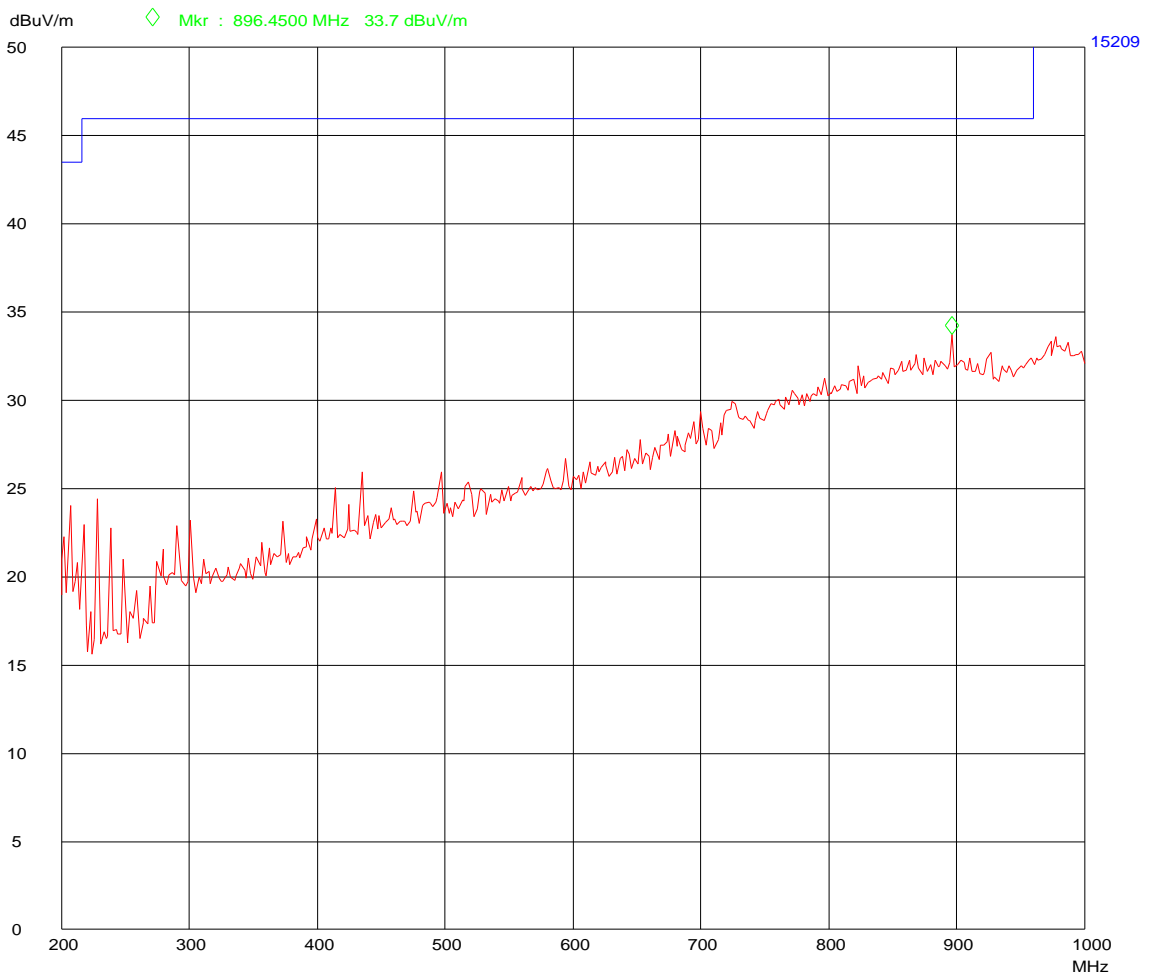

Spurious Emissions 200 - 1000 MHz, Peak Detector, Horizontal Polarization

NEMKO COMLAB

14. Jul 06 11:52

Peak

Operator: FS
 Comment: Bang % Olufsen
 BeoCom4, Base and Handset
 FCC 15.209, 10m
 Speech Mode

Scan Settings (4 Ranges)

Frequencies			Receiver Settings					
Start	Stop	Step	IF BW	Detector	M-Time	Atten	Preamp	OpRge
10k	100k	1k	1k	PK	20ms	0dB	LN OFF	60dB
20k	20k	5k	9k	PK	20ms	AUTO	LN ON	60dB
20k	10M	5k	9k	PK	20ms	AUTO	LN OFF	60dB
10M	30M	5k	9k	PK	20ms	AUTO	LN OFF	60dB

Transducer No. Start Stop Name
 13 10k 30M HFH2Z2

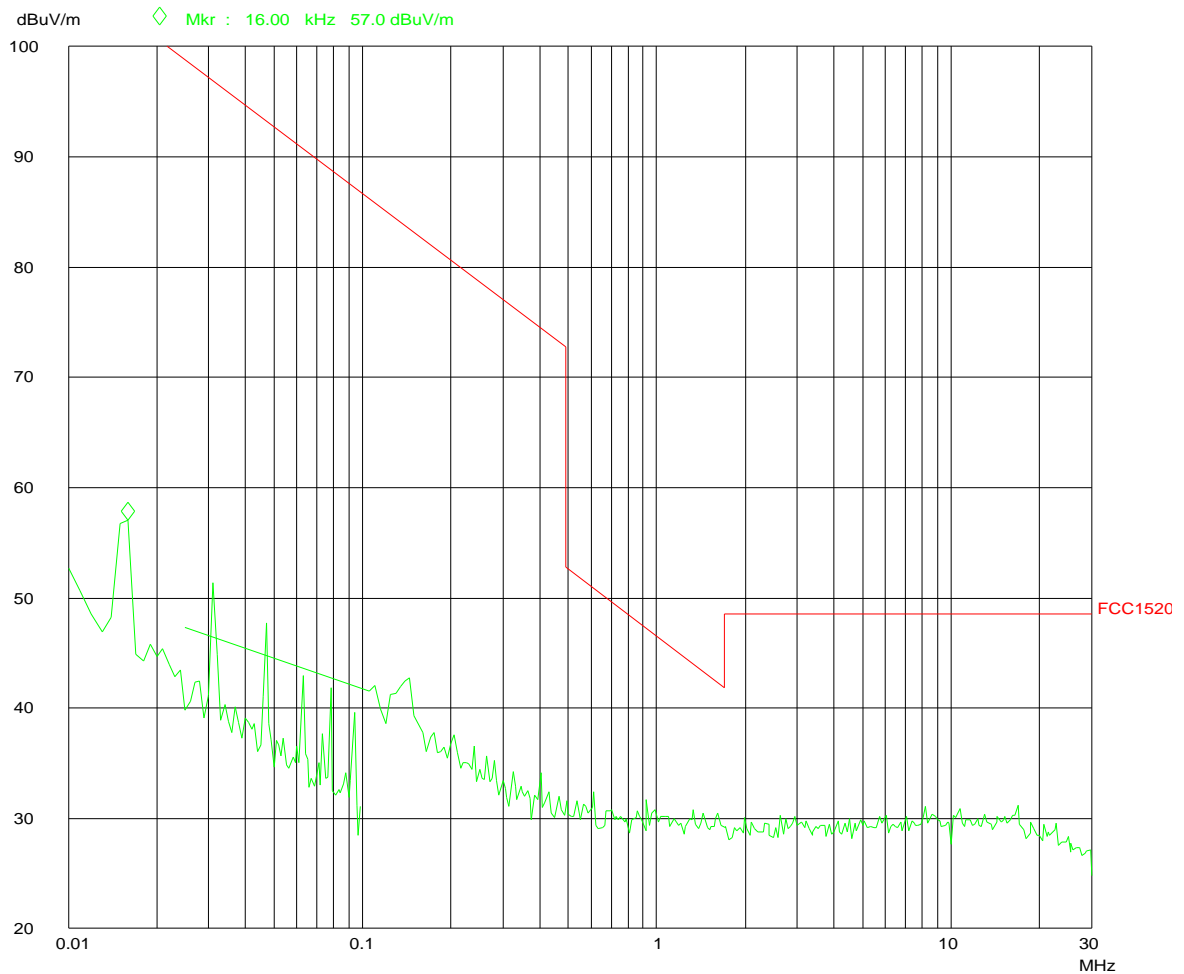

Spurious Emissions 0.010 - 30 MHz, Peak Detector

Marker 1 [T1]
 Ref Lvl 97 dB* 49.62 dB μ V/m RBW 1 MHz RF Att 20 dB
 1.74282565 GHz VBW 1 MHz
 Unit dB μ V/m SWT 5 ms

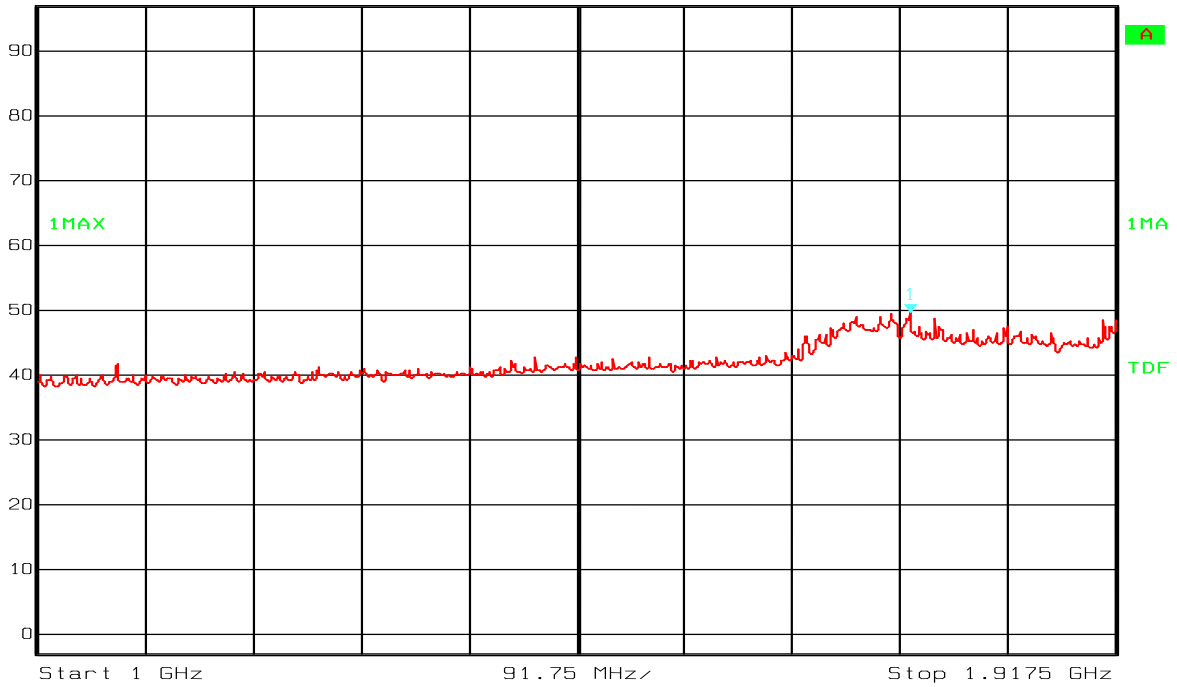

Date: 17.JUL.2006 8:45:02

Spurious Emissions 1 – 1.9175 GHz

Marker 3 [T1]
 Ref Lvl 97 dB* 55.08 dB μ V/m RBW 1 MHz RF Att 0 dB
 7.68436874 GHz VBW 1 MHz
 Unit dB μ V/m SWT 32 ms

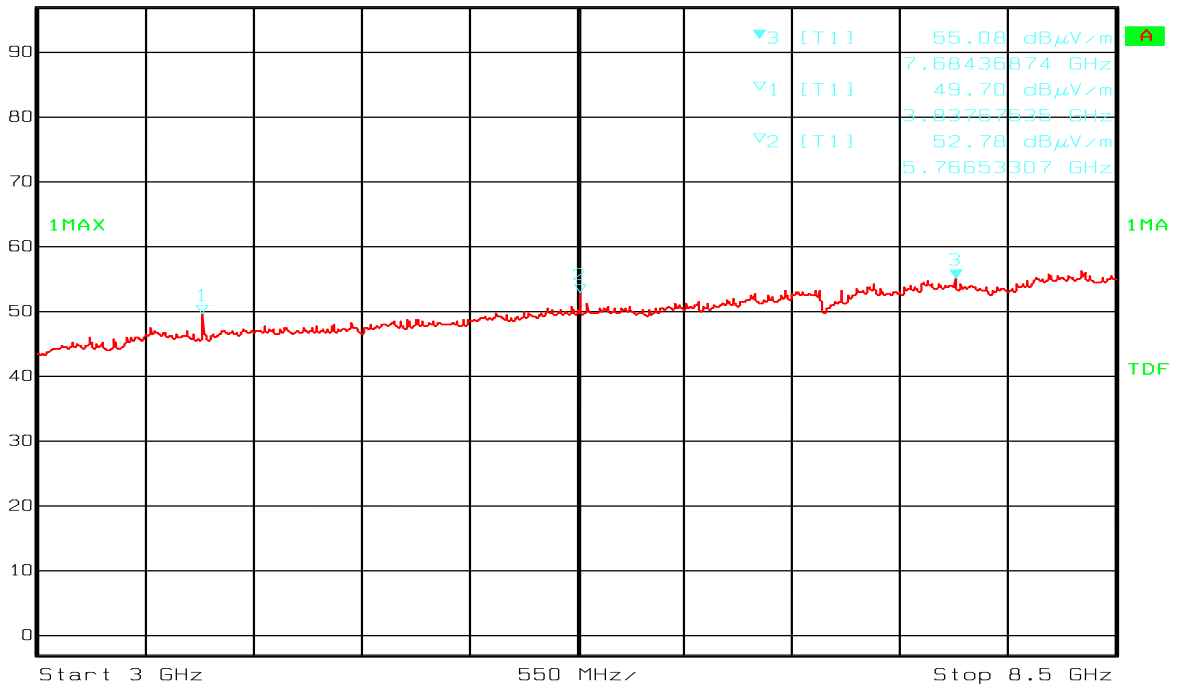

Date: 17.JUL.2006 8:33:09

Spurious Emissions 3 – 8.5 GHz

◆ Ref Lvl 97 dB*
 Marker 2 [T1] 57.53 dB μ V/m
 RBW 1 MHz RF Att 0 dB
 11.53006012 GHz
 VBW 1 MHz
 Unit dB μ V/m
 SWT 20 ms

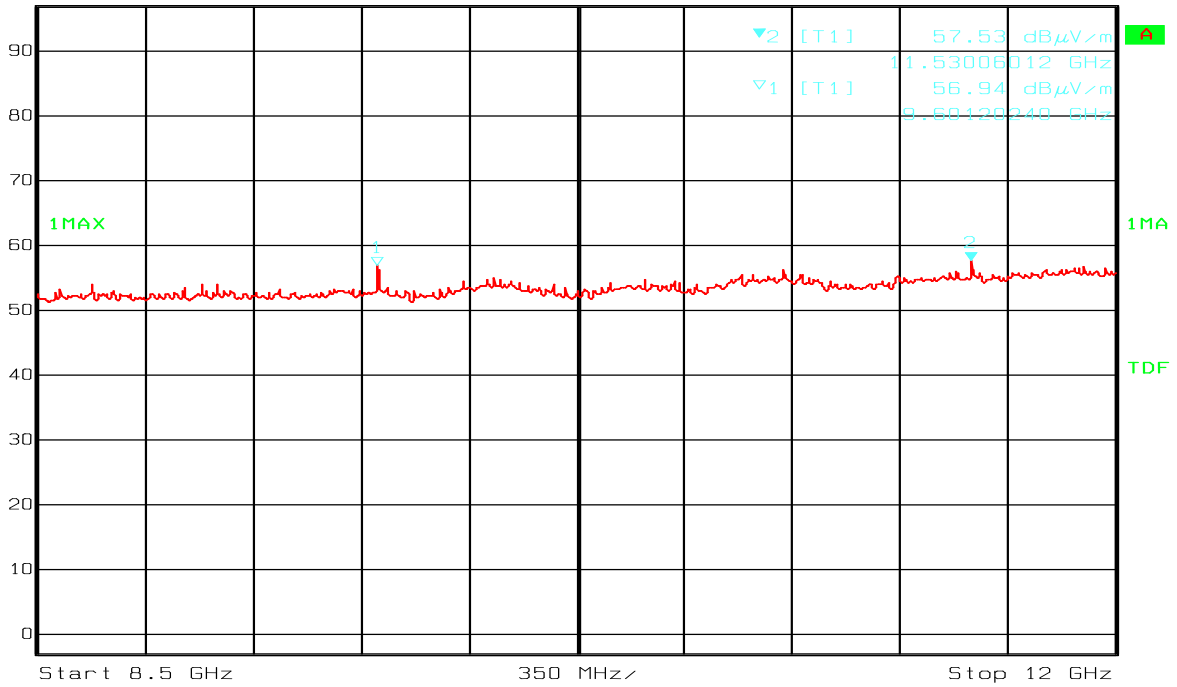

Date: 17.JUL.2006 8:03:57

Spurious Emissions 8.5 – 12 GHz

◆ Ref Lvl 97 dB*
 Marker 1 [T1] 60.89 dB μ V/m
 RBW 1 MHz RF Att 0 dB
 17.83166333 GHz
 VBW 1 MHz
 Unit dB μ V/m
 SWT 34 ms

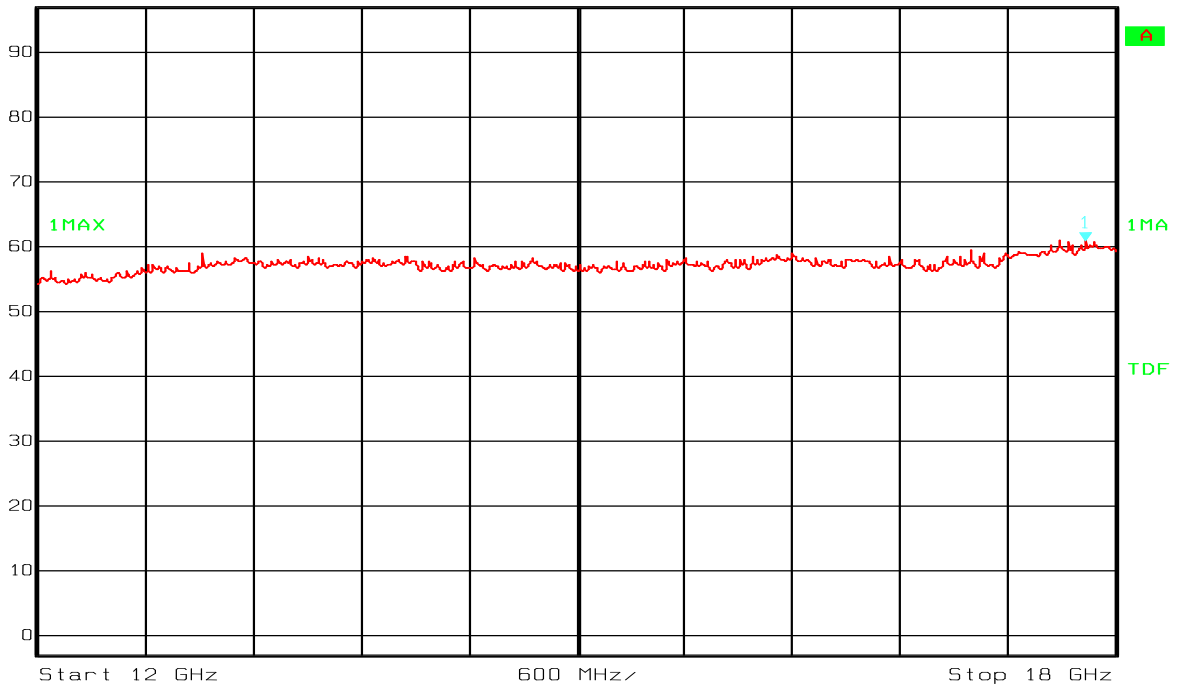

Date: 17.JUL.2006 7:58:43

Spurious Emissions 12 – 18 GHz

	Ref Lvl	Marker 1 [T1]	RBW	1 MHz	RF Att	0 dB
	97 dB*	53.10 dB μ V/m	VBW	1 MHz		
		3.84311222 GHz	SWT	5 ms	Unit	dB μ V/m

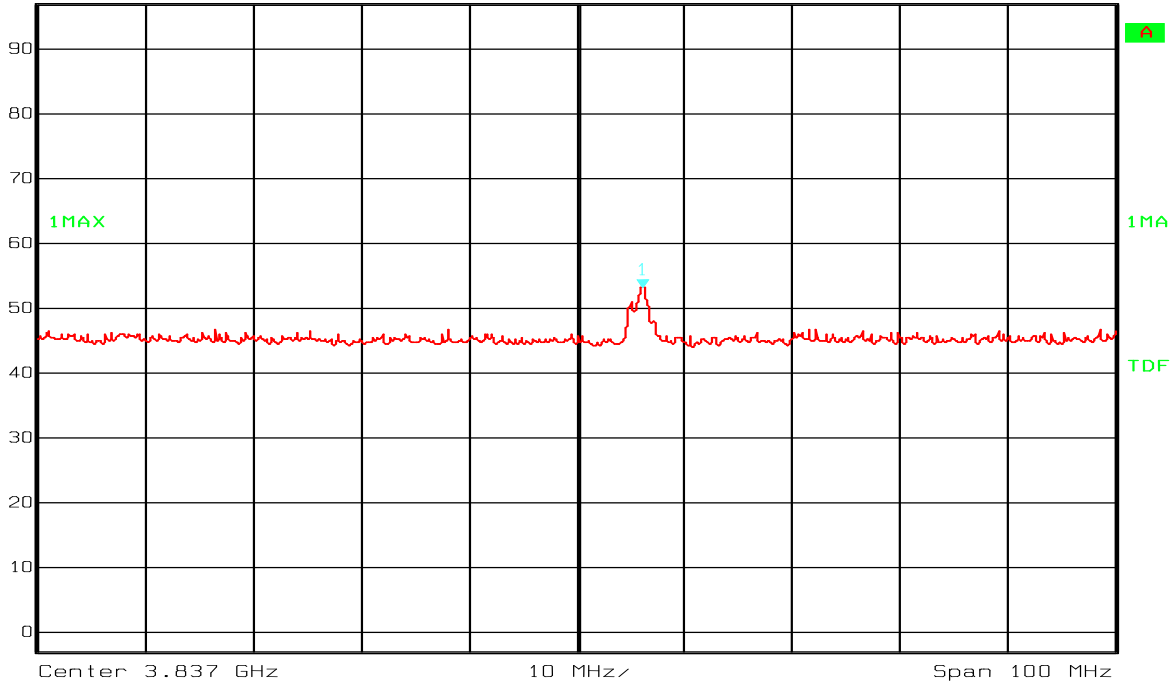

Date: 17.JUL.2006 8:36:20

Spurious Emissions 3.84 GHz (Second Harmonic)

	Ref Lvl	Marker 1 [T1]	RBW	1 MHz	RF Att	0 dB
	97 dB*	53.31 dB μ V/m	VBW	1 MHz		
		5.76589980 GHz	SWT	5 ms	Unit	dB μ V/m

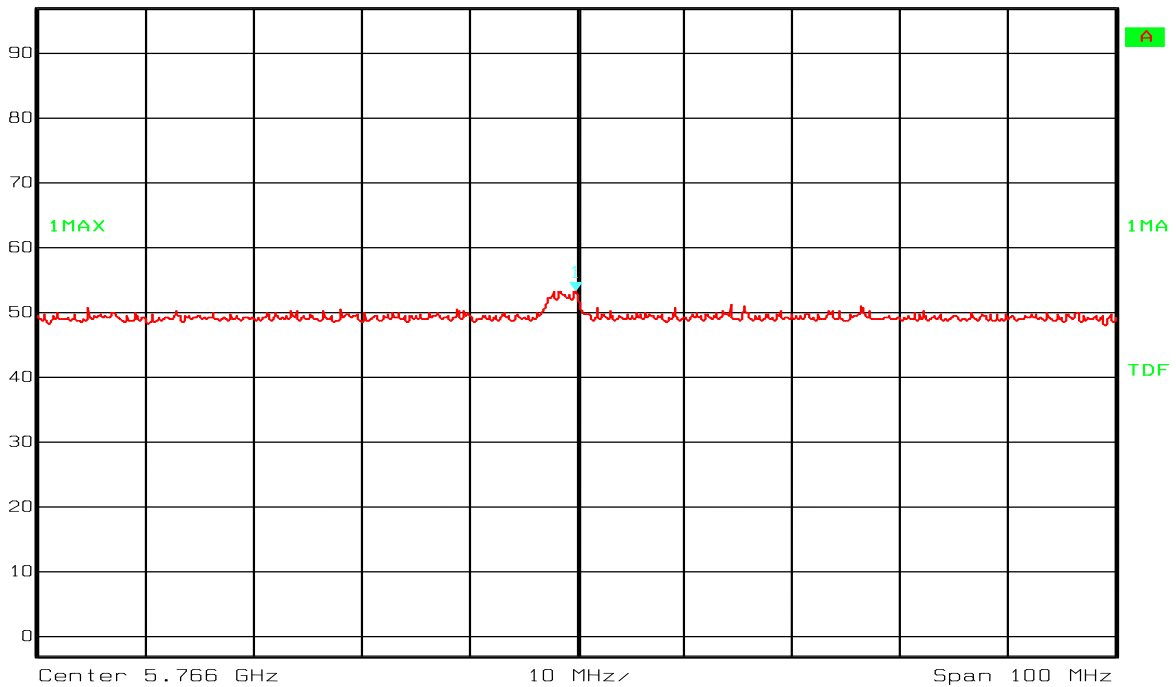

Date: 17.JUL.2006 8:39:17

Spurious Emissions 5.76 GHz (Third Harmonic)

	Ref Lvl	Marker 1 [T1]	RBW	1 MHz	RF Att	0 dB
	97 dB*	54.87 dB μ V/m	VBW	1 MHz		
		7.66486974 GHz	SWT	5 ms	Unit	dB μ V/m

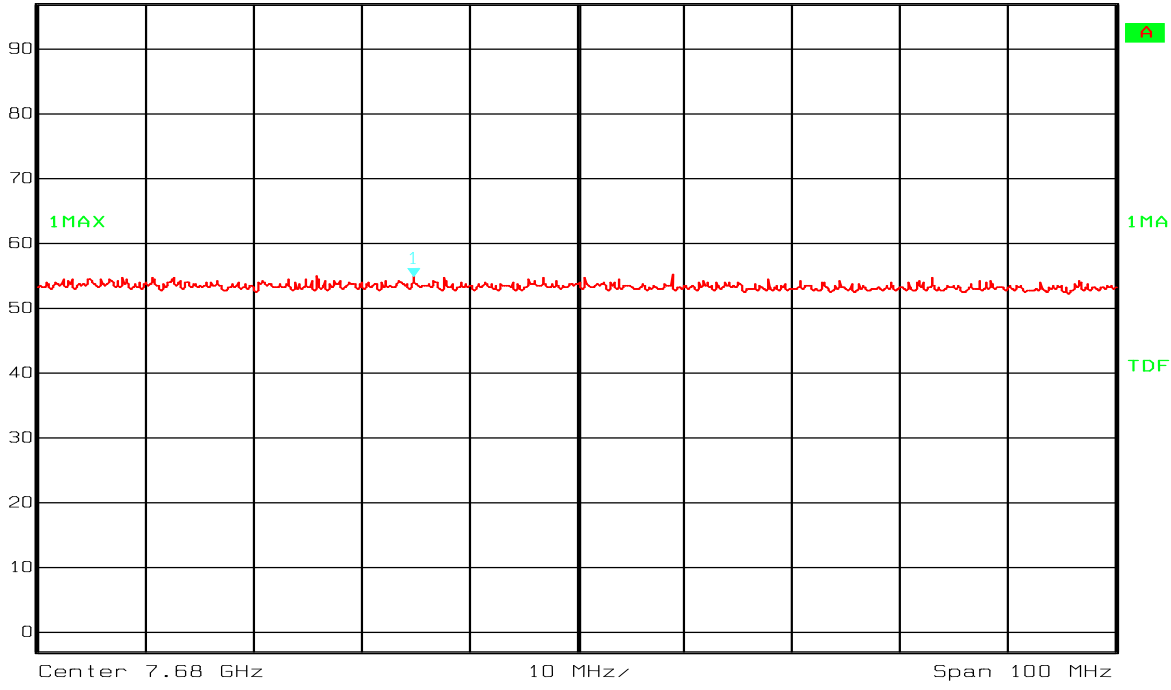

Date: 17.JUL.2006 8:41:41

Spurious Emissions 7.66 GHz (Fourth Harmonic)

	Ref Lvl	Marker 1 [T1]	RBW	1 MHz	RF Att	0 dB
	97 dB*	57.06 dB μ V/m	VBW	1 MHz		
		9.60771543 GHz	SWT	5 ms	Unit	dB μ V/m

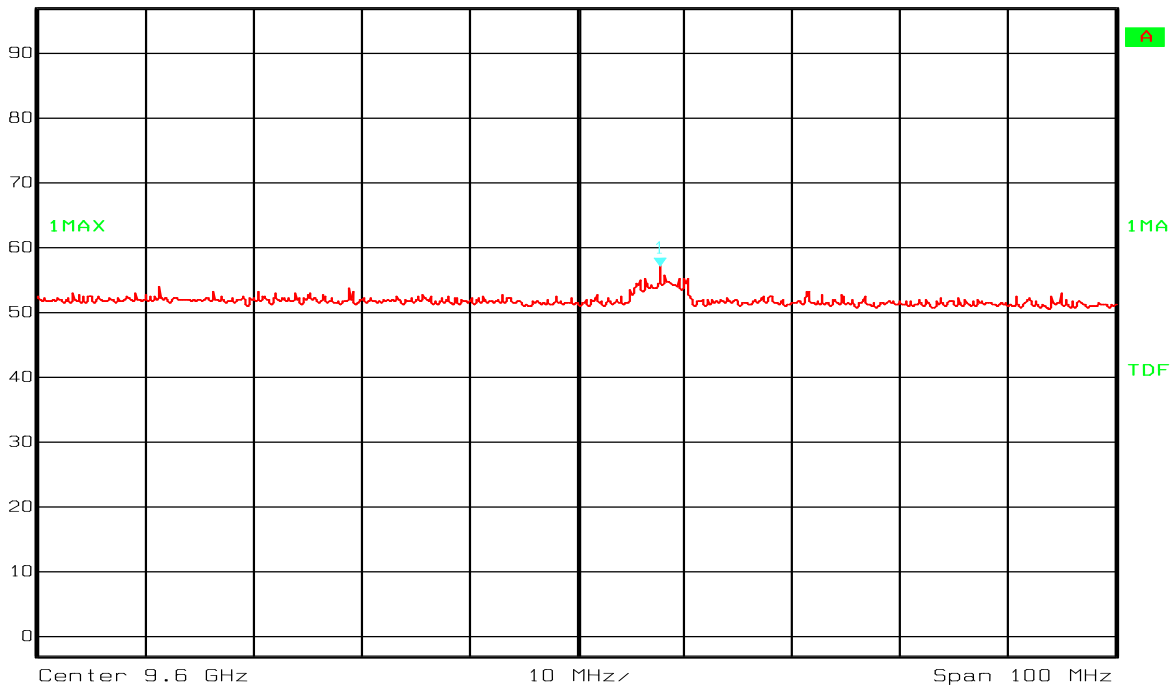

Date: 17.JUL.2006 8:08:22

Spurious Emissions 9.60 GHz (Fifth Harmonic)

	Ref Lvl	Marker 1 [T1]	RBW	1 MHz	RF Att	0 dB
	97 dB*	58.49 dB μ V/m	VBW	1 MHz		
		11.52929860 GHz	SWT	5 ms	Unit	dB μ V/m

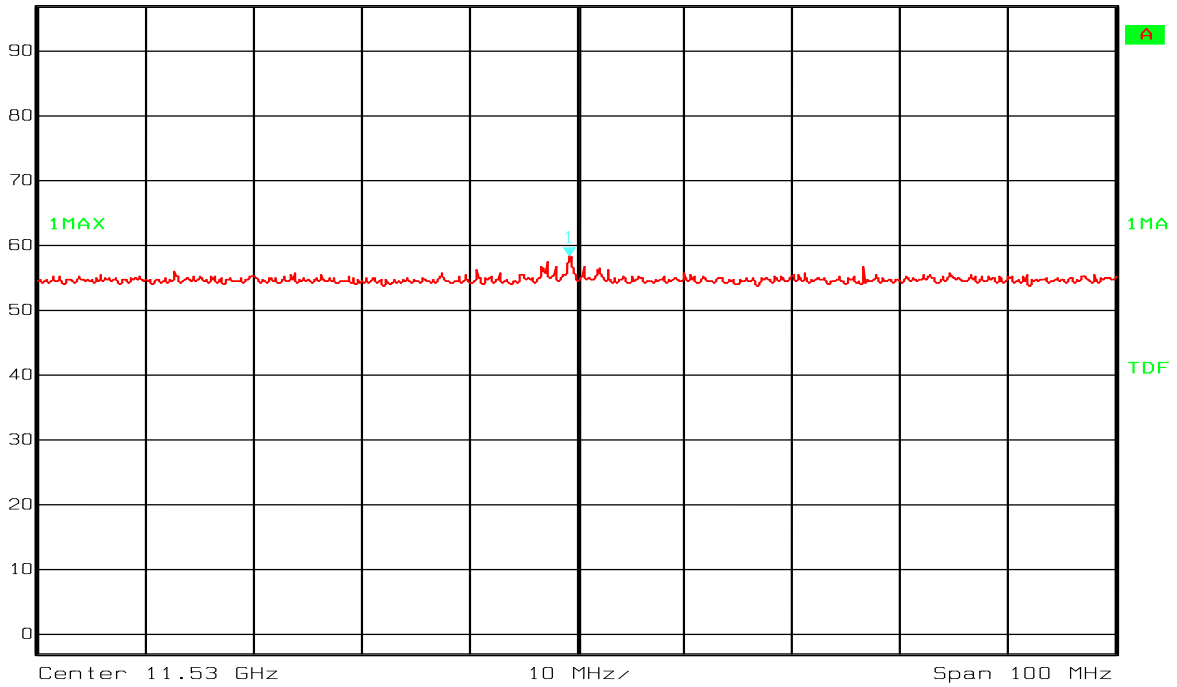

Date: 17.JUL.2006 8:14:16

Spurious Emissions 11.53 GHz (Sixth Harmonic)

	Ref Lvl	Marker 1 [T1]	RBW	1 MHz	RF Att	10 dB
	107 dB*	56.79 dB μ V/m	VBW	1 MHz		
		19.65531062 GHz	SWT	11.5 ms	Unit	dB μ V/m

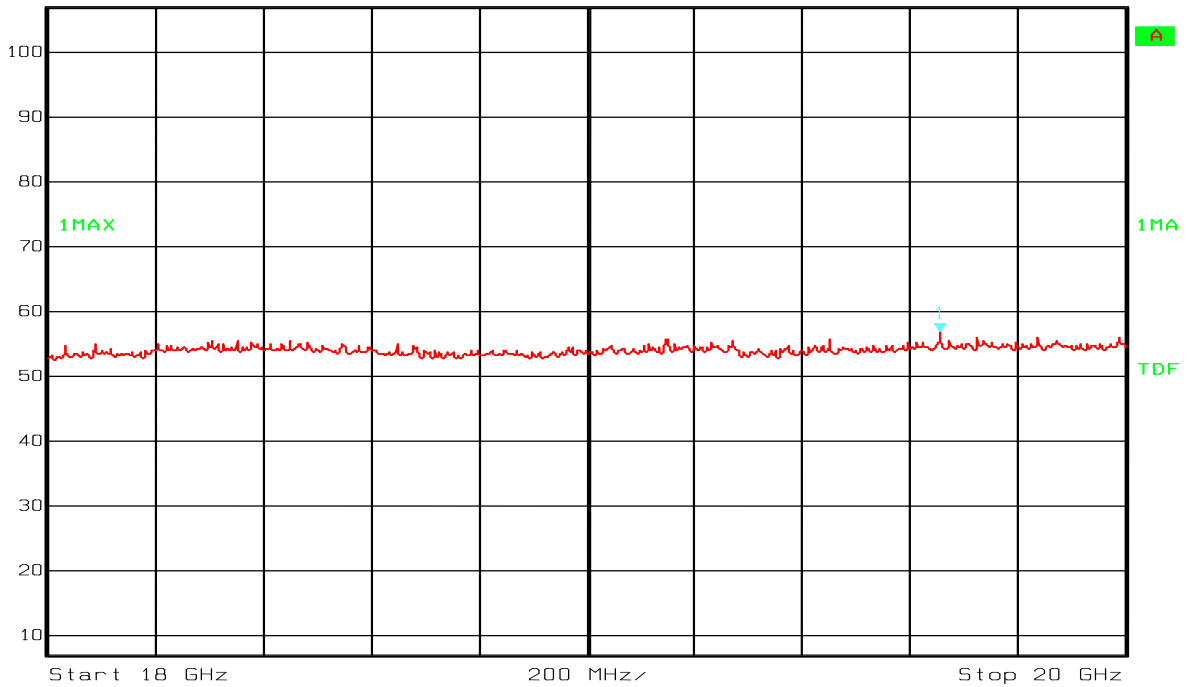

Date: 18.JUL.2006 13:30:36

Spurious Emissions 18 - 20 GHz

4.25 Receiver Spurious Emissions

Measurement Procedure:

Industry Canada RSS-213 paragraph 6.8 and RSS-GEN paragraphs 4.8 and 6.

Test results:

The Receiver Spurious Emissions are covered by paragraph 4.23 Spurious Emissions Radiated. No separate Spurious Emissions which could be related to the receiver were detected during the radiated test.

5 Test Setups

5.1 Frequency Measurements



Test equipment included: 5

Test Set-up 1

This setup is used for measuring Carrier frequency stability at normal and extreme temperatures.

5.2 Timing Measurements

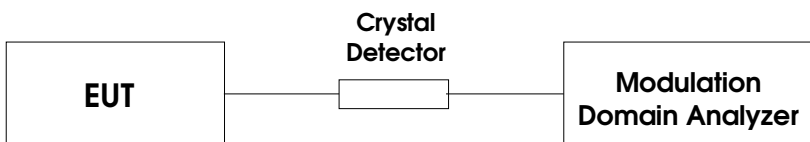

Test equipment included: 5, 7

Test Set-up 2

This setup is used for measuring Frame repetition stability, Frame period and Jitter.

5.3 Conducted Emission Tests

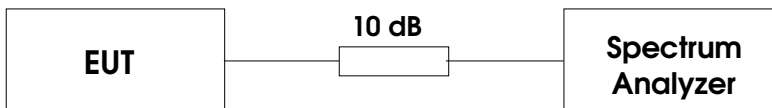

Test equipment included: 1, 13

Test Set-up 3

This setup is used for all conducted emission tests.

5.4 Radiated Emission Tests

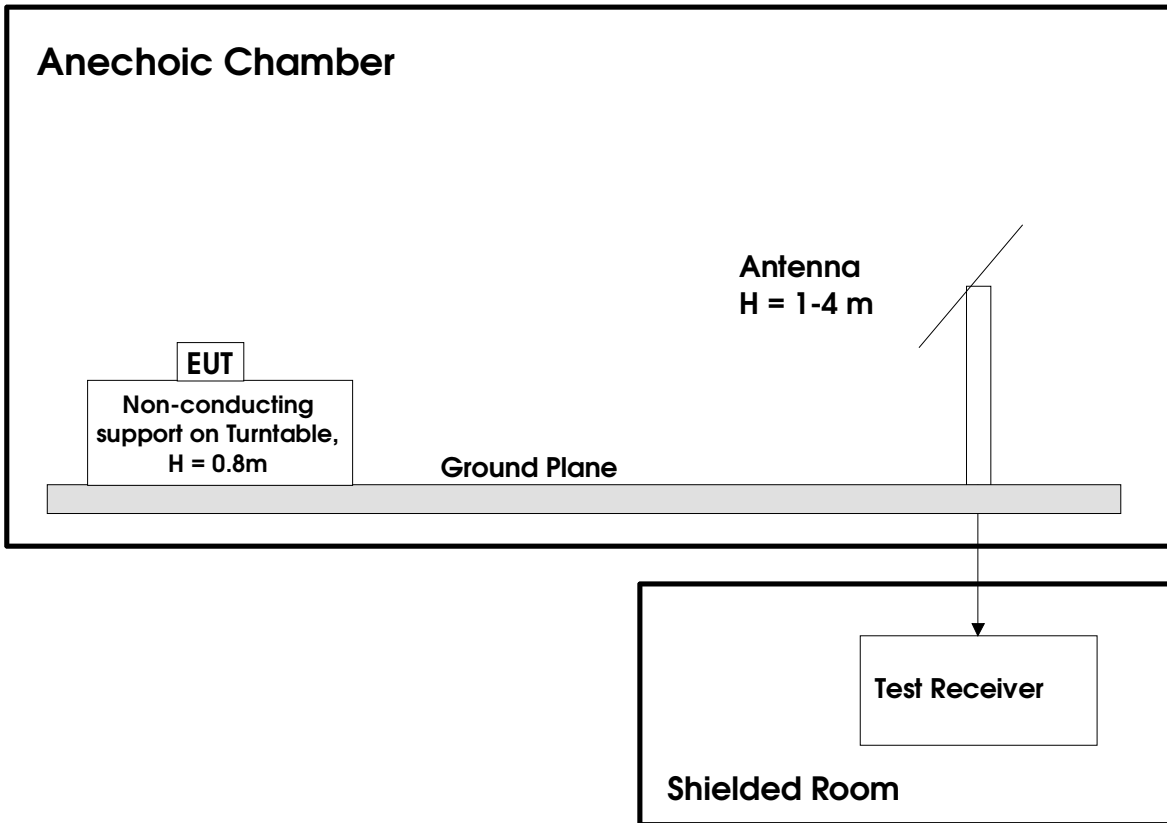

Test equipment: 1, 8, 9, 10, 11, 20, 21, 22, 23, 24, 25, 26

Test Set-Up 4

This test setup is used for all radiated emissions tests. For frequencies below 30 MHz the measuring distance is 10 m, for all other frequencies it is 3m or 1m. Emissions above 1 GHz were measured with a Spectrum Analyzer and Horn Antenna and with the preamplifier after the antenna. For measurements above 18 GHz the test receiver is moved inside the anechoic chamber and located next to the antenna to minimize the cable loss.

5.5 Power Line Conducted Emissions Tests

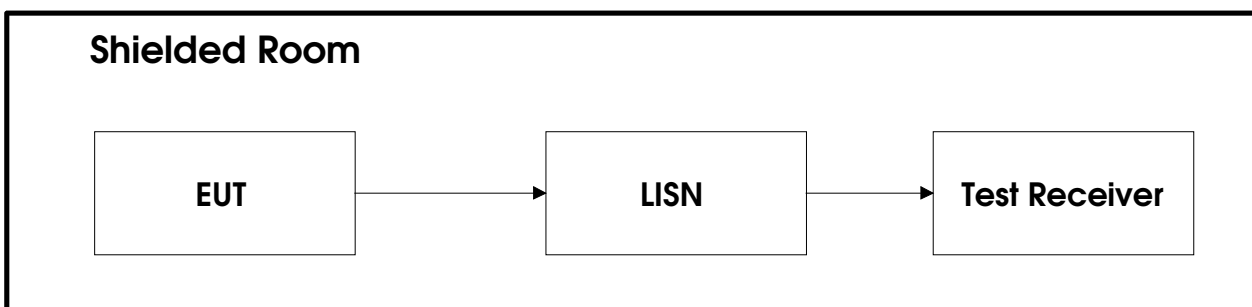

Test equipment: 12, 27, 28

Test Set-Up 5

5.6 Monitoring Tests

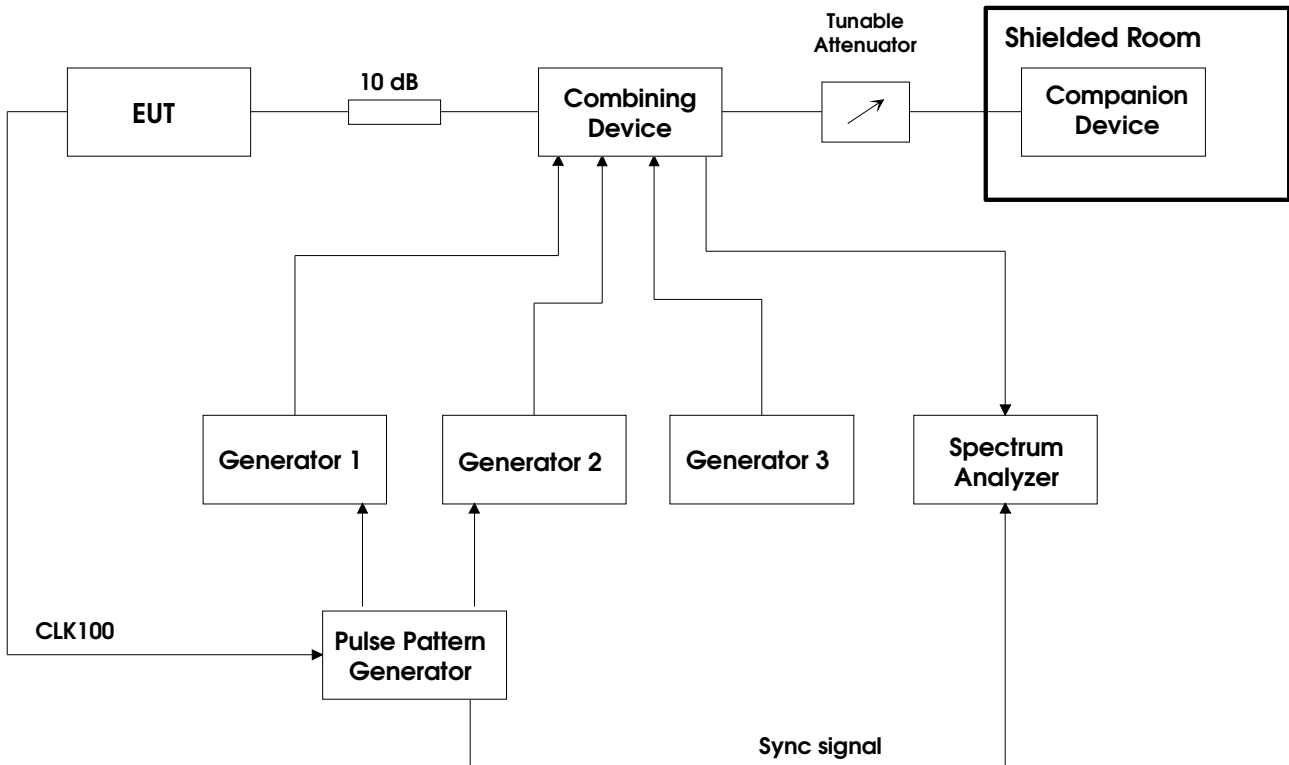

Test equipment: 1, 2, 3, 4, 6, 13, 14, 15, 16, 17, 18, 19

Test Set-Up 6

This test setup is used for all Monitoring and Time and Spectrum Access Procedure tests. The path loss from the signal generators to the EUT are measured with a power meter before the testing is started.

The CLK100 is used to synchronize the Pulse-/ Pattern generator to the start of the DECT frame, this signal always comes from the base station. If the EUT is a DECT Portable Part (i.e. a handset) the CLK100 signal will come from the Companion Device.

The sync signal to the Spectrum Analyzer is the CLK100 signal that is regenerated in the Pulse-/ Pattern Generator, this is used to synchronize the Spectrum Analyzer to the DECT frame when in zero span. The Pulse-/ Pattern Generator is used for tests that require time synchronized pulses or blocking of specific time slots.

6 Test Equipment Used

To facilitate inclusion on each page of the test equipment used for related tests, each item of test equipment and ancillaries are identified (numbered) by the Test Laboratory.

No.	Instrument/ancillary	Type of instrument/ancillary	Manufacturer	Ref. no.
1	FSEK30	Spectrum Analyzer	Rohde & Schwarz	LR 1337
2	SME03	Signal generator	Rohde & Schwarz	LR 1238
3	SMP04	Signal generator	Rohde & Schwarz	LR 1336
4	SMHU52	Signal generator	Rohde & Schwarz	LR 1240
5	53310A	Modulation Domain Analyzer	Hewlett Packard	LR 1483
6	81104A	Pulse-/ Pattern Generator	Agilent	LR 1502
7	8470B	Crystal Detector	Hewlett Packard	LR 1207
8	8449B	Preamplifier	Hewlett Packard	LR 1322
9	4HC3000/18000	Highpass filter	Trilithic	S.No.: 9849045
10	ESVS30	Measuring Receiver	Rohde & Schwarz	LR 1101
11	ESN	Measuring Receiver	Rohde & Schwarz	LR 1237
12	ESAI	Measuring Receiver	Rohde & Schwarz	LR 1090
13	6810.17B	Attenuator	Narda	LR1212
14	745-69	Step Attenuator	Narda	LR 1442
15	WE 1506A	Power Splitter	Weinchel	LR 244
16	WE 1506A	Power Splitter	Weinchel	LR 245
17	H-9	Hybrid	Anzac	LR 86
18	H-9	Hybrid	Anzac	LR 257
19	S212DS	RF Switch	Narda	LR 1244
20	3115	Horn Antenna	EMCO	LR 1330
21	PM 7320X	Horn Antenna	Sivers Lab	LR 103
22	DBF-520-20	Horn Antenna	Systron Donner	LR 101
23	638	Horn Antenna	Narda	LR 1480
24	HL223	Biconical Antenna	Rohde & Schwarz	LR 1261
25	HK116	Logperiod Antenna	Rohde & Schwarz	LR 1260
26	HFH2-Z2	Loop Antenna	Rohde & Schwarz	LR 285
27	ESH3-Z5	Two Line V-Network	Rohde & Schwarz	LR 1076
28	80S	Signal Generator	Powertron	LT 502