

Transmitter Schematic Diagram

Figure 5.2.1.1.

FCC ID# BRWXS3

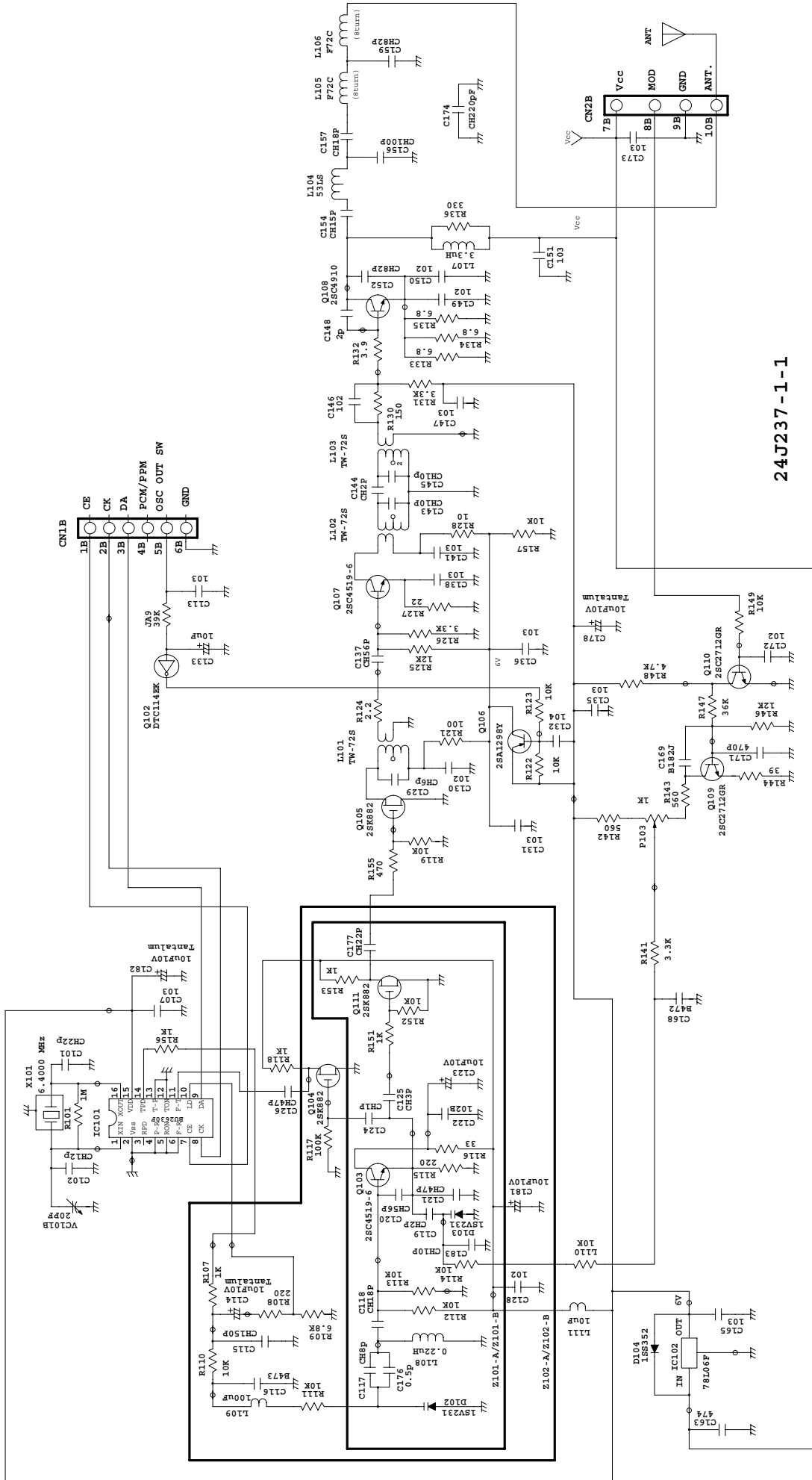

24J237-1-1

Transmitter Schematic Diagram

Figure 5.2.2.

FCC ID# BRWXS3