

Technical Report
Transmitter Model XS3
FCC ID# BRWXS3

T A B L E O F C O N T E N T S

1.0 INTRODUCTION

- 1.1 Definition
- 1.2 Application
- 1.3 Construction

2.0 ENCODER THEORY OF OPERATION

3.0 THEORY OF OPERATION

- 3.1 General
- 3.2 Block Diagram

4.0 FAILURE ANALYSIS

5.0 APPENDICES

- 5.1 Transmitter Block Diagram
- 5.2 Transmitter Schematic Diagram
- 5.3 Transmitter Photographs and ID Labels
- 5.4 Transmitter Tune-Up Procedure
- 5.5 Quarts Crystal Specifications
- 5.6 Test Data

Technical Report
Transmitter Model
FCC ID# BRWXS3

1.0 INTRODUCTION

1.1 Definition

The Model XS3 is a transmitter for the Remote Control (R/C) of models such as cars, boats, etc.

This Transmitter is for FM PLL System, available for the PPM (Pulse Position Modulation).

This Transmitter is a part of the HORIZON HOBBY DISTRIBUTORS, INC. PPM "family" of Remote Control Transmitters which at this time consists of:

Transmitter Model #	FCC ID #
XR-3	BRWXR-3
XR3i	BRWXR3i

Separate Applications for each transmitters and for the receivers are submitted as required by the Commission.

The Manufacturer, Japan Remote Control Company (JR), manufactures all transmitters and receivers. The PPM family of R/C systems is exported by JR to the United States of America, and several European and Asian Countries.

The Applicant for this Equipment Authorization, HORIZON HOBBY DISTRIBUTORS, INC. will, following receipt of Grant of Equipment Authorization, import only those versions of these R/C radios which are allowed for use in the USA under the Rules and Regulations of the Federal Communications.

The 75 - 76 MHz version of this transmitter is the subject of this Application; these are the units which will be offered for sale to the general public.

Technical Report
Transmitter Model XS3
FCC ID# BRWXS3

1.2 Application

The Model XS3 R/C transmitter utilizes " Phase Locked Loop "and " Frequency Modulation "to convey the PPM encoded position of its control handle and trigger switches to its companion R/C receiver, where the PPM encoded pulse train is demodulated, decoded, and supplied to a number of servo-mechanisms for positioning of control surfaces, throttle etc. on the model.

The Frequency-Shift-Keying of the transmitter carrier takes place in the rhythm of the PPM pulse train.

Both transmitter and receiver are very narrow band units; they have been designed to comply with the European requirements of 10 KHz channel spacing.

1.3 Construction

The Model XS3 Transmitter all consists of a plastic case.

(Reference is made to Fig. 5.1, Transmitter Block Diagram)

- * control handle and trigger
- * a 8sells dry battery
- * an analog-to-digital converter (ADC)
- * a microprocessor to create the PPM pulse train
(M38C24M4)
- * a Phase Locked Loop stage
- * a modulator driver stage
- * a RF power stage
- * a telescopic antenna

This Transmitter is to be made available by the importer only on those carrier frequencies in the 75 - 76 MHz frequency band which are at present authorized for R/C use.

Technical Report
Transmitter Model XS3
FCC ID# BRWXS3

2.0 ENCODER THEORY OF OPERATION

Reference is made to Figure 5.1, Transmitter Block Diagram.

The functions of the encoder are to:

- * accept the analog voltages from the control inputs (handle and trigger).
- * process the analog voltages to create control mixing, adding, reversing, etc., as desired by the user.
- * sample these voltages in a cyclic rhythm under control of the system's internal timing generator.
(This process is called commutation.)
- * process these analog voltages into binary weighted digital control words by means of an Analog-to-Digital Converter (ADC).
- * store these digital representations of the analog control input into a temporary memory (RAM).
- * supply this serial data stream to a buffer-driver for modulation of the RF Transmitter.
- * provide "housekeeping" of the encoding process by means of a quartz crystal controlled internal clock.
- * provide supply voltages to the RF section ($V_{cc} = 12V$ battery voltage).

The entire program which controls the timing housekeeping, parallel-to-serial conversion process, and insertion of synchronization words and error detection codes is governed by a Central Processing Unit (CPU) under control by an internally stored program residing in Read-Only Memory (ROM). The CPU, RAM and ROM are all part of a single-chip microprocessor.

Resolution of the Analog-to-Digital conversion process is nine (9) bits for a control accuracy of $1:2^9$

Technical Report
 Transmitter Model XS3
 FCC ID# BRWXS3

3.0 THEORY OF OPERATION

3.1 General

Reference is made to Figure 5.1, Transmitter Block Diagram.

The HORIZON HOBBY DISTRIBUTORS, INC. Model XS3 R/C Transmitter is handle and trigger type Transmitter.

It operates on any of the R/C frequency (Channels) allowed by the Commission in the 75 -76 MHz frequency band. Selection of the desired RF channel is made by PLL frequency data.

This transmitter employs Frequency-Sift-Keying (FSK) of the carrier frequency, whereby the output frequency is either low or high due to the symmetrical FSK modulation process, the (center) output frequency cannot be directly measured, but must be calculated by taking the average of the high and low frequency states.

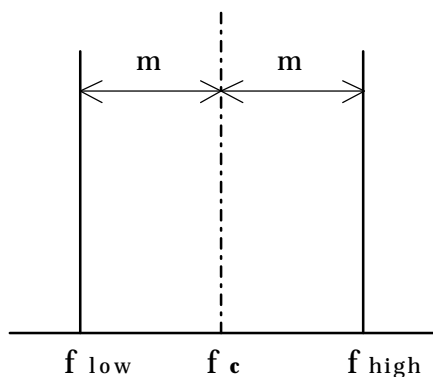

m = shift from center frequency
 (m = approx. 1.8 KHz)

$$f_{\text{center}} = \frac{f_{\text{low}} + f_{\text{high}}}{2}$$

The peak-to-peak deviation of the FSK signal is approximately 3.6 KHz ("sliver modulation")

Because of the unfamiliarity of the general public with the term FSK, this modulation technique is commonly named FM.

Technical Report
Transmitter Model XS3
FCC ID# BRWXS3

3.2 Block Diagram

(Reference is made to Figure 5.1)

The (up to) two control potentiometers are at the left side of the schematic drawing.

The control potentiometer, which is mechanically coupled to the control handle and trigger, is supplied with the regulated 5.0V voltage. The wiper on this pot is exactly centered in the neutral control stick position. All analog processing is performed as deviations from this center (reference) voltage.

After the mixing of each channel, control voltage is changed to Pulse Train, through encoder circuit.

The Q103(2SC4519) is an LC-type VCO(Voltage Controlled Oscillator), which is designed to oscillate with about 75.69MHz. Its output is led to amplifying stage for transmitting through a buffer(Q111), while it is also led to the PLL through a buffer(Q104). The pulses generated by the CPU are transferred to the VCO so as to modulate the radio wave. this part is strictly shielded from electric/magnetic noise.

The IC101(BU2630) is a PLL(phase Lock Loop). Exact 6.4MHz is generated by an internal crystal oscillator, and divided by 2,560 for 2.5kHz. VCO wave is also divided by a definite number, which is 30,276 in case of 75.690MHz, for getting 2.5kHz. Two 2.5kHz's are compared in the phase and the VCO is so controlled that the error gets minimum, while the modulation is so fast that the filter between the PLL and the VCO cancels an error fluctuation.

Frequency data is stored in the IC1(M38C24M4/CPU) as an above-mentioned dividing number, and transferred to the PLL as the serial data while the transmitter is in normal operation mode. Frequency data can be changed only in system set-up mode with the power of the RF section being cut. Directly after it has turned on normally, though the CPU starts sending the PLL the data, the radio wave is still silent because the RF amplifier (Q105, Q107) is not supplied with the power yet. After a while, certain stabilizing time for the PLL, the Q102(DTC114) and Q106(2SA1298) starts to supply them with the power so that the radio wave is transmitted.

Q107 drives the Power Amplifier (PA).

The straight-through PA stage(Q108) is followed by a matching and band pass/low-pass network. This network matches the low PA stage output impedance to the whip antenna.

Technical Report
Transmitter Model XS3
FCC ID# BRWXS3

DC Supply Voltage enter the RF section: 12Volt "law" battery voltage supplies the PA stage only. PLL stages, and bias current for all stages, including the PA, are derived from the regulated 6.0 Volt.

4.0 FAILURE ANALYSIS

A failure analysis was conducted to ascertain that single-component failure will not result in unauthorized radiation.

It should be noted that component failure would result in return of the unit to the factory, or to an authorized repair station.

(Reference is made to Figure 5.2, Transmitter Schematic Diagram)

Failure of any of the transistors (predominant failure mode: emitter-collector short) will result in the unit becoming inoperative: In the case of Q103 oscillator short, RF output will be non-existent. Q111, Q105, Q107 or Q108 failure will result in very low, if any, output.

Failure of the MOD IN input (latch at 0 or 12Volt) or modulator transistor Q109, Q110, and varactor diode D103 (open or short) will result in carrier frequency. (carrier frequency = center frequency - 1.1KHz). Although this failure would render the unit inoperative, the frequency tolerance would still fall within the channel bandwidth and tolerance requirements of .002% of 75 MHz = 1.50 KHz.

When PLL circuit is broken, for example, crystal X101 break down, or IC101(BU2630) for PLL is broken, PLL will stop functioning

Technical Report
Transmitter Model XS3
FCC ID# BRWXS3

5.4 Transmitter R.F. Tune-Up Procedure

1. Remove 8 screws from transmitter. Remove PCB assembly.
Put PC assembly on bench, component side up.
2. Refer to transmitter schematic Figure 5.2.2.
Soften bee's wax on cores in L101, L102, L103 and L104.
Using oscilloscope with small 50 ohm loop, starting at L101, adjust these cores for maximum oscilloscope reading.
Repeat this tuning sequence until no further increase in oscilloscope reading can be obtained.
3. Extend the aerial, and adjust L101, L102, L103, L104, L105, L106 (in this order) to get maximum output. Try 2 times.
4. Shorten the aerial, and adjust L105 to make the current minimum.
5. Extend the aerial fully, and adjust L104 to get peak.
6. Adjust the frequency.
First, set up the Spectrum Analyzer.
Level Scale is : Log = 5dB/Div, Center Frequency = 75.690Mhz, Span = 5Khz, RBW = 1Khz, VBW = 1Khz.
Then adjust the Amplitude and Attenuator to the right level.
Then, transmit the frequency Band 75 (75.690Mhz) from the Standard Transmitter. Then store wave form to the Spectrum Analyzer. By using VC101B and P103 in the transmitter, adjust it to make the same wave form.
7. Confirm the power.
8. Using spectrum analyzer with small 50 ohm loop, verify that sub harmonic and harmonic components are at least 50dB below carrier component. Pay special attention to 90MHz and 144 MHz components.
9. Remove PCB assembly from Transmitter. Reapply bee's wax to L101, L102, L103 ,L104 ,L105 and L106. Put PCB assembly back into its case, replace the 2 screws.

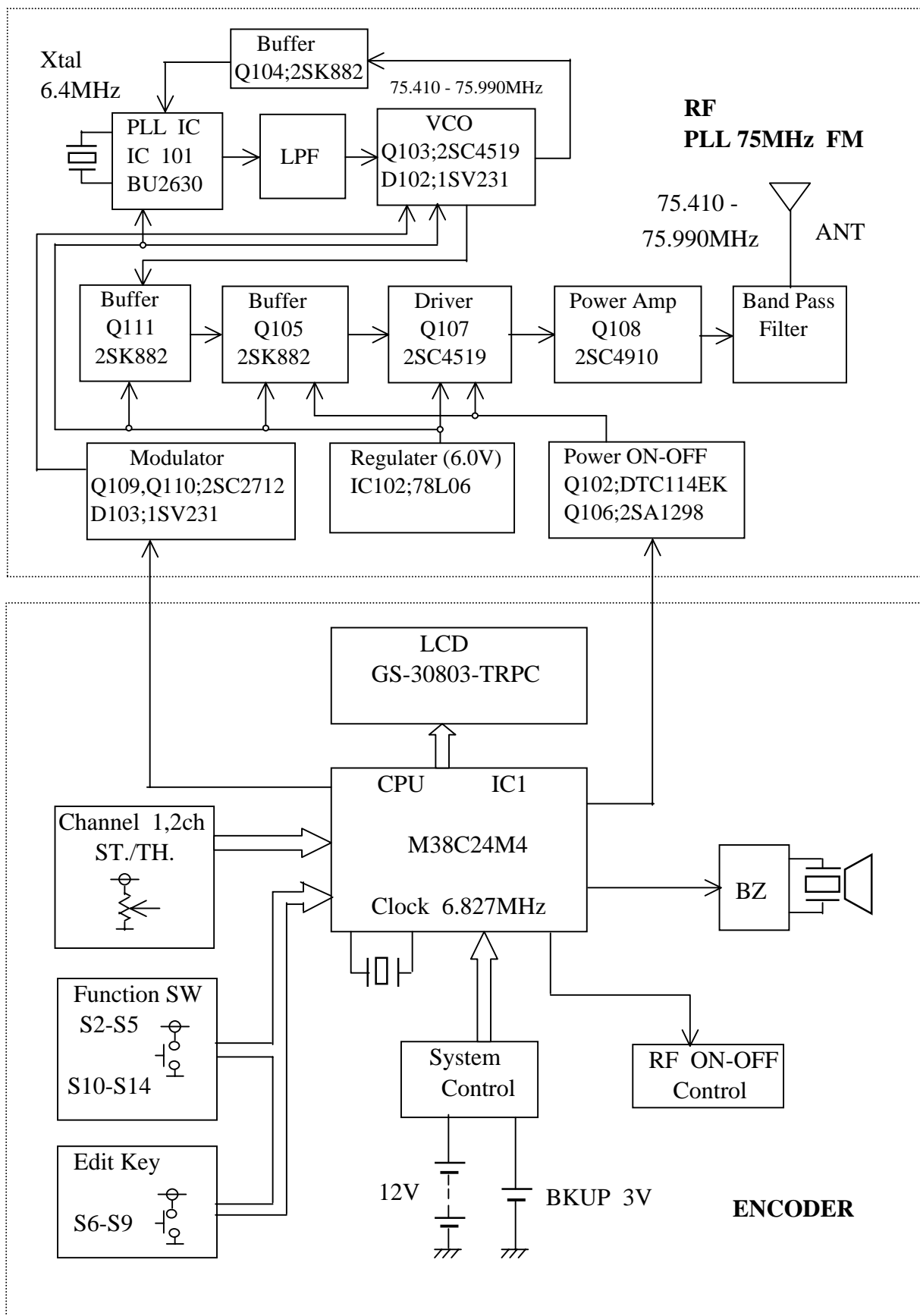

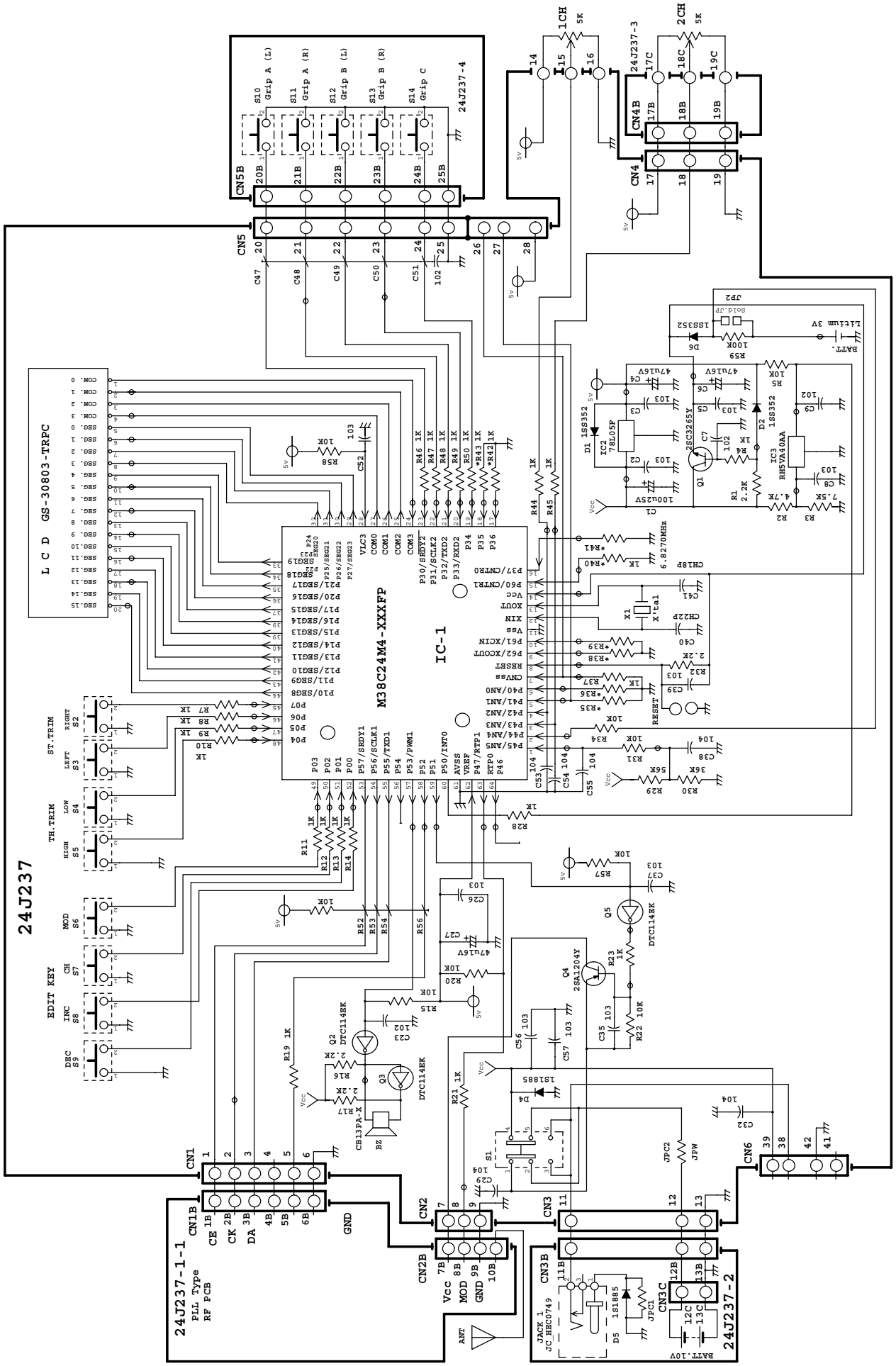

Transmitter Schematic Diagram

Figure 5.2.1.

FCC ID# BRWXS3

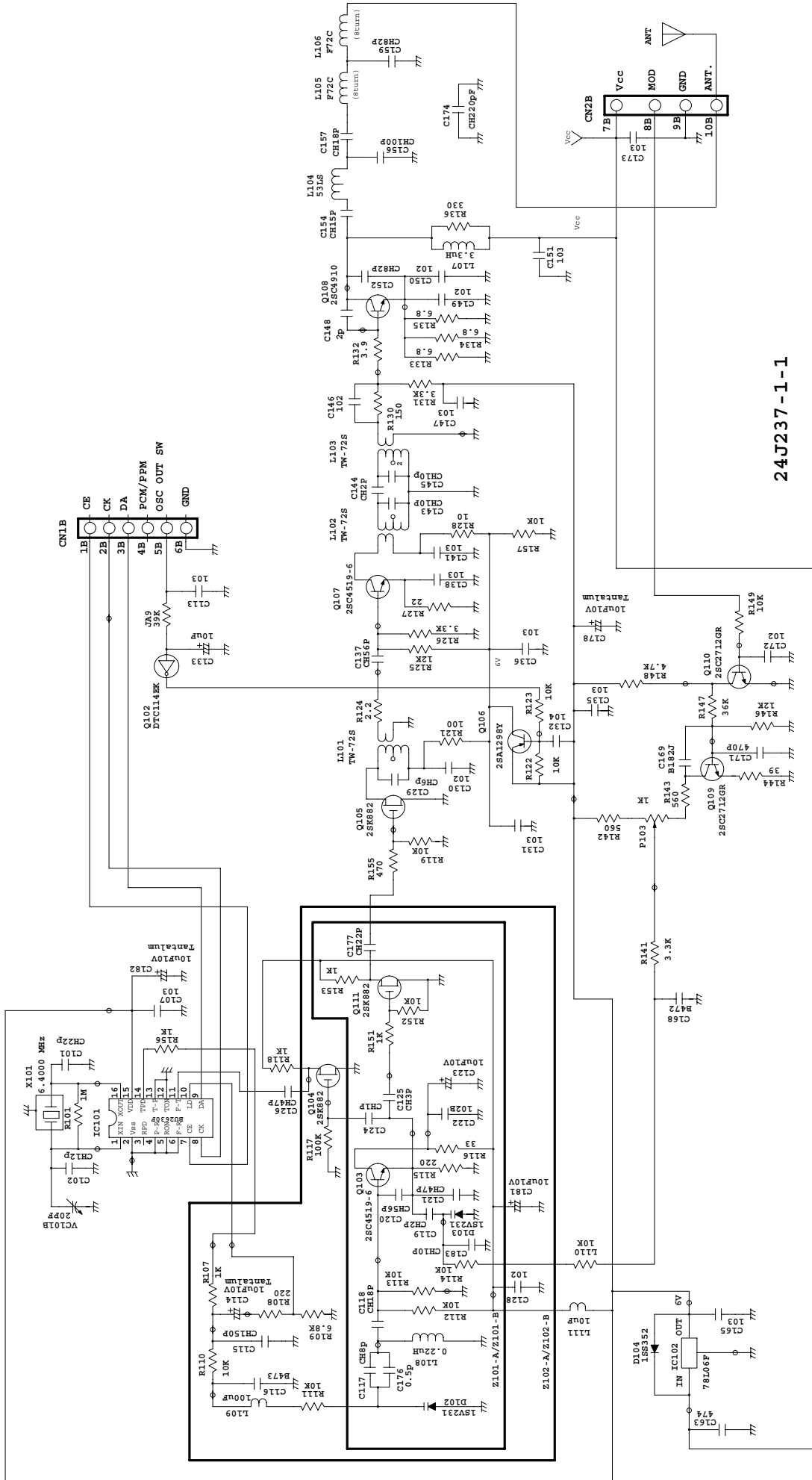

24J237-1-1

Transmitter Schematic Diagram

Figure 5.2.2.

FCC ID# BRWXS3

SPECIFICATION OF CRYSTAL UNIT

1.FREQUENCY	6.400000MHz
2.HOLDER TYPE	HC-49/UT
3.FREQUENCY TOLERANCE	+ - 20 PPM / +25C
4.EQUIVALENT RESISTANCE	30 OHM MAX / SERIES
5.OPERABLE TEMPERATURE RANGE	-20C ----- +60C
6.TEMPERATURE DRIFT	+ - 20 PPM
7.LOADING CAPACITY	12.5 PF
8.DRIVE LEVEL	500 uW
9.SHUNT CAPACITY	7 PF MAX
10.MODE OF OSCILLATION	FUNDAMENTAL
11.INSULATION RESISTANCE	500M OHMS MIN AT 100V DC
12.SHOCK TEST	
	DROPPING FROM 30cm HIGHT 3 TIMES ONFIRM WOOD
	VARIATION : FREQUENCY LESS THAN +5 PPM
	: RESISTANCE LESS THAN + 15 %
13.VIBRATION TEST	
	FREQUENCY 10 TO 55Hz ; AMPLITUDE 1.5mm P-P 1 -2 CYCLE / MINUTES
	TEST TIME 30 MINUTES IN EACH DIRECTION
	VARIATION : FREQUENCY LESS THAN +5 PPM
	: RESISTANCE LESS THAN + 15 %
14.AGING	
	+ - 5 PPM / YEAR

Figure 5.5

Crystal Specification



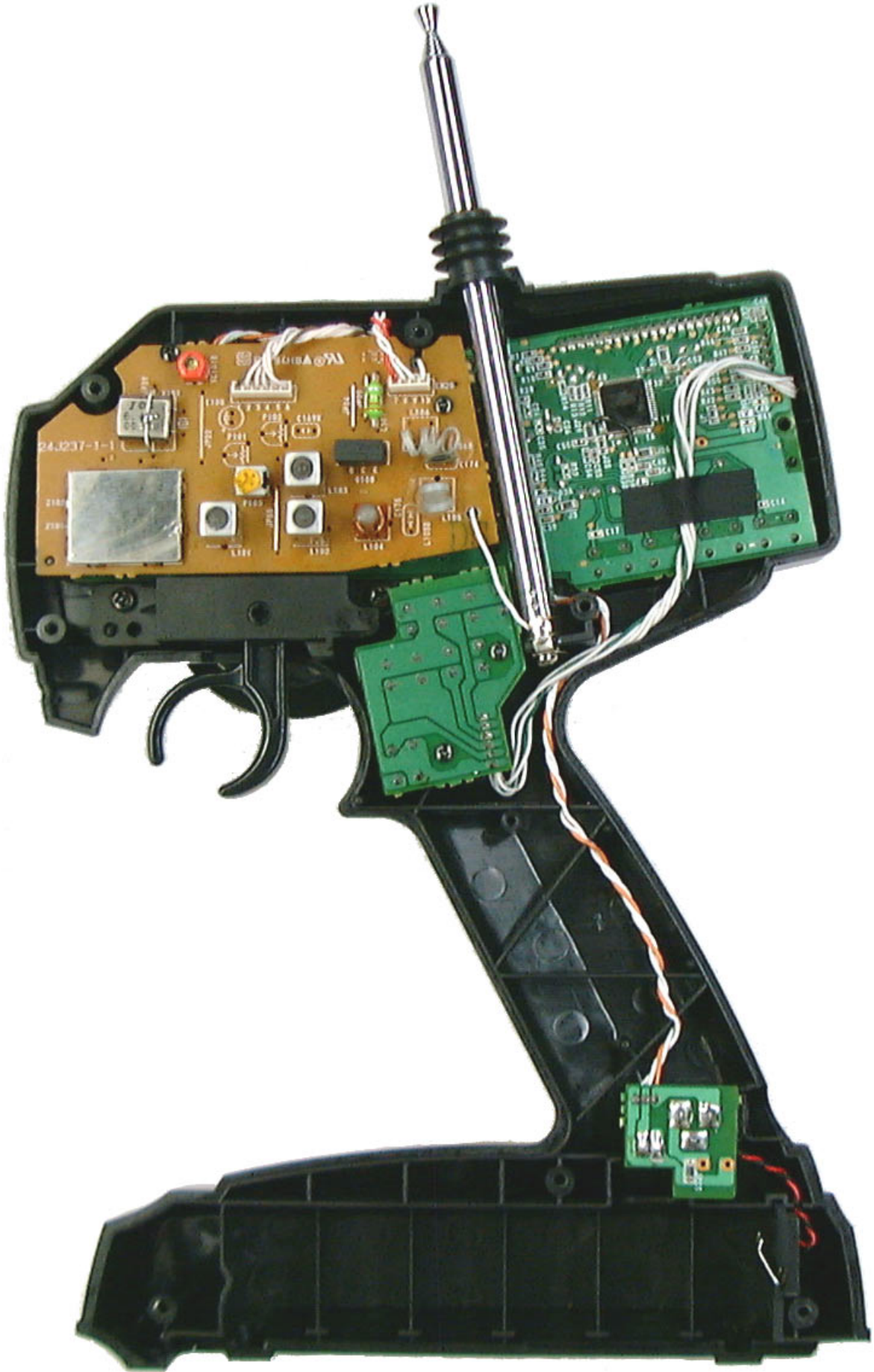



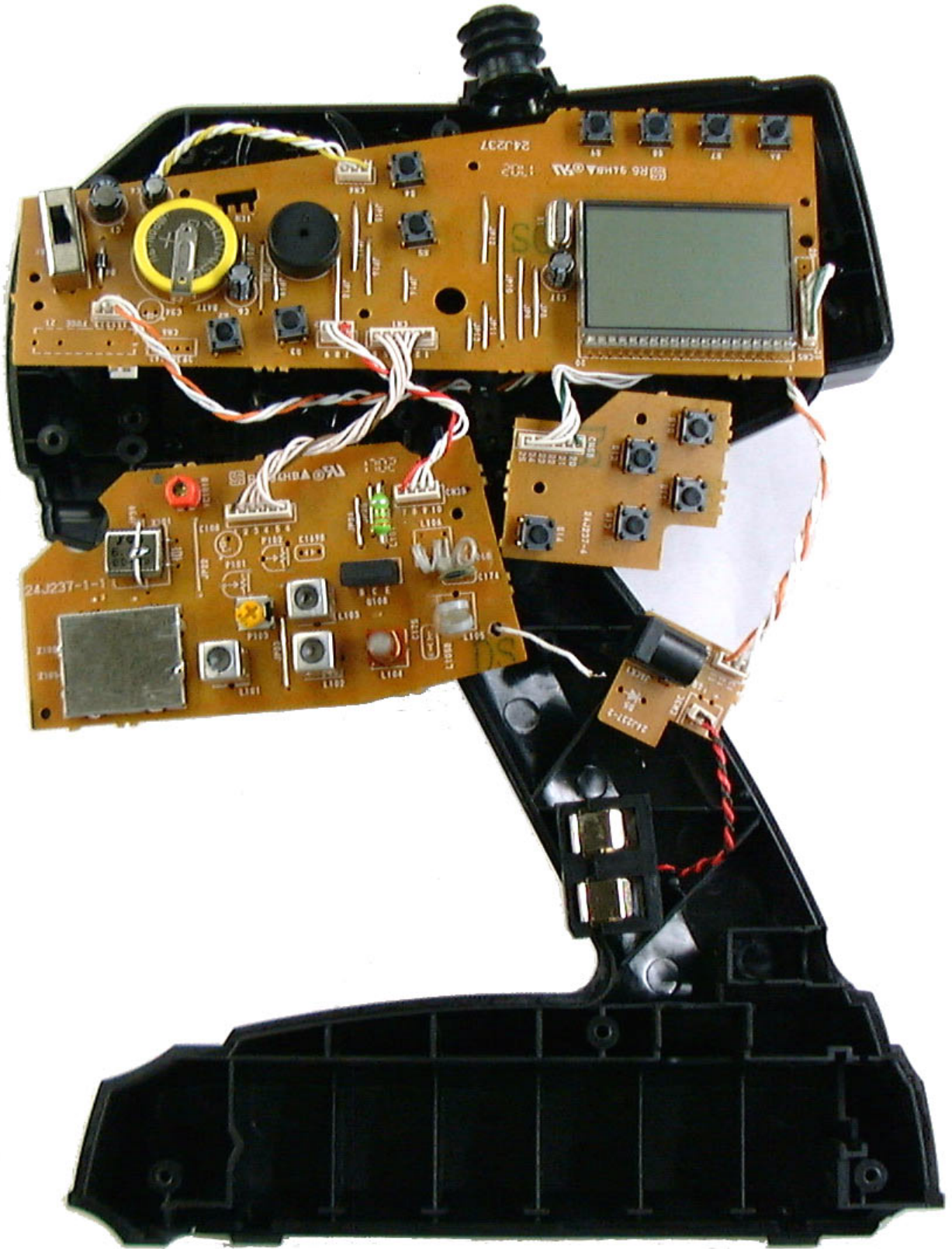





FCC LABEL

FCC ID# BRWXS3