

Technical Report  
Transmitter Model XR2i  
FCC ID# BRWXR2I

T A B L E O F C O N T E N T S

1.0 INTRODUCTION

- 1.1 Definition
- 1.2 Application
- 1.3 Construction

2.0 ENCODER THEORY OF OPERATION

3.0 THEORY OF OPERATION

- 3.1 General
- 3.2 Block Diagram

4.0 FAILURE ANALYSIS

5.0 APPENDICES

- 5.1 Transmitter Block Diagram
- 5.2 Transmitter Schematic Diagram
- 5.3 Transmitter Photographs and ID Labels
- 5.4 Transmitter Tune-Up Procedure
- 5.5 Quarts Crystal Specifications
- 5.6 Test Data

Technical Report  
Transmitter Model XR2i  
FCC ID# BRWXR2I

## 1.0 INTRODUCTION

### 1.1 Definition

The Model XR2i is a transmitter for the Remote Control (R/C) of models such as cars, boats, etc.

This Transmitter is for AM System, available for the PPM(Pulse Position Modulation).

This Transmitter is a part of the HORIZON HOBBY DISTRIBUTORS, INC. AM"family" of Remote Control Transmitters which at this time consists of:

Transmitter Model #	FCC ID #
Beat GEAR NET-102	BRWNET102
NET-112	BRWNET-112
PYTHON	BRWPYTHON

Separate Applications for each transmitters and for the receivers are submitted as required by the Commission.

The Manufacturer, Japan Remote Control Company (JR), manufactures all transmitters and receivers. The AM family of R/C systems is exported by JR to the United States of America, and several European and Asian Countries.

The Applicant for this Equipment Authorization, HORIZON HOBBY DISTRIBUTORS, INC. will, following receipt of Grant of Equipment Authorization, import only those versions of these R/C radios which are allowed for use in the USA under the Rules and Regulations of the Federal Communications.

The 75 - 76 MHz version of this transmitter is the subject of this Application; these are the units which will be offered for sale to the general public.

Technical Report  
Transmitter Model XR2i  
FCC ID# BRWXR2I

## 1.2 Application

The Model XR2i R/C transmitter utilizes "Amplitude Modulation" to convey the PPM encoded position of its control handle and trigger and switches to its companion R/C receiver, where the PPM encoded pulse train is demodulated, decoded, and supplied to a number of servo-mechanisms for positioning of control surfaces, throttle etc. on the model.

Both transmitter and receiver are very narrow band units; they have been designed to comply with the European requirements of 10 KHz channel spacing.

## 1.3 Construction

The Model XR2i Transmitter all consists of a plastic case.

(Reference is made to Fig. 5.1, Transmitter Block Diagram)

- \* control handle and trigger
- \* a 8cells dry battery
- \* an analog-to-digital converter (ADC)
- \* a microprocessor to create the PPM pulse train  
(M38C24M4)
- \* a modulator driver stage
- \* a RF power stage
- \* a telescopic antenna

This Transmitter is to be made available by the importer only on those carrier frequencies in the 75 - 76 MHz frequency band which are at present authorized for R/C use.

Technical Report  
Transmitter Model XR2i  
FCC ID# BRWXR2I

## 2.0 ENCODER THEORY OF OPERATION

Reference is made to Figure 5.1, Transmitter Block Diagram.

The functions of the encoder are to:

- \* accept the analog voltages from the control inputs (handle and trigger).
- \* process the analog voltages to create control mixing, adding, reversing, etc., as desired by the user.
- \* sample these voltages in a cyclic rhythm under control of the system's internal timing generator.  
(This process is called commutation.)
- \* process these analog voltages into binary weighted digital control words by means of an Analog-to-Digital Converter (ADC).
- \* store these digital representations of the analog control input into a temporary memory (RAM).
- \* supply this serial data stream to a buffer-driver for modulation of the RF Transmitter.
- \* provide "housekeeping" of the encoding process by means of a quartz crystal controlled internal clock.
- \* provide supply voltages to the RF section ( $V_{cc} = 12V$  battery voltage;  $V_{reg} = 6.0V$  regulated voltage).

The entire program which controls the timing housekeeping, parallel-to-serial conversion process, and insertion of synchronization words and error detection codes is governed by a Central Processing Unit (CPU) under control by an internally stored program residing in Read-Only Memory (ROM). The CPU, RAM and ROM are all part of a single-chip microprocessor.

Resolution of the Analog-to-Digital conversion process is nine (9) bits for a control accuracy of  $1:2^9$

Technical Report  
Transmitter Model XR2i  
FCC ID# BRWXR2I

### 3.0 THEORY OF OPERATION

#### 3.1 General

Reference is made to Figure 5.1, Transmitter Block Diagram.

The HORIZON HOBBY DISTRIBUTORS, INC. Model XR2i R/C Transmitter is handle and trigger type Transmitter.

It operates on any of the R/C frequency (Channels) allowed by the Commission in the 75 -76 MHz frequency band. Selection of the desired RF channel is made by Quarts crystal.

#### 3.2 Block Diagram

(Reference is made to Figure 5.1)

The (up to) four control potentiometers are at the right side of the schematic drawing.

The control potentiometer, which is mechanically coupled to the control handle and trigger, is supplied with the regulated 5.0V voltage. The wiper on this pot is exactly centered in the neutral control handle and trigger position. All analog processing is performed as deviations from this center (reference) voltage.

After the mixing of each channel, control voltage is changed to Pulse Train, through encoder circuit.

The oscillation is oscillated by Transister Q205 with Third-over-tone, 37.5 MHz then, is dubled by Dobrer Amp. And Transister Q202 and Q203 on 2nd stage to reach 75 MHz. After this, it is amplified by power Amp. Transister Q208, and is supplied to the antenna through band pass filter.

Technical Report  
Transmitter Model XR2i  
FCC ID# BRWXR2I

#### 4.0 FAILURE ANALYSIS

A failure analysis was conducted to ascertain that single-component failure will not result in unauthorized radiation.

It should be noted that component failure would result in return of the unit to the factory, or to an authorized repair station.

(Reference is made to Figure 5.2, Transmitter Schematic Diagram)

Failure of any of the transistors (predominant failure mode: emitter-collector short) will result in the unit becoming inoperative:

In the case of Q205 oscillator short, RF output will be non-existent.

Q202 or Q203 failure will result in very low, if any, output. Failure of Q202 and Q206 will register on the unit's meter which indicates collector current into the PA stage.

Failure of the MOD IN input (latch at 0 or 6.0 Volt) or modulator transistor Q209 or Q210, will result in either the non-modulated or small modulated being transmitted.

Although this failure would render the unit inoperative, the frequency tolerance would still fall within the channel bandwidth and tolerance requirements of .002% of 75 MHz = 1.5 KHz.

Failure of the quartz crystal, X201, will inevitably result in no, or strongly reduced, output.

All other incidental failures will render the unit inoperative and because for return of the transmitter to the service facility.

Technical Report  
Transmitter Model XR2i  
FCC ID# BRWXR2I

#### 5.4 Transmitter R.F. Tune-Up Procedure

1. Remove 8 screws from transmitter. Break seal on case and remove PC assembly. Put PC assembly on bench, component side up.
2. Refer to transmitter schematic Figure 5.2.2  
Soften bee's wax on cores in L202,L203 and L204.  
Starting at L202, adjust these cores for maximum wave form of oscilloscope with small 50 ohm loop and L203,L204,L205,L206 adjust.
3. Repeat step 2.
4. Using spectrum analyzer with small 50 ohm loop, verify that sub harmonic and harmonic components are at least 50 dB below carrier component. Pay special attention to 112.5 MHz and 150 MHz components.
5. Remove PC assembly from Transmitter. Re-apply bees wax to L202,L203,L204,L205 and L206.  
Put PC assembly back into its case, replace the four screws and re-seal opposite edge...

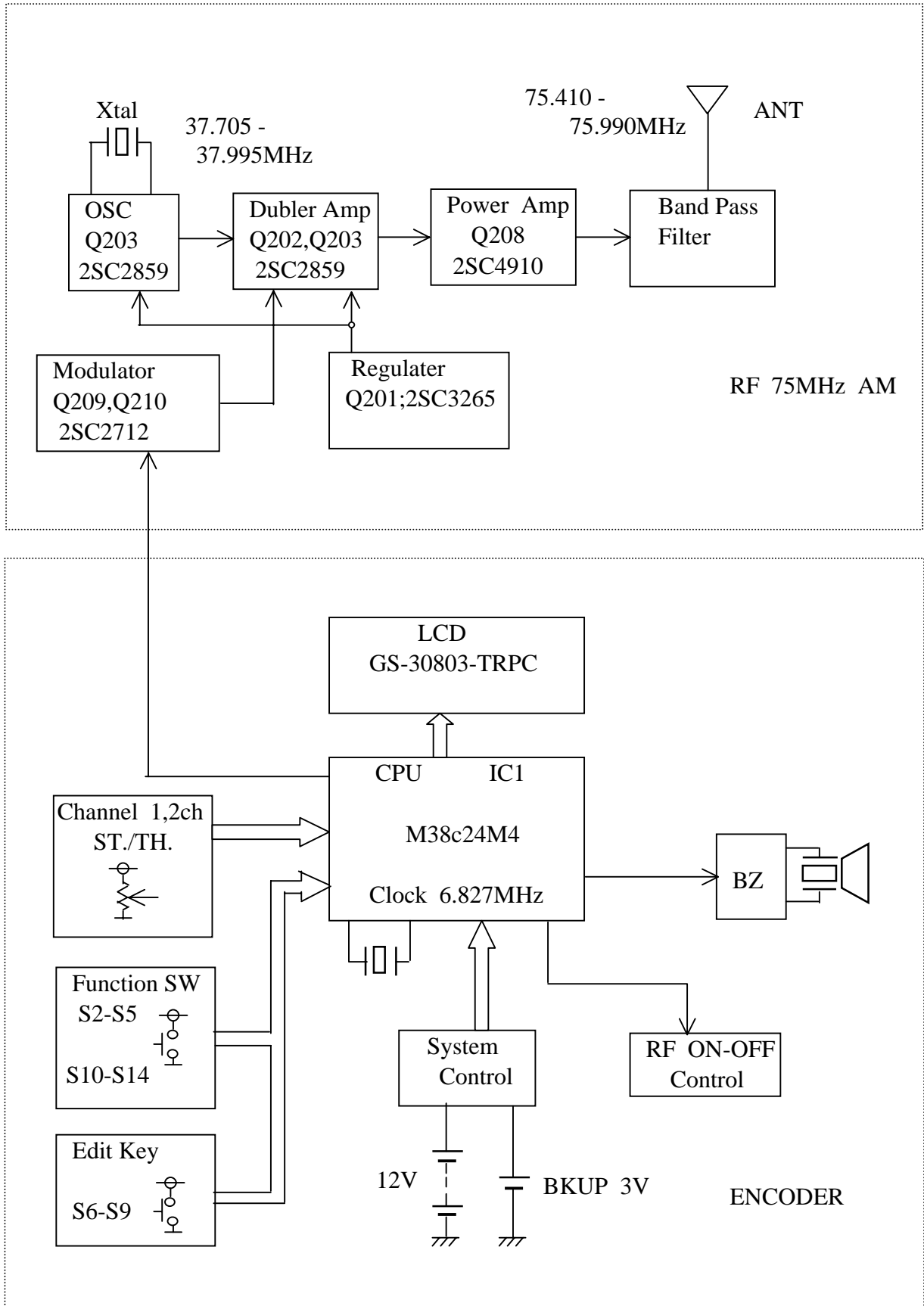



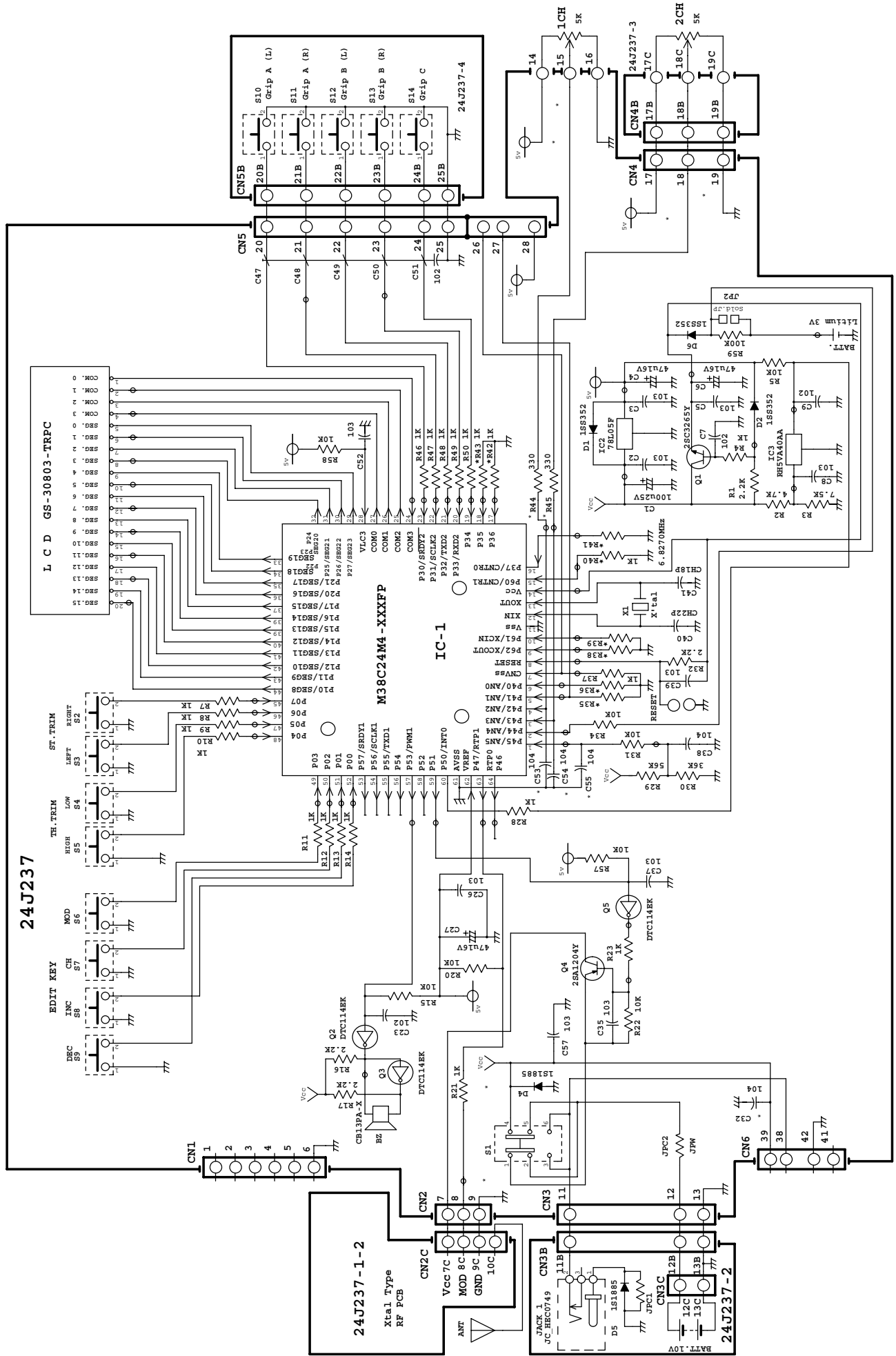

FCC ID# BRWXR21 Transmitter Schematic Diagram Figure 5.2.1.

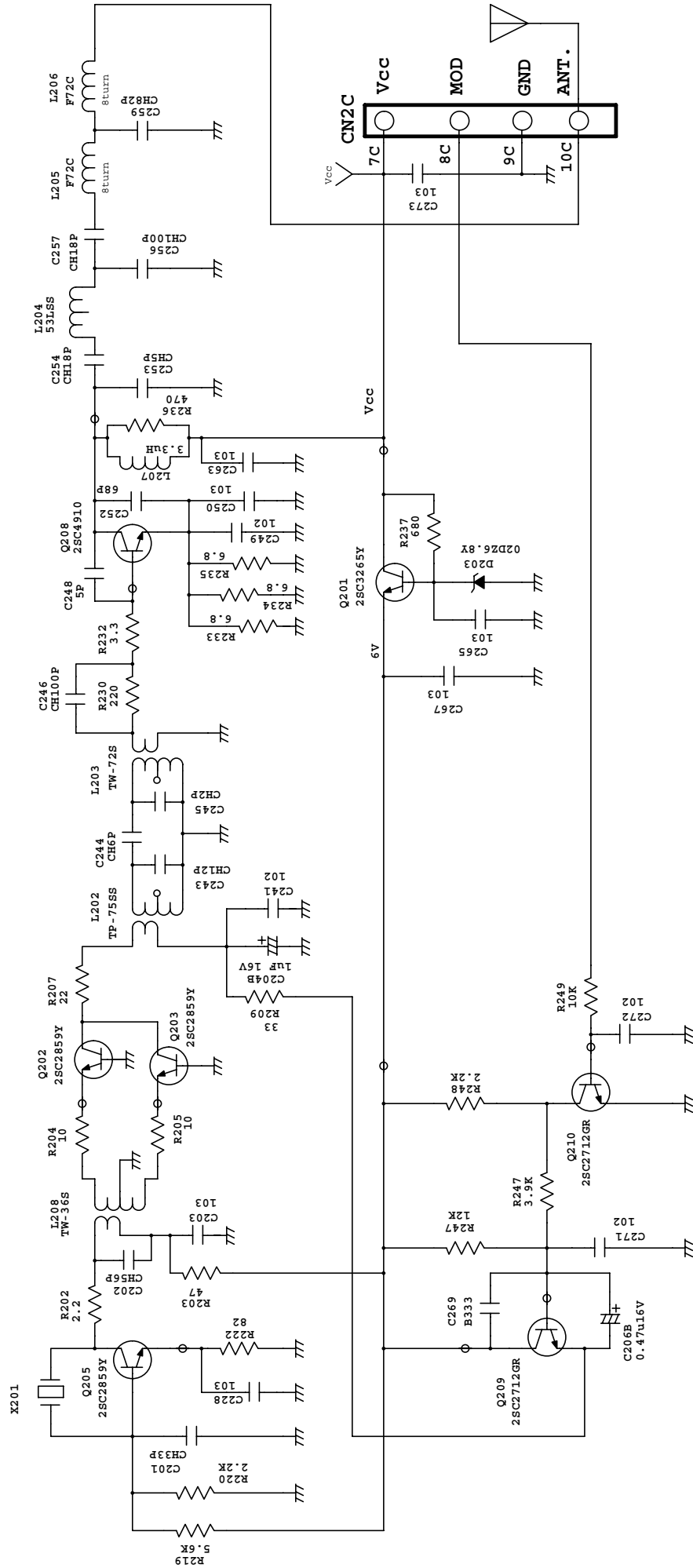

Figure 5.2.2. Transmitter Schematic Diagram

FCC ID# BRWXR2I

SPECIFICATION OF CRYSTAL UNIT

1.FREQUENCY	36MHz (72MHz) TX
2.HOLDER TYPE	HC-50/U
3.FREQUENCY TOLERANCE	+ - 15 PPM/ +25C.
4.EQUIVALENT RESISTANCE	35 OHMS MAX/SERIES
5.OPERABLE TEMPERATURE RANGE	-20 C. ----- +60 C.
6.TEMPERARURE DRIFT	+ - 20 PPM
7.LOADING CAPACITY	20 PF -300Hz=0
8.DRIVE LEVEL	1 mW
9.SHUNT CAPACITY	7 PF MAX
10.MODE OF OSCILLATION	3RD OVERTONE (AT CUT)
11.INSULATION RESISTANCE	500 M OHMS MIN AT 100 V DC
12.SHOCK TEST	

DROPPING FROM 75 CM HEIGHT 3 TIMES ON FIRM WOOD

VARIATION : FREQUENCY LESS THAN +-5 PPM

RESISTANCE LESS THAN +-15 %

13.VIBRATION TEST

FREQUENCY 10 TO 55Hz; AMPLITUDE 1.5mmP-P 1 CYCLE/MINUTES

TEST TIME 120 MINUTES IN EACH DIRECTION

VARIATION : FREQUENCY LESS THAN +-5 PPM

RESISTANCE LESS THAN +-15 %

14.AGING

+ - 5 PPM/YEAR



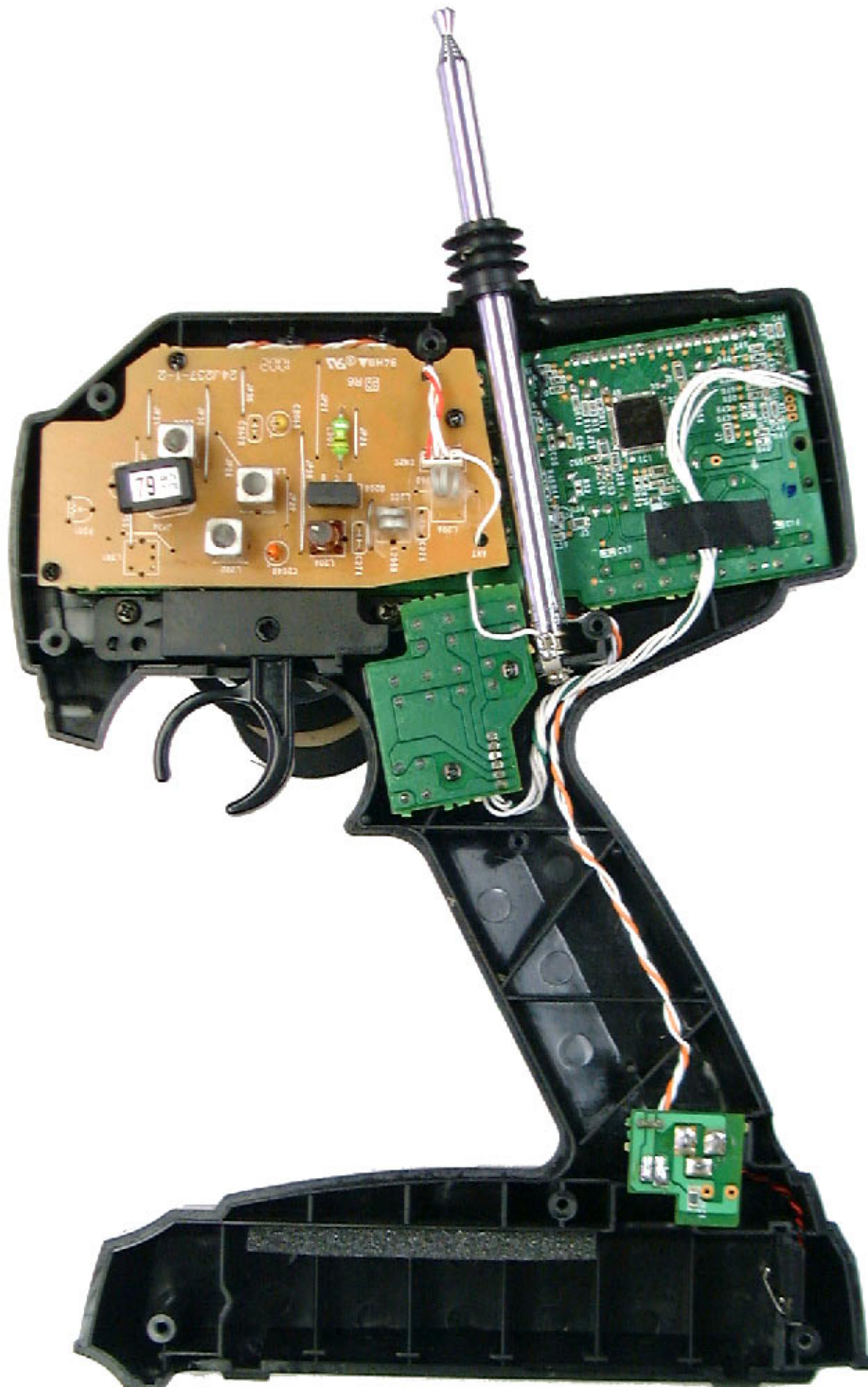



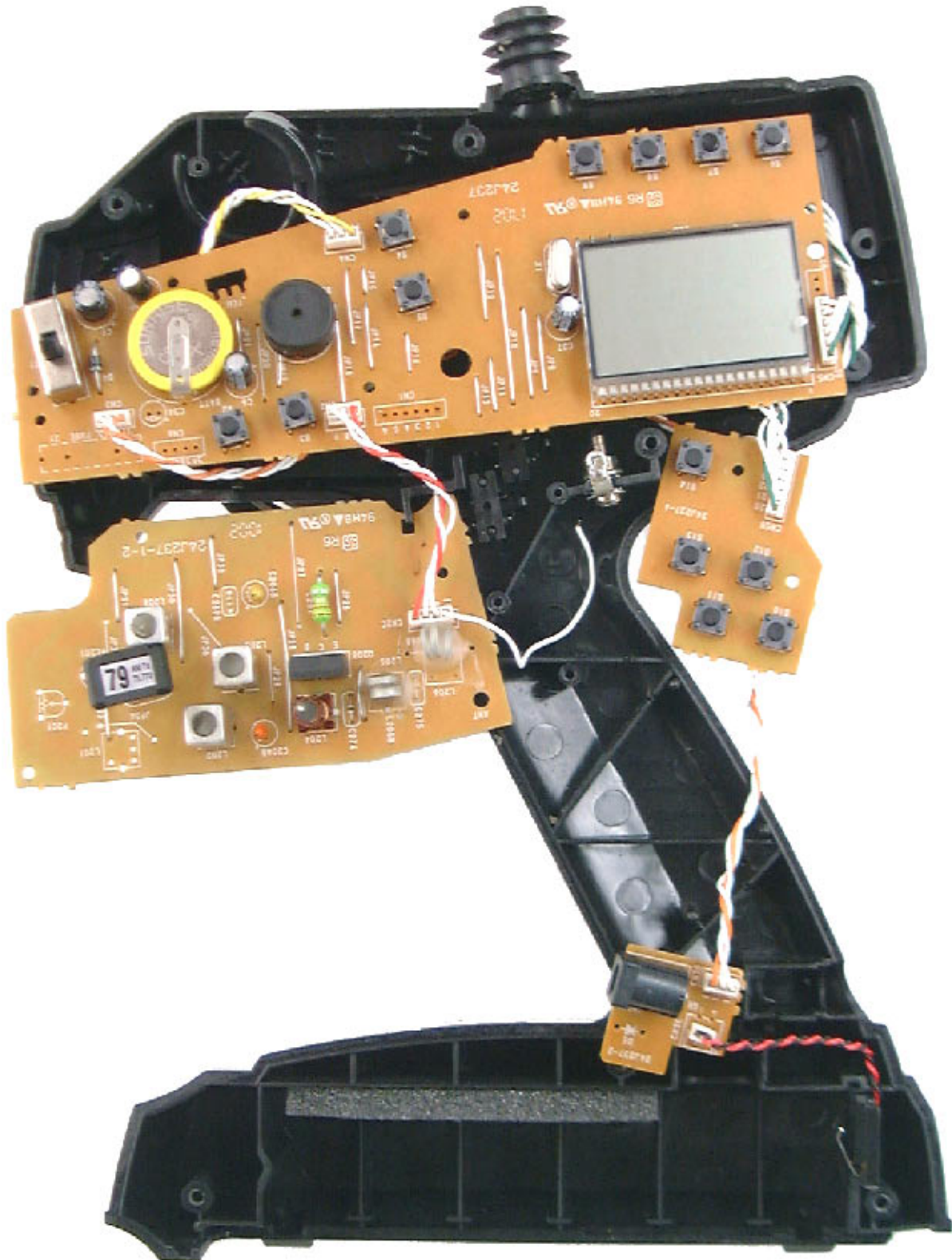







**FCC LABEL**

**FCC ID# BRWXR2I**