

MEASUREMENT REPORT

FCC PART 15.247/ IC RSS-247

FCC ID: BRWTIARLGTNG1
IC: 6157A-TIARLGTNG1
Applicant: Horizon Hobby, LLC
Application Type: Certification
Product: Receiver
Model No.: AR637T
Brand Name: Spektrum
FCC Classification: Digital Transmission System (DTS)
FCC Rule Part(s): Part 15 Subpart C (Section 15.247)
IC Rule(s): RSS-247 Issue 2, RSS-GEN Issue 5
Test Procedure(s): ANSI C63.10-2013, KDB 558074 D01v05r02
Test Date: April 11 ~ 26, 2019

Reviewed By:



(Sunny Sun)

Approved By:

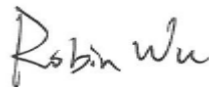

(Robin Wu)



The test results relate only to the samples tested.

This equipment has been shown to be capable of compliance with the applicable technical standards as indicated in the measurement report and was tested in accordance with the measurement procedures specified in ANSI C63.10-2013. Test results reported herein relate only to the item(s) tested.

The test report shall not be reproduced except in full without the written approval of MRT Technology (Suzhou) Co., Ltd.

Revision History

Report No.	Version	Description	Issue Date	Note
1904RSU006-U1	Rev. 01	Initial Report	05-16-2019	Valid

CONTENTS

Description	Page
1. INTRODUCTION	6
1.1. Scope.....	6
1.2. MRT Test Location.....	6
2. PRODUCT INFORMATION	7
2.1. Feature of Equipment under Test	7
2.2. Working Frequencies	7
2.3. Test Mode	7
2.4. Device Capabilities	8
2.5. Test Configuration.....	8
2.6. EMI Suppression Device(s)/Modifications.....	8
2.7. Labeling Requirements	9
3. DESCRIPTION of TEST	10
3.1. Evaluation Procedure.....	10
3.2. AC Line Conducted Emissions.....	10
3.3. Radiated Emissions	11
4. ANTENNA REQUIREMENTS	12
5. TEST EQUIPMENT CALIBRATION DATE	13
6. MEASUREMENT UNCERTAINTY	15
7. TEST RESULT	16
7.1. Summary.....	16
7.2. 6dB Bandwidth Measurement.....	17
7.2.1. Test Limit.....	17
7.2.2. Test Procedure used	17
7.2.3. Test Setting	17
7.2.4. Test Setup	17
7.2.5. Test Result	18
7.3. Output Power Measurement	19
7.3.1. Test Limit.....	19
7.3.2. Test Procedure Used.....	19
7.3.3. Test Setting	19
7.3.4. Test Setup	19
7.3.5. Test Result	20
7.4. Power Spectral Density Measurement.....	21

7.4.1.	Test Limit	21
7.4.2.	Test Procedure Used.....	21
7.4.3.	Test Setting	21
7.4.4.	Test Setup	22
7.4.5.	Test Result	23
7.5.	Conducted Band Edge and Out-of-Band Emissions	26
7.5.1.	Test Limit	26
7.5.2.	Test Procedure Used.....	26
7.5.3.	Test Setting	26
7.5.4.	Test Setup	27
7.5.5.	Test Result	28
7.6.	Radiated Spurious Emission Measurement	31
7.6.1.	Test Limit	31
7.6.2.	Test Procedure Used.....	31
7.6.3.	Test Setting	31
7.6.4.	Test Setup	33
7.6.5.	Test Result	34
7.7.	Radiated Restricted Band Edge Measurement.....	42
7.7.1.	Test Limit	42
7.7.2.	Test Procedure Used.....	45
7.7.3.	Test Setting	45
7.7.4.	Test Setup	46
7.7.5.	Test Result	47
7.8.	AC Conducted Emissions Measurement	55
7.8.1.	Test Limit	55
7.8.2.	Test Setup	55
7.8.3.	Test Result	55
8.	CONCLUSION	56
	Appendix A - Test Setup Photograph.....	57
	Appendix B - EUT Photograph	58

§2.1033 General Information

Applicant:	Horizon Hobby, LLC
Applicant FCC Address:	2904 Research Rd. Champaign, IL 61822
Applicant ISED Address:	4105 Fieldstone Rd. Champaign IL 61822 United States Of America
Manufacturer:	Horizon Hobby, LLC
Manufacturer FCC Address:	2904 Research Rd. Champaign, IL 61822
Manufacturer ISED Address:	4105 Fieldstone Rd. Champaign IL 61822 United States Of America
Test Site:	MRT Technology (Suzhou) Co., Ltd
Test Site Address:	D8 Building, No.2 Tian'edang Rd., Wuzhong Economic Development Zone, Suzhou, China
Test Device Serial No.:	N/A <input type="checkbox"/> Production <input checked="" type="checkbox"/> Pre-Production <input type="checkbox"/> Engineering

Test Facility / Accreditations

Measurements were performed at MRT Laboratory located in Tian'edang Rd., Suzhou, China.

- MRT facility is a FCC registered (MRT Reg. No. 893164) test facility with the site description report on file and has met all the requirements specified in ANSI C63.4-2014.
- MRT facility is an IC registered (MRT Reg. No. 11384A-1) test laboratory with the site description on file at Industry Canada.
- MRT facility is a VCCI registered (R-20025, G-20034, C-20020, T-20020) test laboratory with the site description on file at VCCI Council.
- MRT Lab is accredited to ISO 17025 by the American Association for Laboratory Accreditation (A2LA) under the American Association for Laboratory Accreditation Program (A2LA Cert. No. 3628.01) in EMC, Telecommunications, Radio and SAR testing.



1. INTRODUCTION

1.1. Scope

Measurement and determination of electromagnetic emissions (EMC) of radio frequency devices including intentional and/or unintentional radiators for compliance with the technical rules and regulations of the Federal Communications Commission and the Industry Canada Certification and Engineering Bureau.

1.2. MRT Test Location

The map below shows the location of the MRT LABORATORY, its proximity to the Taihu Lake. These measurement tests were conducted at the MRT Technology (Suzhou) Co., Ltd. Facility located at D8 Building, No.2 Tian'edang Rd., Wuzhong Economic Development Zone, Suzhou, China. The measurement facility compliant with the test site requirements specified in ANSI C63.4-2014.



2. PRODUCT INFORMATION

2.1. Feature of Equipment under Test

Product Name:	Receiver
Model No.:	AR637T
Brand Name:	Spektrum
Frequency Range:	2402 ~ 2478 MHz
Type of Modulation:	GFSK
Channel Number:	23
Antenna Information:	2T _x & 2R _x , SISO Mode Only Dipole Antenna, 2dBi

2.2. Working Frequencies

Channel	Frequency	Channel	Frequency
01	2402 MHz	02	2405 MHz
03	2409 MHz	04	2412 MHz
05	2415 MHz	06	2418 MHz
07	2422 MHz	08	2425 MHz
09	2428 MHz	10	2431 MHz
11	2435 MHz	12	2438 MHz
13	2440 MHz	14	2444 MHz
15	2448 MHz	16	2451 MHz
17	2454 MHz	18	2457 MHz
19	2461 MHz	20	2464 MHz
21	2467 MHz	22	2471 MHz
23	2478 MHz	---	---

Note: The engineer test sample was provided by the manufacturer, it was configured into fixed frequency T_x status after power on.

2.3. Test Mode

Test Mode	Mode 1: Transmit by GFSK
-----------	--------------------------

2.4. Device Capabilities

This device contains the following capabilities:

2.4G Transmitter.

The maximum achievable duty cycles for all modes were determined based on measurements performed on a spectrum analyzer in zero-span mode with RBW = 1MHz, VBW = 3MHz, and detector = peak. The RBW and VBW were both greater than 50/T, where T is the minimum transmission duration, and the number of sweep points across T was greater than 100. The duty cycles are as follows:

Time On (ms)	One Period (ms)	Duty Cycle (%)	Duty Cycle Factor (dB)
12.60	100	12.60	-17.99

Note: Duty Cycle Factor = 20*Log (Duty Cycle)

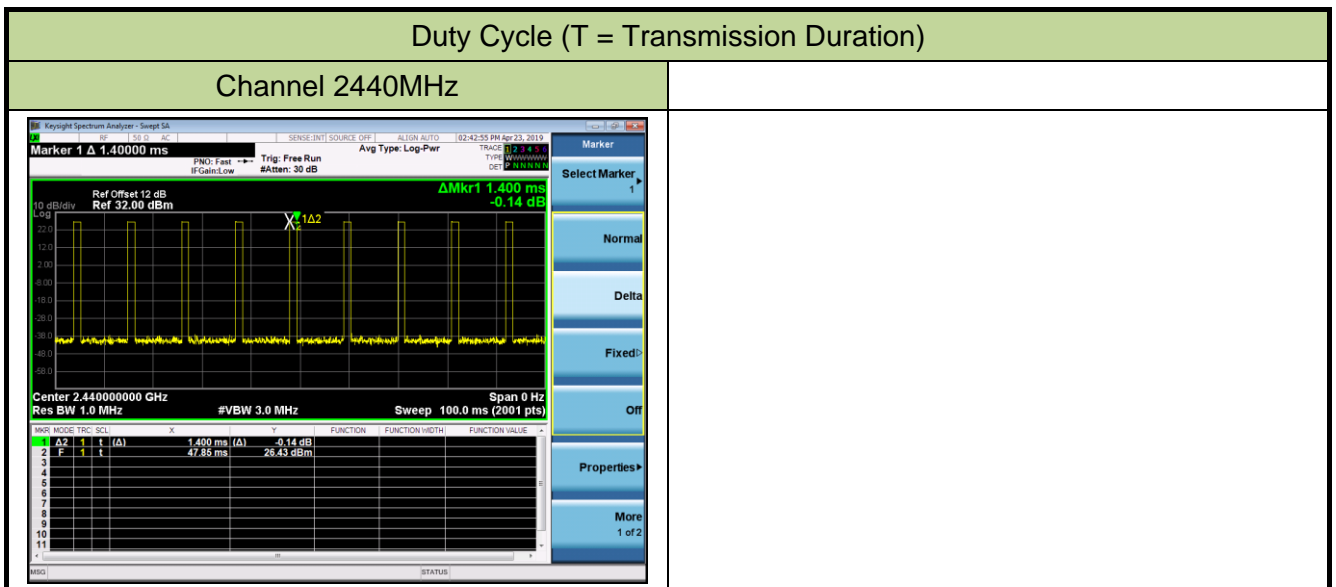

2.5. Test Configuration

The device was tested per the guidance of ANSI C63.10-2013. ANSI C63.10-2013 was used to reference the appropriate EUT setup for radiated spurious emissions testing and AC line conducted testing.

2.6. EMI Suppression Device(s)/Modifications

No EMI suppression device(s) were added and/or no modifications were made during testing.

2.7. Labeling Requirements

Per 2.1074 & 15.19; Docket 95-19

The label shall be permanently affixed at a conspicuous location on the device; instruction manual or pamphlet supplied to the user and be readily visible to the purchaser at the time of purchase.

However, when the device is so small wherein placement of the label with specified statement is not practical, only the FCC ID must be displayed on the device per Section 15.19(a)(5). Please see attachment for FCC ID label and label location.

RSP-100 Issue 11 Section 3

The manufacturer, importer or distributor shall meet the labelling requirements set out in this section for every unit:

(i) prior to marketing in Canada, for products manufactured in Canada

(ii) prior to importation into Canada, for imported products

For information regarding the e-labelling option, see Notice 2014-DRS1003. The label for the certified product represents the manufacturer's or importer's compliance with Innovation, Science and Economic Development Canada's (ISED) regulatory requirements.

Please see attachment for IC label and label location.

3. DESCRIPTION of TEST

3.1. Evaluation Procedure

The measurement procedures described in the American National Standard for Testing Unlicensed Wireless Devices (ANSI C63.10-2013), and the guidance was used in the measurement of the device.

Deviation from measurement procedure.....None

3.2. AC Line Conducted Emissions

The line-conducted facility is located inside an 8'x4'x4' shielded enclosure. A 1m x 2m wooden table 80cm high is placed 40cm away from the vertical wall and 80cm away from the sidewall of the shielded room. Two 10kHz-30MHz, 50Ω/50uH Line-Impedance Stabilization Networks (LISNs) are bonded to the shielded room floor. Power to the LISNs is filtered by external high-current high-insertion loss power line filters. These filters attenuate ambient signal noise from entering the measurement lines. These filters are also bonded to the shielded enclosure.

The EUT is powered from one LISN and the support equipment is powered from the second LISN. All interconnecting cables more than 1 meter were shortened to a 1 meter length by non-inductive bundling (serpentine fashion) and draped over the back edge of the test table. All cables were at least 40cm above the horizontal reference ground-plane. Power cables for support equipment were routed down to the second LISN while ensuring that that cables were not draped over the second LISN.

Sufficient time for the EUT, support equipment, and test equipment was allowed in order for them to warm up to their normal operating condition. The RF output of the LISN was connected to the receiver and exploratory measurements were made to determine the frequencies producing the maximum emission from the EUT. The receiver was scanned from 150kHz to 30MHz. The detector function was set to peak mode for exploratory measurements while the bandwidth of the analyzer was set to 9kHz. The EUT, support equipment, and interconnecting cables were arranged and manipulated to maximize each emission. Each emission was also maximized by varying: power lines, the mode of operation or data exchange speed, or support equipment whichever determined the worst-case emission. Once the worst case emissions have been identified, the one EUT cable configuration/arrangement and mode of operation that produced these emissions are used for final measurements on the same test site. The analyzer is set to CISPR quasi-peak and average detectors with a 9kHz resolution bandwidth for final measurements.

An extension cord was used to connect to a single LISN which powered by EUT. The extension cord was calibrated with LISN, the impedance and insertion loss are compliance with the requirements as stated in ANSI C63.10-2013.

3.3. Radiated Emissions

The radiated test facilities consisted of an indoor 3 meter semi-anechoic chamber used for final measurements and exploratory measurements, when necessary. The measurement area is contained within the semi-anechoic chamber which is shielded from any ambient interference. For measurements above 1GHz absorbers are arranged on the floor between the turn table and the antenna mast in such a way so as to maximize the reduction of reflections. For measurements below 1GHz, the absorbers are removed. A MF Model 210SS turntable is used for radiated measurement. It is a continuously rotatable, remote controlled, metallic turntable and 2 meters (6.56 ft.) in diameter. The turn table is flush with the raised floor of the chamber in order to maintain its function as a ground plane. An 80cm high PVC support structure is placed on top of the turntable.

For all measurements, the spectrum was scanned through all EUT azimuths and from 1 to 4 meter receive antenna height using a broadband antenna from 30MHz up to the upper frequency shown in 15.33(b)(1) depending on the highest frequency generated or used in the device or on which the device operates or tunes. For frequencies above 1GHz, linearly polarized double ridge horn antennas were used. For frequencies below 30MHz, a calibrated loop antenna was used. When exploratory measurements were necessary, they were performed at 1 meter test distance inside the semi-anechoic chamber using broadband antennas, broadband amplifiers, and spectrum analyzers to determine the frequencies and modes producing the maximum emissions. Sufficient time for the EUT, support equipment, and test equipment was allowed in order for them to warm up to their normal operating condition. The test set-up for frequencies below 1GHz was placed on top of the 0.8 meter high, 1 x 1.5 meter table; and test set-up for frequencies 1-40GHz was placed on top of the 1.5 meter high, 1 x 1.5 meter table. The EUT, support equipment, and interconnecting cables were arranged and manipulated to maximize each emission. Appropriate precaution was taken to ensure that all emissions from the EUT were maximized and investigated. The system configuration, clock speed, mode of operation or video resolution, if applicable, turntable azimuth, and receive antenna height was noted for each frequency found.

Final measurements were made in the semi-anechoic chamber using calibrated, linearly polarized broadband and horn antennas. The test setup was configured to the setup that produced the worst case emissions. The spectrum analyzer was set to investigate all frequencies required for testing to compare the highest radiated disturbances with respect to the specified limits. The turntable containing the EUT was rotated through 360 degrees and the height of the receive antenna was varied 1 to 4 meters and stopped at the azimuth and height producing the maximum emission. Each emission was maximized by changing the orientation of the EUT through three orthogonal planes and changing the polarity of the receive antenna, whichever produced the worst-case emissions. According to 3dB Beam-Width of horn antenna, the horn antenna should be always directed to the EUT when rising height.

4. ANTENNA REQUIREMENTS

Excerpt from §15.203 of the FCC Rules/Regulations:

“An intentional radiator antenna shall be designed to ensure that no antenna other than that furnished by the responsible party can be used with the device. The use of a permanently attached antenna or of an antenna that uses a unique coupling to the intentional radiator shall be considered sufficient to comply with the provisions of this section.”

Conclusion:

The device unit complies with the requirement of §15.203.

5. TEST EQUIPMENT CALIBRATION DATE

Conducted Emissions - SR2

Instrument	Manufacturer	Type No.	Asset No.	Cali. Interval	Cali. Due Date
EMI Test Receiver	R&S	ESR3	MRTSUE06185	1 year	2020/04/15
Two-Line V-Network	R&S	ENV 216	MRTSUE06002	1 year	2019/06/14
Two-Line V-Network	R&S	ENV 216	MRTSUE06003	1 year	2019/06/14
Thermohygrometer	Testo	608-H1	MRTSUE06404	1 year	2019/08/14
Shielding Anechoic Chamber	MIX-BEP	Chamber-SR2	MRTSUE06214	N/A	N/A

Radiated Emissions - AC1

Instrument	Manufacturer	Type No.	Asset No.	Cali. Interval	Cali. Due Date
EMI Test Receiver	R&S	ESR7	MRTSUE06001	1 year	2019/08/13
PXA Signal Analyzer	Keysight	9030B	MRTSUE06395	1 year	2019/09/25
Loop Antenna	Schwarzbeck	FMZB 1519	MRTSUE06025	1 year	2019/11/09
Bilog Period Antenna	Schwarzbeck	VULB 9168	MRTSUE06172	1 year	2020/03/31
Broad Band Horn Antenna	Schwarzbeck	BBHA 9120D	MRTSUE06023	1 year	2019/10/19
Broad Band Horn Antenna	Schwarzbeck	BBHA 9170	MRTSUE06024	1 year	2019/12/17
Microwave System Amplifier	Agilent	83017A	MRTSUE06076	1 year	2019/11/16
Preamplifier	Schwarzbeck	BBV 9721	MRTSUE06121	1 year	2019/06/12
Thermohygrometer	Testo	608-H1	MRTSUE06403	1 year	2019/08/14
Anechoic Chamber	TDK	Chamber-AC1	MRTSUE06213	1 year	2019/05/01

Radiated Emission - AC2

Instrument	Manufacturer	Type No.	Asset No.	Cali. Interval	Cali. Due Date
Spectrum Analyzer	Keysight	N9038A	MRTSUE06125	1 year	2019/08/13
Loop Antenna	Schwarzbeck	FMZB 1519	MRTSUE06025	1 year	2019/11/09
Bilog Period Antenna	Schwarzbeck	VULB 9162	MRTSUE06022	1 year	2019/10/19
Horn Antenna	Schwarzbeck	BBHA9120D	MRTSUE06171	1 year	2019/11/09
Broad Band Horn Antenna	Schwarzbeck	BBHA 9170	MRTSUE06024	1 year	2019/12/17
Broadband Coaxial Preamplifier	Schwarzbeck	BBV 9718	MRTSUE06176	1 year	2019/11/16
Preamplifier	Schwarzbeck	BBV 9721	MRTSUE06121	1 year	2019/06/12
Temperature/Humidity Meter	Minggao	ETH529	MRTSUE06170	1 year	2019/12/13
Anechoic Chamber	RIKEN	Chamber-AC2	MRTSUE06213	1 year	2019/05/01

Conducted Test Equipment - TR3

Instrument	Manufacturer	Type No.	Asset No.	Cali. Interval	Cali. Due Date
EXA Signal Analyzer	Agilent	N9020A	MRTSUE06106	1 year	2020/04/15
EXA Signal Analyzer	Keysight	N9010B	MRTSUE06452	1 year	2019/07/19
Signal Analyzer	R&S	FSV40	MRTSUE06218	1 year	2020/04/15
Power Meter	Agilent	U2021XA	MRTSUE06030	1 year	2019/11/16
USB wideband power sensor	Keysight	U2021XA	MRTSUE06446	1 year	2019/07/19
USB wideband power sensor	Keysight	U2021XA	MRTSUE06447	1 year	2019/07/05
Bluetooth Test Set	Anritsu	MT8852B-042	MRTSUE06389	1 year	2019/06/14
Audio Analyzer	Agilent	U8903B	MRTSUE06143	1 year	2019/08/14
Modulation Analyzer	HP	8901A	MRTSUE06098	1 year	2019/10/18
Wideband Radio Communication Tester	R&S	CMW 500	MRTSUE06243	1 year	2019/11/16
DC Power Supply	GWINSTEK	DPS-3303C	MRTSUE06064	N/A	N/A
Temperature & Humidity Chamber	BAOYT	BYH-150CL	MRTSUE06051	1 year	2019/11/16
Thermohygrometer	testo	608-H1	MRTSUE06401	1 year	2019/08/14

Software	Version	Function
EMI Software	V3	EMI Test Software

6. MEASUREMENT UNCERTAINTY

Where relevant, the following test uncertainty levels have been estimated for tests performed on the EUT as specified in CISPR 16-4-2. This uncertainty represents an expanded uncertainty expressed at approximately the 95% confidence level using a coverage factor of $k = 2$.

AC Conducted Emission Measurement - SR2
Measuring Uncertainty for a Level of Confidence of 95% ($U=2Uc(y)$): 150kHz~30MHz: 3.46dB
Radiated Emission Measurement - AC1
Measuring Uncertainty for a Level of Confidence of 95% ($U=2Uc(y)$): 9kHz ~ 1GHz: 4.18dB 1GHz ~ 25GHz: 4.76dB
Radiated Emission Measurement - AC2
Measuring Uncertainty for a Level of Confidence of 95% ($U=2Uc(y)$): 9kHz ~ 1GHz: 3.86dB 1GHz ~ 25GHz: 4.33dB

7. TEST RESULT

7.1. Summary

FCC Section(s)	IC Section(s)	Test Description	Test Limit	Test Condition	Test Result	Reference
15.247(a)(2)	RSS-247 [5.2]	6dB Bandwidth	$\geq 500\text{kHz}$	Conducted	Pass	Section 7.2
15.247(b)(3)	RSS-247 [5.4(4)]	Output Power	$\leq 30\text{dBm}$		Pass	Section 7.3
15.247(e)	RSS-247 [5.2]	Power Spectral Density	$\leq 8\text{dBm}/3\text{kHz}$		Pass	Section 7.4
15.247(d)	RSS-247 [5.5]	Band Edge / Out-of-Band Emissions	$\leq 30\text{dBc(Peak)}$		Pass	Section 7.5
15.205 15.209	RSS-247 [5.5]	General Field Strength Limits (Restricted Bands and Radiated Emission Limits)	Emissions in restricted bands must meet the radiated limits detailed in 15.209	Radiated	Pass	Section 7.6 & 7.7
15.207	RSS-Gen [8.8]	AC Conducted Emissions 150kHz - 30MHz	$< \text{FCC } 15.207 \text{ limits}$	Line Conducted	N/A	Section 7.8

Notes:

- 1) All modes of operation and data rates were investigated. For radiated emission test, every axis (X, Y, Z) was also verified. The test results shown in the following sections represent the worst case emissions.
- 2) The analyzer plots shown in this section were all taken with a correction table loaded into the analyzer. The correction table was used to account for the losses of the cables and attenuators used as part of the system to connect the EUT to the analyzer at all frequencies of interest.
- 3) "N/A" means that the test item is not applicable, and the details information refer to relevant section.
- 4) Test Items "6dB Bandwidth" & "Band Edge / Out-of-Band Emissions" have been assessed each transmission, and showed the worst test data in this report.

7.2. 6dB Bandwidth Measurement

7.2.1. Test Limit

The minimum 6dB bandwidth shall be at least 500 kHz.

7.2.2. Test Procedure used

ANSI C63.10-2013 Section 11.8

7.2.3. Test Setting

1. The Spectrum's automatic bandwidth measurement capability was used to perform the 6dB bandwidth measurement. The "X" dB bandwidth parameter was set to $X = 6$. The bandwidth measurement was not influenced by any intermediate power nulls in the fundamental emission.
2. Set RBW = 100 kHz
3. VBW $\geq 3 \times$ RBW
4. Detector = Peak
5. Trace mode = max hold
6. Sweep = auto couple
7. Allow the trace was allowed to stabilize

7.2.4. Test Setup

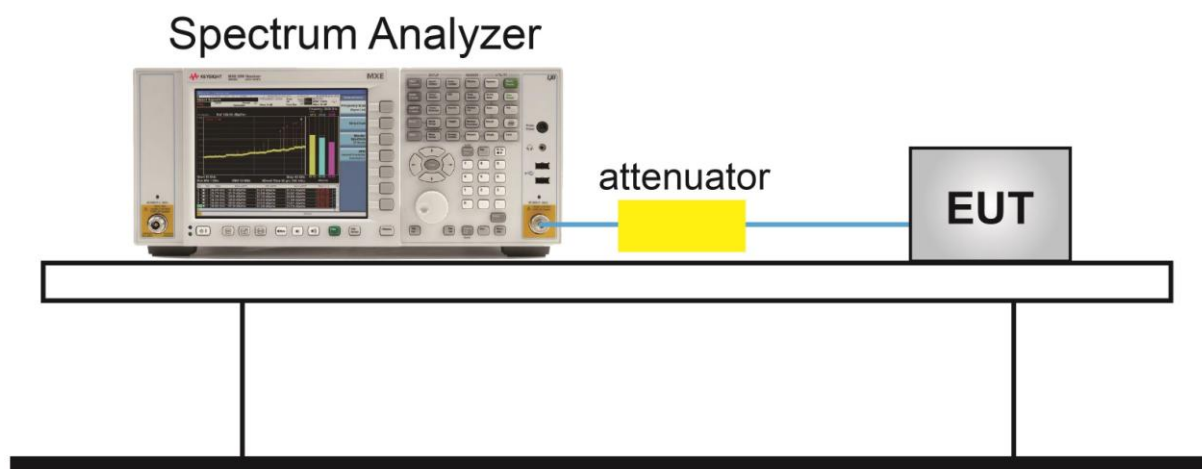

7.2.5. Test Result

Product	Receiver	Temperature	25°C
Test Engineer	Ternence Wang	Relative Humidity	52%
Test Site	TR3	Test Date	2019/04/23

Test Mode	Channel No.	Frequency (MHz)	6dB Bandwidth (MHz)	99% Bandwidth (MHz)	Limit (MHz)	Result
Ant A						
GFSK	01	2402	0.68	1.06	≥ 0.5	Pass
GFSK	13	2440	0.68	1.05	≥ 0.5	Pass
GFSK	23	2478	0.66	1.06	≥ 0.5	Pass

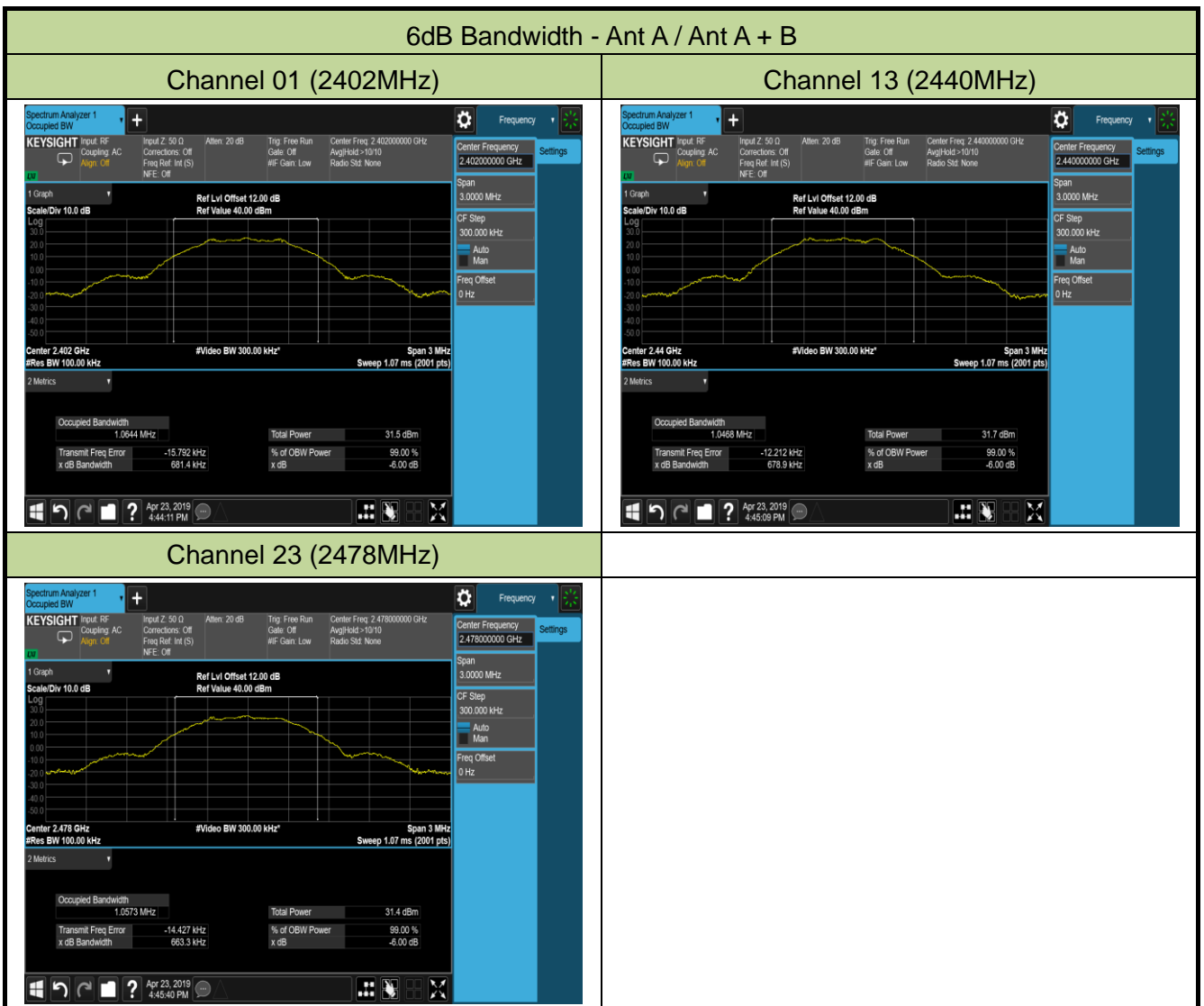

7.3. Output Power Measurement

7.3.1. Test Limit

The maximum out power shall be less 1 Watt (30dBm).

The conducted output power limit specified in paragraph FCC Part 15.247(b) of this section is based on the use of antennas with directional gains that do not exceed 6 dBi. If transmitting antennas of directional gain greater than 6 dBi are used, the conducted output power from the intentional radiator shall be reduced below the stated values in paragraphs FCC Part 15.247(b)(3) of this section, as appropriate, by the amount in dB that the directional gain of the antenna exceeds 6 dBi.

7.3.2. Test Procedure Used

ANSI C63.10 Section 11.9.2.3.2

7.3.3. Test Setting

Average Power Measurement

Average power measurements were perform only when the EUT was transmitting at its maximum power control level using a broadband power meter with a pulse sensor. The power meter implemented triggering and gating capabilities which were set up such that power measurements were recorded only during the ON time of the transmitter.

7.3.4. Test Setup

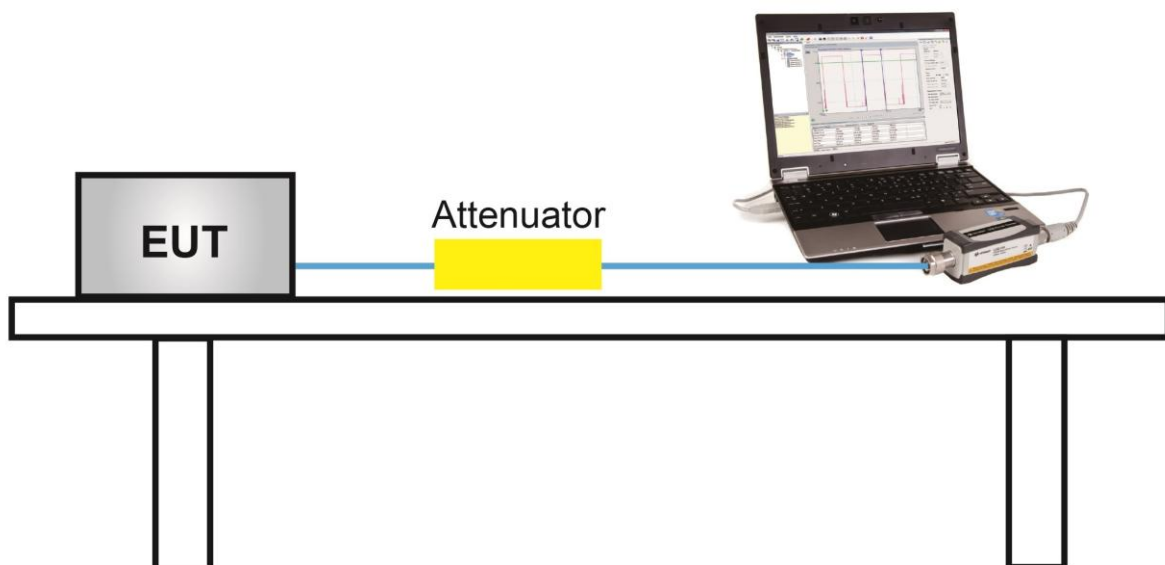

7.3.5. Test Result

Product	Receiver	Temperature	23°C
Test Engineer	Ternence Wang	Relative Humidity	51%
Test Site	TR3	Test Date	2019/04/23

Test Mode	Channel No.	Freq. (MHz)	Average Power (dBm)		Limit (dBm)	Result
			Ant A	Ant B		
GFSK	01	2402	25.49	25.25	≤ 30.00	Pass
GFSK	13	2440	25.71	25.45	≤ 30.00	Pass
GFSK	23	2478	25.73	25.38	≤ 30.00	Pass

Note: The max EIRP = 25.73dBm + 2dBi = 27.73dBm.

7.4. Power Spectral Density Measurement

7.4.1. Test Limit

The maximum permissible power spectral density is 8dBm in any 3 kHz band.

The same method of determining the conducted output power shall be used to determine the power spectral density.

7.4.2. Test Procedure Used

ANSI C63.10 Section 11.10.5

7.4.3. Test Setting

1. Measure the duty cycle (x) of the transmitter output signal.
2. Set instrument center frequency to DTS channel center frequency.
3. Set span to at least 1.5 times the OBW.
4. RBW = 10 kHz.
5. VBW = 30 kHz.
6. Detector = RMS.
7. Ensure that the number of measurement points in the sweep $\geq 2 \times \text{span}/\text{RBW}$.
8. Sweep time = auto couple.
9. Don't use sweep triggering. Allow sweep to "free run".
10. Employ trace averaging (RMS) mode over a minimum of 100 traces.
11. Use the peak marker function to determine the maximum amplitude level.
12. Add $10 \log (1/x)$, where x is the duty cycle measured in step (a), to the measured PSD to compute the average PSD during the actual transmission time.

7.4.4. Test Setup

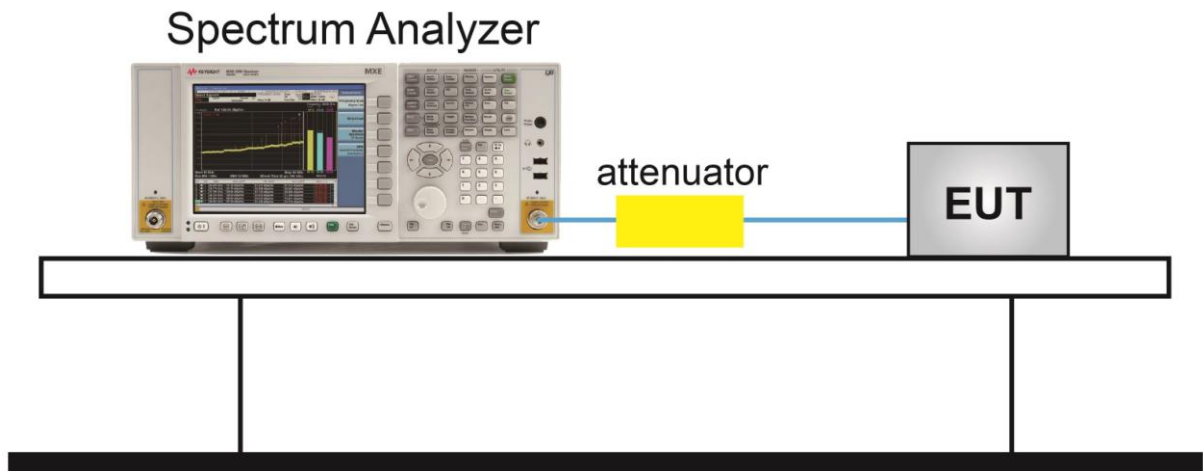

7.4.5. Test Result

Product	Receiver	Temperature	23°C
Test Engineer	Ternence Wang	Relative Humidity	52%
Test Site	TR3	Test Date	2019/04/24

Test Mode	Channel No.	Freq. (MHz)	AVGPSD (dBm / 10kHz)	Duty Cycle (%)	Final AVGPSD (dBm / 3kHz)	Limit (dBm / 3kHz)	Result
Ant A							
GFSK	01	2402	3.50	12.60	7.27	≤ 8.00	Pass
GFSK	13	2440	3.25	12.60	7.02	≤ 8.00	Pass
GFSK	23	2478	3.57	12.60	7.34	≤ 8.00	Pass
Ant B							
GFSK	01	2402	3.59	12.60	7.36	≤ 8.00	Pass
GFSK	13	2440	3.75	12.60	7.52	≤ 8.00	Pass
GFSK	23	2478	3.70	12.60	7.47	≤ 8.00	Pass

Note: Final AVGPSD (dBm / 3kHz) = AVGPSD (dBm / 10kHz) + 10*Log(3/10)+ 10*log (1/Duty Cycle).

Power Spectral Density - Ant A

Channel 01 (2402MHz)



Channel 13 (2440MHz)



Channel 23 (2478MHz)



Power Spectral Density - Ant B

Channel 01 (2402MHz)

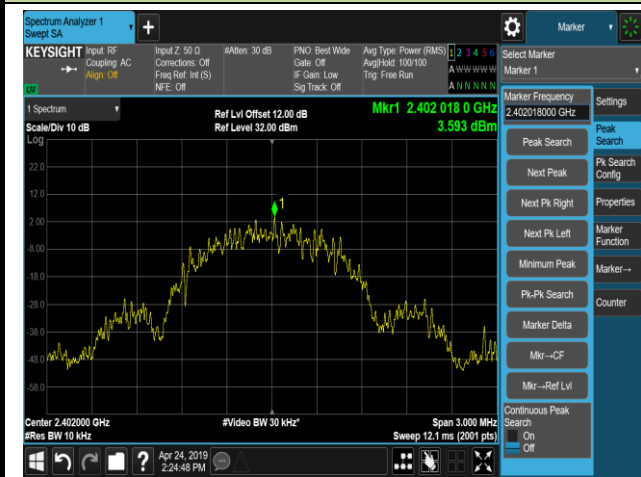

Channel 13 (2440MHz)



Channel 23 (2478MHz)

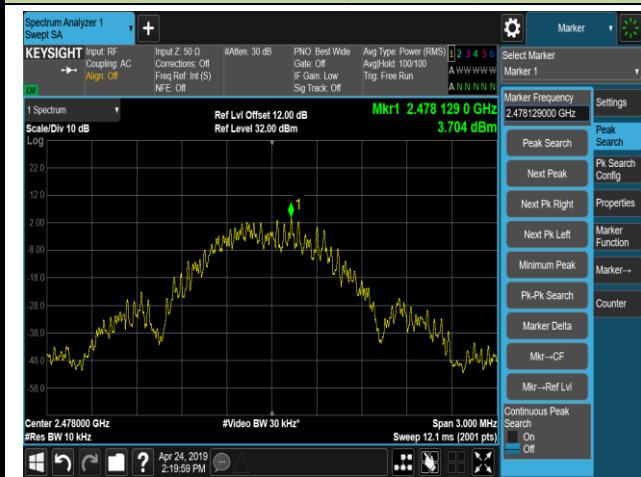

7.5. Conducted Band Edge and Out-of-Band Emissions

7.5.1. Test Limit

The limit for out-of-band spurious emissions at the band edge is 30dB below the fundamental emission level, as determined from the in-band power measurement of the DTS channel performed in a 100 kHz bandwidth per the PSD procedure.

7.5.2. Test Procedure Used

ANSI C63.10 Section 11.11

7.5.3. Test Setting

Reference level measurement

1. Set instrument center frequency to DTS channel center frequency
2. Set the span to ≥ 1.5 times the DTS bandwidth
3. Set the RBW = 100 kHz
4. Set the VBW $\geq 3 \times$ RBW
5. Detector = peak
6. Sweep time = auto couple
7. Trace mode = max hold
8. Allow trace to fully stabilize

Emission level measurement

1. Set the center frequency and span to encompass frequency range to be measured
2. RBW = 100kHz
3. VBW = 300kHz
4. Detector = Peak
5. Trace mode = max hold
6. Sweep time = auto couple
7. The trace was allowed to stabilize

Test Notes

1. RBW was set to 1.3MHz rather than 100 kHz in order to increase the measurement speed.
2. The display line shown in the following plots denotes the limit at 30Db below the fundamental emission level measured in a 100 kHz bandwidth. However, since the traces in the following plots are measured with a 1.3MHz RBW, the display line may not necessarily appear to be 30Db below the level of the fundamental in a 1.3MHz bandwidth.
3. For plots showing conducted spurious emissions near the limit, the frequencies were investigated with a reduced RBW to ensure that no emissions were present

7.5.4. Test Setup

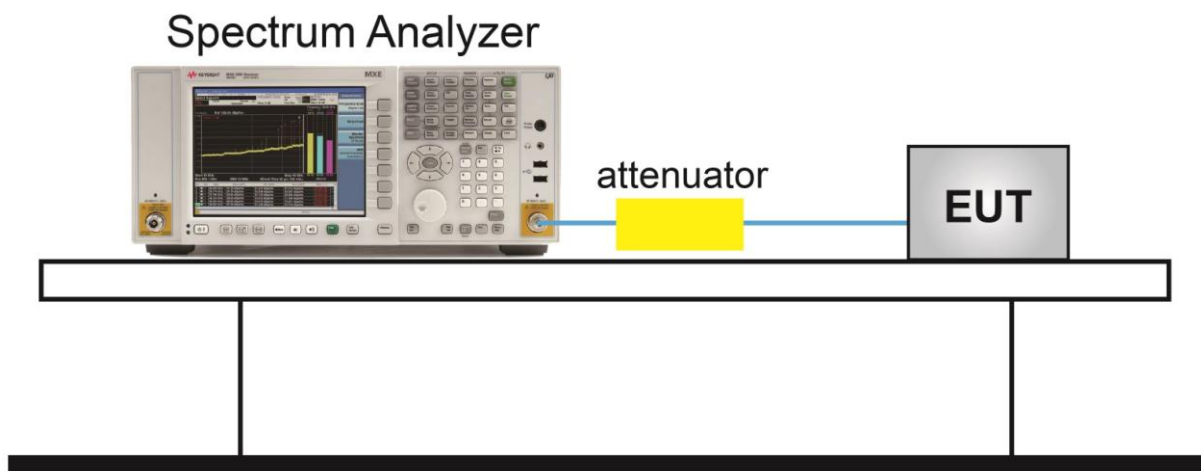

7.5.5. Test Result

Product	Receiver	Temperature	23°C
Test Engineer	Ternence Wang	Relative Humidity	52%
Test Site	TR3	Test Date	2019/04/24

Test Mode	Channel No.	Frequency (MHz)	Limit	Result
Ant A				
GFSK	01	2402	30dBc	Pass
GFSK	13	2440	30dBc	Pass
GFSK	23	2478	30dBc	Pass

Out-of-Band Emissions

Channel 01 (2402MHz) - Ant A

100kHz PSD reference Level



Low Band Edge

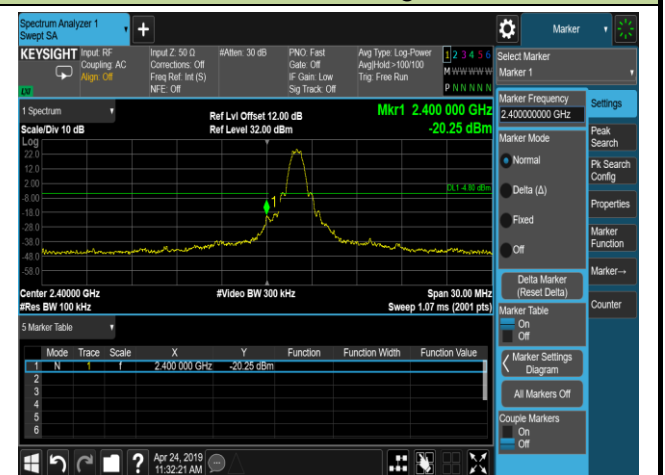

Spurious Emission



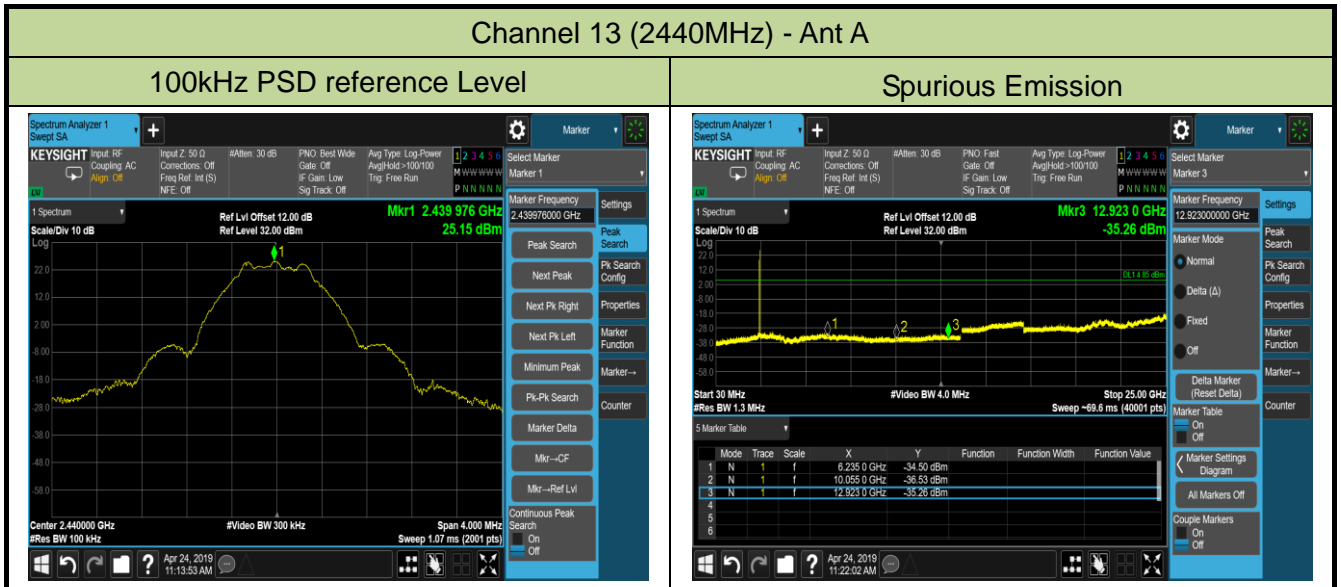

Channel 23 (2478MHz) - Ant A

100kHz PSD reference Level



High Band Edge



Spurious Emission



7.6. Radiated Spurious Emission Measurement

7.6.1. Test Limit

All out of band emissions appearing in a restricted band as specified in Section 15.205 of the Title 47 CFR must not exceed the limits shown in Table per Section 15.209.

FCC Part 15 Subpart C Paragraph 15.209		
Frequency [MHz]	Field Strength [V/m]	Measured Distance [Meters]
0.009 - 0.490	2400/F (kHz)	300
0.490 - 1.705	24000/F (kHz)	30
1.705 - 30	30	30
30 - 88	100	3
88 - 216	150	3
216 - 960	200	3
Above 960	500	3

7.6.2. Test Procedure Used

ANSI C63.10 Section 6.3 (General Requirements)

ANSI C63.10 Section 6.4 (Standard test method below 30MHz)

ANSI C63.10 Section 6.5 (Standard test method above 30MHz to 1GHz)

ANSI C63.10 Section 6.6 (Standard test method above 1GHz)

7.6.3. Test Setting

Quasi-Peak Measurements below 1GHz

1. Analyzer center frequency was set to the frequency of the radiated spurious emission of interest
2. Span was set greater than 1MHz
3. RBW = as specified in Table 1
4. Detector = CISPR quasi-peak or average
5. Sweep time = auto couple
6. Trace was allowed to stabilize

Table 1 - RBW as a function of frequency

Frequency	RBW
9 ~ 150 kHz	200 ~ 300 Hz
0.15 ~ 30 MHz	9 ~ 10 kHz
30 ~ 1000 MHz	100 ~ 120 kHz

Peak Measurements above 1GHz

1. Analyzer center frequency was set to the frequency of the radiated spurious emission of interest
2. RBW = 1MHz
3. VBW = 3MHz
4. Detector = peak
5. Sweep time = auto couple
6. Trace mode = max hold
7. Trace was allowed to stabilize

7.6.4. Test Setup

Below 1GHz Test Setup:

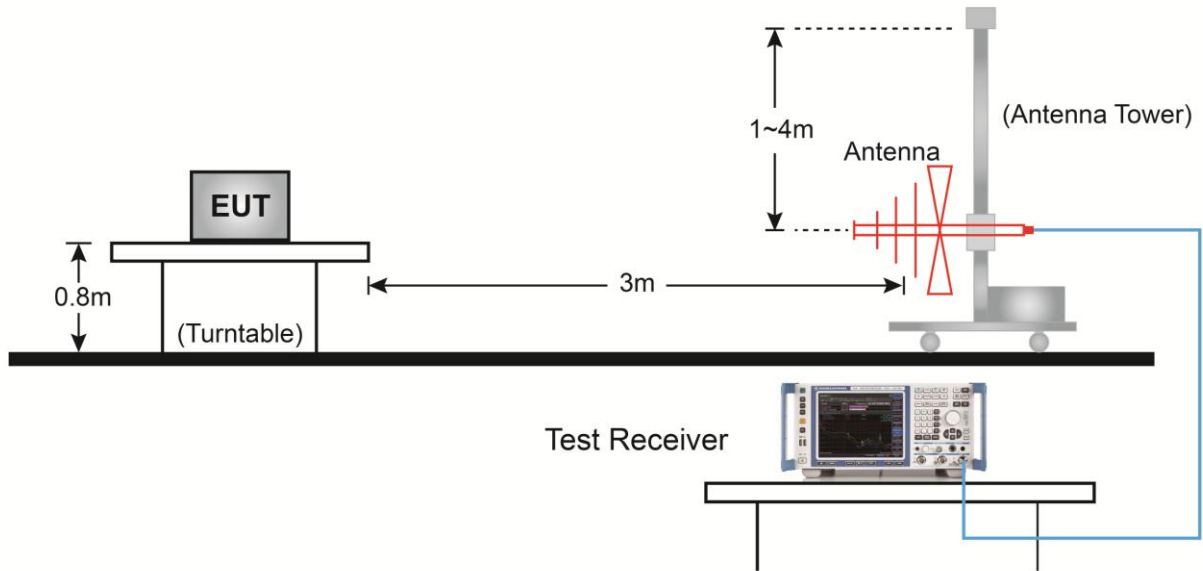

Above 1GHz Test Setup:

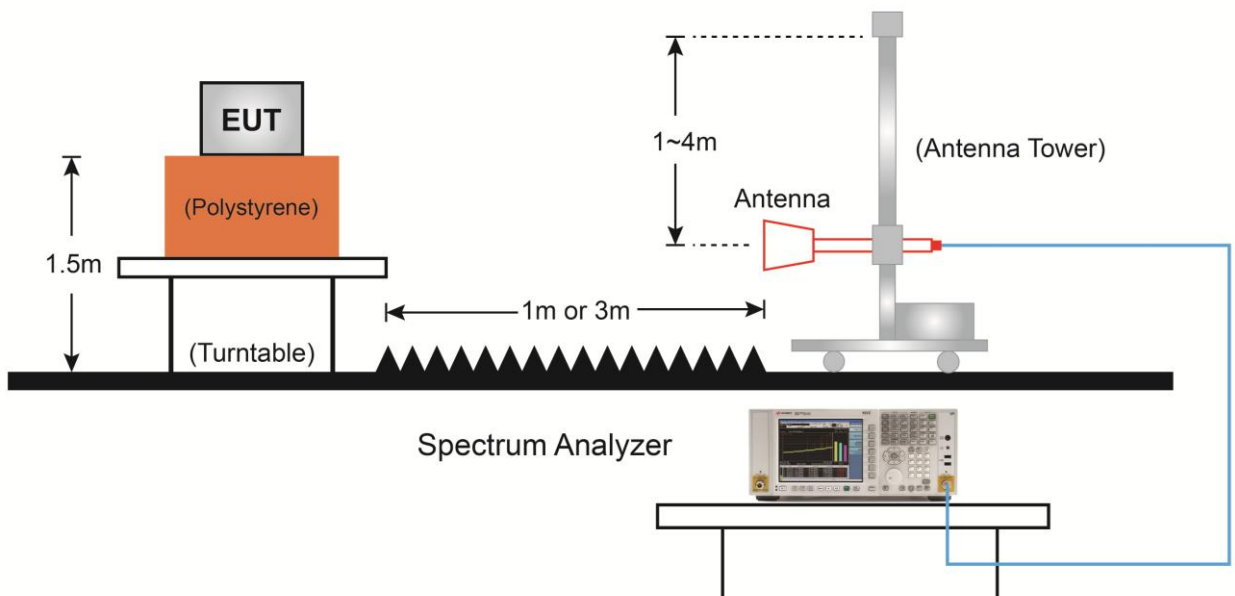

7.6.5. Test Result

Product	Receiver	Temperature	26°C
Test Engineer	Ternence Wang	Relative Humidity	56%
Test Site	AC1	Test Date	2019/04/24
Test Mode:	Ant A	Test Channel:	01
Remark:	1. Average measurement was not performed if peak level lower than average limit (54dBμV/m). 2. Other frequency was 20dB below limit line within 1-18GHz, there is not show in the report.		

Mark	Frequency (MHz)	Reading Level (dBμV)	Factor (dB)	Duty Cycle Factor (dB)	Measure Level (dBμV/m)	Limit (dBμV/m)	Margin (dB)	Detector	Polarization
	4799.5	54.7	4.6	N/A	59.3	74.0	-14.7	Peak	Horizontal
	4799.5	54.7	4.6	-18.0	41.3	54.0	-12.7	Average	Horizontal
*	7205.0	53.2	10.5	N/A	63.7	90.2	-26.5	Peak	Horizontal
*	9610.5	52.4	14.0	N/A	66.4	90.2	-23.8	Peak	Horizontal
	12007.5	39.0	15.3	N/A	54.3	74.0	-19.7	Peak	Horizontal
	12007.5	39.0	15.3	-18.0	36.3	54.0	-17.7	Average	Horizontal
	4799.5	55.2	4.6	N/A	59.8	74.0	-14.2	Peak	Vertical
	4799.5	55.2	4.6	-18.0	41.8	54.0	-12.2	Average	Vertical
*	7205.0	56.6	10.5	N/A	67.1	90.2	-23.1	Peak	Vertical
*	9610.5	55.5	14.0	N/A	69.5	90.2	-20.7	Peak	Vertical
	12007.5	42.5	15.3	N/A	57.8	74.0	-16.2	Peak	Vertical
	12007.5	42.5	15.3	-18.0	39.8	54.0	-14.2	Average	Vertical

Note 1: "*" is not in restricted band, its limit is 30dBc of the fundamental emission level (120.2dBμV/m) or 15.209 which is higher.

Note 2: Peak Measure Level (dBμV/m) = Reading Level (dBμV) + Factor (dB)

Average Measure Level = Peak Measure Level + Duty Cycle Factor

Factor (dB) = Cable Loss (dB) + Antenna Factor (dB/m) - Pre Amplifier Gain (dB)

Note 3: Average measurement was not performed when the peak level lower than average limit.

Product	Receiver	Temperature	26°C
Test Engineer	Ternence Wang	Relative Humidity	56%
Test Site	AC1	Test Date	2019/04/24
Test Mode:	Ant A	Test Channel:	13
Remark:	1. Average measurement was not performed if peak level lower than average limit (54dBμV/m). 2. Other frequency was 20dB below limit line within 1-18GHz, there is not show in the report.		

Mark	Frequency (MHz)	Reading Level (dBμV)	Factor (dB)	Duty Cycle Factor (dB)	Measure Level (dBμV/m)	Limit (dBμV/m)	Margin (dB)	Detector	Polarization
	4876.0	57.5	4.8	N/A	62.3	74.0	-11.7	Peak	Horizontal
	4876.0	57.5	4.8	-18.0	44.3	54.0	-9.7	Average	Horizontal
	7315.5	54.7	10.5	N/A	65.2	74.0	-8.8	Peak	Horizontal
	7315.5	54.7	10.5	-18.0	47.2	54.0	-6.8	Average	Horizontal
*	8939.0	35.9	12.0	N/A	47.9	92.4	-44.5	Peak	Horizontal
*	9755.0	49.3	14.5	N/A	63.8	92.4	-28.6	Peak	Horizontal
	4876.0	59.2	4.8	N/A	64.0	74.0	-10.0	Peak	Vertical
	4876.0	59.2	4.8	-18.0	46.0	54.0	-8.0	Average	Vertical
	7315.5	55.5	10.5	N/A	66.0	74.0	-8.0	Peak	Vertical
	7315.5	55.5	10.5	-18.0	48.0	54.0	-6.0	Average	Vertical
*	9763.5	51.9	14.5	N/A	66.4	92.4	-26.0	Peak	Vertical
*	14336.5	37.9	19.6	N/A	57.5	92.4	-34.9	Peak	Vertical

Note 1: "*" is not in restricted band, its limit is 30dBc of the fundamental emission level (122.4dBμV/m) or 15.209 which is higher.

Note 2: Peak Measure Level (dBμV/m) = Reading Level (dBμV) + Factor (dB)

Average Measure Level = Peak Measure Level + Duty Cycle Factor

Factor (dB) = Cable Loss (dB) + Antenna Factor (dB/m) - Pre Amplifier Gain (dB)

Note 3: Average measurement was not performed when the peak level lower than average limit.

Product	Receiver	Temperature	26°C
Test Engineer	Ternence Wang	Relative Humidity	56%
Test Site	AC1	Test Date	2019/04/24
Test Mode:	Ant A	Test Channel:	23
Remark:	1. Average measurement was not performed if peak level lower than average limit (54dB μ V/m). 2. Other frequency was 20dB below limit line within 1-18GHz, there is not show in the report.		

Mark	Frequency (MHz)	Reading Level (dB μ V)	Factor (dB)	Duty Cycle Factor (dB)	Measure Level (dB μ V/m)	Limit (dB μ V/m)	Margin (dB)	Detector	Polarization
	4952.5	60.7	4.9	N/A	65.6	74.0	-8.4	Peak	Horizontal
	4952.5	60.7	4.9	-18.0	47.6	54.0	-6.4	Average	Horizontal
	7434.5	53.7	10.7	N/A	64.4	74.0	-9.6	Peak	Horizontal
	7434.5	53.7	10.7	-18.0	46.4	54.0	-7.6	Average	Horizontal
*	9916.5	45.7	14.6	N/A	60.3	91.2	-30.9	Peak	Horizontal
*	14872.0	38.0	19.1	N/A	57.1	91.2	-34.1	Peak	Horizontal
	4952.5	59.5	4.9	N/A	64.4	74.0	-9.6	Peak	Vertical
	4952.5	59.5	4.9	-18.0	46.4	54.0	-7.6	Average	Vertical
	7434.5	57.7	10.7	N/A	68.4	74.0	-5.6	Peak	Vertical
	7434.5	57.7	10.7	-18.0	50.4	54.0	-3.6	Average	Vertical
*	9908.0	47.0	14.7	N/A	61.7	91.2	-29.5	Peak	Vertical
*	14872.0	38.2	19.1	N/A	57.3	91.2	-33.9	Peak	Vertical

Note 1: "*" is not in restricted band, its limit is 30dBc of the fundamental emission level (121.2dB μ V/m) or 15.209 which is higher.

Note 2: Peak Measure Level (dB μ V/m) = Reading Level (dB μ V) + Factor (dB)

Average Measure Level = Peak Measure Level + Duty Cycle Factor

Factor (dB) = Cable Loss (dB) + Antenna Factor (dB/m) - Pre Amplifier Gain (dB)

Note 3: Average measurement was not performed when the peak level lower than average limit.

Product	Receiver	Temperature	26°C
Test Engineer	Ternence Wang	Relative Humidity	56%
Test Site	AC1	Test Date	2019/04/24
Test Mode:	Ant B	Test Channel:	01
Remark:	1. Average measurement was not performed if peak level lower than average limit (54dBμV/m). 2. Other frequency was 20dB below limit line within 1-18GHz, there is not show in the report.		

Mark	Frequency (MHz)	Reading Level (dBμV)	Factor (dB)	Duty Cycle Factor (dB)	Measure Level (dBμV/m)	Limit (dBμV/m)	Margin (dB)	Detector	Polarization
	4808.0	62.9	4.7	N/A	67.6	74.0	-6.4	Peak	Horizontal
	4808.0	62.9	4.7	-18.0	49.6	54.0	-4.4	Average	Horizontal
*	7205.0	46.5	10.5	N/A	57.0	88.9	-31.9	Peak	Horizontal
*	9610.5	42.4	14.0	N/A	56.4	88.9	-32.5	Peak	Horizontal
	11030.0	35.6	16.3	N/A	51.9	74.0	-22.1	Peak	Horizontal
	4799.5	63.9	4.6	N/A	68.5	74.0	-5.5	Peak	Vertical
	4799.5	63.9	4.6	-18.0	50.5	54.0	-3.5	Average	Vertical
*	7205.0	46.3	10.5	N/A	56.8	88.9	-32.1	Peak	Vertical
*	9610.5	45.1	14.0	N/A	59.1	88.9	-29.8	Peak	Vertical
	12007.5	36.4	15.3	N/A	51.7	74.0	-22.3	Peak	Vertical

Note 1: "*" is not in restricted band, its limit is 30dBc of the fundamental emission level (118.9dBμV/m) or 15.209 which is higher.

Note 2: Peak Measure Level (dBμV/m) = Reading Level (dBμV) + Factor (dB)

Average Measure Level = Peak Measure Level + Duty Cycle Factor

Factor (dB) = Cable Loss (dB) + Antenna Factor (dB/m) - Pre Amplifier Gain (dB)

Note 3: Average measurement was not performed when the peak level lower than average limit.

Product	Receiver	Temperature	26°C
Test Engineer	Ternence Wang	Relative Humidity	56%
Test Site	AC1	Test Date	2019/04/24
Test Mode:	Ant B	Test Channel:	13
Remark:	1. Average measurement was not performed if peak level lower than average limit (54dBμV/m). 2. Other frequency was 20dB below limit line within 1-18GHz, there is not show in the report.		

Mark	Frequency (MHz)	Reading Level (dBμV)	Factor (dB)	Duty Cycle Factor (dB)	Measure Level (dBμV/m)	Limit (dBμV/m)	Margin (dB)	Detector	Polarization
	4876.0	61.6	4.8	N/A	66.4	74.0	-7.6	Peak	Horizontal
	4876.0	61.6	4.8	-18.0	48.4	54.0	-5.6	Average	Horizontal
	7324.0	49.6	10.5	N/A	60.1	74.0	-13.9	Peak	Horizontal
	7324.0	49.6	10.5	-18.0	42.1	54.0	-11.9	Average	Horizontal
*	9763.5	45.0	14.5	N/A	59.5	90.2	-30.7	Peak	Horizontal
*	14753.0	37.5	19.4	N/A	56.9	90.2	-33.3	Peak	Horizontal
	4876.0	61.3	4.8	N/A	66.1	74.0	-7.9	Peak	Vertical
	4876.0	61.3	4.8	-18.0	48.1	54.0	-5.9	Average	Vertical
	7324.0	52.6	10.5	N/A	63.1	74.0	-10.9	Peak	Vertical
	7324.0	52.6	10.5	-18.0	45.1	54.0	-8.9	Average	Vertical
*	9763.5	46.1	14.5	N/A	60.6	90.2	-29.6	Peak	Vertical
*	14634.0	36.5	19.7	N/A	56.2	90.2	-34.0	Peak	Vertical

Note 1: "*" is not in restricted band, its limit is 30dBc of the fundamental emission level (120.2dBμV/m) or 15.209 which is higher.

Note 2: Peak Measure Level (dBμV/m) = Reading Level (dBμV) + Factor (dB)

Average Measure Level = Peak Measure Level + Duty Cycle Factor

Factor (dB) = Cable Loss (dB) + Antenna Factor (dB/m) - Pre Amplifier Gain (dB)

Note 3: Average measurement was not performed when the peak level lower than average limit.

Product	Receiver	Temperature	26°C
Test Engineer	Ternence Wang	Relative Humidity	56%
Test Site	AC1	Test Date	2019/04/24
Test Mode:	Ant B	Test Channel:	23
Remark:	1. Average measurement was not performed if peak level lower than average limit (54dBμV/m). 2. Other frequency was 20dB below limit line within 1-18GHz, there is not show in the report.		

Mark	Frequency (MHz)	Reading Level (dBμV)	Factor (dB)	Duty Cycle Factor (dB)	Measure Level (dBμV/m)	Limit (dBμV/m)	Margin (dB)	Detector	Polarization
	4952.5	61.4	4.9	N/A	66.3	74.0	-7.7	Peak	Horizontal
	4952.5	61.4	4.9	-18.0	48.3	54.0	-5.7	Average	Horizontal
	7434.5	52.2	10.7	N/A	62.9	74.0	-11.1	Peak	Horizontal
	7434.5	52.2	10.7	-18.0	44.9	54.0	-9.1	Average	Horizontal
*	9908.0	50.9	14.7	N/A	65.6	86.1	-20.5	Peak	Horizontal
*	14812.5	36.4	19.3	N/A	55.7	86.1	-30.4	Peak	Horizontal
	4952.5	59.3	4.9	N/A	64.2	74.0	-9.8	Peak	Vertical
	4952.5	59.3	4.9	-18.0	46.2	54.0	-7.8	Average	Vertical
	7434.5	55.1	10.7	N/A	65.8	74.0	-8.2	Peak	Vertical
	7434.5	55.1	10.7	-18.0	47.8	54.0	-6.2	Average	Vertical
*	9916.5	53.3	14.6	N/A	67.9	86.1	-18.2	Peak	Vertical
*	14821.0	37.9	19.3	N/A	57.2	86.1	-28.9	Peak	Vertical

Note 1: "*" is not in restricted band, its limit is 30dBc of the fundamental emission level (116.1dBμV/m) or 15.209 which is higher.

Note 2: Peak Measure Level (dBμV/m) = Reading Level (dBμV) + Factor (dB)

Average Measure Level = Peak Measure Level + Duty Cycle Factor

Factor (dB) = Cable Loss (dB) + Antenna Factor (dB/m) - Pre Amplifier Gain (dB)

Note 3: Average measurement was not performed when the peak level lower than average limit.

The worst case of Radiated Emission below 1GHz:

Site: AC1	Time: 2019/04/25 - 22:43
Limit: FCC_Part15.209_RSE(3m)	Engineer: David Lv
Probe: VULB 9168 _20-2000MHz	Polarity: Horizontal
EUT: Receiver	Power: By Battery
Test Mode: There is the worst case within frequency range 30MHz~1GHz.	

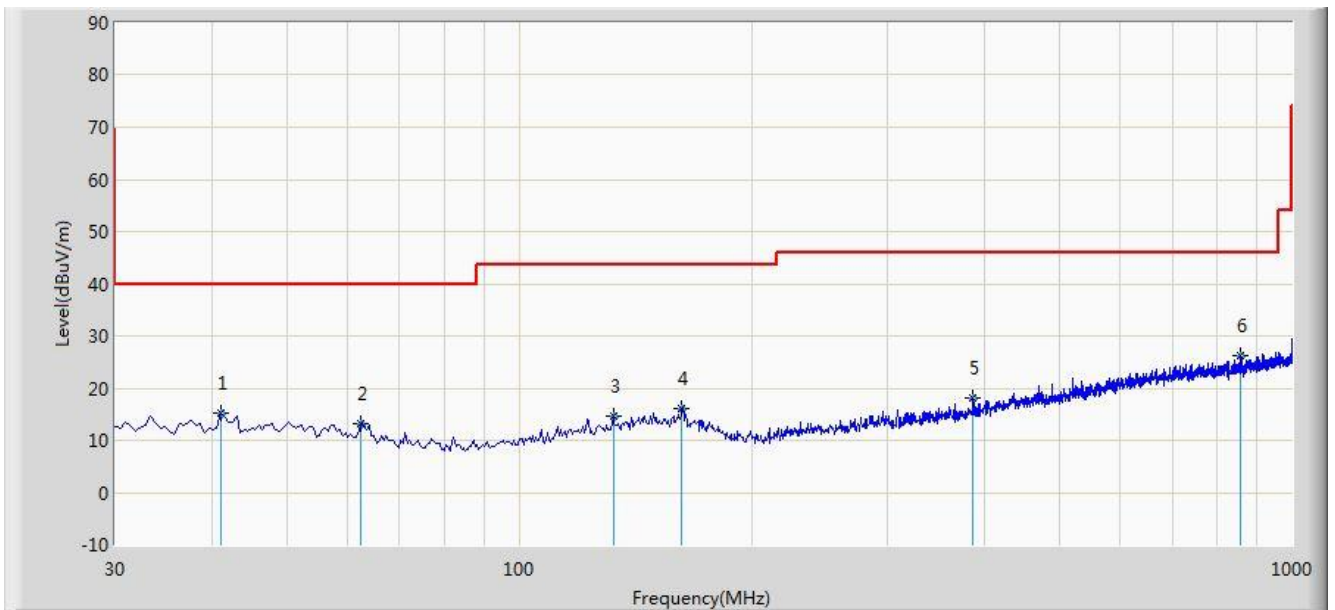

No	Flag	Mark	Frequency (MHz)	Measure Level (dBuV/m)	Reading Level (dBuV)	Margin (dB)	Limit (dBuV/m)	Factor (dB)	Type
1		*	41.155	15.196	0.595	-24.804	40.000	14.601	QP
2			62.495	13.237	0.170	-26.763	40.000	13.066	QP
3			132.335	14.550	0.431	-28.950	43.500	14.119	QP
4			162.405	16.103	0.913	-27.397	43.500	15.191	QP
5			386.475	18.131	1.660	-27.869	46.000	16.471	QP
6			856.440	26.309	2.138	-19.691	46.000	24.171	QP

Note 1: Measure Level (dB μ V/m) = Reading Level (dB μ V) + Factor (dB)

Factor (dB) = Cable Loss (dB) + Antenna Factor (dB/m)

Note 2: The test trace is same as the ambient noise and the amplitude of the emissions are attenuated more than 20dB below the permissible (the test frequency range: 9kHz ~ 30MHz, 18GHz ~ 25GHz), therefore no data appear in the report.

Site: AC1	Time: 2019/04/25 - 22:44
Limit: FCC_Part15.209_RSE(3m)	Engineer: David Lv
Probe: VULB 9168 _20-2000MHz	Polarity: Vertical
EUT: Receiver	Power: By Battery
Test Mode: There is the worst case within frequency range 30MHz~1GHz.	

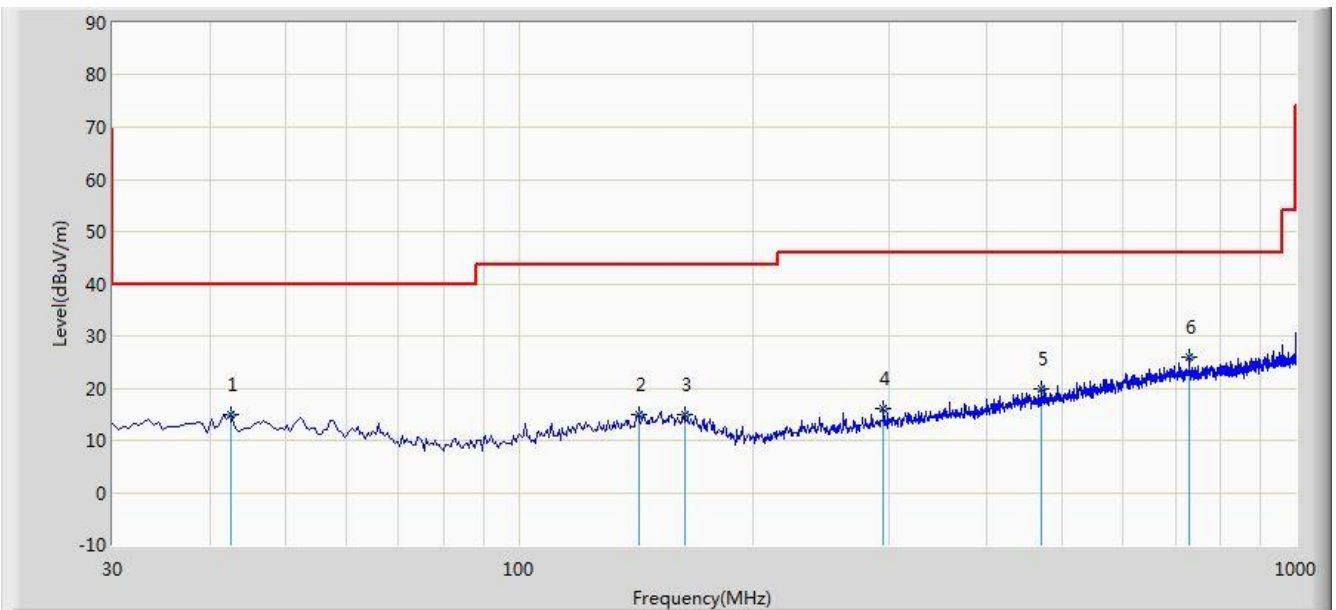

No	Flag	Mark	Frequency (MHz)	Measure Level (dBuV/m)	Reading Level (dBuV)	Margin (dB)	Limit (dBuV/m)	Factor (dB)	Type
1			42.610	14.866	0.343	-25.134	40.000	14.522	QP
2			142.520	14.796	-0.082	-28.704	43.500	14.877	QP
3			163.375	14.851	-0.251	-28.649	43.500	15.103	QP
4			294.325	16.001	1.614	-29.999	46.000	14.387	QP
5			470.380	19.742	1.404	-26.258	46.000	18.338	QP
6		*	728.400	26.024	3.180	-19.976	46.000	22.844	QP

Note 1: Measure Level (dB μ V/m) = Reading Level (dB μ V) + Factor (dB)

Factor (dB) = Cable Loss (dB) + Antenna Factor (dB/m)

Note 2: The test trace is same as the ambient noise and the amplitude of the emissions are attenuated more than 20dB below the permissible (the test frequency range: 9kHz ~ 30MHz, 18GHz ~ 25GHz), therefore no data appear in the report.

7.7. Radiated Restricted Band Edge Measurement

7.7.1. Test Limit

For 15.205 requirement:

Radiated emissions which fall in the restricted bands, as defined in Section 15.205(a) of FCC part 15, must also comply with the radiated emission limits specified in Section 15.209(a).

Frequency (MHz)	Frequency (MHz)	Frequency (MHz)	Frequency (GHz)
0.090 - 0.110	16.42 - 16.423	399.9 - 410	4.5 - 5.15
¹ 0.495 - 0.505	16.69475 - 16.69525	608 - 614	5.35 - 5.46
2.1735 - 2.1905	16.80425 - 16.80475	960 - 1240	7.25 - 7.75
4.125 - 4.128	25.5 - 25.67	1300 - 1427	8.025 - 8.5
4.17725 - 4.17775	37.5 - 38.25	1435 - 1626.5	9.0 - 9.2
4.20725 - 4.20775	73 - 74.6	1645.5 - 1646.5	9.3 - 9.5
6.215 - 6.218	74.8 - 75.2	1660 - 1710	10.6 - 12.7
6.26775 - 6.26825	108 - 121.94	1718.8 - 1722.2	13.25 - 13.4
6.31175 - 6.31225	123 - 138	2200 - 2300	14.47 - 14.5
8.291 - 8.294	149.9 - 150.05	2310 - 2390	15.35 - 16.2
8.362 - 8.366	156.52475 - 156.525	2483.5 - 2500	17.7 - 21.4
8.37625 - 8.38675	156.7 - 156.9	2690 - 2900	22.01 - 23.12
8.41425 - 8.41475	162.0125 - 167.17	3260 - 3267	23.6 - 24.0
12.29 - 12.293	167.72 - 173.2	3332 - 3339	31.2 - 31.8
12.51975 - 12.52025	240 - 285	3345.8 - 3358	36.43 - 36.5
12.57675 - 12.57725	322 - 335.4	3600 - 4400	(²)
13.36 - 13.41	--	--	--

All out of band emissions appearing in a restricted band as specified in Section 15.205 of the Title 47CFR must not exceed the limits shown in Table per Section 15.209.

FCC Part 15 Subpart C Paragraph 15.209		
Frequency [MHz]	Field Strength [uV/m]	Measured Distance [Meters]
0.009 - 0.490	2400/F (kHz)	300
0.490 - 1.705	24000/F (kHz)	30
1.705 - 30	30	30
30 - 88	100	3
88 - 216	150	3
216 - 960	200	3
Above 960	500	3

For RSS-Gen Section 8.10 requirement:

Radiated emissions which fall in the restricted bands, as defined in Section 8.10 of RSS-Gen, must also comply with the radiated emission limits specified in Section 8.9.

Frequency (MHz)	Frequency (MHz)	Frequency (GHz)
0.009 - 0.110	149.9 - 150.05	9.0 - 9.2
0.495 - 0.505	156.52475 - 156.525225	9.3 - 9.5
2.1735 - 2.1905	156.7 - 156.9	10.6 - 12.7
3.020 - 3.026	162.0125 - 167.17	13.25 - 13.4
4.125 - 4.128	167.72 - 173.2	14.47 - 14.5
4.17725 - 4.17775	240 - 285	15.35 - 16.2
4.20725 - 4.20775	322 - 335.4	17.7 - 21.4
5.677 - 5.683	399.9 - 410	22.01 - 23.12
6.215 - 6.218	608 - 614	23.6 - 24.0
6.26775 - 6.26825	960 - 1427	31.2 - 31.8
6.31175 - 6.31225	1435 - 1626.5	36.43 - 36.5
8.291 - 8.294	1645.5 - 1646.5	Above 38.6
8.362 - 8.366	1660 - 1710	--
8.37625 - 8.38675	1718.8 - 1722.2	
8.41425 - 8.41475	2200 - 2300	
12.29 - 12.293	2310 - 2390	
12.51975 - 12.52025	2483.5 - 2500	
12.57675 - 12.57725	2655 - 2900	
13.36 - 13.41	3260 - 3267	
16.42 - 16.423	3332 - 3339	
16.69475 - 16.69525	334.5 - 3358	
16.80425 - 16.80475	3500 - 4400	
25.5 - 25.67	4500 - 5150	
37.5 - 38.25	5350 - 5460	
73 - 74.6	7250 - 7750	
74.8 - 75.2	8025 - 8500	
108 - 138	--	

All out of band emissions appearing in a restricted band as specified in Section 8.10 of the RSS-Gen must not exceed the limits shown in Table per Section 8.9.

RSS-Gen Section 8.9		
Frequency [MHz]	Field Strength [uV/m]	Measured Distance [Meters]
0.009 - 0.490	2400/F (kHz)	300
0.490 - 1.705	24000/F (kHz)	30
1.705 - 30	30	30
30 - 88	100	3
88 - 216	150	3
216 - 960	200	3
Above 960	500	3

7.7.2. Test Procedure Used

ANSI C63.10 Section 6.3 (General Requirements)

ANSI C63.10 Section 6.6 (Standard test method above 1GHz)

7.7.3. Test Setting

Peak Field Strength Measurements

1. Analyzer center frequency was set to the frequency of the radiated spurious emission of interest
2. RBW = as specified in Table 1
3. VBW = 3MHz
4. Detector = peak
5. Sweep time = auto couple
6. Trace mode = max hold
7. Trace was allowed to stabilize

7.7.4. Test Setup

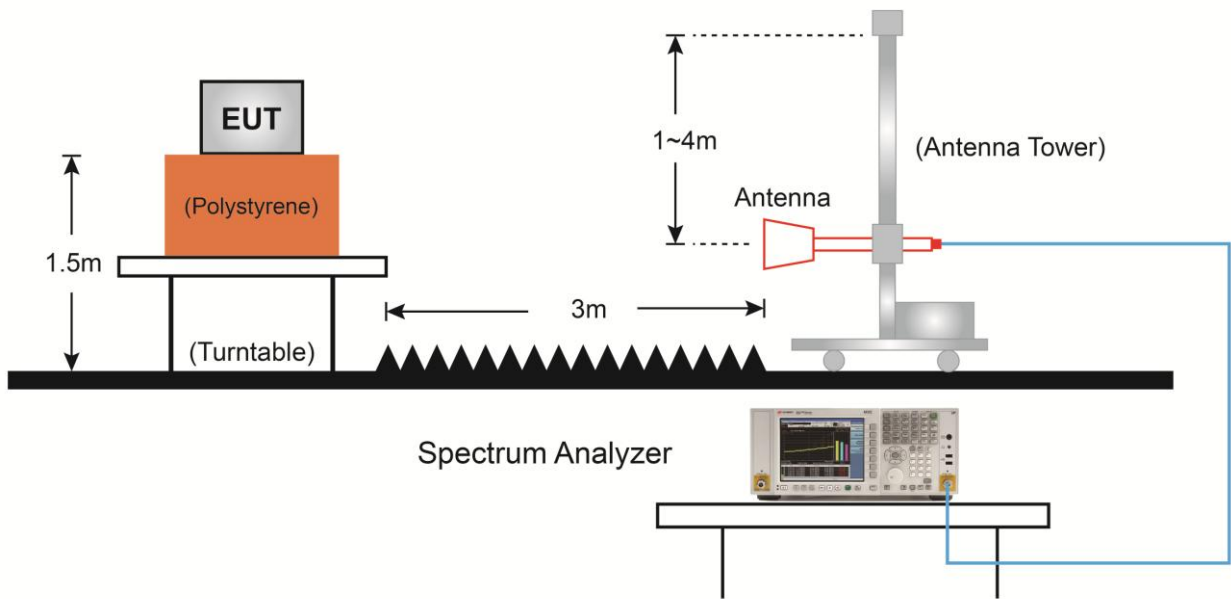

7.7.5. Test Result

Site: AC1	Time: 2019/04/24 - 04:11
Limit: FCC_Part15_Band Edge(3m)	Engineer: Dandy Li
Probe: BBHA9120D_1-18GHz	Polarity: Horizontal
EUT: Receiver	Power: By Battery
Test Mode: Transmit at Channel 2402MHz Ant A	

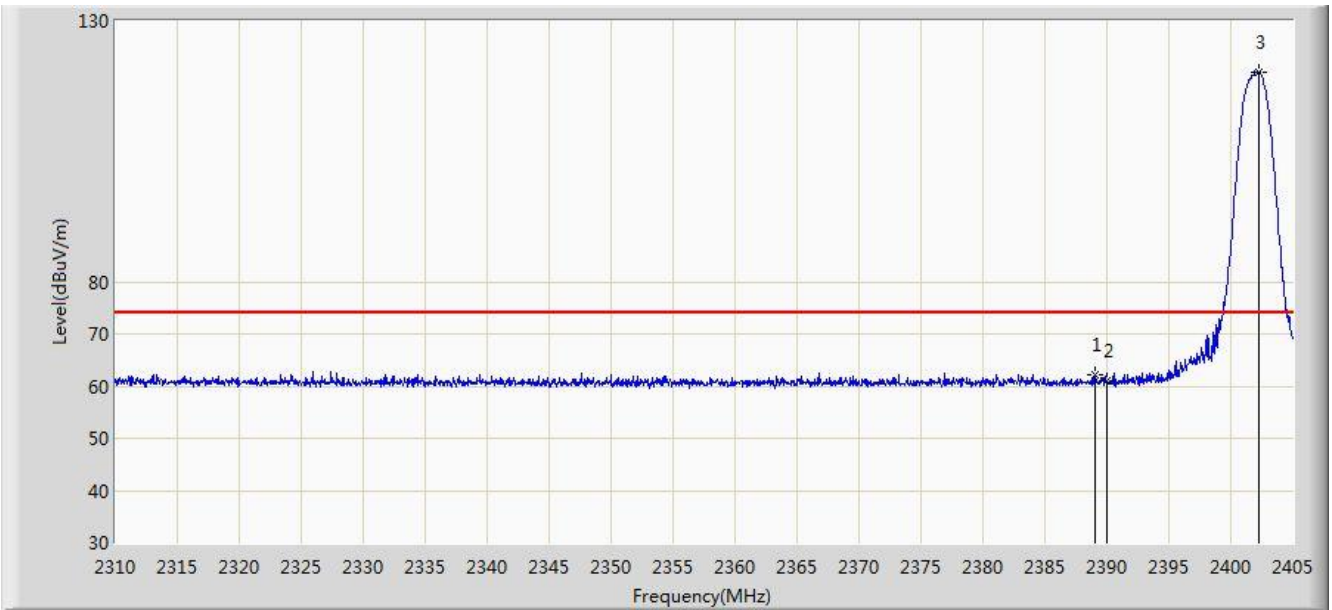

No	Flag	Mark	Frequency (MHz)	Reading Level (dBuV)	Factor (dB)	Duty Cycle Factor (dB)	Measure Level (dBuV/m)	Limit (dBuV/m)	Margin (dB)	Type
1			2389.040	29.854	32.414	N/A	62.268	74.000	-11.732	PK
			2389.040	29.854	32.414	-17.99	44.278	54.000	-9.722	AV
2			2390.000	28.524	32.413	N/A	60.937	74.000	-13.063	PK
			2390.000	28.524	32.413	-17.99	42.947	54.000	-11.053	AV
3		*	2402.292	87.825	32.396	N/A	120.221	N/A	N/A	PK

Note: Peak Measure Level (dB μ V/m) = Reading Level (dB μ V) + Factor (dB)

Average Measure Level = Peak Measure Level + Duty Cycle Factor

Factor (dB) = Cable Loss (dB) + Antenna Factor (dB/m)

Site: AC1	Time: 2019/04/24 - 04:15
Limit: FCC_Part15_Band Edge(3m)	Engineer: Dandy Li
Probe: BBHA9120D_1-18GHz	Polarity: Vertical
EUT: Receiver	Power: By Battery
Test Mode: Transmit at Channel 2402MHz Ant A	

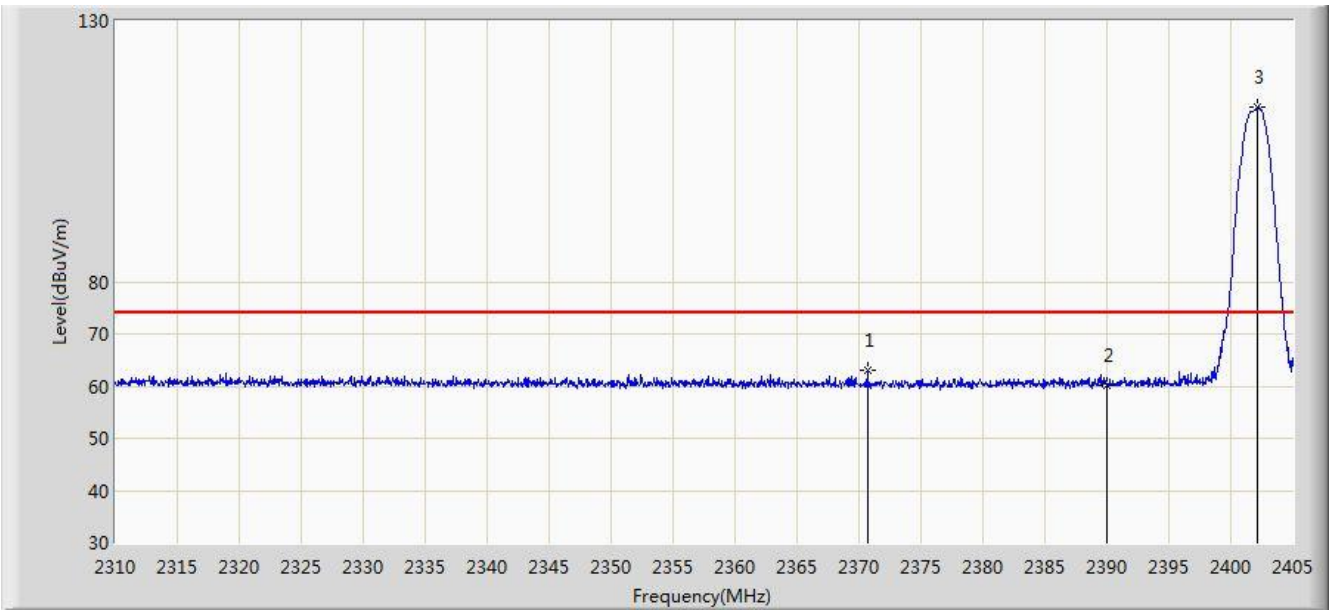

No	Flag	Mark	Frequency (MHz)	Reading Level (dBuV)	Factor (dB)	Duty Cycle Factor (dB)	Measure Level (dBuV/m)	Limit (dBuV/m)	Margin (dB)	Type
1			2370.657	30.610	32.451	N/A	63.061	74.000	-10.939	PK
			2370.657	30.610	32.451	-17.99	45.071	54.000	-8.929	AV
2			2390.000	27.851	32.413	N/A	60.264	74.000	-13.736	PK
			2390.000	27.851	32.413	-17.99	42.274	54.000	-11.726	AV
4		*	2402.198	80.99	32.396	N/A	113.386	N/A	N/A	PK

Note: Peak Measure Level (dB μ V/m) = Reading Level (dB μ V) + Factor (dB)

Average Measure Level = Peak Measure Level + Duty Cycle Factor

Factor (dB) = Cable Loss (dB) + Antenna Factor (dB/m)

Site: AC1	Time: 2019/04/24 - 04:17
Limit: FCC_Part15_Band Edge(3m)	Engineer: Dandy Li
Probe: BBHA9120D_1-18GHz	Polarity: Horizontal
EUT: Receiver	Power: By Battery
Test Mode: Transmit at Channel 2478MHz Ant A	

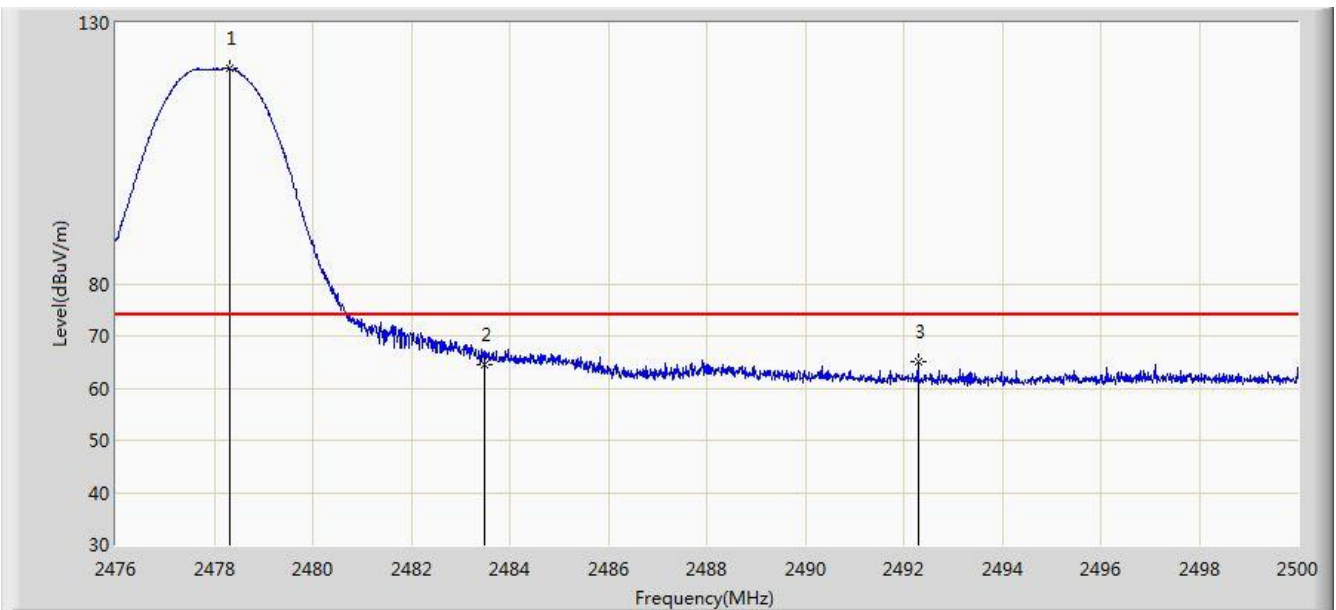

No	Flag	Mark	Frequency (MHz)	Reading Level (dBuV)	Factor (dB)	Duty Cycle Factor (dB)	Measure Level (dBuV/m)	Limit (dBuV/m)	Margin (dB)	Type
1		*	2478.304	88.808	32.405	N/A	121.213	N/A	N/A	PK
2			2483.500	32.094	32.416	N/A	64.510	74.000	-9.490	PK
			2483.500	32.094	32.416	-17.99	46.520	54.000	-7.480	AV
3			2492.296	32.541	32.433	N/A	64.974	74.000	-9.026	PK
			2492.296	32.541	32.433	-17.99	46.984	54.000	-7.016	AV

Note: Peak Measure Level (dB μ V/m) = Reading Level (dB μ V) + Factor (dB)

Average Measure Level = Peak Measure Level + Duty Cycle Factor

Factor (dB) = Cable Loss (dB) + Antenna Factor (dB/m)

Site: AC1	Time: 2019/04/24 - 04:20
Limit: FCC_Part15_Band Edge(3m)	Engineer: Dandy Li
Probe: BBHA9120D_1-18GHz	Polarity: Vertical
EUT: Receiver	Power: By Battery
Test Mode: Transmit at Channel 2478MHz Ant A	

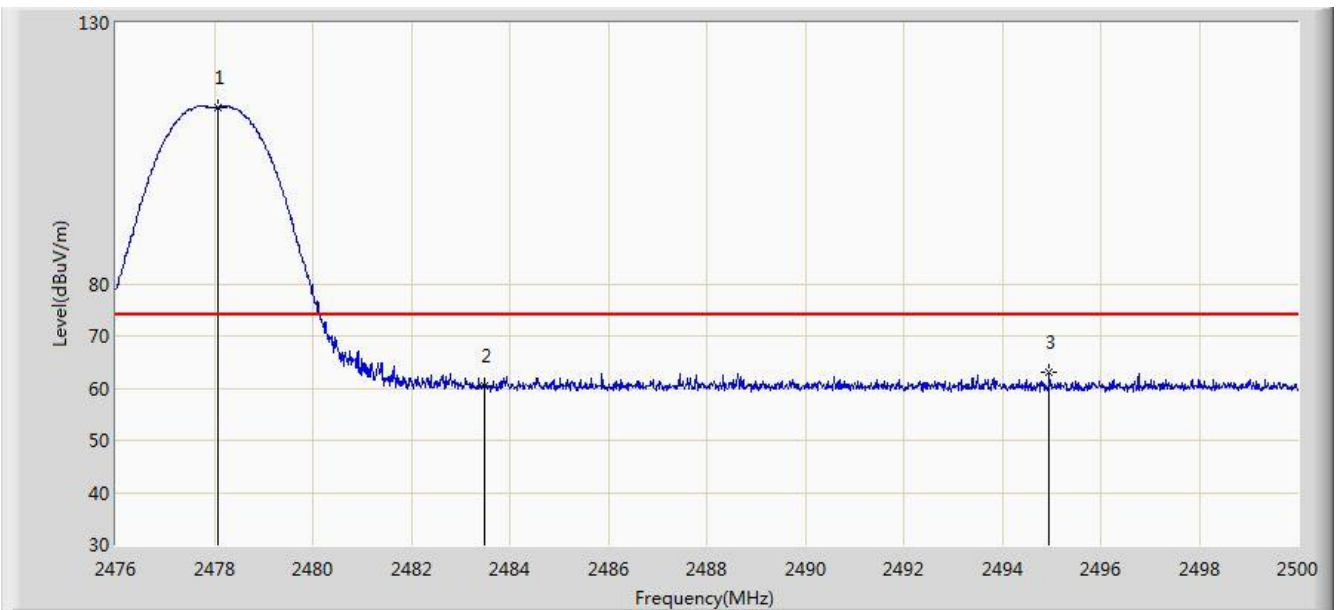

No	Flag	Mark	Frequency (MHz)	Reading Level (dBuV)	Factor (dB)	Duty Cycle Factor (dB)	Measure Level (dBuV/m)	Limit (dBuV/m)	Margin (dB)	Type
1		*	2478.076	81.439	32.404	N/A	113.843	N/A	N/A	PK
2			2483.500	27.905	32.416	N/A	60.321	74.000	-13.679	PK
			2483.500	27.905	32.416	-17.99	42.331	54.000	-11.669	AV
3			2494.960	30.521	32.438	N/A	62.959	74.000	-11.041	PK
			2494.960	30.521	32.438	-17.99	44.969	54.000	-9.031	AV

Note: Peak Measure Level (dBuV/m) = Reading Level (dBuV) + Factor (dB)

Average Measure Level = Peak Measure Level + Duty Cycle Factor

Factor (dB) = Cable Loss (dB) + Antenna Factor (dB/m)

Site: AC1	Time: 2019/04/24 - 04:22
Limit: FCC_Part15_Band Edge(3m)	Engineer: Dandy Li
Probe: BBHA9120D_1-18GHz	Polarity: Horizontal
EUT: Receiver	Power: By Battery
Test Mode: Transmit at Channel 2402MHz Ant B	

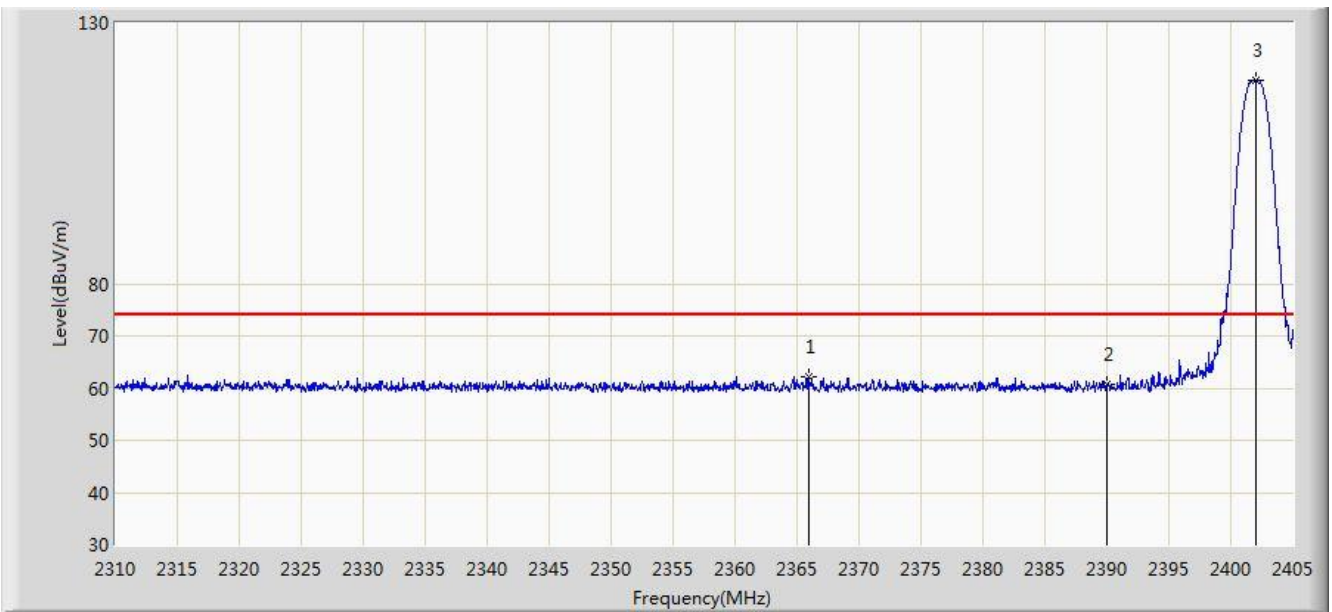

No	Flag	Mark	Frequency (MHz)	Reading Level (dBuV)	Factor (dB)	Duty Cycle Factor (dB)	Measure Level (dBuV/m)	Limit (dBuV/m)	Margin (dB)	Type
1			2366.002	29.788	32.461	N/A	62.249	74.000	-11.751	PK
			2366.002	29.788	32.461	-17.99	44.259	54.000	-9.741	AV
2			2390.000	28.284	32.413	N/A	60.697	74.000	-13.303	PK
			2390.000	28.284	32.413	-17.99	42.707	54.000	-11.293	AV
3		*	2402.008	86.509	32.396	N/A	118.905	N/A	N/A	PK

Note: Peak Measure Level (dB μ V/m) = Reading Level (dB μ V) + Factor (dB)

Average Measure Level = Peak Measure Level + Duty Cycle Factor

Factor (dB) = Cable Loss (dB) + Antenna Factor (dB/m)

Site: AC1	Time: 2019/04/24 - 04:25
Limit: FCC_Part15_Band Edge(3m)	Engineer: Dandy Li
Probe: BBHA9120D_1-18GHz	Polarity: Vertical
EUT: Receiver	Power: By Battery
Test Mode: Transmit at Channel 2402MHz Ant B	

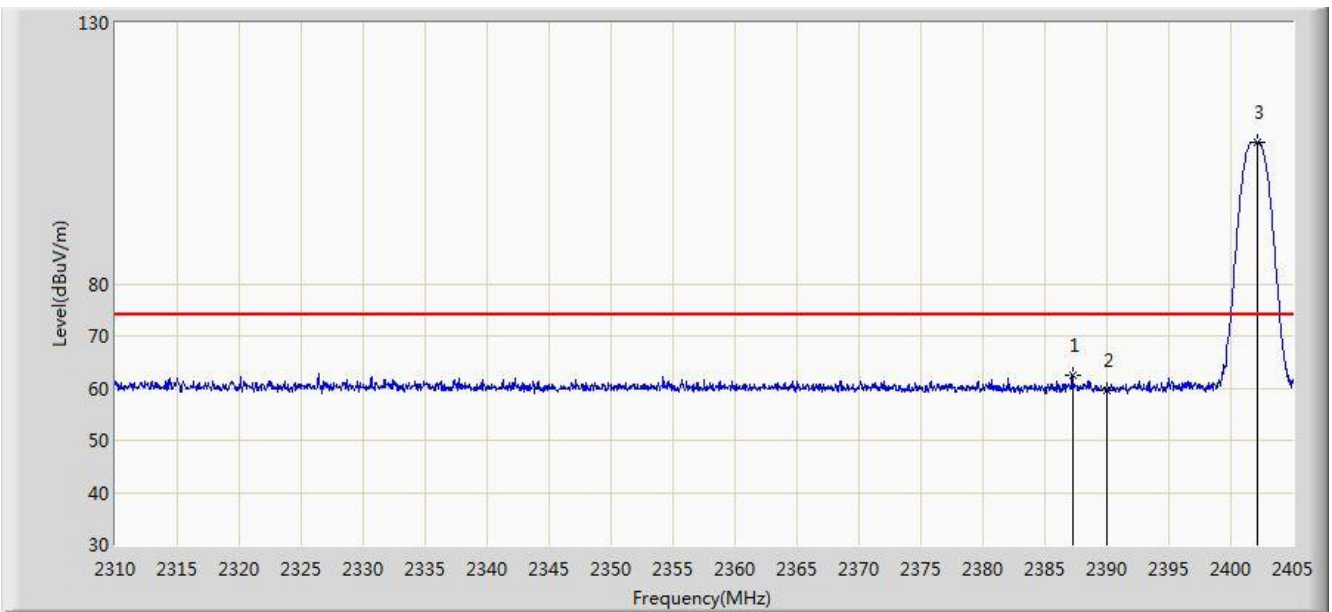

No	Flag	Mark	Frequency (MHz)	Reading Level (dBuV)	Factor (dB)	Duty Cycle Factor (dB)	Measure Level (dBuV/m)	Limit (dBuV/m)	Margin (dB)	Type
1			2387.235	30.106	32.418	N/A	62.524	74.000	-11.476	PK
			2387.235	30.106	32.418	-17.99	44.534	54.000	-9.466	AV
2			2390.000	27.183	32.413	N/A	59.596	74.000	-14.404	PK
			2390.000	27.183	32.413	-17.99	41.606	54.000	-12.394	AV
4		*	2402.150	74.704	32.396	N/A	107.1	N/A	N/A	PK

Note: Peak Measure Level (dB μ V/m) = Reading Level (dB μ V) + Factor (dB)

Average Measure Level = Peak Measure Level + Duty Cycle Factor

Factor (dB) = Cable Loss (dB) + Antenna Factor (dB/m)

Site: AC1	Time: 2019/04/24 - 04:27
Limit: FCC_Part15_Band Edge(3m)	Engineer: Dandy Li
Probe: BBHA9120D_1-18GHz	Polarity: Horizontal
EUT: Receiver	Power: By Battery
Test Mode: Transmit at Channel 2478MHz Ant B	

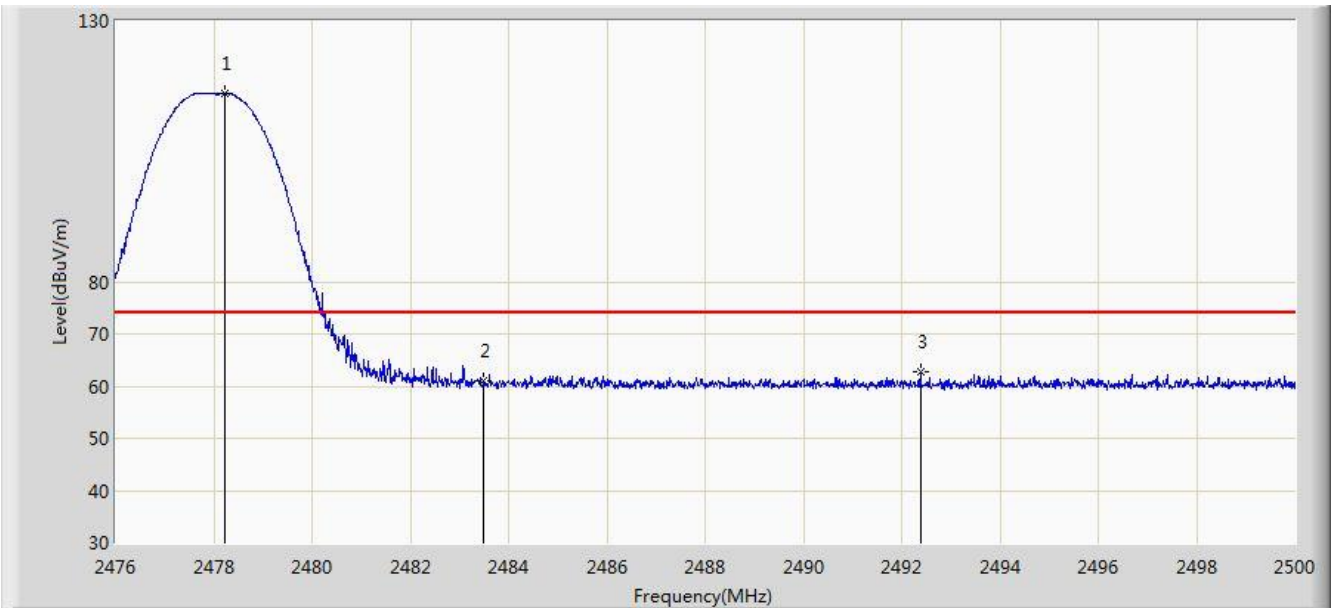

No	Flag	Mark	Frequency (MHz)	Reading Level (dBuV)	Factor (dB)	Duty Cycle Factor (dB)	Measure Level (dBuV/m)	Limit (dBuV/m)	Margin (dB)	Type
1		*	2478.232	83.658	32.405	N/A	116.063	N/A	N/A	PK
2			2483.500	28.520	32.416	N/A	60.936	74.000	-13.064	PK
			2483.500	28.520	32.416	-17.99	42.946	54.000	-11.054	AV
3			2492.380	30.435	32.433	N/A	62.868	74.000	-11.132	PK
			2492.380	30.435	32.433	-17.99	44.878	54.000	-9.122	AV

Note: Peak Measure Level (dB μ V/m) = Reading Level (dB μ V) + Factor (dB)

Average Measure Level = Peak Measure Level + Duty Cycle Factor

Factor (dB) = Cable Loss (dB) + Antenna Factor (dB/m)

Site: AC1	Time: 2019/04/24 - 04:30
Limit: FCC_Part15_Band Edge(3m)	Engineer: Dandy Li
Probe: BBHA9120D_1-18GHz	Polarity: Vertical
EUT: Receiver	Power: By Battery
Test Mode: Transmit at Channel 2478MHz via Ant B	

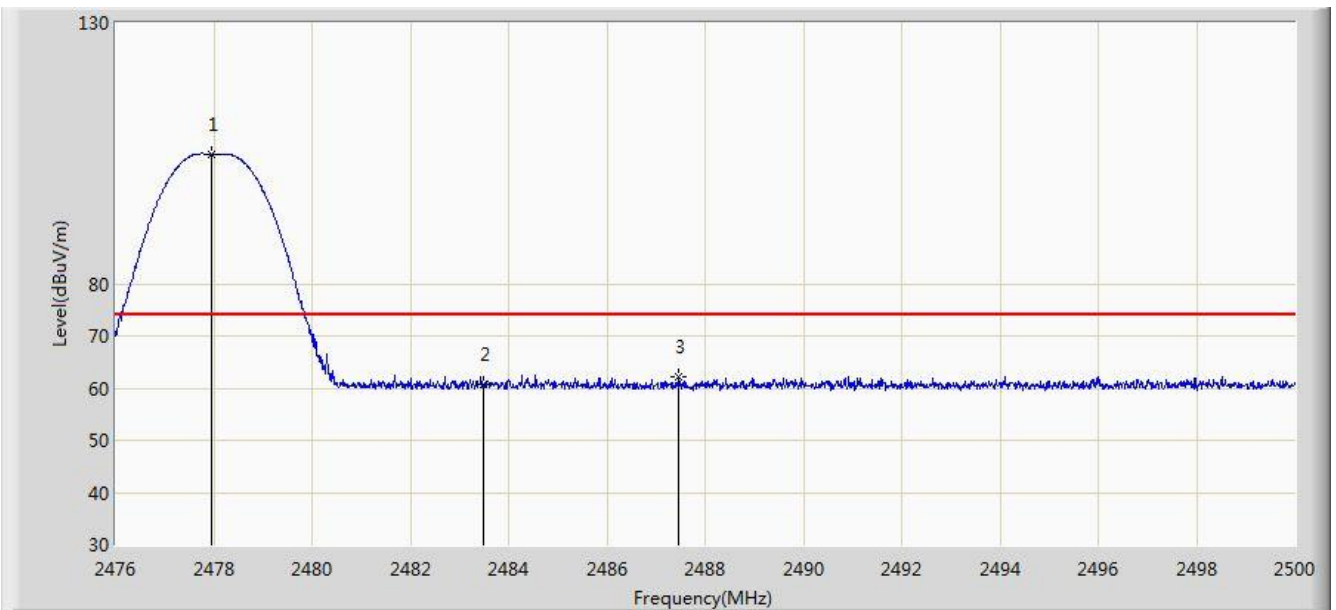

No	Flag	Mark	Frequency (MHz)	Reading Level (dBuV)	Factor (dB)	Duty Cycle Factor (dB)	Measure Level (dBuV/m)	Limit (dBuV/m)	Margin (dB)	Type
1		*	2477.968	72.394	32.404	N/A	104.798	N/A	N/A	PK
2			2483.500	28.233	32.416	N/A	60.649	74.000	-13.351	PK
			2483.500	28.233	32.416	-17.99	42.659	54.000	-11.341	AV
3			2487.460	29.793	32.423	N/A	62.216	74.000	-11.784	PK
			2487.460	29.793	32.423	-17.99	44.226	54.000	-9.774	AV

Note: Peak Measure Level (dB μ V/m) = Reading Level (dB μ V) + Factor (dB)

Average Measure Level = Peak Measure Level + Duty Cycle Factor

Factor (dB) = Cable Loss (dB) + Antenna Factor (dB/m)

7.8. AC Conducted Emissions Measurement

7.8.1. Test Limit

FCC Part 15 Subpart C Paragraph 15.207 Limits		
Frequency (MHz)	QP (dBuV)	AV (dBuV)
0.15 ~ 0.50	66 ~ 56	56 ~ 46
0.50 ~ 5.0	56	46
5.0 ~ 30	60	50

Note 1: The lower limit shall apply at the transition frequencies.

Note 2: The limit decreases linearly with the logarithm of the frequency in the range 0.15MHz to 0.5MHz.

7.8.2. Test Setup

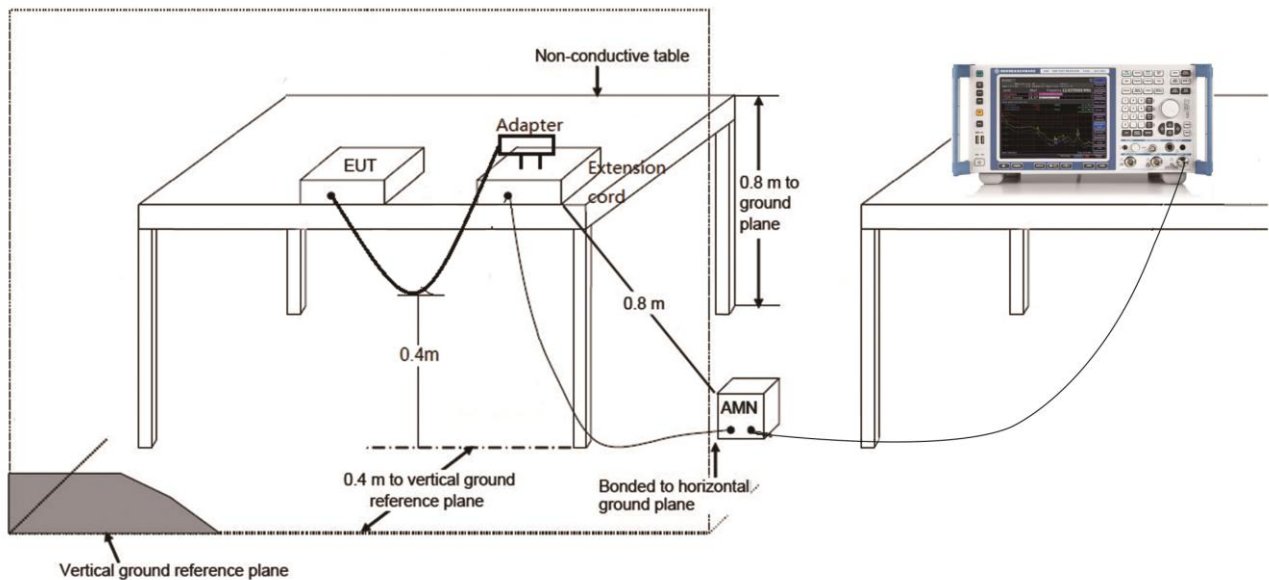

7.8.3. Test Result

The EUT is powered by battery, so this requirement does not apply.

8. CONCLUSION

The data collected relate only the item(s) tested and show that the device is in compliance with Part 15C of the FCC Rules and ISED Rules.

_____ The End _____

Appendix A - Test Setup Photograph

Refer to "1904RSU006-UT" file.

Appendix B - EUT Photograph

Refer to “ 1904RSU006-UE” file.