

MEASUREMENT REPORT

FCC PART 15.247 / ISED RSS-247

FCC ID: BRWSPMSLT200F
IC: 6157A-SPMSLT200F
Applicant: Horizon Hobby, LLC

Application Type: Certification
Product: SLT2 2CH TX
Model No. (HVIN): SPMSLT200F
Brand Name: Spektrum
FCC Classification: Digital Transmission System (DTS)
FCC Rule Part(s): Part15 Subpart C (Section 15.247)
ISED Rule(s): RSS-247 Issue 2, RSS-GEN Issue 5
Test Procedure(s): ANSI C63.10-2013, KDB 558074 D01v05r02
Test Date: September 02 ~ October 28, 2021

Reviewed By:

Jame Yuan

Approved By:

Robin Wu



The test results relate only to the samples tested.

This equipment has been shown to be capable of compliance with the applicable technical standards as indicated in the measurement report and was tested in accordance with the measurement procedures specified in ANSI C63.10-2013. Test results reported herein relate only to the item(s) tested.

The test report shall not be reproduced except in full without the written approval of MRT Technology (Suzhou) Co., Ltd.

Revision History

Report No.	Version	Description	Issue Date	Note
2108RSU036-U2	Rev. 01	Initial Report	11-30-2021	Valid

CONTENTS

Description	Page
1. General Information	5
1.1. Applicant.....	5
1.2. Manufacturer	5
1.3. Testing Facility	5
1.4. Product Information	6
1.5. Working Frequencies	6
1.6. Test Mode	7
1.7. Configuration of Test System	7
1.8. Test Environment Condition.....	7
1.9. Description of Duty Cycle during normal operation	8
1.10. EMI Suppression Device(s)/Modifications.....	8
1.11. Labelling Requirements.....	9
2. ANTENNA REQUIREMENTS	10
3. TEST EQUIPMENT CALIBRATION DATE	11
4. MEASUREMENT UNCERTAINTY	13
5. TEST RESULT	14
5.1. Summary	14
5.2. Occupied Bandwidth Measurement	15
5.2.1. Test Limit.....	15
5.2.2. Test Procedure used.....	15
5.2.3. Test Setting	15
5.2.4. Test Setup	16
5.2.5. Test Result	17
5.3. Output Power Measurement	19
5.3.1. Test Limit.....	19
5.3.2. Test Procedure Used	19
5.3.3. Test Setting	19
5.3.4. Test Setup	20
5.3.5. Test Result	21
5.4. Power Spectral Density Measurement	22
5.4.1. Test Limit.....	22
5.4.2. Test Procedure Used	22
5.4.3. Test Setting	22
5.4.4. Test Setup	22
5.4.5. Test Result	23
5.5. Conducted Band Edge and Out-of-Band Emissions.....	24
5.5.1. Test Limit.....	24

5.5.2. Test Procedure Used	24
5.5.3. Test Setting	24
5.5.4. Test Setup	25
5.5.5. Test Result	26
5.6. Radiated Spurious Emission Measurement	29
5.6.1. Test Limit	29
5.6.2. Test Procedure Used	29
5.6.3. Test Setting	29
5.6.4. Test Setup	31
5.6.5. Test Result	32
5.7. Radiated Restricted Band Edge Measurement	38
5.7.1. Test Limit	38
5.7.2. Test Procedure Used	41
5.7.3. Test Setting	41
5.7.4. Test Setup	42
5.7.5. Test Result	43
5.8. AC Conducted Emissions Measurement.....	49
5.8.1. Test Limit	49
5.8.2. Test Setup	49
5.8.3. Test Result	49
6. CONCLUSION	50
Appendix A - Test Setup Photograph	51
Appendix B - EUT Photograph.....	52

1.4. Product Information

Product Name	SLT2 2CH TX
Model No. (HVIN)	SPMSLT200F
PMN	SPMSLT200
Brand Name	Spektrum
Frequency Range	2410MHz ~ 2480MHz
Modulation	GFSK
Number of Channels	57
Antenna Type	Monopole Antenna
Antenna Gain	3 dBi
Data Rate	250kbps
Working Voltage	4*AA Battery
Operating Temp.	-10 ~ 55°C

Note: The information of EUT was provided by the manufacturer, and the accuracy of the information shall be the responsibility of the manufacturer.

1.5. Working Frequencies

Channel	Frequency	Channel	Frequency	Channel	Frequency	Channel	Frequency
01	2410MHz	02	2411MHz	03	2412MHz	04	2413MHz
05	2414MHz	06	2415MHz	07	2416MHz	08	2417MHz
09	2418MHz	10	2419MHz	11	2420MHz	12	2421MHz
13	2422MHz	14	2423MHz	15	2424MHz	16	2425MHz
17	2426MHz	18	2427MHz	19	2428MHz	20	2429MHz
21	2430MHz	22	2431 MHz	23	2432 MHz	24	2433 MHz
25	2434 MHz	26	2435 MHz	27	2436 MHz	28	2437 MHz
29	2438 MHz	30	2439 MHz	31	2440 MHz	32	2441 MHz
33	2442 MHz	34	2443 MHz	35	2444 MHz	36	2445 MHz
37	2446 MHz	38	2447 MHz	39	2448 MHz	40	2449 MHz
41	2450 MHz	42	2451 MHz	43	2452 MHz	44	2453 MHz
45	2454 MHz	46	2455 MHz	47	2456 MHz	48	2457 MHz
49	2458 MHz	50	2459 MHz	51	2460 MHz	52	2461 MHz
53	2462 MHz	54	2463 MHz	55	2464 MHz	56	2465 MHz
57	2480 MHz	--	--	--	--	--	--

1.6. Test Mode

Test Mode	Mode 1: Transmit by GFSK
-----------	--------------------------

1.7. Configuration of Test System

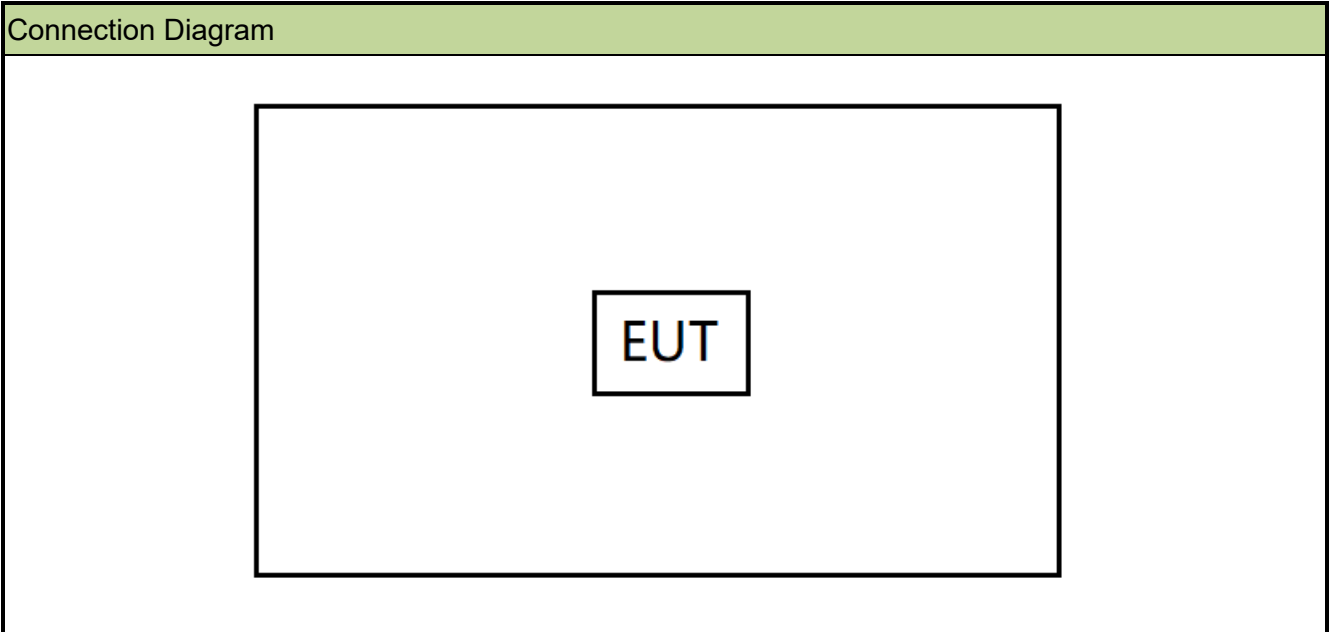

Note: The engineer test sample was provided by the manufacturer, it was configured into fixed frequency transmitter status after power on.

1.8. Test Environment Condition

Ambient Temperature	15 ~ 35°C
Relative Humidity	20 ~ 75%RH

1.9. Description of Duty Cycle during normal operation

Data Channel	Advertising Channel
2410-2465MHz with each 1MHz interval	2480MHz

Each EUT will use 15 data channels selected from 2410-2465MHz and one advertising channel 2480MHz.

Once the EUT matched with receiver via 2480MHz channel, it will use 15 hopping channels to transfer data with receiver and emit cyclically in a fixed hopping sequence, each channel's transmit time interval is 6ms.

One pulse "ON time" = 450.9 us + 450.9 us = 901.8 us.

The pulse train = 6ms * 15 = 90ms.

Duty Cycle = 901.8 us / 90 ms * 1000 = 0.01.

Duty Cycle Factor = 20*log (Duty Cycle) = -40.

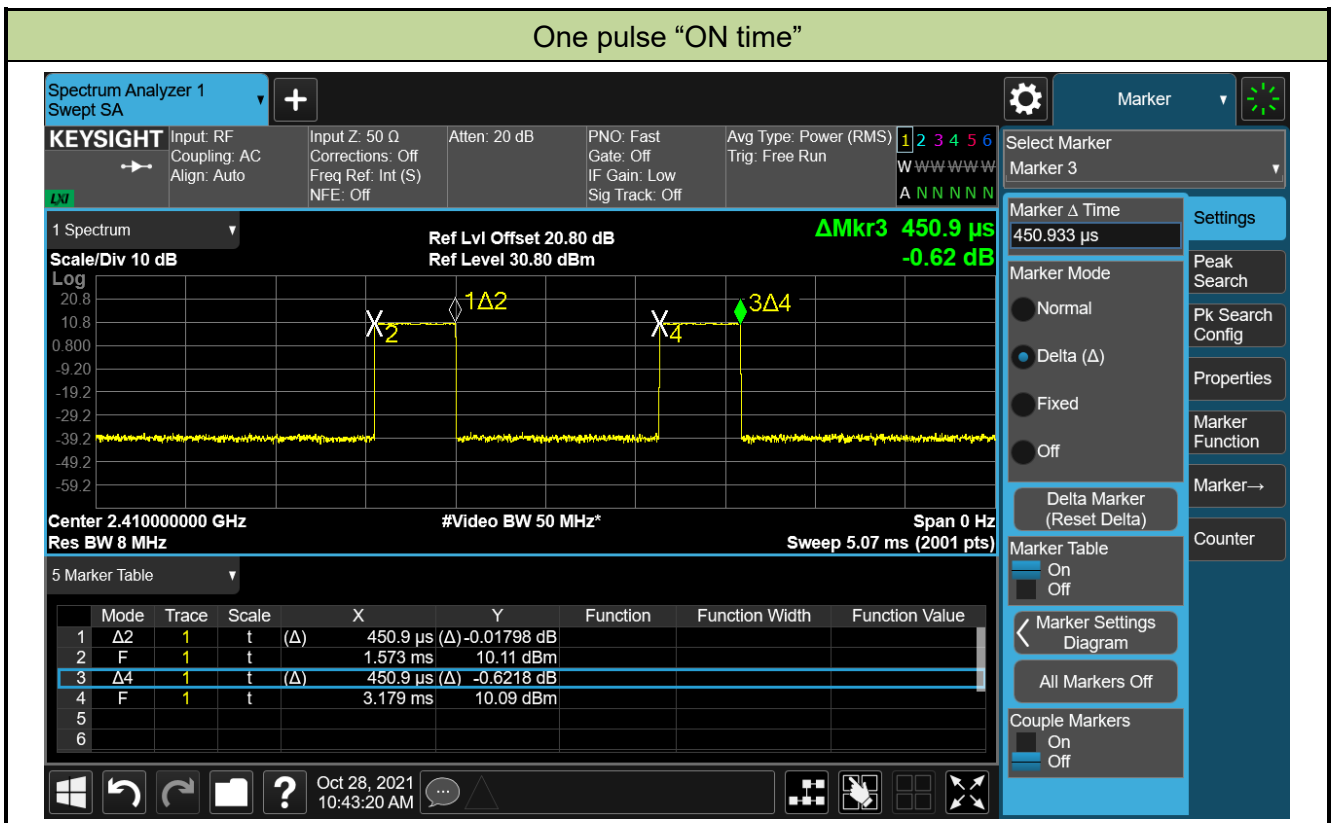

1.10. EMI Suppression Device(s)/Modifications

No EMI suppression device(s) were added and/or no modifications were made during testing.

1.11. Labelling Requirements

Per 2.1074 & 15.19; Docket 95-19

The label shall be permanently affixed at a conspicuous location on the device; instruction manual or pamphlet supplied to the user and be readily visible to the purchaser at the time of purchase.

However, when the device is so small wherein placement of the label with specified statement is not practical, only the FCC ID must be displayed on the device per Section 15.19(a)(5). Please see attachment for FCC ID label and label location.

RSS-Gen Issue 5 Section 4

In addition to complying with the applicable RSSs and RSP-100, each unit of a product model (i.e. of a radio apparatus) shall meet the labelling requirements set out in this section prior to being marketed in Canada or imported into Canada.

For information regarding the labelling option, see Section 4.1, 4.2, 4.3 4.4. The label for the certified product represents the manufacturer's or importer's compliance with Innovation, Science and Economic Development Canada's (ISED) regulatory requirements.

Please see attachment for IC label and label location.

2. ANTENNA REQUIREMENTS

Excerpt from §15.203 of the FCC Rules/Regulations:

“An intentional radiator antenna shall be designed to ensure that no antenna other than that furnished by the responsible party can be used with the device. The use of a permanently attached antenna or of an antenna that uses a unique coupling to the intentional radiator shall be considered sufficient to comply with the provisions of this section.”

Conclusion:

The unit complies with the requirement of §15.203.

3. TEST EQUIPMENT CALIBRATION DATE

Conducted Emission (WZ-SR2)

Instrument	Manufacturer	Type No.	Asset No.	Cali. Interval	Cali. Due Date
EMI Test Receiver	R&S	ESR3	MRTSUE06185	1 year	2022/01/12
Two-Line V-Network	R&S	ENV216	MRTSUE06002	1 year	2022/06/08
Thermal Hygrometer	testo	608-H1	MRTSUE06404	1 year	2022/06/28
Shielding Room	MIX-BEP	Chamber-SR2	MRTSUE06215	N/A	N/A

Radiated Emission (WZ-AC1)

Instrument	Manufacturer	Type No.	Asset No.	Cali. Interval	Cali. Due Date
EMI Test Receiver	R&S	ESR7	MRTSUE06001	1 year	2022/01/04
PXA Signal Analyzer	Keysight	N9030B	MRTSUE06395	1 year	2022/07/29
Loop Antenna	Schwarzbeck	FMZB 1519	MRTSUE06025	1 year	2021/11/08
Bilog Period Antenna	Schwarzbeck	VULB 9168	MRTSUE06172	1 year	2022/08/05
Horn Antenna	Schwarzbeck	BBHA 9120D	MRTSUE06023	1 year	2021/09/27 2022/09/16
Horn Antenna	Schwarzbeck	BBHA9170	MRTSUE06597	1 year	2021/12/14
Microwave System Amplifier	Agilent	83017A	MRTSUE06076	1 year	2021/11/14
Preamplifier	Schwarzbeck	BBV 9721	MRTSUE06121	1 year	2022/06/09
Thermal Hygrometer	testo	608-H1	MRTSUE06403	1 year	2022/06/28
Anechoic Chamber	TDK	Chamber-AC1	MRTSUE06212	1 year	2022/04/29

Radiated Emission (WZ-AC2)

Instrument	Manufacturer	Type No.	Asset No.	Cali. Interval	Cali. Due Date
MXE EMI Receiver	Keysight	N9038A	MRTSUE06125	1 year	2022/06/24
Loop Antenna	Schwarzbeck	FMZB 1519	MRTSUE06025	1 year	2021/11/08
Bilog Period Antenna	Schwarzbeck	VULB 9162	MRTSUE06022	1 year	2022/05/24
Horn Antenna	Schwarzbeck	BBHA 9120D	MRTSUE06023	1 year	2021/09/27 2022/09/16
Horn Antenna	Schwarzbeck	BBHA9170	MRTSUE06597	1 year	2021/12/14
Broadband Coaxial Preamplifier	Schwarzbeck	BBV 9718	MRTSUE06176	1 year	2021/11/14
Preamplifier	Schwarzbeck	BBV 9721	MRTSUE06121	1 year	2022/06/09
Thermal Hygrometer	Minggao	ETH529	MRTSUE06170	1 year	2021/12/08
Anechoic Chamber	RIKEN	Chamber-AC2	MRTSUE06213	1 year	2022/04/29

Conducted Test Equipment (WZ-TR3)

Instrument	Manufacturer	Type No.	Asset No.	Cali. Interval	Cali. Due Date
EXA Signal Analyzer	Agilent	N9020A	MRTSUE06106	1 year	2022/04/13
EXA Signal Analyzer	Keysight	N9010B	MRTSUE06607	1 year	2022/01/07
Signal Analyzer	R&S	FSV40	MRTSUE06218	1 year	2022/04/13
Power Meter	Agilent	U2021XA	MRTSUE06030	1 year	2021/10/22 2022/10/10
USB wideband power sensor	Keysight	U2021XA	MRTSUE06446	1 year	2022/06/08
USB wideband power sensor	Keysight	U2021XA	MRTSUE06447	1 year	2022/06/08
Bluetooth Test Set	Anritsu	MT8852B-042	MRTSUE06389	1 year	2022/06/08
Audio Analyzer	Agilent	U8903B	MRTSUE06143	1 year	2022/05/19
Modulation Analyzer	HP	HP8901A	MRTSUE06098	1 year	2021/09/26 2022/09/12
Wideband Radio Communication Tester	R&S	CMW 500	MRTSUE06243	1 year	2021/10/20 2022/10/10
Attenuator	MVE	3dB	MRTSUE06529	1 year	2021/12/12
Attenuator	MVE	6dB	MRTSUE06534	1 year	2021/12/12
Attenuator	MVE	10dB	MRTSUE06540	1 year	2021/12/12
Attenuator	MVE	20dB	MRTSUE06547	1 year	2021/12/12
DC Power Supply	GWINSTEK	DPS-3303C	MRTSUE06064	N/A	N/A
Temperature & Humidity Chamber	BAOYT	BYH-150CL	MRTSUE06051	1 year	2021/10/22 2022/10/10
Thermal Hygrometer	testo	608-H1	MRTSUE06401	1 year	2022/06/28

Software	Version	Function
EMI Software	V3	EMI Test Software

4. MEASUREMENT UNCERTAINTY

Where relevant, the following test uncertainty levels have been estimated for tests performed on the EUT as specified in CISPR 16-4-2. This uncertainty represents an expanded uncertainty expressed at approximately the 95% confidence level using a coverage factor of $k = 2$.

Conducted Emission Measurement
Measurement Uncertainty for a Level of Confidence of 95% ($U=2Uc(y)$): 9kHz~150kHz: 3.74dB 150kHz~30MHz: 3.44dB
Radiated Disturbance
Measurement Uncertainty for a Level of Confidence of 95% ($U=2Uc(y)$): Horizontal: 9KHz~300MHz: 5.04dB 300MHz~1GHz: 4.95dB 1GHz~6GHz: 6.40dB Vertical: 9KHz~300MHz: 5.24dB 300MHz~1GHz: 6.03dB 1GHz~40GHz: 6.40dB
Spurious Emissions, Conducted
Measuring Uncertainty for a Level of Confidence of 95% ($U=2Uc(y)$): 0.78dB
Output Power
Measuring Uncertainty for a Level of Confidence of 95% ($U=2Uc(y)$): 1.13dB
Power Spectrum Density
Measuring Uncertainty for a Level of Confidence of 95% ($U=2Uc(y)$): 1.15dB
Occupied Bandwidth
Measuring Uncertainty for a Level of Confidence of 95% ($U=2Uc(y)$): 0.28%

5. TEST RESULT

5.1. Summary

FCC Section(s)	ISED Section(s)	Test Description	Test Limit	Test Condition	Test Result	Reference
15.247(a)(2)	RSS-247 [5.2]	6dB Bandwidth	$\geq 500\text{kHz}$	Conducted	Pass	Section 5.2
N/A	RSS-Gen [6.7]	99% Bandwidth	N/A		NA	
15.247(b)(3)	RSS-247 [5.4(d)]	Output Power	$\leq 1\text{Watt (30dBm)}$ & $\text{EIRP} \leq 4\text{Watt (36dBm)}$		Pass	Section 5.3
15.247(e)	RSS-247 [5.2]	Power Spectral Density	$\leq 8\text{dBm/3kHz}$		Pass	Section 5.4
15.247(d)	RSS-247 [5.5]	Band Edge / Out-of-Band Emissions	20dBc		Pass	Section 5.5
15.205 15.209	RSS-247 [5.5]	General Field Strength Limits (Restricted Bands and Radiated Emission Limits)	Emissions in restricted bands must meet the radiated limits detailed in 15.209	Radiated	Pass	Section 5.6 & 5.7
15.207	RSS-Gen [8.8]	AC Conducted Emissions 150kHz - 30MHz	$< \text{FCC 15.207 limits}$	Line Conducted	N/A	Section 5.8

Notes:

- 1) For radiated emission test, every axis (X, Y, Z) was also verified. The test results shown in the following sections represent the worst-case emissions.
- 2) The analyzer plots shown in this section were all taken with a correction table loaded into the analyzer. The correction table was used to account for the losses of the cables and attenuators used as part of the system to connect the EUT to the analyzer at all frequencies of interest.
- 3) N/A means test item is not applicable

5.2. Occupied Bandwidth Measurement

5.2.1. Test Limit

The minimum 6dB bandwidth shall be at least 500 kHz.

5.2.2. Test Procedure used

ANSI C63.10-2013 - Section 11.8 (6dB bandwidth)

ANSI C63.10-2013 - Section 6.9.3 (99% bandwidth)

5.2.3. Test Setting

For 6dB bandwidth

1. The Spectrum's automatic bandwidth measurement capability was used to perform the 6dB bandwidth measurement. The "X" dB bandwidth parameter was set to $X = 6$. The bandwidth measurement was not influenced by any intermediate power nulls in the fundamental emission.
2. Set RBW = 100 kHz
3. $VBW \geq 3 \times RBW$
4. Detector = Peak
5. Trace mode = Max hold
6. Sweep = Auto couple
7. Allow the trace was allowed to stabilize

For 99% bandwidth

1. Span = 1.5 times to 5 times the OBW
2. Set RBW = 1% to 5% the OBW
3. $VBW \geq 3 \times RBW$
4. Detector = Peak
5. Trace mode = Max hold
6. Sweep = Auto couple
7. Allow the trace was allowed to stabilize

5.2.4. Test Setup

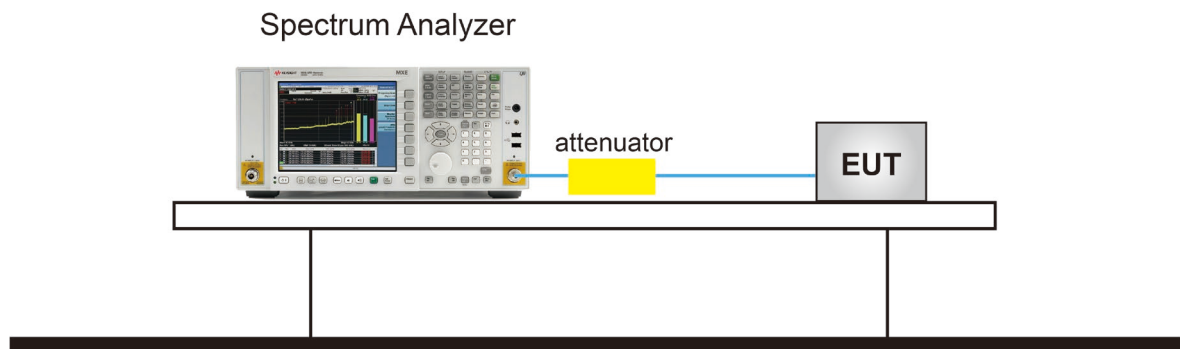

5.2.5. Test Result

Test Site	WZ-TR3	Test Engineer	Luis Yang
Test Date	2021/10/26		

Test Mode	Channel No.	Frequency (MHz)	6dB Bandwidth (KHz)	Limit (kHz)	99% Bandwidth (kHz)	Result
GFSK	01	2410	551.9	≥ 500	692.76	Pass
GFSK	29	2438	550.0	≥ 500	675.67	Pass
GFSK	56	2465	549.5	≥ 500	678.62	Pass
GFSK	57	2480	549.2	≥ 500	736.08	Pass

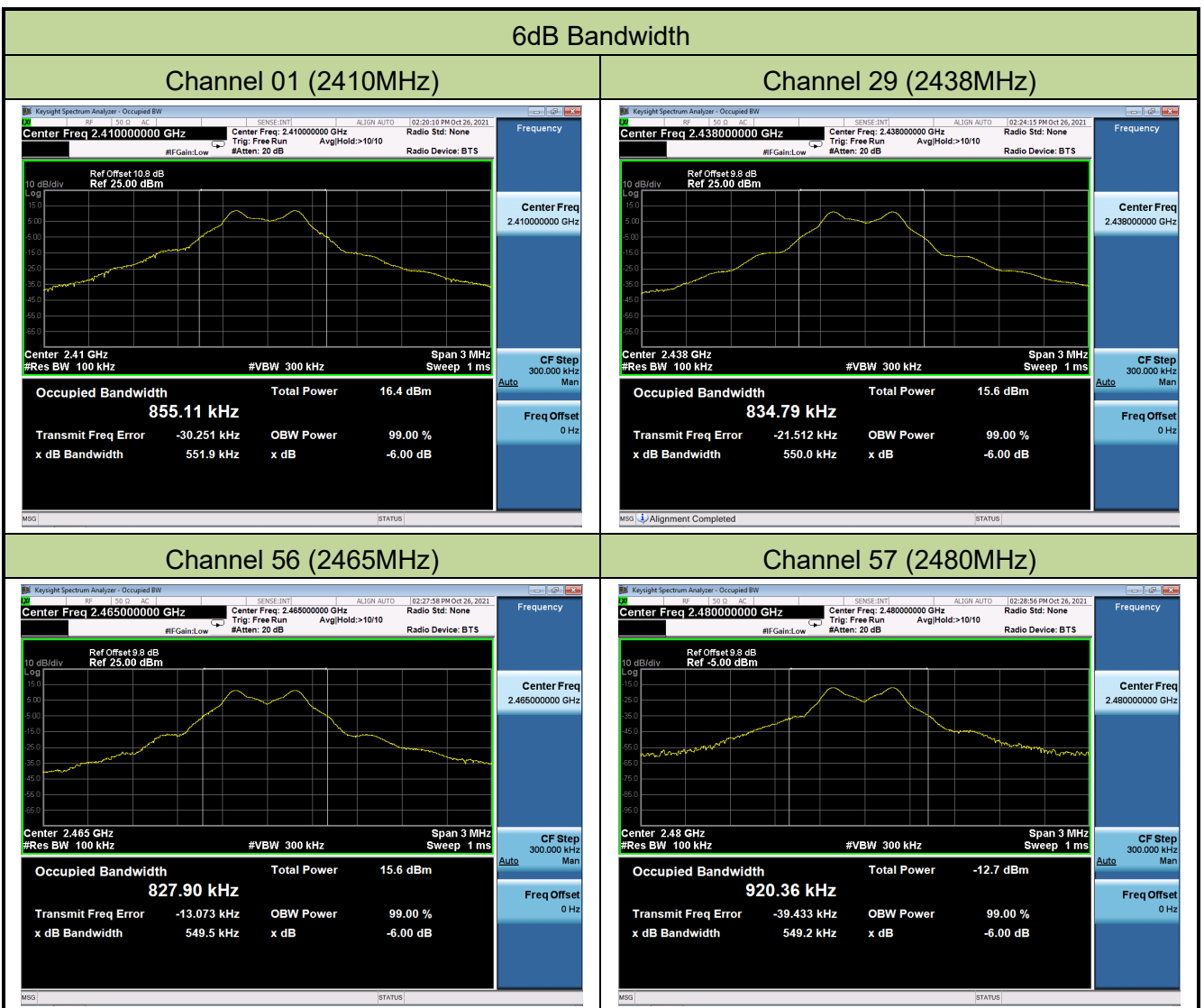

99% Bandwidth

Channel 01 (2410MHz)

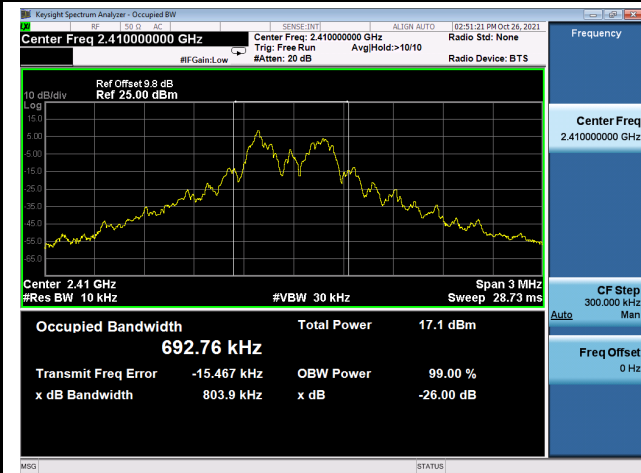

Channel 29 (2438MHz)



Channel 56 (2465MHz)

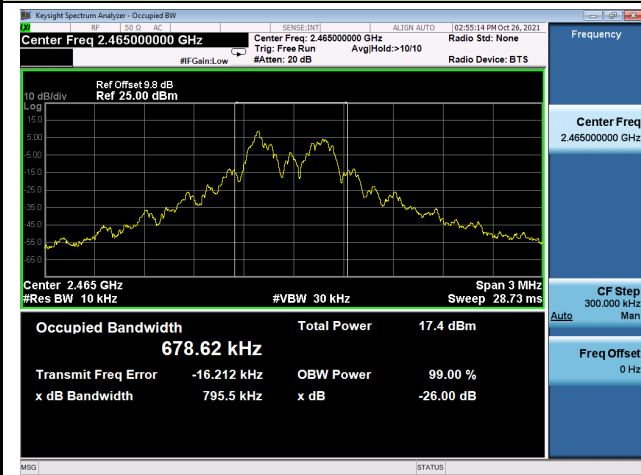

Channel 57 (2480MHz)

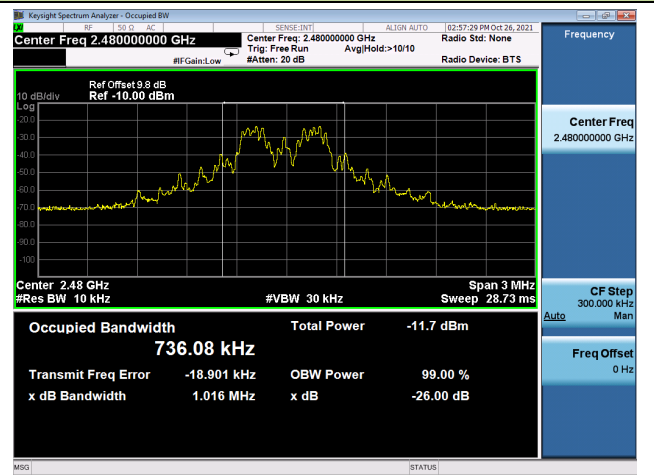

5.3. Output Power Measurement

5.3.1. Test Limit

The maximum out power shall be less 1 Watt (30dBm) and the E.I.R.P shall not exceed 4 Watt (36dBm).

The conducted output power limit specified in paragraph FCC Part 15.247(b) of this section is based on the use of antennas with directional gains that do not exceed 6 dBi. If transmitting antennas of directional gain greater than 6 dBi are used, the conducted output power from the intentional radiator shall be reduced below the stated values in paragraphs FCC Part 15.247(b)(3) of this section, as appropriate, by the amount in dB that the directional gain of the antenna exceeds 6 dBi.

5.3.2. Test Procedure Used

ANSI C63.10-2013 - Section 11.9.1.3 PKPM1 Peak-reading power meter method

ANSI C63.10-2013 - Section 11.9.2.3.2 Method AVGPM-G

5.3.3. Test Setting

Method PKPM1 (Peak power measurement)

Peak power measurements were performed only when the EUT was transmitting at its maximum power control level using a broadband power meter with a pulse sensor. The pulse sensor employs a VBW = 50MHz so this method was only used for signals whose DTS bandwidth was less than or equal to 50MHz.

Method AVGPM-G (Measurement using a gated RF average-reading power meter)

Measurements may be performed using a wideband gated RF power meter provided that the gate parameters are adjusted such that the power is measured only when the EUT is transmitting at its maximum power control level. Since this measurement is made only during the ON time of the transmitter, no duty cycle correction is required.

5.3.4. Test Setup

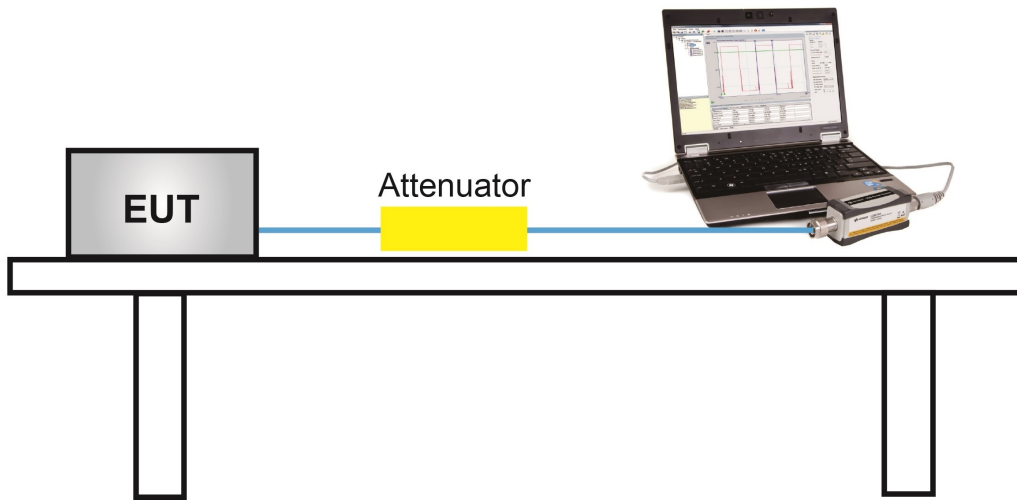

5.3.5. Test Result

Test Site	WZ-TR3	Test Engineer	Luis Yang
Test Date	2021/09/02		

Test Result of Peak Output Power

Test Mode	Channel No.	Frequency (MHz)	Peak Power (dBm)	Limit (dBm)	Max EIRP (dBm)	EIRP Limit (dBm)	Result
GFSK	01	2410	10.70	≤ 30.00	13.70	≤ 36.00	Pass
GFSK	29	2438	10.82	≤ 30.00	13.82	≤ 36.00	Pass
GFSK	56	2465	10.91	≤ 30.00	13.91	≤ 36.00	Pass
GFSK	57	2480	-10.62	≤ 30.00	-7.62	≤ 36.00	Pass

Note: Max EIRP (dBm) = Peak Power (dBm) + Antenna Gain (dBi).

Test Result of Average Output Power (Reporting Only)

Test Mode	Channel No.	Frequency (MHz)	Average Power (dBm)	Limit (dBm)	Max EIRP (dBm)	EIRP Limit (dBm)	Result
GFSK	01	2410	10.57	≤ 30.00	13.57	≤ 36.00	Pass
GFSK	29	2438	10.73	≤ 30.00	13.73	≤ 36.00	Pass
GFSK	56	2465	10.81	≤ 30.00	13.81	≤ 36.00	Pass
GFSK	57	2480	-18.10	≤ 30.00	-15.10	≤ 36.00	Pass

Note: Max EIRP (dBm) = Average Power (dBm) + Antenna Gain (dBi).

5.4. Power Spectral Density Measurement

5.4.1. Test Limit

The maximum permissible power spectral density is 8dBm in any 3 kHz band.

The same method of determining the conducted output power shall be used to determine the power spectral density.

5.4.2. Test Procedure Used

ANSI C63.10-2013 - Section 11.10.2.

5.4.3. Test Setting

1. Analyzer was set to the center frequency of the DTS channel under investigation
2. Span = 1.5 times the DTS channel bandwidth
3. RBW = 3kHz
4. VBW = 10kHz
5. Detector = peak
6. Sweep time = auto couple
7. Trace mode = max hold
8. Trace was allowed to stabilize

5.4.4. Test Setup

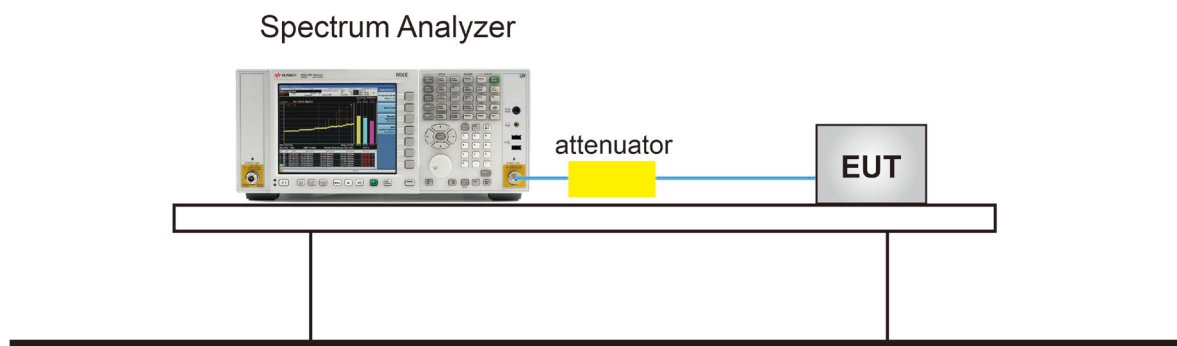

5.4.5. Test Result

Test Site	WZ-TR3	Test Engineer	Luis Yang
Test Date	2021/10/26		

Test Mode	Channel No.	Frequency (MHz)	PSD Result (dBm / 3kHz)	Limit (dBm / 3kHz)	Result
GFSK	01	2410	1.724	≤ 8.00	Pass
GFSK	29	2438	1.904	≤ 8.00	Pass
GFSK	56	2465	2.072	≤ 8.00	Pass
GFSK	57	2480	-27.834	≤ 8.00	Pass

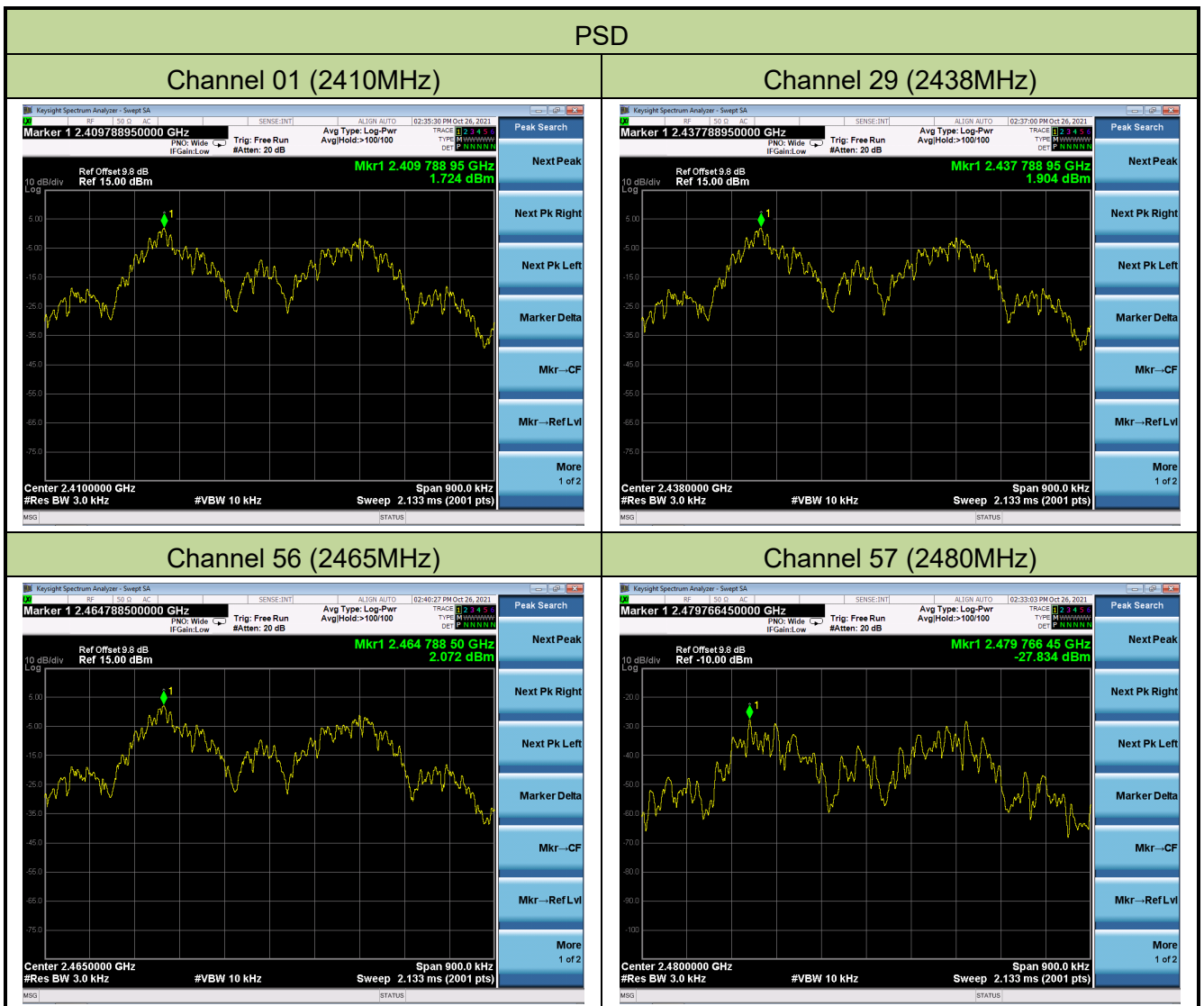

5.5. Conducted Band Edge and Out-of-Band Emissions

5.5.1. Test Limit

The limit for out-of-band spurious emissions at the band edge is 20dB below the fundamental emission level, as determined from the in-band power measurement of the DTS channel performed in a 100 kHz bandwidth per the PSD procedure.

5.5.2. Test Procedure Used

ANSI C63.10-2013 - Section 11.11.2 & 11.11.3.

5.5.3. Test Setting

Reference level measurement

1. Set instrument center frequency to DTS channel center frequency
2. Set the span to ≥ 1.5 times the DTS bandwidth
3. Set the RBW = 100 kHz
4. Set the VBW $\geq 3 \times$ RBW
5. Detector = peak
6. Sweep time = auto couple
7. Trace mode = max hold
8. Allow trace to fully stabilize

Emission level measurement

1. Set the center frequency and span to encompass frequency range to be measured
2. RBW = 100KHz
3. VBW = 300KHz
4. Detector = Peak
5. Trace mode = max hold
6. Sweep time = auto couple
7. The trace was allowed to stabilize

5.5.4. Test Setup

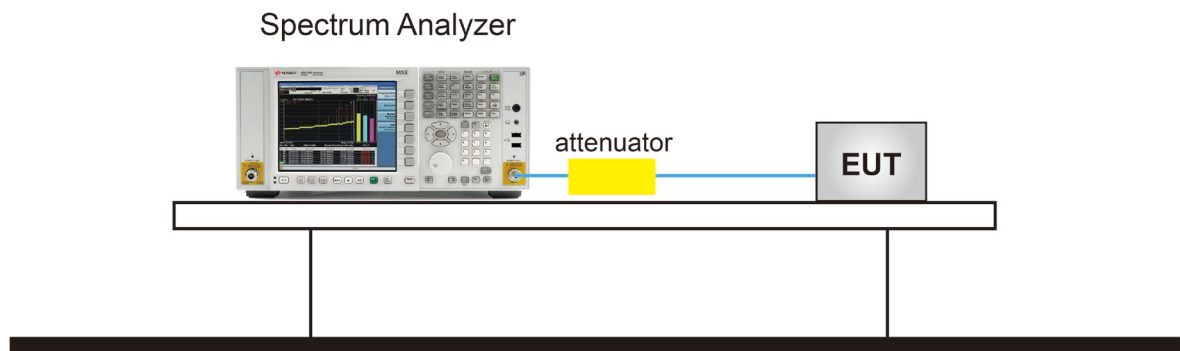

5.5.5. Test Result

Test Site	WZ-TR3	Test Engineer	Luis Yang
Test Date	2021/10/26		

Test Mode	Channel No.	Frequency (MHz)	Limit (dBc)	Result
GFSK	01	2410	20	Pass
GFSK	29	2438	20	Pass
GFSK	56	2465	20	Pass
GFSK	57	2480	20	Pass

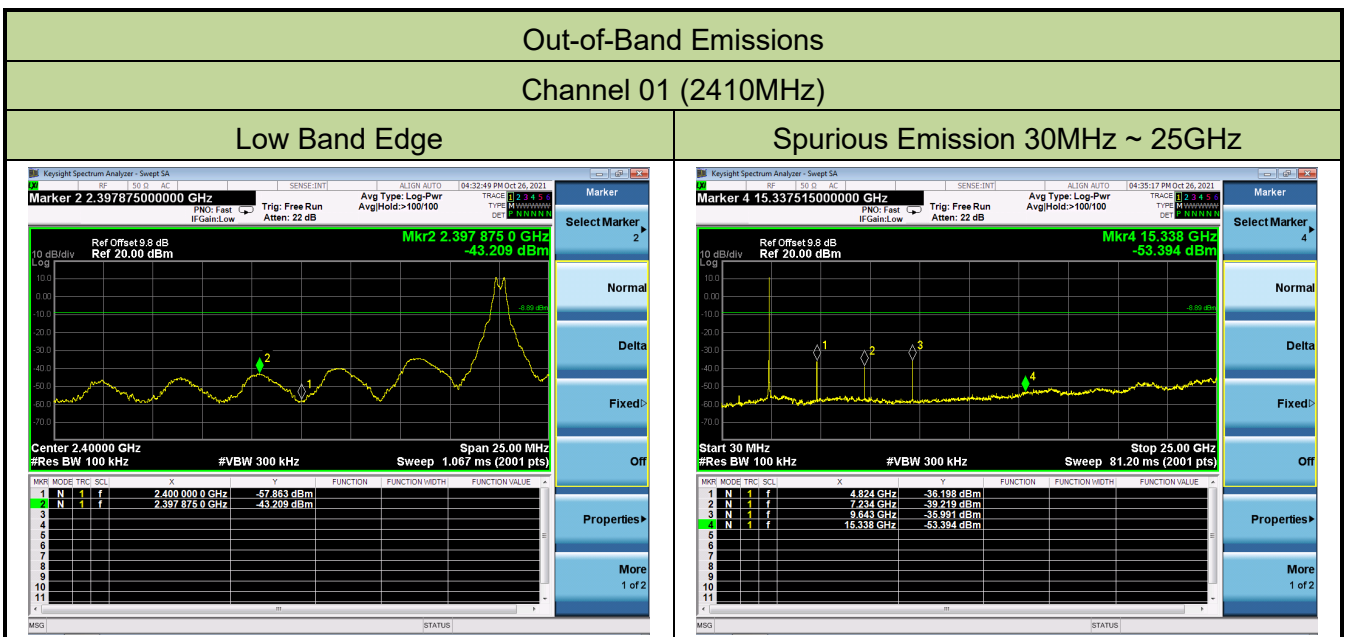

Channel 29 (2438MHz)

Spurious Emission 30MHz ~ 25GHz

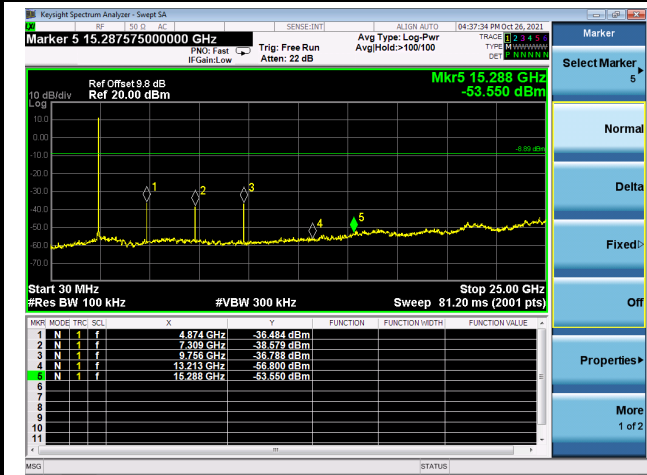

Channel 56 (2465MHz)

100kHz PSD Reference Level

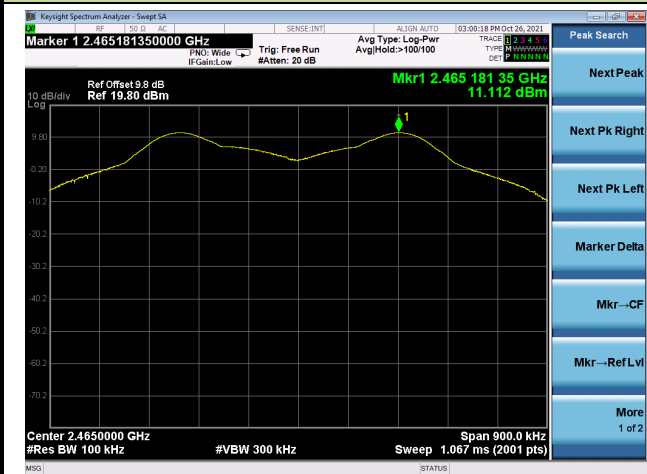

High Band Edge

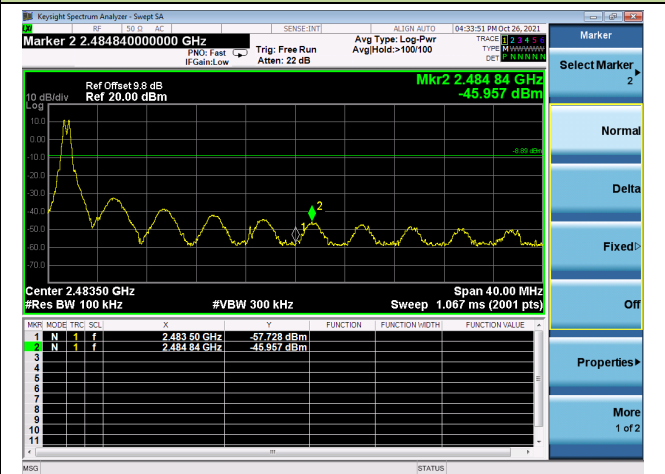

Spurious Emission 30MHz ~ 25GHz

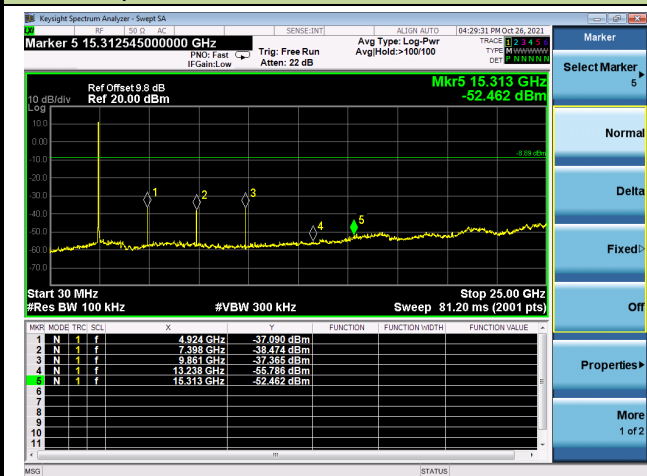

Channel 57 (2480MHz)

100kHz PSD Reference Level



High Band Edge

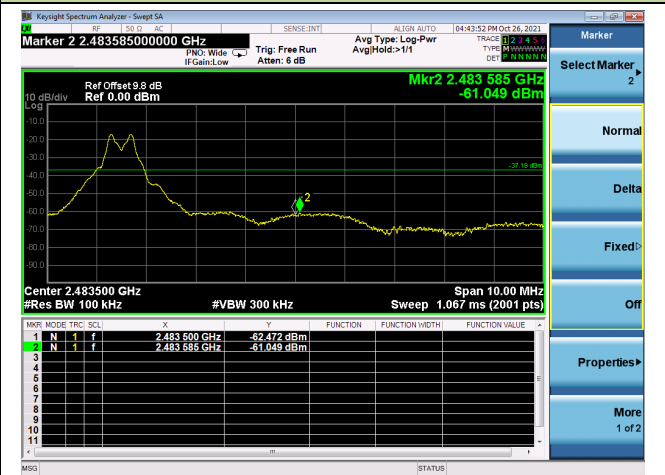

Spurious Emission 30MHz ~ 25GHz

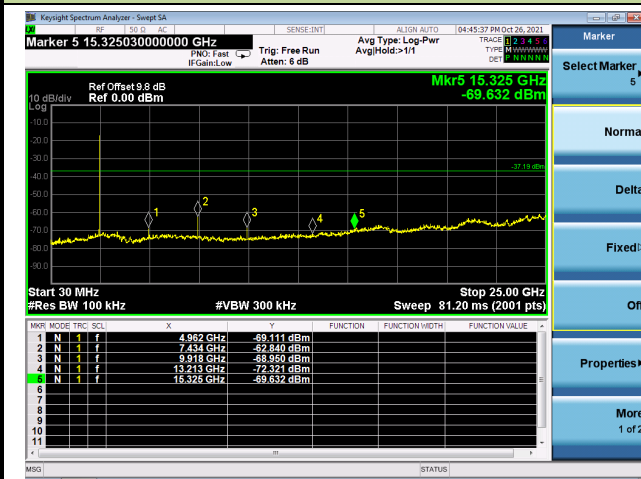

5.6. Radiated Spurious Emission Measurement

5.6.1. Test Limit

All out of band emissions appearing in a restricted band as specified in Section 15.205 of the Title 47CFR must not exceed the limits shown in Table per Section 15.209.

FCC Part 15 Subpart C Paragraph 15.209 & RSS-Gen Section 8.9		
Frequency [MHz]	Field Strength [uV/m]	Measured Distance [Meters]
0.009 - 0.490	2400/F (kHz)	300
0.490 - 1.705	24000/F (kHz)	30
1.705 - 30	30	30
30 - 88	100	3
88 - 216	150	3
216 - 960	200	3
Above 960	500	3

5.6.2. Test Procedure Used

ANSI C63.10 Section 6.3 (General Requirements)

ANSI C63.10 Section 6.4 (Standard test method below 30MHz)

ANSI C63.10 Section 6.5 (Standard test method above 30MHz to 1GHz)

ANSI C63.10 Section 6.6 (Standard test method above 1GHz)

5.6.3. Test Setting

Table 1 - RBW as a function of frequency

Frequency	RBW
9 ~ 150 kHz	200 ~ 300 Hz
0.15 ~ 30 MHz	9 ~ 10 kHz
30 ~ 1000 MHz	100 ~ 120 kHz
> 1000 MHz	1 MHz

Quasi-Peak Measurements below 1GHz

1. Analyzer center frequency was set to the frequency of the radiated spurious emission of interest
2. Span was set greater than 1MHz
3. RBW = as specified in Table 1
4. Detector = CISPR quasi-peak
5. Sweep time = auto couple
6. Trace was allowed to stabilize

Peak Measurements above 1GHz

1. Analyzer center frequency was set to the frequency of the radiated spurious emission of interest
2. RBW = 1MHz
3. VBW = 3MHz
4. Detector = peak
5. Sweep time = auto couple
6. Trace mode = max hold
7. Trace was allowed to stabilize

Average Measurements above 1GHz (Method VB)

1. Analyzer center frequency was set to the frequency of the radiated spurious emission of interest
2. RBW = 1MHz
3. VBW; If the EUT is configured to transmit with duty cycle $\geq 98\%$, set VBW = 10 Hz.
If the EUT duty cycle is $< 98\%$, set VBW $\geq 1/T$. T is the minimum transmission duration.
4. Detector = Peak
5. Sweep time = auto
6. Trace mode = max hold
7. Trace was allowed to stabilize

5.6.4. Test Setup

Below 1GHz Test Setup:

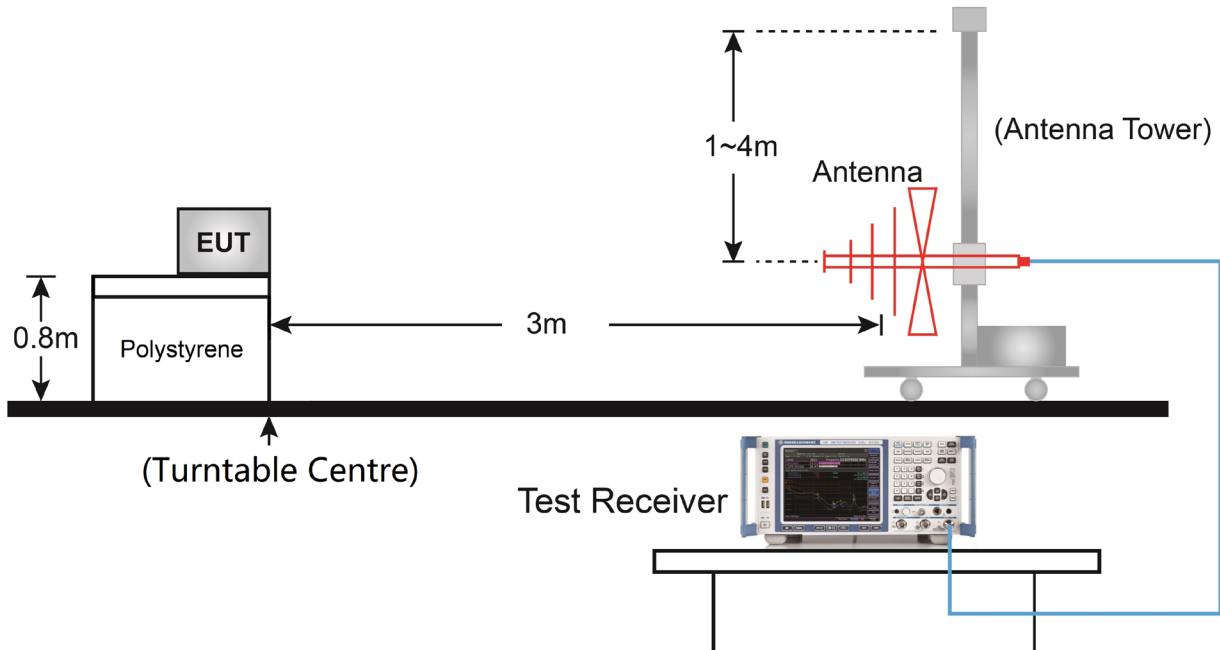

Above 1GHz Test Setup:

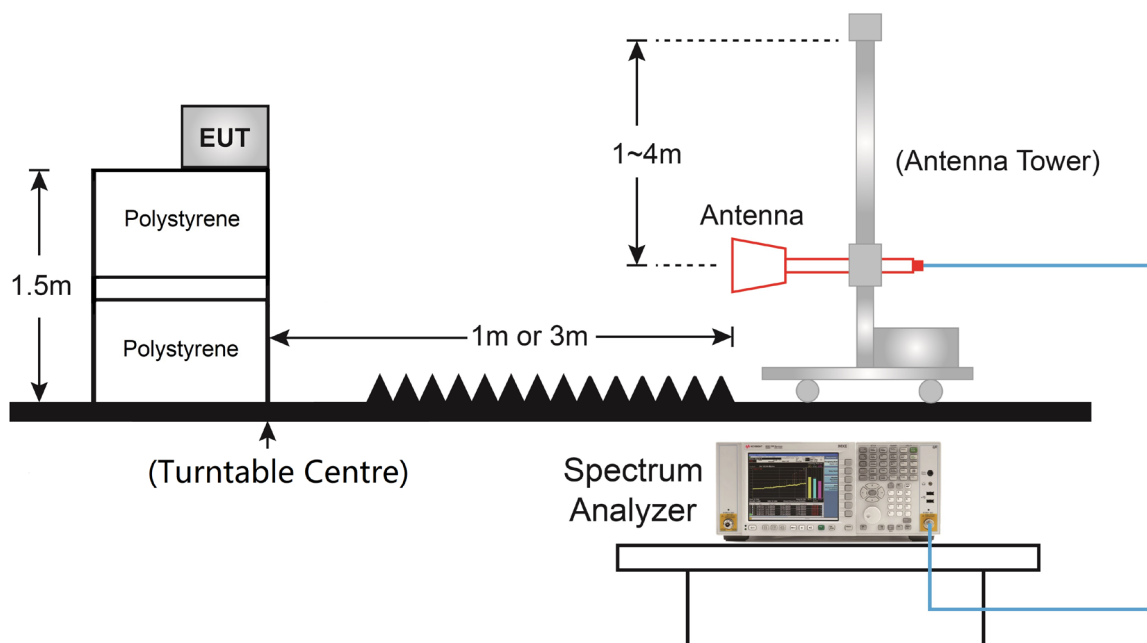

5.6.5. Test Result

Test Site	WZ-AC2	Test Engineer	Bob Zhang
Test Date	2021/09/02	Test Channel	01
Test Mode	GFSK		
Note	1. Average measurement was not performed if peak level lower than average limit. 2. Other frequency was 20dB below limit line within 1-18GHz, there is not show in the report.		

Frequency (MHz)	Reading Level (dB μ V)	Factor (dB/m)	Duty Cycle Factor (dB)	Measure Level (dB μ V/m)	Limit (dB μ V/m)	Margin (dB)	Detector	Polarization
4816.5	58.5	4.4	N/A	62.9	74.0	-11.1	Peak	Horizontal
4816.5	58.5	4.4	-40.0	22.9	54.0	-31.1	Average	Horizontal
7536.5	33.2	12.1	N/A	45.3	74.0	-28.7	Peak	Horizontal
8225.0	35.9	12.0	N/A	47.9	74.0	-26.1	Peak	Horizontal
4816.5	60.0	4.4	N/A	64.4	74.0	-9.6	Peak	Vertical
4816.5	60.0	4.4	-40.0	24.4	54.0	-29.6	Average	Vertical
7468.5	33.2	12.1	N/A	45.3	74.0	-28.7	Peak	Vertical
8352.5	35.5	12.1	N/A	47.6	74.0	-26.4	Peak	Vertical

Note: Measure Level (dB μ V/m) = Reading Level (dB μ V) + Factor (dB/m)

Factor (dB/m) = Cable Loss (dB) + Antenna Factor (dB/m) - Pre_Amplifier Gain (dB)

Average Measure Level (dB μ V/m) = Peak Measure Level (dB μ V/m) + Duty Cycle Factor (dB)

Test Site	WZ-AC2	Test Engineer	Bob Zhang
Test Date	2021/09/02	Test Channel	29
Test Mode	GFSK		
Note	1. Average measurement was not performed if peak level lower than average limit. 2. Other frequency was 20dB below limit line within 1-18GHz, there is not show in the report.		

Frequency (MHz)	Reading Level (dB μ V)	Factor (dB/m)	Duty Cycle Factor (dB)	Measure Level (dB μ V/m)	Limit (dB μ V/m)	Margin (dB)	Detector	Polarization
4876.0	58.1	4.4	N/A	62.5	74.0	-11.5	Peak	Horizontal
4876.0	58.1	4.4	-40.0	22.5	54.0	-31.5	Average	Horizontal
7315.5	41.3	12.1	N/A	53.4	74.0	-20.6	Peak	Horizontal
8352.5	33.0	12.1	N/A	45.1	74.0	-28.9	Peak	Horizontal
4876.0	57.7	4.4	N/A	62.1	74.0	-11.9	Peak	Vertical
4876.0	57.7	4.4	-40.0	22.1	54.0	-31.9	Average	Vertical
7315.5	46.6	12.1	N/A	58.7	74.0	-15.3	Peak	Vertical
7315.5	46.6	12.1	-40.0	18.7	54.0	-35.3	Average	Vertical
8276.0	33.7	11.9	N/A	45.6	74.0	-28.4	Peak	Vertical

Note: Measure Level (dB μ V/m) = Reading Level (dB μ V) + Factor (dB/m)

Factor (dB/m) = Cable Loss (dB) + Antenna Factor (dB/m) - Pre_Amplifier Gain (dB)

Average Measure Level (dB μ V/m) = Peak Measure Level (dB μ V/m) + Duty Cycle Factor (dB)

Test Site	WZ-AC2	Test Engineer	Bob Zhang
Test Date	2021/09/02	Test Channel	56
Test Mode	GFSK		
Note	1. Average measurement was not performed if peak level lower than average limit. 2. Other frequency was 20dB below limit line within 1-18GHz, there is not show in the report.		

Frequency (MHz)	Reading Level (dB μ V)	Factor (dB/m)	Duty Cycle Factor (dB)	Measure Level (dB μ V/m)	Limit (dB μ V/m)	Margin (dB)	Detector	Polarization
4927.0	57.4	4.6	N/A	62.0	74.0	-12.0	Peak	Horizontal
4927.0	57.4	4.6	-40.0	22.0	54.0	-32.0	Average	Horizontal
7392.0	40.5	12.1	N/A	52.6	74.0	-21.4	Peak	Horizontal
8276.0	33.8	11.9	N/A	45.7	74.0	-28.3	Peak	Horizontal
4927.0	58.7	4.6	N/A	63.3	74.0	-10.7	Peak	Vertical
4927.0	58.7	4.6	-40.0	23.3	54.0	-30.7	Average	Vertical
7392.0	44.3	12.1	N/A	56.4	74.0	-17.6	Peak	Vertical
8199.5	33.2	12.3	N/A	45.5	74.0	-28.5	Peak	Vertical

Note: Measure Level (dB μ V/m) = Reading Level (dB μ V) + Factor (dB/m)

Factor (dB/m) = Cable Loss (dB) + Antenna Factor (dB/m) - Pre_Amplifier Gain (dB)

Average Measure Level (dB μ V/m) = Peak Measure Level (dB μ V/m) + Duty Cycle Factor (dB)

Test Site	WZ-AC2	Test Engineer	Bob Zhang
Test Date	2021/09/02	Test Channel	57
Test Mode	GFSK		
Note	1. Average measurement was not performed if peak level lower than average limit. 2. Other frequency was 20dB below limit line within 1-18GHz, there is not show in the report.		

Frequency (MHz)	Reading Level (dB μ V)	Factor (dB/m)	Duty Cycle Factor (dB)	Measure Level (dB μ V/m)	Limit (dB μ V/m)	Margin (dB)	Detector	Polarization
4961.0	39.5	4.5	N/A	44.0	74.0	-30.0	Peak	Horizontal
7604.5	32.8	12.0	N/A	44.8	74.0	-29.2	Peak	Horizontal
8242.0	33.2	12.2	N/A	45.4	74.0	-28.6	Peak	Horizontal
4961.0	46.1	4.5	N/A	50.6	74.0	-23.4	Peak	Vertical
7443.0	35.5	12.2	N/A	47.7	74.0	-26.3	Peak	Vertical
8242.0	34.3	12.2	N/A	46.5	74.0	-27.5	Peak	Vertical

Note: Measure Level (dB μ V/m) = Reading Level (dB μ V) + Factor (dB/m)

Factor (dB/m) = Cable Loss (dB) + Antenna Factor (dB/m) - Pre_Amplifier Gain (dB)

The Worst Case of Radiated Emission below 1GHz:

Site: WZ-AC2	Time: 2021/09/04 - 00:26
Limit: FCC_Part15.209_RSE(3m)	Engineer: Lucas Wang
Probe: WZ-AC2_VULB9162_0.03-7GHz	Polarity: Horizontal
EUT: SLT2 2CH TX	Power: By Battery
Test Mode: Transmit at channel 29 (2438MHz).	

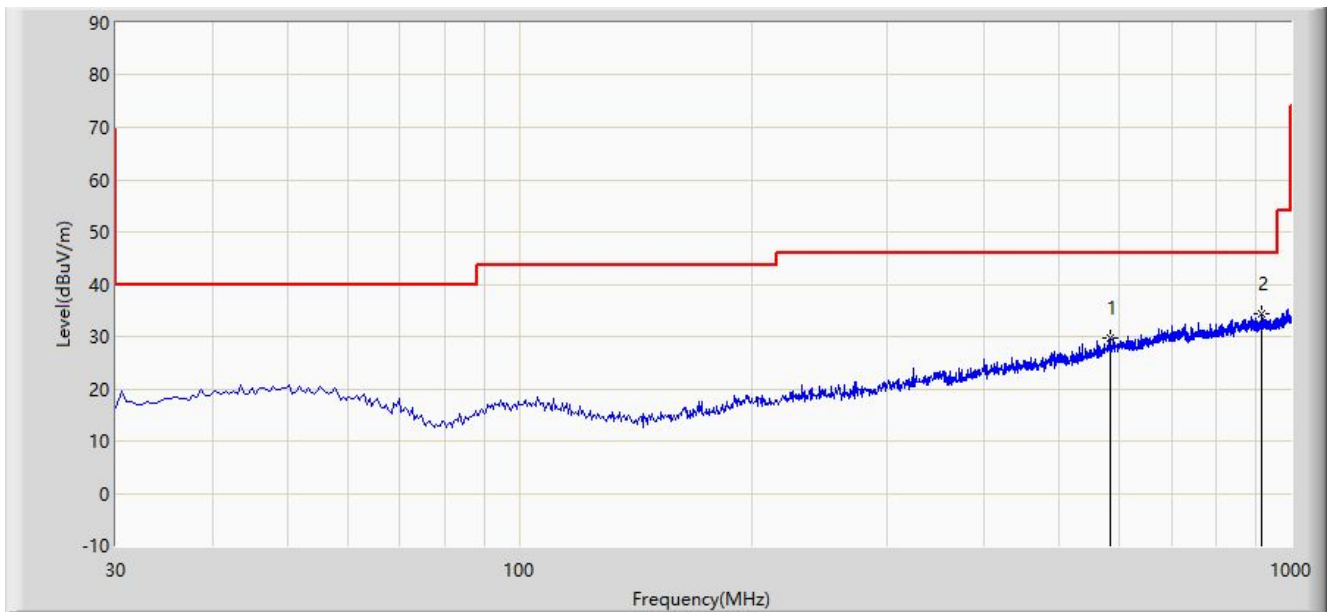

No	Flag	Mark	Frequency (MHz)	Measure Level (dBμV/m)	Reading Level (dBμV)	Margin (dB)	Limit (dBμV/m)	Factor (dB/m)	Type
1			583.870	29.829	2.743	-16.171	46.000	27.086	PK
2		*	916.580	34.305	2.734	-11.695	46.000	31.571	PK

Note 1: Measure Level (dBμV/m) = Reading Level (dBμV) + Factor (dB/m)

Factor (dB/m) = Cable Loss (dB) + Antenna Factor (dB/m)

Note 2: The amplitude of radiated emissions (9kHz ~ 30MHz, 18GHz to 25GHz) is that proximity to ambient noise, which also are attenuated more than 20 dB below the permissible value. Therefore, the data is not presented in the report.

Note 3: QP measurement was not performed when the peak level lower than QP limit.

Site: WZ-AC2	Time: 2021/09/04 - 00:31
Limit: FCC_Part15.209_RSE(3m)	Engineer: Lucas Wang
Probe: WZ-AC2_VULB9162_0.03-7GHz	Polarity: Vertical
EUT: SLT2 2CH TX	Power: By Battery
Test Mode: Transmit at channel 29 (2438MHz).	

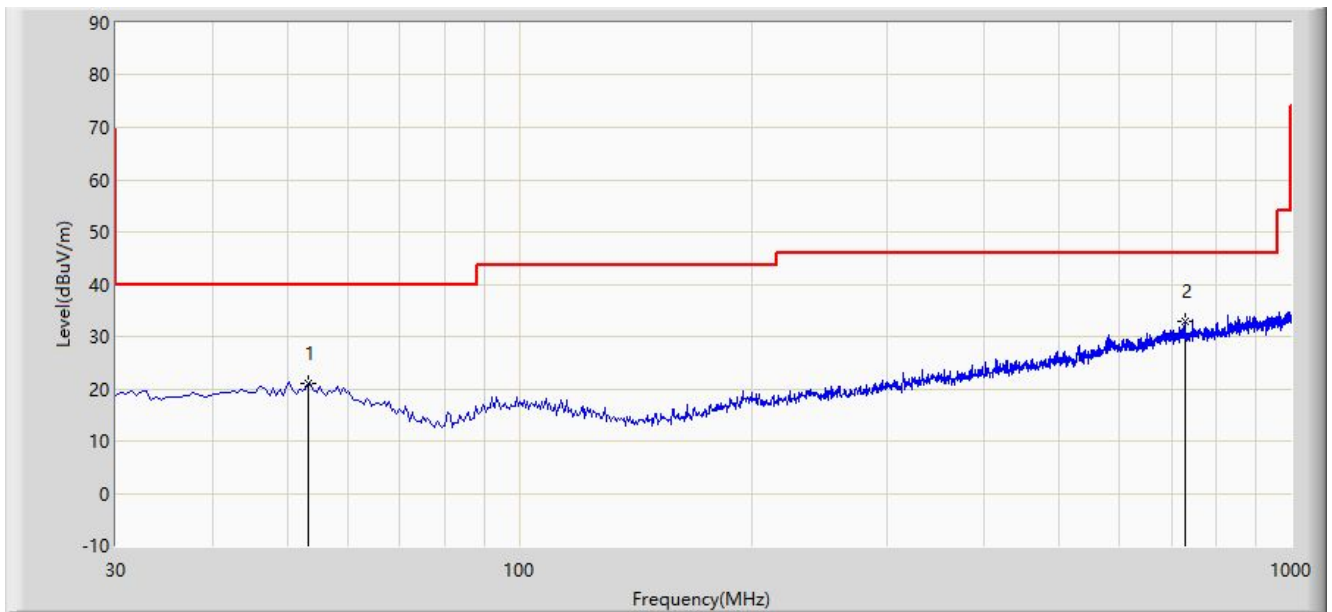

No	Flag	Mark	Frequency (MHz)	Measure Level (dBμV/m)	Reading Level (dBμV)	Margin (dB)	Limit (dBμV/m)	Factor (dB/m)	Type
1			53.280	20.983	0.644	-19.017	40.000	20.339	PK
2		*	729.855	33.021	3.886	-12.979	46.000	29.135	PK

Note 1: Measure Level (dBμV/m) = Reading Level (dBμV) + Factor (dB/m)

Factor (dB/m) = Cable Loss (dB) + Antenna Factor (dB/m)

Note 2: The amplitude of radiated emissions (9kHz ~ 30MHz, 18GHz to 25GHz) is that proximity to ambient noise, which also are attenuated more than 20 dB below the permissible value. Therefore, the data is not presented in the report.

Note 3: QP measurement was not performed when the peak level lower than QP limit.

5.7. Radiated Restricted Band Edge Measurement

5.7.1. Test Limit

For 15.205 requirement:

Radiated emissions which fall in the restricted bands, as defined in Section 15.205(a) of FCC part 15, must also comply with the radiated emission limits specified in Section 15.209(a).

Frequency (MHz)	Frequency (MHz)	Frequency (MHz)	Frequency (GHz)
0.090 - 0.110	16.42 - 16.423	399.9 - 410	4.5 - 5.15
¹ 0.495 - 0.505	16.69475 - 16.69525	608 - 614	5.35 - 5.46
2.1735 - 2.1905	16.80425 - 16.80475	960 - 1240	7.25 - 7.75
4.125 - 4.128	25.5 - 25.67	1300 - 1427	8.025 - 8.5
4.17725 - 4.17775	37.5 - 38.25	1435 - 1626.5	9.0 - 9.2
4.20725 - 4.20775	73 - 74.6	1645.5 - 1646.5	9.3 - 9.5
6.215 - 6.218	74.8 - 75.2	1660 - 1710	10.6 - 12.7
6.26775 - 6.26825	108 - 121.94	1718.8 - 1722.2	13.25 - 13.4
6.31175 - 6.31225	123 - 138	2200 - 2300	14.47 - 14.5
8.291 - 8.294	149.9 - 150.05	2310 - 2390	15.35 - 16.2
8.362 - 8.366	156.52475 - 156.52525	2483.5 - 2500	17.7 - 21.4
8.37625 - 8.38675	156.7 - 156.9	2690 - 2900	22.01 - 23.12
8.41425 - 8.41475	162.0125 - 167.17	3260 - 3267	23.6 - 24.0
12.29 - 12.293	167.72 - 173.2	3332 - 3339	31.2 - 31.8
12.51975 - 12.52025	240 - 285	3345.8 - 3358	36.43 - 36.5
12.57675 - 12.57725	322 - 335.4	3600 - 4400	(²)
13.36 - 13.41	--	--	--

All out of band emissions appearing in a restricted band as specified in Section 15.205 of the Title 47CFR must not exceed the limits shown in Table per Section 15.209.

FCC Part 15 Subpart C Paragraph 15.209 Limits		
Frequency [MHz]	Field Strength [uV/m]	Measured Distance [Meters]
0.009 - 0.490	2400/F (kHz)	300
0.490 - 1.705	24000/F (kHz)	30
1.705 - 30	30	30
30 - 88	100	3
88 - 216	150	3
216 - 960	200	3
Above 960	500	3

For RSS-Gen Section 8.10 Requirement

Radiated emissions which fall in the restricted bands, as defined in Section 8.10 of RSS-Gen, must also comply with the radiated emission limits specified in Section 8.9.

Frequency (MHz)	Frequency (MHz)	Frequency (GHz)
0.090 - 0.110	149.9 - 150.05	9.0 - 9.2
0.495 - 0.505	156.52475 - 156.525225	9.3 - 9.5
2.1735 - 2.1905	156.7 - 156.9	10.6 - 12.7
3.020 - 3.026	162.0125 - 167.17	13.25 - 13.4
4.125 - 4.128	167.72 - 173.2	14.47 - 14.5
4.17725 - 4.17775	240 - 285	15.35 - 16.2
4.20725 - 4.20775	322 - 335.4	17.7 - 21.4
5.677 - 5.683	399.9 - 410	22.01 - 23.12
6.215 - 6.218	608 - 614	23.6 - 24.0
6.26775 - 6.26825	960 - 1427	31.2 - 31.8
6.31175 - 6.31225	1435 - 1626.5	36.43 - 36.5
8.291 - 8.294	1645.5 - 1646.5	Above 38.6
8.362 - 8.366	1660 - 1710	--
8.37625 - 8.38675	1718.8 - 1722.2	
8.41425 - 8.41475	2200 - 2300	
12.29 - 12.293	2310 - 2390	
12.51975 - 12.52025	2483.5 - 2500	
12.57675 - 12.57725	2655 - 2900	
13.36 - 13.41	3260 - 3267	
16.42 - 16.423	3332 - 3339	
16.69475 - 16.69525	3345.8 - 3358	
16.80425 - 16.80475	3500 - 4400	
25.5 - 25.67	4500 - 5150	
37.5 - 38.25	5350 - 5460	
73 - 74.6	7250 - 7750	
74.8 - 75.2	8025 - 8500	
108 - 138	--	

All out of band emissions appearing in a restricted band as specified in Section 8.10 of the RSS-Gen must not exceed the limits shown in Table per Section 8.9.

RSS-Gen Section 8.9			
Frequency [MHz]	Magnetic field strength (H-Field) [uA/m]	Field Strength [uV/m]	Measured Distance [Meters]
0.009 - 0.490	6.37/F(F in kHz)	--	300
0.490 - 1.705	63.7/F(F in kHz)	--	30
1.705 - 30	0.08	--	30
30 - 88	--	100	3
88 - 216	--	150	3
216 - 960	--	200	3
Above 960	--	500	3

5.7.2. Test Procedure Used

ANSI C63.10 Section 6.3 (General Requirements)

ANSI C63.10 Section 6.6 (Standard test method above 1GHz)

5.7.3. Test Setting

Peak Field Strength Measurements

1. Analyzer center frequency was set to the frequency of the radiated spurious emission of interest
2. RBW = 1MHz
3. VBW = 3MHz
4. Detector = peak
5. Sweep time = auto couple
6. Trace mode = max hold
7. Trace was allowed to stabilize

Average Measurements above 1GHz (Method VB)

1. Analyzer center frequency was set to the frequency of the radiated spurious emission of interest
2. RBW = 1MHz
3. VBW; If the EUT is configured to transmit with duty cycle $\geq 98\%$, set VBW = 10 Hz.
If the EUT duty cycle is $< 98\%$, set VBW $\geq 1/T$. T is the minimum transmission duration.
4. Detector = Peak
5. Sweep time = auto
6. Trace mode = max hold
7. Trace was allowed to stabilize

5.7.4. Test Setup

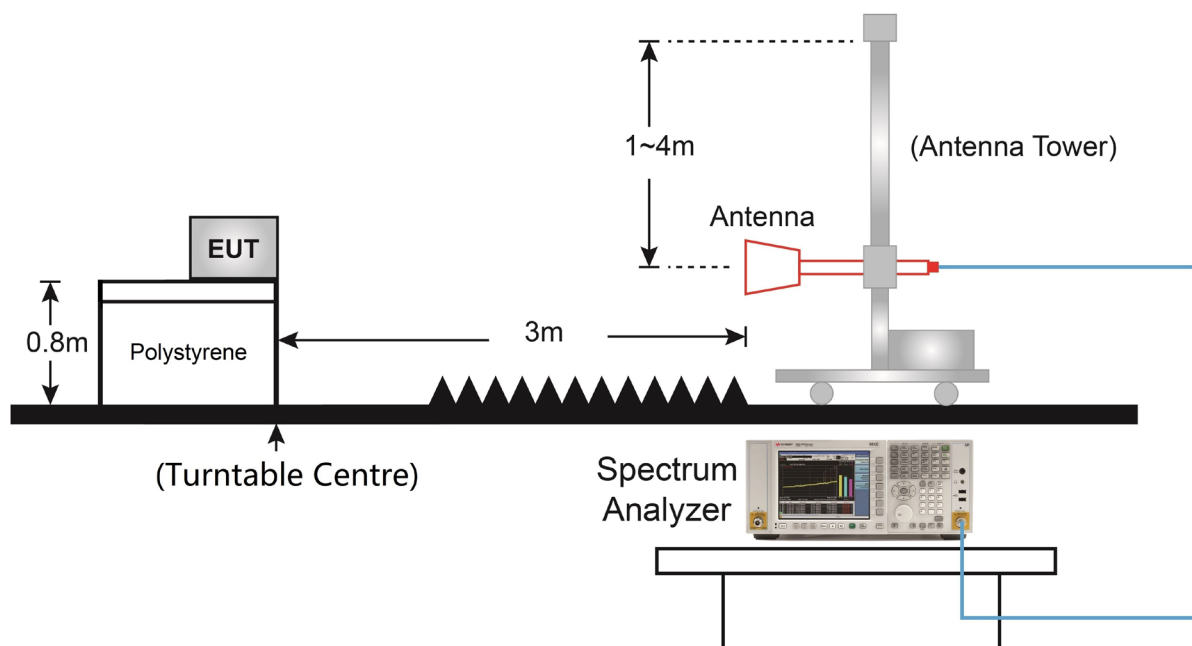

5.7.5. Test Result

Site: WZ-AC1	Time: 2021/10/26 - 18:55
Limit: FCC_Part15_Band Edge(3m)	Engineer: Lucas Wang
Probe: WZ-AC1_BBHA9120D_1-18GHz	Polarity: Horizontal
EUT: SLT2 2CH TX	Power: By Battery
Test Mode: Transmit at channel 01 (2410MHz).	

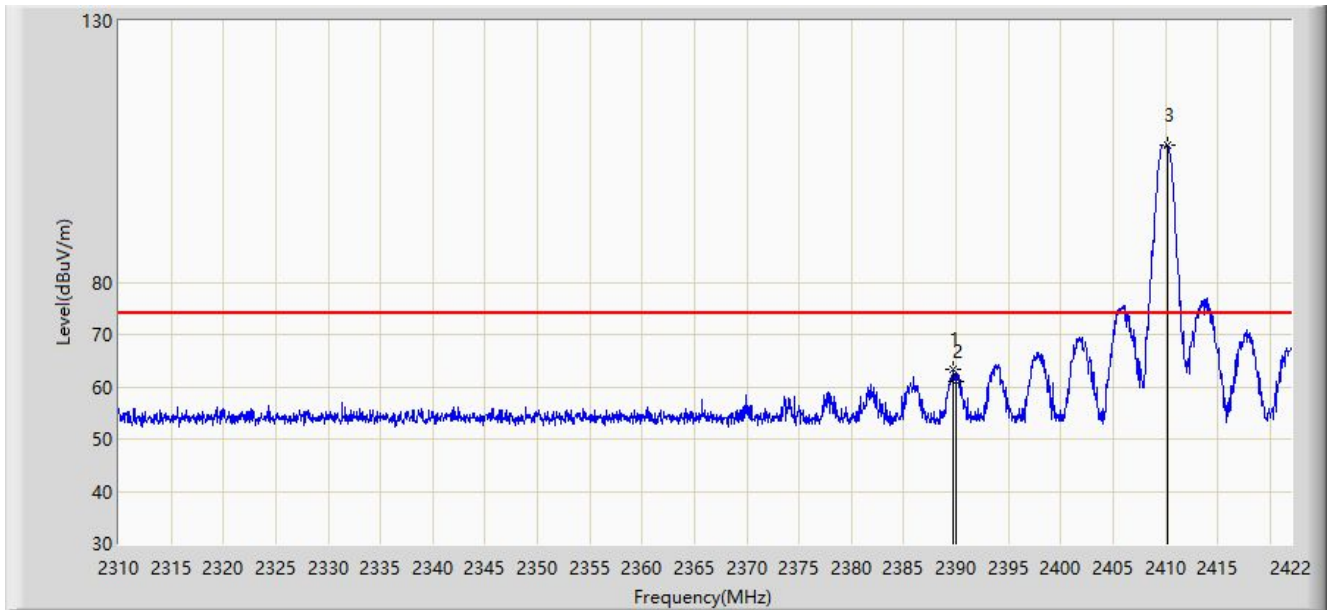

No	Flag	Mark	Frequency (MHz)	Measure Level (dBμV/m)	Reading Level (dBμV)	Duty Cycle Factor (dB)	Margin (dB)	Limit (dBμV/m)	Factor (dB/m)	Type
1			2389.688	63.259	32.444	N/A	-10.741	74.000	30.815	PK
			2389.688	23.259	-7.556	-40.000	-30.741	54.000	30.815	AV
2			2390.000	61.108	30.292	N/A	-12.892	74.000	30.816	PK
			2390.000	21.108	-9.708	-40.000	-32.892	54.000	30.816	AV
3		*	2410.184	106.182	75.347	N/A	N/A	N/A	30.835	PK

Note: Peak Measure Level (dBμV/m) = Reading Level (dBμV) + Factor (dB)

Average Measure Level (dBμV/m) = Reading Level (dBμV) + Factor (dB) + Duty Cycle Factor (dB)

Factor (dB/m) = Cable Loss (dB) + Antenna Factor (dB/m)

Site: WZ-AC1	Time: 2021/10/26 - 19:01
Limit: FCC_Part15_Band Edge(3m)	Engineer: Lucas Wang
Probe: WZ-AC1_BBHA9120D_1-18GHz	Polarity: Vertical
EUT: SLT2 2CH TX	Power: By Battery
Test Mode: Transmit at channel 01 (2410MHz).	

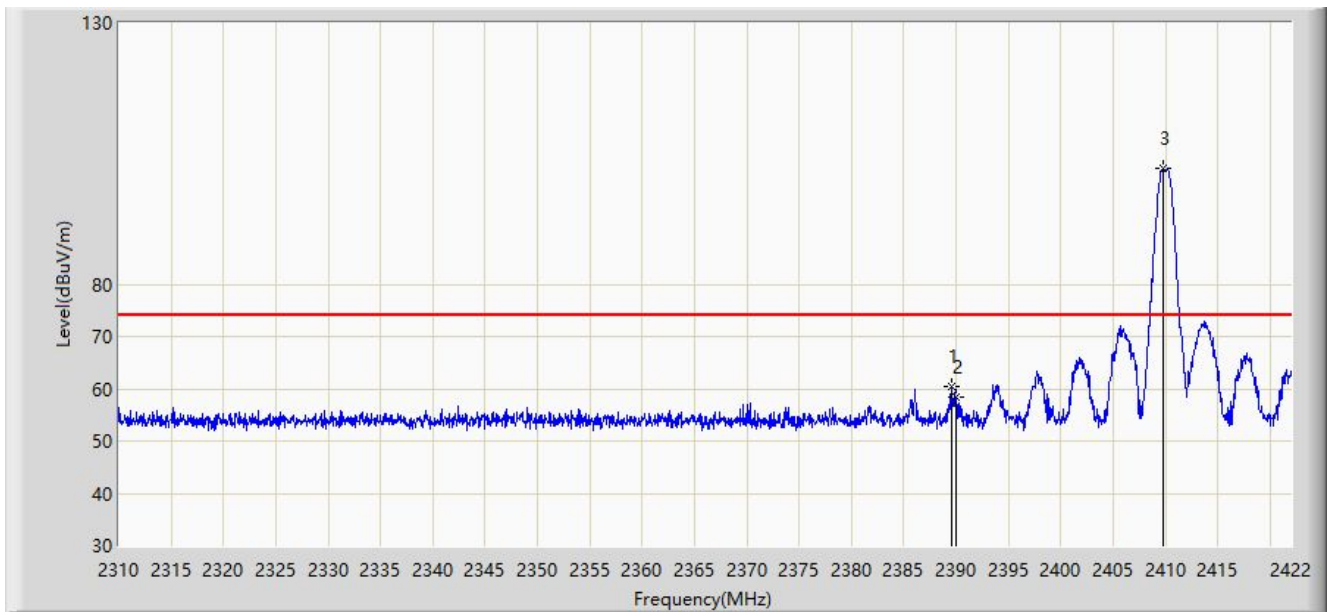

No	Flag	Mark	Frequency (MHz)	Measure Level (dBμV/m)	Reading Level (dBμV)	Duty Cycle Factor (dB)	Margin (dB)	Limit (dBμV/m)	Factor (dB/m)	Type
1			2389.520	60.484	29.669	N/A	-13.516	74.000	30.815	PK
			2389.520	20.484	-10.331	-40.000	-33.516	54.000	30.815	AV
2			2390.000	58.278	27.462	N/A	-15.722	74.000	30.816	PK
			2390.000	18.278	-12.538	-40.000	-35.722	54.000	30.816	AV
3		*	2409.736	102.089	71.253	N/A	N/A	N/A	30.835	PK

Note: Peak Measure Level (dBμV/m) = Reading Level (dBμV) + Factor (dB)

Average Measure Level (dBμV/m) = Reading Level (dBμV) + Factor (dB) + Duty Cycle Factor (dB)

Factor (dB/m) = Cable Loss (dB) + Antenna Factor (dB/m)

Site: WZ-AC1	Time: 2021/10/26 - 18:48
Limit: FCC_Part15_Band Edge(3m)	Engineer: Lucas Wang
Probe: WZ-AC1_BBHA9120D_1-18GHz	Polarity: Horizontal
EUT: SLT2 2CH TX	Power: By Battery
Test Mode: Transmit at channel 56 (2465MHz).	

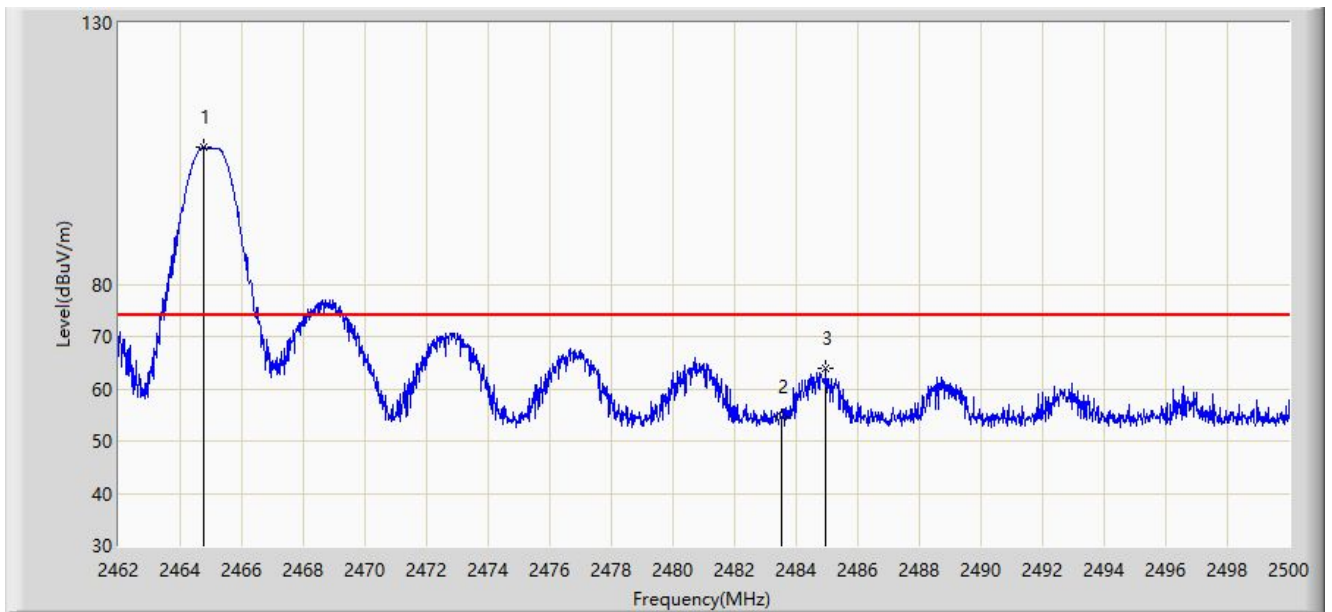

No	Flag	Mark	Frequency (MHz)	Measure Level (dBμV/m)	Reading Level (dBμV)	Duty Cycle Factor (dB)	Margin (dB)	Limit (dBμV/m)	Factor (dB/m)	Type
1		*	2464.774	106.165	75.203	N/A	N/A	N/A	30.963	PK
2			2483.500	54.661	23.640	N/A	-19.339	74.000	31.021	PK
			2483.500	14.661	-16.360	-40.000	-39.339	54.000	31.021	AV
3			2484.952	63.903	32.876	N/A	-10.097	74.000	31.027	PK
			2484.952	23.903	-7.124	-40.000	-30.097	54.000	31.027	AV

Note: Peak Measure Level (dBμV/m) = Reading Level (dBμV) + Factor (dB)

Average Measure Level (dBμV/m) = Reading Level (dBμV) + Factor (dB) + Duty Cycle Factor (dB)

Factor (dB/m) = Cable Loss (dB) + Antenna Factor (dB/m)

Site: WZ-AC1	Time: 2021/10/26 - 18:52
Limit: FCC_Part15_Band Edge(3m)	Engineer: Lucas Wang
Probe: WZ-AC1_BBHA9120D_1-18GHz	Polarity: Vertical
EUT: SLT2 2CH TX	Power: By Battery
Test Mode: Transmit at channel 56 (2465MHz).	

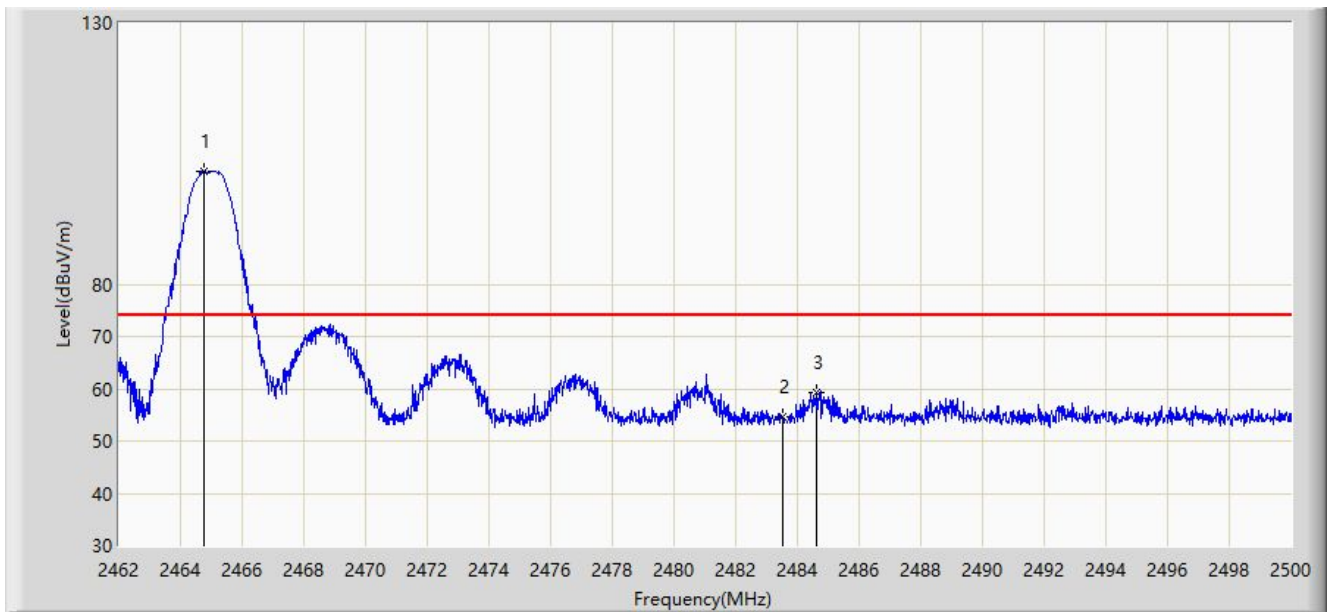

No	Flag	Mark	Frequency (MHz)	Measure Level (dBμV/m)	Reading Level (dBμV)	Duty Cycle Factor (dB)	Margin (dB)	Limit (dBμV/m)	Factor (dB/m)	Type
1		*	2464.774	101.705	70.743	N/A	N/A	N/A	30.963	PK
2			2483.500	54.515	23.494	N/A	-19.485	74.000	31.021	PK
			2483.500	14.515	-16.506	-40.000	-39.485	54.000	31.021	AV
3			2484.629	59.415	28.389	N/A	-14.585	74.000	31.025	PK
			2484.629	19.414	-11.611	-40.000	-34.586	54.000	31.025	AV

Note: Peak Measure Level (dBμV/m) = Reading Level (dBμV) + Factor (dB)

Average Measure Level (dBμV/m) = Reading Level (dBμV) + Factor (dB) + Duty Cycle Factor (dB)

Factor (dB/m) = Cable Loss (dB) + Antenna Factor (dB/m)

Site: WZ-AC1	Time: 2021/10/26 - 19:04
Limit: FCC_Part15_Band Edge(3m)	Engineer: Lucas Wang
Probe: WZ-AC1_BBHA9120D_1-18GHz	Polarity: Horizontal
EUT: SLT2 2CH TX	Power: By Battery
Test Mode: Transmit at channel 57 (2480MHz).	

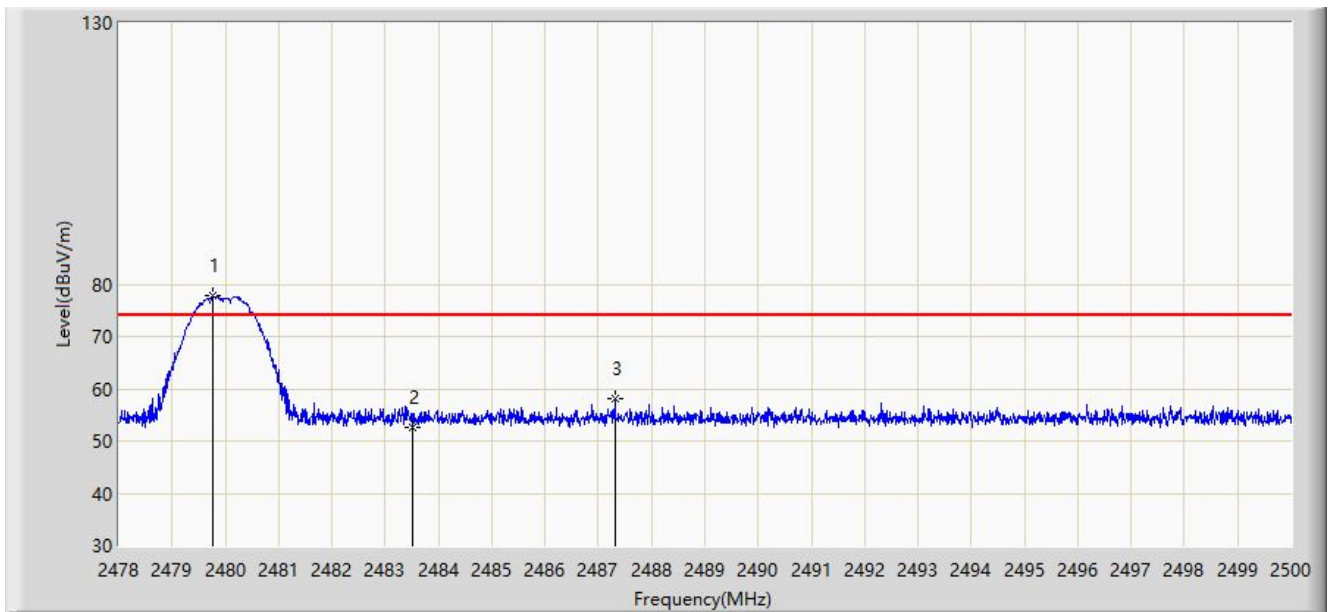

No	Flag	Mark	Frequency (MHz)	Measure Level (dBuV/m)	Reading Level (dBuV)	Duty Cycle Factor (dB)	Margin (dB)	Limit (dBuV/m)	Factor (dB/m)	Type
1		*	2479.771	77.732	46.727	N/A	N/A	N/A	31.005	PK
2			2483.500	52.618	21.597	N/A	-21.382	74.000	31.021	PK
			2483.500	12.618	-18.403	-40.000	-41.382	54.000	31.021	AV
3			2487.317	58.096	27.059	N/A	-15.904	74.000	31.037	PK
			2487.317	18.096	-12.941	-40.000	-35.904	54.000	31.037	AV

Note: Peak Measure Level (dBuV/m) = Reading Level (dBuV) + Factor (dB)

Average Measure Level = Peak Measure Level + Duty Cycle Factor

Factor (dB/m) = Cable Loss (dB) + Antenna Factor (dB/m)

Site: WZ-AC1	Time: 2021/10/26 - 19:10
Limit: FCC_Part15_Band Edge(3m)	Engineer: Lucas Wang
Probe: WZ-AC1_BBHA9120D_1-18GHz	Polarity: Vertical
EUT: SLT2 2CH TX	Power: By Battery
Test Mode: Transmit at channel 57 (2480MHz).	

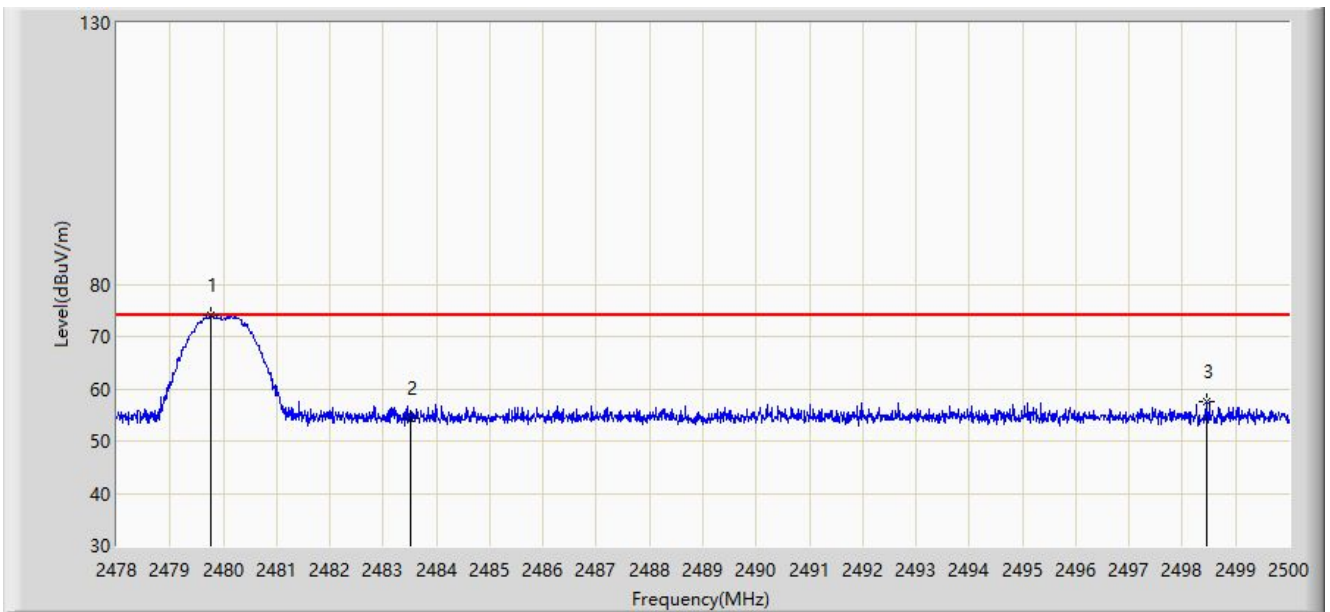

No	Flag	Mark	Frequency (MHz)	Measure Level (dBuV/m)	Reading Level (dBuV)	Duty Cycle Factor (dB)	Margin (dB)	Limit (dBuV/m)	Factor (dB/m)	Type
1		*	2479.771	73.973	42.968	N/A	N/A	N/A	31.005	PK
2			2483.500	54.395	23.374	N/A	-19.605	74.000	31.021	PK
			2483.500	14.395	-16.626	-40.000	-39.605	54.000	31.021	AV
3			2498.449	57.565	26.491	N/A	-16.435	74.000	31.074	PK
			2498.449	17.565	-13.509	-40.000	-36.435	54.000	31.074	AV

Note: Peak Measure Level (dBuV/m) = Reading Level (dBuV) + Factor (dB)

Average Measure Level = Peak Measure Level + Duty Cycle Factor

Factor (dB/m) = Cable Loss (dB) + Antenna Factor (dB/m)

5.8. AC Conducted Emissions Measurement

5.8.1. Test Limit

FCC Part 15 Subpart C Paragraph 15.207 Limits		
Frequency (MHz)	QP (dB μ V)	AV (dB μ V)
0.15 - 0.50	66 - 56	56 - 46
0.50 - 5.0	56	46
5.0 - 30	60	50

Note 1: The lower limit shall apply at the transition frequencies.

Note 2: The limit decreases linearly with the logarithm of the frequency in the range 0.15MHz to 0.5MHz.

5.8.2. Test Setup

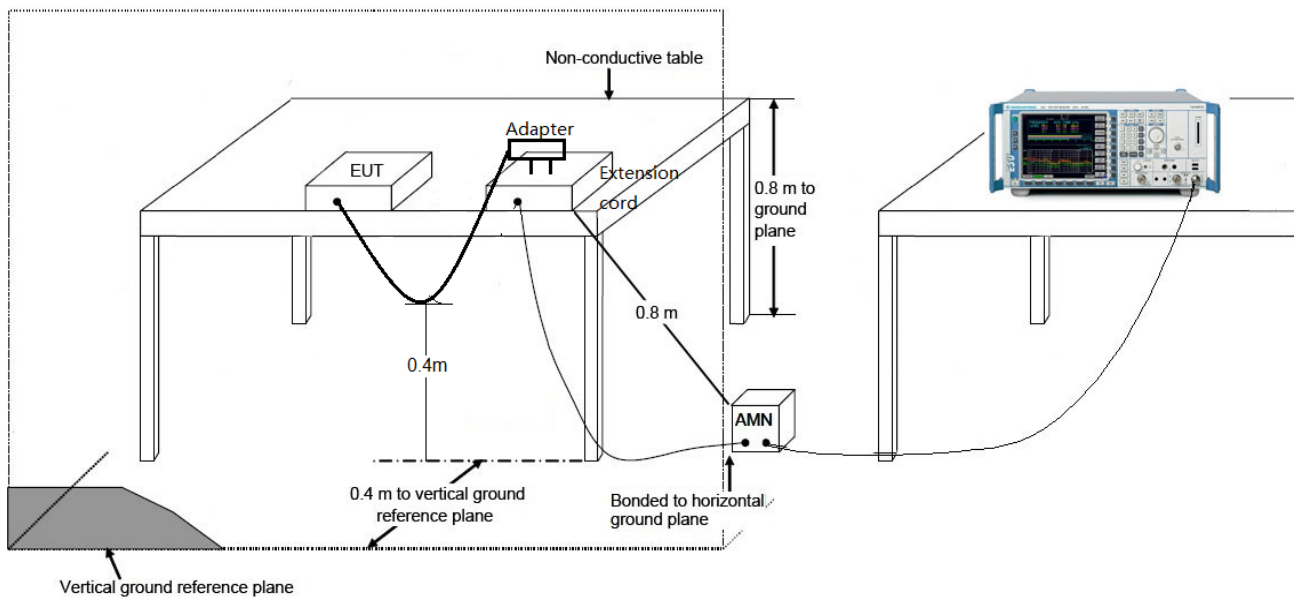

5.8.3. Test Result

The EUT is powered by 4*AA battery, so this test item is not applicable.

6. CONCLUSION

The data collected relate only the item(s) tested and show that the device is compliance with Part 15C of the FCC rules and ISED rules.

————— The End —————

Appendix A - Test Setup Photograph

Refer to "2108RSU036-UT" file.

Appendix B - EUT Photograph

Refer to " 2108RSU036-UE" file.