

Designated by Ministry of international Trade and industry

KANSAI ELECTRONIC INDUSTRY DEVELOPMENT CENTER

HEAD OFFICE
6-8-7 NISHITENMA
KITA-KU OSAKA 530-0047 JAPAN



IKOMA TESTING LABORATORY
12128 TAKAYAMA-CHO
IKOMA-CITY NARA 630-0101 JAPAN

Corporate Juridical Person

TEST REPORTReport No. A-007-00-C

Date: 3 March 2000

This test report is to certify that the tested device properly complies with the requirements of:

FCC Rules and Regulations Part 95 : Radio Control (R/C) Radio Service.

The tests necessary to show compliance to the requirements were performed and these results met the specifications of requirement. The results of this report should not be construed to imply compliance of equipment other than that, which was tested. Unless the laboratory permission, this report should not be copied in part.

1. Applicant

Company Name : JAPAN REMOTE CONTROL CO., LTD.

Mailing Address : 2-2-12, EIWA, HIGASHIOSAKA-CITY, OSAKA, 577-0809 JAPAN

2. Identification of Tested Device

Type of Device : Radio Control (R/C) Radio Service.
 Kind of Equipment Authorization : : DoC : Certification : Verification
 FCC ID : BRWQUATTRO
 Device Name : FM 4 CHANNEL TRANSMITTER
 Trade Name : JR PROPO
 Model Number : QUATTRO
 Serial Number : No.1 : Prototype : Pre-production : Production
 Date of Manufacture : February, 2000

3. Test Items and Procedure

: Measurement of RF Power Output (Substitution Method)
: Modulation Characteristics
: Necessary Bandwidth
: Emission Bandwidth
: Measurement of Field Strength of Spurious Radiation
: Frequency Stability Measurement

Above all tests were performed under: FCC Part 2 Sec2.1046, Sec2..1047,
 Sec2.1049, Sec2.1053, Sec2.1055 and Sec2.1057.

: without deviation, : with deviation(details are found inside of this report)

4. Date of Test

Receipt of Test Sample : 14 February 2000
 Test Completed on : 1 March 2000

Eizo Hariya
 General Manager of Ikoma Testing Laboratory

Table of Contents

1. GENERAL INFORMATION.....	3
1.1 Product Description.....	3
1.2 Description for Equipment Authorization	3
1.3 Test Facility.....	3
2. TESTED SYSTEM.....	4
2.1 Test Mode	4
2.2 Block Diagram of EUT System.....	4
2.3 List of EUT System.....	5
2.4 List of Antenna	5
3. RF POWER OUTPUT.....	6
3.1 Reference Rule and Specification.....	6
3.2 Test Configuration	6
3.3 Test Procedure.....	7
3.4 Test Results.....	8
4. MODULATION CHARACTERISTICS.....	9
4.1 Reference Rule and Specification.....	9
4.2 Test Results.....	9
5. NECESSARY BANDWIDTH	10
5.1 Reference Rule and Specification.....	10
5.2 Test Configuration	10
5.3 Test Results.....	11
6. EMISSION BANDWIDTH	13
6.1 Reference Rule and Specification.....	13
6.2 Test Configuration	13
6.3 Test Results.....	14
7. FIELD STRENGTH OF SPURIOUS RADIATION	18
7.1 Reference Rule and Specification.....	18
7.2 Test Procedure	18
7.3 Test Configuration	19
7.4 Photographs of EUT System Configuration	20
7.5 Test Results.....	22
8. FREQUENCY STABILITY MEASUREMENT	23
8.1 Reference Rule and Specification.....	23
8.2 Frequency vs Temperature Test.....	23
8.3 Frequency vs Voltage Test.....	24
9. LIST OF TEST INSTRUMENTS	25

1. GENERAL INFORMATION

1.1 Product Description

The Model No. QUATTRO (referred as EUT in this report) is the FM 4 CHANNEL TRANSMITTER.

(1) Technical Specifications

Transmitting Frequency : 72.00 ~ 73.00 MHz (72.55 MHz in EUT)
Designation of Emission : 4K63F1D

(2) Contained Oscillator

OVER-TONE : 18.1375 MHz

(3) Rated Power Supply : DC 9.6 V (Ni-Cd battery)

1.2 Description for Equipment Authorization

(1) Rules Part(s) under which Equipment operated

FCC Rule Part 95 ; Radio Control(R/C) Radio Service

(2) Kind of Equipment Authorization

Certification Verification

(3) Procedure of Application

Original Equipment Modification

1.3 Test Facility

Name : KANSAI ELECTRONIC INDUSTRY DEVELOPMENT CENTER (KEC)
IKOMA TESTING LABORATORY
Open Test Site No.1

Address : 12128, Takayama-cho Ikoma-city, Nara, 630-0101 Japan

This test facility has been filed in FCC under the criteria in ANSI C63.4-1992.
The laboratory has been accredited by the NVLAP(Lab.Code:200207-0) based on ISO/IEC Guide 25.

2. TESTED SYSTEM

2.1 Test Mode

The compliance tests were performed under the following operation mode.

(1) Measurement of Field Strength of Spurious Radiation :

The EUT was continuously transmitted in modulation mode.

(2) Frequency Stability Measurement :

The EUT was continuously transmitted in non-modulation mode.

(3) Except above two test items :

See the page of each test items.

2.2 Block Diagram of EUT System

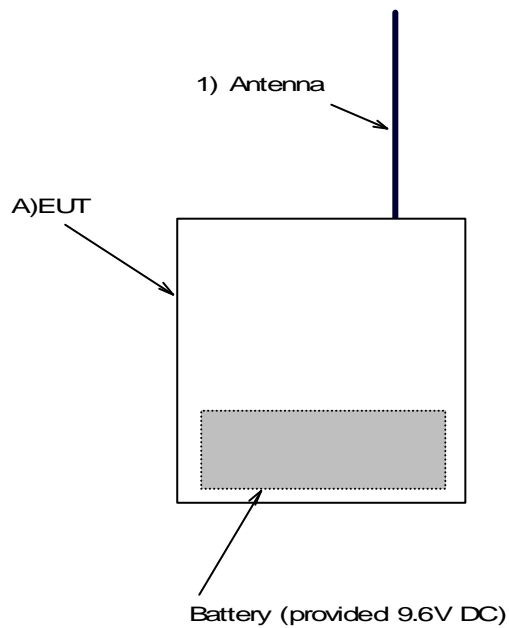

[Note]

See 2.3 List of EUT System and 2.4 List of Antenna.

2.3 List of EUT System

No	Device Name	Model Number (Serial Number)	FCC ID (Trade Name)	Note	Remark
A	FM 4 CHANNEL TRANSMITTER	QUATTRO (No.1)	BRWQUATTRO (JR PROPO)	Battery : Ni-Cd 9.6V	(1)

[Remark]

(1) : EUT

2.4 List of Antenna

No	Type	Length (m)	Note	Remark
1	Built-in Rod Antenna	0.80		(1)

[Remark]

(1) : Accessory of EUT

3. RF POWER OUTPUT

3.1 Reference Rule and Specification

FCC Rule Part 95 [Section95.639] and Part 2 Subpart J [Section2.1046]

3.2 Test Configuration

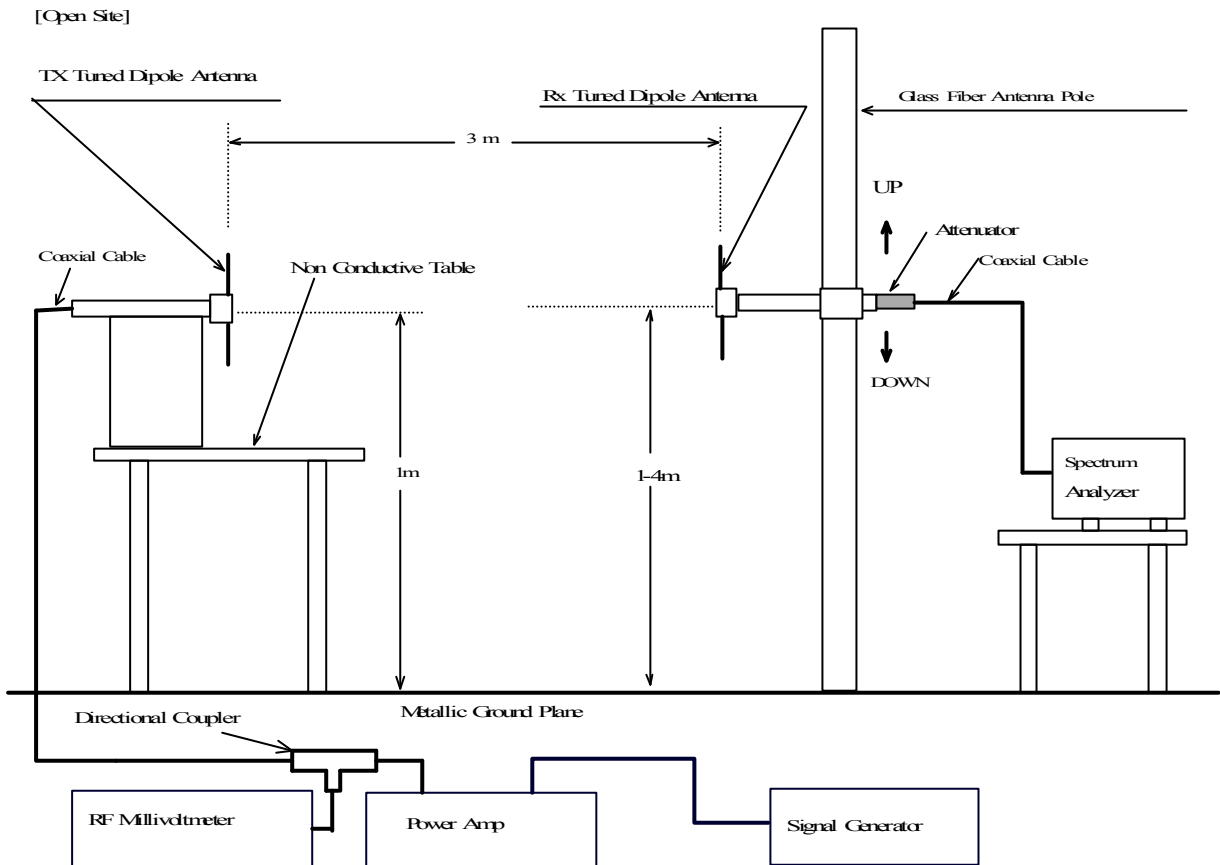

3.3 Test Procedure

- (1) Tune-up the transmitter.
- (2) The receiving antenna is adjusted to the correct length for the carrier frequency.
- (3) Raise and lower the receiving antenna to obtain a maximum reading on the Spectrum Analyzer with the antenna at horizontal polarity. Then the turntable is rotated to further increase this maximum reading. Repeat this procedure of raising and lower the antenna and rotating the turntable until the highest possible signal has been obtain.
Record this maximum reading.
- (4) Repeat step3 with the antenna polarized vertically.
- (5) Remove the transmitter and replace it with the half-wave antenna. The center of these antennas are approximately at the same location as the center of the transmitter.
- (6) Feed the half-wave antenna at the transmitter end with a signal generator connected to the antenna by means of a non-radiating cable.
With the antennas at both ends horizontally polarized and with the signal generator tuned to the carrier frequency, raise and lower the receiver antenna to obtain a maximum reading at the Spectrum Analyzer. Adjust the level of the signal generator output until the previous recording maximum reading for this set of conditions its obtained.
- (7) Repeat step6 with both antennas vertically polarized.

3.4 Test Results

CARRIER FREQUENCY [MHz]	SPECTRUM ANALYZER READING [dBmV]		RF METER READING [dBm]		CABLE LOSS [dB]	RF OUTPUT POWER [mW]	LIMIT [mW]
	Horiz.	Vert.	Horiz.	Vert.			
	72.55	110.3	107.7	22.1			

The RF Power Output can be calculated from following formula:

$$\text{RF Power (mW)} = \frac{(\text{Mr} - \text{Lo}) \div 10}{10}$$

where,

Mr: RF Meter Reading (dBm)

Lo: Loss of Cable (dB)

[Environment]

Temperature : 17 °C Humidity : 53 %

[Summary of Test Results]

Above data shows that the test device complies with the requirements.

Minimum margin was 7.2 dB, horizontal polarization.

Tested Date : 14 February 2000

Tester Signature

Yasunari Kawai

4. MODULATION CHARACTERISTICS

4.1 Reference Rule and Specification

FCC Rule Part 2 Subpart J [Section2.1047]

4.2 Test Results

Encoded Waveform

(1) Operation Mode of EUT

Normal Modulation

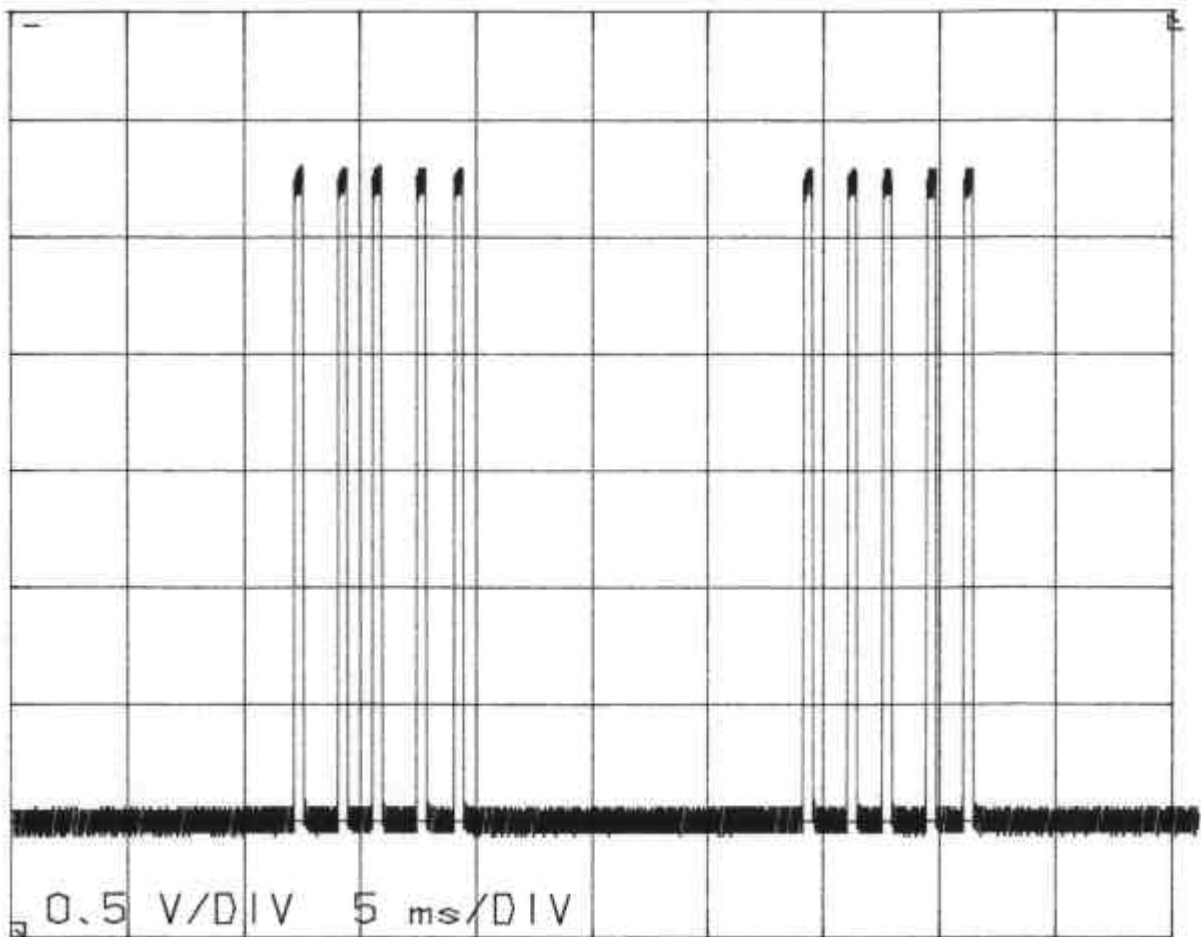

5. NECESSARY BANDWIDTH

5.1 Reference Rule and Specification

FCC Rule Part 95 Subpart E [§ 95.633(b)]

5.2 Test Configuration

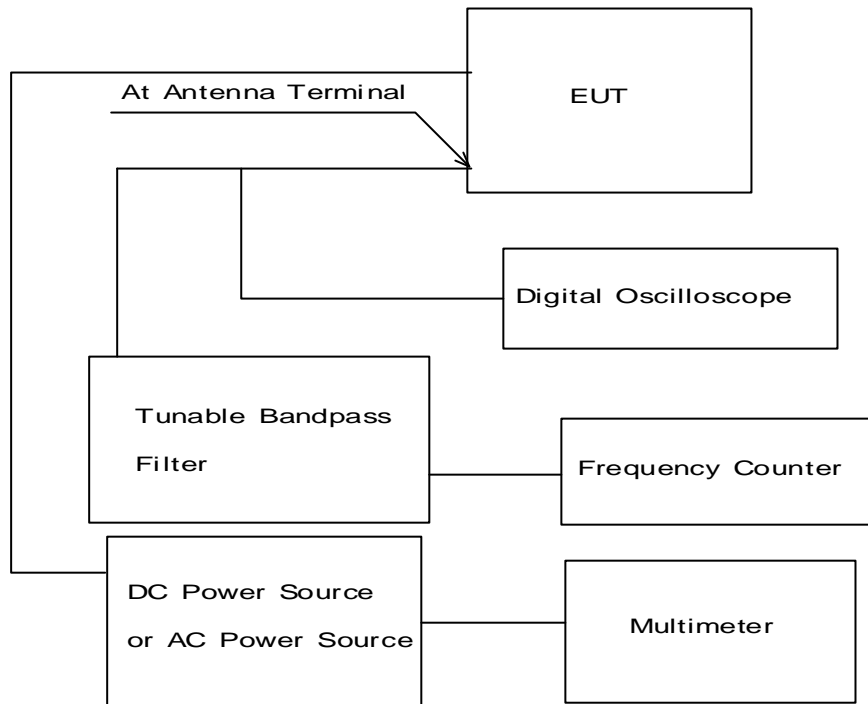

5.3 Test Results

1) Measurement of the Peak Frequency Deviation(D)

Flow (low frequency of carrier) : 72.548311 [MHz]
Fhigh (high frequency of carrier) : 72.551612 [MHz]

[Environment]

Temperature : 20°C Humidity : 57%

[Calculation of the Peak Frequency Deviation]

$$D = (F_{\text{high}} - F_{\text{low}}) / 2 = 1.65 \text{ [kHz]}$$

D [kHz] : the Peak Frequency Deviation

- Continued -

2) Measurement of the Maximum Modulation Frequency (M)

Encoded Waveform
(See the Test Results of 4. MODULATION CHARACTERISTICS)

[Environment]

Temperature : 20°C Humidity : 57%

[Calculation of the Maximum Modulation Frequency]

From Encoded Waveform, the Modulation Pulse Width (most minimum) was read on the plotted graph.

$$T = 4.6 \text{ [mm]} / 15.3 \text{ [mm / DIV]} \times 5 \text{ [ms / DIV]}$$

$$= 1.50 \text{ [ms]}$$

$$M = 1 / T$$

$$= 0.667 \text{ [kHz]}$$

T [ms] : the Modulation Pulse Width (most minimum)

M [kHz] : the Maximum Modulation Frequency

3) Calculation of the Necessary Bandwidth (B)

From the result 1) and 2), the Necessary Bandwidth (B) was calculated as follows

$$B = 2M + 2D = 4.63 \text{ [kHz]}$$

B [kHz] : the Necessary Bandwidth

[Summary of Test Result]

Above test results show that the Necessary Bandwidth is less than 8.0 kHz

Tested Date : 1March 2000

Tester Signature

Yasunari Kawai

6. EMISSION BANDWIDTH

6.1 Reference Rule and Specification

FCC Rule Part 95 [Section95.633], [Section95.635] and Part 2 Subpart J [Section2.1049]

6.2 Test Configuration

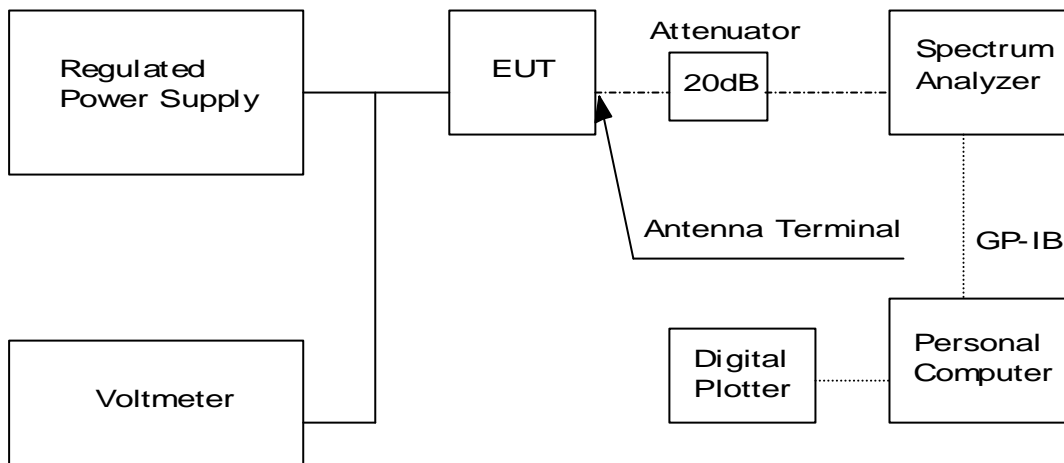

6.3 Test Results

See next figure (the picture of spectrum analyzer)

Occupied Bandwidth

The OBW was measured by the spectrum analyzer TR4172 which could measure 99% occupied bandwidth (OBW).

There are 1001 data on horizontal axis of display.

One of them is V_n . Then total power P can be calculated from the following formula.

$$P = \sum_{n=1}^{1001} \frac{V_n^2}{R} \dots\dots\dots (1)$$

where, R is input impedance of TR4172.

Let, x is the point which gives 0.5% of the total power and Y is the point which gives 99.5% of the total power. Then we can get the following formula.

$$0.005P = \sum_{n=1}^x \frac{V_n^2}{R} \dots\dots\dots (2)$$

$$0.995P = \sum_{n=1}^y \frac{V_n^2}{R} \dots\dots\dots (3)$$

From(1)- (3), OBW becomes .

$$OBW = \frac{Fspan(Y - X)}{1000}$$

where, F_{span} is frequency span of the spectrum analyzer.

Operation Mode of EUT

Normal modulation

EUT was operated the various positions of JOY STICK & OTHER SWITCHES.(Reference level is the unmodulated level.)

Trace mode of Spectrum Analyzer : Maximum Hold

Occupied Bandwidth = 5.5kHz (99% Power)

M1=72.5475MHz(0.5% Power Point)

M2=72.553MHz(99.5% Power Point)

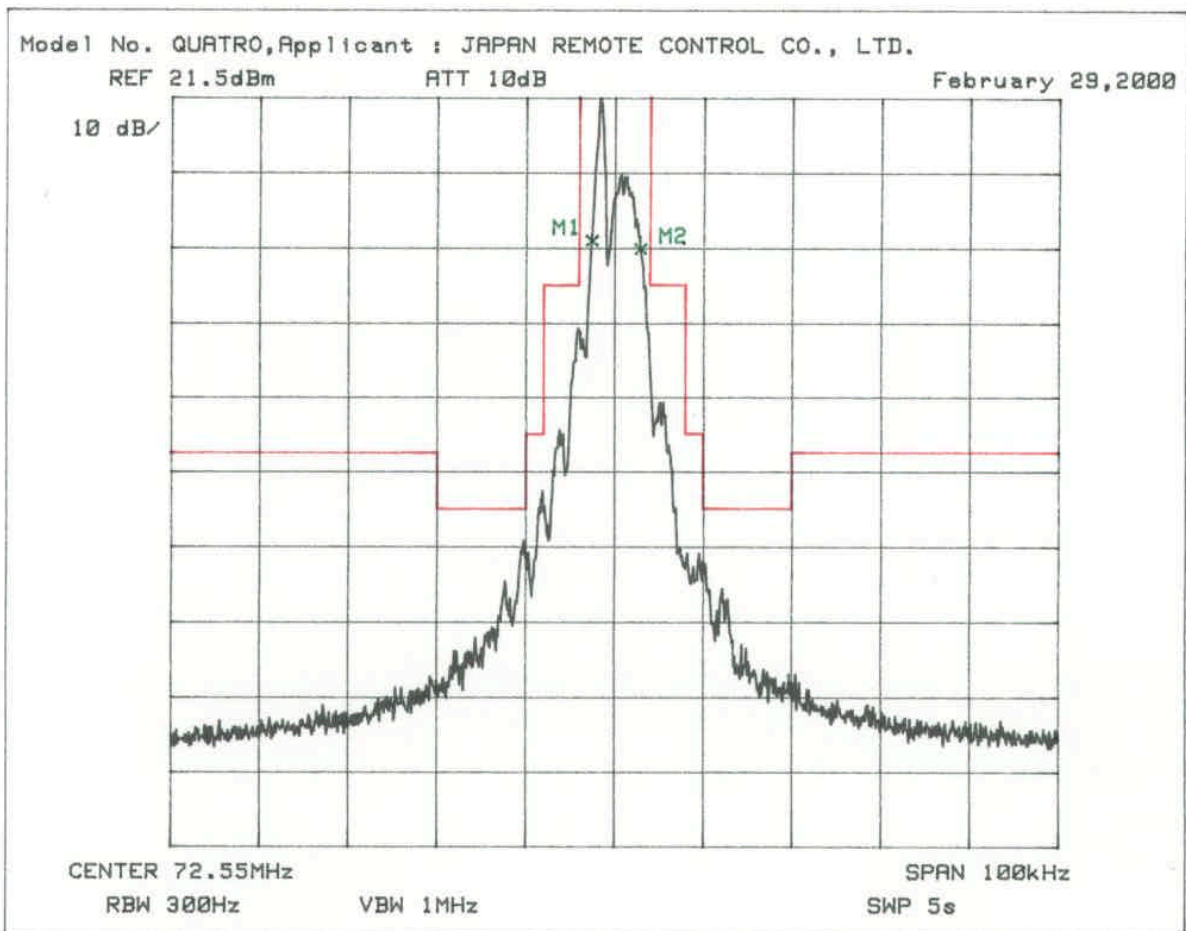

Operation Mode of EUT

Non modulation
[F Low]

Occupied Bandwidth = 1.1kHz (99% Power)

M1=72.5479MHz(0.5% Power Point)

M2=72.549MHz(99.5% Power Point)

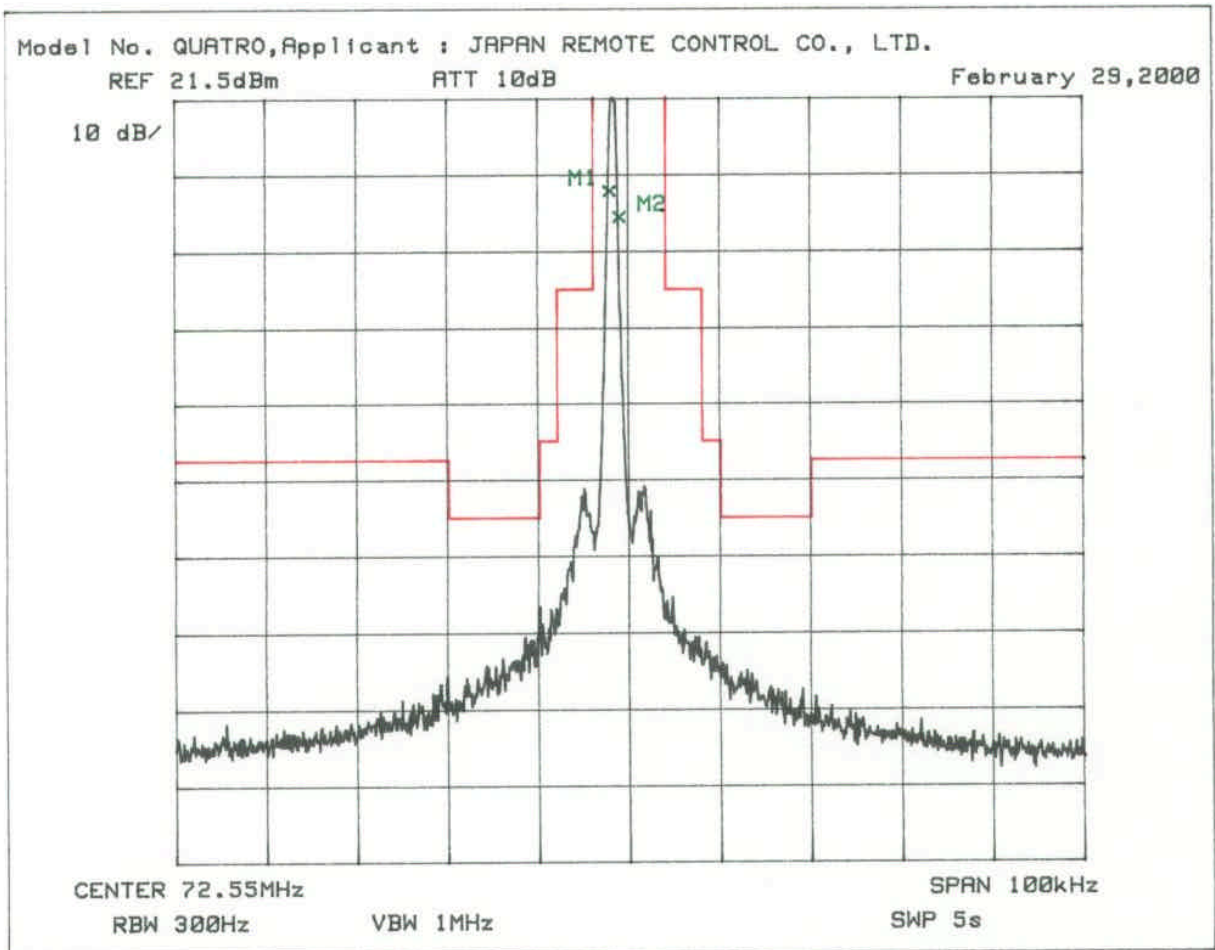

Operation Mode of EUT

Non modulation
[F High]

Occupied Bandwidth = .9kHz (99% Power)

M1=72.5512MHz(0.5% Power Point)

M2=72.5521MHz(99.5% Power Point)

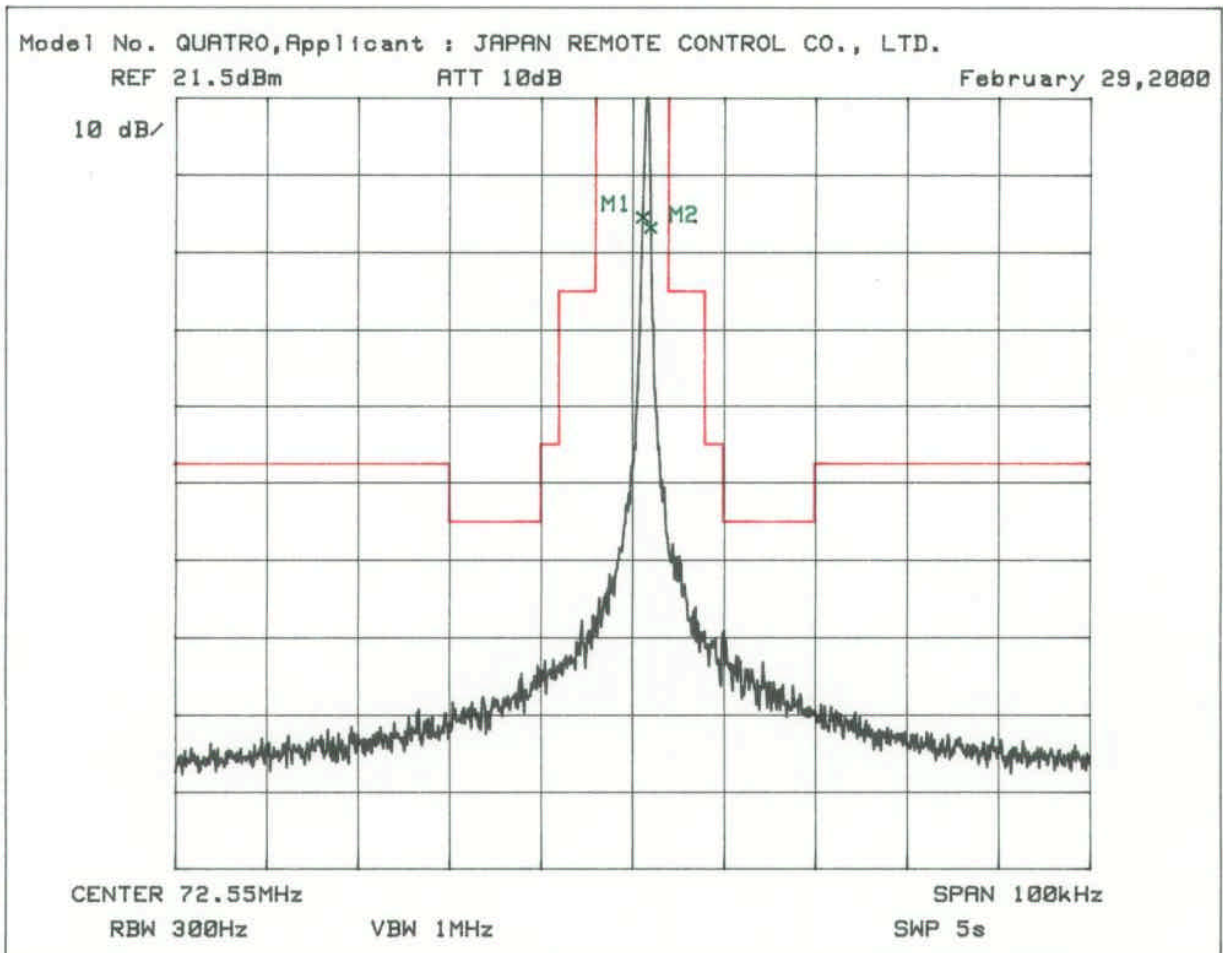

7. FIELD STRENGTH OF SPURIOUS RADIATION

7.1 Reference Rule and Specification

FCC Rule Part 95 [Section 95.635] and Part 2 Subpart J [Section 2.1053]

7.2 Test Procedure

- (1) Tune-up the transmitter(EUT).
- (2) Device Vertical : Place the device so that it's longest axis is vertical.
- (3) For each spurious measurement the receiving antenna is adjusted to the correct length for the frequency involved. These measurements are made from the lowest radio frequency generated in the EUT or 25MHz to the tenth harmonic of the carrier.
- (4) For each spurious frequency, raise and lower the receiving antenna to obtain a maximum reading on the spectrum analyzer with the antenna at horizontal polarity. Then the turntable is rotated to further increase this maximum reading. Repeat this procedure of raising and lower the antenna and rotating the turntable until highest possible signal has been obtain. Record this maximum reading.
- (5) Repeat Step4 for each spurious frequency with the antennae polarized vertically.
- (6) Device Horizontal : Place the device so that it's longest axis is horizontal.
- (7) Repeat Step3, Step4, and Step5
- (8) The attenuation of the spurious in dB can be calculated from the following formula:

$$\begin{array}{rcl} \text{Spurious Emission} & & \text{Field Strength} \\ \text{Attenuation} & = & \text{of Carrier Emission} \\ \text{[dB]} & & \text{[dB}\mu\text{V/m]} \end{array} \quad - \quad \begin{array}{r} \text{Field Strength} \\ \text{of Spurious Emission} \\ \text{[dB}\mu\text{V/m]} \end{array}$$

7.3 Test Configuration

[Open Site]

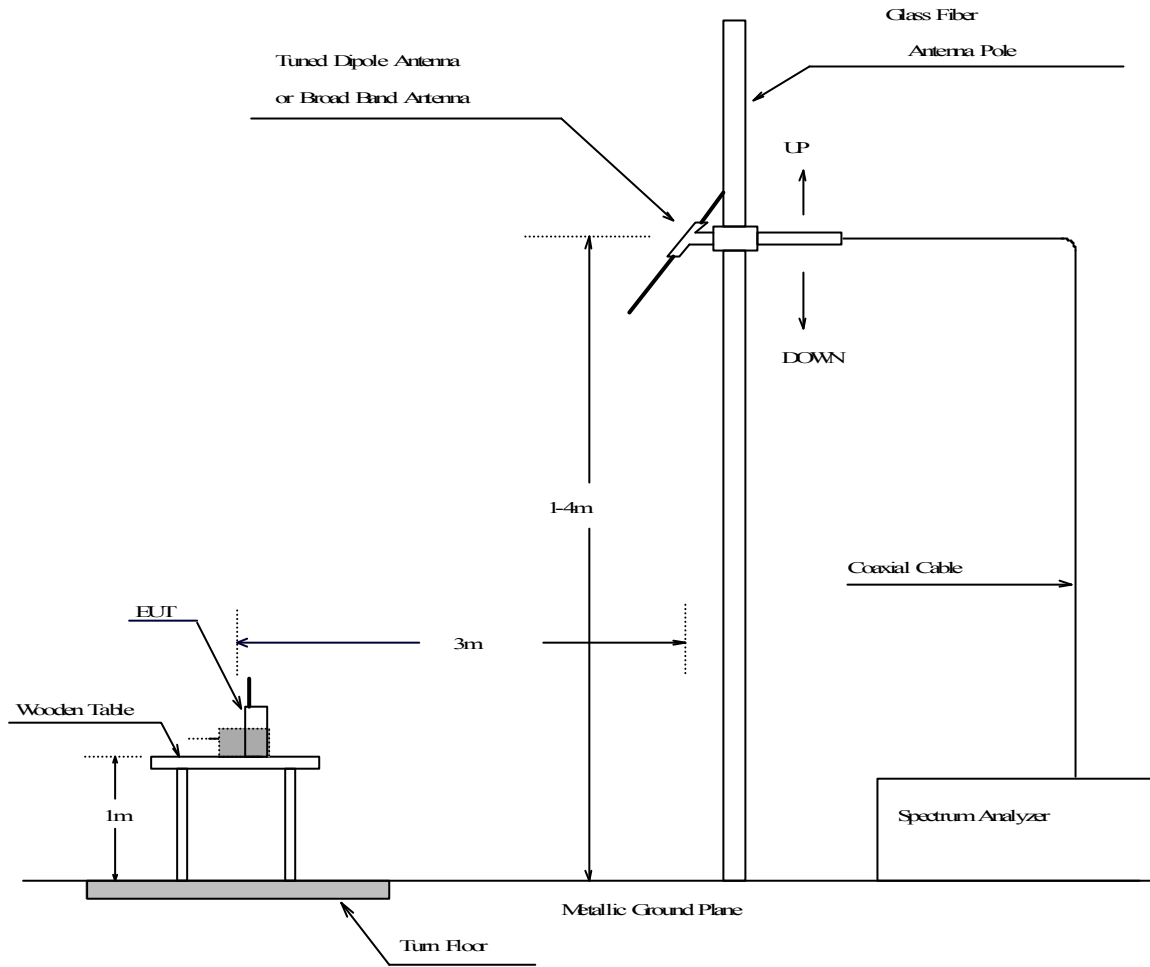

7.4 Photographs of EUT System Configuration

Horizontal Placing

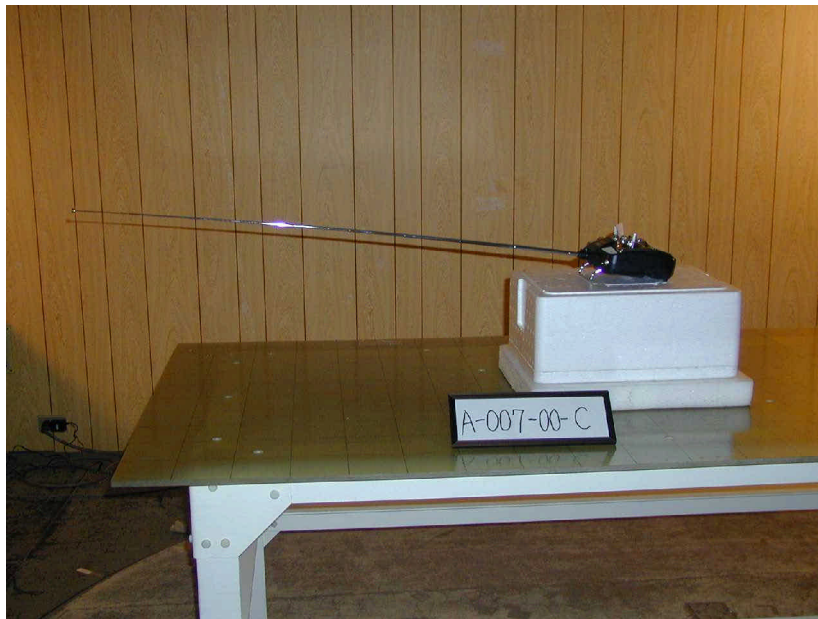

Vertical Placing

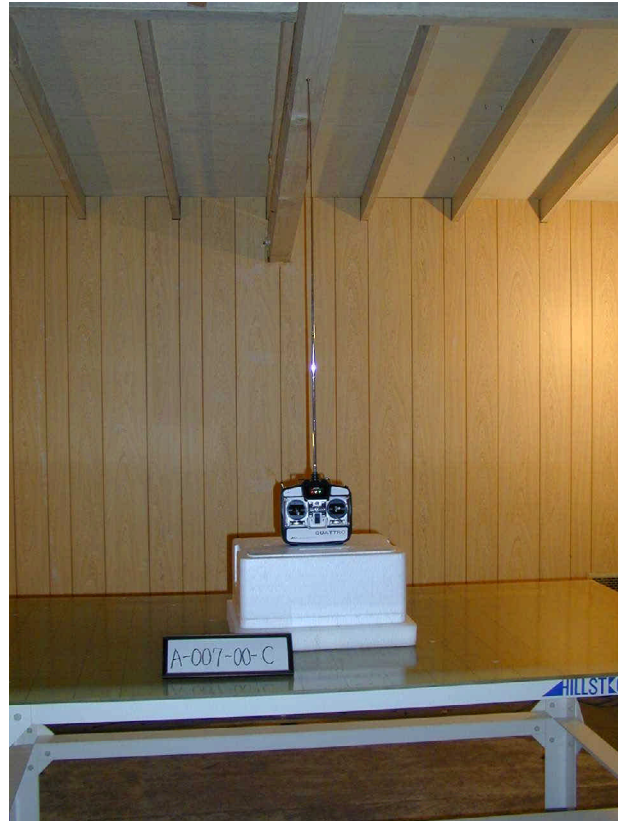

7.5 Test Results

Measured Frequency	Antenna Factor	Meter Reading		Maximum Field Strength	Attenuation From Carrier	Limits	Margin for Limits
		Horizontal	Vertical				
(MHz)	(dB/m)	(dBmV)	(dBmV)	(dBmV/m)	(dB)	(dBmV/m)	(dB)
<u>Carrier Emission</u>							
72.55	7.5	110.3	107.7	117.8	-	-	-
<u>Spurious Emission</u>							
54.42	20.8	42.1	41.8	62.9	54.9	47.5	7.4
108.83	23.3	31.4	28.0	54.7	63.1	47.5	15.6
145.08	26.8	32.3	30.3	59.1	58.7	47.5	11.2
181.38	28.5	31.9	25.0	60.4	57.4	47.5	9.9
217.65	29.5	33.9	35.7	65.2	52.6	47.5	5.1
326.47	18.2	35.1	33.0	53.3	64.5	47.5	17.0
362.74	19.2	35.7	38.5	57.7	60.1	47.5	12.6
435.10	20.9	24.1	25.4	46.3	71.5	47.5	24.0
507.85	22.7	39.1	36.5	61.8	56.0	47.5	8.5
580.40	24.2	36.1	33.1	60.3	57.5	47.5	10.0
616.68	24.8	24.6	20.5	49.4	68.4	47.5	20.9
652.95	25.3	25.1	22.0	50.4	67.4	47.5	19.9
725.55	26.4	28.2	24.7	54.6	63.2	47.5	15.7

[Note]

Limit of the attenuation of the spurious in dB:

$$56 + 10\text{Log}(\text{Power}) = 56 + 10\text{Log}(0.1413) = 47.5 \text{ dB}$$

[Environment]

Temperature : 20°C Humidity : 53%

[Summary of Test Results]

Minimum Margin was 5.1 dB at 217.65 MHz, horizontal polarization.

Tested Date : 15 February 2000

Tester Signature

Yasunari Kawai

8. FREQUENCY STABILITY MEASUREMENT

8.1 Reference Rule and Specification

FCC Rule Part 95 [Section95.623] and Part 2 Subpart J [Section2.1055]

8.2 Frequency vs Temperature Test

Test Setup Diagram

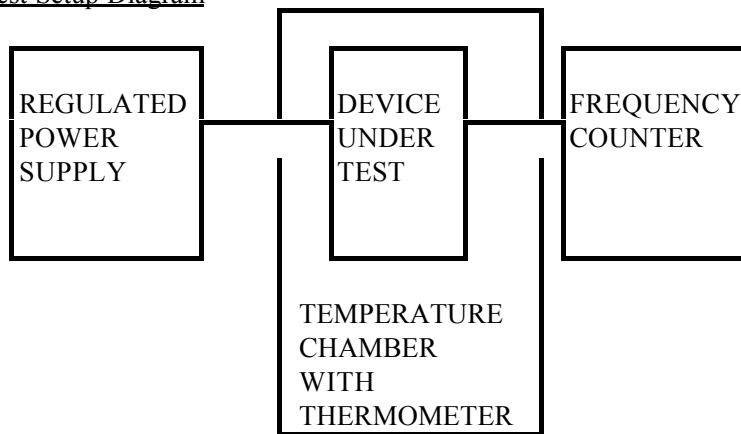

Test Result

Test Voltage: 9.6V

REFERENCE FREQUENCY [MHz]	TEMPERATURE [°C]	FREQUENCY DRIFT [%]	LIMIT [%]
<u>72.55</u>	-30	-0.000512	±0.002
	-20	-0.000071	
	-10	-0.000025	
	0	-0.000007	
	+10	0.000145	
	+20	-0.000053	
	+30	-0.000336	
	+40	-0.000569	
	+50	-0.000702	

8.3 Frequency vs Voltage Test

Test Setup Diagram : Same as (1)

Test Result

Temperature : +20°C

REFERENCE FREQUENCY [MHz]	SUPPLIED VOLTAGE [Volt]	FREQUENCY DRIFT [%]	LIMIT [%]
<u>72.55</u>	9.0	-0.000092	±0.002

Note Reduced primary supply voltage to the operating and point which shall be specified by the manufacturer.

[Environment] Temperature : 20°C Humidity : 57%

[Summary of Test Results]

Above data shows that the test device complies with the requirements.

Tested Date : 1 March 2000

Tester Signature

Yasunari Kawai

9. LIST OF TEST INSTRUMENTS

Instrument	Manufacturer	Model No	Specifications	KEC Control No.	if used, checked by "X".	Last Cal.	Next Cal.
Spectrum Analyzer	Advantest	TR4172	Frequency Range 50 Hz - 1.8 GHz	SA-27	<input checked="" type="checkbox"/>	1999/7	2000/7
Biconical Antenna	Schwarzbeck	BBA9106	Frequency Range 30 MHz - 300 MHz	AN-80	<input checked="" type="checkbox"/>	1999/2	2000/2
Log-Periodic	Schwarzbeck	UHALP 9107	Frequency Range 300 MHz - 1 GHz	AN-215	<input checked="" type="checkbox"/>	1999/2	2000/2
Tuned Dipole	Kyoritsu	KBA-511S	Frequency Range 25 MHz - 500 MHz	AN-135	<input checked="" type="checkbox"/>	1999/3	2000/3
	Kyoritsu	KBA-611S	Frequency Range 500 MHz - 1 GHz	AN-137	<input checked="" type="checkbox"/>	1999/3	2000/3
Tuned Dipole Antenna	Kyoritsu	KBA-511S	Frequency Range 25 MHz - 500 MHz	AN-134	<input checked="" type="checkbox"/>	1999/3	2000/3
Signal Generator	Anritsu	MG3601A	Frequency Range 0.1 MHz - 1040 MHz	SG-41	<input checked="" type="checkbox"/>	1999/9	2000/9
Power Amp.	ENI	601L	Frequency Range 0.8 MHz - 1 GHz	AM-24	<input checked="" type="checkbox"/>	1999/9	2000/9
RF Millivolt-Meter	Rohde & Schwarz	URV5	Frequency Range 10 kHz - 2 GHz	VV-29	<input checked="" type="checkbox"/>	1999/6	2000/6
Coaxial Cable	Suhner	SUCOFLEX 104	Length : 10m [SMA(p)-SMA(p)]	CL-46	<input checked="" type="checkbox"/>	2000/2	2001/2
Attenuator	Weinschel Engineering	2	Frequency Range 1 MHz - 20 GHz -10 dB	AT-42-1	<input checked="" type="checkbox"/>	1999/3	2000/3
Regurated DC Power Supply	Kikusui	PAB18-3A	Output 0-18V, 3A	PD-32	<input checked="" type="checkbox"/>	-	-
Temperature Chamber With Thermometer	Tabai Mfg.	MC-710	Temperature Range -75 - +100 °C	CH-31	<input checked="" type="checkbox"/>	-	-
Frequency Counter	Advantest	TR5823H	Freq.Range 1 mHz-1300 MHz	CU-17	<input checked="" type="checkbox"/>	1999/5	2000/5
Spectrum Analyzer	Advantest	TR4172	Frequency Range 50 Hz - 1.8 GHz	SA-27	<input checked="" type="checkbox"/>	1999/7	2000/7
Digital Ploterr	Hewlett Packard	7090A	Plot Area A3 size	RE-17	<input checked="" type="checkbox"/>	-	-
Multimeter	John Fluke	37	Volt Range 0.1mV - 1000 V Ampere Range 0.01 mA - 20 A	MM-91	<input checked="" type="checkbox"/>	1999/3	2000/3
Personal Computer	Hewlett Packard	9121	Memory 512kB Language BASIC	PC-38-2	<input checked="" type="checkbox"/>	-	-
Digital Oscilloscope	Matsushita Communication Ind.	VP-5740A	Frequency Range DC -10 MHz	OS-22	<input checked="" type="checkbox"/>	1999/5	2000/5