

PHILIPS

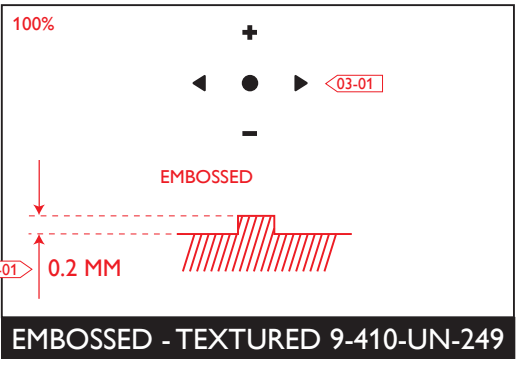

© 2011 Philips Consumer Electronics B.V. Alle rechten voorbehouden. All rights reserved. Reproduction in whole or in part is prohibited without the prior written consent of the copyright owner. Het is niet toegestaan dit te kopiëren of te verspreiden.

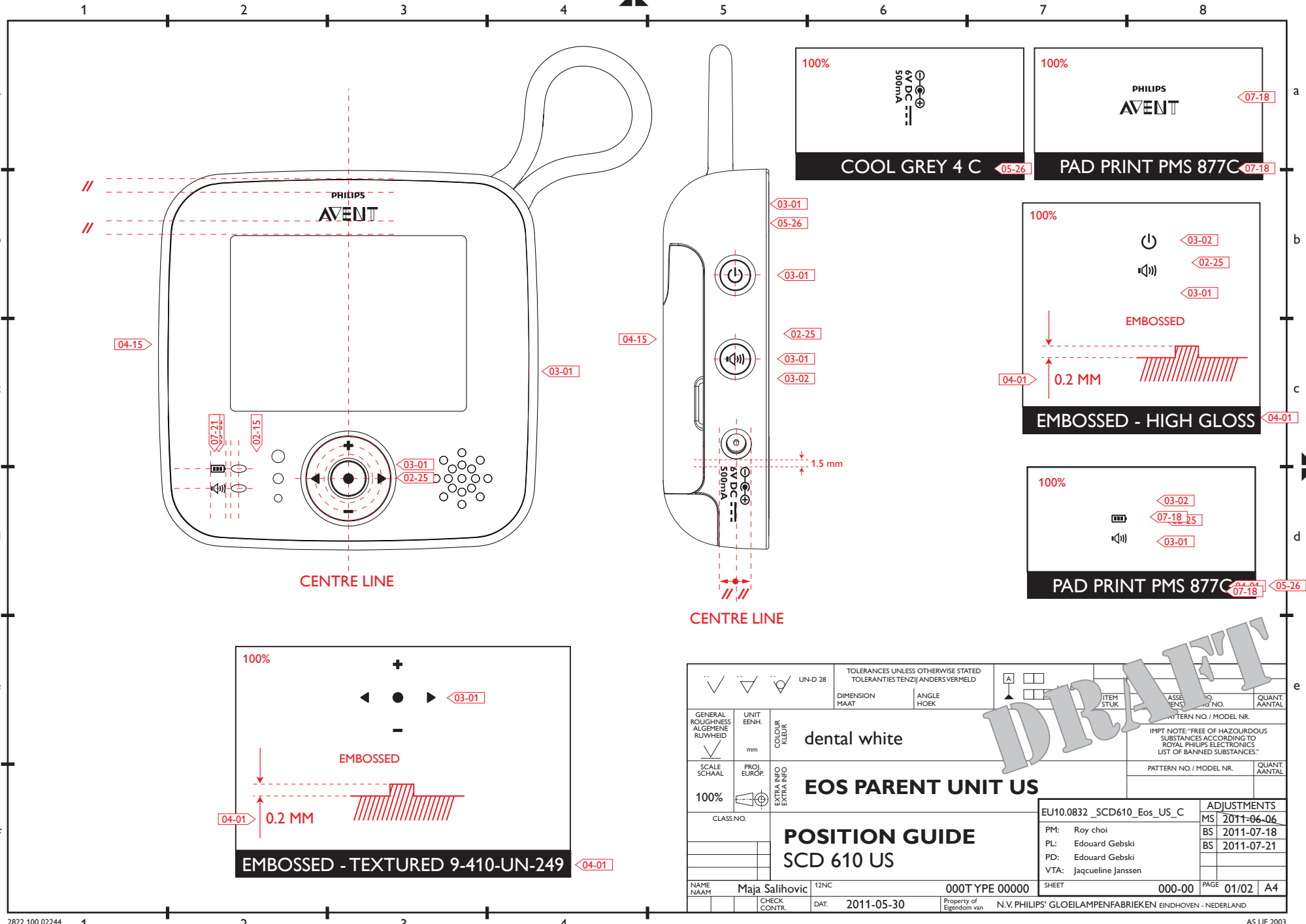

UN-D 28		TOLERANCES UNLESS OTHERWISE STATED TOLERANTIES TENZIJ ANDERS VERMELD		ITEM STUK		ASSEMBLY NO.		QUANT. AANTAL	
DIMENSION MAAT		ANGLE HOEK		PATTERN NO. / MODEL NR.		PATTERN NO. / MODEL NR.		QUANT. AANTAL	
GENERAL ROUGHNESS ALGEMENE RUWHEID		UNIT EENH. mm		COLOUR KLEUR dental white		IMPT NOTE: "FREE OF HAZARDOUS SUBSTANCES ACCORDING TO ROYAL PHILIPS ELECTRONICS LIST OF BANNED SUBSTANCES"			
SCALE SCHAAAL		PROJ. EUROR.		EXTRA INFO		PATTERN NO. / MODEL NR.		QUANT. AANTAL	
100%									
CLASS. NO.		POSITION GUIDE		EU10.0832_SCD610_Eos_US_C		ADJUSTMENTS			
		SCD 610 US				MS 2011-06-06			
NAME NAAM Maja Salihovic		12NC		000T YPE 00000		PM: Roy choi			
CHECK CONTR.		DAT. 2011-05-30		Property of Eigendom van N.V. PHILIPS' GLOEILAMPENFABRIEKEN EINDHOVEN - NEDERLAND		BS 2011-07-18			
				SHEET 000-00		PAGE 01/02 A4			

PHILIPS



© 2011 Philips Consumer Electronics B.V.  
 Alle rechten voorbehouden. Verwendingsrecht is  
 uitsluitend verleend voor de afbeelding op het  
 product en de afbeelding op het product.  
 Het is niet toegestaan deze afbeelding te kopiëren,  
 verspreiden of anderszins openbaar te maken.  
 Het is niet toegestaan deze afbeelding te verspreiden.  
 Het is niet toegestaan deze afbeelding te verspreiden.

1 2 3 4 5 6 7 8

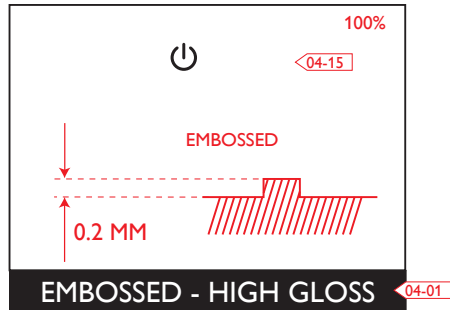
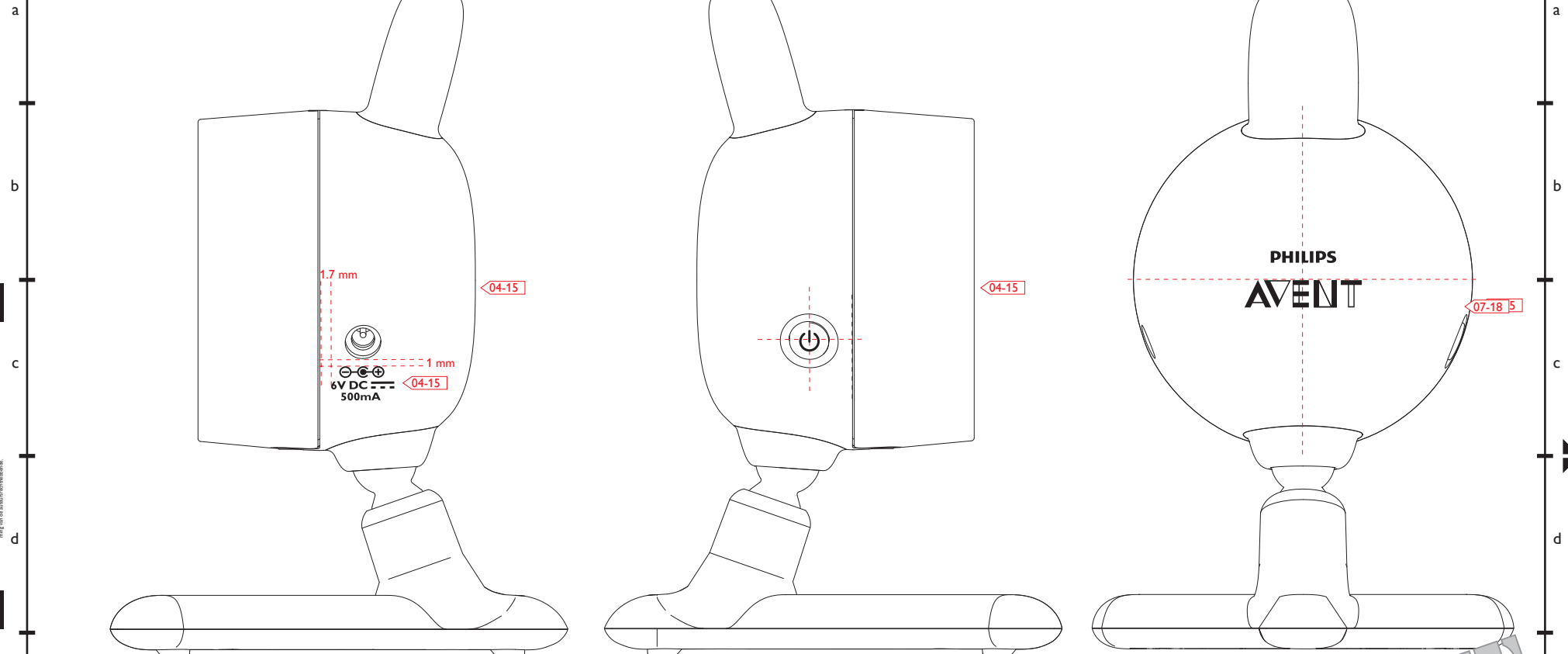

UN-D 28		TOLERANCES UNLESS OTHERWISE STATED TOLERANTIES TENZIJ ANDERS VERMELD		ITEM STUK		ASSEMBLY NO.		QUANTITY	
DIMENSION MAAT		ANGLE HOEK		PATTERN NO. / MODEL NR.		PATTERN NO. / MODEL NR.		QUANTITY	
GENERAL ROUGHNESS ALGEMENE RUWHEID		UNIT EENH.		COLOUR KLEUR		IMPT NOTE: "FREE OF HAZARDOUS SUBSTANCES ACCORDING TO ROYAL PHILIPS ELECTRONICS LIST OF BANNED SUBSTANCES"		QUANTITY	
SCALE SCHAAL		PROJ EUROR.		EXTRA INFO		PATTERN NO. / MODEL NR.		QUANTITY	
100%		mm		dental white		PATTERN NO. / MODEL NR.		QUANTITY	
CLASS.NO.		EOS BABY UNIT US		POSITION GUIDE SCD 610 US		ADJUSTMENTS		MS 2011-06-06	
NAME NAAM		Maja Salihovic		12NC		000T YPE 00000		BS 2011-07-18	
CHECK CONTR.		DAT.		2011-05-30		Property of Eigendom van		BS 2011-07-21	
						N.V. PHILIPS' GLOEILAMPENFABRIEKEN EINDHOVEN - NEDERLAND		VTA: Jaqueline Janssen	
						SHEET		000-00	
						PAGE		01/02	
						A4			

DRAFT

PHILIPS

©2011 Philips. Alle rechten voorbehouden. Reproduction is prohibited without the prior written consent of the copyright owner.

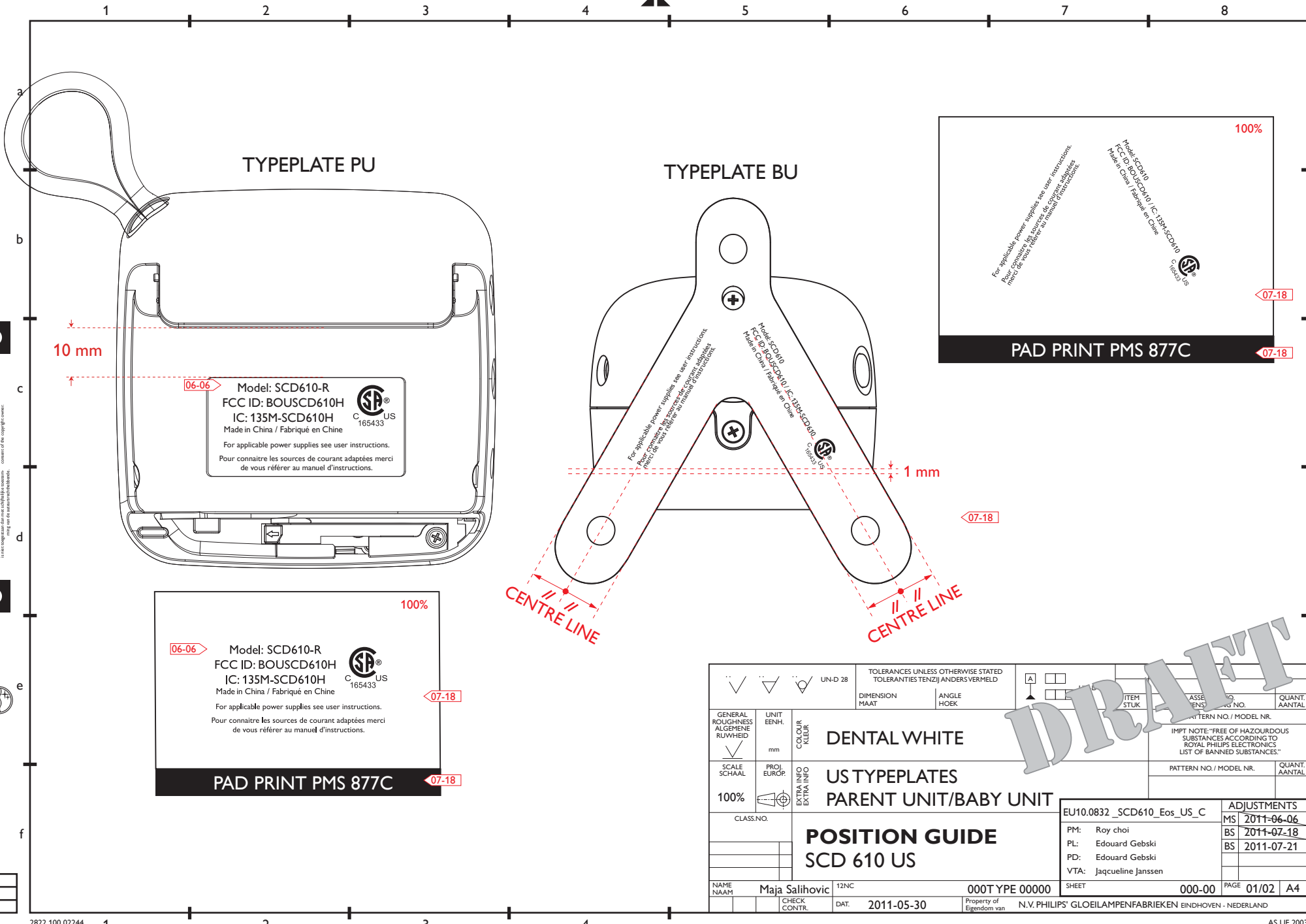

TYPEPLATE PU

TYPEPLATE BU

10 mm

06-06 Model: SCD610-R  
 FCC ID: BOUSCD610H  
 IC: 135M-SCD610H  
 Made in China / Fabriqué en Chine  
 For applicable power supplies see user instructions.  
 Pour connaître les sources de courant adaptées merci de vous référer au manuel d'instructions.

For applicable power supplies see user instructions.  
 Pour connaître les sources de courant adaptées merci de vous référer au manuel d'instructions.

Model: SCD610-R  
 FCC ID: BOUSCD610H / IC: 135M-SCD610H  
 Made in China / Fabriqué en Chine

PAD PRINT PMS 877C

06-06 Model: SCD610-R  
 FCC ID: BOUSCD610H  
 IC: 135M-SCD610H  
 Made in China / Fabriqué en Chine  
 For applicable power supplies see user instructions.  
 Pour connaître les sources de courant adaptées merci de vous référer au manuel d'instructions.

PAD PRINT PMS 877C

UN-D 28		TOLERANCES UNLESS OTHERWISE STATED TOLERANTIES TENZIJF ANDERS VERMELD		ITEM STUK		ASSEMBLY NO.		QUANT. AANTAL	
DIMENSION MAAT		ANGLE HOEK		PATTERN NO. / MODEL NR.		PATTERN NO. / MODEL NR.		QUANT. AANTAL	
GENERAL ROUGHNESS ALGEMENE RUWHEID		UNIT EENH. mm		COLOUR KLEUR		DENTAL WHITE		IMPT NOTE: "FREE OF HAZARDOUS SUBSTANCES ACCORDING TO ROYAL PHILIPS ELECTRONICS LIST OF BANNED SUBSTANCES."	
SCALE SCHAAAL		PROJ. EUROPE		EXTRA INFO EXTRA INFO		US TYPEPLATES PARENT UNIT/BABY UNIT		PATTERN NO. / MODEL NR.	
CLASS.NO.		NAME NAAM		12NC		000T YPE 00000		ADJUSTMENTS	
CHECK CONTR.		DAT.		2011-05-30		Property of Eigendom van		N.V. PHILIPS' GLOEILAMPENFABRIEKEN EINDHOVEN - NEDERLAND	
SHEET		000-00		PAGE		01/02		A4	

DRAFT