

Register your product and get support at
www.philips.com/welcome

HSB3280



Thank you for choosing Philips.

Need help fast?

Read your Quick Use Guide and/or Owner's Manual first for quick tips that make using your Philips product more enjoyable.

If you have read your instructions and still need assistance, you may access our online help at

www.philips.com/welcome
or call

1-888-PHILIPS (744-5477)
while with your product.
(and Model / Serial number)



Philips vous remercie de votre confiance.

Besoin d'une aide rapide?

Les Guide d'utilisation rapide et Manuel de l'utilisateur regorgent d'astuces destinées à simplifier l'utilisation de votre produit Philips. Toutefois, si vous ne parvenez pas à résoudre votre problème, vous pouvez accéder à notre aide en ligne à l'adresse

www.philips.com/welcome
ou formez le

1-800-661-6162 (Francophone)
1-888-PHILIPS (744-5477) (English speaking)
Veillez à avoir votre produit à portée de main.
(et model / serial nombre)



Gracias por escoger Philips

Necesita ayuda inmediata?

Lea primero la Guía de uso rápido o el Manual del usuario, en donde encontrará consejos que le ayudarán a disfrutar plenamente de su producto Philips.

Si después de leerlo aún necesita ayuda, consulte nuestro servicio de asistencia en línea en

www.philips.com/welcome
o llame al teléfono

1-888-PHILIPS (744-5477)
y tenga a mano el producto.
(y número de model / serial)

EN User manual

3



PHILIPS



Return your Product Registration Card or register online at
www.philips.com/welcome today to get the very most from your purchase.

Registering your model with PHILIPS makes you eligible for all of the valuable benefits listed below, so don't miss out. Complete and return your Product Registration Card at once, or register online at www.philips.com/welcome to ensure:

***Proof of Purchase**

Returning the enclosed card guarantees that your date of purchase will be on file, so no additional paperwork will be required from you to obtain warranty service.

***Product Safety Notification**

By registering your product, you'll receive notification - directly from the manufacturer - in the rare case of a product recall or safety defect.

***Additional Benefits**

Registering your product guarantees that you'll receive all of the privileges to which you're entitled, including special money-saving offers.

PHILIPS

Congratulations on your purchase, and welcome to the "family!"

Dear PHILIPS product owner:

Thank you for your confidence in PHILIPS. You've selected one of the best-built, best-backed products available today. We'll do everything in our power to keep you happy with your purchase for many years to come.

As a member of the PHILIPS "family," you're entitled to protection by one of the most comprehensive warranties and outstanding service networks in the industry. What's more, your purchase guarantees you'll receive all the information and special offers for which you qualify, plus easy access to accessories from our convenient home shopping network.

Most importantly, you can count on our uncompromising commitment to your total satisfaction.

All of this is our way of saying welcome - and thanks for investing in a PHILIPS product.

P.S. To get the most from your PHILIPS purchase, be sure to complete and return your Product Registration Card at once, or register online at:

www.philips.com/welcome

Know these
safety symbols



 This "bolt of lightning" indicates un-insulated material within your unit may cause an electrical shock. For the safety of everyone in your household, please do not remove product covering.

 The "exclamation point" calls attention to features for which you should read the enclosed literature closely to prevent operating and maintenance problems.

WARNING: To reduce the risk of fire or electric shock, this apparatus should not be exposed to rain or moisture and objects filled with liquids, such as vases, should not be placed on this apparatus.

CAUTION: To prevent electric shock, match wide blade of plug to wide slot, fully insert.

ATTENTION: Pour éviter les choc électriques, introduire la lame la plus large de la fiche dans la borne correspondante de la prise et pousser jusqu'au fond.

For Customer Use

Enter below the Serial No. which is located on the rear of the cabinet. Retain this information for future reference.

Model No. _____
Serial No. _____

PHILIPS Visit our World Wide Web Site at <http://www.philips.com/welcome>

PHILIPS LIMITED WARRANTY ONE (1) YEAR

WARRANTY COVERAGE:

PHILIPS warranty obligation is limited to the terms set forth below.

WHO IS COVERED:

Philips warrants the product to the original purchaser or the person receiving the product as a gift against defects in materials and workmanship as based on the date of original purchase ("Warranty Period") from an Authorized Dealer. The original sales receipt showing the product name and the purchase date from an authorized retailer is considered such proof.

WHAT IS COVERED:

The Philips warranty covers new products if a defect in material or workmanship occurs and a valid claim is received by Philips within the Warranty Period. At its option, Philips will either (1) repair the product at no charge, using new or refurbished replacement parts, or (2) exchange the product with a product that is new or which has been manufactured from new, or serviceable used parts and is at least functionally equivalent or most comparable to the original product in Philips current inventory, or (3) refund the original purchase price of the product. Philips warrants replacement products or parts provided under this warranty against defects in materials and workmanship from the date of the replacement or repair for ninety (90) days or for the remaining portion of the original product's warranty, whichever provides longer coverage for you. When a product or part is exchanged, any replacement item becomes your property and the replaced item becomes Philips' property. When a refund is given, your product becomes Philips' property.

Note: Any product sold and identified as refurbished or renewed carries a ninety (90) day limited warranty.

Replacement product can only be sent if all warranty requirements are met. Failure to follow all requirements can result in delay.

WHAT IS NOT COVERED - EXCLUSIONS AND LIMITATIONS:

This Limited Warranty applies only to the new products manufactured by or for Philips that can be identified by the trademark, trade name, or logo affixed to it. This Limited Warranty does not apply to any non-Philips hardware product or any software, even if packaged or sold with the product. Non-Philips manufacturers, suppliers, or publishers may provide a separate warranty for their own products packaged with the bundled product.

Philips is not liable for any damage to or loss of any programs, data, or other information stored on any media contained within the product, or any non-Philips product or part not covered by this warranty. Recovery or reinstallation of programs, data or other information is not covered under this Limited Warranty.

This warranty does not apply (a) to damage caused by accident, abuse, misuse, neglect, misapplication, or non-Philips product, (b) to damage caused by service performed by anyone other than Philips or Philips Authorized Service Location, (c) to a product or a part that has been modified without the written permission of

Philips, or (d) if any Philips serial number has been removed or defaced, or (e) product, accessories or consumables sold "AS IS" without warranty of any kind by including refurbished Philips product sold "AS IS" by some retailers.

This Limited Warranty does not cover:

- Shipping charges to return defective product to Philips.
- Labor charges for installation or setup of the product, adjustment of customer controls on the product, and installation or repair of antenna/signal source systems outside of the product.
- Product repair and/or part replacement because of improper installation or maintenance, connections to improper voltage supply, power line surge, lightning damage, retained images or screen markings resulting from viewing fixed stationary content for extended periods, product cosmetic appearance items due to normal wear and tear, unauthorized repair or other cause not within the control of Philips.
- Damage or claims for products not being available for use, or for lost data or lost software.
- Damage from mishandled shipments or transit accidents when returning product to Philips.
- A product that requires modification or adaptation to enable it to operate in any country other than the country for which it was designed, manufactured, approved and/or authorized, or repair of products damaged by these modifications.
- A product used for commercial or institutional purposes (including but not limited to rental purposes).
- Product lost in shipment and no signature verification receipt can be provided.
- Failure to operate per Owner's Manual.

TO OBTAIN ASSISTANCE IN THE U.S.A., PUERTO RICO, OR U.S. VIRGIN ISLANDS...

Contact Philips Customer Care Center at:
1-888-PHILIPS (1-888-744-5477)

TO OBTAIN ASSISTANCE IN CANADA...

1-800-661-6162 (French Speaking)
1-888-PHILIPS (1-888-744-5477) - (English or Spanish Speaking)

REPAIR OR REPLACEMENT AS PROVIDED UNDER THIS WARRANTY IS THE EXCLUSIVE REMEDY FOR THE CONSUMER. PHILIPS SHALL NOT BE LIABLE FOR ANY INCIDENTAL OR CONSEQUENTIAL DAMAGES FOR BREACH OF ANY EXPRESS OR IMPLIED WARRANTY ON THIS PRODUCT, EXCEPT TO THE EXTENT PROHIBITED BY APPLICABLE LAW. ANY IMPLIED WARRANTY OF MERCHANTABILITY OR FITNESS FOR A PARTICULAR PURPOSE ON THIS PRODUCT IS LIMITED IN DURATION TO THE DURATION OF THIS WARRANTY.

Some states do not allow the exclusions or limitation of incidental or consequential damages, or allow limitations on how long an implied warranty lasts, so the above limitations or exclusions may not apply to you.

This warranty gives you specific legal rights. You may have other rights which vary from state/province to state/province.

Philips, P.O. Box 671539, Marietta, GA. 30006-0026

3121 233 48802

Contents

1 Important	6
Important safety instructions	6
Notice	7
Disposal of old equipment and Used batteries	8
2 Your Soundbar System	10
Introduction	10
What's in the box	10
Overview of the main unit	11
Overview of the remote control	12
3 Get started	15
Attach speakers to the main unit	15
Attach the stand	15
Connect AV devices	16
Option 1: Connect this soundbar to devices through the TV	16
Option 2: Connect devices through this soundbar to the TV (basic)	17
Option 3: Connect devices through this soundbar to the TV (advanced)	18
Connect FM antenna	19
Connect power	19
Install remote control batteries	20
Set clock	20
Turn on	21
Switch to standby mode	21
Set up wireless connection manually	21
4 Play	22
Play an AV source through this soundbar	22
Play from USB	22
5 Control USB play	23
Skip to a track	23
Pause/resume play	23
Search within a track	23
Repeat play	23
Random play	23
Program tracks	23

6 Adjust volume level and sound effect	24
Adjust volume level	24
Adjust subwoofer volume	24
Select a sound effect	24
Select a game sound effect	24
Select a movie sound effect	24
Select a music mode (for USB only)	24
Mute sound	24
7 Tune to FM radio stations	25
Program radio stations automatically	25
Program radio stations manually	25
Tune to a preset radio station	25
8 Use more of your soundbar	26
Program remote control	26
Rename an AV source	26
Enable/disable automatic on/standby	26
Set the alarm timer	27
Set the sleep timer	27
9 Product information	28
Product information	28
Specifications	28
Amplifier	28
Tuner (FM)	28
L/R speakers	28
Subwoofer	28
General information	28
USB playability information	28
10 Troubleshooting	30
11 Appendix	31
Mount to a wall	31
What's in the supplied mounting kit	31
What else you'll need	31
Mount the main unit and speakers	31

1 Important

Important safety instructions

Know these safety symbols



This 'bolt of lightning' indicates uninsulated material within your unit may cause an electrical shock. For the safety of everyone in your household, please do not remove product covering.

The 'exclamation point' calls attention to features for which you should read the enclosed literature closely to prevent operating and maintenance problems.

WARNING: To reduce the risk of fire or electric shock, this apparatus should not be exposed to rain or moisture and objects filled with liquids, such as vases, should not be placed on this apparatus.

CAUTION: To prevent electric shock, match wide blade of plug to wide slot, fully insert.

- ① Read these instructions.
- ② Keep these instructions.
- ③ Heed all warnings.
- ④ Follow all instructions.

- ⑤ Do not use this apparatus near water.
- ⑥ Clean only with dry cloth.
- ⑦ Do not block any ventilation openings. Install in accordance with the manufacturer's instructions.
- ⑧ Do not install near any heat sources such as radiators, heat registers, stoves, or other apparatus (including amplifiers) that produce heat.
- ⑨ For countries with a polarized mains, do not defeat the safety purpose of the polarized or grounding-type plug. A polarized plug has two blades with one wider than the other. A grounding type plug has two blades and a third grounding prong. The wide blade or the third prong are provided for your safety. If the provided plug does not fit into your outlet, consult an electrician for replacement of the obsolete outlet. **Caution:** To prevent electric shock, match the wide blade of the plug to the wide slot, fully insert.

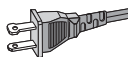

- ⑩ Protect the power cord from being walked on or pinched, particularly at plugs, convenience receptacles, and the point where they exit from the apparatus.
- ⑪ Only use attachments/accessories specified by the manufacturer.
- ⑫ Use only with the cart, stand, tripod, bracket, or table specified by the manufacturer or sold with the apparatus. When a cart is used, use caution when moving the cart/apparatus combination to avoid injury from tip-over.



- ⑬ Unplug this apparatus during lightning storms or when unused for long periods of time.
- ⑭ Refer all servicing to qualified service personnel. Servicing is required when the apparatus has been damaged in any way, such as power-supply cord or plug is damaged, liquid has been spilled or objects have fallen into the apparatus, the apparatus has been exposed to rain or moisture, does not operate normally, or has been dropped.
- ⑮ Battery usage CAUTION – To prevent battery leakage which may result in bodily injury, property damage, or damage to the unit:
 - Install all batteries correctly, + and - as marked on the unit.
 - Do not mix batteries (old and new or carbon and alkaline, etc.).
 - Remove batteries when the unit is not used for a long time.
- ⑯ Apparatus shall not be exposed to dripping or splashing.
- ⑰ Do not place any sources of danger on the apparatus (e.g. liquid filled objects, lighted candles).
- ⑱ This product may contain lead and mercury. Disposal of these materials may be regulated due to environmental considerations. For disposal or recycling information, please contact your local authorities or the Electronic Industries Alliance: www.eiae.org.



Warning

- Never remove the casing of this soundbar.
- Never lubricate any part of this soundbar.
- Never place this soundbar on other electrical equipment.
- Keep this soundbar away from direct sunlight, naked flames or heat.
- Never look into the laser beam inside the soundbar.
- Ensure that you always have easy access to the power cord, plug or adaptor to disconnect the soundbar from the power.

- ① **Wall or Ceiling Mounting - The appliance should be mounted to a wall or ceiling only as recommended by the manufacturer.**

Wall mounting of the soundbar should only be performed by qualified personnel. The soundbar must only be mounted on an appropriate wall bracket and on a wall that can safely hold the weight of the soundbar. Improper wall mounting can result in severe injury or damage. Do not attempt to wall mount the soundbar yourself.

Notice

Notice of compliance

For USA:

This equipment has been tested and found to comply with the limits for a Class B digital device, pursuant to Part 15 of the FCC Rules. These limits are designed to provide reasonable protection against harmful interference in a residential installation. This equipment generates, uses and can radiate radio frequency energy and, if not installed and used in accordance with the instructions, may cause harmful interference to radio communications. However, there is no guarantee that interference will not occur in a particular installation. If this equipment does cause harmful interference to radio or television reception, which can be determined by turning the equipment off and on, the user is encouraged to try to correct the interference by one or more of the following measures:

- Reorient or relocate the receiving antenna.

- Increase the separation between the equipment and receiver.
- Connect the equipment into an outlet on a circuit different from that to which the receiver is connected.
- Consult the dealer or an experienced radio/TV technician for help.

For Canada:

This digital apparatus does not exceed the Class B limits for radio noise emissions from digital apparatus as set out in the Radio Interference Regulations of the Canadian Department of Communications. This Class B digital apparatus complies with Canadian ICES-003.

The set complies with the FCC-Rules, Part 15. Operation is subject to the following two conditions:

1. This device may not cause harmful interference, and
2. This device must accept any interference received, including interference that may cause undesired operation.

FCC Declaration of conformity

Model number: PHILIPS BTM630/37

Trade Name: Philips

Responsible Party:

Philips Consumer Electronics

P.O. Box 671539

Marietta, GA 30006-0026

1-800-PHILIPS (744-5477)

Any changes or modifications made to this device that are not expressly approved by Philips Consumer Electronics may void the user's authority to operate the equipment. Manufactured under license from Dolby Laboratories. 'Dolby', 'Pro Logic' and the double D symbol  are trademarks of Dolby Laboratories.

Disposal of old equipment and Used batteries

Information for Users on Collection and Disposal of Old Equipment and Used Batteries



 Pb, Hg, Cd

These symbols on the products, batteries, packaging, and/or accompanying documents mean that used electrical and electronic products and batteries should not be mixed with general household waste. For proper treatment, recovery and recycling of old products and used batteries, please take them to applicable collection points, in accordance with your national legislation and the Directives 2002/96/EC and 2006/66/EC.

By disposing of these products and batteries correctly, you will help to save valuable resources and prevent any potential negative effects on human health and the environment which could otherwise arise from inappropriate waste handling.

For more information about collection and recycling of old products and batteries, please contact your local municipality, your waste disposal service or the point of sale where you purchased the items.

Information on Disposal in other Countries outside the European Union

These symbols are only valid in the European Union. If you wish to discard these items, please contact your local authorities or dealer and ask for the correct method of disposal.

Note for the battery symbol



Pb, Hg, Cd

This symbol might be used in combination with a chemical symbol. In this case it complies with the requirement set by the Directive for the chemical involved.

Environmental information

All redundant packing material has been omitted. We have done our utmost to make the packaging easily separable into mono materials. Please observe the local regulations regarding the disposal of packing materials.

2 Your Soundbar System

Congratulations on your purchase, and welcome to Philips! To fully benefit from the support that Philips offers, register your product at www.Philips.com/welcome.

Introduction

Your soundbar provides superb sound performance when you watch TV, DVDs, listen to music, or play games.

You can control all connected audio/video devices easily with the programmable smart remote control.

The wireless subwoofer makes setup simple, too - there are no messy cables to connect.

What's in the box

Check and identify the contents of your package:

- Main unit
- Speakers (x 2)
- Digital wireless subwoofer
- Smart remote control (with battery)
- AC power adaptor for main unit
- Studs (x2) used to attach speakers to main unit
- Table stand
- Wall mount bracket and screws (x4)
- FM antenna
- AV cable
- Coaxial cable
- Composite cable

Overview of the main unit

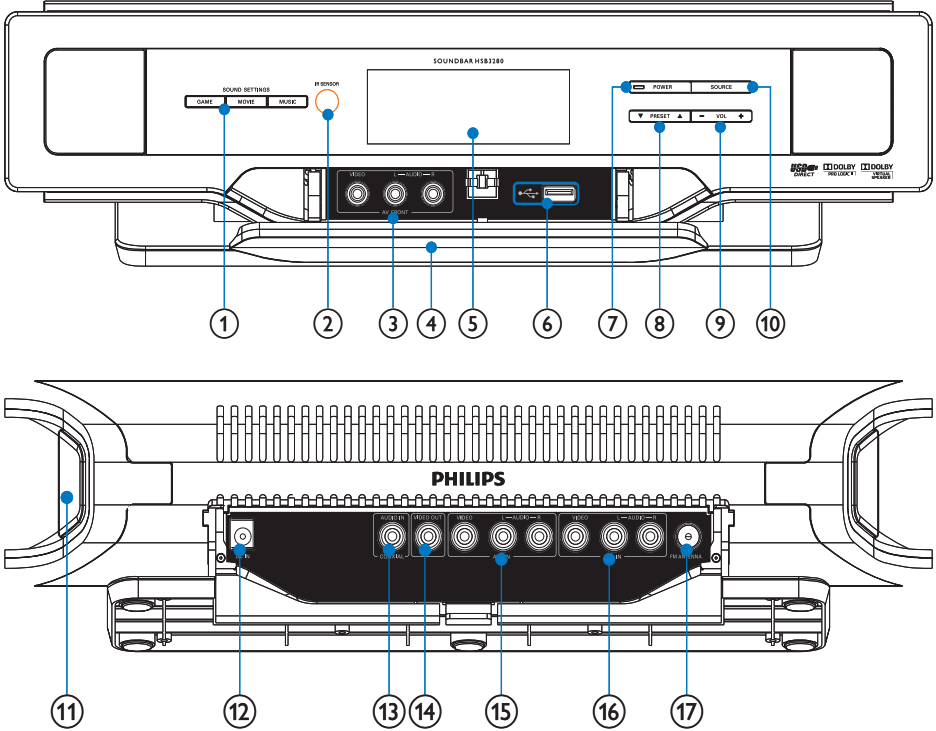

- ① **SOUND SETTINGS (GAMES, MOVIE, MUSIC)**
 - Select a sound effect.
- ② **IR sensor**
- ③ **AV FRONT (VIDEO L-AUDIO-R)**
 - AV input sockets on the front panel.
- ④ **Flip cover**
- ⑤ **Display panel**
 - Show current status.
- ⑥ **USB**
 - Socket for a USB mass storage device.
- ⑦ **POWER**
 - Turn on the soundbar; switch to standby mode, or switch to Eco Power Standby.
- ⑧ **PRESET/▲▼**
 - Select a preset FM radio station.
 - Select an album/folder in a connected USB device.
- ⑨ **-VOL +**
 - Adjust volume.
 - Adjust time.
- ⑩ **SOURCE**
 - Select a source for play: TUNER, USB, AV1, AV2, AV FRONT or COAX.
 - Enable/disable automatic on/standby.
- ⑪ **PRESS**
 - Detach speakers from the main unit.
- ⑫ **DC IN**
 - Connect the AC adaptor.

⑬ **AUDIO IN - COAXIAL**

- Coaxial audio output socket.

⑭ **VIDEO OUT**

- Socket for composite video output.

⑮ **AV2 IN (VIDEO L - AUDIO - R)**

- AV input sockets.

⑯ **AV1 IN (VIDEO L - AUDIO - R)**

- AV input sockets.

⑰ **FM ANTENNA**

- Connect the FM antenna.

Overview of the remote control

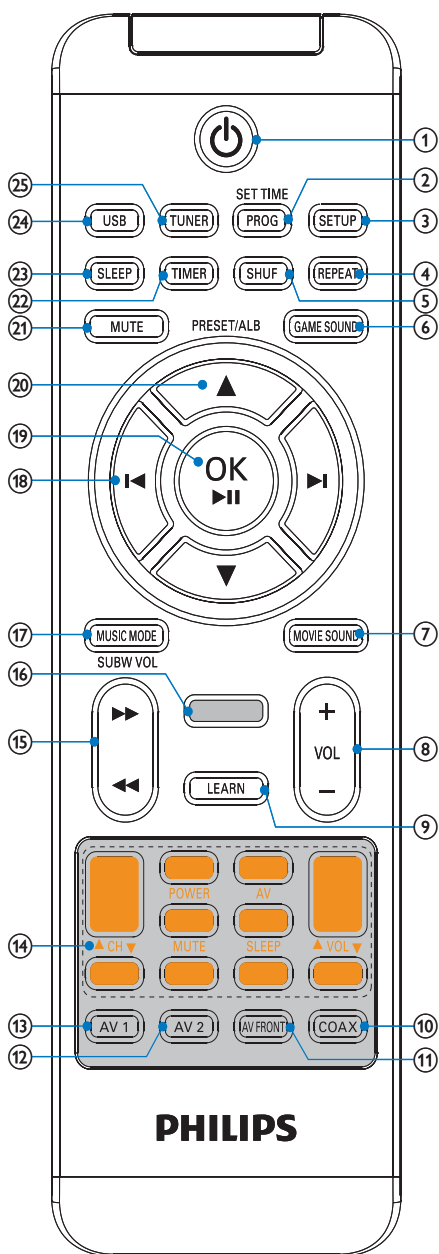

- ① **Power**
 - Turn on the soundbar, switch to standby mode, or switch to Eco Power Standby.
- ② **SET TIME/PROG**
 - Set the clock.
 - Program tracks in a USB device.
 - Program radio stations.
- ③ **SETUP**
 - Rename AV resource.
- ④ **REPEAT**
 - Select a repeat play mode for the connected USB device.
- ⑤ **SHUF**
 - Play tracks in the USB device randomly.
- ⑥ **GAME SOUND**
 - Select a game sound setting.
- ⑦ **MOVIE SOUND**
 - Select a movie sound setting.
- ⑧ **VOL + / -**
 - Adjust volume.
 - Adjust time.
- ⑨ **LEARN**
 - Program remote control.
- ⑩ **COAX**
 - Select the AV input source from the **AUDIO IN - COAXIAL** socket.
- ⑪ **AV FRONT**
 - Select the AV source input from the **AV FRONT (VIDEO L-AUDIO-R)** sockets.
- ⑫ **AV2**
 - Select the AV source input from the **AV2 IN (VIDEO L - AUDIO - R)** sockets.
- ⑬ **AV1**
 - Select the AV source input from the **AV1 IN (VIDEO L - AUDIO - R)** sockets.

⑭ **Programing buttons**

- Are reserved for remote control programing.

⑮ **◀◀▶▶**

- Fast reverse or fast forward within a track in the USB device.
- Tune to a radio station.

⑯ **Indicator for remote control programing**

⑰ **MUSIC MODE/SUBW VOL**

- In AV1, AV2, AV FRONT or COAXIAL mode, select a music sound setting.
- In USB mode, adjust subwoofer volume.

⑱ **◀▶**

- Skip to the previous/next track in the USB device.

⑲ **OK / ▶▶▶**

- Start or pause USB play.
- Confirm renaming of an AV source.

⑳ **PRESET/ALB/▲▼**

- Skip to the previous/next album (folder) in the USB device.
- Select a preset radio station.

㉑ **MUTE**

- Mutes volume.

㉒ **TIMER**

- Set the alarm timer.

㉓ **SLEEP**

- Set the sleep timer.

㉔ **USB**

- Select the USB source.

㉕ **TUNER**

- Select the tuner (FM) source.

3 Get started

Caution

- Use the controls only as stated in this user manual.

Always follow the instructions in this chapter in sequence.

If you contact Philips, you will be asked for the model and serial numbers. Find the model number and serial number of this soundbar at the back or the bottom of your soundbar. Write these numbers here:

Model No. _____

Serial No. _____

Attach speakers to the main unit

- 1 Place the main unit on a soft and flat surface.
 - Ensure that the bottom side faces upwards.

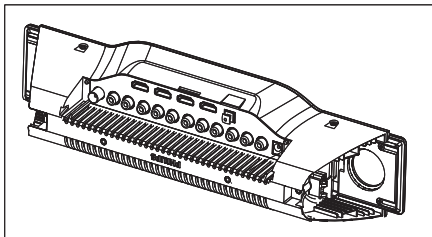

- 2 Attach the left speaker to the left side of the main unit.

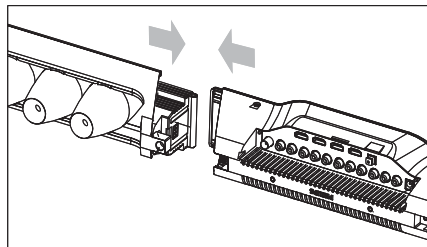

- 3 Insert a supplied stud into the hole.

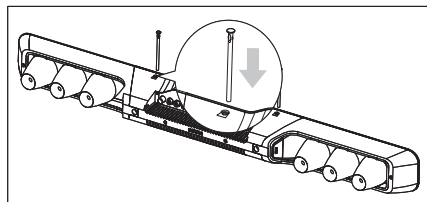

- 4 Repeat steps 2 and 3 to attach the right speaker.

Attach the stand

- 1 Slide the supplied table stand onto the bottom of the main unit until you hear a click.

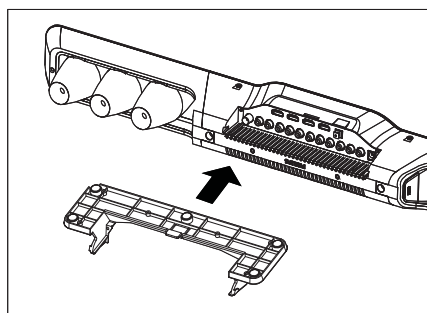

 Tip

- You can also mount the soundbar on a wall (see 'Appendix' on page 29).

Connect AV devices

 Note

- There are various ways to connect the soundbar to other AV devices. You only need to select the best option that fits your existing AV device setup.
- For AV connection to the soundbar, there are multiple sets of AV sockets available on the main unit. You can choose either set for an AV connection.
- When you connect cables, ensure that the color of the plug matches the color of the socket.
- To use sockets on the front panel, flip open the cover.
- The types of AV devices and connections in the following instructions are for reference only.

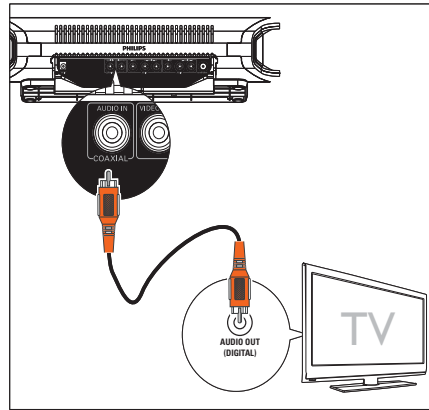

- You can also connect the red/white audio connectors of the supplied AV cable from the TV to a set of audio input sockets.

 Note

- It is unnecessary to connect the yellow video connectors.

Option 1: Connect this soundbar to devices through the TV

If all the devices for use are connected to the TV and the TV has an available audio output socket, follow these instructions.

- 1 If the TV has a digital output socket, connect the supplied coaxial cable (orange) from the TV to the **AUDIO IN - COAXIAL** socket.

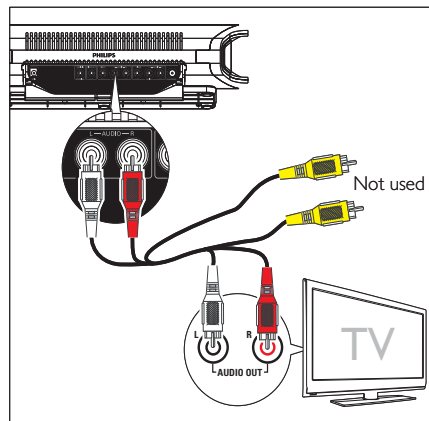

Option 2: Connect devices through this soundbar to the TV (basic)

If the TV does not have an available audio output socket, follow these instructions.

- 1 Connect the video input socket on the TV to the **VIDEO OUT** socket.

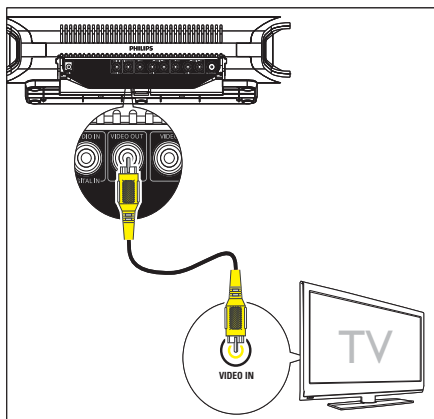

- 2 Connect the AV devices directly to the soundbar:

- A Game console:
Connect the AV output sockets on the game console to the **AV FRONT (VIDEO L-AUDIO-R)** sockets.

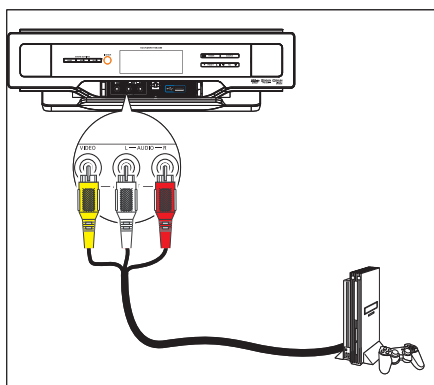

- B Set top box

Connect the AV output sockets the set top box to the **AV1 IN (VIDEO L - AUDIO - R)** sockets.

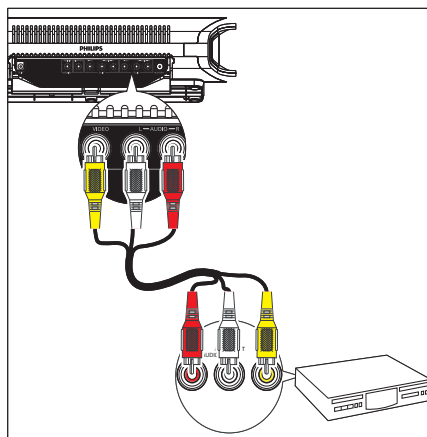

- C DVD player

Connect the AV output sockets on the DVD player to the **AV2 IN (VIDEO L - AUDIO - R)** sockets.

