



No.198 Kezhu Road, Science Town Economic& Technology  
Development District Guangzhou, China 510663 Telephone:

Telephone: +86 (0) 20 82155555

Fax: +86 (0) 20 82075059

Email: [sgs\\_internet\\_operations@sgs.com](mailto:sgs_internet_operations@sgs.com)

Report No.: GLEMR070501389RFF

Page: 1 of 53

## TEST REPORT

**Application No. :** GLEMR070501389RF  
**Applicant:** Philips Consumer Electronics Company  
**Manufacturer:** Philips Electronics HK Ltd.  
**Factory** Arts Electronics Co., Ltd.  
**FCC ID:** BOU-BTM630V37  
**Fundamental Carrier  
Frequency :** 2.402GHz to 2.480GHz  
**Equipment Under Test (EUT):**  
**Name:** Bluetooth Micro System  
**Model No.:** BTM630/37  
**Standards:** FCC PART 15, SUBPART C: 2006 (Section 15.247);  
FCC PART 15, SUBPART B: 2006.  
**Date of Receipt:** 18 May 2007  
**Date of Test:** 18 May to 7 June 2007  
**Date of Issue:** 7 June 2007

<b>Test Result :</b>	<b>PASS *</b>
----------------------	---------------

\* In the configuration tested, the EUT detailed in this report complied with the standards specified above. Please refer to section 2 of this report for further details.

Authorized Signature:

Stephen Guo  
Manager

This report refers to the General Conditions for Inspection and Testing Services, printed overleaf  
This report details the results of the testing carried out on one sample. The results contained in this test report do not relate to other samples of the same product. The manufacturer should ensure that all products in series production are in conformity with the product sample detailed in this report.

This report may only be reproduced and distributed in full. If the product in this report is used in any configuration other than that detailed in the report, the manufacturer must ensure the new system complies with all relevant standards. Any mention of SGS International Electrical Approvals or testing done by SGS International Electrical Approvals in connection with, distribution or use of the product described in this report must be approved by SGS International Electrical Approvals in writing.



## 2 Test Summary

For Bluetooth Function:			
Test	Test Requirement	Standard Paragraph	Result
Maximum Peak Output Power	FCC PART 15 :2006	Section 15.247(b)(1)	PASS
Conducted Emission	FCC PART 15 :2006	Section 15.207 &15.107	PASS
Antenna Power (30MHz to 1GHz)	FCC PART 15 :2006	ANSI C63.4 : 2003 & 15.111	PASS
Conducted Spurious Emission (30MHz to 25GHz)	FCC PART 15 :2006	Section 15.209 &15.247(d)	PASS
Radiated Spurious Emission (30MHz to 25GHz)	FCC PART 15 :2006	Section 15.209 &15.247(d) &15.109	PASS
Band Edges Measurement	FCC PART 15 :2006	Section 15.247 (d) &15.205	PASS
Hopping Channel Number	FCC PART 15 :2006	Section 15.247(a)(1)(iii)	PASS
Carrier Frequencies Separated	FCC PART 15 :2006	Section 15.247(a)(1)	PASS
Dwell Time	FCC PART 15 :2006	Section 15.247(a)(1)(iii)	PASS
Antenna Requirement	FCC PART 15 :2006	Section 15.247 (c)	PASS

Remark: The EUT passed the Radiated Emission test after modifications carried out by applicant.



### 3 Contents

	Page
<b>1 COVER PAGE</b> .....	<b>1</b>
<b>2 TEST SUMMARY</b> .....	<b>2</b>
<b>3 CONTENTS</b> .....	<b>3</b>
<b>4 GENERAL INFORMATION</b> .....	<b>4</b>
4.1 CLIENT INFORMATION.....	4
4.2 GENERAL DESCRIPTION OF E.U.T. ....	4
4.3 DESCRIPTION OF SUPPORT UNITS .....	4
4.4 STANDARDS APPLICABLE FOR TESTING.....	4
4.5 TEST LOCATION.....	4
4.6 OTHER INFORMATION REQUESTED BY THE CUSTOMER .....	4
4.7 TEST FACILITY .....	5
<b>5 EQUIPMENTS USED DURING TEST</b> .....	<b>6</b>
<b>6 TEST RESULTS</b> .....	<b>7</b>
6.1 E.U.T. OPERATION .....	7
6.2 MAXIMUM PEAK OUTPUT POWER .....	7
6.3 CONDUCTED EMISSIONS MAINS TERMINALS, 150KHZ TO 30MHZ.....	10
6.4 ANTENNA POWER, 30MHZ TO 1GHZ .....	13
6.4.1 <i>E.U.T. Operation</i> .....	13
6.4.2 <i>Measurement Data</i> .....	13
6.5 CONDUCTED SPURIOUS EMISSIONS.....	14
6.6 RADIATED SPURIOUS EMISSIONS.....	19
6.6.1 <i>Radiated Emissions, 30MHz to 1GHz</i> .....	26
6.6.2 <i>E.U.T. Operation</i> .....	26
6.6.3 <i>Measurement Data</i> .....	26
6.6.4 <i>Radiated Emissions which fall in the restricted bands</i> .....	37
6.7 BAND EDGES REQUIREMENT .....	40
6.7.1 <i>100 kHz Bandwidth Outside the Frequency Band</i> .....	40
6.8 HOPPING CHANNEL NUMBER.....	41
6.9 OCCUPIED BANDWIDTH.....	42
6.10 CARRIER FREQUENCIES SEPARATED .....	44
6.11 DWELL TIME .....	47
6.12 ANTENNA REQUIREMENT.....	53
6.12.1 <i>Standard Applicable</i> .....	53
6.12.2 <i>Antenna Construction</i> .....	53



## 4 General Information

### 4.1 Client Information

Applicant:	Philips Consumer Electronics Company
Address of Applicant:	3029 East Governor John Sevier Hwy, Knoxville, Tennessee, United States
Manufacturer:	Philips Electronics HK Ltd.
Address of Manufacturer:	5/F., Hong Kong Science Park, 5 Science Park East Avenue, Shatin, N.T., Hong Kong.
Factory:	Arts Electronics Co., Ltd.
Address of Factory:	NO. 1, SHANGXING LU, SHANGJIAO COMMUNITY, CHANGAN TOWN, DONGGUAN CITY, GUANGDONG PROVINCE, CHINA.

### 4.2 General Description of E.U.T.

Name:	Bluetooth Micro System
Model No.:	BTM630/37
Number of Channels	79 Channels
Channel Separation	1 MHz
Type of Modulation	FHSS (Frequency Hopping Spread Spectrum)
Dwell time	Per channel is less than 0.4S.
Antenna Type	Integral
Power Supply:	AC 120V / DC 15V
Adapter information	Model: GFP451-1530BX-1, Input: 100-240V~50/60Hz, Output: 15V, 3A
Functions:	CD player with i-Pod docket, FM receiver and Bluetooth function.

### 4.3 Description of Support Units

The EUT has been tested independently or connecting with Bluetooth cell phone (SonyEricsson K618i) and i-Pod (Model: Mini, 4GB).

### 4.4 Standards Applicable for Testing

The customer requested FCC tests for the EUT.

The standard used was FCC PART 15, SUBPART C: 2006 (Section 15.247);  
FCC PART 15, SUBPART B: 2006.

### 4.5 Test Location

All tests were performed at:

SGS-CSTC Standards Technical Services Co., Ltd., Guangzhou EMC Laboratory, No.198 Kezhu Road, Science Town Economic & Technology Development District Guangzhou, China 510663

Tel: +86 20 82155555 Fax: +86 20 82075059

No tests were sub-contracted.

### 4.6 Other Information Requested by the Customer

None.



#### 4.7 Test Facility

The test facility is recognized, certified, or accredited by the following organizations:

- **NVLAP – Lab Code: 200611-0**

SGS-CSTC Standards Technical Services Co., Ltd., Guangzhou EMC Laboratory is recognized under the National Voluntary Laboratory Accreditation Program (NVLAP/NIST). NVLAP Code: 200611-0.

- **CNAS L0167**

SGS-CSTC Standards Technical Services Co., Ltd., EMC Laboratory has been assessed and in compliance with CNAS-CL01:2006 accreditation criteria for testing laboratories (identical to ISO/IEC 17025:2005 General Requirements) for the Competence of Testing Laboratories.

- **FCC – Registration No.: 282399**

SGS-CSTC Standards Technical Services Co., Ltd., EMC Laboratory has been registered and fully described in a report filed with the (FCC) Federal Communications Commission. The acceptance letter from the FCC is maintained in our files. Registration 282399, May 31, 2002. With the above and NVLAP's accreditation, SGS-CSTC is an authorized test laboratory for the DoC process.

- **Industry Canada (IC)**

The 3m/10m Alternate Semi-anechoic chamber of SGS-CSTC Standards Technical Services Co., Ltd. has been registered by Certification and Engineering Bureau of Industry Canada for radio equipment testing with Registration No.: 4620B-1.

Date of Registration: Jan 15, 2007. Valid until Jan 15, 2009



## 5 Equipments Used during Test

RE in Chamber/OATS						
No:	Test Equipment	Manufacturer	Model No.	Serial No.	Cal. Date (dd-mm-yy)	Cal.Due date (dd-mm-yy)
EMC0525	Compact Semi-Anechoic Chamber	ChangZhou ZhongYu	N/A	N/A	06-03-2007	06-03-2008
EMC0522	EMI Test Receiver	Rohde & Schwarz	ESIB26	100249	05-12-2006	05-12-2007
N/A	EMI Test Software	Audix	E3	N/A	N/A	N/A
EMC0514	Coaxial cable	SGS	N/A	N/A	04-12-2006	04-12-2007
EMC0524	Bi-log Type Antenna	Schaffner -Chase	CBL6112B	2966	31-10-2006	31-10-2007
EMC0519	Bilog Type Antenna	Schaffner -Chase	CBL6143	5070	31-07-2006	31-07-2007
EMC0517	Horn Antenna	Rohde & Schwarz	HF906	100095	29-07-2006	29-07-2007
EMC0040	Spectrum Analyzer	Rohde & Schwarz	FSP30	100324	05-12-2006	05-12-2007
EMC0520	0.1-1300 MHz Pre-Amplifier	HP	8447D OPT 010	2944A06252	28-03-2007	28-03-2008
EMC0521	1-26.5 GHz Pre-Amplifier	Agilent	8449B	3008A01649	28-03-2007	28-03-2008
EMC0523	Active Loop Antenna	EMCO	6502	00042963	09-08-2006	09-08-2008
EMC0530	10m Semi-Anechoic Chamber	ETS	N/A	N/A	22-08-2006	22-08-2007

General used equipment						
No:	Test Equipment	Manufacturer	Model No.	Serial No.	Cal. Date (dd-mm-yy)	Cal.Due date (dd-mm-yy)
EMC0050-EMC0053	Temperature, & Humidity	ZHENGZHOU BO YANG	WSB	N/A	05-12-2006	05-12-2007
EMC0054	Temperature, & Humidity	Shenzhen Tai Kong	THG-1	N/A	04-01-2007	04-01-2008
EMC0006	DMM	Fluke	73	70681569	27-09-2006	27-09-2007
EMC0007	DMM	Fluke	73	70671122	27-09-2006	27-09-2007

Conducted Emission						
No:	Test Equipment	Manufacturer	Model No.	Serial No.	Cal. Date (dd-mm-yy)	Cal.Due date (dd-mm-yy)
EMC0306	Shielding Room	Zhong Yu	8 x 3 x 3.8 m <sup>3</sup>	N/A	N/A	N/A
EMC0102	LISN	Schaffner Chase	MNZ050D/1	1421	05-12-2006	05-12-2007
EMC0506	EMI Test Receiver	Rohde & Schwarz	ESCS30	100085	05-12-2006	05-12-2007
EMC0107	Coaxial Cable	SGS	2m	N/A	25-11-2006	25-11-2007
EMC0106	Voltage Probe	SGS	N/A	N/A	N/A	N/A

## 6 Test Results

### 6.1 E.U.T. Operation

Input voltage: AC 120V

Type of antenna: Integral

Operating Environment:

Temperature: 20.0 -25.0 °C

Humidity: 38-48 % RH

Atmospheric Pressure: 992 -1006 mbar

EUT Operation: Test the EUT as a product which has frequency hopping system. The total hopping channels are 79 channels (0 to 78 channels), the fundamental frequencies are from 2.402GHz to 2.480GHz.

Test the EUT to transmit and receive data at lowest (**Channel 0: 2.402GHz**), middle (**Channel 39: 2.441GHz**), and highest channel (**Channel 78: 2.480GHz**), frequencies individually for the compliance test.

### 6.2 Maximum Peak Output Power

Test Requirement: FCC Part15 C

Test Method: Base on ANSI 63.4.

Test Date: 18 May 2007

Test Limit:

Regulation 15.247 (b)(1)For frequency hopping systems operating in the 2400-2483.5 MHz band employing at least 75 non-overlapping hopping channels, and all frequency hopping systems in the 5725-5850 MHz band: 1 watt. For all other frequency hopping systems in the 2400-2483.5 MHz band: 0.125 watts.

The non-overlapping hopping channels of EUT over 75, the result refer to the result "Hopping channel number" of this document. So 1 watt limit applies.

Test mode: Test in transmitting mode: Channel 0, Channel 39, Channel 78.

Test Configuration:

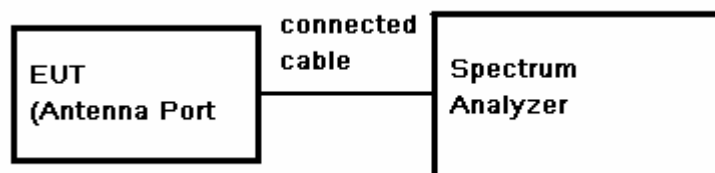



Test Procedure:

1. Remove the antenna from the EUT and then connect a low RF cable from the antenna port to the spectrum.
2. Set the spectrum analyzer: RBW = 1 MHz, VBW = 3 MHz, Sweep = auto; Detector Function = Peak.
3. Keep the EUT in transmitting at lowest, medium and highest channel individually. Record the max value.

Test Result:

Test Channel	Fundamental Frequency (GHz)	Reading Power (dBm)	Cable Loss (dB)	Output Power (dBm)	Limit (dBm)	Margin (dB)
0	2.402	1.01	0.20	1.21	30	28.79
39	2.441	1.87	0.20	2.07	30	27.93
78	2.480	0.58	0.20	0.78	30	29.22

TEST RESULTS: The unit does meet the FCC requirements.

Channel 0:

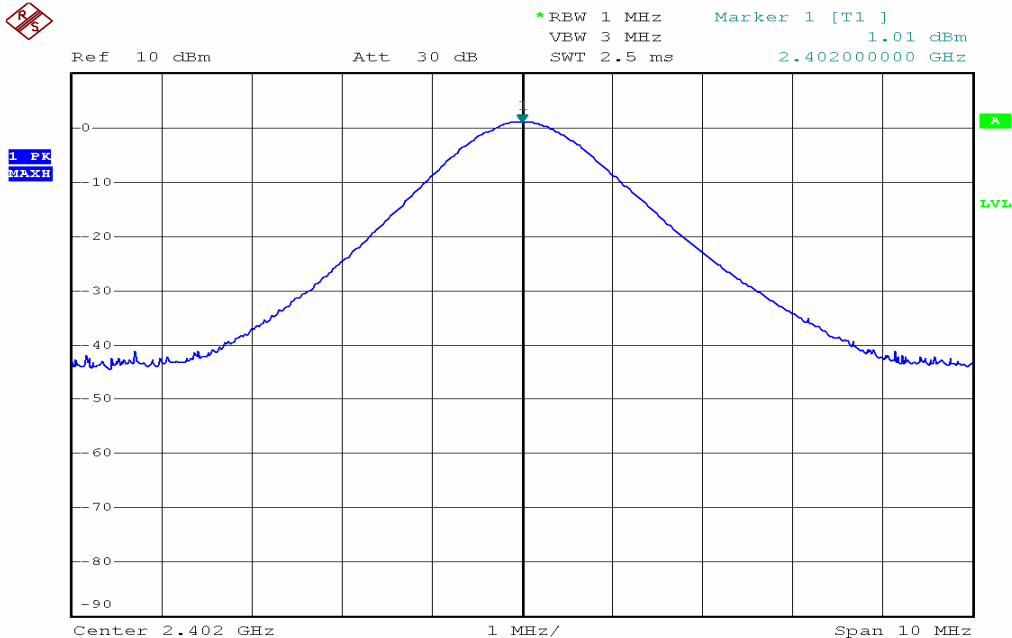

Date: 18.MAY.2007 11:50:51





Channel 39:

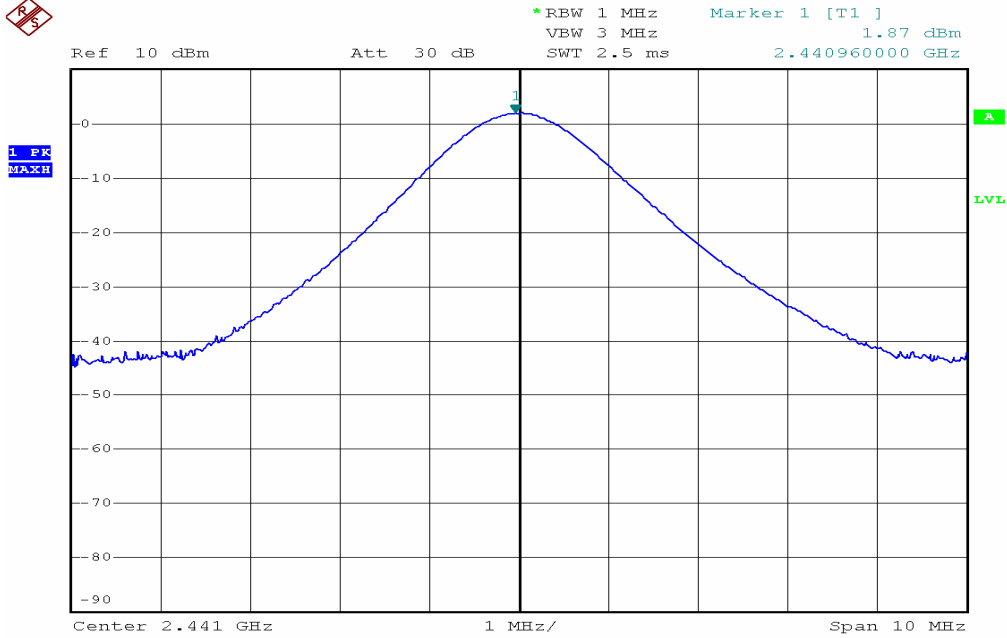

Date: 18.MAY.2007 11:51:33

Channel 78:

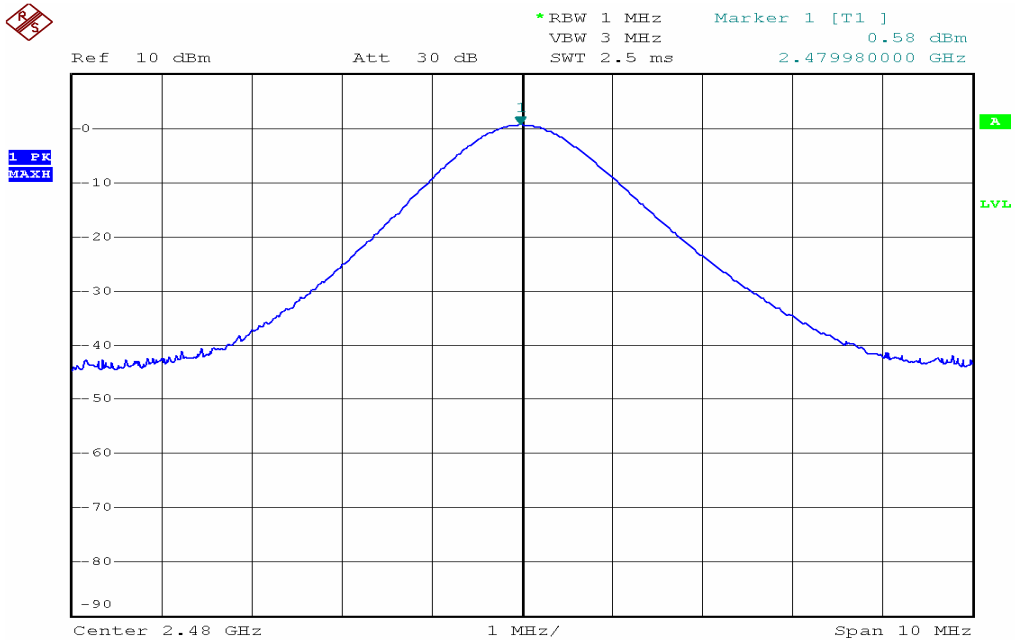

Date: 18.MAY.2007 11:52:03



### 6.3 Conducted Emissions Mains Terminals, 150kHz to 30MHz

Test Requirement: FCC Part15 B  
Test Method: ANSI C63.4  
Test Date: 25 May 2007  
Frequency Range: 150KHz to 30MHz  
Class / Severity: Class B  
Detector: Peak for pre-scan (9kHz Resolution Bandwidth)  
Quasi-Peak if maximised peak within 6dB of Quasi-Peak limit  
EUT Operation: Test the EUT in CD play mode (no worst case was found in the pre-test on all operation modes) and the Bluetooth function on.

Test result:

An initial pre-scan was performed on the live and neutral lines with peak detector.  
Quasi-Peak and Average measurement were performed at the frequencies with maximized peak emission were detected.



Live Line:

Peak Scan:

Level (dBμV)

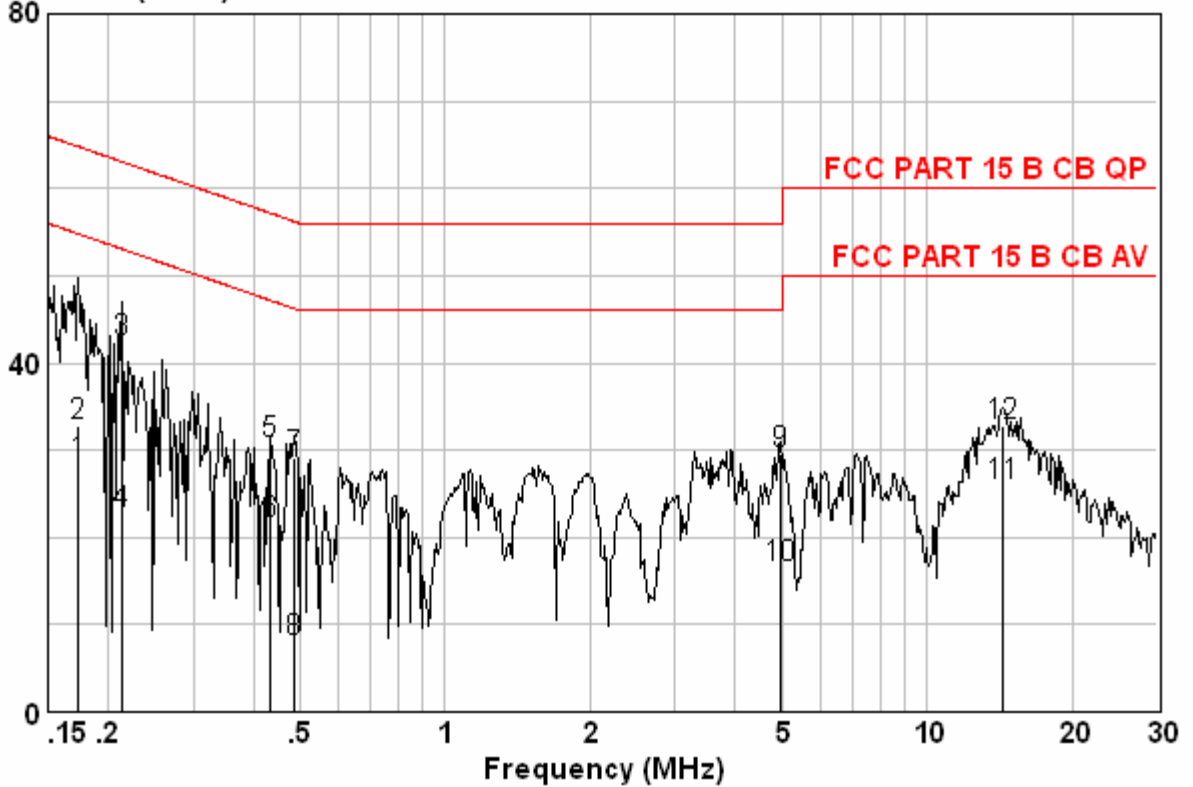

Quasi-peak and Average measurement:

Freq	Read Level	Cable Loss	LISN Factor	Level	Limit Line	Over Limit	Remark
MHz	dBμV	dB	dB	dBμV	dBμV	dB	
0.173	28.36	0.00	0.05	28.41	64.81	-36.40	QP
0.173	32.65	0.00	0.05	32.70	54.81	-22.11	AVERAGE
0.213	42.35	0.00	0.10	42.45	63.10	-20.65	QP
0.213	22.69	0.00	0.10	22.79	53.10	-30.31	AVERAGE
0.435	30.69	0.00	0.10	30.79	57.15	-26.36	QP
0.435	21.36	0.00	0.10	21.46	47.15	-25.69	AVERAGE
0.486	29.10	0.00	0.10	29.20	56.23	-27.03	QP
0.486	7.92	0.00	0.10	8.02	46.23	-38.21	AVERAGE
4.952	29.36	0.08	0.10	29.53	56.00	-26.47	QP
4.952	16.35	0.08	0.10	16.52	46.00	-29.48	AVERAGE
14.364	25.36	0.16	0.38	25.90	50.00	-24.10	AVERAGE
14.364	32.17	0.16	0.38	32.71	60.00	-27.29	QP

Neutral Line

Peak Scan:

Level (dBuV)

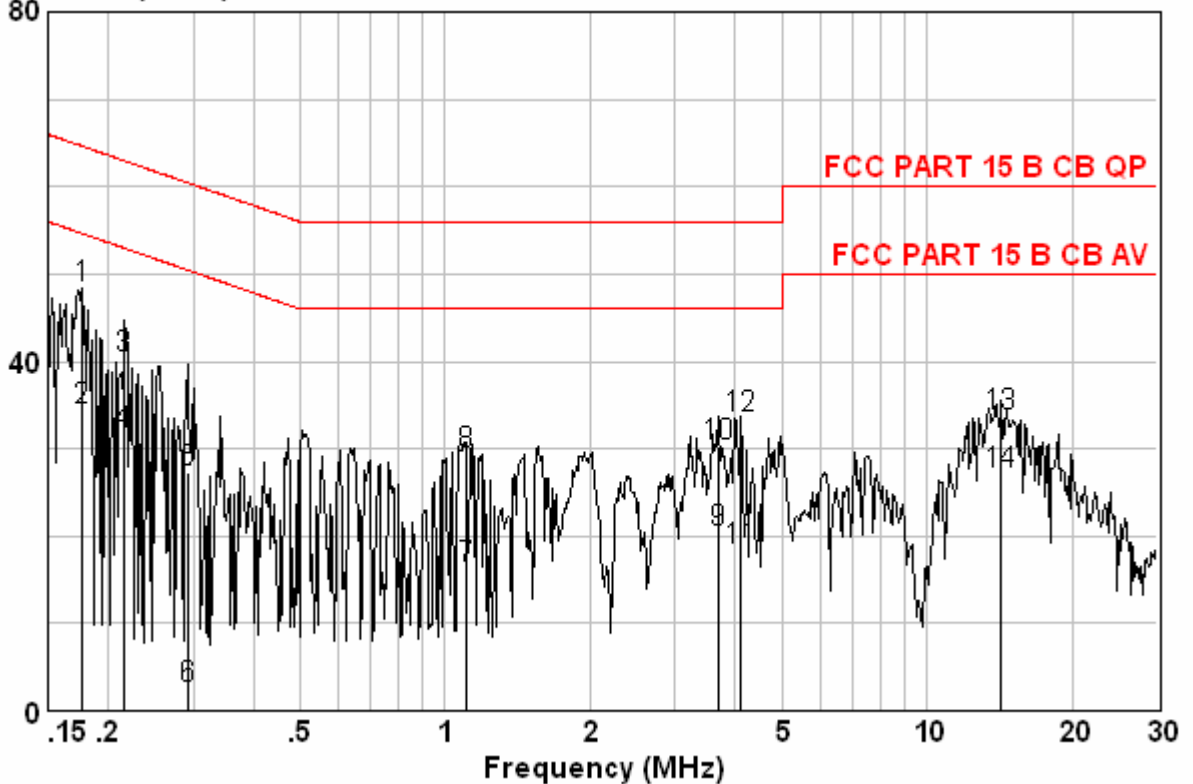

Quasi-peak and Average measurement:

Freq	Read Level	Cable Loss	LISN Factor	Level	Limit Line	Over Limit	Remark
MHz	dBuV	dB	dB	dBuV	dBuV	dB	
0.176	48.25	0.00	0.10	48.35	64.68	-16.33	QP
0.176	34.25	0.00	0.10	34.35	54.68	-20.33	AVERAGE
0.216	40.26	0.00	0.10	40.36	62.96	-22.60	QP
0.216	31.58	0.00	0.10	31.68	52.96	-21.28	AVERAGE
0.292	27.10	0.00	0.10	27.20	60.46	-33.26	QP
0.292	2.36	0.00	0.10	2.46	50.46	-48.00	AVERAGE
1.106	16.25	0.01	0.09	16.35	46.00	-29.65	AVERAGE
1.106	29.36	0.01	0.09	29.46	56.00	-26.54	QP
3.681	20.34	0.06	0.00	20.40	46.00	-25.60	AVERAGE
3.681	30.14	0.06	0.00	30.20	56.00	-25.80	QP
4.114	18.25	0.06	0.00	18.31	46.00	-27.69	AVERAGE
4.114	33.47	0.06	0.00	33.53	56.00	-22.47	QP
14.288	33.10	0.16	0.40	33.66	60.00	-26.34	QP
14.288	26.58	0.16	0.40	27.14	50.00	-22.86	AVERAGE



### 6.4 Antenna Power, 30MHz to 1GHz

Test Requirement: 15.111  
 Test Method: ANSI C63.4  
 Test Date: 25 May 2007  
 Frequency Range: 30MHz to 1GHz  
 Class / Severity: 2nW at 75ohm terminal.  
 Detector: RMS

#### 6.4.1 E.U.T. Operation

Operating Environment:

Temperature: 25.0 °C      Humidity: 52% RH      Atmospheric Pressure: 1002 mbar

EUT Operation: Test the EUT in FM Tuner Mode and adjust the frequency tuned at 87.5MHz, 98MHz, 108MHz respective, compliance test was conducted in FM tuner mode with tuned at 98MHz as no worst case was found.

#### 6.4.2 Measurement Data

Connected the antenna port to test receiver via an 70ohm/50ohm impedance matching pad.

An initial peak scan was conducted and RMS measurement was performed at the frequencies at which maximum peak value was detected.

Please refer to the following RMS measurement result for reference.

Tune at 98MHz:

Frequency (MHz)	Receiver Reading (dBμV)	Transducer (dB)	RMS (dBμV)	Limit (dBμV)	Margin (dB)
108.700	26.4	7.5	33.9	51.8	17.9
217.400	30.4	7.5	37.9	51.8	13.9
434.815	16.1	7.5	23.6	51.8	28.2
326.1154	14.9	7.5	22.4	51.8	29.4
544.600	15.3	7.5	22.8	51.8	29
652.222	21.5	7.5	29	51.8	22.8
869.630	17.2	7.5	24.7	51.8	27.1

Remark:

Effective limit voltage at 75ohm impedance:  $Ext (U^2 R) = 387.3\mu V$

Effective limit in dBμV=51.8dBμV



### 6.5 Conducted Spurious Emissions

Test Requirement: FCC Part 15 C  
Test Method: Based on FCC Part15 C Section 15.247:  
Test Date: 18 May 2007.  
Test requirements: (d) In any 100 kHz bandwidth outside the frequency band in which the spread spectrum or digitally modulated intentional radiator is operating, the radio frequency power that is produced by the intentional radiator shall be at least 20 dB below that in the 100 kHz bandwidth within the band that contains the highest level of the desired power, based on either an RF conducted or a radiated measurement, provided the transmitter demonstrates compliance with the peak conducted power limits.

#### Test Procedure:

1. Remove the antenna from the EUT and then connect a low RF cable from the antenna port to the spectrum.
2. Set the spectrum analyzer: RBW = 100KHz, VBW >= RBW(100KHz) , Sweep = auto; Detector Function = Peak (Max. hold).

**Test result: Pass**

Lowest Channel (channel 0): 30M to 1GHz

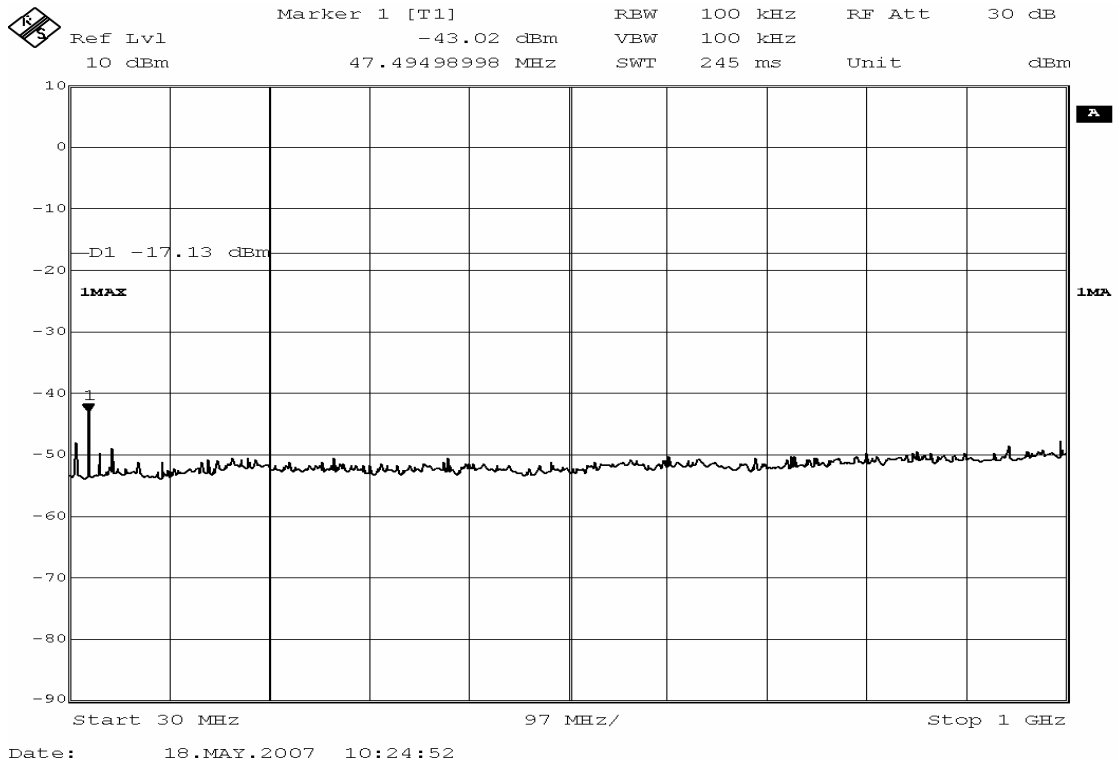



1G to 5GHz

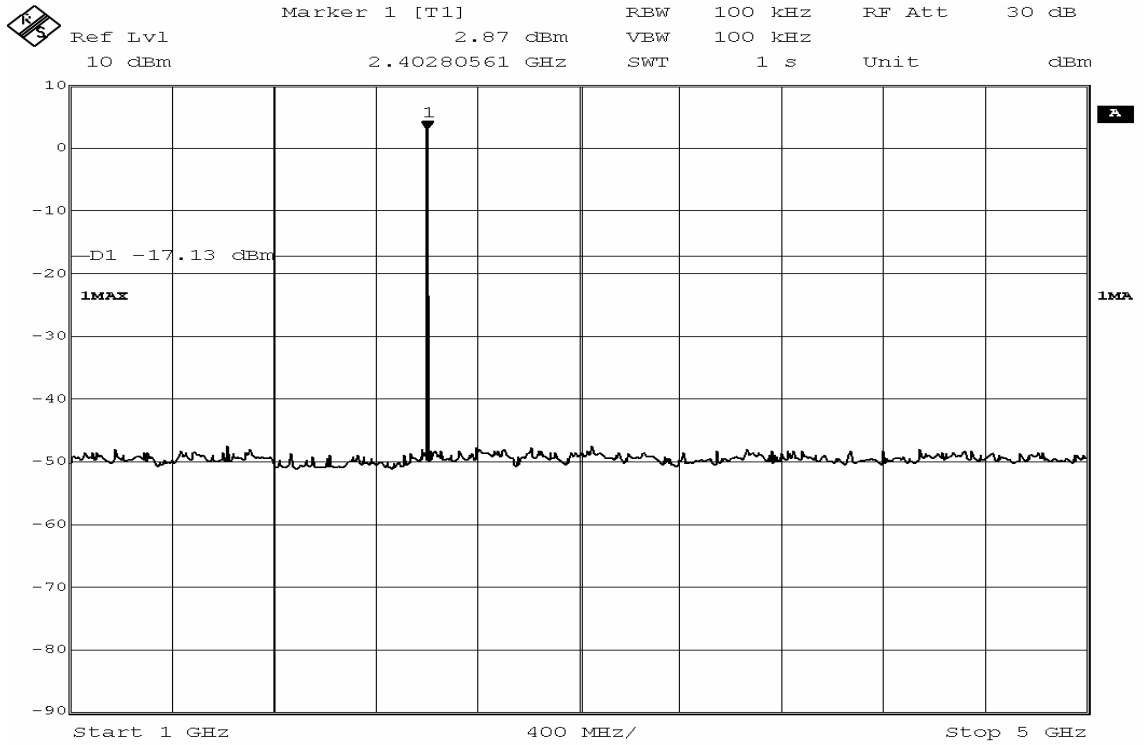

Date: 18.MAY.2007 10:22:11

5G to 25GHz

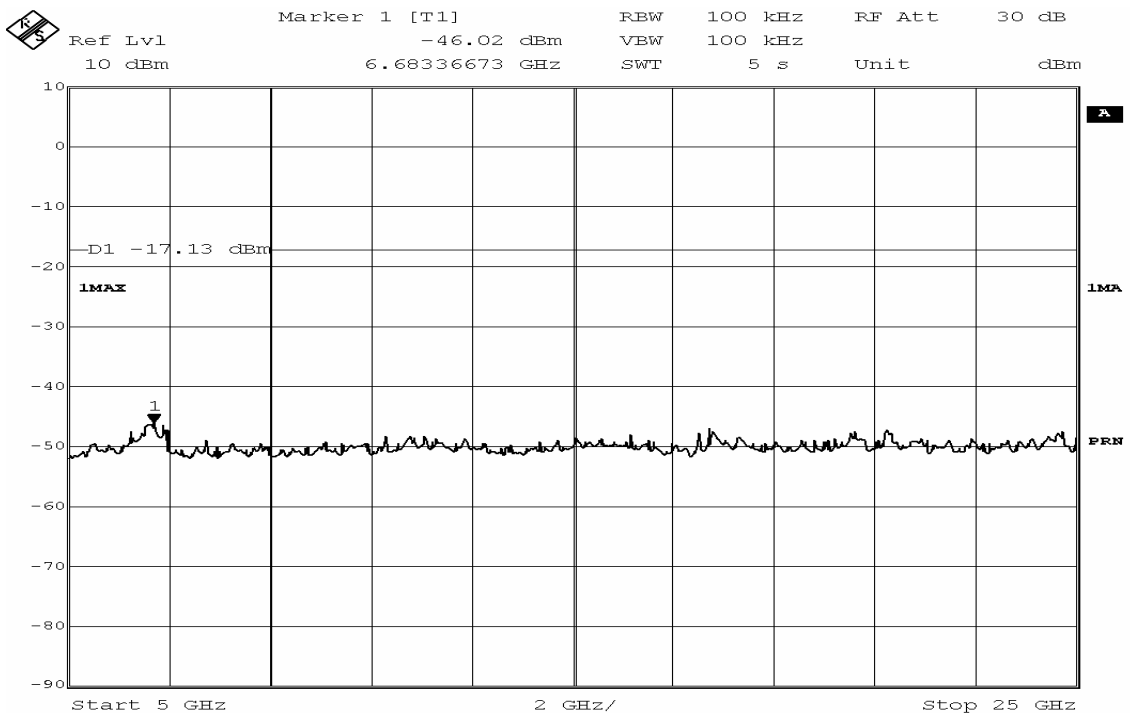

Date: 18.MAY.2007 10:23:13



Medium Channel (channel 39): 30M to 1GHz

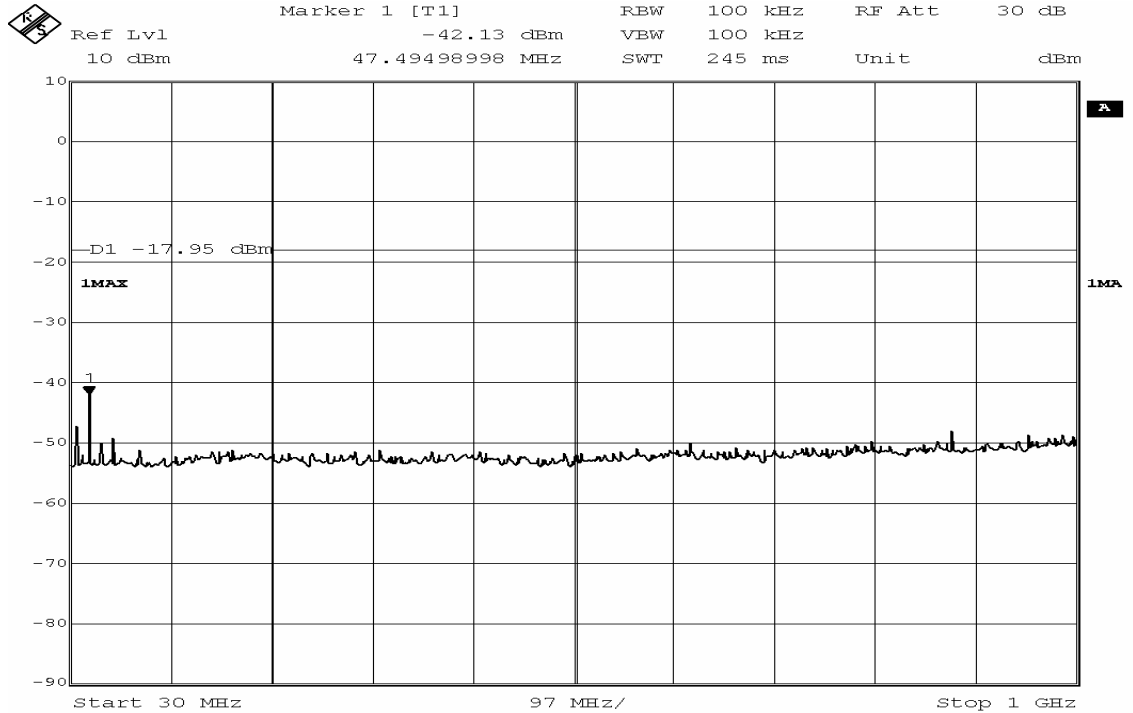

Date: 18.MAY.2007 10:17:14

1G to 5GHz

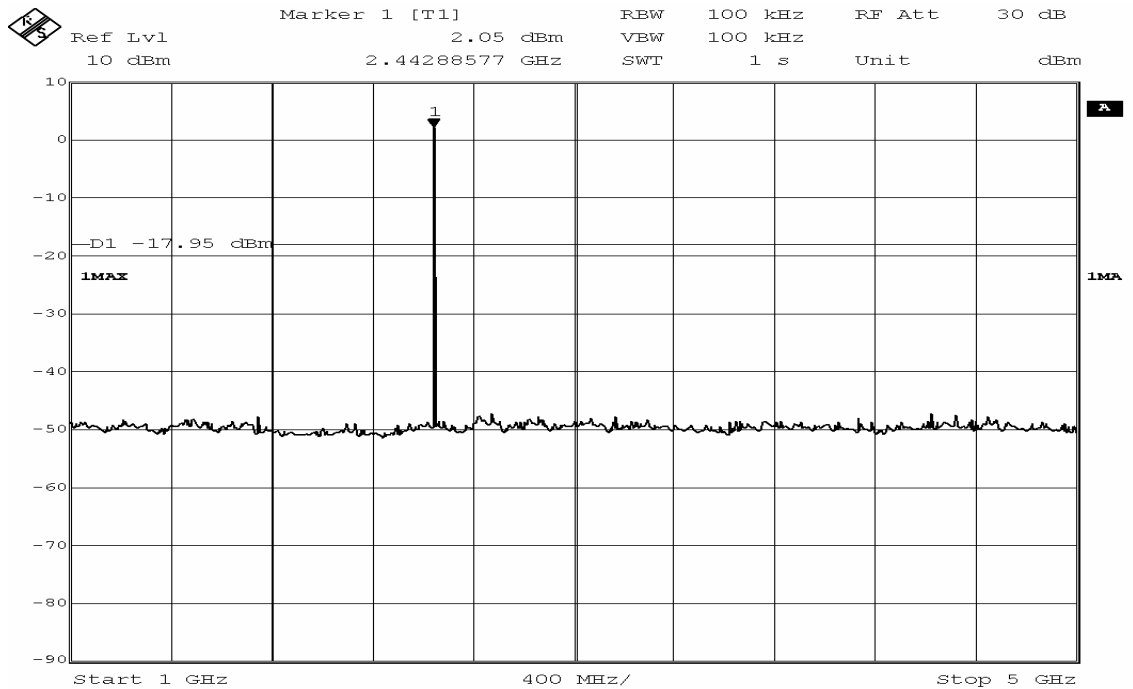

Date: 18.MAY.2007 10:15:24







1G to 5GHz

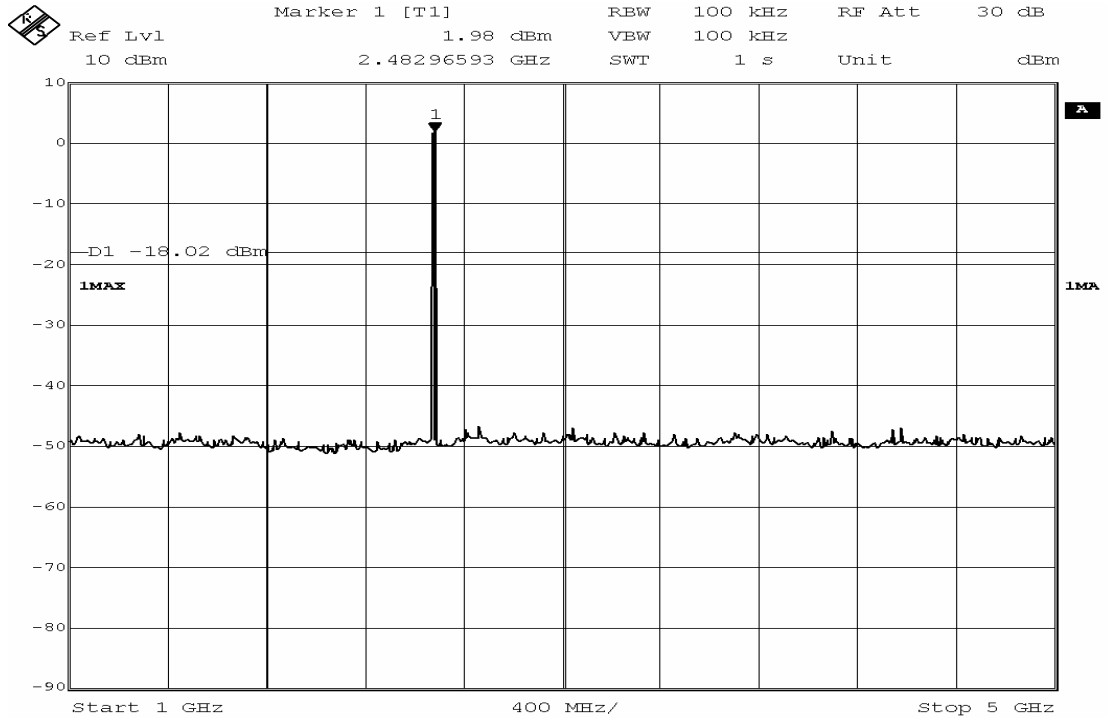

Date: 18.MAY.2007 10:13:06

5G to 25GHz

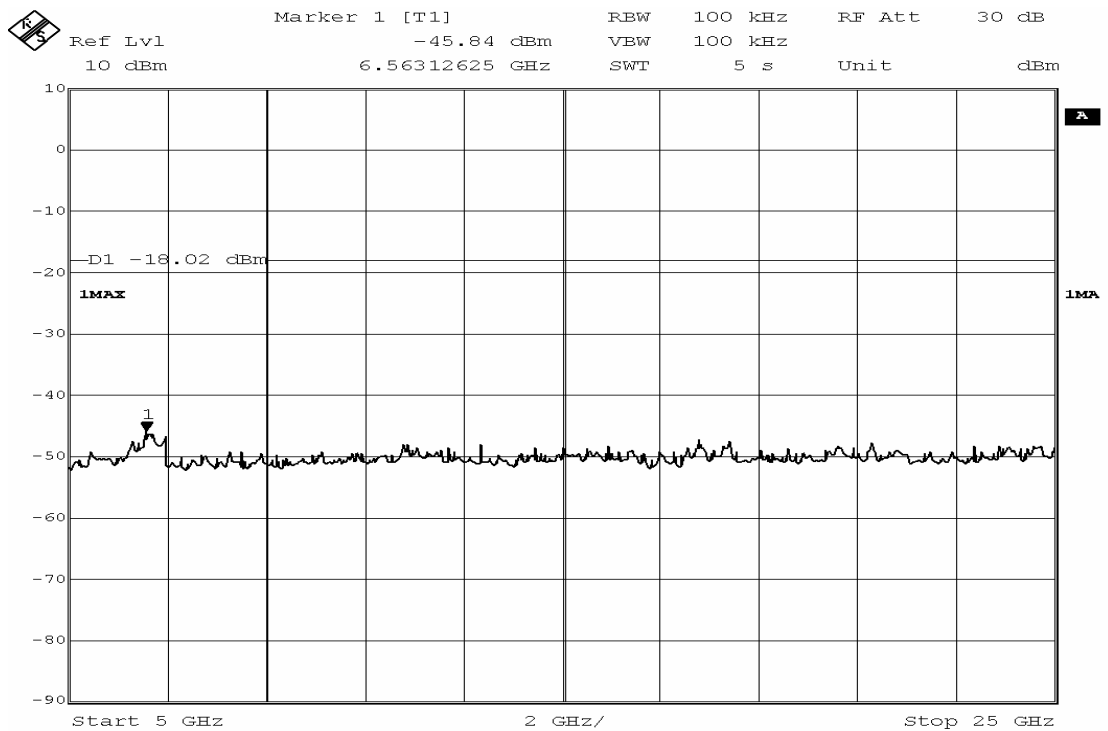

Date: 18.MAY.2007 10:14:02

## 6.6 Radiated Spurious Emissions

Test Requirement: FCC 15.247(d) & 15.209 & 15.109  
 Test Method: ANSI C63.4 section 8 & 13  
 Test Date: 28 May to 5 June 2007  
 Test site: Measurement Distance: 3m (Semi-Anechoic Chamber and OATS)  
 Test instrumentation resolution bandwidth 120 kHz and Quasi-Peak detector applies (30 MHz - 1000 MHz), 1 MHz resolution bandwidth and Peak and Average-Peak detector apply (1000 MHz – 25GHz).  
 Receive antenna scan height 1 m - 4 m, polarization Vertical / Horizontal

15.209 & 15.109 Limit: 40.0 dB $\mu$ V/m between 30MHz & 88MHz  
 43.5 dB $\mu$ V/m between 88MHz & 216MHz  
 46.0 dB $\mu$ V/m between 216MHz & 960MHz  
 54.0 dB $\mu$ V/m above 960MHz

15.247(d) limit: (d) In any 100 kHz bandwidth outside the frequency band in which the spread spectrum or digitally modulated intentional radiator is operating, the radio frequency power that is produced by the intentional radiator shall be at least 20 dB below that in the 100 kHz bandwidth within the band that contains the highest level of the desired power, based on either an RF conducted or a radiated measurement, provided the transmitter demonstrates compliance with the peak conducted power limits.

### Test Configuration:

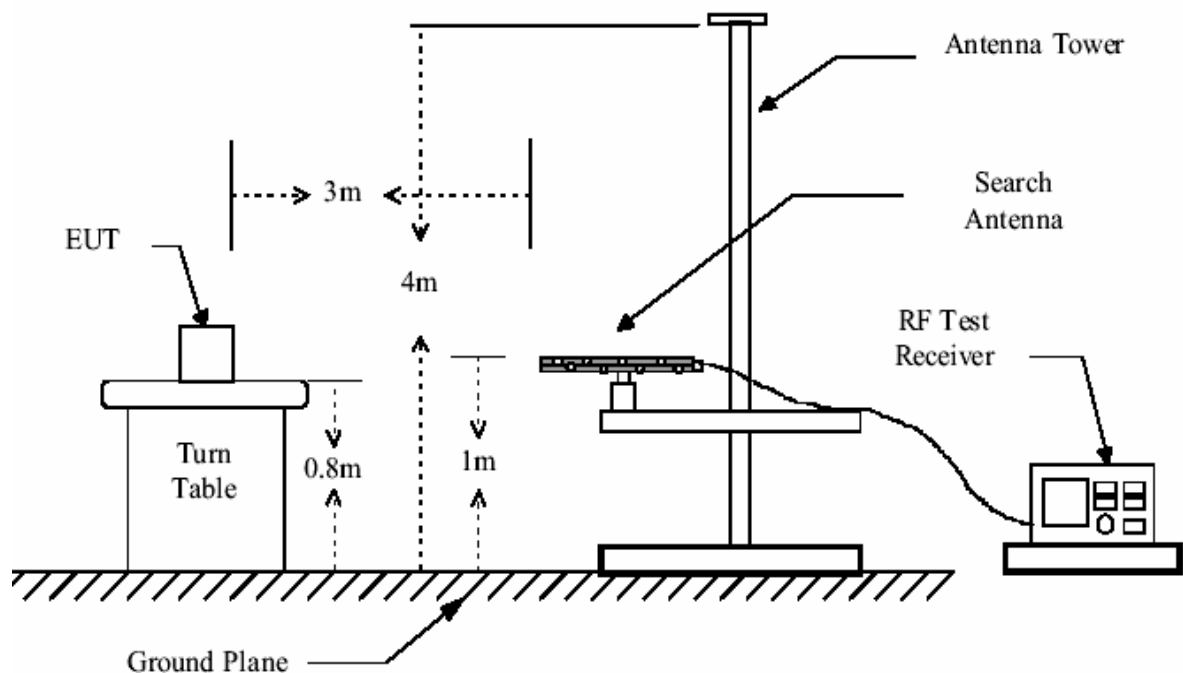

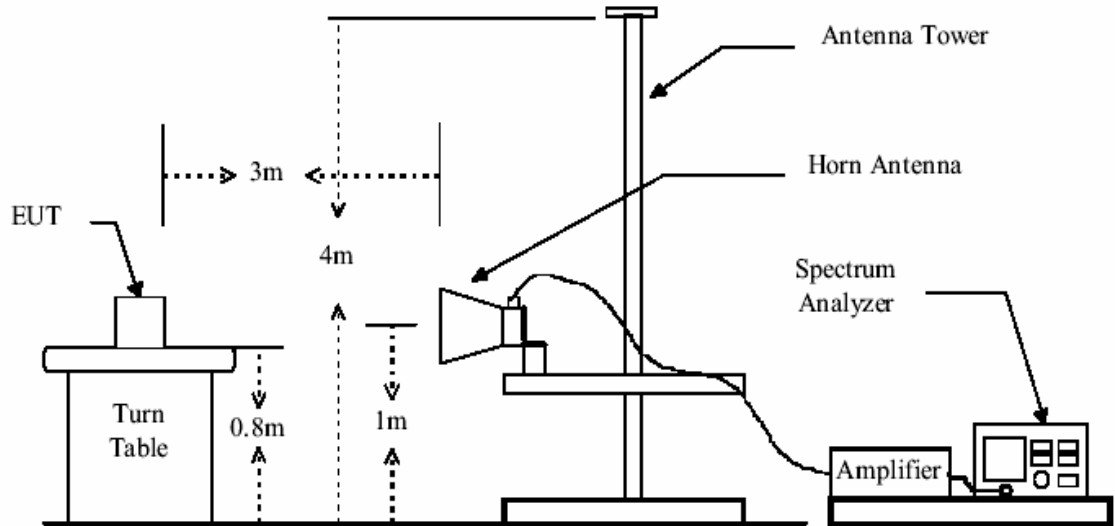



**Test Procedure:** The procedure used was ANSI Standard C63.4-2001. The receiver was scanned from 30MHz to 25GHz. When an emission was found, the table was rotated to produce the maximum signal strength. An initial pre-scan was performed for in peak detection mode using the receiver. The EUT was measured for both the Horizontal and Vertical polarities and performed a pre-test three orthogonal planes. For intentional radiators, measurements of the variation of the input power or the radiated signal level of the fundamental frequency component of the emission, as appropriate, shall be performed with the supply voltage varied between 85% and 115% of the nominal rated supply voltage. The worst case emissions were reported.

The field strength is calculated by adding the Antenna Factor, Cable Factor & Peramplifier. The basic equation with a sample calculation is as follows:

Final Test Level = Receiver Reading + Antenna Factor + Cable Factor – Peramplifier Factor.

The following test results were performed on the EUT.

**Bluetooth module:**

**Transmitter:**

**Test in Channel 0 in transmitting status-** Vertical polarization

30MHz~1GHz Spurious Emissions ,Quasi-Peak Measurement

Frequency (MHz)	Emission Level (dBuV/m)	Limit (dBuV/m)	Margin (dB)
625.580	38.3	46.0	7.7
824.430	41.5	46.0	4.5

1~25 GHz Harmonics & Spurious Emissions, Peak & Average Measurement

**Peak Measurement**

Frequency (MHz)	Emission Level (dBuV/m)	Limit (dBuV/m)	Margin (dB)
1581.000	46.0	74.0	28.0
4804.000	46.2	74.0	27.8

**Average Measurement**

Frequency (MHz)	Emission Level (dBuV/m)	Limit (dBuV/m)	Margin (dB)
1581.000	35.0	54.0	19.0
4804.000	35.2	54.0	18.8

Operating frequency:

Frequency (MHz)	Emission Level AV (dBuV/m)	Emission Level Peak (dBuV/m)
2402MHz	95.3	97.0

Remark: No other radiation has been found.



**Test in Channel 0 in transmitting status-** Horizontal polarization

30MHz~1GHz Spurious Emissions ,Quasi-Peak Measurement

Frequency (MHz)	Emission Level (dBuV/m)	Limit (dBuV/m)	Margin (dB)
824.430	41.0	46.0	5.0

1~25 GHz Harmonics & Spurious Emissions, Peak & Average Measurement

**Peak Measurement**

Frequency (MHz)	Emission Level (dBuV/m)	Limit (dBuV/m)	Margin (dB)
1609.000	46.0	74.0	28.0
4804.000	45.0	74.0	29.0

**Average Measurement**

Frequency (MHz)	Emission Level (dBuV/m)	Limit (dBuV/m)	Margin (dB)
1609.000	35.0	54.0	19.0
4804.000	32.5	54.0	21.5

Frequency (MHz)	Emission Level AV (dBuV/m)	Emission Level Peak (dBuV/m)
2402MHz	94.9	96.3

Remark: No other radiation has been found.

**Test in Channel 39 in transmitting status-** Vertical polarization

30MHz~1GHz Spurious Emissions ,Quasi-Peak Measurement

Frequency (MHz)	Emission Level (dBuV/m)	Limit (dBuV/m)	Margin (dB)
524.700	36.4	46.0	9.6

1~25 GHz Harmonics & Spurious Emissions, Peak & Average Measurement

**Peak Measurement**

Frequency (MHz)	Emission Level (dBuV/m)	Limit (dBuV/m)	Margin (dB)
4882.000	46.0	74.0	28.0



**Average Measurement**

Frequency (MHz)	Emission Level (dBuV/m)	Limit (dBuV/m)	Margin (dB)
4882.000	35.3	54.0	10.7

Frequency (MHz)	Emission Level AV (dBuV/m)	Emission Level Peak (dBuV/m)
2441MHz	94.2	95.9

**Test in Channel 39 in transmitting status- Horizontal polarization**

30MHz~1GHz Spurious Emissions ,Quasi-Peak Measurement

Frequency (MHz)	Emission Level (dBuV/m)	Limit (dBuV/m)	Margin (dB)
874.870	39.0	46.0	7.0

1~25 GHz Harmonics & Spurious Emissions, Peak & Average Measurement

**Peak Measurement**

Frequency (MHz)	Emission Level (dBuV/m)	Limit (dBuV/m)	Margin (dB)
1609.000	45.1	74.0	28.9
4882.000	46.0	74.0	28.0

**Average Measurement**

Frequency (MHz)	Emission Level (dBuV/m)	Limit (dBuV/m)	Margin (dB)
1609.000	35.0	54.0	19.0
4882.020	36.0	54.0	18.0

Frequency (MHz)	Emission Level AV (dBuV/m)	Emission Level Peak (dBuV/m)
2441MHz	93.8	95.0

Remark: No other radiation has been found.



**Test in Channel 78 in transmitting status- Vertical polarization**

30MHz~1GHz Spurious Emissions ,Quasi-Peak Measurement

Frequency (MHz)	Emission Level (dBuV/m)	Limit (dBuV/m)	Margin (dB)
276.380	36.0	46.0	10.0
676.020	38.0	46.0	8.0

1~25 GHz Harmonics & Spurious Emissions, Peak & Average Measurement

**Peak Measurement**

Frequency (MHz)	Emission Level (dBuV/m)	Limit (dBuV/m)	Margin (dB)
4960.000	54.0	74.0	20.0

**Average Measurement**

Frequency (MHz)	Emission Level (dBuV/m)	Limit (dBuV/m)	Margin (dB)
4960.000	41.0	54.0	13.0

Frequency (MHz)	Emission Level AV (dBuV/m)	Emission Level Peak (dBuV/m)
2480MHz	96.0	96.8

**Test in Channel 78 in transmitting status- Horizontal polarization**

30MHz~1GHz Spurious Emissions ,Quasi-Peak Measurement

Frequency (MHz)	Emission Level (dBuV/m)	Limit (dBuV/m)	Margin (dB)
276.380	36.4	46.0	10.6
773.990	40.9	46.0	5.1

1~25 GHz Harmonics & Spurious Emissions, Peak & Average Measurement

**Peak Measurement**

Frequency (MHz)	Emission Level (dBuV/m)	Limit (dBuV/m)	Margin (dB)
4960.000	47.0	74.0	24.0





**Average Measurement**

Frequency (MHz)	Emission Level (dBuV/m)	Limit (dBuV/m)	Margin (dB)
4960.000	35.0	54.0	21.0

Frequency (MHz)	Emission Level AV (dBuV/m)	Emission Level Peak (dBuV/m)
2480MHz	94.3	95.9

Remark: No other radiation has been found.

**Receiver:**

30MHz~25 GHz Harmonics & Spurious Emissions

Vertical polarization:

Frequency (MHz)	Peak (dBuV/m)	Average (dBuV/m)	Peak Limit (dBuV/m)	Average Limit (dBuV/m)
1609.000	44.8	26.9	74.0	54.0
4915.000	44.3	26.8	74.0	54.0

Horizontal polarization:

Frequency (MHz)	Peak (dBuV/m)	Average (dBuV/m)	Peak Limit (dBuV/m)	Average Limit (dBuV/m)
1609.000	43.2	26.3	74.0	54.0
4500.000	44.6	27.6	74.0	54.0

**None of radiation has been found in receiving mode.**

**TEST RESULTS: The unit does meet the FCC requirements.**



### 6.6.1 Radiated Emissions, 30MHz to 1GHz

Test Requirement:	FCC Rules Part 15 Subpart B
Test Method:	ANSI C63.4
Test Date:	28 May 2007 (Initial test) 06 June 2007 (1 <sup>st</sup> Retest)
Frequency Range:	30MHz to 1GHz
Measurement Distance:	3m
Class:	Class B
Limit:	40.0 dB $\mu$ V/m between 30MHz & 88MHz 43.5 dB $\mu$ V/m between 88MHz & 216MHz 46.0 dB $\mu$ V/m between 216MHz & 960MHz 54.0 dB $\mu$ V/m above 960MHz
Detector:	Peak for pre-scan Quasi-Peak(120kHz resolution bandwidth) if maximised peak within 6dB of limit

### 6.6.2 E.U.T. Operation

Operating Environment:					
Temperature:	29.0 °C	Humidity:	54 % RH	Atmospheric Pressure:	1012 Mbar
EUT Operation:	Test was performed in FM tuner mode (tuned at 108MHz as worst case), USB disk play mode, SD card play mode, i-Pod play mode (worse case of Aux and i-Pod play mode), MP3-CD play mode (worse case of CD and MP3-CD play mode).				

### 6.6.3 Measurement Data

An initial pre-scan was performed in the chamber using the spectrum analyser in peak detection mode. Quasi-peak measurements were conducted based on the peak sweep graph. The EUT was measured by Bilog antenna with 2 orthogonal polarities

The following Peak Scan and Quasi-peak measurements were performed on the EUT on 06 June 2007:



MP3-CD play mode:

Vertical:

Peak scan

Level (dB $\mu$ V/m)

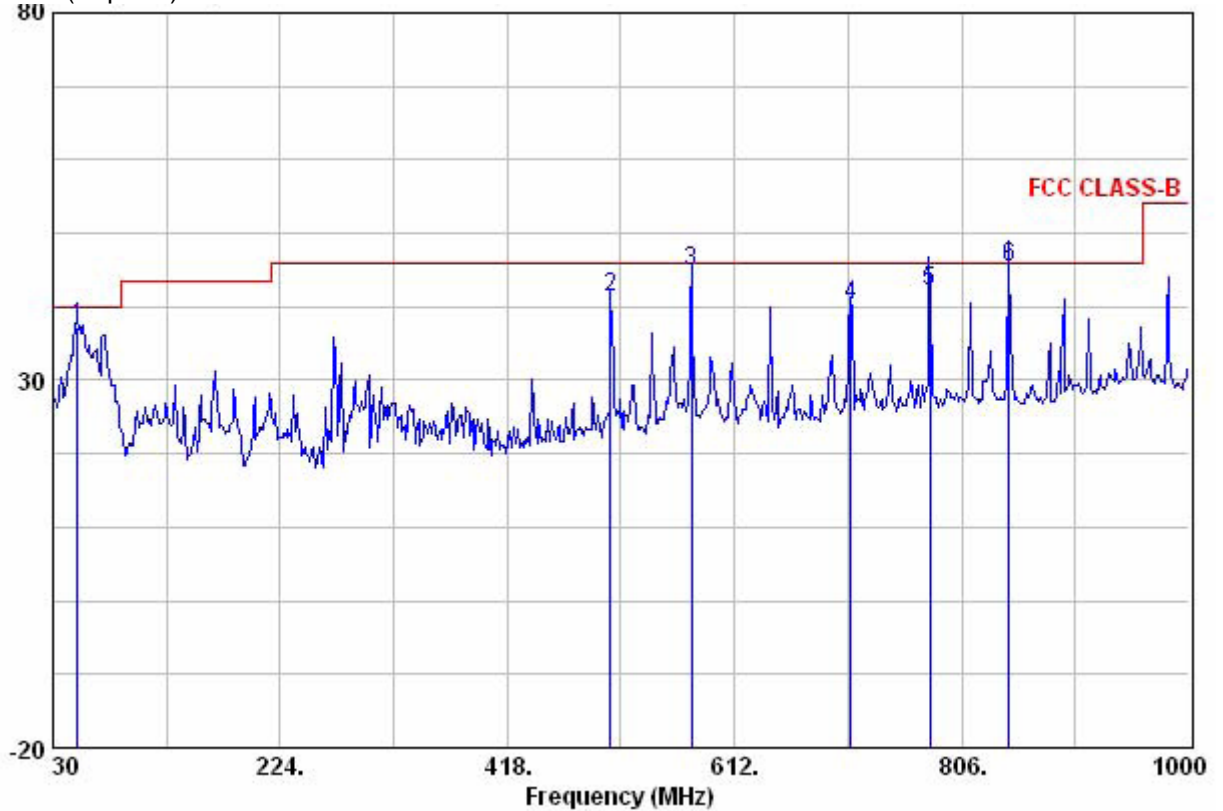

Quasi-peak measurement

Freq	ReadAntenna Level	Antenna Factor	Cable Loss	Preamp Factor	Level	Limit Line	Over Limit	Remark
MHz	dB $\mu$ V	dB/m	dB	dB	dB $\mu$ V/m	dB $\mu$ V/m	dB	
51.340	52.50	9.37	0.50	25.27	37.10	40.00	-2.90	QP
506.270	46.36	19.06	1.70	25.89	41.23	46.00	-4.77	QP
575.140	48.66	20.14	1.85	25.82	44.82	46.00	-1.18	QP
710.940	42.11	21.80	2.11	25.69	40.33	46.00	-5.67	QP
778.760	43.37	22.23	2.21	25.62	42.19	46.00	-3.81	QP
846.500	45.19	23.16	2.44	25.32	45.47	46.00	-0.53	QP



MP3-CD play mode:  
Horizontal:

Peak scan

Level (dB $\mu$ V/m)

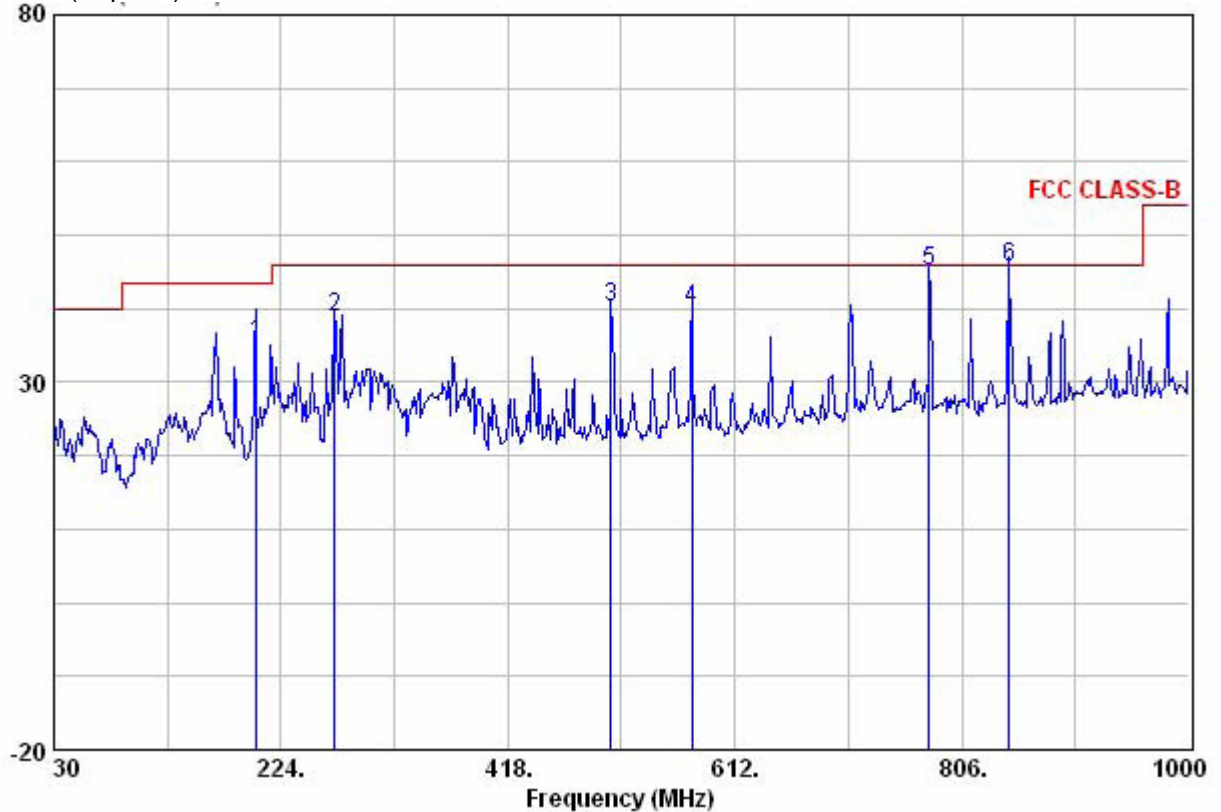

Quasi-peak measurement

Freq	Read Level	Antenna Factor	Cable Loss	Preamp Factor	Level	Limit Line	Over Limit	Remark
MHz	dB $\mu$ V	dB/m	dB	dB	dB $\mu$ V/m	dB $\mu$ V/m	dB	
203.220	49.43	9.35	1.04	24.58	35.23	43.50	-8.27	QP
269.590	49.46	12.76	1.10	24.40	38.92	46.00	-7.08	QP
506.270	46.35	18.17	1.70	25.89	40.32	46.00	-5.68	QP
575.140	43.96	20.07	1.85	25.82	40.06	46.00	-5.94	QP
777.870	46.36	22.15	2.22	25.62	45.11	46.00	-0.89	QP
846.500	45.57	22.97	2.44	25.32	45.67	46.00	-0.33	QP



FM tuner mode:

Vertical:

Peak scan

Level (dB $\mu$ V/m)

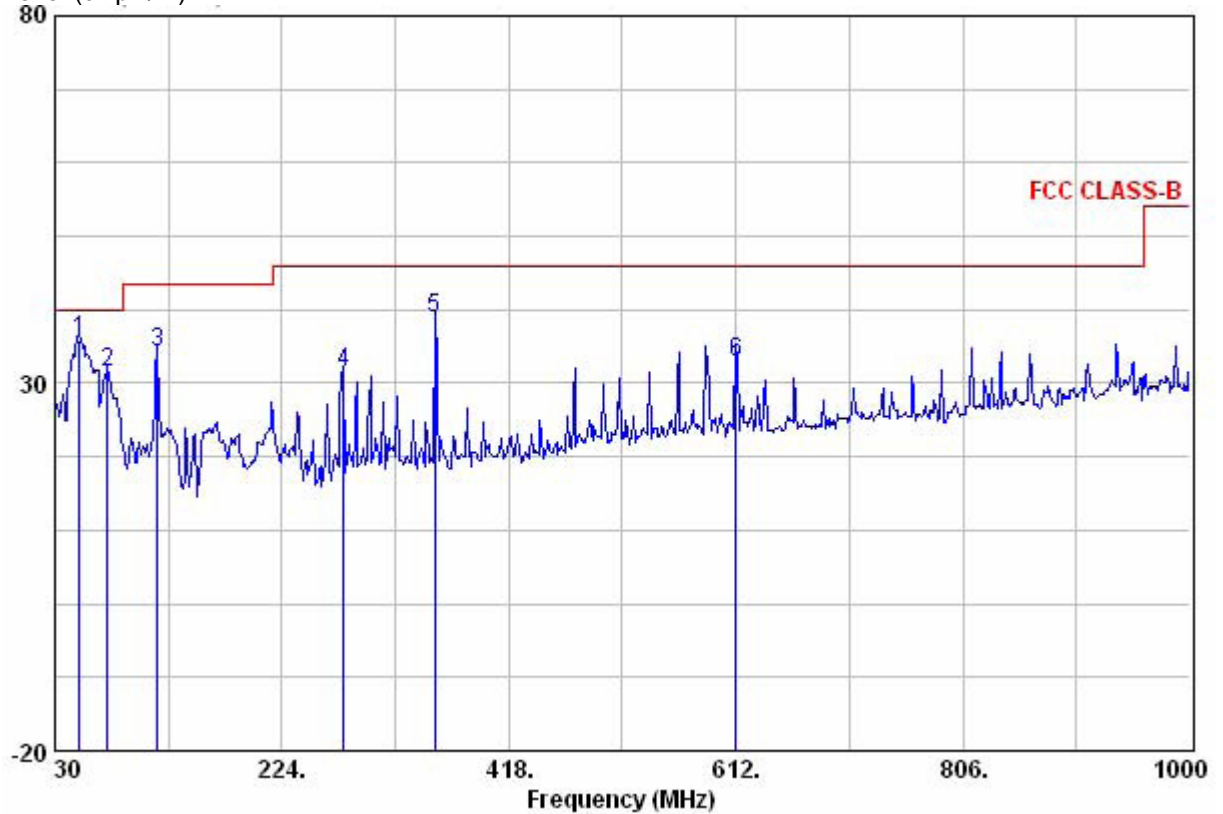

Quasi-peak measurement

Freq	ReadAntenna Level	Antenna Factor	Cable Loss	Preamplifier Factor	Level	Limit Line	Over Limit	Remark
MHz	dB $\mu$ V	dB/m	dB	dB	dB $\mu$ V/m	dB $\mu$ V/m	dB	
51.340	51.13	9.37	0.50	25.27	35.73	40.00	-4.27	QP
74.620	48.36	7.52	0.60	25.10	31.38	40.00	-8.62	QP
117.300	47.52	11.14	0.77	25.10	34.34	43.50	-9.16	QP
276.380	42.08	12.55	1.16	24.40	31.39	46.00	-14.61	QP
354.950	46.61	15.43	1.50	24.75	38.79	46.00	-7.21	QP
612.000	36.31	20.44	1.82	25.79	32.78	46.00	-13.22	QP



FM tuner mode:

Horizontal:

Peak scan

Level (dB $\mu$ V/m)

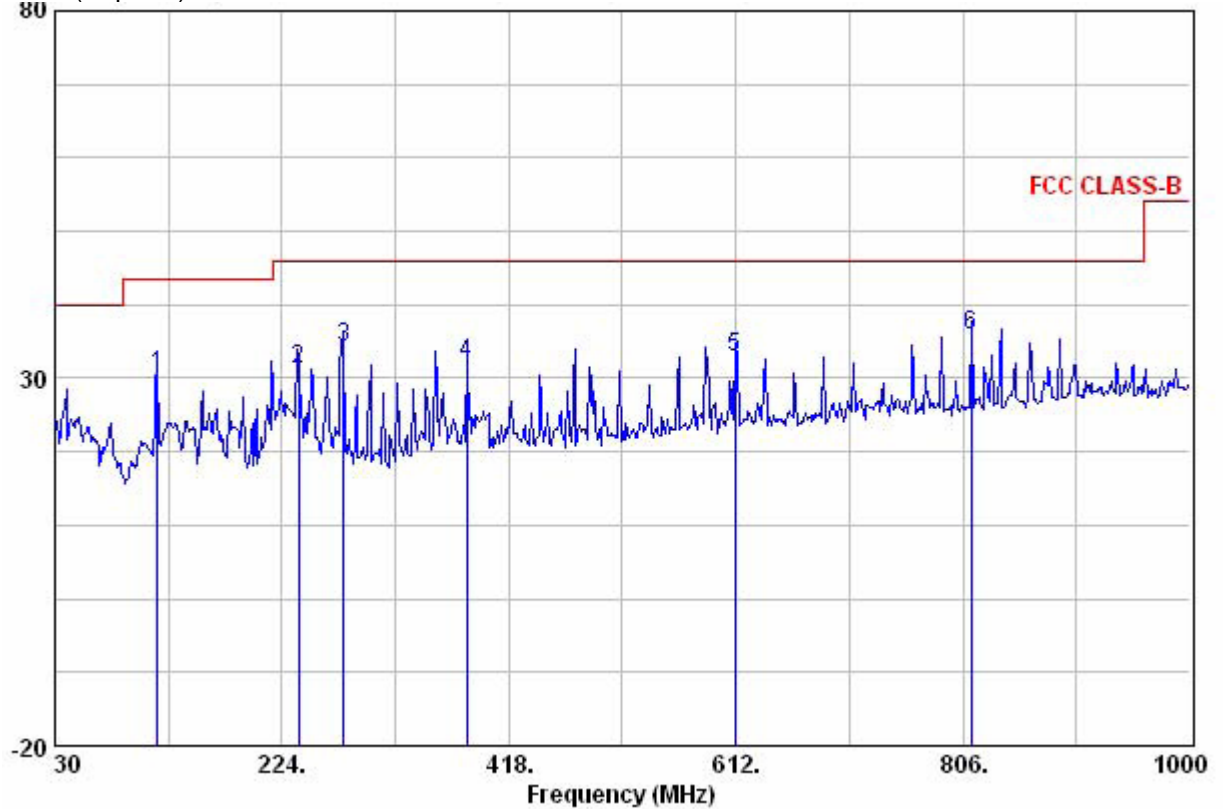

Quasi-peak measurement

Freq	Read Level	Antenna Factor	Cable Loss	Preamp Factor	Level	Limit	Over	Remark
MHz	dB $\mu$ V	dB/m	dB	dB	dB $\mu$ V/m	dB $\mu$ V/m	dB	
117.300	41.60	13.19	0.77	25.10	30.46	43.50	-13.04	QP
238.550	42.00	12.47	1.10	24.44	31.12	46.00	-14.88	QP
276.380	44.49	12.83	1.16	24.40	34.09	46.00	-11.91	QP
382.110	39.50	16.15	1.42	24.90	32.17	46.00	-13.83	QP
611.030	36.74	19.99	1.81	25.79	32.75	46.00	-13.25	QP
812.790	36.87	22.25	2.23	25.51	35.84	46.00	-10.16	QP



USB disk play mode:

Vertical:

Peak scan

Level (dB $\mu$ V/m)

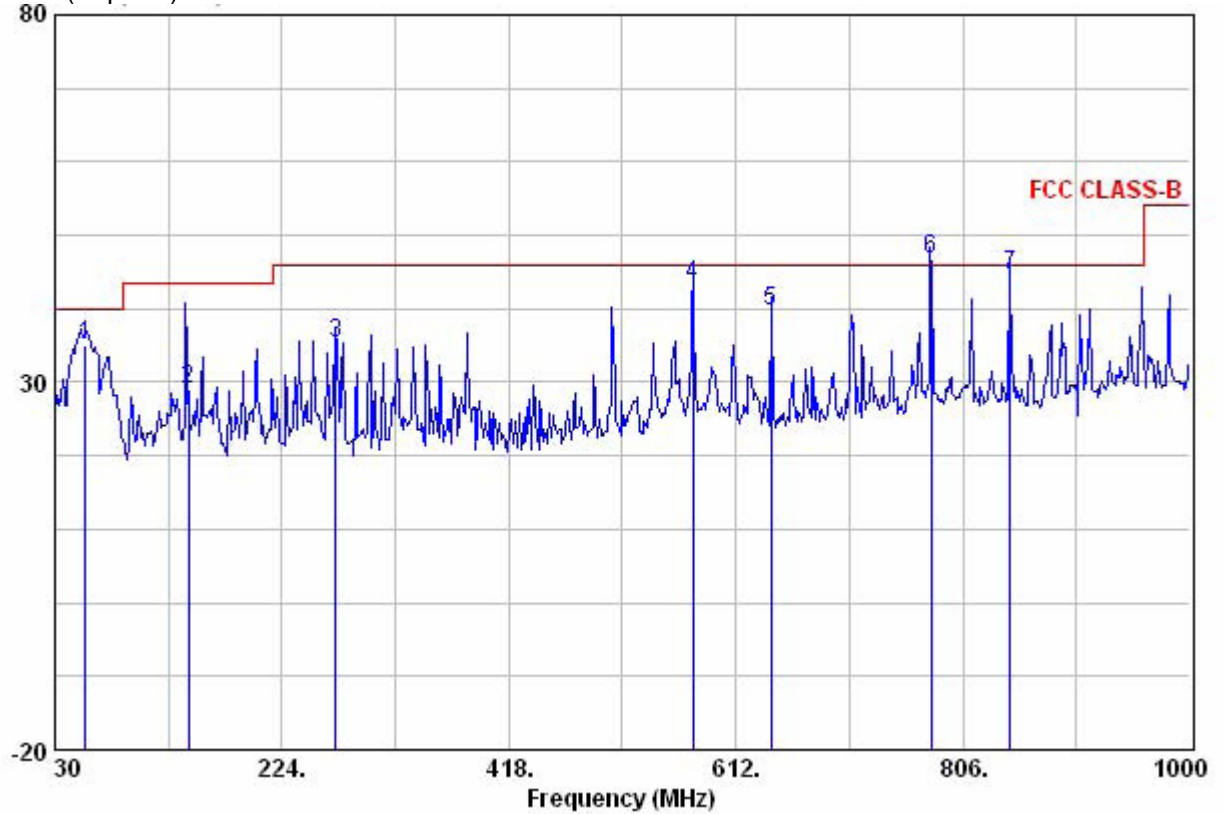

Quasi-peak measurement

Freq	Read Level	Antenna Factor	Cable Loss	Preamp Factor	Limit Line	Over Limit	Remark
MHz	dB $\mu$ V	dB/m	dB	dB	dB $\mu$ V/m	dB $\mu$ V/m	dB
56.190	53.01	6.73	0.50	25.17	35.06	40.00	-4.94 QP
144.020	43.69	9.66	0.80	25.02	29.14	43.50	-14.36 QP
269.590	45.81	12.87	1.10	24.40	35.37	46.00	-10.63 QP
575.140	46.94	20.14	1.85	25.82	43.10	46.00	-2.90 QP
642.070	43.02	20.39	1.90	25.75	39.56	46.00	-6.44 QP
778.800	46.35	22.23	2.21	25.62	45.17	46.00	-0.83 QP
846.740	44.39	23.16	2.44	25.30	44.69	46.00	-1.31 QP



USB disk play mode:  
Horizontal:

Peak scan

Level (dB $\mu$ V/m)

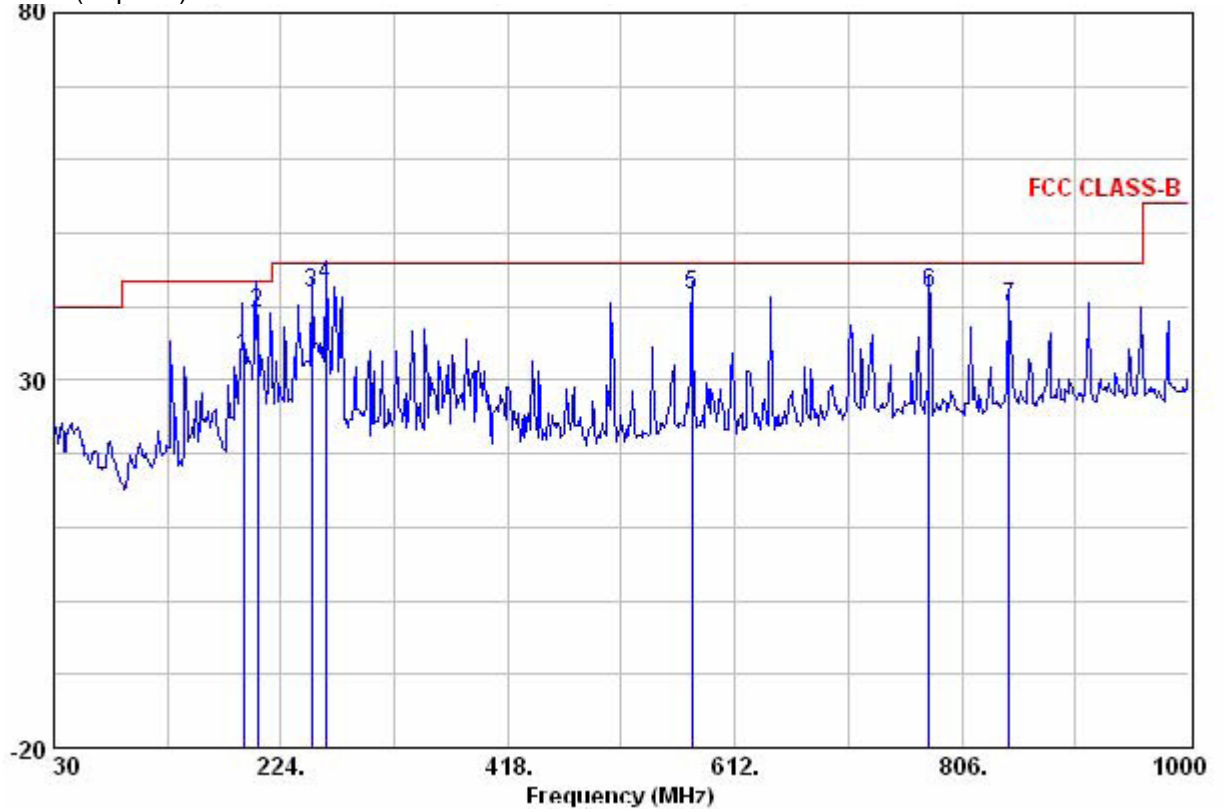

Quasi-peak measurement

Freq	Read Level	Antenna Factor	Cable Loss	Preamp Factor	Level	Limit Line	Over Limit	Remark
MHz	dB $\mu$ V	dB/m	dB	dB	dB $\mu$ V/m	dB $\mu$ V/m	dB	
191.940	48.28	8.66	1.00	24.68	33.27	43.50	-10.23	QP
204.020	53.20	9.35	1.04	24.58	39.00	43.50	-4.50	QP
250.190	52.51	12.50	1.20	24.40	41.80	46.00	-4.20	QP
261.830	52.65	13.47	1.18	24.40	42.89	46.00	-3.11	QP
575.140	45.38	20.07	1.85	25.82	41.48	46.00	-4.52	QP
777.870	43.17	22.15	2.22	25.62	41.92	46.00	-4.08	QP
846.740	39.75	22.97	2.44	25.30	39.87	46.00	-6.13	QP





SD card play mode:  
Vertical:

Peak scan

Level (dB $\mu$ V/m)

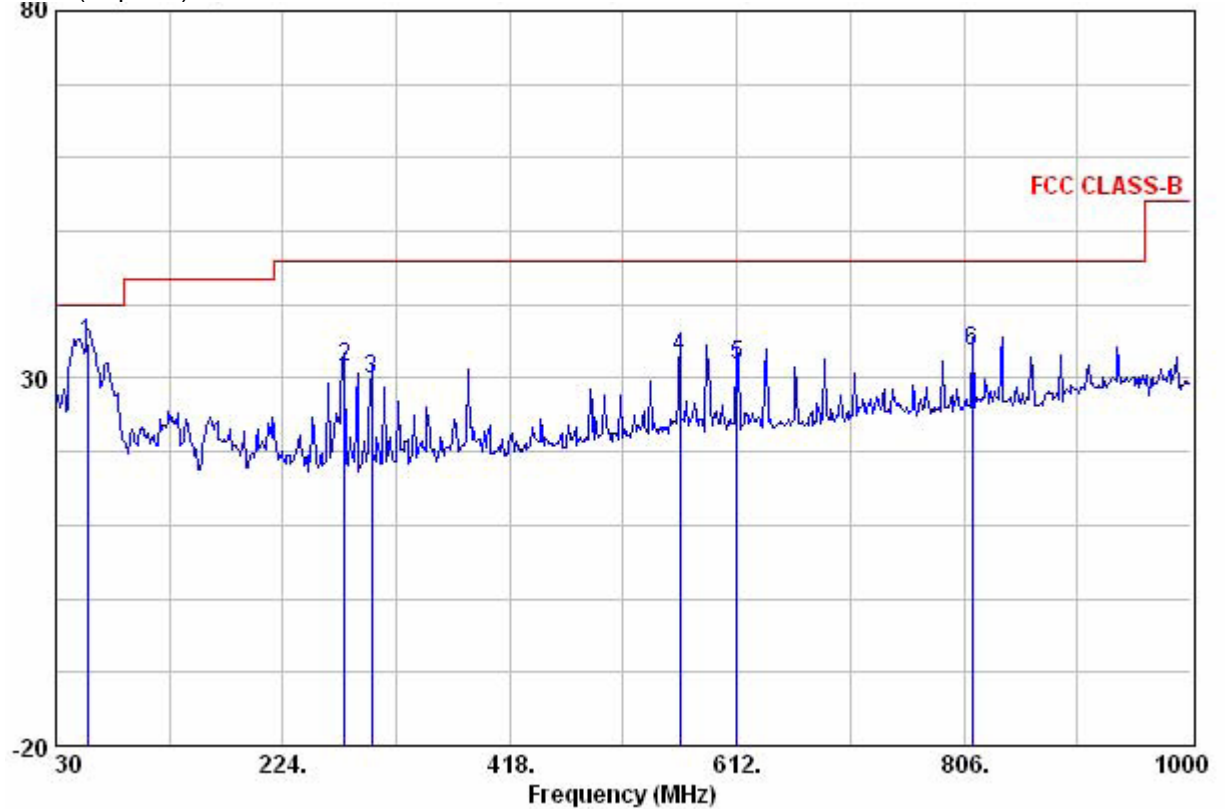

Quasi-peak measurement

Freq	Read Level	Antenna Factor	Cable Loss	Preamp Factor	Level	Limit	Over	Remark
MHz	dB $\mu$ V	dB/m	dB	dB	dB $\mu$ V/m	dB $\mu$ V/m	dB	
57.160	52.60	6.72	0.50	25.15	34.67	40.00	-5.33	QP
276.380	42.07	12.55	1.16	24.40	31.39	46.00	-14.61	QP
299.660	39.24	13.71	1.30	24.40	29.85	46.00	-16.15	QP
563.500	36.33	20.57	1.74	25.83	32.80	46.00	-13.20	QP
612.000	35.17	20.44	1.82	25.79	31.65	46.00	-14.35	QP
812.790	34.08	22.90	2.23	25.51	33.71	46.00	-12.29	QP



SD card play mode:  
Horizontal:

Peak scan

Level (dB $\mu$ V/m)

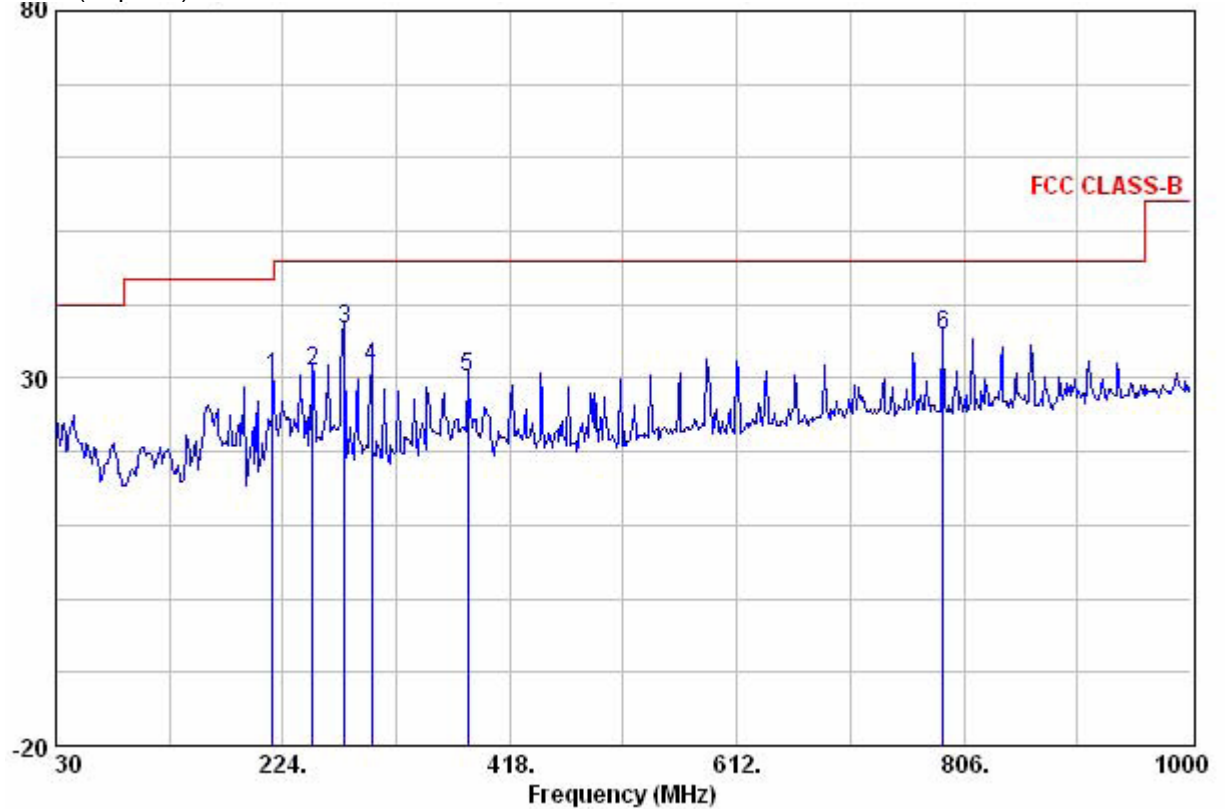

Quasi-peak measurement

Freq	Read Level	Antenna Factor	Cable Loss	Preamp Factor	Level	Limit Line	Over Limit	Remark
MHz	dB $\mu$ V	dB/m	dB	dB	dB $\mu$ V/m	dB $\mu$ V/m	dB	
215.270	43.21	10.48	1.10	24.53	30.26	43.50	-13.24	QP
249.220	41.56	12.54	1.19	24.40	30.89	46.00	-15.11	QP
276.380	47.07	12.83	1.16	24.40	36.67	46.00	-9.33	QP
299.660	40.56	13.90	1.30	24.40	31.37	46.00	-14.63	QP
382.110	37.59	16.15	1.42	24.90	30.26	46.00	-15.74	QP
788.540	37.28	22.03	2.12	25.61	35.81	46.00	-10.19	QP



I-Pod play mode:

Vertical:

Peak scan

Level (dB $\mu$ V/m)

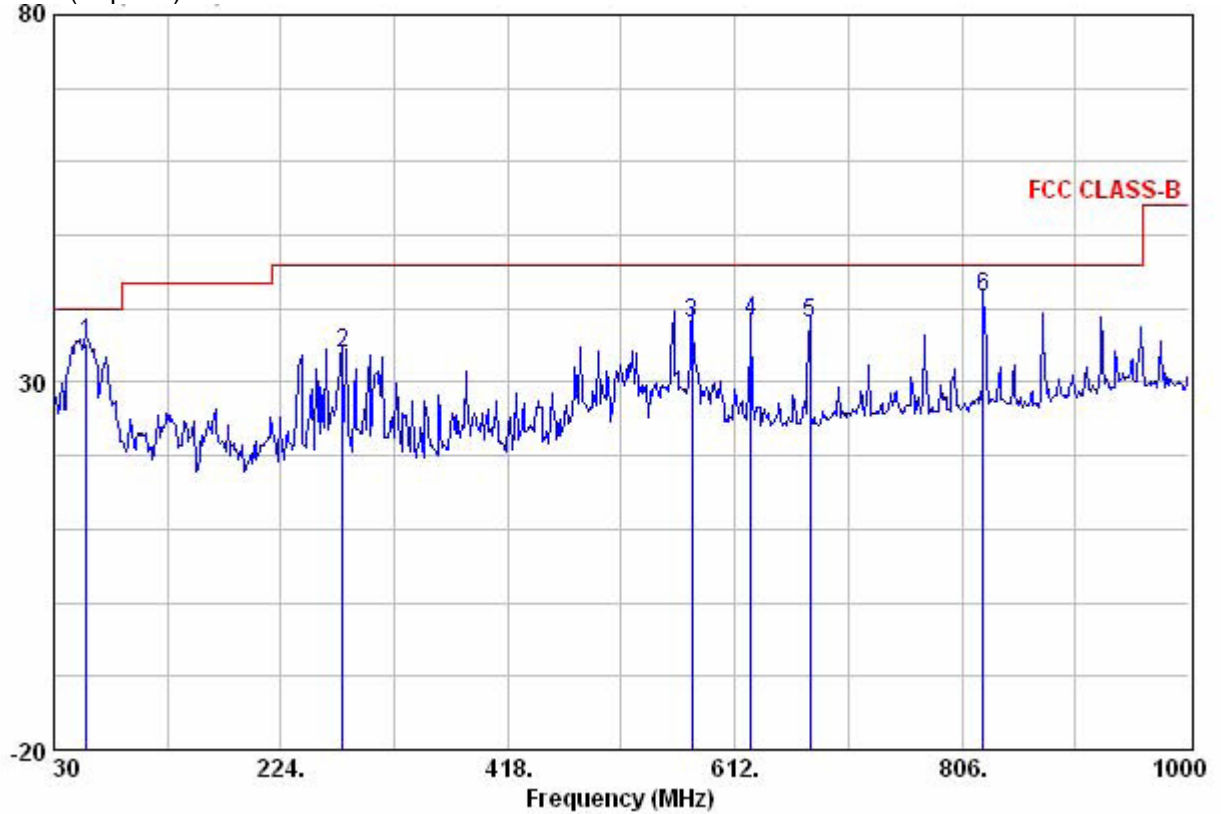

Quasi-peak measurement

Freq	ReadAntenna	Cable	Preamp	Limit	Over	Remark	
MHz	Level	Factor	Loss	Line	Limit		
	dB $\mu$ V	dB/m	dB	dB	dB $\mu$ V/m	dB $\mu$ V/m	
58.130	53.11	6.73	0.50	25.13	35.20	40.00	-4.80 QP
276.380	44.65	12.55	1.16	24.40	33.97	46.00	-12.03 QP
575.140	41.88	20.14	1.85	25.82	38.04	46.00	-7.96 QP
625.580	41.43	20.72	1.95	25.77	38.33	46.00	-7.67 QP
676.020	41.04	20.63	2.08	25.72	38.02	46.00	-7.98 QP
824.430	41.22	23.41	2.30	25.44	41.50	46.00	-4.50 QP



I -Pod play mode:  
Horizontal:

Peak scan

Level (dBμV/m)

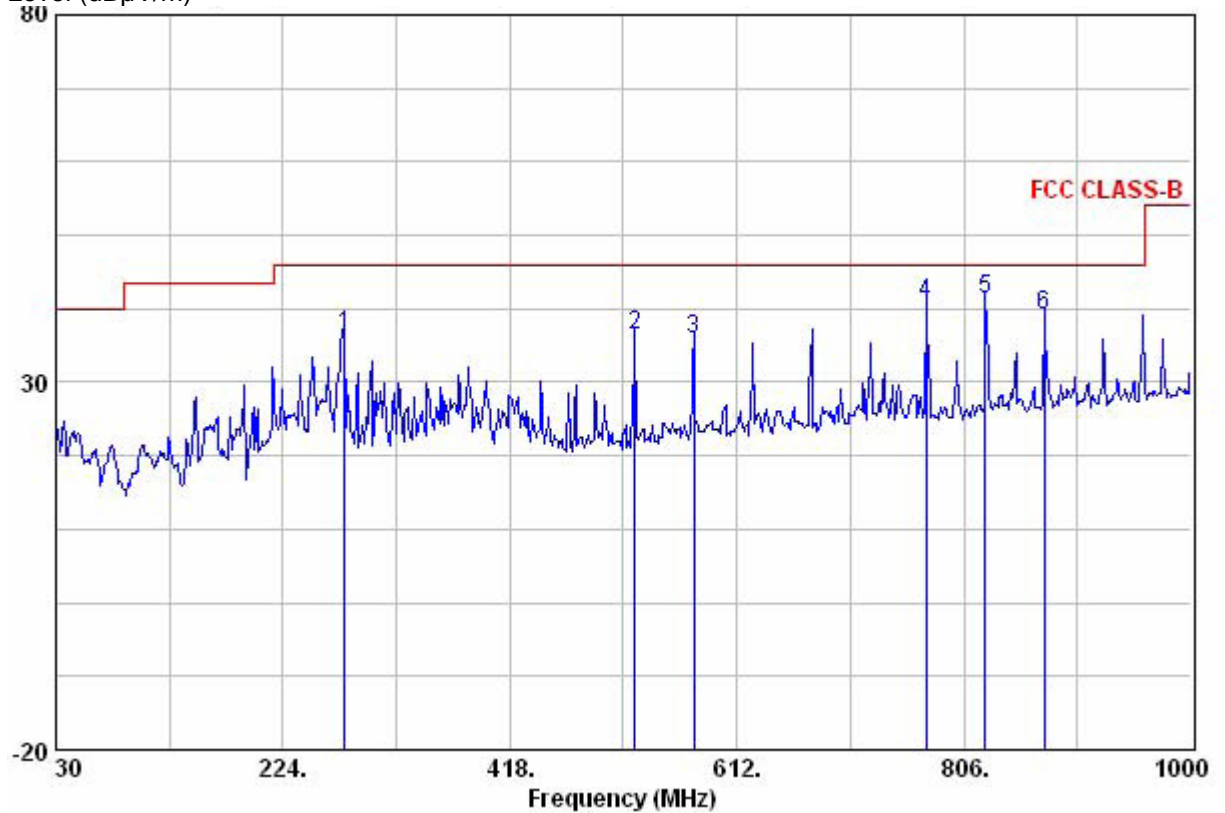

Quasi-peak measurement

Freq	Read Level	Antenna Factor	Cable Loss	Preamp Factor	Level	Limit Line	Over Limit	Remark
MHz	dBμV	dB/m	dB	dB	dBμV/m	dBμV/m	dB	
276.380	46.78	12.83	1.16	24.40	36.38	47.00	-10.62	QP
524.700	41.90	18.59	1.75	25.87	36.37	47.00	-10.63	QP
575.140	39.73	20.07	1.85	25.82	35.82	47.00	-11.18	QP
773.990	42.11	22.13	2.26	25.62	40.87	47.00	-6.13	QP
824.430	41.79	22.55	2.30	25.44	41.20	47.00	-5.80	QP
874.870	39.37	22.68	2.30	25.14	39.21	47.00	-7.79	QP

Level = Read Level + Antenna Factor + Cable Loss – Preamp Factor.

### 6.6.4 Radiated Emissions which fall in the restricted bands

Test Requirement:	Section 15.247 (d) In addition, radiated emissions which fall in the restricted bands, as defined in Section 15.205(a), must also comply with the radiated emission limits specified in Section 15.209(a) (see Section 15.205(c)).
Test Method:	Base on ANSI 63.4.
Test Date:	28 May 2007
Measurement Distance:	3m (Semi-Anechoic Chamber)
Limit:	40.0 dB $\mu$ V/m between 30MHz & 88MHz 43.5 dB $\mu$ V/m between 88MHz & 216MHz 46.0 dB $\mu$ V/m between 216MHz & 960MHz 54.0 dB $\mu$ V/m above 960MHz
Detector:	Peak for pre-scan , 120kHz resolution bandwidth within 1GHz, 1MHz resolution bandwidth above 1GHz

#### Test Configuration:

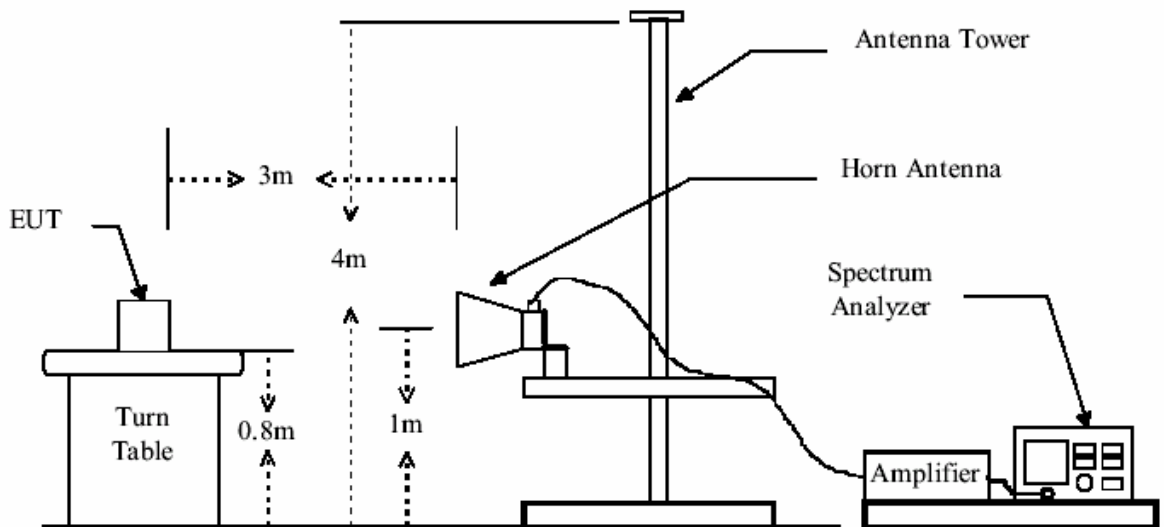



**Test Procedure:** The procedure used was ANSI Standard C63.4-2003. The receiver was scanned from 30MHz to 25GHz. When an emission was found, the table was rotated to produce the maximum signal strength. An initial pre-scan was performed for in peak detection mode using the receiver. The EUT was measured for both the Horizontal and Vertical polarities and performed a pre-test three orthogonal planes. For intentional radiators, measurements of the variation of the input power or the radiated signal level of the fundamental frequency component of the emission, as appropriate, shall be performed with the supply voltage varied between 85% and 115% of the nominal rated supply voltage. The worst case emissions were reported.

The field strength is calculated by adding the Antenna Factor, Cable Factor & Preamplifier. The basic equation with a sample calculation is as follows:

$$\text{Final Test Level} = \text{Receiver Reading} + \text{Antenna Factor} + \text{Cable Factor} - \text{Preamplifier Factor}$$

**Test Result:**

**1. Channel 0 ( 2.402GHz)**

Test Frequency (MHz)	Peak Level (dBuV/m)	Average Level (dBuV/m)	Peak Limit (dBuV/m)	Average Limit (dBuV/m)	Margin (dB)	
					Peak	AV
2390.000	45.0	32.0	74.0	54.0	29.0	22.0
2483.500	45.0	33.0	74.0	54.0	29.0	11.0

**2. Channel 39 ( 2.441GHz)**

Test Frequency (MHz)	Peak Level (dBuV/m)	Average Level (dBuV/m)	Peak Limit (dBuV/m)	Average Limit (dBuV/m)	Margin (dB)	
					Peak	AV
2390.000	46.0	33.0	74.0	54.0	28.0	22.0
2483.500	45.0	32.5	74.0	54.0	29.0	21.5

**3. Channel 79 ( 2.480GHz)**

Test Frequency (MHz)	Peak Level (dBuV/m)	Average Level (dBuV/m)	Peak Limit (dBuV/m)	Average Limit (dBuV/m)	Margin (dB)	
					Peak	AV
2390.000	46.0	33.0	74.0	54.0	28.0	21.0
2483.500	45.5	33.0	74.0	54.0	28.5	21.0

The unit does meet the FCC requirements.



Section 15.205 Restricted bands of operation.

(a) Except as shown in paragraph (d) of this section, only spurious emissions are permitted in any of the frequency bands listed below:

MHz	MHz	MHz	GHz
0.090 - 0.110	16.42 - 16.423	399.9 - 410	4.5 - 5.15
<sup>1</sup> 0.495 - 0.505	16.69475 - 16.69525	608 - 614	5.35 - 5.46
2.1735 - 2.1905	16.80425 - 16.80475	960 - 1240	7.25 - 7.75
4.125 - 4.128	25.5 - 25.67	1300 - 1427	8.025 - 8.5
4.17725 - 4.17775	37.5 - 38.25	1435 - 1626.5	9.0 - 9.2
4.20725 - 4.20775	73 - 74.6	1645.5 - 1646.5	9.3 - 9.5
6.215 - 6.218	74.8 - 75.2	1660 - 1710	10.6 - 12.7
6.26775 - 6.26825	108 - 121.94	1718.8 - 1722.2	13.25 - 13.4
6.31175 - 6.31225	123 - 138	2200 - 2300	14.47 - 14.5
8.291 - 8.294	149.9 - 150.05	2310 - 2390	15.35 - 16.2
8.362 - 8.366	156.52475 - 156.52525	2483.5 - 2500	17.7 - 21.4
8.37625 - 8.38675	156.7 - 156.9	2655 - 2900	22.01 - 23.12
8.41425 - 8.41475	162.0125 - 167.17	3260 - 3267	23.6 - 24.0
12.29 - 12.293	167.72 - 173.2	3332 - 3339	31.2 - 31.8
12.51975 - 12.52025	240 - 285	3345.8 - 3358	36.43 - 36.5
12.57675 - 12.57725	322 - 335.4	3600 - 4400	( <sup>2</sup> )
13.36 - 13.41			



## 6.7 Band Edges Requirement

Test Requirement:	FCC Part 15 C
Test Method:	Based on ANSI 63.4 Operation within the band 2400 – 2483.5 MHz
Test Date:	18 May 2007
Requirements:	Section 15.247 (d) In any 100 kHz bandwidth outside the frequency band in which the spread spectrum or digitally modulated intentional radiator is operating, the radio frequency power that is produced by the intentional radiator shall be at least 20 dB below that in the 100 kHz bandwidth within the band that contains the highest level of the desired power, based on either an RF conducted or a radiated measurement, provided the transmitter demonstrates compliance with the peak conducted power limits. If the transmitter complies with the conducted power limits based on the use of RMS averaging over a time interval, as permitted under paragraph (b)(3) of this section, the attenuation required under this paragraph shall be 30 dB instead of 20 dB. Attenuation below the general limits specified in Section 15.209(a) is not required. In addition, radiated emissions which fall in the restricted bands, as defined in Section 15.205(a), must also comply with the radiated emission limits specified in Section 15.209(a) (see Section 15.205(c)).

### 6.7.1 100 kHz Bandwidth Outside the Frequency Band

Method of Measurement:	Set RBW of spectrum analyzer to 100 kHz and VBW of spectrum analyzer to 100 kHz with suitable frequency span including 100 kHz bandwidth from band edge. The band edges was measured and recorded at operating frequency 2402MHz and 2480MHz.
------------------------	--

#### Test Result:

The Lower Edge 2.4000GHz: the value is -51.48dB that is attenuated more than 20dB;

The Upper Edge 2.4835GHz: the value is -53.17dB that is attenuated more than 20dB.

**The unit does meet the FCC requirements.**



### 6.8 Hopping Channel Number

Test Requirement: FCC Part15 C  
 Test Method: Based on FCC Part15 C Section 15.247  
 Test Date: 18 May 2007  
 Requirements: Regulation 15.247 (a) (1)(iii) Frequency hopping systems in the 2400-2483.5 MHz band shall use at least 15 channels.

- Test Procedure:
1. Remove the antenna from the EUT and then connect a low RF cable from the antenna port to the spectrum.
  2. Set the spectrum analyzer: RBW = 100KHz, VBW = 100KHz, Sweep = auto; Detector Function = Peak.
  3. Set the spectrum analyzer: start frequency = 2400MHz, stop frequency = 2483.5MHz. Record the max. hold reading graph.

**Test result:** Total channels are 79 channels, channel 0 to channel 78.

It also comply with the demand of frequency hopping systems operating in the 2400-2483.5 MHz band employing at least 75 non-overlapping hopping channels. The Maximum peak conducted output power limit apply 1 watt according to regulation 15.247 (b)(1).

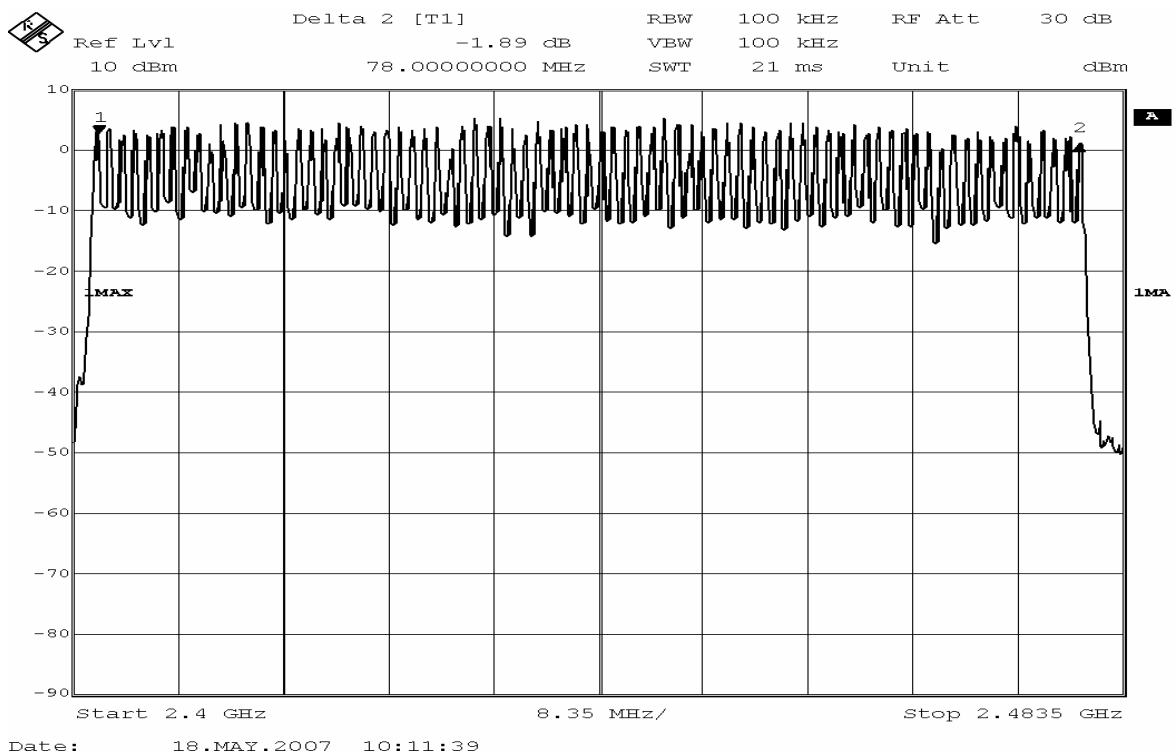



### 6.9 Occupied Bandwidth

Test Requirement: FCC Part 15 C  
 Test Method: Based on FCC Part15 C Section 15.247:  
 Test Date: 28 May 2007  
 Test Procedure:

1. Remove the antenna from the EUT and then connect a low RF cable from the antenna port to the spectrum.
2. Set the spectrum analyzer: RBW  $\geq$  1% of the 20dB bandwidth (set 10KHz), VBW  $\geq$  RBW , Sweep = auto; Detector Function = Peak (Max. hold).
3. Mark the peak frequency and -20dB points.

**Test result:**

Test Channel	20 dB bandwidth
0	792.0KHz
39	840.0KHz
78	840.0KHz

**Channel 0:**

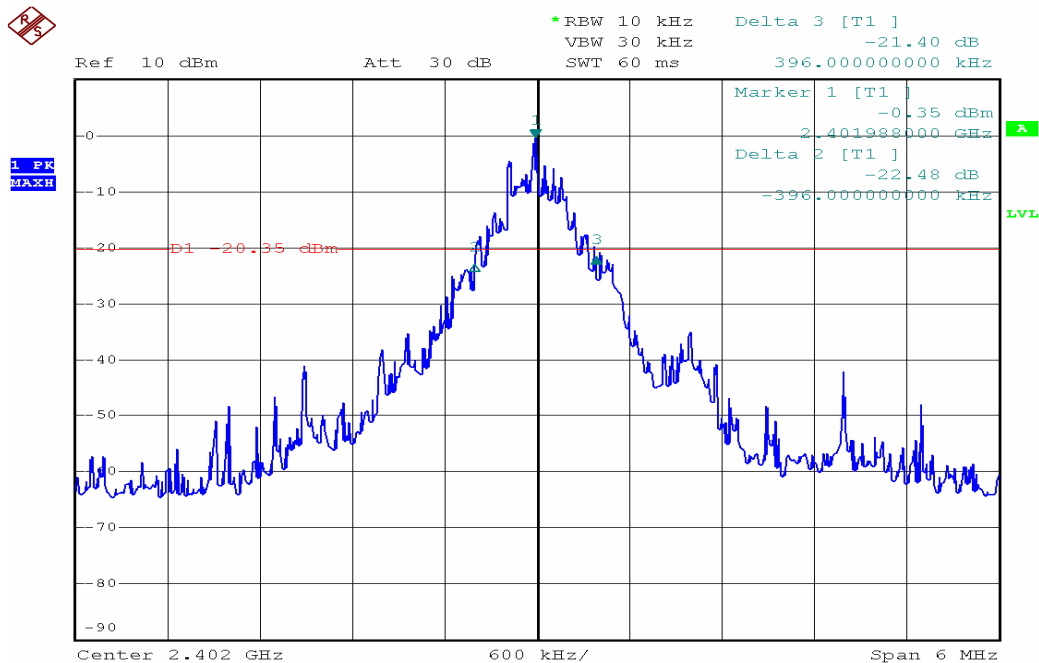

Date: 18.MAY.2007 11:17:04



Channel 39:

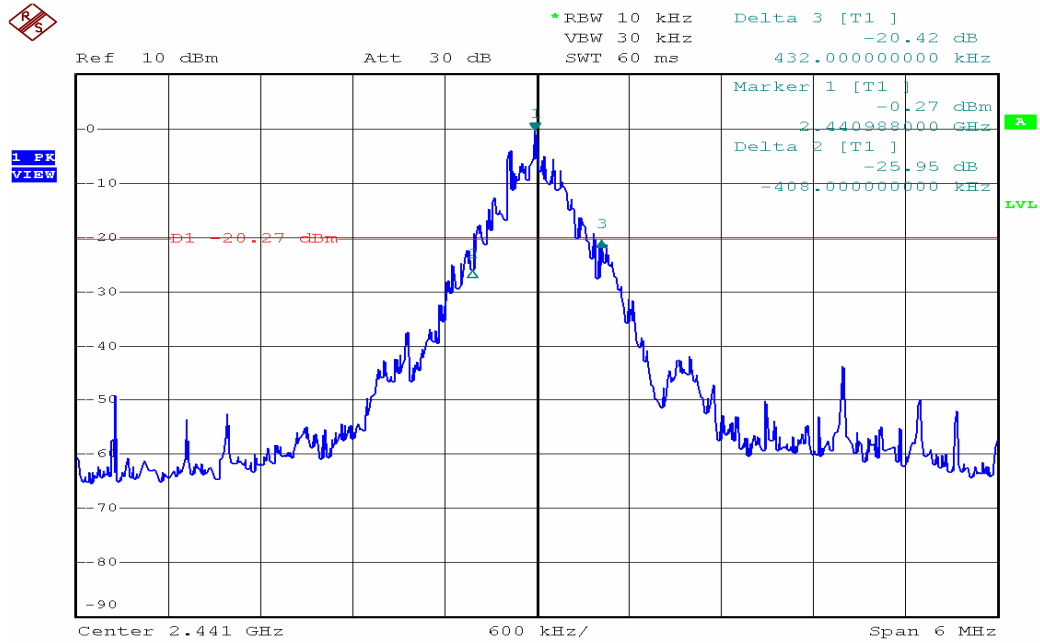

Date: 18.MAY.2007 11:13:59

Channel 78:

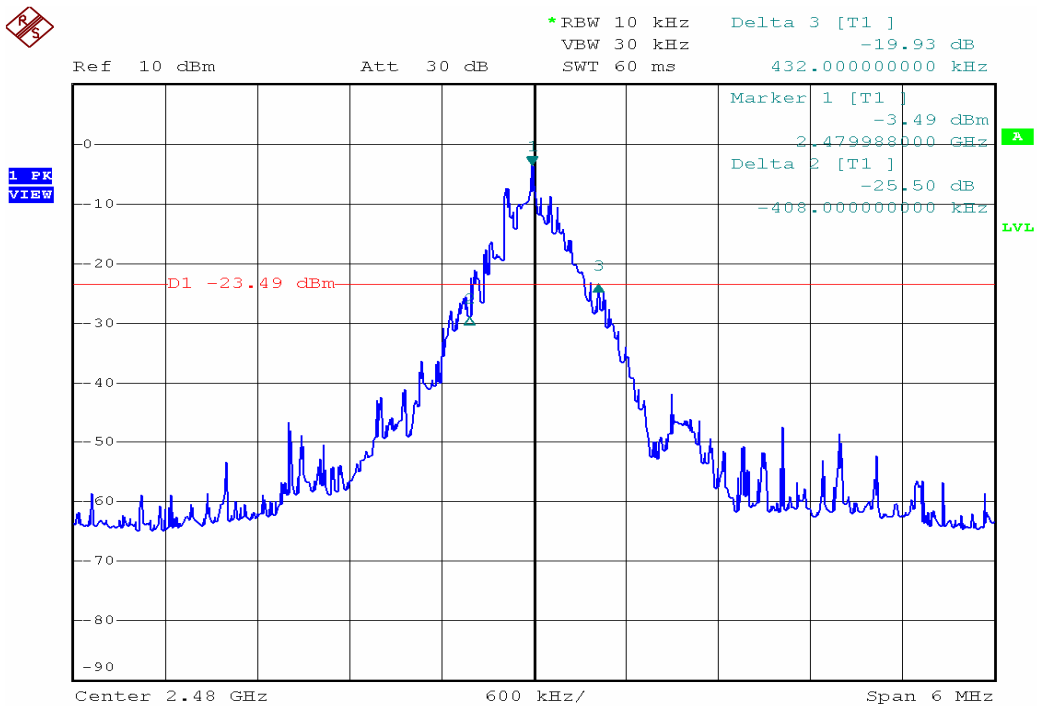

Date: 18.MAY.2007 11:12:16



### 6.10 Carrier Frequencies Separated

Test Requirement: FCC Part 15 C  
Test Method: Based on FCC Part15 C Section 15.247:  
Test Date: 18 May 2007  
Test requirements: Regulation 15.247(a)(1) Frequency hopping systems shall have hopping channel carrier frequencies separated by a minimum of 25 kHz or the 20 dB bandwidth of the hopping channel, whichever is greater. Alternatively, frequency hopping systems operating in the 2400-2483.5 MHz band may have hopping channel carrier frequencies that are separated by 25 kHz or two-thirds of the 20 dB bandwidth of the hopping channel, whichever is greater, provided the systems operate with an output power no greater than 125 mW.

Test Procedure:

1. Remove the antenna from the EUT and then connect a low RF cable from the antenna port to the spectrum.
2. Set the spectrum analyzer: RBW  $\geq$  1% of the span (set 100KHz), VBW  $\geq$  RBW (set 300KHz), Span = 10MHz, Sweep = auto; Detector Function = Peak (Max. hold).
3. Mark the peak frequency and -20dB.

Test result:

Test Channel	Carrier Frequencies Separated	Limit	Verdict
Lower Channels (channel 0 and channel 1)	1.008MHz	>20dBm Occupied bandwidth	Pass
Middle Channels (channel 39 and channel 40)	1.008MHz		Pass
Middle Channels (channel 38 and channel 39)	1.044MHz		Pass
Upper Channels (channel 77 and channel 78)	1.008MHz		Pass



Channel 0:

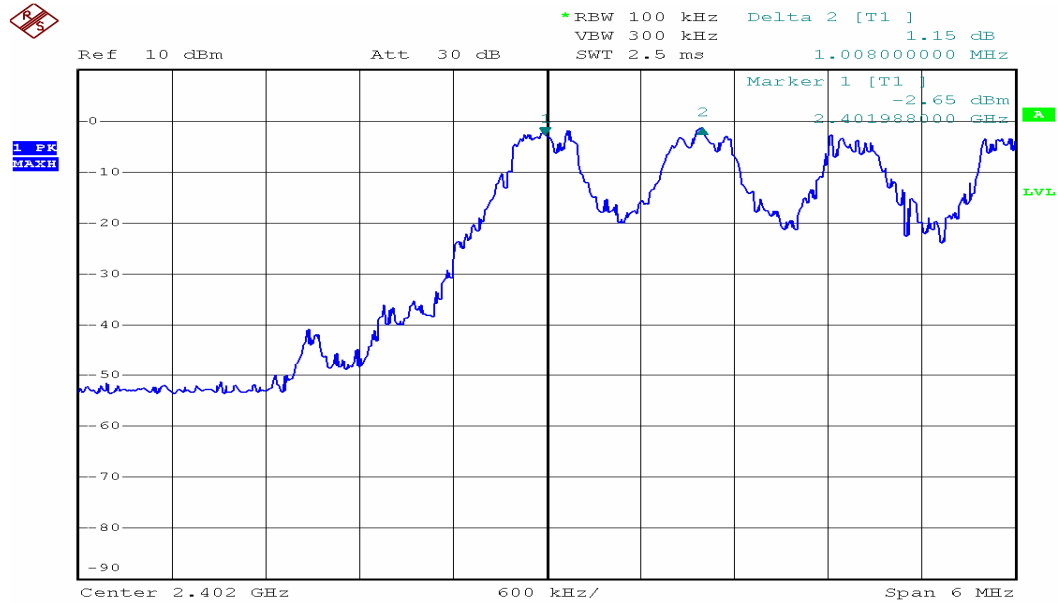

Date: 18.MAY.2007 11:48:10

Channel 39:

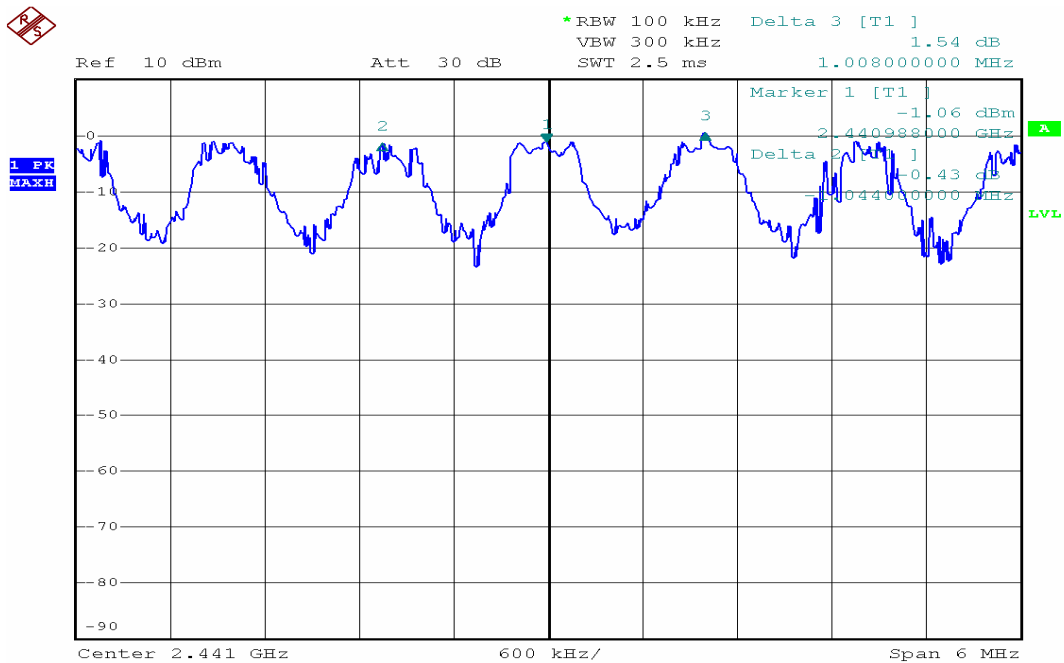

Date: 18.MAY.2007 11:46:00



Channel 78:

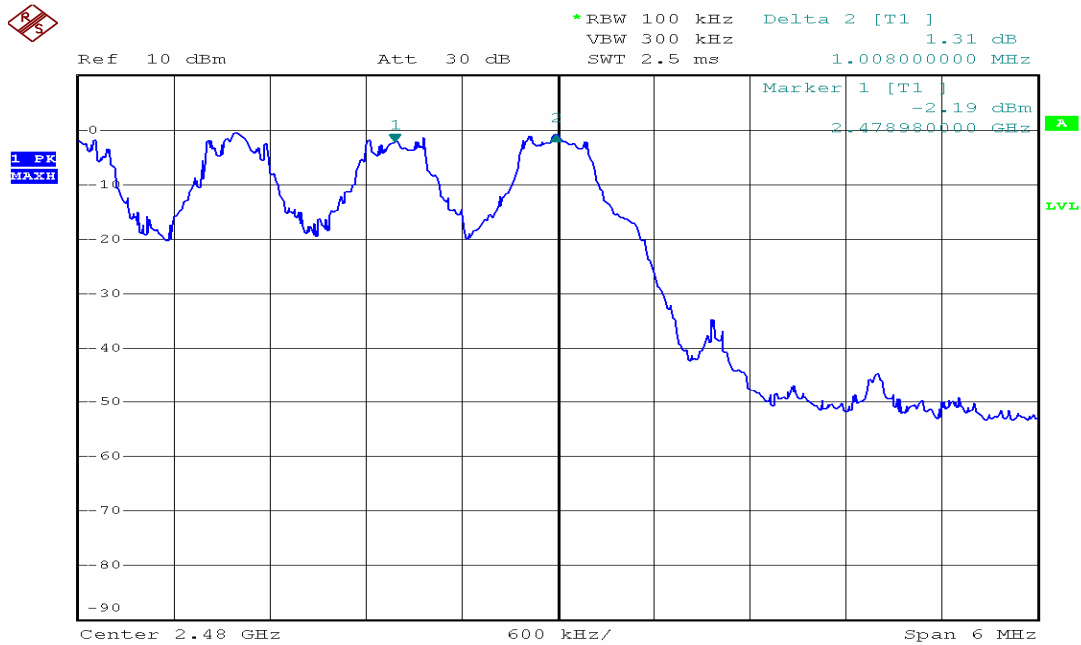

Date: 18.MAY.2007 11:44:26



## 6.11 Dwell Time

Test Requirement:	FCC Part 15 C
Test Method:	Based on FCC Part15 C Section 15.247:
Test Date:	18 May 2007
Test requirements:	Regulation 15.247(a)(1)(iii) Frequency hopping systems in the 2400-2483.5 MHz band shall use at least 15 channels. The average time of occupancy on any channel shall not be greater than 0.4 seconds within a period of 0.4 seconds multiplied by the number of hopping channels employed. Frequency hopping systems may avoid or suppress transmissions on a particular hopping frequency provided that a minimum of 15 channels are used.

### Test Procedure:

1. Remove the antenna from the EUT and then connect a low RF cable from the antenna port to the spectrum.
2. Set RBW of spectrum analyzer to 1MHz and VBW of spectrum analyzer to 1MHz, Set the test channel frequency span to 0.

### Test Result:

The test period:  $T = 0.4 \text{ Second/Channel} \times 79 \text{ Channel} = 31.6 \text{ s}$

#### 1. Channel 0: 2.402GHz

$$\text{DH1 time slot} = 0.420 \text{ (ms)} * (1600/(2*79)) * 31.6 = 134.400 \text{ ms}$$

$$\text{DH3 time slot} = 1.672 \text{ (ms)} * (1600/(4*79)) * 31.6 = 267.520 \text{ ms}$$

$$\text{DH5 time slot} = 2.940 \text{ (ms)} * (1600/(6*79)) * 31.6 = 313.600 \text{ ms}$$

#### 2. Channel 39: 2.441GHz

$$\text{DH1 time slot} = 0.415 \text{ (ms)} * (1600/(2*79)) * 31.6 = 132.800 \text{ ms}$$

$$\text{DH3 time slot} = 1.672 \text{ (ms)} * (1600/(4*79)) * 31.6 = 267.520 \text{ ms}$$

$$\text{DH5 time slot} = 2.940 \text{ (ms)} * (1600/(6*79)) * 31.6 = 313.600 \text{ ms}$$

#### 3. Channel 78: 2.4835GHz

$$\text{DH1 time slot} = 0.420 \text{ (ms)} * (1600/(2*79)) * 31.6 = 134.400 \text{ ms}$$

$$\text{DH3 time slot} = 1.672 \text{ (ms)} * (1600/(4*79)) * 31.6 = 267.520 \text{ ms}$$

$$\text{DH5 time slot} = 2.940 \text{ (ms)} * (1600/(6*79)) * 31.6 = 313.600 \text{ ms}$$

The results are not be greater than 0.4 seconds.

**The unit does meet the FCC requirements.**

Please refer the graph as below:



1. Lowest channel (2.402 GHz):

(1). DH1

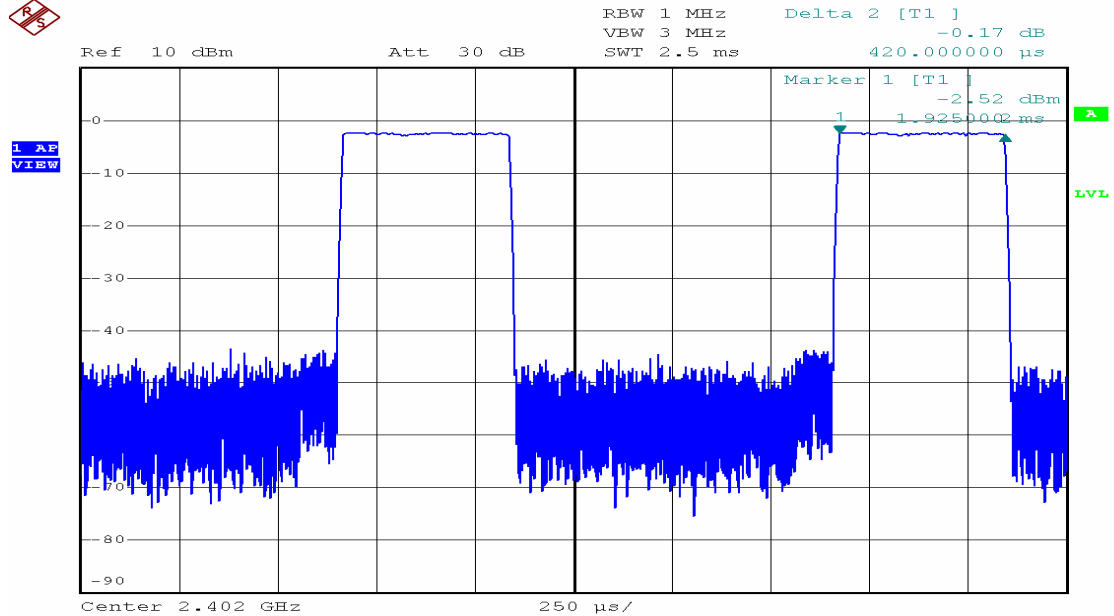

Date: 18.MAY.2007 11:22:25

(2) DH3:

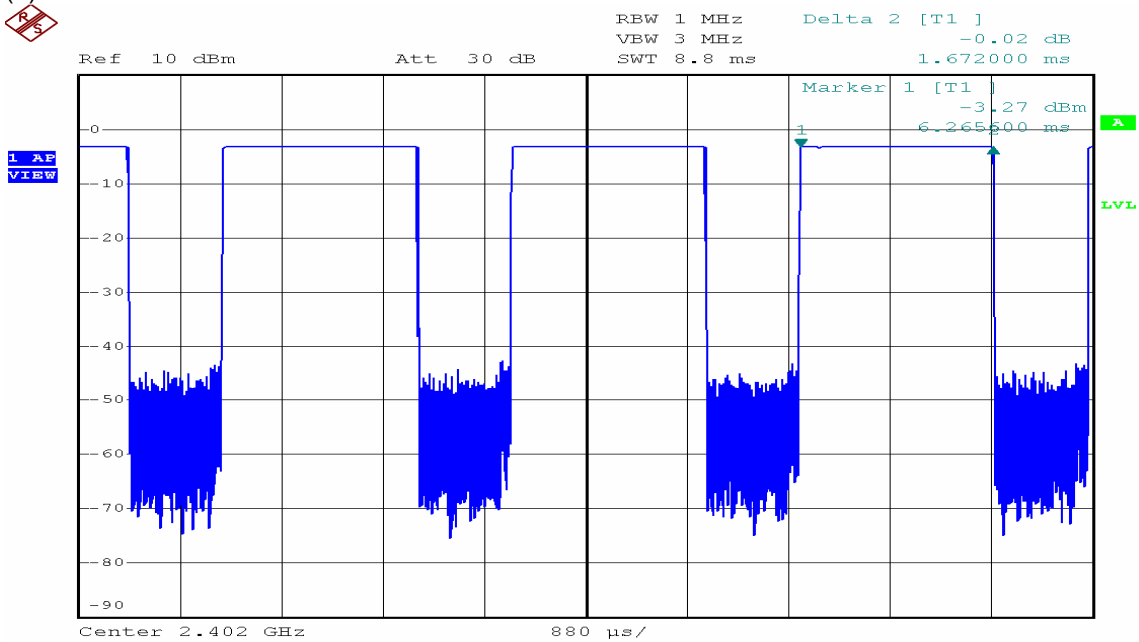

Date: 18.MAY.2007 11:25:46





1. Lowest channel (2.402 GHz):

(3). DH5:

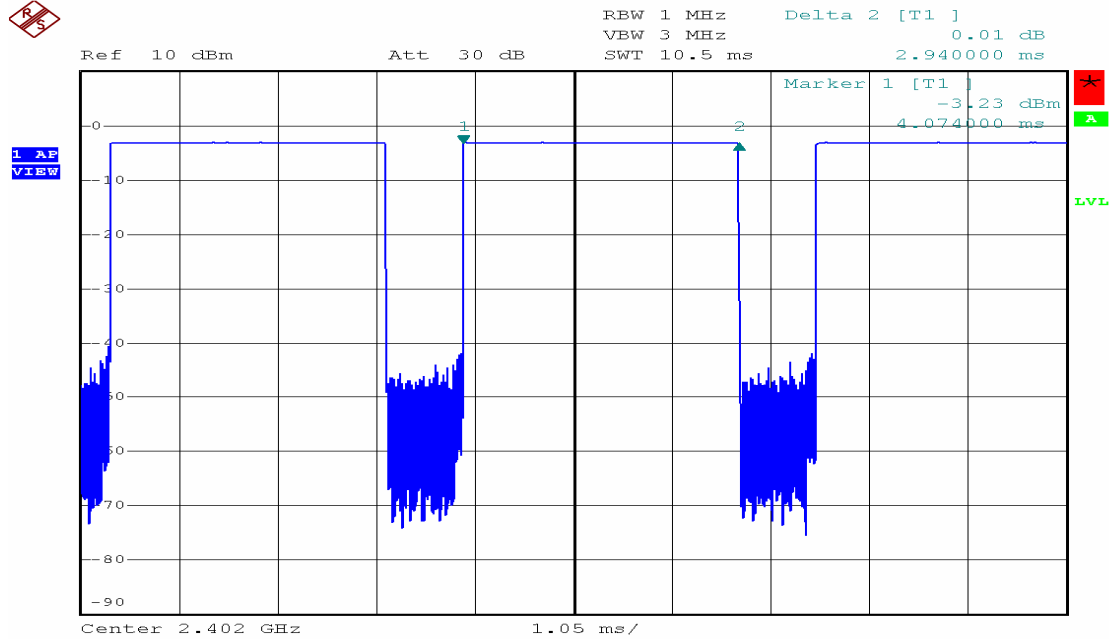

Date: 18.MAY.2007 11:35:20

2. Middle Channel (2.441GHz)

(1) DH1

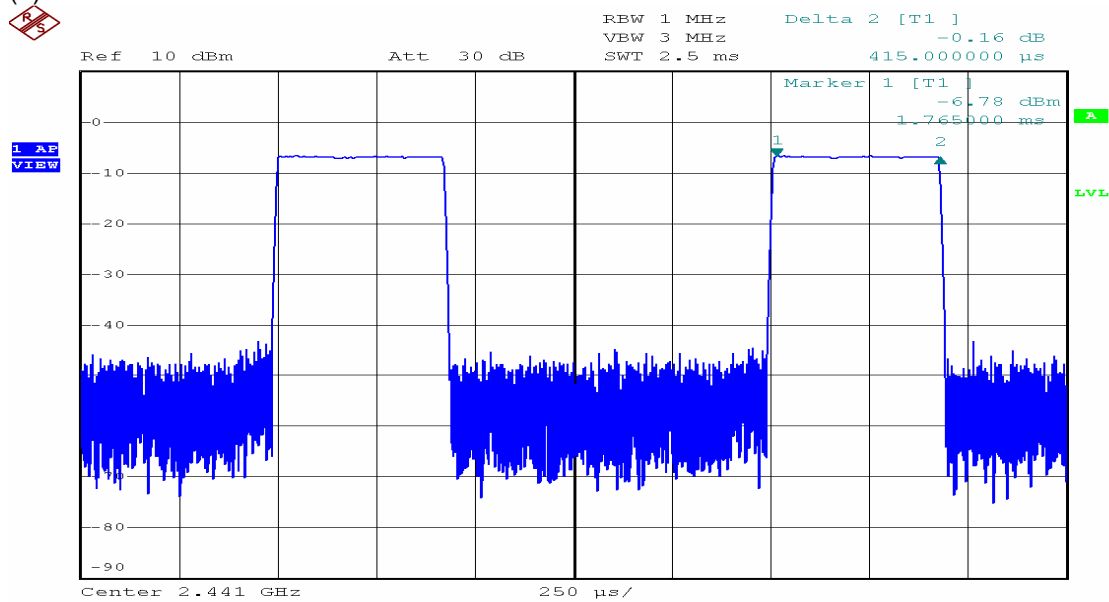

Date: 18.MAY.2007 11:23:26



2. Middle Channel (2.441GHz)

(2) DH3

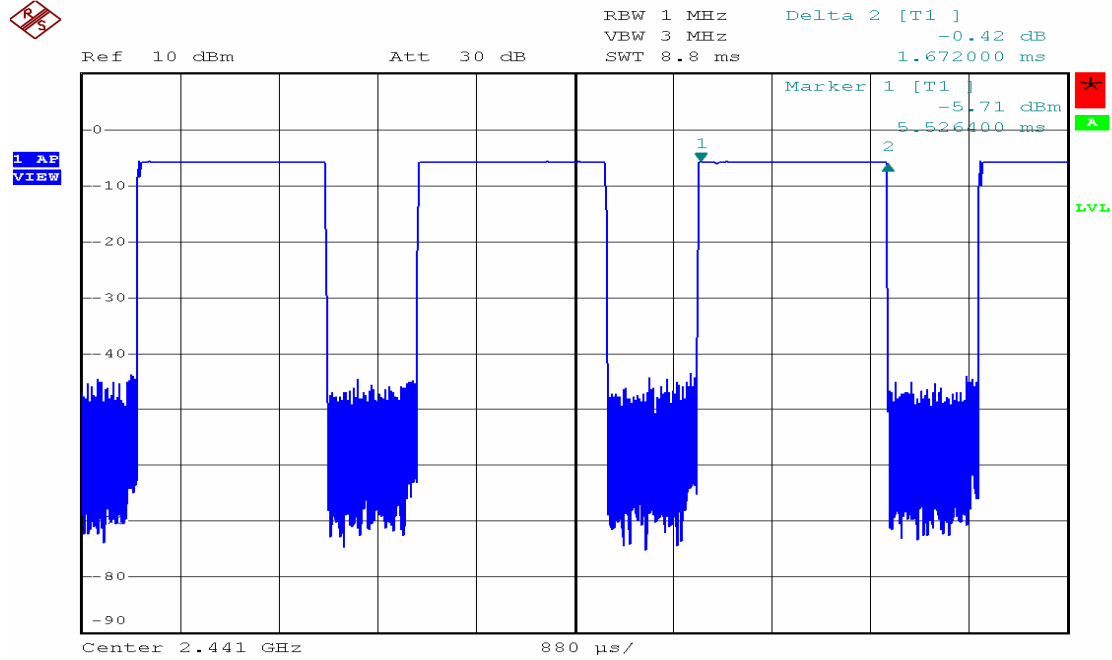

Date: 18.MAY.2007 11:31:21

(3) DH5

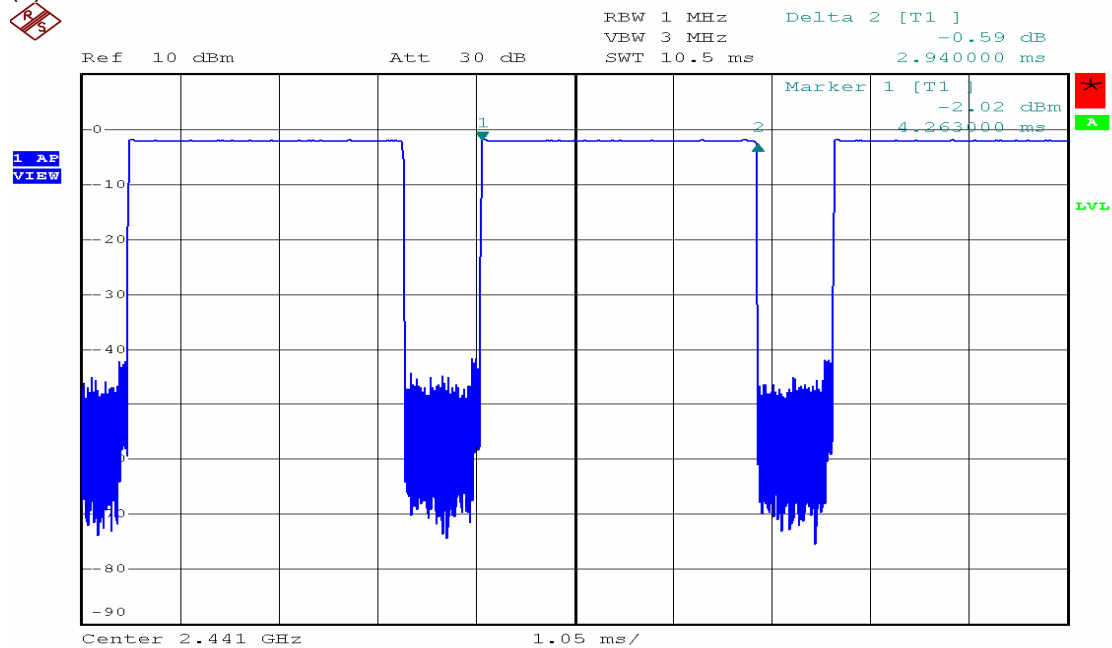

Date: 18.MAY.2007 11:34:25



3. Highest channel (2.480GHz)

(1). DH1

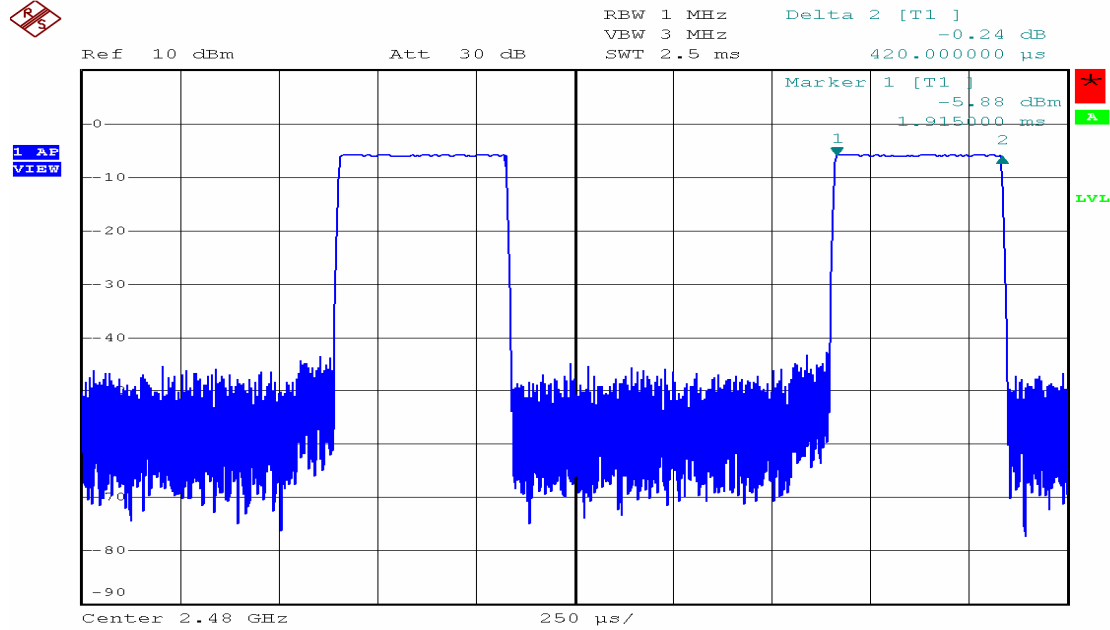

Date: 18.MAY.2007 11:24:14

(2). DH3

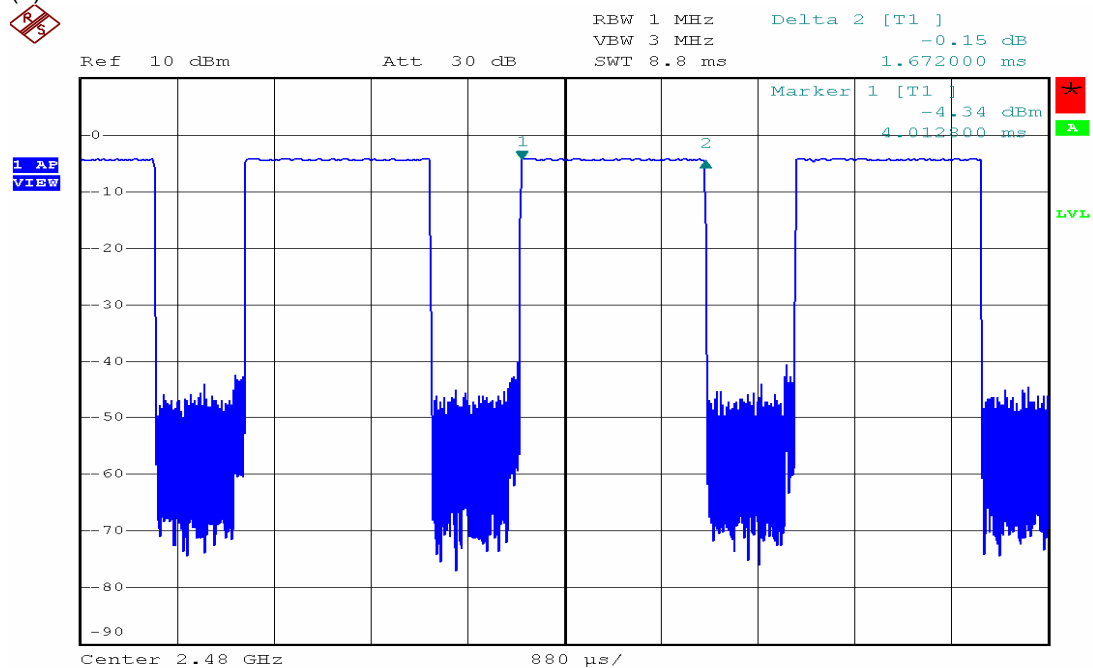

Date: 18.MAY.2007 11:32:05



3. Highest channel (2.480GHz)

(3). DH5

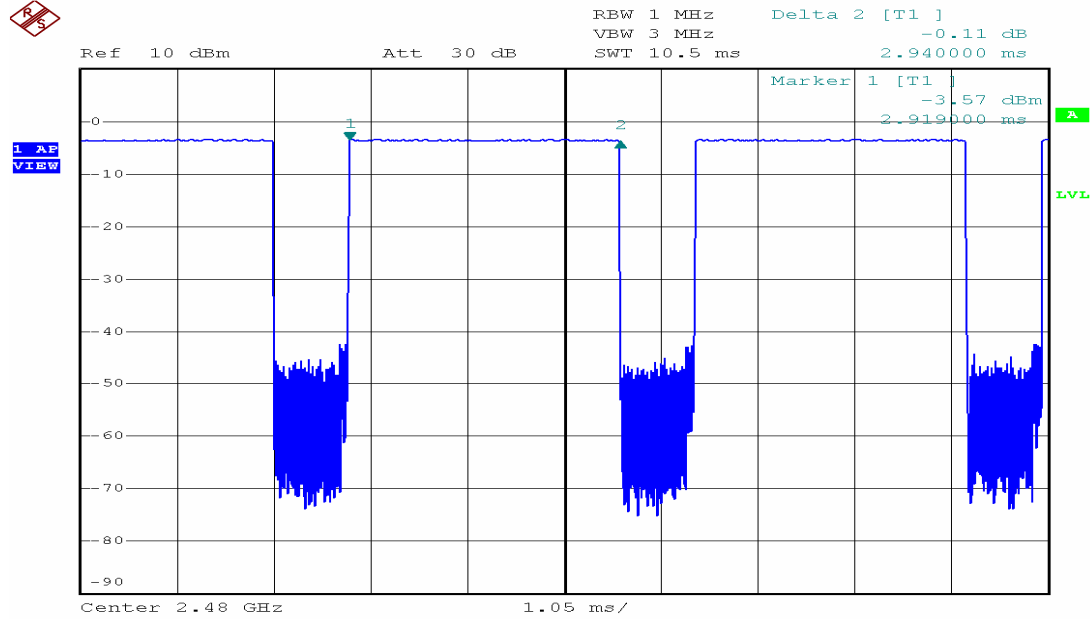

Date: 18.MAY.2007 11:33:34



## **6.12 Antenna Requirement**

### **6.12.1 Standard Applicable**

For intentional device, according to 15.203, an intentional radiator shall be designed to ensure that no antenna other than that furnished by the responsible party shall be used with the device.

Regulation 15.247(c) (1)(i) Systems operating in the 2400-2483.5 MHz band that are used exclusively for fixed, point-to-point operations may employ transmitting antennas with directional gain greater than 6 dBi provided the maximum conducted output power of the intentional radiator is reduced by 1 dB for every 3 dB that the directional gain of the antenna exceeds 6 dBi.

### **6.12.2 Antenna Construction**

The antenna is integrated on the main PCB and no consideration of replacement.