

FCC RADIO TEST REPORT

For
FCC ID: BOOSE-ET8

Report Reference No..... : 18EEFAS09026 31

Date of issue : 2018-09-29

Testing Laboratory : DongGuan ShuoXin Electronic Technology Co., Ltd.

Address..... : Zone A, 1F, No. 6, XinGang Road YuanGang Street, XinAn
District, ChangAn Town, DongGuan City, GuangDong,
China

Applicant's name..... : Unisen Limited

Address..... : Room 907, Fook Hong Industrial Bldg., 19 Sheung Yuet
Road, KowloonBay, Kowloon, Hong Kong

Manufacturer..... : Unisen Limited

Test specification:

Test item description..... : 8" Android Tablet

Trade Mark..... :

Model/Type reference..... : SE-ET8

Ratings..... : I/P: DC 3.8V/4000mAh Li-ion Battery

Responsible Engineer :

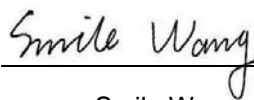

Smile Wang

Authorized Signatory:

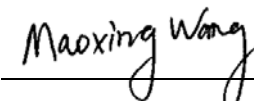

King Wang

TABLE OF CONTENTS

1. Summary of test Standards and results.....	4
2.1. Description of EUT	5
2.2. Accessories of EUT	5
2.3. Assistant equipment used for test.....	5
2.4. Block diagram of EUT configuration for test.....	6
2.5. Test environment conditions	6
2.6. Measurement uncertainty	7
3. 6dB Bandwidth and 99% Occupied Bandwidth	8
3.1. Test equipment	8
3.2. Block diagram of test setup.....	8
3.3. Limits	8
3.4. Test Procedure.....	8
3.. Test Result.....	9
3.6. Original test data.....	10
4. Maximum Peak Output Power	16
4.1. Test equipment	16
4.2. Block diagram of test setup.....	16
4.3. Limits	16
4.4. Test Procedure.....	16
5. Power Spectral Density.....	18
5.1. Test equipment	18
5.2. Block diagram of test setup.....	18
5.3. Limits	18
5.5. Test Result.....	19
5.6. Original test data.....	20
6. Spurious Emissions	26
6.1. Test equipment	26
6.2. Block diagram of test setup.....	27
6.3. Limit	28
7. 100 kHz Bandwidth of Frequency Band Edge.....	55
7.1. Test equipment	55
7.2. Block diagram of test setup.....	55
7.3. Limit	55
7.4. Test Procedure.....	56
7.5. Test result	56

8. Conducted Spurious Emissions.....	62
8.1. Test Equipment.....	62
8.2. Limit	62
8.3. Test Procedure.....	62
8.4. Test result	63
9 Power Line Conducted Emission.....	69
9.1 Test equipment.....	69
9.2 Block diagram of test setup.....	69
9.3 Power Line Conducted Emission Limits(Class B).....	69
9.4 Test Procedure.....	70
9.5 Test Result.....	70
10. Antenna Requirements	73
10.1. Limit	73
10.2. Result	73

TEST REPORT DECLARE

Applicant	:	Unisen Limited
Address	:	Room 907, Fook Hong Industrial Bldg., 19 Sheung Yuet Road, Kowloon Bay, Kowloon, Hong Kong
Equipment under Test	:	8" Android Tablet
Test Model No	:	SE-ET8
Manufacturer	:	Unisen Limited
Address	:	NO.1, Wuwu Road, BanShi Wuwu Village, Changping Town, Dongguan City Guangdong Prov. China

Test Standard Used: FCC Rules and Regulations Part 15 Subpart C (15.247)

Test procedure used: ANSI C63.10:2013, 558074 D01 15.247 Meas Guidance v05.

We Declare:

The equipment described above is tested by DongGuan ShuoXin Electronic Technology Co., Ltd. and in the configuration tested the equipment complied with the standards specified above. The test results are contained in this test report and DongGuan ShuoXin Electronic Technology Co., Ltd. is assumed of full responsibility for the accuracy and completeness of these tests.

After test and evaluation, our opinion is that the equipment provided for test compliance with the requirement of the above FCC standards.

Report No:	18EEFAS09026 11		
Date of Test:	2018-09-15 To 2018-09-27	Date of Report:	2018-09-29

Note: This report applies to above tested sample only. This report shall not be reproduced in parts without written approval of DongGuan ShuoXin Electronic Technology Co., Ltd.

1. Summary of test Standards and results

The EUT have been tested according to the applicable standards as referenced below.

Description of Test Item	Standard	Results
6dB Bandwidth And 99% Occupied Bandwidth	FCC Part 15.247 (a)(2)	PASS
Peak Output Power	FCC Part 15.247(b)(3)	PASS
Power Spectral Density	FCC Part 15.247(e)	PASS
Spurious Emissions at Antenna Port	FCC Part 15.247(d)	PASS
Spurious Emissions	FCC Part 15.205, 15.209, FCC Part 15.247(d)	PASS
100 kHz Bandwidth of Frequency Band Edge	FCC Part 15.247(d)	PASS
AC Line Conducted Emissions	FCC Part 15.207 (a)	PASS
Antenna requirement	FCC Part 15: 15.203	PASS

2. GENERAL TEST INFORMATION

2.1. Description of EUT

EUT* Name	:	8" Android Tablet
Model Number	:	SE-ET8
Trade Mark	:	
EUT function description	:	Please reference user manual of this device
Power supply	:	DC3.8V/4000mAh
Adaptor	:	100V-240Vac 50/60Hz 0.8A
Radio Specification	:	IEEE802.11b/g/n20/n40
Operation frequency	:	IEEE 802.11b: 2412MHz—2462MHz IEEE 802.11g: 2412MHz—2462MHz IEEE 802.11n20: HT20: 2412MHz—2462MHz IEEE 802.11n40: HT40: 2422MHz—2452MHz
Modulation	:	IEEE 802.11b: DSSS(CCK,DQPSK,DBPSK) IEEE 802.11g: OFDM(64QAM, 16QAM, QPSK, BPSK) IEEE 802.11n20: HT20: OFDM (64QAM, 16QAM, QPSK,BPSK) IEEE 802.11n40: HT40: OFDM (64QAM, 16QAM, QPSK,BPSK)
Antenna Type	:	Internal Antenna, maximum PK gain: 1dBi
FVIN	:	NA
Date of Receipt	:	2018/09/15
Sample Type	:	Series production

Note: EUT is the ab. of equipment under test.

2.2. Accessories of EUT

Description of Accessories	Manufacturer	Model number or Type	Other
/	/	/	/

2.3. Assistant equipment used for test

Description of Assistant equipment	Manufacturer	Model number or Type	Other

2.4. Block diagram of EUT configuration for test



EUT enters the engineering interface by clicking the system version. The Transmit duty cycle was set to 100%.

Tested mode, channel, and data rate information			
Mode	data rate (Mbps) (see Note)	Channel	Frequency (MHz)
IEEE 802.11b	1	Low :CH1	2412
	1	Middle: CH6	2437
	1	High: CH11	2462
IEEE 802.11g	6	Low :CH1	2412
	6	Middle: CH6	2437
	6	High: CH11	2462
IEEE 802.11n HT20	MCS 0	Low :CH1	2412
	MCS 0	Middle: CH6	2437
	MCS 0	High: CH11	2462
IEEE 802.11n HT40	MCS 0	Low :CH3	2422
	MCS 0	Middle: CH6	2437
	MCS 0	High: CH9	2452

Note: According exploratory test, EUT will have maximum output power in those data rate, so those data rate were used for all test.

2.5. Test environment conditions

During the measurement the environmental conditions were within the listed ranges:

Temperature range:	21-25°C
Humidity range:	40-75%
Pressure range:	86-106kPa

2.6. Measurement uncertainty

Test Item	Uncertainty
Uncertainty for Conduction emission test (9kHz-150kHz)	3.7 dB
Uncertainty for Conduction emission test (150kHz-30MHz)	3.3 dB
Uncertainty for Radiation Emission test (30MHz-200MHz)	4.60 dB (Polarize: V)
	4.60 dB (Polarize: H)
Uncertainty for Radiation Emission test (200MHz-1GHz)	6.10 dB (Polarize: V)
	5.08 dB (Polarize: H)
Uncertainty for Radiation Emission test (1GHz-6GHz)	5.01 dB (Polarize: V)
	5.01 dB (Polarize: H)
Uncertainty for Radiation Emission test (6GHz-18GHz)	5.26 dB (Polarize: V)
	5.26 dB (Polarize: H)
Uncertainty for Radiation Emission test (18GHz-40GHz)	5.06 dB (Polarize: V)
	5.06 dB (Polarize: H)
Uncertainty for radio frequency	$\pm 0.048\text{kHz}$
Uncertainty for conducted RF Power	$\pm 0.32\text{dB}$

Note: This uncertainty represents an expanded uncertainty expressed at approximately the 95% confidence level using a coverage factor of k=2.

3. 6dB Bandwidth and 99% Occupied Bandwidth

3.1. Test equipment

Item	Equipment	Manufacturer	Model No.	Serial No.	Calibrated until	Calibrated Date
1	Spectrum analyzer	KEYSIGHT	N9010A	MY55150427	05/25/2019	05/26/2018
2	Attenuator	Mini-Circuits	BW-S10W2	101109	12/17/2018	12/18/2017
3	RF Cable	Micable	C10-01-01-1	100309	12/17/2018	12/18/2017

3.2. Block diagram of test setup

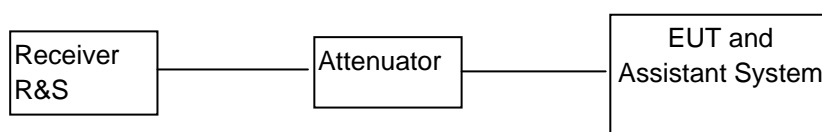

3.3. Limits

For direct sequence systems, the minimum 6dB bandwidth shall be at least 500 KHz

3.4. Test Procedure

- (1) Check the calibration of the measuring instrument using either an internal calibrator or a known signal from an external generator.
- (2) Position the EUT without connection to measurement instrument. Turn on the EUT and connect it to measurement instrument. Then set it to any one convenient frequency within its operating range. Set a reference level on the measuring instrument equal to the highest peak value.
- (3) Measure the frequency difference of two frequencies that were attenuated 6 dB from the reference level. Record the frequency difference as the emission bandwidth.
- (4) Repeat above procedures until all frequencies measured were complete.

3. Test Result

EUT Set Mode	CH or Frequency	6 dB bandwidth	99% dB bandwidth	Limt	Conclusion
		Result (MHz)	Result (MHz)		
IEEE 802.11B	CH 1	9.59	13.02	>500KHz	PASS
	CH 6	8.72	13.44		PASS
	CH 11	8.61	12.87		PASS
IEEE 802.11G	CH 1	16.58	17.55		PASS
	CH 6	14.11	19.86		PASS
	CH 11	13.18	16.50		PASS
IEEE 802.11N20	CH 1	17.75	17.82		PASS
	CH 6	10.21	17.78		PASS
	CH 11	14.26	17.46		PASS
IEEE 802.11N40	CH 3	12.86	35.07		PASS
	CH 6	14.36	35.59		PASS
	CH 9	36.38	36.26		PASS

3.6. Original test data

802.11 B Mode CH1

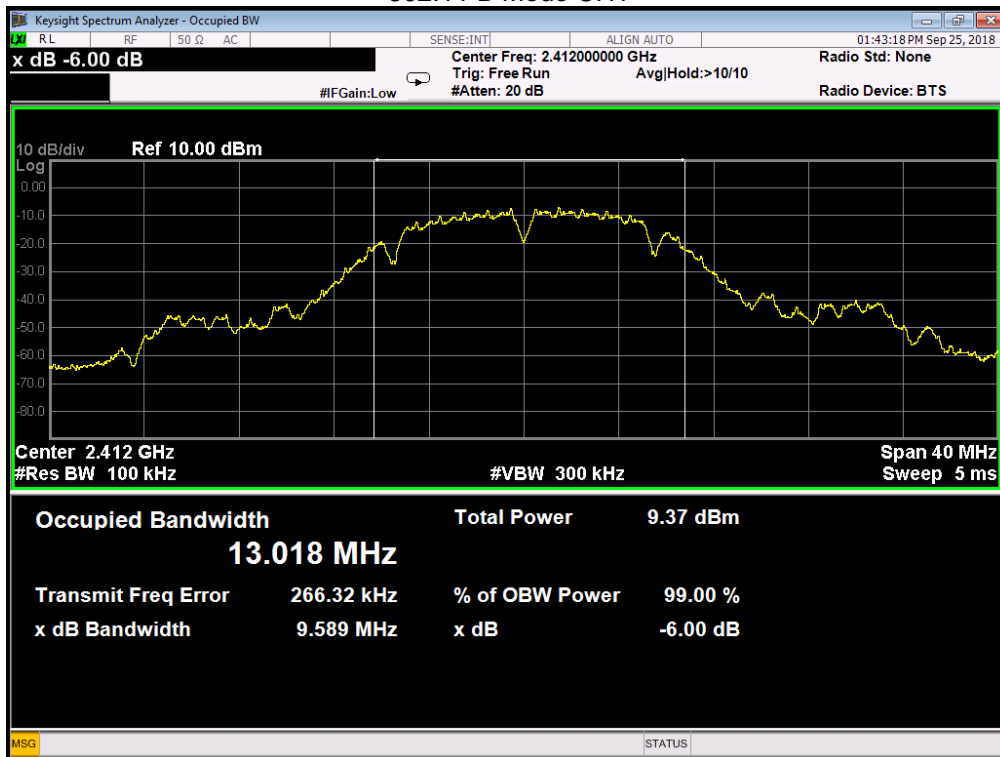

802.11 B Mode CH6

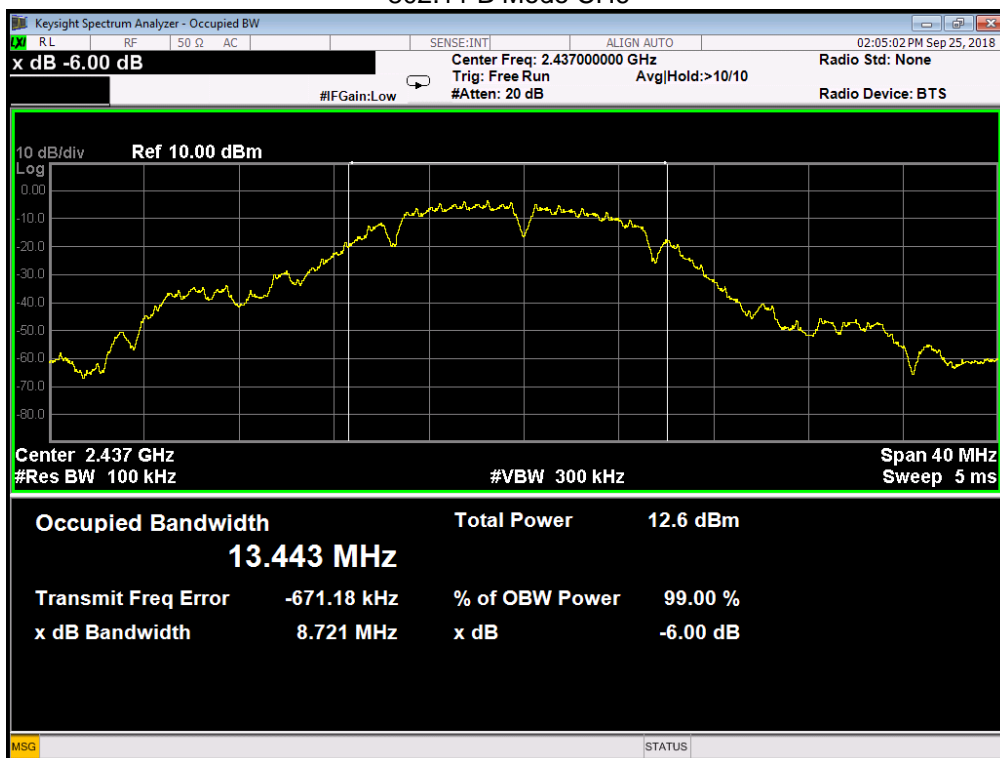

802.11 B Mode CH11

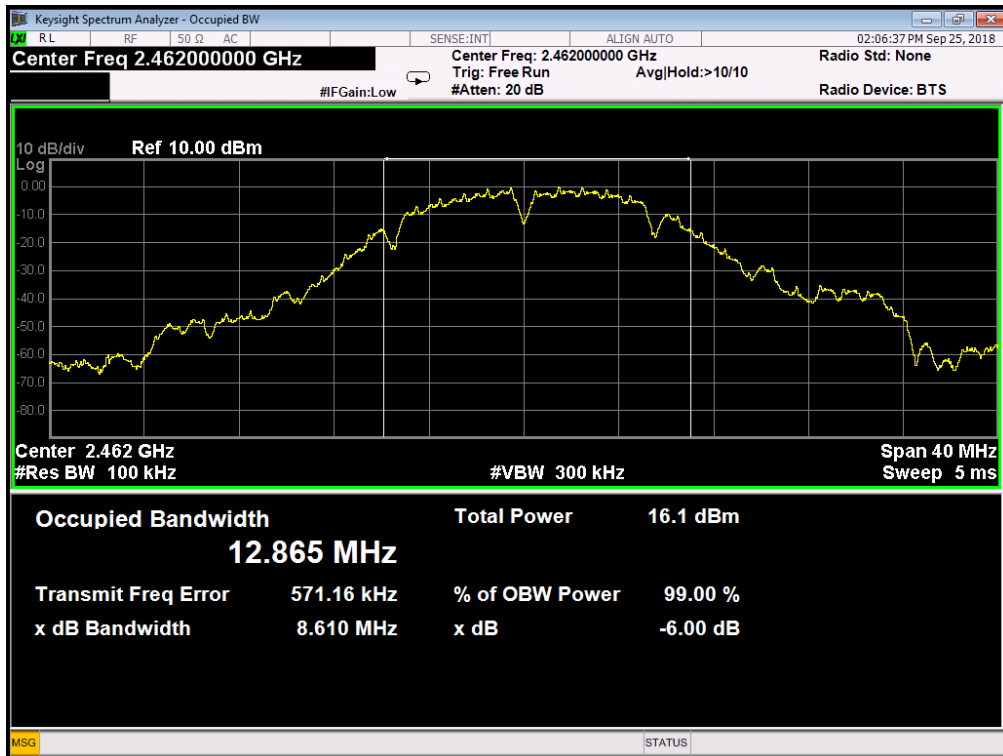

802.11 G Mode CH1

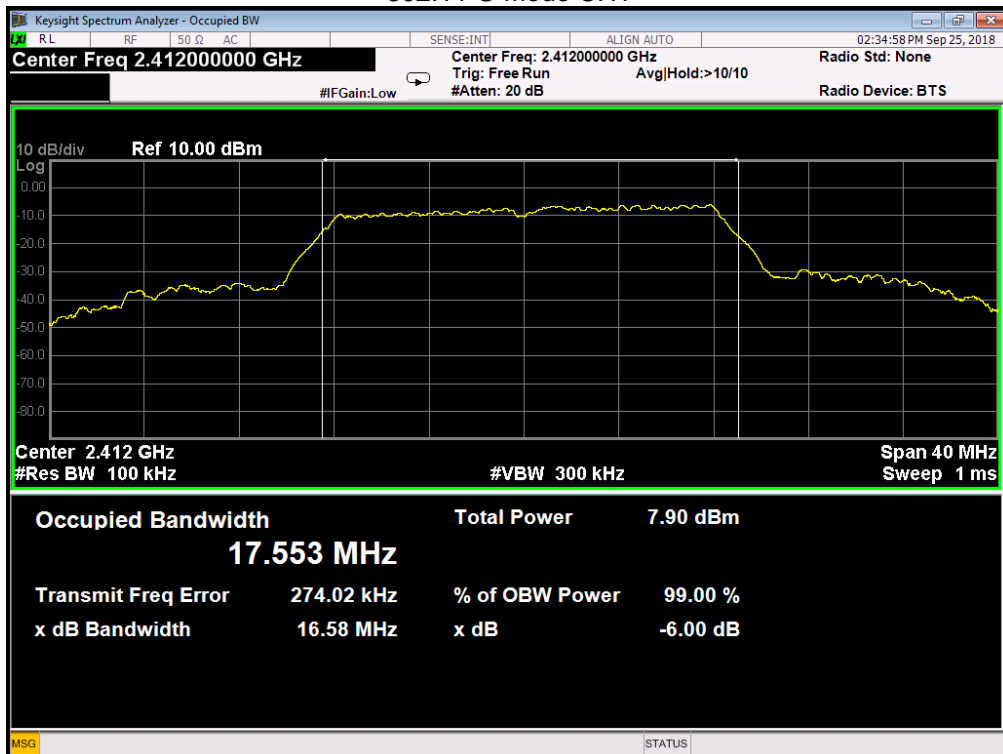

802.11 G Mode CH6

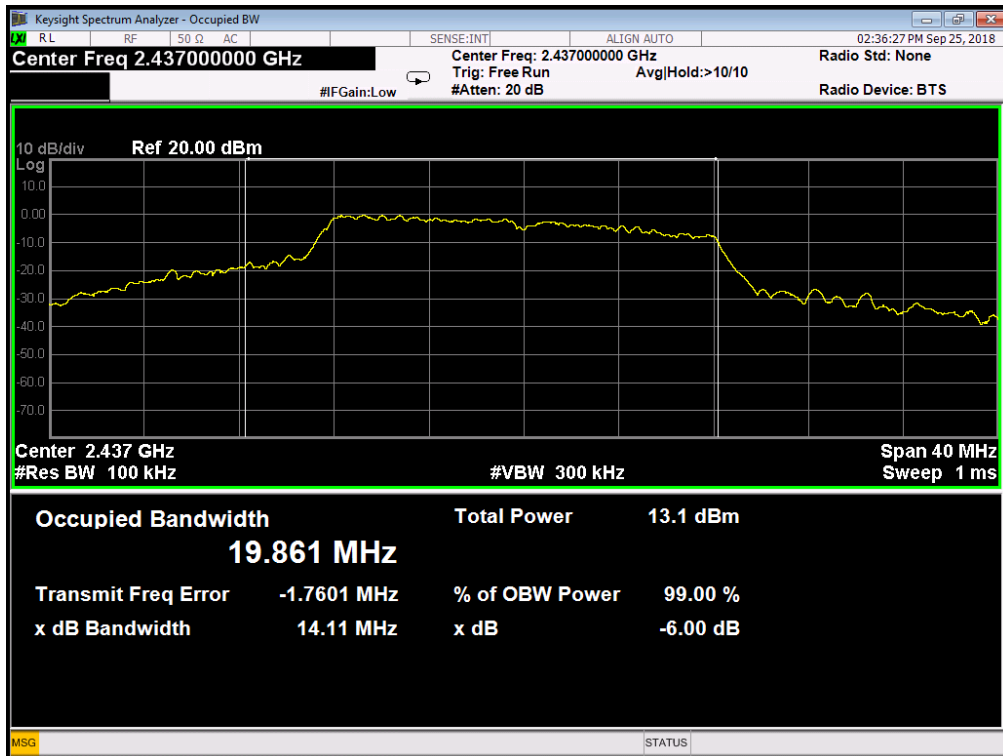

802.11 G Mode CH11

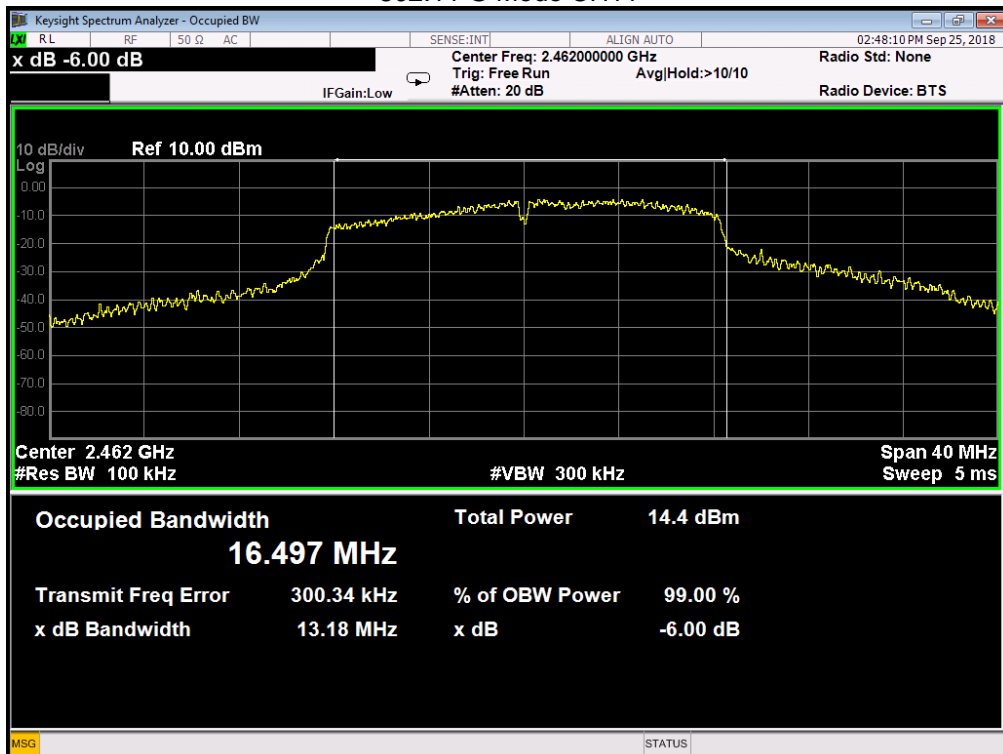

802.11 N20 Mode CH1

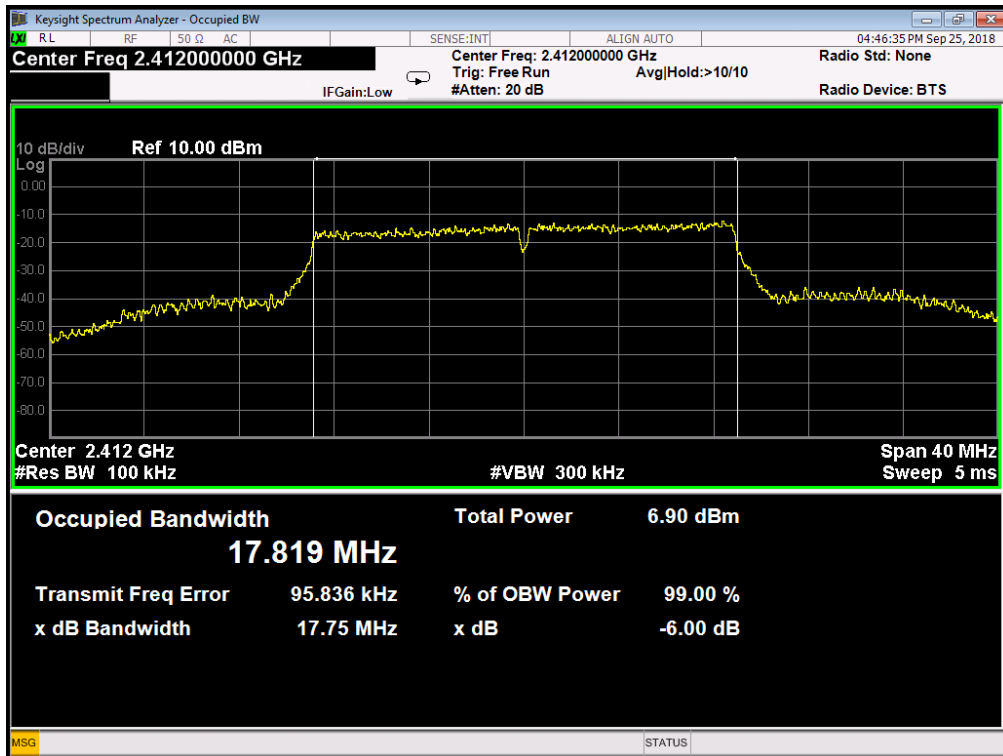

802.11 N20 Mode CH6

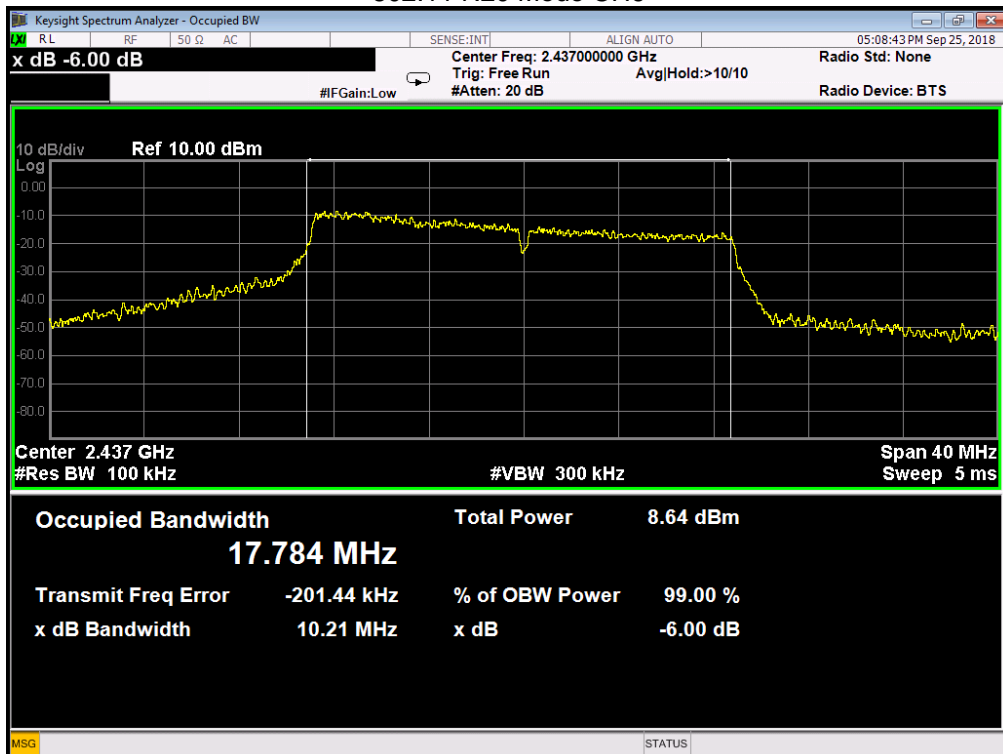

802.11 N20 Mode CH11

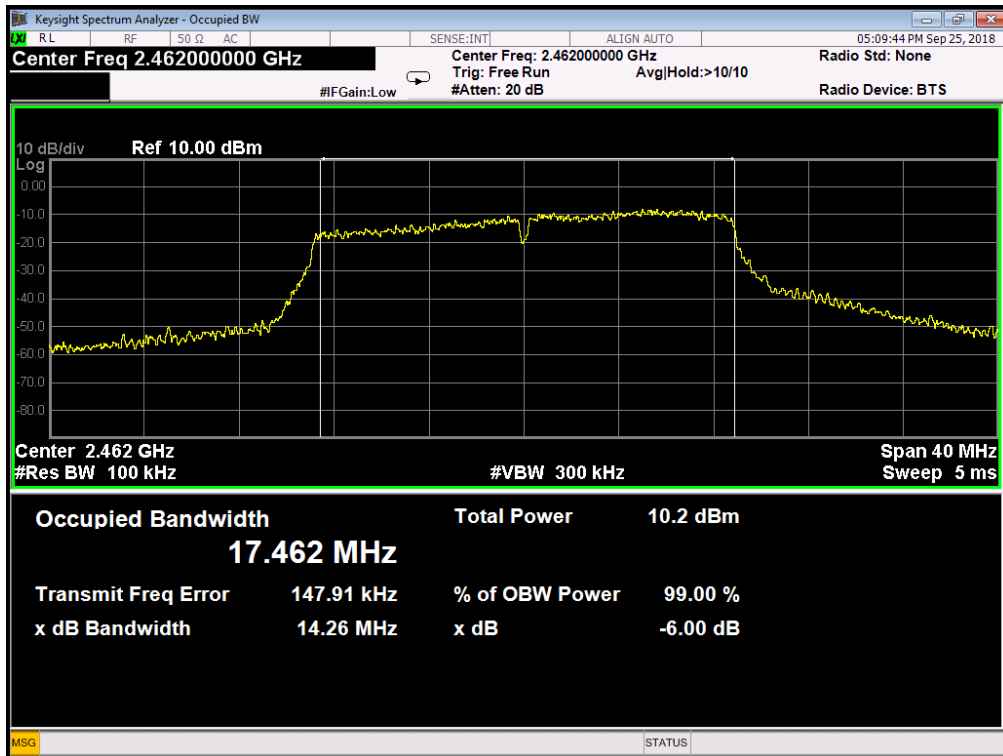

802.11 N40 Mode CH3

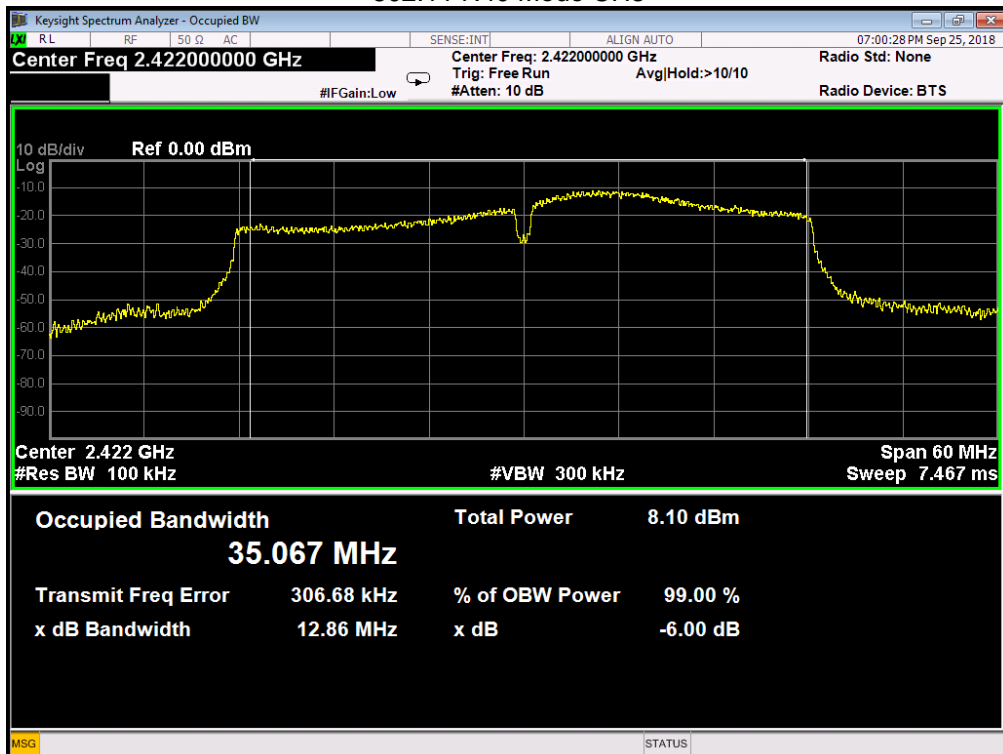

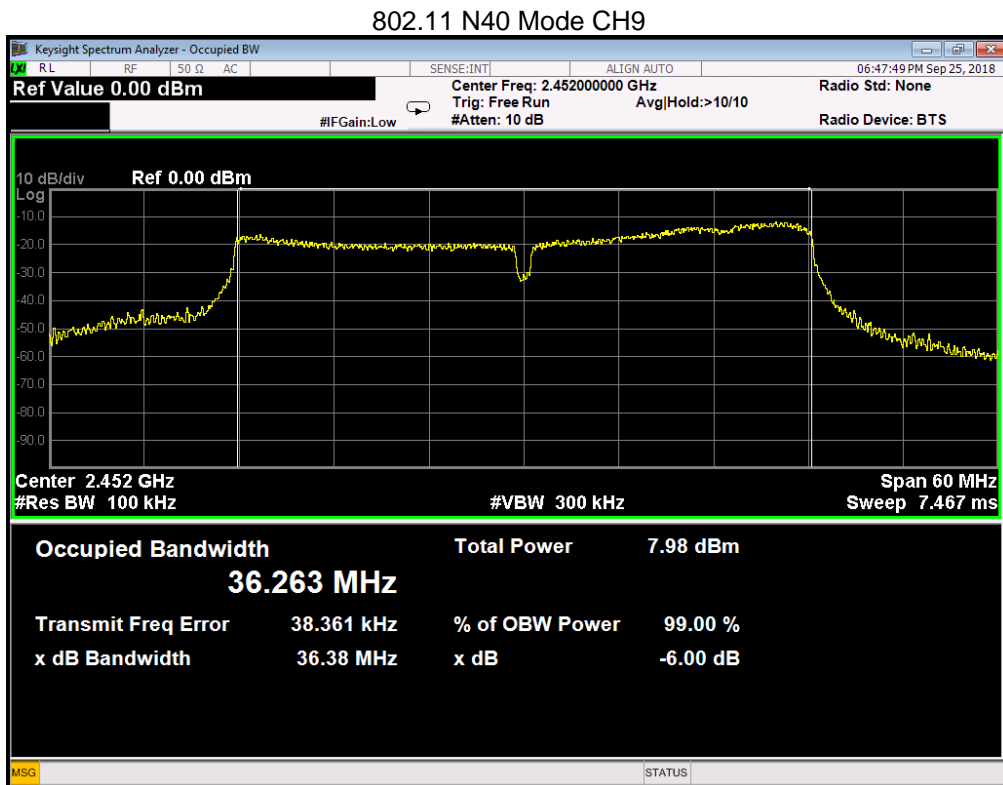
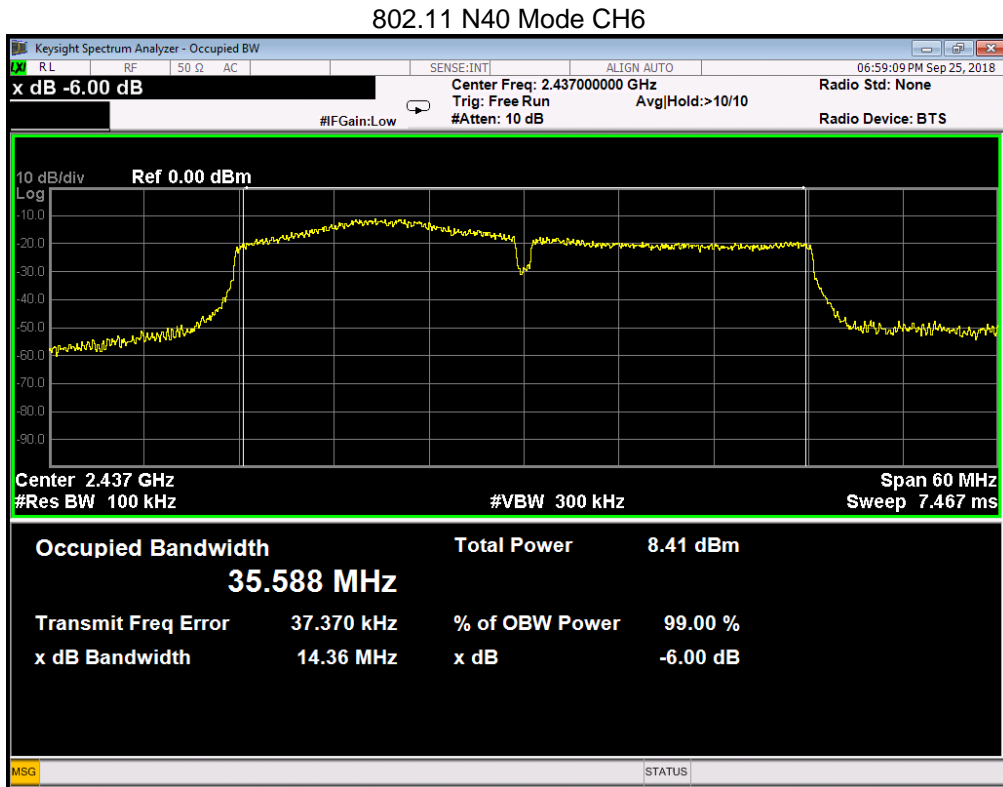

4. Maximum Peak Output Power

4.1. Test equipment

Item	Equipment	Manufacturer	Model No.	Serial No.	Calibrated until	Calibrated Date
1	Power meter	Agilent	E4417A	MY45100473	05/25/2019	05/26/2018
2	Wireband Power sensor	Agilent	E4427A	MY5100041	12/17/2018	12/18/2017
3	RF Cable	Micable	C10-01-01-1	100309	12/17/2018	12/18/2017

4.2. Block diagram of test setup

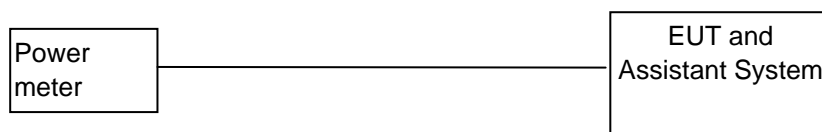

4.3. Limits

For systems using digital modulation in the 902-928 MHz, 2400-2483.5 MHz bands: 1 Watt. If transmitting antennas of directional gain greater than 6 dBi are used, the conducted output power from the intentional radiator shall be reduced below the stated values as appropriate, by the amount in dB that the directional gain of the antenna exceeds 6 dBi.

4.4. Test Procedure

1. Place the EUT on a bench and set it in transmitting mode.
2. A wide band power meter with a matched thermocouple detector was used to directly measure the output power from the RF output port of the EUT in continuously transmitting mode.
3. The measurement shall be repeated at the lowest, the middle, and the highest channel of the stated frequency range.

4.5. TEST RESULT

EUT Set Mode	CH	Result(dBm)	Total Power (dBm)	Limit	Conclusion
		Peak			
IEEE 802.11B	CH 1	8.67	/	30dBm	PASS
	CH 6	8.82	/	30dBm	PASS
	CH 11	8.36	/	30dBm	PASS
IEEE 802.11G	CH 1	8.38	/	30dBm	PASS
	CH 6	8.12	/	30dBm	PASS
	CH 11	8.43	/	30dBm	PASS
IEEE 802.11N20	CH 1	8.66	/	30dBm	PASS
	CH 6	8.37	/	30dBm	PASS
	CH 11	8.29	/	30dBm	PASS
IEEE 802.11N40	CH 3	8.05	/	30dBm	PASS
	CH 6	8.18	/	30dBm	PASS
	CH 9	8.33	/	30dBm	PASS

5. Power Spectral Density

5.1. Test equipment

Item	Equipment	Manufacturer	Model No.	Serial No.	Calibrated until	Calibrated Date
1	Spectrum analyzer	KEYSIGHT	N9010A	MY55150427	05/25/2019	05/26/2018
2	Attenuator	Mini-Circuits	BW-S10W2	101109	12/17/2018	12/18/2017
3	RF Cable	Micable	C10-01-01-1	100309	12/17/2018	12/18/2017

5.2. Block diagram of test setup

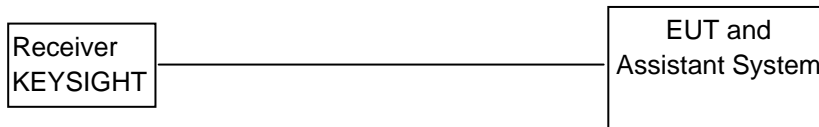

5.3. Limits

For digitally modulated systems, the power spectral density conducted from the intentional radiator to the antenna shall not be greater than 8dBm in any 3 kHz band during any time interval of continuous transmission.

5.4. TEST PROCEDURE

1. Check the calibration of the measuring instrument using either an internal calibrator or a known signal from an external generatorl.
2. Position the EUT was set without connection to measurement instrument. Turn on the EUT and connect its antenna terminal to measurement instrument via a low loss cable. Then set it to any one measured frequency within its operating range, and make sure the instrument is operated in its linear range
3. According to KDB 558074 , set the RBW = 3 kHz, VBW =10 kHz, Set the span to 1.5 times the DTS channel bandwidth.
4. Use the peak marker function to determine the maximum power level in any 3 kHz band segment within the fundamental EBW

5.5. Test Result

EUT Set Mode	CH	Result(dBm)	Total (dBm)	Limit (dBm)	Conclusion
IEEE 802.11B	CH 1	-24.81	/	8	PASS
	CH 6	-21.61	/	8	PASS
	CH 11	-17.89	/	8	PASS
IEEE 802.11G	CH 1	-26.02	/	8	PASS
	CH 6	-19.72	/	8	PASS
	CH 11	-17.30	/	8	PASS
IEEE 802.11N20	CH 1	-25.73	/	8	PASS
	CH 6	-19.72	/	8	PASS
	CH 11	-20.86	/	8	PASS
IEEE 802.11N40	CH 3	-23.10	/	8	PASS
	CH 6	-22.64	/	8	PASS
	CH 9	-22.45	/	8	PASS

5.6. Original test data

802.11 B Mode CH1

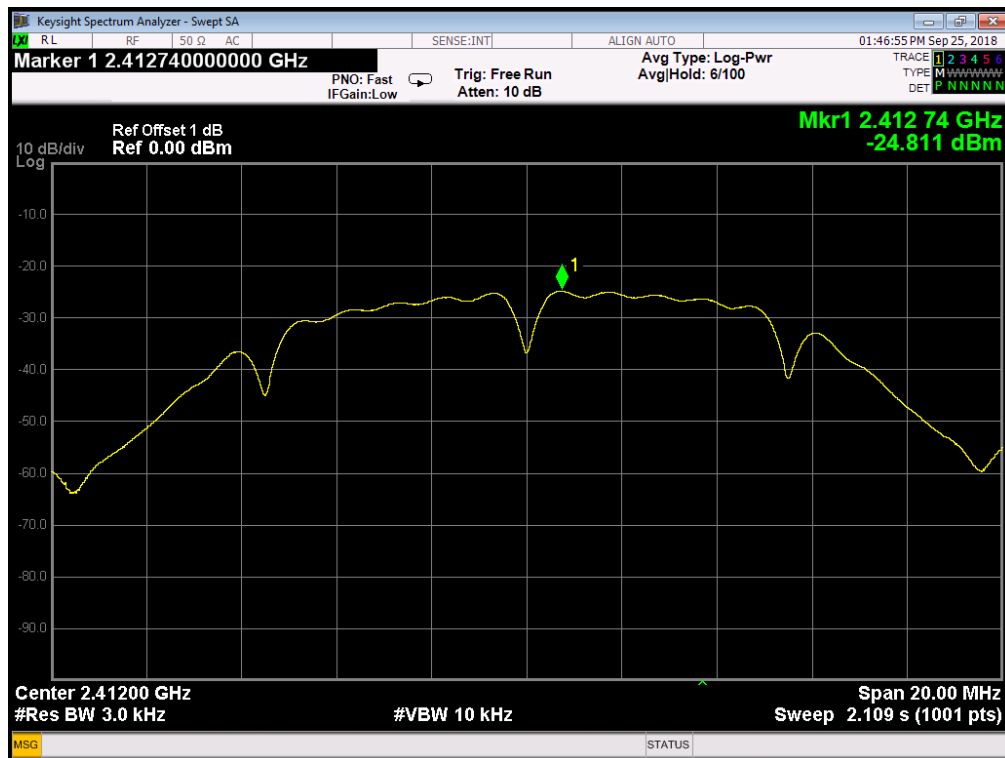

802.11 B Mode CH6



802.11 B Mode CH11



802.11 G Mode CH1

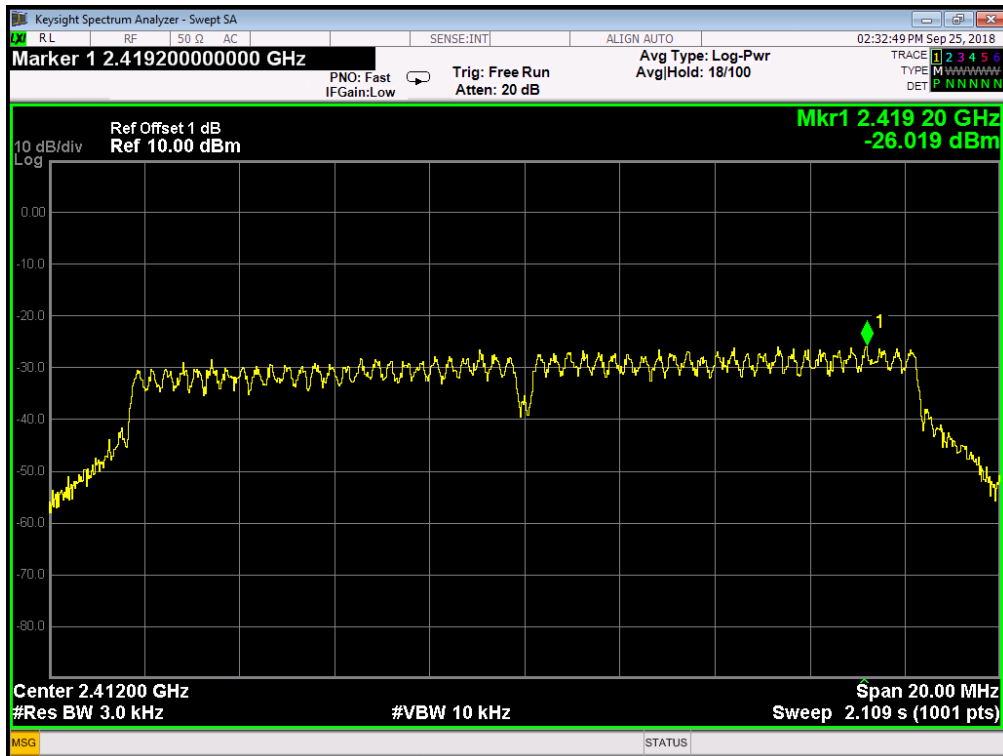

802.11 G Mode CH6

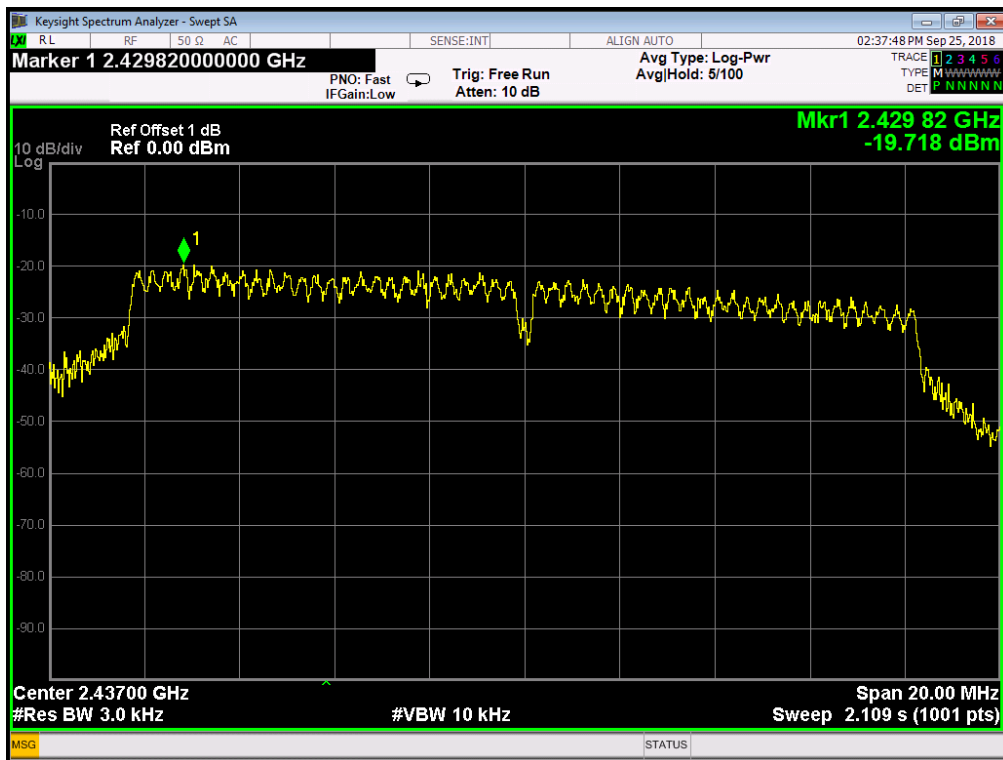

802.11 G Mode CH11

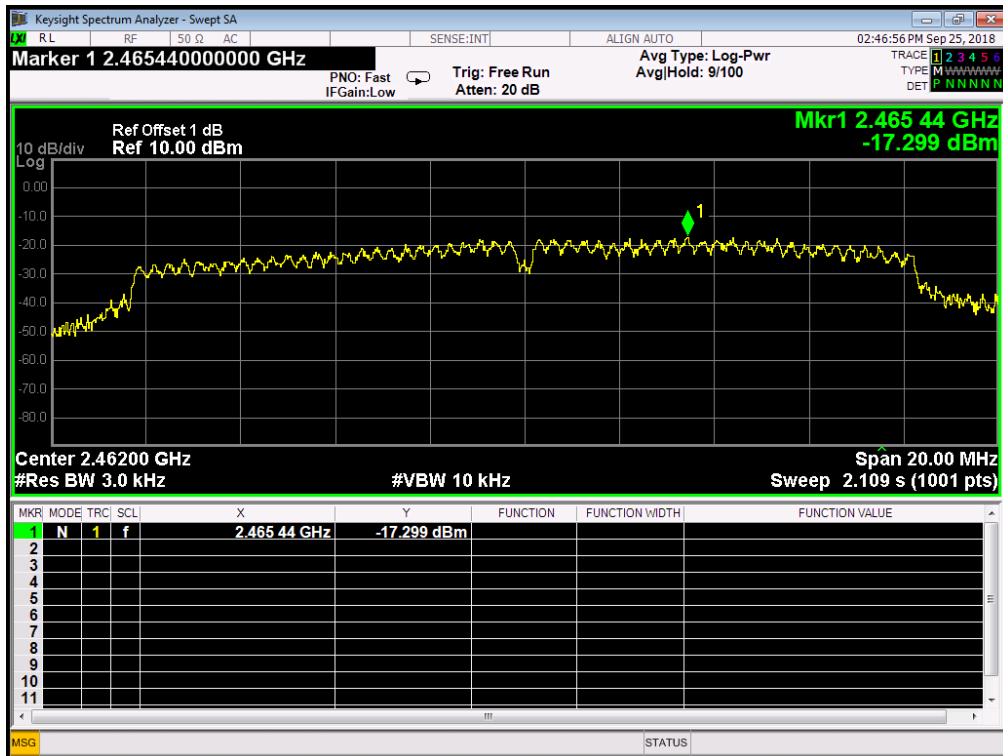

802.11 N20 Mode CH1

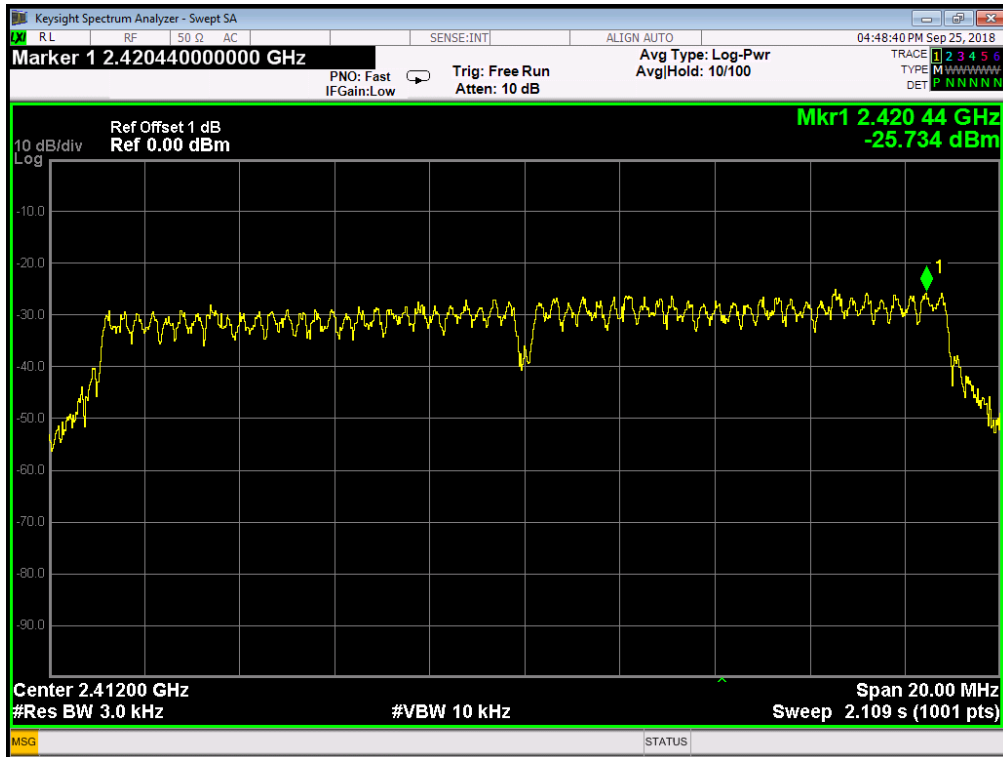

802.11 N20 Mode CH6

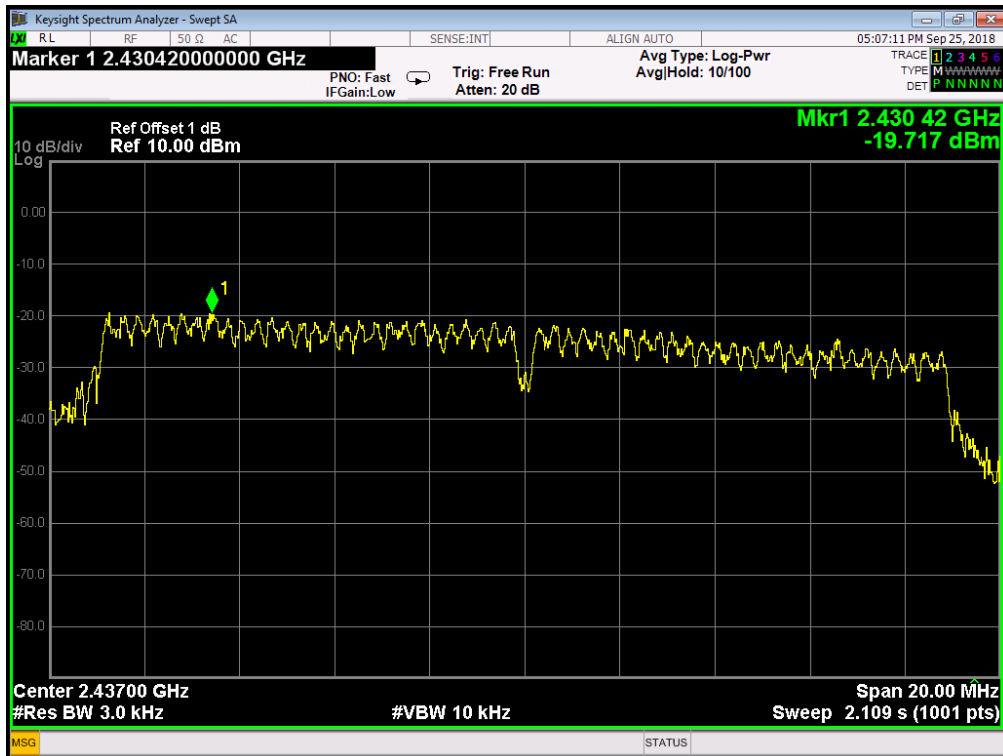

802.11 N20 Mode CH11

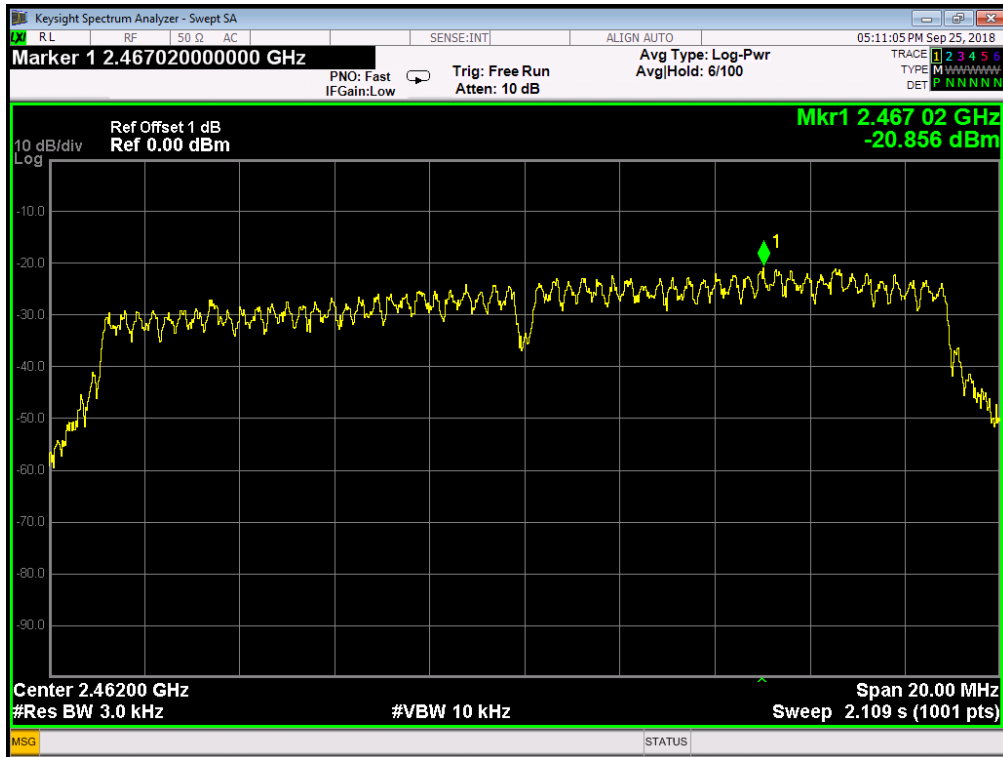

802.11 N40 Mode CH3

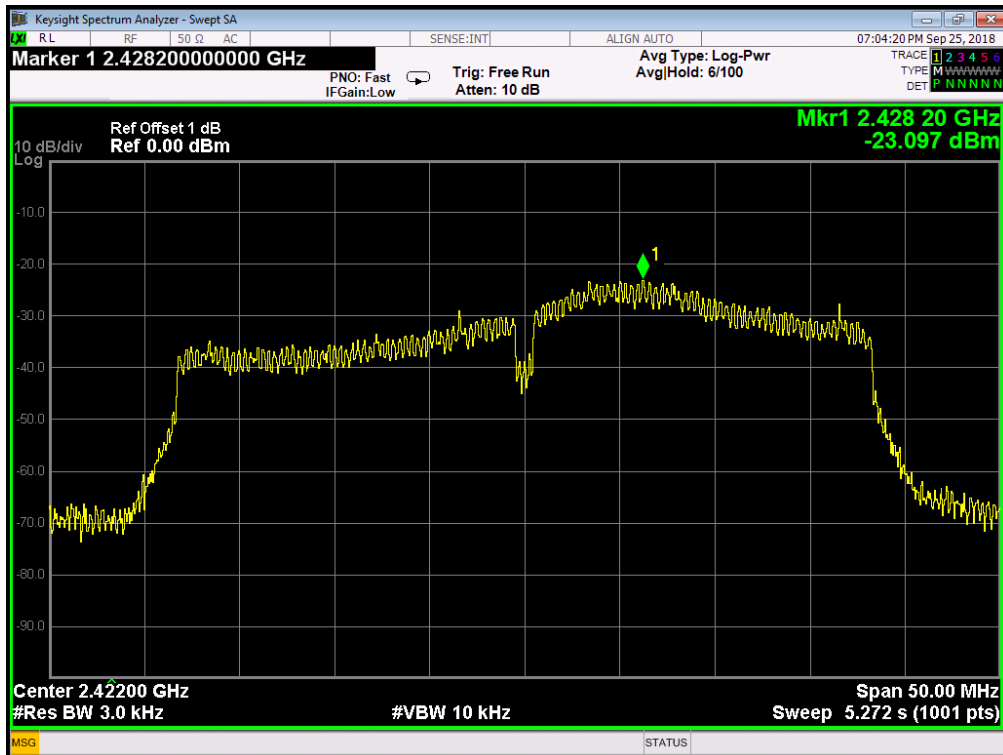

802.11 N40 Mode CH6

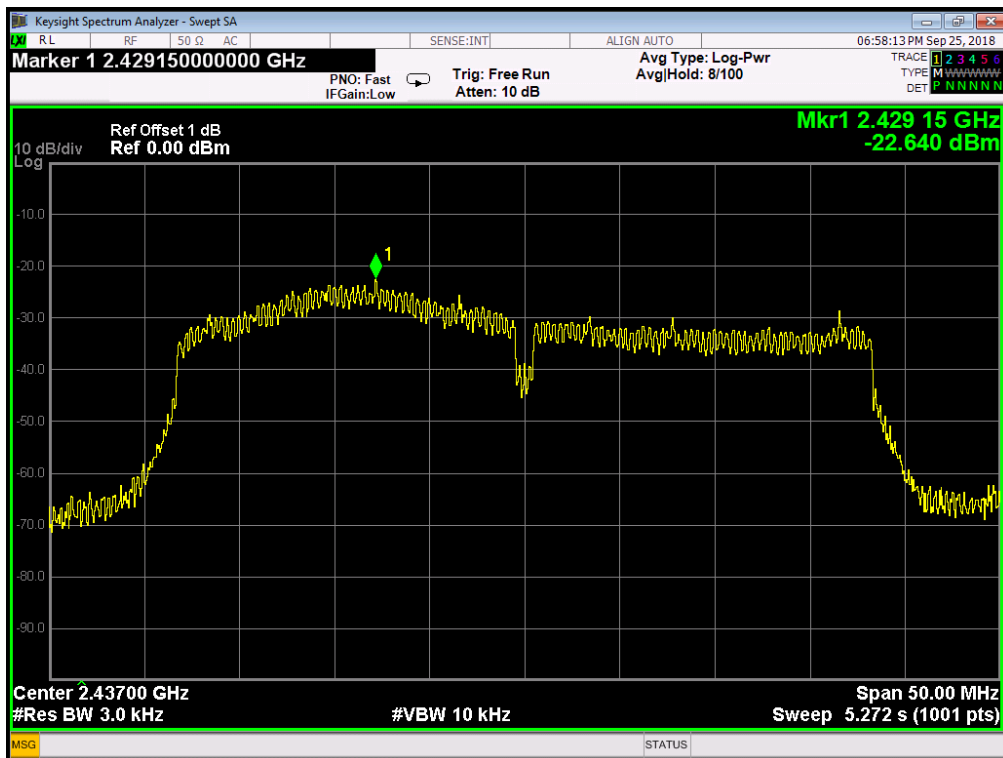

802.11 N40 Mode CH9

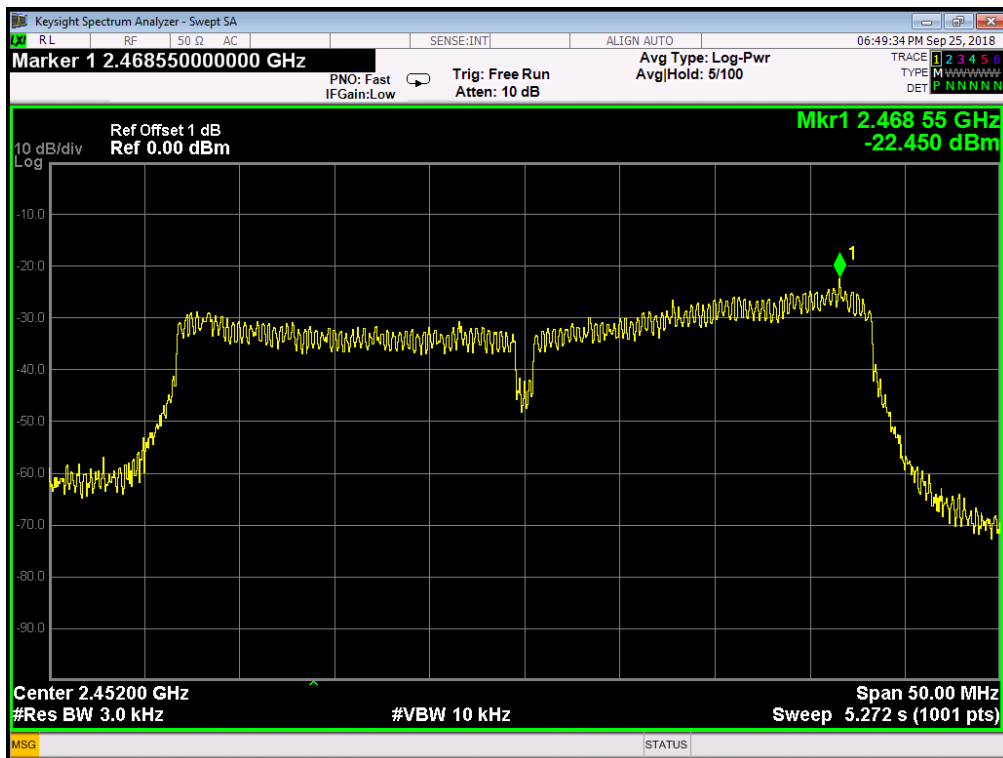

6. Spurious Emissions

6.1. Test equipment

Item	Equipment	Manufacturer	Model No.	Serial No.	Calibrated until	Calibrated Date
1	EMI Test Receiver	R&S	ESCI	101307	12/17/2018	12/18/2017
2	Spectrum analyzer	Agilent	E4407B	US40240708	07/03/2019	07/04/2018
3	Trilog Broadband Antenna	Schwarzbeck	VULB9168	VULB9168-192	03/04/2019	03/05/2018
4	Double Ridged Horn Antenna	SCHWARZBEC K	BBHA 9120D1065	100276	12/17/2018	12/18/2017
5	Double Ridged Horn Antenna	SCHWARZBEC K	BBHA 9120D1065	100546	12/17/2018	12/18/2017
6	Dipole antenna	Schwarzbeck	UHAP	1101	12/17/2018	12/18/2017
7	Dipole antenna	Schwarzbeck	VHAP	1118	12/17/2018	12/18/2017
8	Pre-Amplifier	CY	EMC011830	980136	12/17/2018	12/18/2017
9	Pre-amplifier	HP	8447F	3113A05680	12/17/2018	12/18/2017
10	RF Cable	R&S	R01	10403	12/17/2018	12/18/2017
11	RF Cable	R&S	R02	10512	12/17/2018	12/18/2017
12	RF Cable	R&S	R01	10454	12/17/2018	12/18/2017
13	RF Cable	R&S	R02	10343	12/17/2018	12/18/2017
14	6 dB Attenuator	EMEC	ATT6000-6-N N	N/A	11/21/2018	11/22/2017
15	Turn Table	UC	UC3000	N/A	N/A	N/A
16	Antenna Mast	UC	UC3000	N/A	N/A	N/A
17	Measurement Software	Farad	EZ-EMC (Ver.ATT-03 A)	N/A	N/A	N/A

6.2. Block diagram of test setup

In 3m Anechoic Chamber Test Setup Diagram for below 1GHz

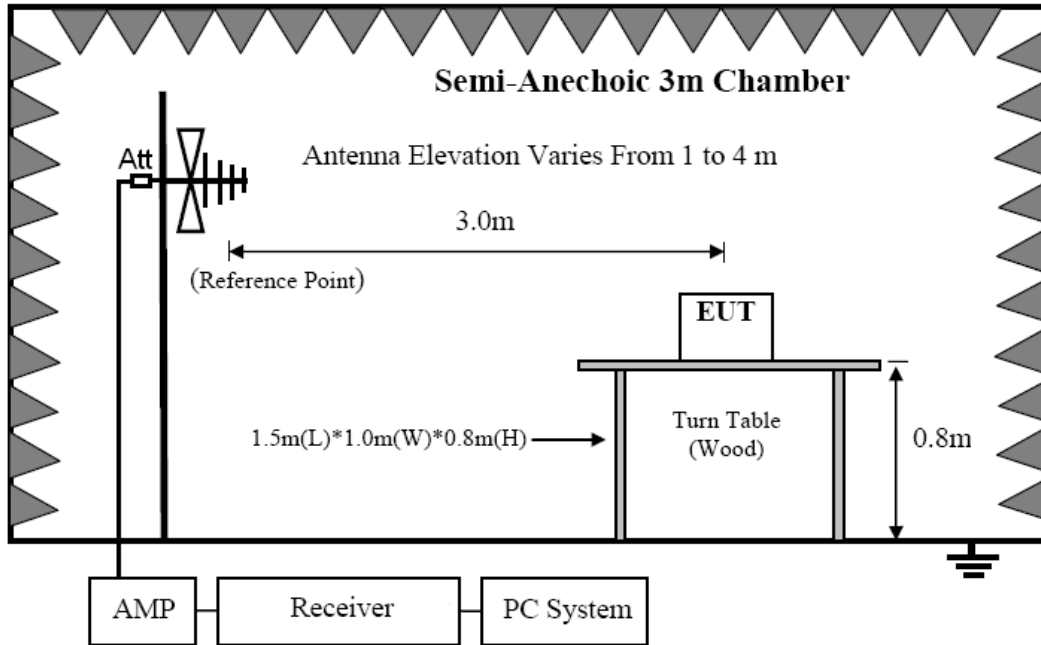

In 3m Anechoic Chamber Test Setup Diagram for frequency above 1GHz

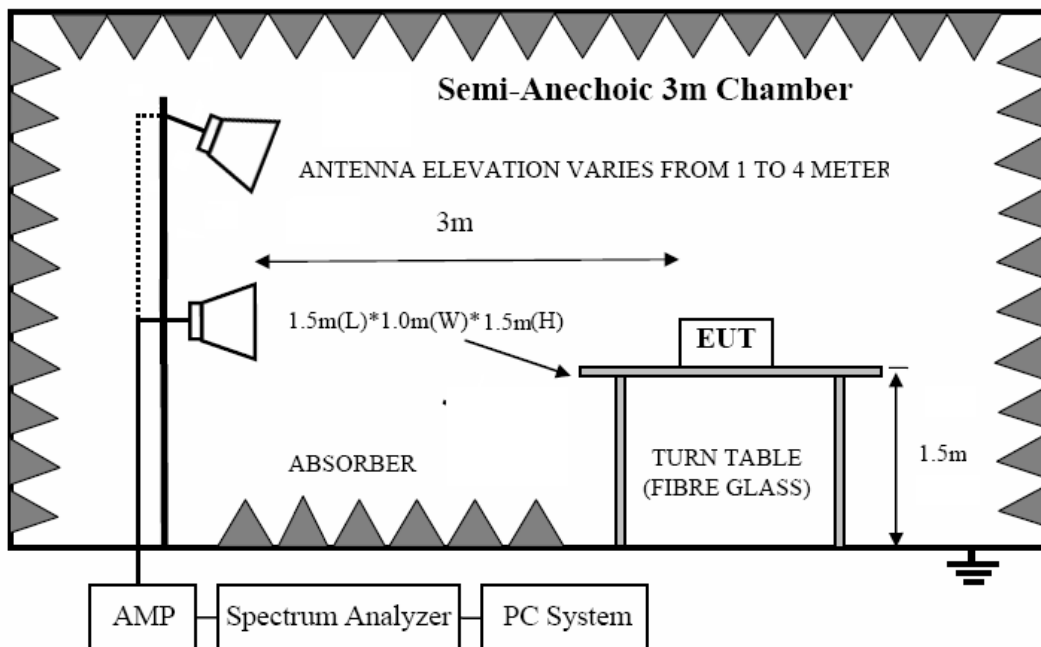

Note: For harmonic emissions test a appropriate high pass filter was inserted in the input port of AMP.

6.3. Limit

6.3.1 FCC 15.205 Restricted frequency band

MHz	MHz	MHz	GHz
0.090 - 0.110	16.42 - 16.423	399.9 - 410	4.5 - 5.15
¹ 0.495 - 0.505	16.69475 - 16.69525	608 - 614	5.35 - 5.46
2.1735 - 2.1905	16.80425 - 16.80475	960 - 1240	7.25 - 7.75
4.125 - 4.128	25.5 - 25.67	1300 - 1427	8.025 - 8.5
4.17725 - 4.17775	37.5 - 38.25	1435 - 1626.5	9.0 - 9.2
4.20725 - 4.20775	73 - 74.6	1645.5 - 1646.5	9.3 - 9.5
6.215 - 6.218	74.8 - 75.2	1660 - 1710	10.6 - 12.7
6.26775 - 6.26825	108 - 121.94	1718.8 - 1722.2	13.25 - 13.4
6.31175 - 6.31225	123 - 138	2200 - 2300	14.47 - 14.5
8.291 - 8.294	149.9 - 150.05	2310 - 2390	15.35 - 16.2
8.362 - 8.366	156.52475 - 156.52525	2483.5 - 2500	17.7 - 21.4
8.37625 - 8.38675	156.7 - 156.9	2690 - 2900	22.01 - 23.12
8.41425 - 8.41475	162.0125 - 167.17	3260 - 3267	23.6 - 24.0
12.29 - 12.293	167.72 - 173.2	3332 - 3339	31.2 - 31.8
12.51975 - 12.52025	240 - 285	3345.8 - 3358	36.43 - 36.5
12.57675 - 12.57725	322 - 335.4	3600 - 4400	(²)

6.3.2 FCC 15.209 Limit

FREQUENCY MHz	DISTANCE Meters	FIELD STRENGTHS LIMIT	
		$\mu\text{V}/\text{m}$	$\text{dB}(\mu\text{V})/\text{m}$
30 ~ 88	3	100	40.0
88 ~ 216	3	150	43.5
216 ~ 960	3	200	46.0
960 ~ 1000	3	500	54.0
Above 1000	3	74.0 $\text{dB}(\mu\text{V})/\text{m}$ (Peak) 54.0 $\text{dB}(\mu\text{V})/\text{m}$ (Average)	

6.3.3 Limit for this EUT

The radiated emission tests were performed in the 3 meters test site, using the setup accordance with the ANSI C63.10:2013. The specification used was the FCC 15.209, and FCC 15.247 limits.

6.4. TEST PROCEDURE

- (1) EUT was placed on a non-metallic table, 80 cm above the ground plane inside a semi-anechoic chamber.
- (2) Setup EUT and assistant system according clause 2.4 and 8.2
- (3) Test antenna was located 3m from the EUT on an adjustable mast. Below pre-scan procedure was first performed in order to find prominent radiated emissions.
 - (a) Change work frequency or channel of device if practicable.
 - (b) Change modulation type of device if practicable.
 - (c) Change power supply range from 85% to 115% of the rated supply voltage
 - (d) Rotated EUT though three orthogonal axes to determine the attitude of EUT arrangement produces highest emissions
- (4) Spectrum frequency from 9MHz to 25GHz (tenth harmonic of fundamental frequency) was investigated, and no any obvious emission were detected from 9KHz to 30MHz and 18GHz to 25GHz, so below final test was performed with frequency range from 30MHz to 18GHz.
- (5) For final emissions measurements at each frequency of interest, the EUT were rotated and the antenna height was varied between 1m and 4m in order to maximize the emission. Measurements in both horizontal and vertical polarities were made and the data was recorded. In order to find the maximum emission, the relative positions of equipments and all of the interface cables were changed according to ANSI C63.10 2013 on Radiated Emission test.
- (6) For emissions from 30MHz to 1GHz, Quasi-Peak values were measured with EMI Receiver and the bandwidth of Receiver is 120 KHz.
- (7) For emissions above 1GHz, both Peak and Average level were measured with Spectrum Analyzer, and the RBW is set at 1MHz, VBW is set at 3MHz for Peak measure, Detector is at PK; RBW is set at 1MHz, VBW is set at 3MHz for Average measure, Detector is at RMS.

6.5. TEST RESULT

Below 30M

EUT:	8"Android Tablet	Model No.:	SE-ET8
Temperature:	24°C	Relative Humidity:	55%
Distance:	3m	Test Power:	120V/60Hz
Polarization:	--	Test Result:	Pass
Test Mode:	Keep TX Mode	Test By:	smile

Freq. (MHz)	Reading (dBuV/m)	Limit (dBuV/m)	Margin (dB)	State P/F
--	--	--	--	P
--	--	--	--	P

Note:

The amplitude of spurious emissions which are attenuated by more than 20dB below the permissible value has no need to be reported.

Distance extrapolation factor = $20 \log(\text{specific distance}/\text{test distance})(\text{dB})$;

Limit line = specific limits(dBuv) + distance extrapolation factor

Between 30M – 1000 MHz

EUT:	8"Android Tablet	Model No.:	SE-ET8
Temperature:	24	Relative Humidity:	55%
Distance:	3m	Test Power:	120V/60Hz
Polarization:	Vertical	Test Result:	Pass
Standard:	(RE)FCC PART 15 class B 3m	Test By:	smile
Test Mode:	Keep TX Mode		

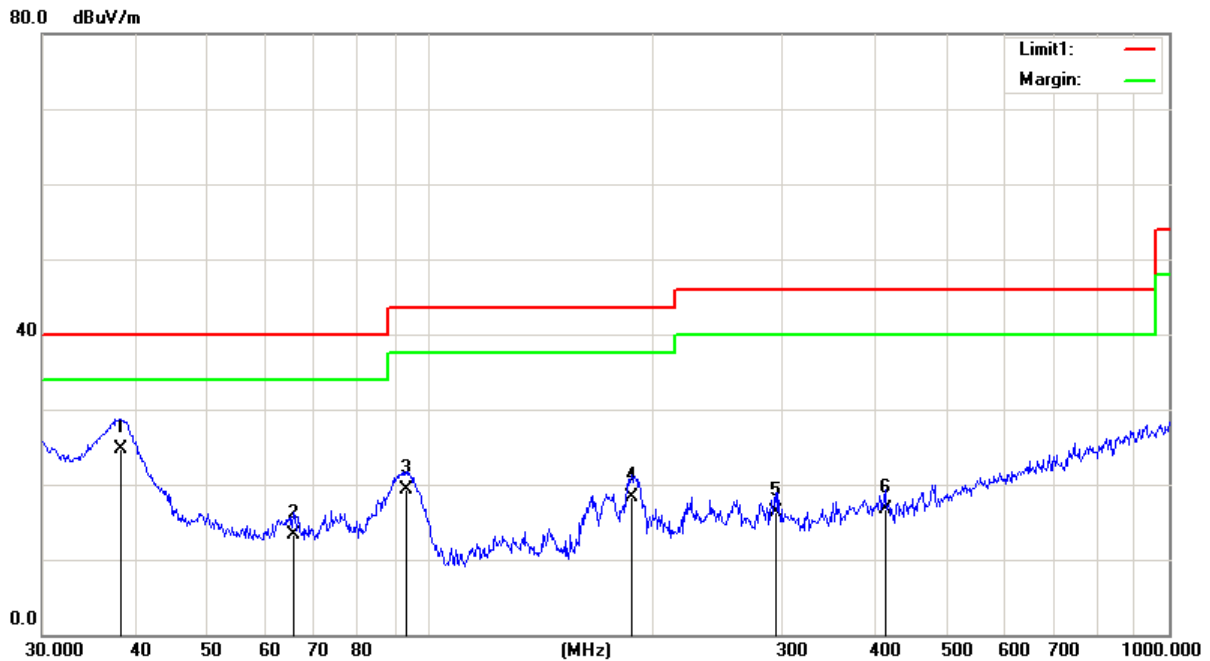

No.	Frequency (MHz)	Reading (dBuV/m)	Correct Factor(dB/m)	Result (dBuV/m)	Limit (dBuV/m)	Margin (dB)	Remark
1	38.3462	38.18	-13.49	24.69	40.00	-15.31	QP
2	65.5727	26.50	-13.22	13.28	40.00	-26.72	QP
3	93.1132	34.93	-15.62	19.31	43.50	-24.19	QP
4	187.7530	30.21	-11.94	18.27	43.50	-25.23	QP
5	294.1137	25.03	-8.75	16.28	46.00	-29.72	QP
6	413.2706	23.99	-7.22	16.77	46.00	-29.23	QP

The test result is calculated as the following:

- (1) Result = Reading + Correct Factor
- (2) Correct Factor = Antenna Factor + Cable Loss – Amplifier Gain + Attenuator
- (3) Margin = Result - Limit

EUT:	8"Android Tablet	Model No.:	SE-ET8
Temperature:	24	Relative Humidity:	55%
Distance:	3m	Test Power:	120V/60Hz
Polarization:	Horizontal	Test Result:	Pass
Standard:	(RE)FCC PART 15 class B 3m	Test By:	smile
Test Mode:	Keep TX Mode		



No.	Frequency (MHz)	Reading (dBuV/m)	Correct Factor(dB/m)	Result (dBuV/m)	Limit (dBuV/m)	Margin (dB)	Remark
1	95.0930	30.15	-17.50	12.65	43.50	-30.85	QP
2	172.5988	28.90	-10.56	18.34	43.50	-25.16	QP
3	191.7450	28.52	-10.19	18.33	43.50	-25.17	QP
4	239.1473	26.07	-6.89	19.18	46.00	-26.82	QP
5	290.0172	31.45	-7.77	23.68	46.00	-22.32	QP
6	912.8620	22.26	1.92	24.18	46.00	-21.82	QP

The test result is calculated as the following:

- (1) Result = Reading + Correct Factor
- (2) Correct Factor = Antenna Factor + Cable Loss – Amplifier Gain + Attenuator
- (3) Margin = Result - Limit

Between 1000M – 25000 MHz

Test Site	: 3m Chamber		
EUT	: 8"Android Tablet	Tested By	: Smile
Power Supply	: 3.8 Vdc	Model Number	: SE-ET8
Condition	: Temp:24.5'C,Humi:55%, Press:100.1kPa	Test Mode	: Tx mode
Memo	: 802.11b (Worst Case of all modes)	Antenna/Distance	:

EUT:	8"Android Tablet	Model No.:	SE-ET8
Temperature:	24	Relative Humidity:	55%
Distance:	3m	Test Power:	DC 3.8V
Polarization:	Horizontal	Test Result:	Pass
Test Time:	2018-9-22	Test By:	Smile
Standard:	FCC PART 15 C 1-26.5G PEAK		
Test Mode:	TX		
Note:	B 2412		

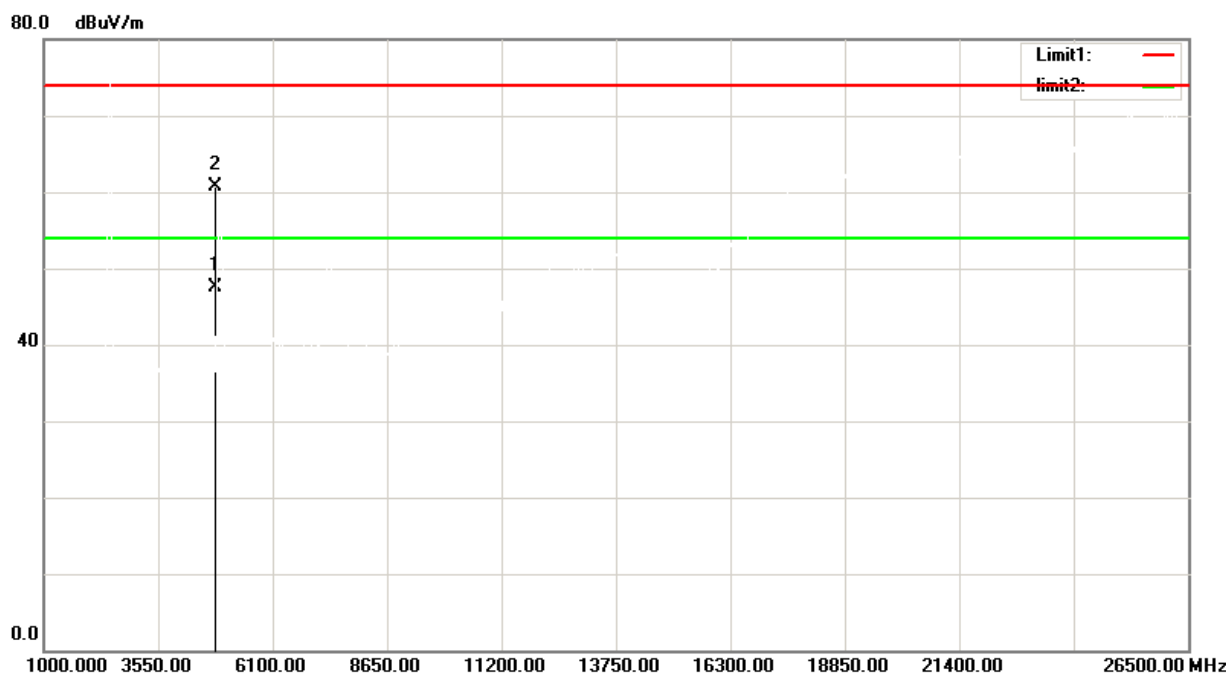

No.	Frequency (MHz)	Reading (dBuV/m)	Correct Factor(dB/m)	Result (dBuV/m)	Limit (dBuV/m)	Margin (dB)	Remark
1	4824.000	58.25	-10.70	47.55	54.00	-6.45	AVG
2	4824.000	71.35	-10.70	60.65	74.00	-13.35	peak

The test result is calculated as the following:

- (1) Result = Reading + Correct Factor
- (2) Correct Factor = Antenna Factor + Cable Loss – Amplifier Gain + Attenuator
- (3) Margin = Result - Limit

EUT:	8" Android Tablet	Model No.:	SE-ET8
Temperature:	24	Relative Humidity:	55%
Distance:	3m	Test Power:	DC 3.8V
Polarization:	Vertical	Test Result:	Pass
Test Time:	2018-9-22	Test By:	Smile
Standard:	FCC PART 15 C 1-26.5G PEAK		
Test Mode:	TX		
Note:	B 2412		

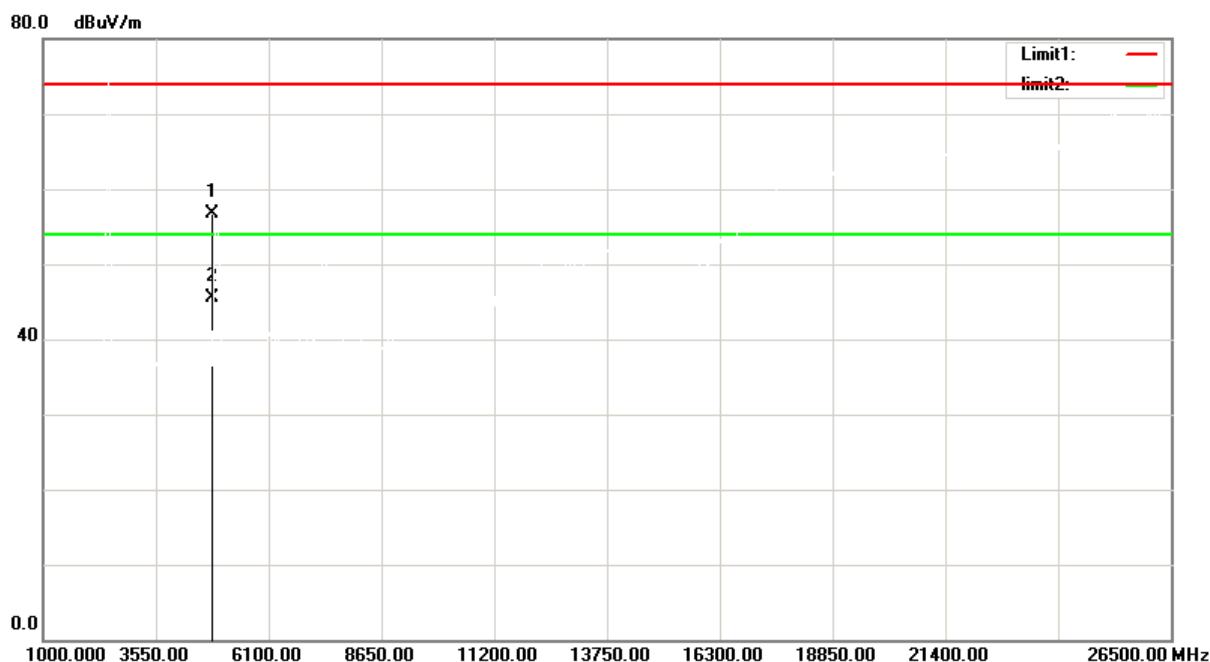

No.	Frequency (MHz)	Reading (dBuV/m)	Correct Factor (dB/m)	Result (dBuV/m)	Limit (dBuV/m)	Margin (dB)	Remark
1	4824.000	67.34	-10.70	56.64	74.00	-17.36	peak
2	4824.000	56.22	-10.70	45.52	54.00	-8.48	AVG

The test result is calculated as the following:

- (1) Result = Reading + Correct Factor
- (2) Correct Factor = Antenna Factor + Cable Loss – Amplifier Gain + Attenuator
- (3) Margin = Result - Limit

EUT:	8" Android Tablet	Model No.:	SE-ET8
Temperature:	24	Relative Humidity:	55%
Distance:	3m	Test Power:	DC 3.8V
Polarization:	Vertical	Test Result:	Pass
Test Time:	2018-9-22	Test By:	Smile
Standard:	FCC PART 15 C 1-26.5G PEAK		
Test Mode:	TX		
Note:	B 2437		

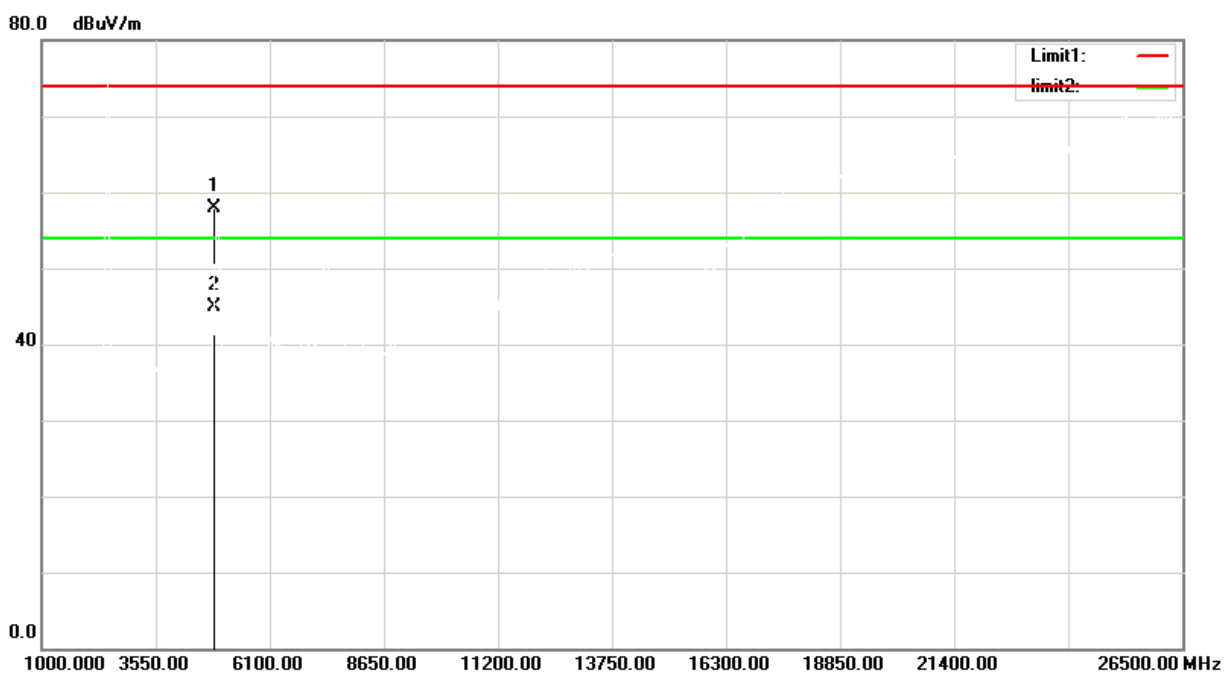

No.	Frequency (MHz)	Reading (dBuV/m)	Correct Factor(dB/m)	Result (dBuV/m)	Limit (dBuV/m)	Margin (dB)	Remark
1	4874.000	68.35	-10.46	57.89	74.00	-16.11	peak
2	4874.000	55.43	-10.46	44.97	54.00	-9.03	AVG

The test result is calculated as the following:

- (1) Result = Reading + Correct Factor
- (2) Correct Factor = Antenna Factor + Cable Loss – Amplifier Gain + Attenuator
- (3) Margin = Result - Limit

EUT:	8" Android Tablet	Model No.:	SE-ET8
Temperature:	24	Relative Humidity:	55%
Distance:	3m	Test Power:	DC 3.8V
Polarization:	Horizontal	Test Result:	Pass
Test Time:	2018-9-22	Test By:	Smile
Standard:	FCC PART 15 C 1-26.5G PEAK		
Test Mode:	TX		
Note:	B 2437		

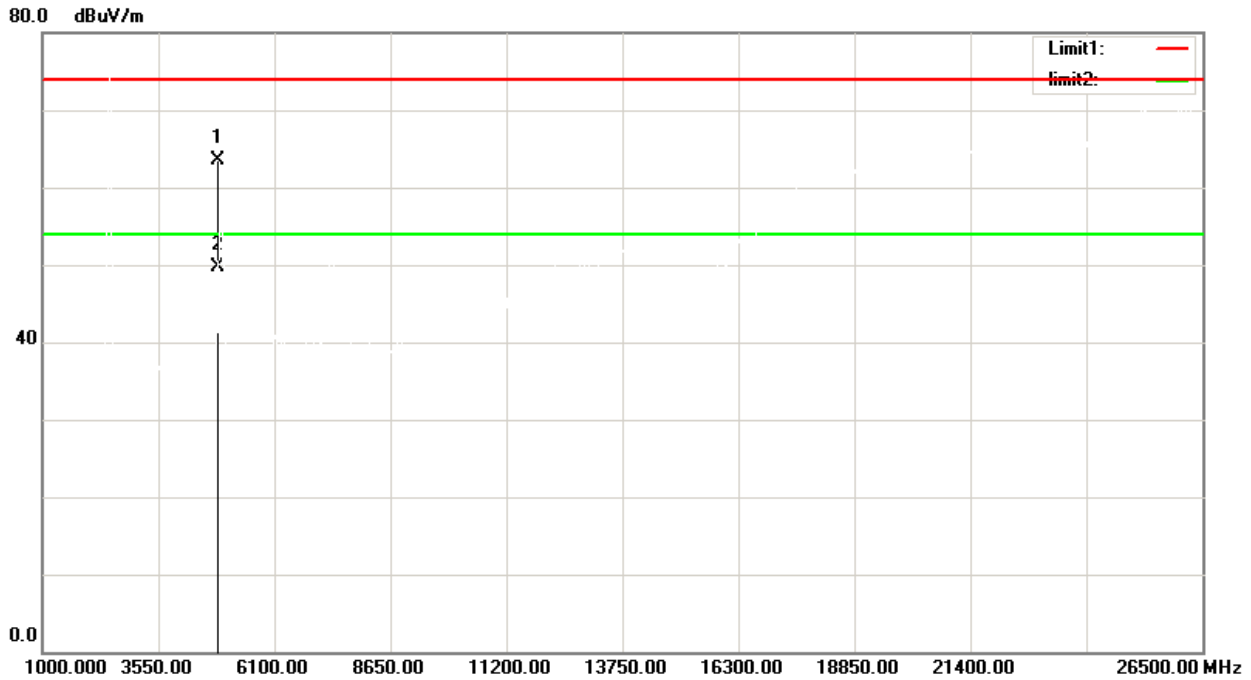

No.	Frequency (MHz)	Reading (dBuV/m)	Correct Factor (dB/m)	Result (dBuV/m)	Limit (dBuV/m)	Margin (dB)	Remark
1	4874.000	73.87	-10.46	63.41	74.00	-10.59	peak
2	4874.000	60.19	-10.46	49.73	54.00	-4.27	AVG

The test result is calculated as the following:

- (1) Result = Reading + Correct Factor
- (2) Correct Factor = Antenna Factor + Cable Loss – Amplifier Gain + Attenuator
- (3) Margin = Result - Limit

EUT:	8" Android Tablet	Model No.:	SE-ET8
Temperature:	24	Relative Humidity:	55%
Distance:	3m	Test Power:	DC 3.8V
Polarization:	Horizontal	Test Result:	Pass
Test Time:	2018-9-22	Test By:	Smile
Standard:	FCC PART 15 C 1-26.5G PEAK		
Test Mode:	TX		
Note:	B 2462		

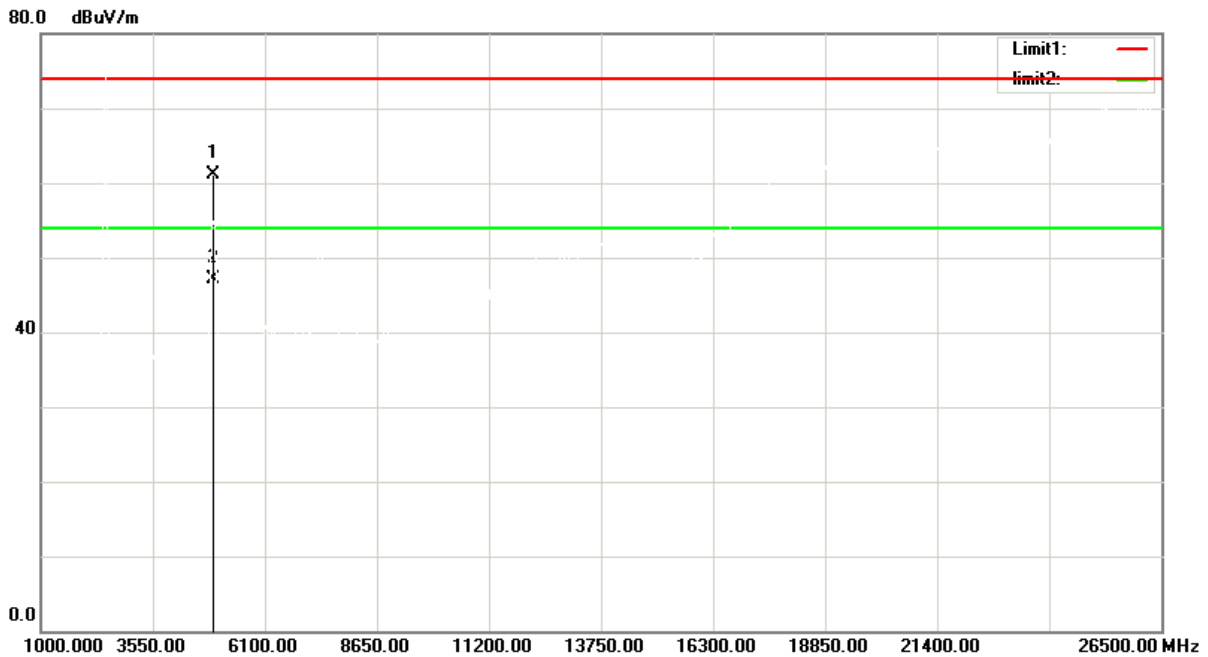

No.	Frequency (MHz)	Reading (dBuV/m)	Correct Factor (dB/m)	Result (dBuV/m)	Limit (dBuV/m)	Margin (dB)	Remark
1	4924.000	71.35	-10.24	61.11	74.00	-12.89	peak
2	4924.000	57.44	-10.24	47.20	54.00	-6.80	AVG

The test result is calculated as the following:

- (1) Result = Reading + Correct Factor
- (2) Correct Factor = Antenna Factor + Cable Loss – Amplifier Gain + Attenuator
- (3) Margin = Result - Limit

EUT:	8" Android Tablet	Model No.:	SE-ET8
Temperature:	24	Relative Humidity:	55%
Distance:	3m	Test Power:	DC 3.8V
Polarization:	Vertical	Test Result:	Pass
Test Time:	2018-9-22	Test By:	Smile
Standard:	FCC PART 15 C 1-26.5G PEAK		
Test Mode:	TX		
Note:	B 2462		

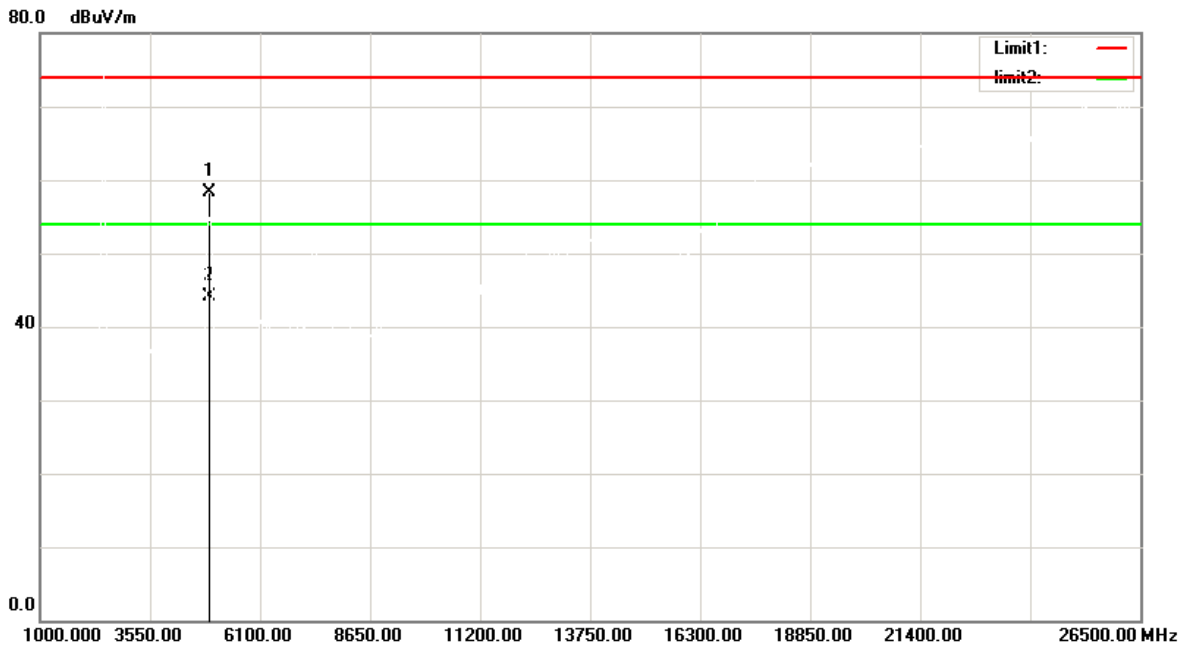

No.	Frequency (MHz)	Reading (dBuV/m)	Correct Factor(dB/m)	Result (dBuV/m)	Limit (dBuV/m)	Margin (dB)	Remark
1	4924.000	68.54	-10.24	58.30	74.00	-15.70	peak
2	4924.000	54.38	-10.24	44.14	54.00	-9.86	AVG

The test result is calculated as the following:

- (1) Result = Reading + Correct Factor
- (2) Correct Factor = Antenna Factor + Cable Loss – Amplifier Gain + Attenuator
- (3) Margin = Result - Limit

Radiated Band Edge:

EUT:	8" Android Tablet	Model No.:	SE-ET8
Temperature:	24	Relative Humidity:	55%
Distance:	3m	Test Power:	DC 3.8V
Polarization:	Vertical	Test Result:	Pass
Test Time:	2018-9-22	Test By:	Smile
Standard:	FCC PART 15 C 1-26.5G PEAK		
Test Mode:	TX		
Note:	B 2412		

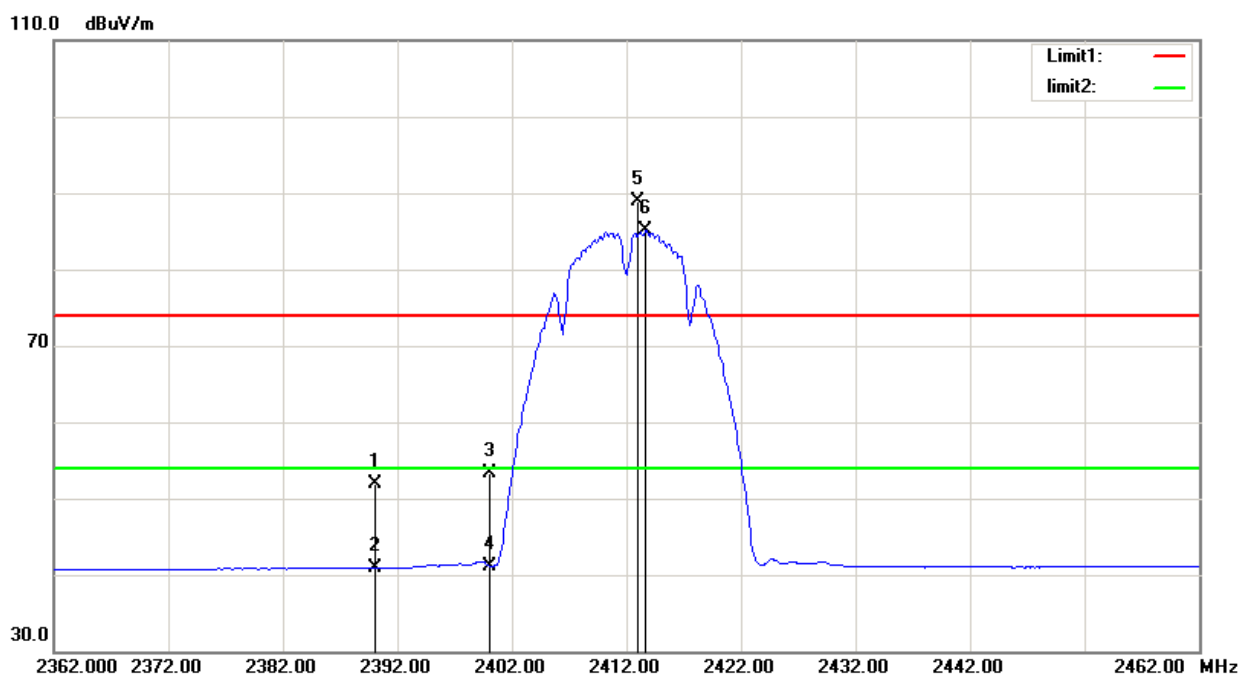

No.	Frequency (MHz)	Reading (dBuV/m)	Correct Factor (dB/m)	Result (dBuV/m)	Limit (dBuV/m)	Margin (dB)	Remark
1	2390.000	21.01	30.85	51.86	74.00	-22.14	peak
2	2390.000	10.06	30.85	40.91	54.00	-13.09	AVG
3	2400.000	22.52	30.87	53.39	74.00	-20.61	peak
4	2400.000	10.30	30.87	41.17	54.00	-12.83	AVG
5	2413.000	58.02	30.90	88.92	/	/	peak
6	2413.700	54.22	30.90	85.12	/	/	AVG

The test result is calculated as the following:

- (1) Result = Reading + Correct Factor
- (2) Correct Factor = Antenna Factor + Cable Loss – Amplifier Gain + Attenuator
- (3) Margin = Result - Limit

EUT:	8" Android Tablet	Model No.:	SE-ET8
Temperature:	24	Relative Humidity:	55%
Distance:	3m	Test Power:	DC 3.8V
Polarization:	Horizontal	Test Result:	Pass
Test Time:	2018-9-22	Test By:	Smile
Standard:	FCC PART 15 C 1-26.5G PEAK		
Test Mode:	TX		
Note:	B 2412		

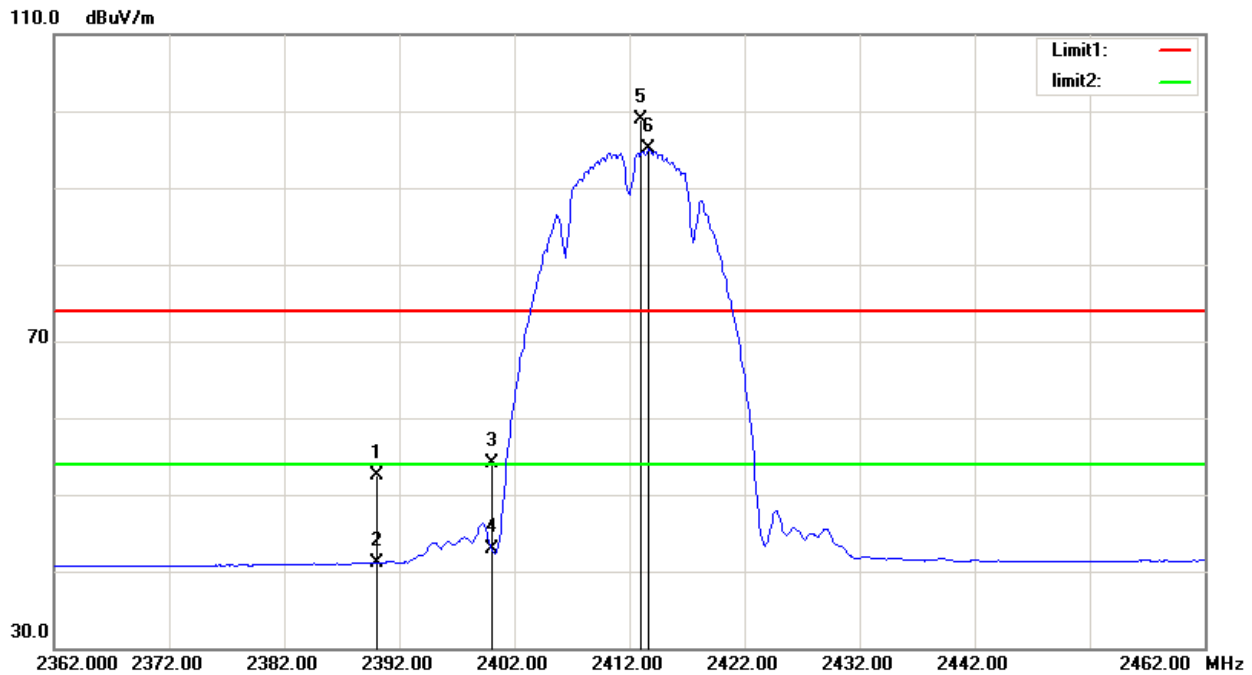

No.	Frequency (MHz)	Reading (dBuV/m)	Correct Factor(dB/m)	Result (dBuV/m)	Limit (dBuV/m)	Margin (dB)	Remark
1	2390.000	21.63	30.85	52.48	74.00	-21.52	peak
2	2390.000	10.28	30.85	41.13	54.00	-12.87	AVG
3	2400.000	23.32	30.87	54.19	74.00	-19.81	peak
4	2400.000	12.07	30.87	42.94	54.00	-11.06	AVG
5	2413.000	67.91	30.90	98.81	/	/	peak
6	2413.700	64.11	30.90	95.01	/	/	AVG

The test result is calculated as the following:

- (1) Result = Reading + Correct Factor
- (2) Correct Factor = Antenna Factor + Cable Loss – Amplifier Gain + Attenuator
- (3) Margin = Result - Limit

EUT:	8" Android Tablet	Model No.:	SE-ET8
Temperature:	24	Relative Humidity:	55%
Distance:	3m	Test Power:	DC 3.8V
Polarization:	Horizontal	Test Result:	Pass
Test Time:	2018-9-22	Test By:	Smile
Standard:	FCC PART 15 C 1-26.5G PEAK		
Test Mode:	TX		
Note:	B 2462		

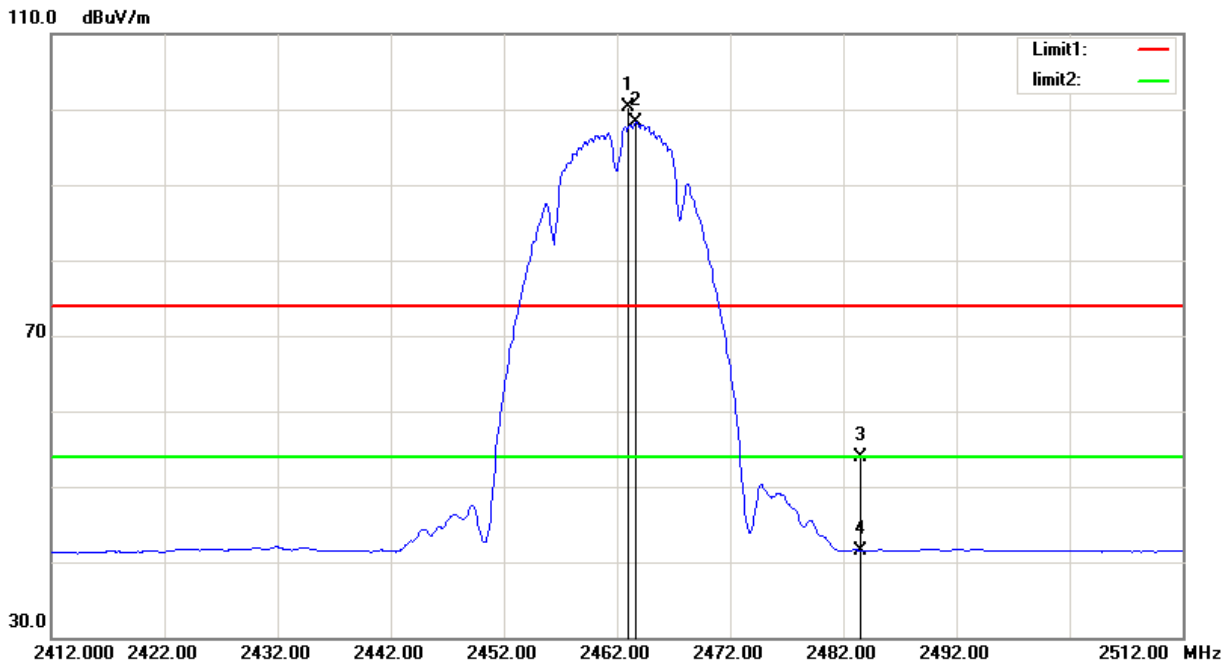

No.	Frequency (MHz)	Reading (dBuV/m)	Correct Factor (dB/m)	Result (dBuV/m)	Limit (dBuV/m)	Margin (dB)	Remark
1	2463.000	69.19	31.02	100.21	/	/	peak
2	2463.700	67.31	31.02	98.33	/	/	AVG
3	2483.500	22.89	31.07	53.96	74.00	-20.04	peak
4	2483.500	10.46	31.07	41.53	54.00	-12.47	AVG

The test result is calculated as the following:

- (1) Result = Reading + Correct Factor
- (2) Correct Factor = Antenna Factor + Cable Loss – Amplifier Gain + Attenuator
- (3) Margin = Result - Limit

EUT:	8" Android Tablet	Model No.:	SE-ET8
Temperature:	24	Relative Humidity:	55%
Distance:	3m	Test Power:	DC 3.8V
Polarization:	Vertical	Test Result:	Pass
Test Time:	2018-9-22	Test By:	Smile
Standard:	FCC PART 15 C 1-26.5G PEAK		
Test Mode:	TX		
Note:	B 2462		

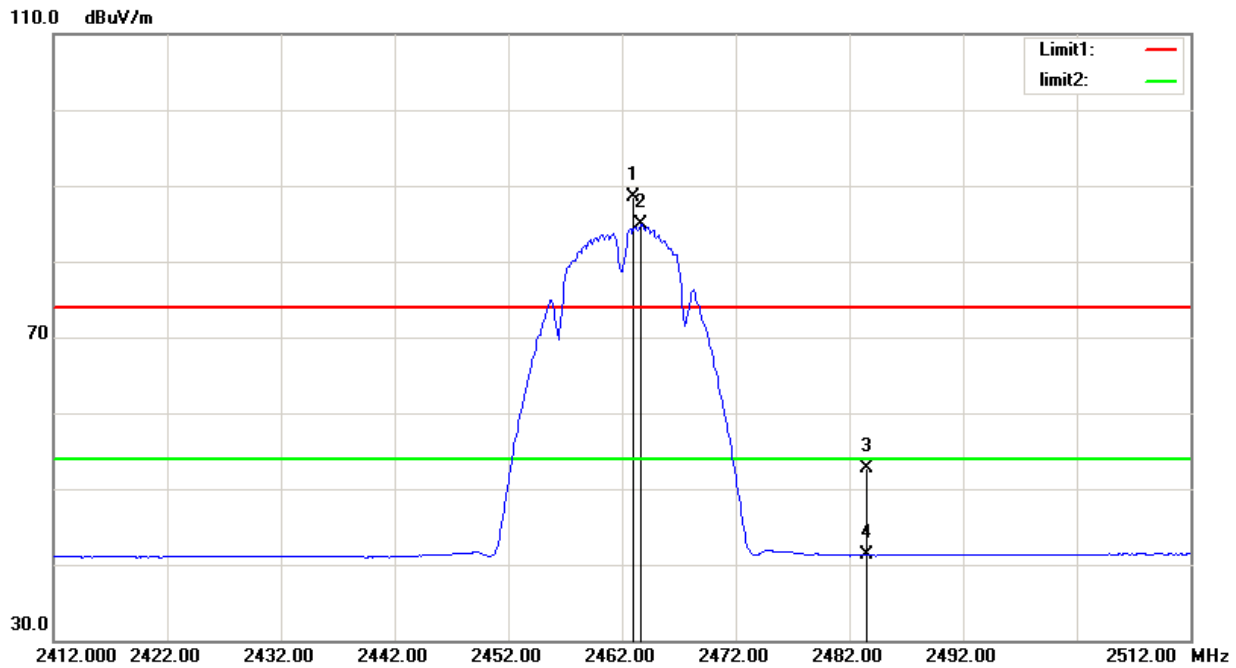

No.	Frequency (MHz)	Reading (dBuV/m)	Correct Factor (dB/m)	Result (dBuV/m)	Limit (dBuV/m)	Margin (dB)	Remark
1	2463.000	57.53	31.02	88.55	/	/	peak
2	2463.700	53.83	31.02	84.85	/	/	AVG
3	2483.500	21.72	31.07	52.79	74.00	-21.21	peak
4	2483.500	10.15	31.07	41.22	54.00	-12.78	AVG

The test result is calculated as the following:

- (1) Result = Reading + Correct Factor
- (2) Correct Factor = Antenna Factor + Cable Loss – Amplifier Gain + Attenuator
- (3) Margin = Result - Limit

EUT:	8" Android Tablet	Model No.:	SE-ET8
Temperature:	24	Relative Humidity:	55%
Distance:	3m	Test Power:	DC 3.8V
Polarization:	Vertical	Test Result:	Pass
Test Time:	2018-9-22	Test By:	Smile
Standard:	FCC PART 15 C 1-26.5G PEAK		
Test Mode:	TX		
Note:	G 2412		

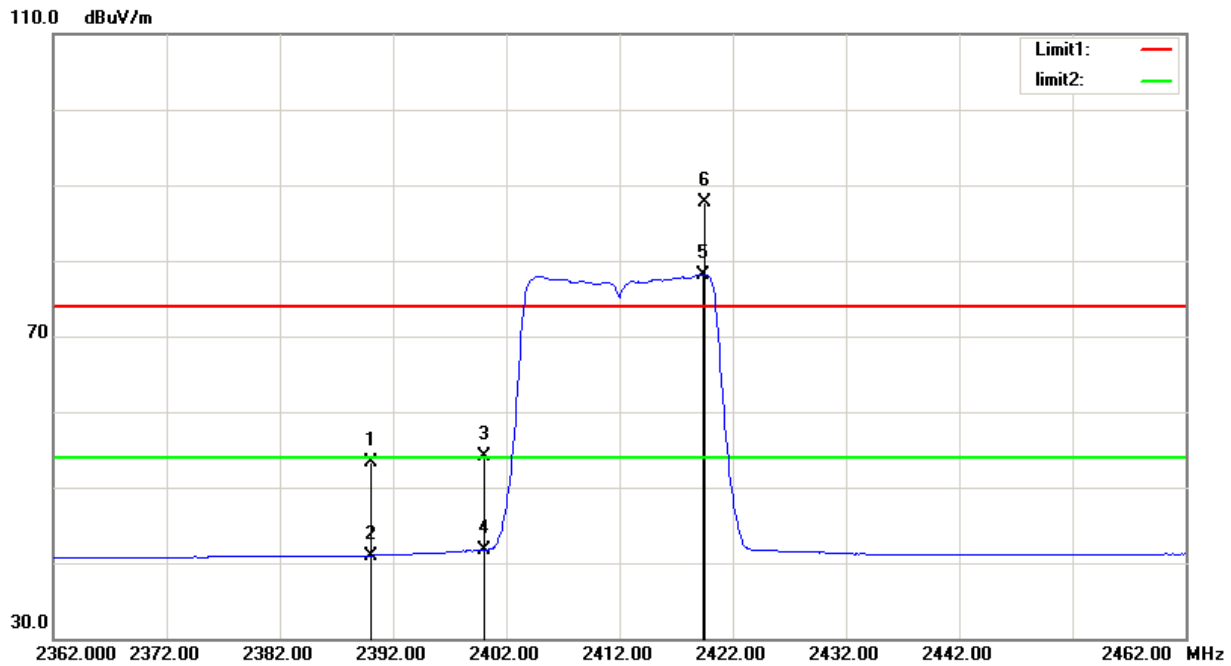

No.	Frequency (MHz)	Reading (dBuV/m)	Correct Factor (dB/m)	Result (dBuV/m)	Limit (dBuV/m)	Margin (dB)	Remark
1	2390.000	22.52	30.85	53.37	74.00	-20.63	peak
2	2390.000	10.14	30.85	40.99	54.00	-13.01	AVG
3	2400.000	23.15	30.87	54.02	74.00	-19.98	peak
4	2400.000	10.88	30.87	41.75	54.00	-12.25	AVG
5	2419.400	47.24	30.92	78.16	/	/	AVG
6	2419.500	56.76	30.92	87.68	/	/	peak

The test result is calculated as the following:

- (1) Result = Reading + Correct Factor
- (2) Correct Factor = Antenna Factor + Cable Loss – Amplifier Gain + Attenuator
- (3) Margin = Result - Limit

EUT:	8" Android Tablet	Model No.:	SE-ET8
Temperature:	24	Relative Humidity:	55%
Distance:	3m	Test Power:	DC 3.8V
Polarization:	Horizontal	Test Result:	Pass
Test Time:	2018-9-22	Test By:	Smile
Standard:	FCC PART 15 C 1-26.5G PEAK		
Test Mode:	TX		
Note:	G 2412		

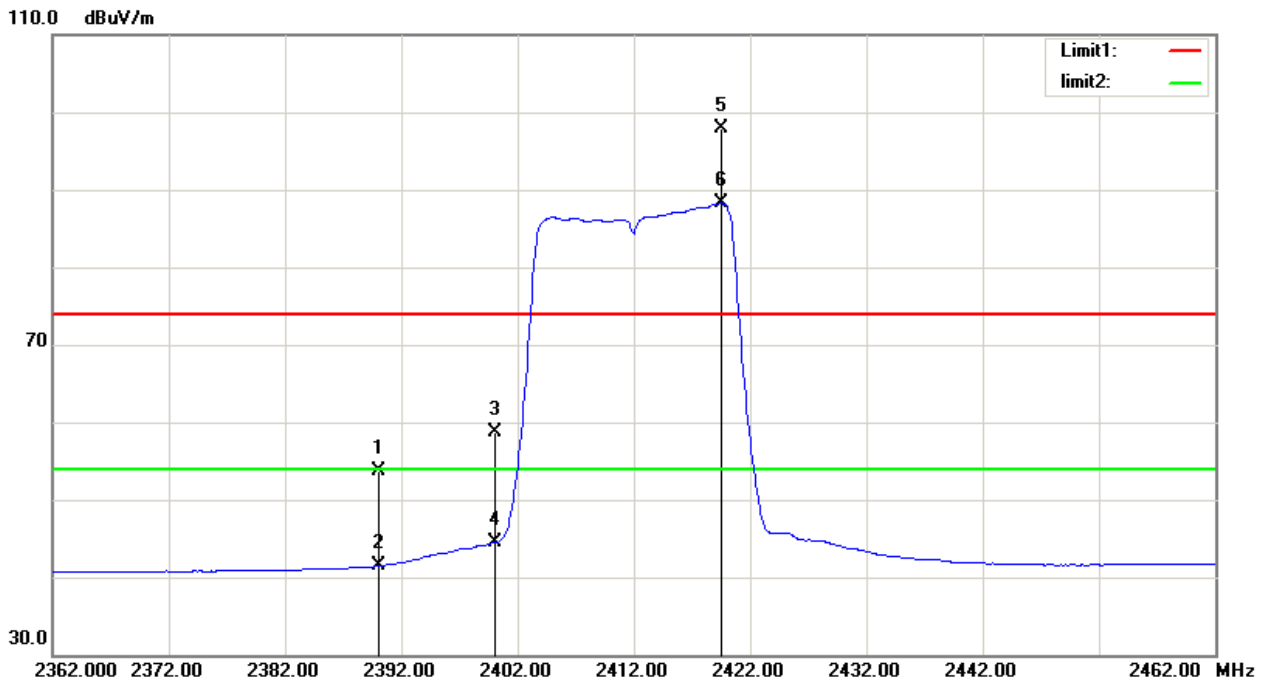

No.	Frequency (MHz)	Reading (dBuV/m)	Correct Factor (dB/m)	Result (dBuV/m)	Limit (dBuV/m)	Margin (dB)	Remark
1	2390.000	22.88	30.85	53.73	74.00	-20.27	peak
2	2390.000	10.62	30.85	41.47	54.00	-12.53	AVG
3	2400.000	27.91	30.87	58.78	74.00	-15.22	peak
4	2400.000	13.60	30.87	44.47	54.00	-9.53	AVG
5	2419.500	66.93	30.92	97.85	/	/	peak
6	2419.500	57.32	30.92	88.24	/	/	AVG

The test result is calculated as the following:

- (1) Result = Reading + Correct Factor
- (2) Correct Factor = Antenna Factor + Cable Loss – Amplifier Gain + Attenuator
- (3) Margin = Result - Limit

EUT:	8" Android Tablet	Model No.:	SE-ET8
Temperature:	24	Relative Humidity:	55%
Distance:	3m	Test Power:	DC 3.8V
Polarization:	Horizontal	Test Result:	Pass
Test Time:	2018-9-22	Test By:	Smile
Standard:	FCC PART 15 C 1-26.5G PEAK		
Test Mode:	TX		
Note:	G 2462		

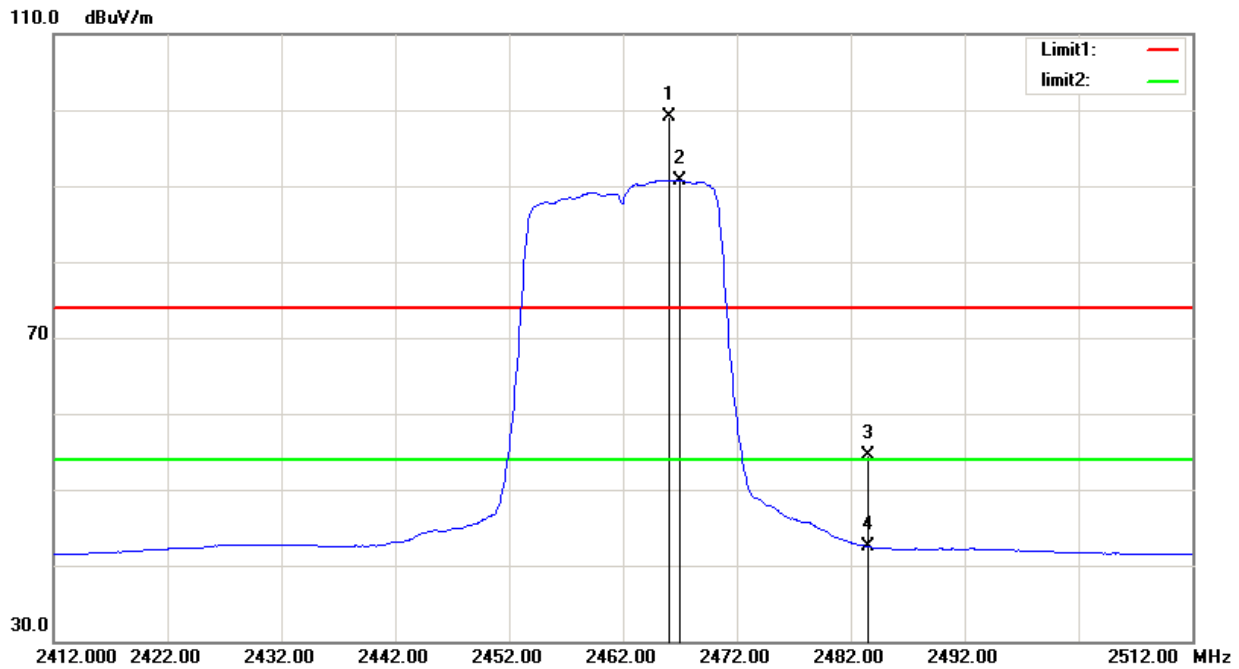

No.	Frequency (MHz)	Reading (dBuV/m)	Correct Factor (dB/m)	Result (dBuV/m)	Limit (dBuV/m)	Margin (dB)	Remark
1	2466.100	68.00	31.02	99.02	/	/	peak
2	2467.000	59.75	31.02	90.77	/	/	AVG
3	2483.500	23.53	31.07	54.60	74.00	-19.40	peak
4	2483.500	11.38	31.07	42.45	54.00	-11.55	AVG

The test result is calculated as the following:

- (1) Result = Reading + Correct Factor
- (2) Correct Factor = Antenna Factor + Cable Loss – Amplifier Gain + Attenuator
- (3) Margin = Result - Limit

EUT:	8" Android Tablet	Model No.:	SE-ET8
Temperature:	24	Relative Humidity:	55%
Distance:	3m	Test Power:	DC 3.8V
Polarization:	Vertical	Test Result:	Pass
Test Time:	2018-9-22	Test By:	Smile
Standard:	FCC PART 15 C 1-26.5G PEAK		
Test Mode:	TX		
Note:	G 2462		

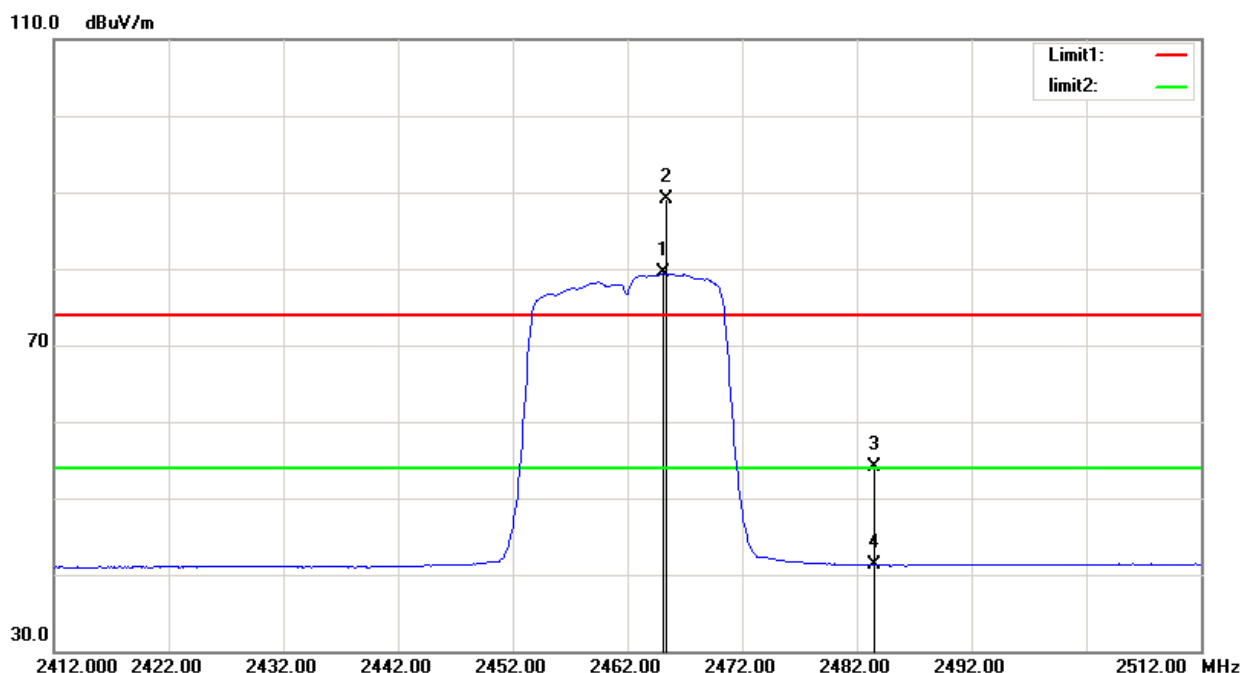

No.	Frequency (MHz)	Reading (dBuV/m)	Correct Factor(dB/m)	Result (dBuV/m)	Limit (dBuV/m)	Margin (dB)	Remark
1	2465.100	48.39	31.02	79.41	/	/	AVG
2	2465.400	58.02	31.02	89.04	/	/	peak
3	2483.500	23.01	31.07	54.08	74.00	-19.92	peak
4	2483.500	10.21	31.07	41.28	54.00	-12.72	AVG

The test result is calculated as the following:

- (1) Result = Reading + Correct Factor
- (2) Correct Factor = Antenna Factor + Cable Loss – Amplifier Gain + Attenuator
- (3) Margin = Result - Limit

EUT:	8" Android Tablet	Model No.:	SE-ET8
Temperature:	24	Relative Humidity:	55%
Distance:	3m	Test Power:	DC 3.8V
Polarization:	Vertical	Test Result:	Pass
Test Time:	2018-9-22	Test By:	Smile
Standard:	FCC PART 15 C 1-26.5G PEAK		
Test Mode:	TX		
Note:	N20 2412		

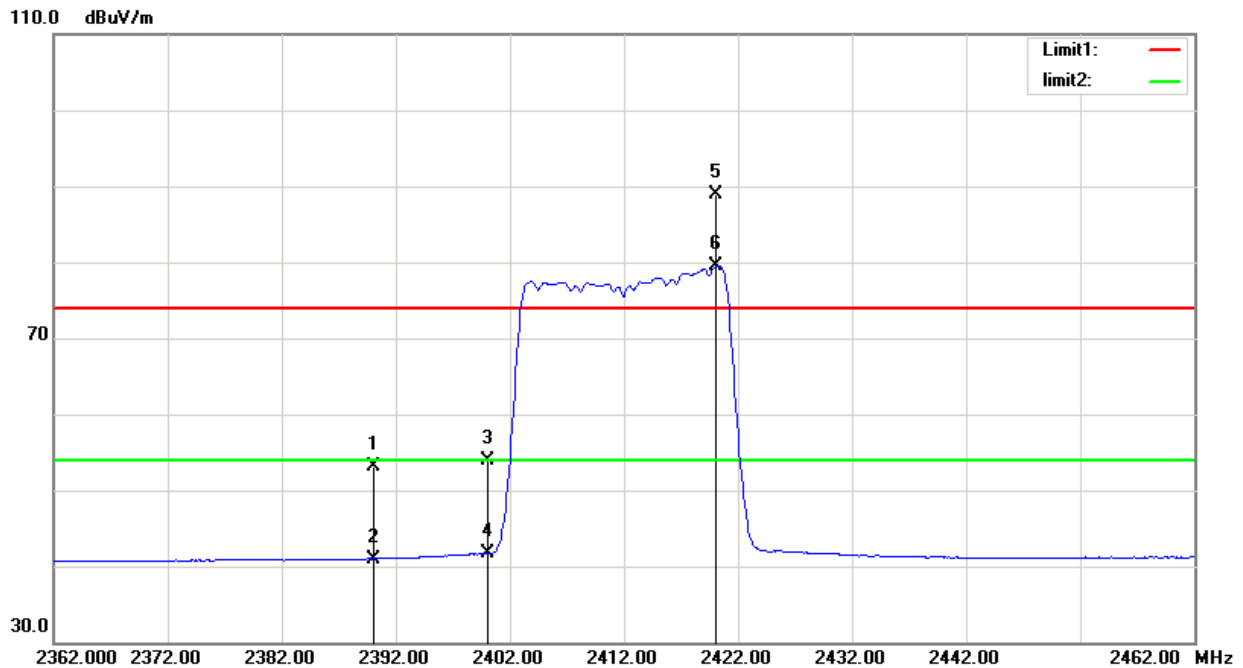

No.	Frequency (MHz)	Reading (dBuV/m)	Correct Factor(dB/m)	Result (dBuV/m)	Limit (dBuV/m)	Margin (dB)	Remark
1	2390.000	22.33	30.85	53.18	74.00	-20.82	peak
2	2390.000	10.14	30.85	40.99	54.00	-13.01	AVG
3	2400.000	22.96	30.87	53.83	74.00	-20.17	peak
4	2400.000	10.83	30.87	41.70	54.00	-12.30	AVG
5	2420.100	58.03	30.92	88.95	/	/	peak
6	2420.100	48.55	30.92	79.47	/	/	AVG

The test result is calculated as the following:

- (1) Result = Reading + Correct Factor
- (2) Correct Factor = Antenna Factor + Cable Loss – Amplifier Gain + Attenuator
- (3) Margin = Result - Limit

EUT:	8" Android Tablet	Model No.:	SE-ET8
Temperature:	24	Relative Humidity:	55%
Distance:	3m	Test Power:	DC 3.8V
Polarization:	Horizontal	Test Result:	Pass
Test Time:	2018-9-22	Test By:	Smile
Standard:	FCC PART 15 C 1-26.5G PEAK		
Test Mode:	TX		
Note:	N20 2412		

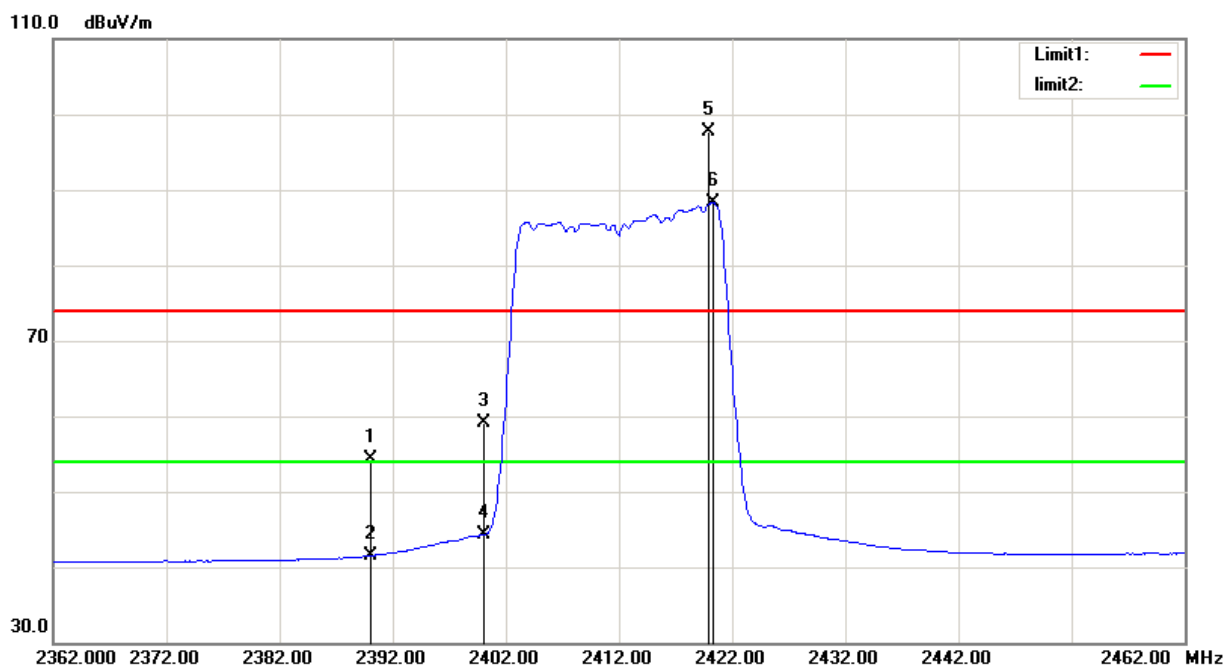

No.	Frequency (MHz)	Reading (dBuV/m)	Correct Factor (dB/m)	Result (dBuV/m)	Limit (dBuV/m)	Margin (dB)	Remark
1	2390.000	23.43	30.85	54.28	74.00	-19.72	peak
2	2390.000	10.72	30.85	41.57	54.00	-12.43	AVG
3	2400.000	28.15	30.87	59.02	74.00	-14.98	peak
4	2400.000	13.43	30.87	44.30	54.00	-9.70	AVG
5	2419.900	66.84	30.92	97.76	/	/	peak
6	2420.300	57.30	30.92	88.22	/	/	AVG

The test result is calculated as the following:

- (1) Result = Reading + Correct Factor
- (2) Correct Factor = Antenna Factor + Cable Loss – Amplifier Gain + Attenuator
- (3) Margin = Result - Limit

EUT:	8" Android Tablet	Model No.:	SE-ET8
Temperature:	24	Relative Humidity:	55%
Distance:	3m	Test Power:	DC 3.8V
Polarization:	Horizontal	Test Result:	Pass
Test Time:	2018-9-22	Test By:	Smile
Standard:	FCC PART 15 C 1-26.5G PEAK		
Test Mode:	TX		
Note:	N20 2462		

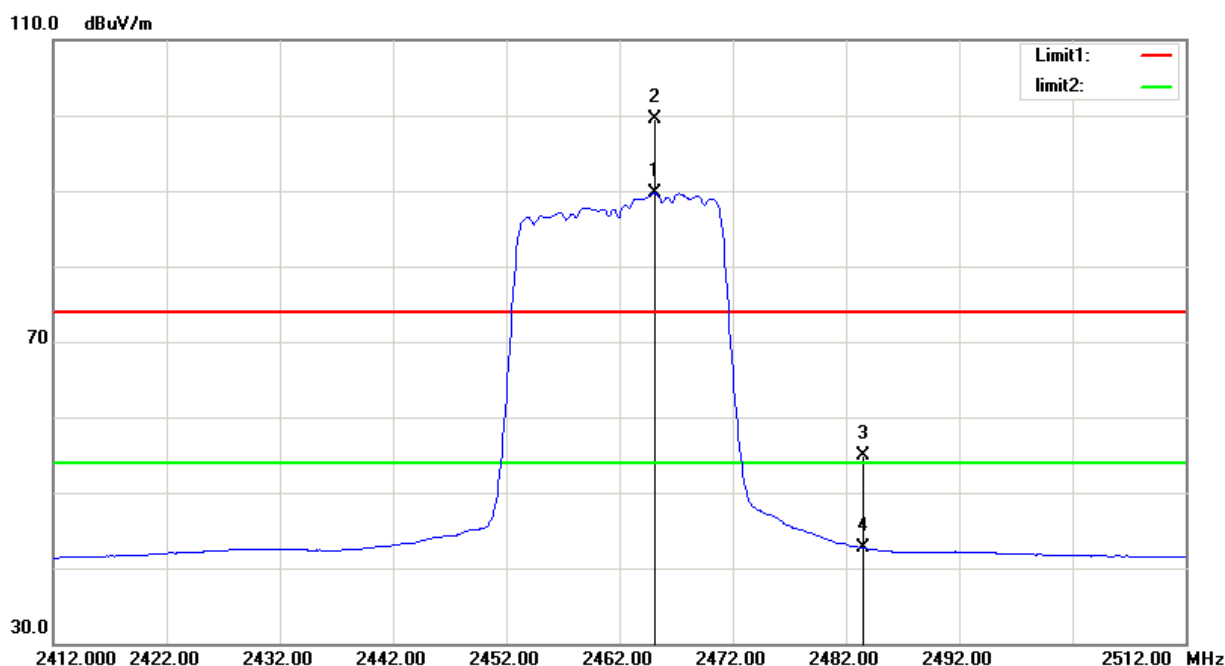

No.	Frequency (MHz)	Reading (dBuV/m)	Correct Factor(dB/m)	Result (dBuV/m)	Limit (dBuV/m)	Margin (dB)	Remark
1	2465.100	58.65	31.02	89.67	/	/	AVG
2	2465.200	68.51	31.02	99.53	/	/	peak
3	2483.500	23.82	31.07	54.89	74.00	-19.11	peak
4	2483.500	11.60	31.07	42.67	54.00	-11.33	AVG

The test result is calculated as the following:

- (1) Result = Reading + Correct Factor
- (2) Correct Factor = Antenna Factor + Cable Loss – Amplifier Gain + Attenuator
- (3) Margin = Result - Limit

EUT:	8" Android Tablet	Model No.:	SE-ET8
Temperature:	24	Relative Humidity:	55%
Distance:	3m	Test Power:	DC 3.8V
Polarization:	Vertical	Test Result:	Pass
Test Time:	2018-9-22	Test By:	Smile
Standard:	FCC PART 15 C 1-26.5G PEAK		
Test Mode:	TX		
Note:	N20 2462		

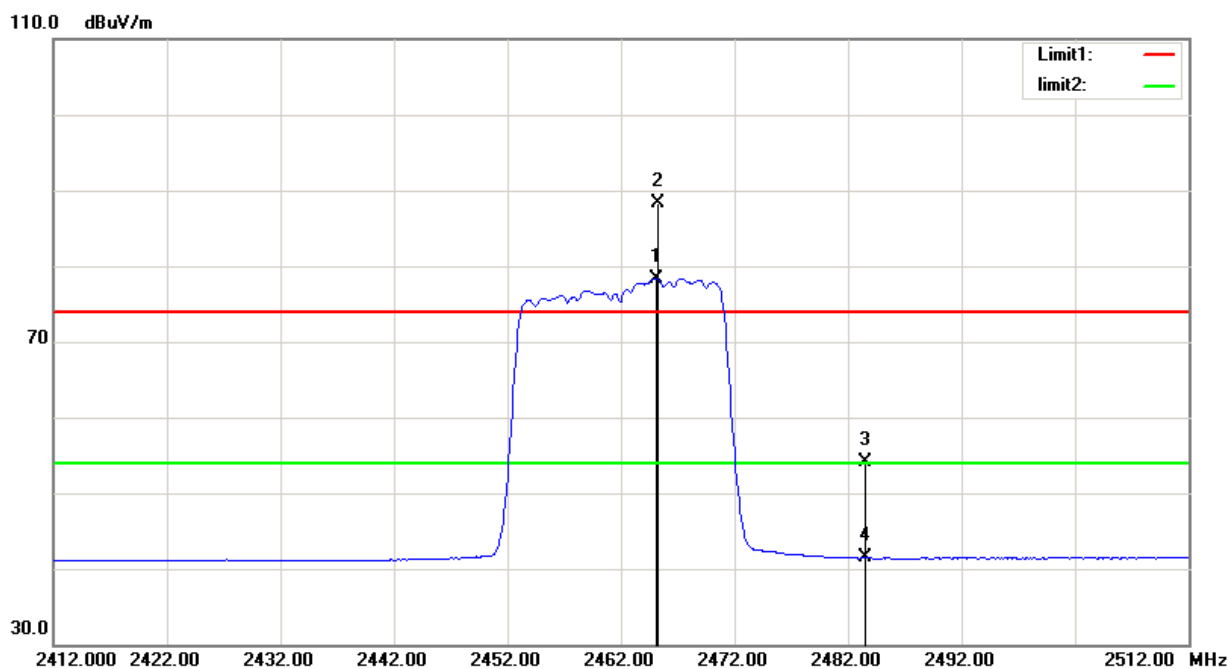

No.	Frequency (MHz)	Reading (dBuV/m)	Correct Factor (dB/m)	Result (dBuV/m)	Limit (dBuV/m)	Margin (dB)	Remark
1	2465.100	47.35	31.02	78.37	/	/	AV
2	2465.300	57.19	31.02	88.21	/	/	peak
3	2483.500	23.02	31.07	54.09	74.00	-19.91	peak
4	2483.500	10.34	31.07	41.41	74.00	-32.59	AV

The test result is calculated as the following:

- (1) Result = Reading + Correct Factor
- (2) Correct Factor = Antenna Factor + Cable Loss – Amplifier Gain + Attenuator
- (3) Margin = Result - Limit

EUT:	8" Android Tablet	Model No.:	SE-ET8
Temperature:	24	Relative Humidity:	55%
Distance:	3m	Test Power:	DC 3.8V
Polarization:	Vertical	Test Result:	Pass
Test Time:	2018-9-22	Test By:	Smile
Standard:	FCC PART 15 C 1-26.5G PEAK		
Test Mode:	TX		
Note:	N40 2422		

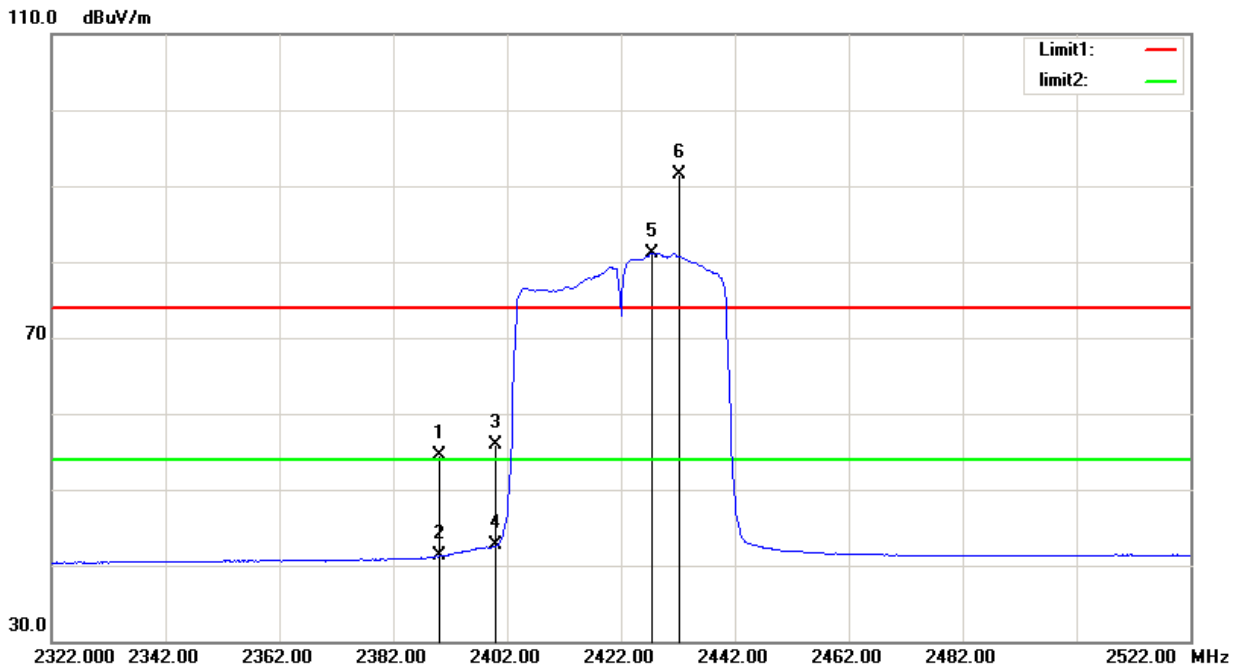

No.	Frequency (MHz)	Reading (dBuV/m)	Correct Factor (dB/m)	Result (dBuV/m)	Limit (dBuV/m)	Margin (dB)	Remark
1	2390.000	23.57	30.85	54.42	74.00	-19.58	peak
2	2390.000	10.36	30.85	41.21	54.00	-12.79	AVG
3	2400.000	25.04	30.87	55.91	74.00	-18.09	peak
4	2400.000	11.73	30.87	42.60	54.00	-11.40	AVG
5	2427.600	50.19	30.94	81.13	/	/	AVG
6	2432.200	60.55	30.94	91.49	/	/	peak

The test result is calculated as the following:

- (1) Result = Reading + Correct Factor
- (2) Correct Factor = Antenna Factor + Cable Loss – Amplifier Gain + Attenuator
- (3) Margin = Result - Limit

EUT:	8" Android Tablet	Model No.:	SE-ET8
Temperature:	24	Relative Humidity:	55%
Distance:	3m	Test Power:	DC 3.8V
Polarization:	Horizontal	Test Result:	Pass
Test Time:	2018-9-22	Test By:	Smile
Standard:	FCC PART 15 C 1-26.5G PEAK		
Test Mode:	TX		
Note:	N40 2422		

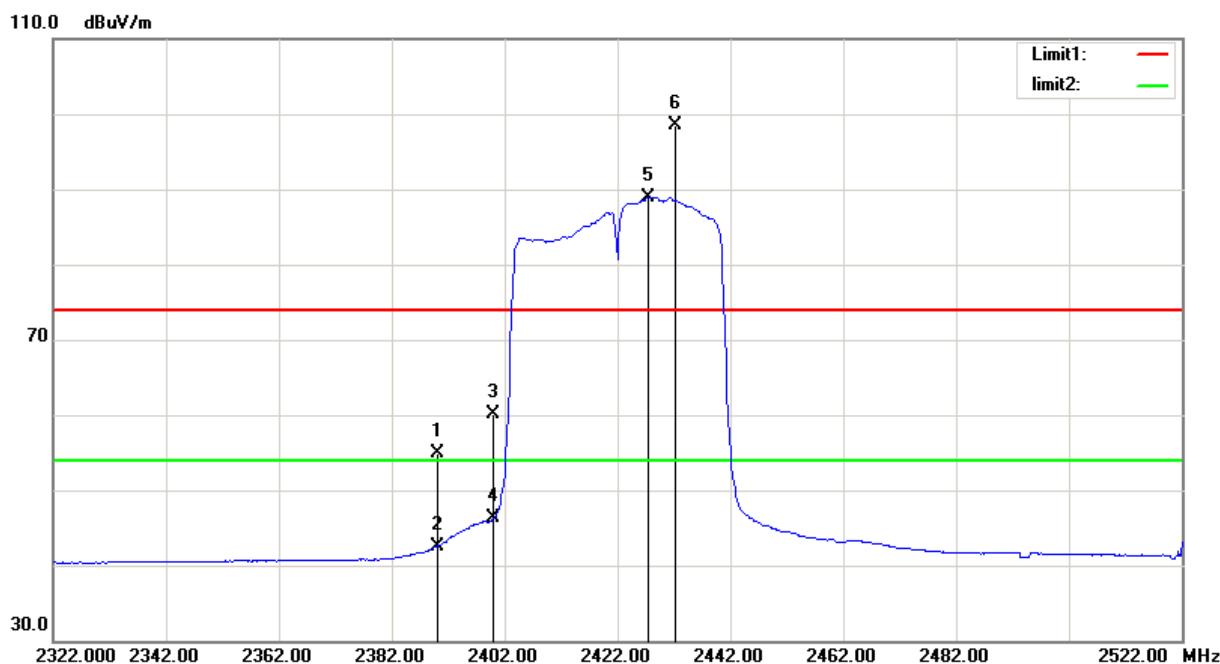

No.	Frequency (MHz)	Reading (dBuV/m)	Correct Factor (dB/m)	Result (dBuV/m)	Limit (dBuV/m)	Margin (dB)	Remark
1	2390.000	24.02	30.85	54.87	74.00	-19.13	peak
2	2390.000	11.72	30.85	42.57	54.00	-11.43	AVG
3	2400.000	29.26	30.87	60.13	74.00	-13.87	peak
4	2400.000	15.35	30.87	46.22	54.00	-7.78	AVG
5	2427.600	58.03	30.94	88.97	/	/	AVG
6	2432.200	67.63	30.94	98.57	/	/	peak

The test result is calculated as the following:

- (1) Result = Reading + Correct Factor
- (2) Correct Factor = Antenna Factor + Cable Loss – Amplifier Gain + Attenuator
- (3) Margin = Result - Limit

EUT:	8" Android Tablet	Model No.:	SE-ET8
Temperature:	24	Relative Humidity:	55%
Distance:	3m	Test Power:	DC 3.8V
Polarization:	Horizontal	Test Result:	Pass
Test Time:	2018-9-22	Test By:	Smile
Standard:	FCC PART 15 C 1-26.5G PEAK		
Test Mode:	TX		
Note:	N40 2452		

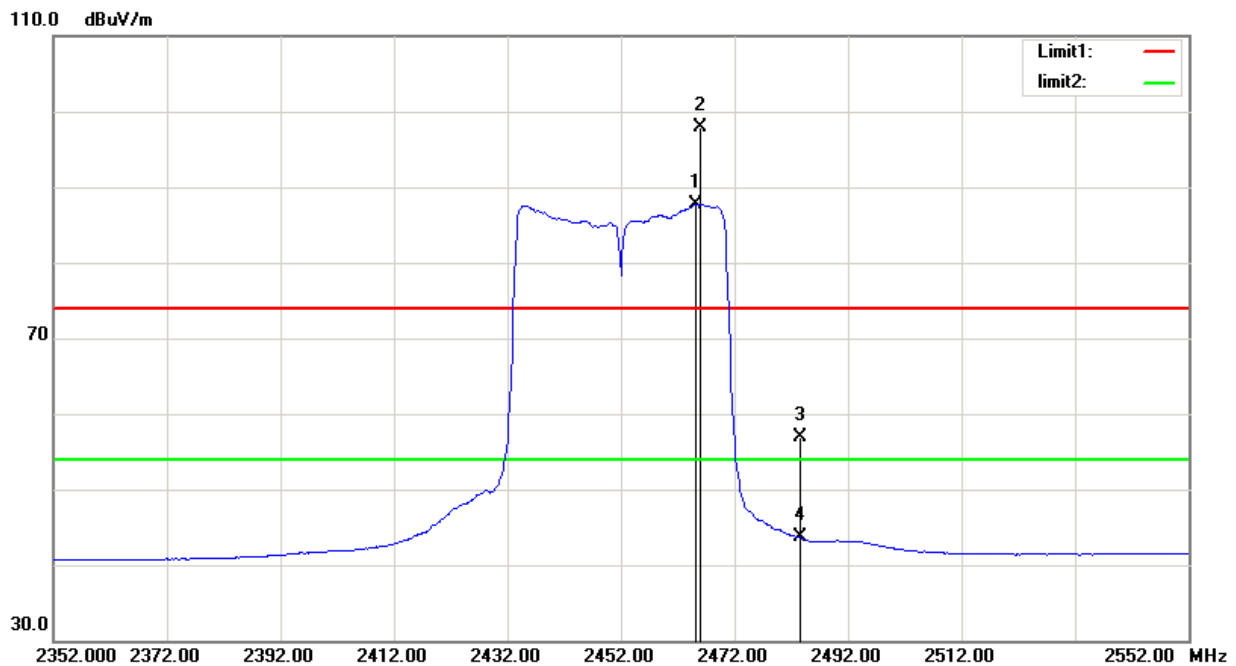

No.	Frequency (MHz)	Reading (dBuV/m)	Correct Factor(dB/m)	Result (dBuV/m)	Limit (dBuV/m)	Margin (dB)	Remark
1	2465.200	56.71	31.02	87.73	/	/	AVG
2	2466.000	66.98	31.02	98.00	/	/	peak
3	2483.500	25.87	31.07	56.94	74.00	-17.06	peak
4	2483.500	12.57	31.07	43.64	54.00	-10.36	AVG

The test result is calculated as the following:

- (1) Result = Reading + Correct Factor
- (2) Correct Factor = Antenna Factor + Cable Loss – Amplifier Gain + Attenuator
- (3) Margin = Result - Limit

EUT:	8" Android Tablet	Model No.:	SE-ET8
Temperature:	24	Relative Humidity:	55%
Distance:	3m	Test Power:	DC 3.8V
Polarization:	Vertical	Test Result:	Pass
Test Time:	2018-9-22	Test By:	Smile
Standard:	FCC PART 15 C 1-26.5G PEAK		
Test Mode:	TX		
Note:	N40 2452		

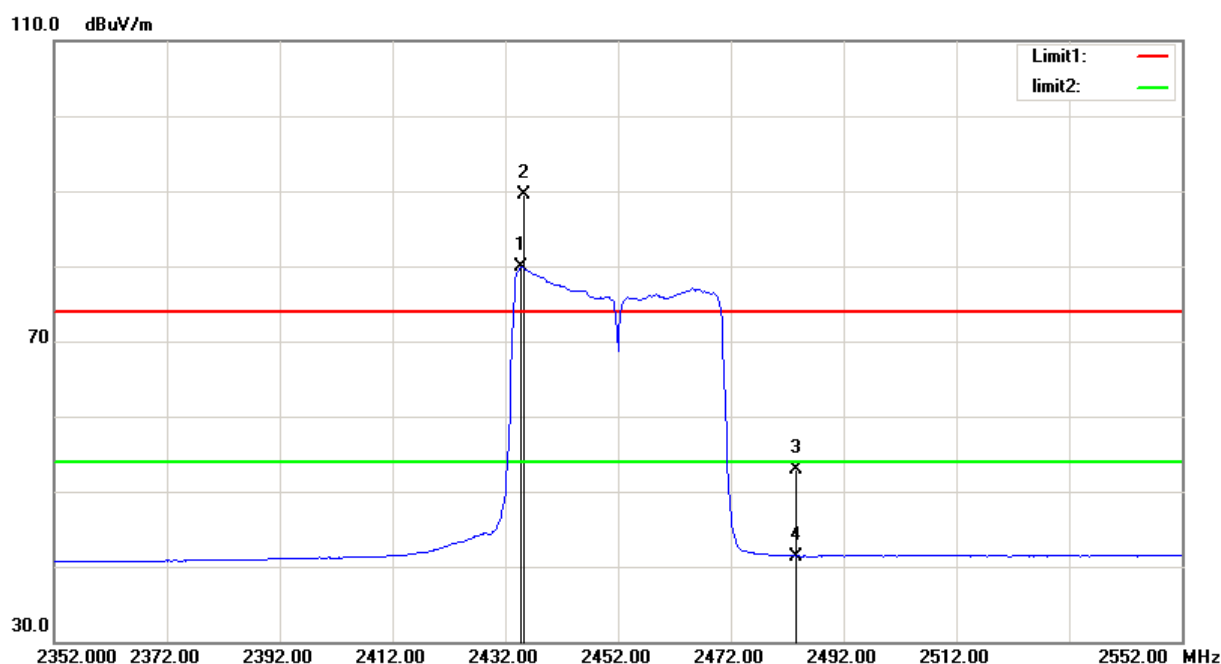

No.	Frequency (MHz)	Reading (dBuV/m)	Correct Factor (dB/m)	Result (dBuV/m)	Limit (dBuV/m)	Margin (dB)	Remark
1	2434.800	48.86	30.95	79.81	/	/	AVG
2	2435.400	58.60	30.95	89.55	/	/	peak
3	2483.500	21.82	31.07	52.89	74.00	-21.11	peak
4	2483.500	10.32	31.07	41.39	54.00	-12.61	AVG

The test result is calculated as the following:

- (1) Result = Reading + Correct Factor
- (2) Correct Factor = Antenna Factor + Cable Loss – Amplifier Gain + Attenuator
- (3) Margin = Result - Limit

7. 100 kHz Bandwidth of Frequency Band Edge

7.1. Test equipment

Item	Equipment	Manufacturer	Model No.	Serial No.	Calibrated until	Calibrated Date
1	Spectrum analyzer	KEYSIGHT	N9010A	MY55150427	05/25/2019	05/26/2018
2	Attenuator	Mini-Circuits	BW-S10W2	101109	12/17/2018	12/18/2017
3	RF Cable	Micable	C10-01-01-1	100309	12/17/2018	12/18/2017

7.2. Block diagram of test setup

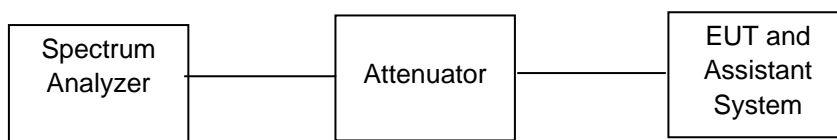

7.3. Limit

In any 100 kHz bandwidth outside the frequency band in which the spread spectrum or digitally modulated intentional radiator is operating, the radio frequency power that is produced by the intentional radiator shall be at least 20 dB below that in the 100 kHz bandwidth within the band that contains the highest level of the desired power, based on either an RF conducted or a radiated measurement, provided the transmitter demonstrates compliance with the peak conducted power limits. If the transmitter complies with the conducted power limits based on the use of RMS averaging over a time interval, as permitted under paragraph (b)(3) of this section, the attenuation required under this paragraph shall be 30 dB instead of 20 dB. Attenuation below the general limits specified in §15.209(a) is not required. In addition, radiated emissions which fall in the restricted bands, as defined in §15.205(a), must also comply with the radiated emission limits specified in §15.209(a) (see §15.205(c)).

7.4. Test Procedure

1. Check the calibration of the measuring instrument using either an internal calibrator or a known signal from an external generator.
2. Remove the antenna from the EUT and then connect to a low loss RF cable from the antenna port to a EMI test receiver, then turn on the EUT and make it operate in transmitting mode. Then set it to Low Channel and High Channel within its operating range, and make sure the instrument is operated in its linear range.
3. Set both RBW and VBW of spectrum analyzer to 100 kHz with a convenient frequency span including 100 kHz bandwidth from band edge.
4. Measure the highest amplitude appearing on spectral display and set it as a reference level. Plot the graph with marking the highest point and edge frequency.
5. Repeat above procedures until all measured frequencies were complete.

7.5. Test result

PASS

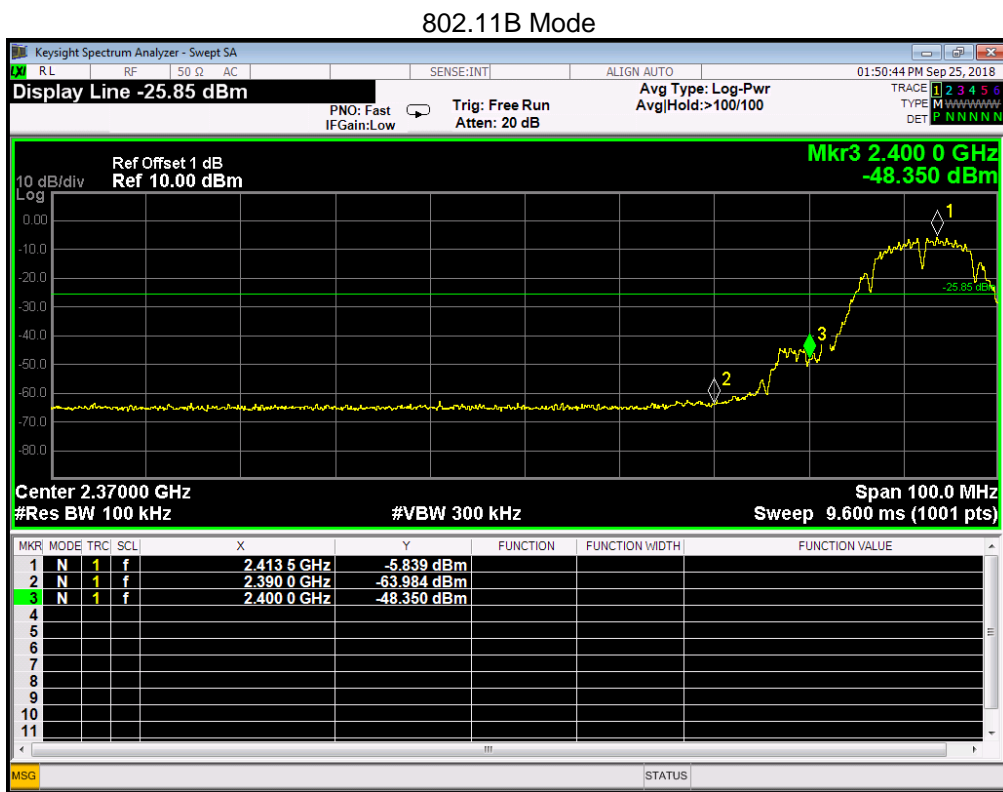

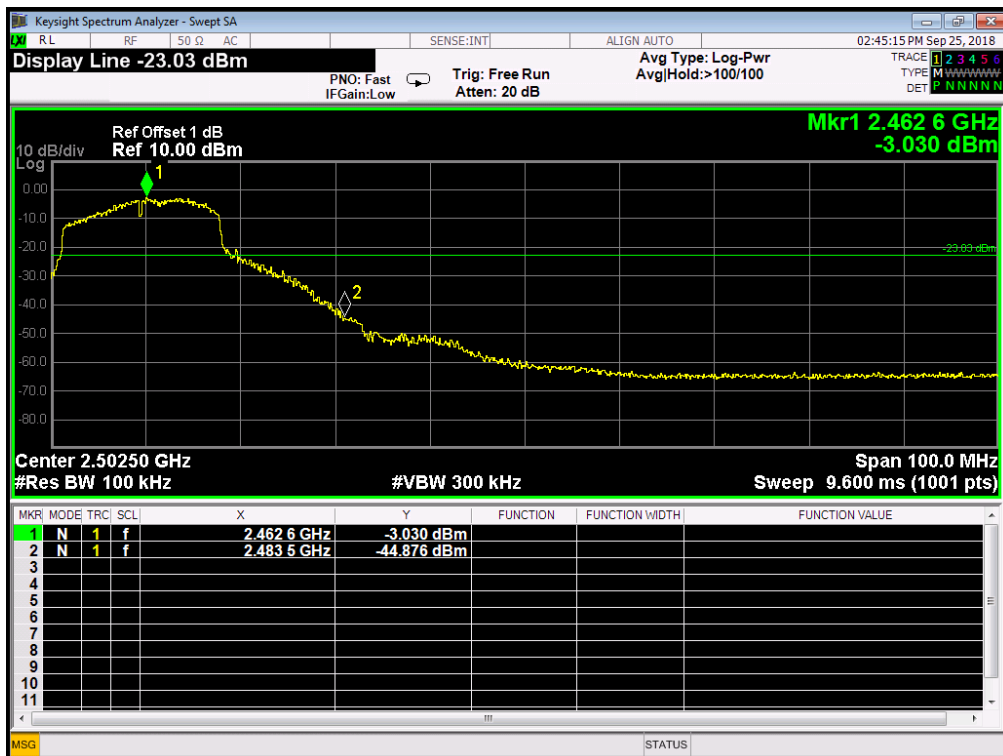
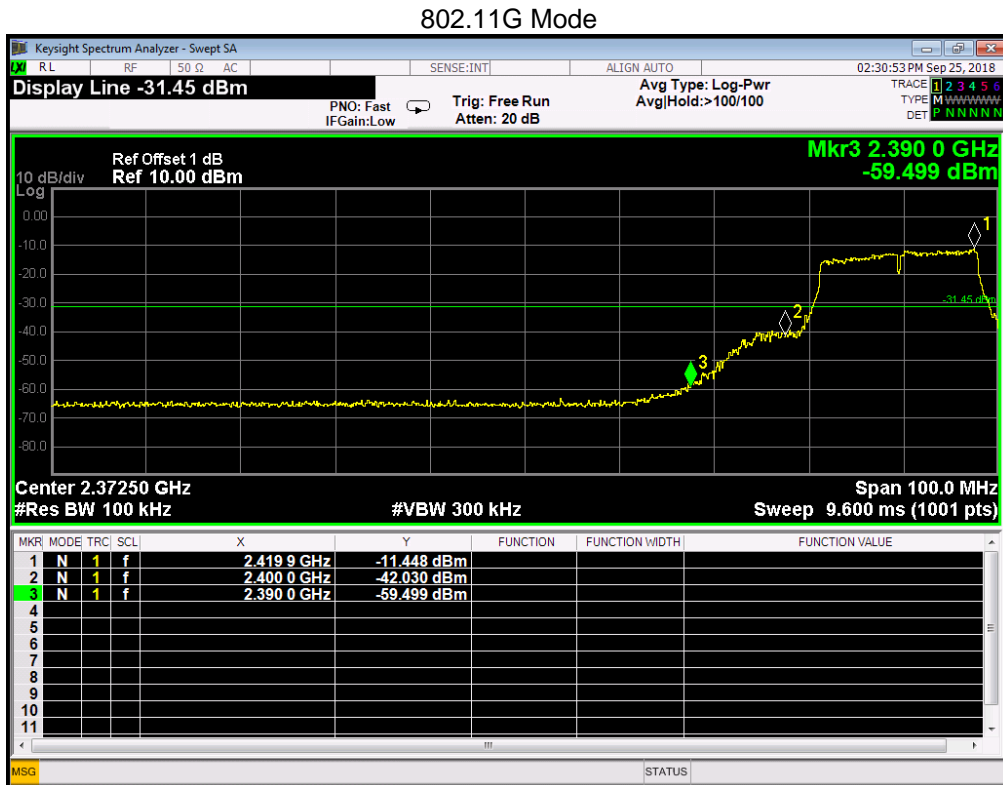

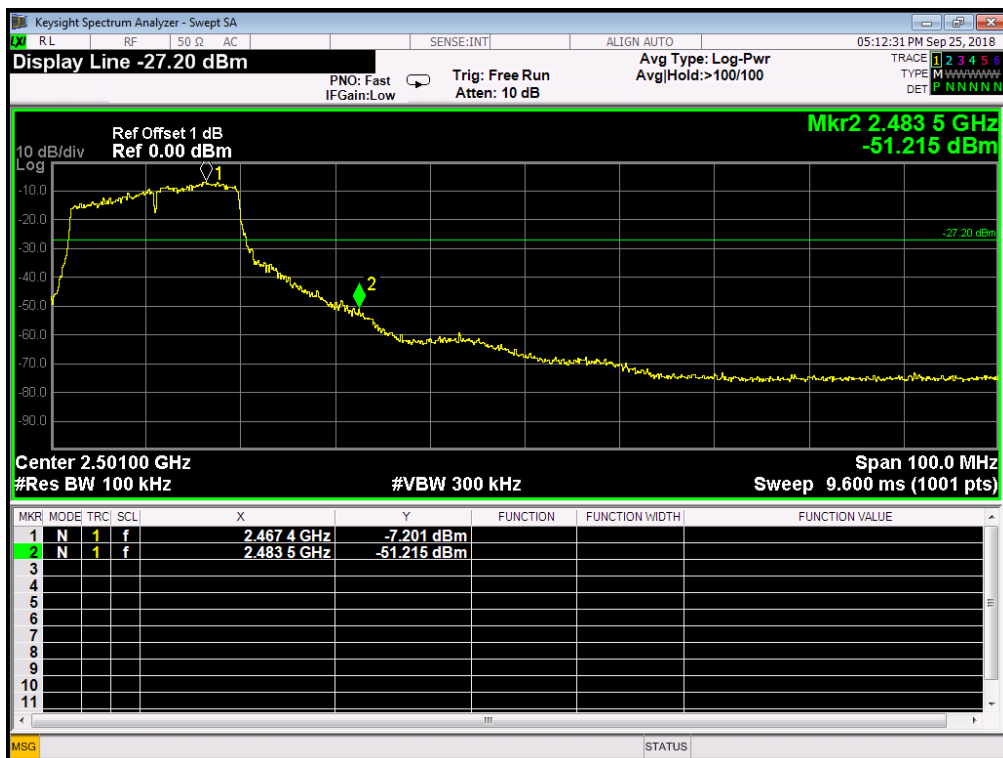
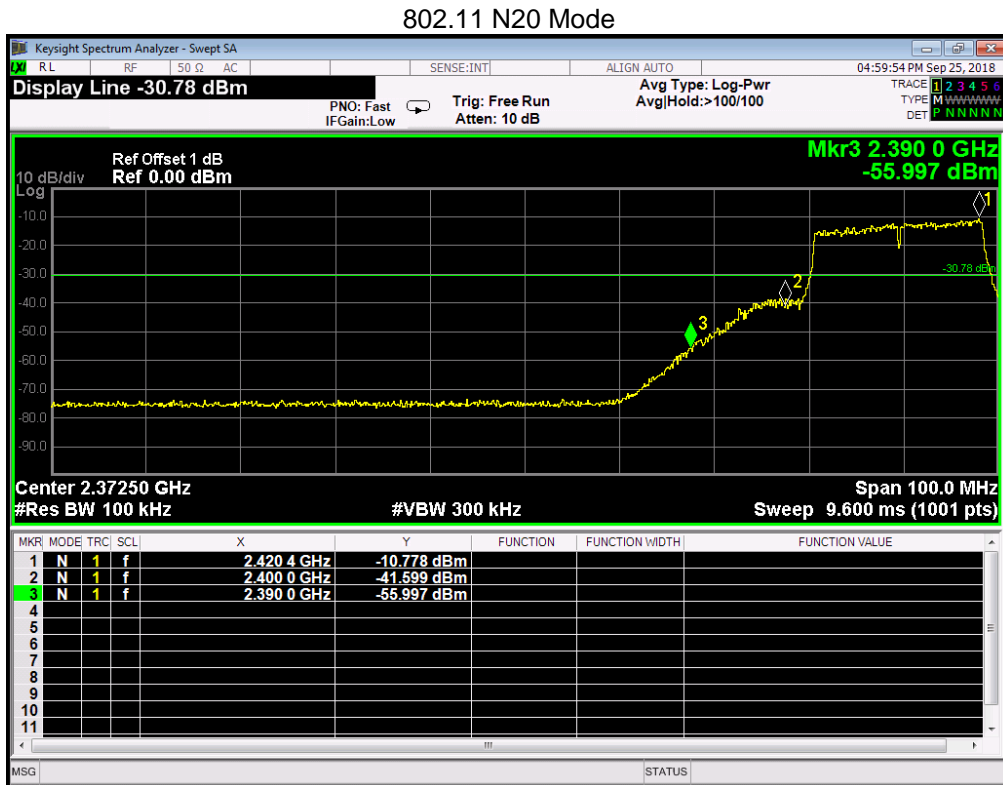

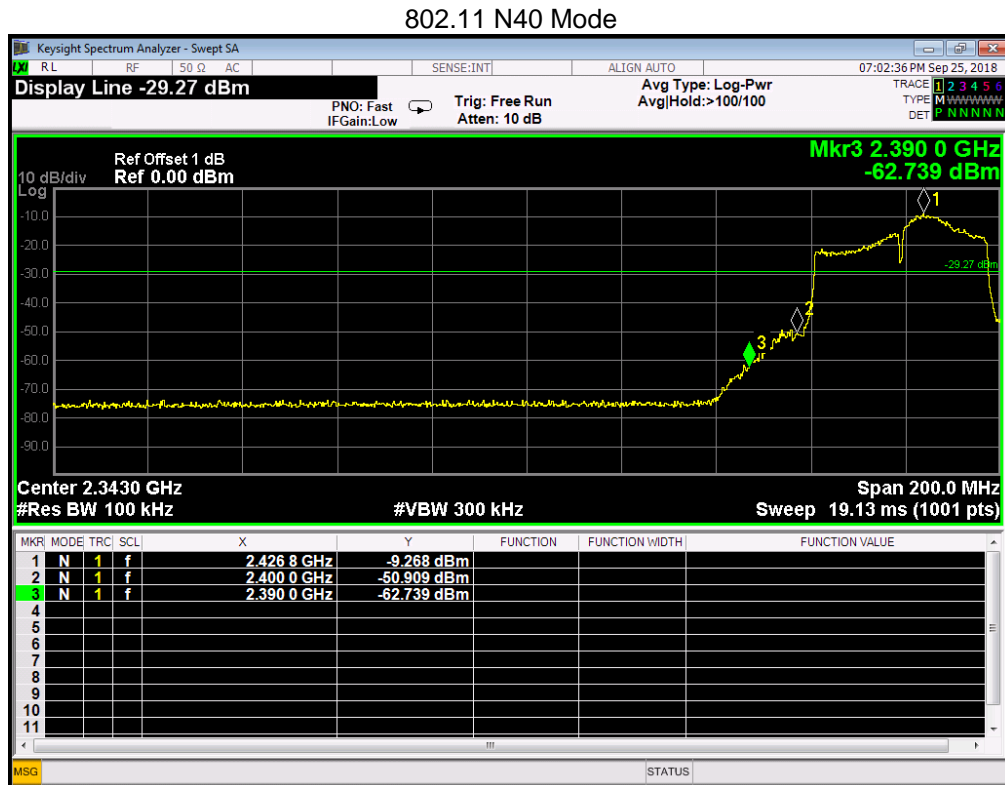

8. Conducted Spurious Emissions

8.1. Test Equipment

Item	Equipment	Manufacturer	Model No.	Serial No.	Calibrated until	Calibrated Date
1	Spectrum analyzer	KEYSIGHT	N9010A	MY55150427	05/25/2019	05/26/2018
2	Attenuator	Mini-Circuits	BW-S10W2	101109	12/17/2018	12/18/2017
3	RF Cable	Micable	C10-01-01-1	100309	12/17/2018	12/18/2017

8.2. Limit

In any 100kHz bandwidth outside the frequency bands in which the spread spectrum intentional radiator is operating, the radio frequency power that is produced by the intentional radiator shall be at least 20dB below that in the 100kHz bandwidth within the band that contains the highest level of the desired power.

8.3. Test Procedure

The transmitter output was connected to a spectrum analyzer, The resolution bandwidth is set to 100 kHz, The video bandwidth is set to 300 kHz and measure all the emissions detected.

8.4. Test result

PASS (See below detailed test result.)

802.11 B Mode CH1

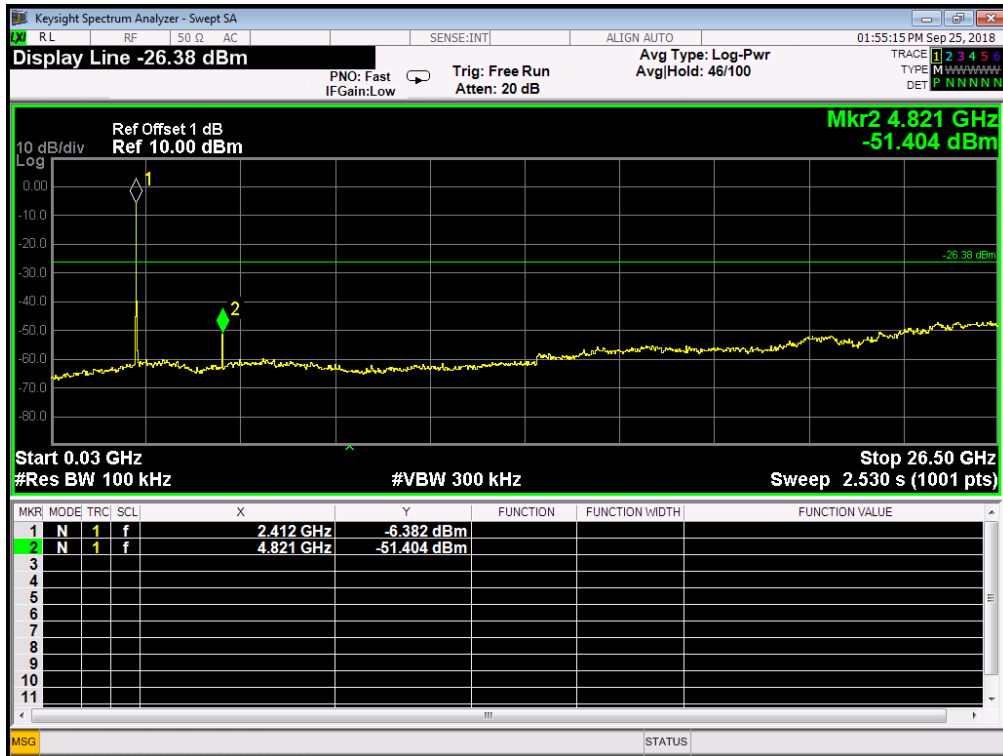

802.11 B Mode CH6

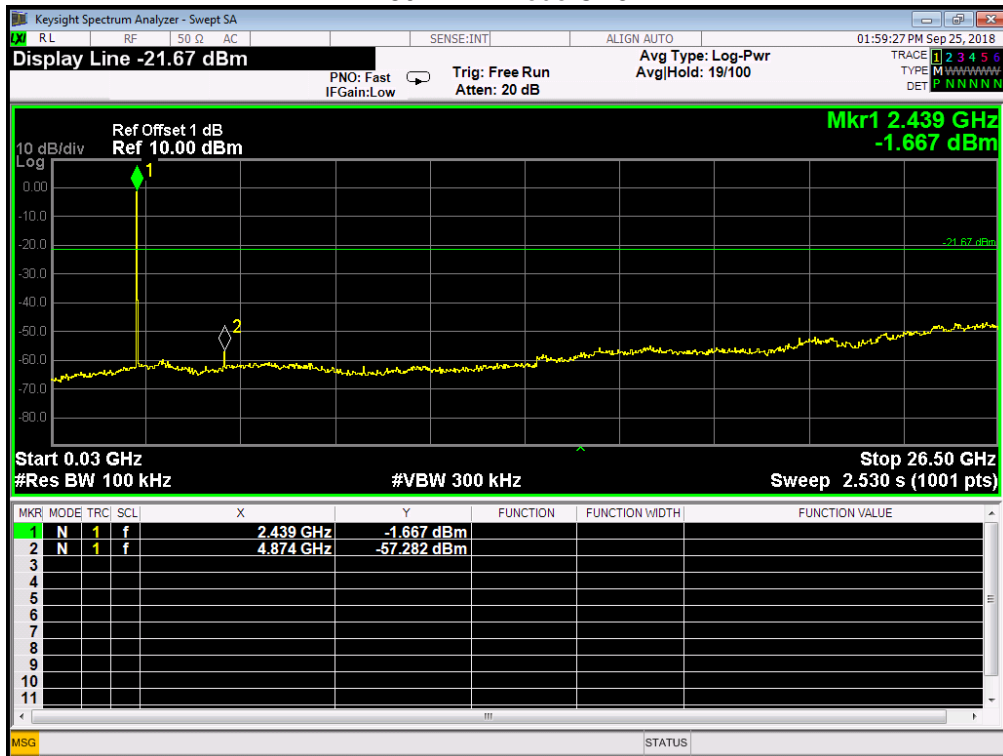

802.11 B Mode CH11

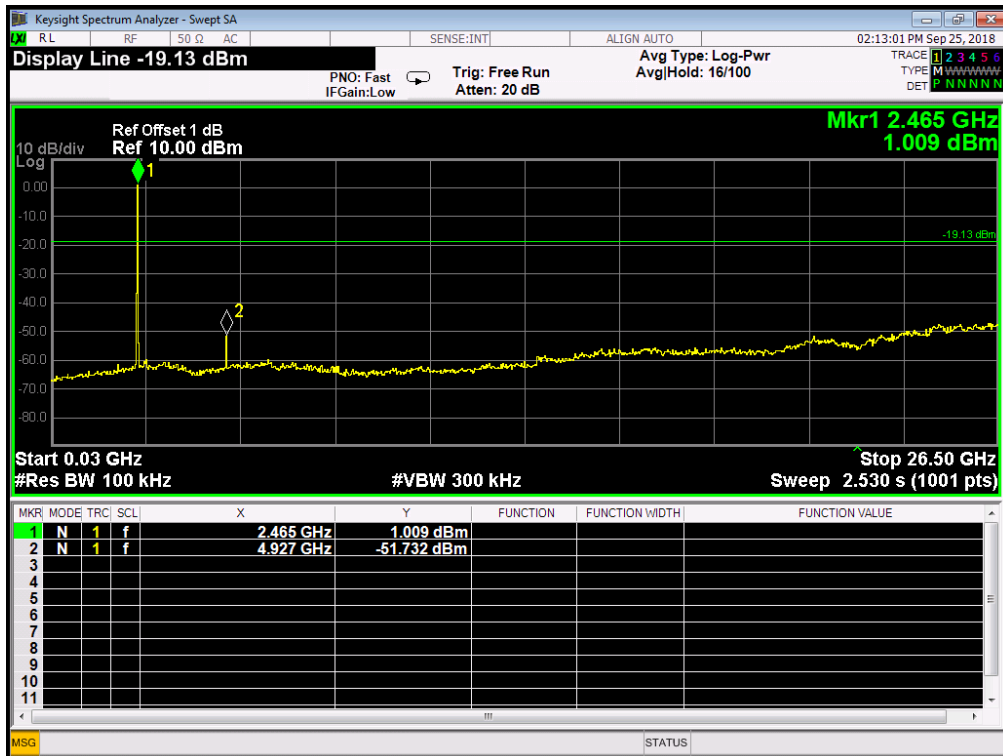

802.11 G Mode CH1

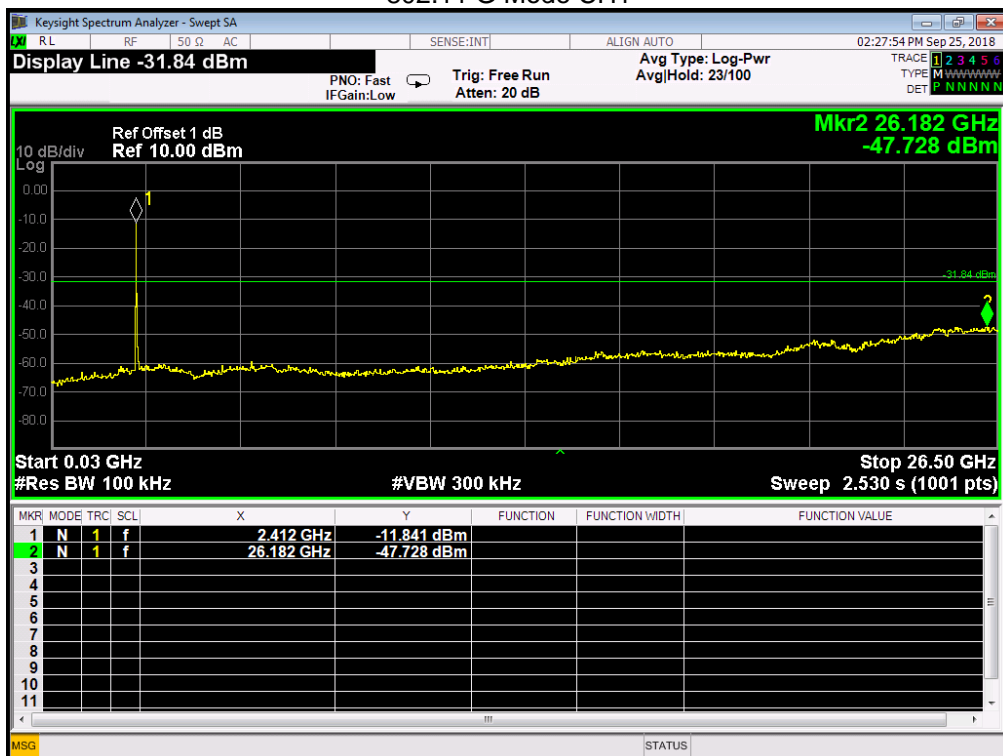

802.11 G Mode CH6

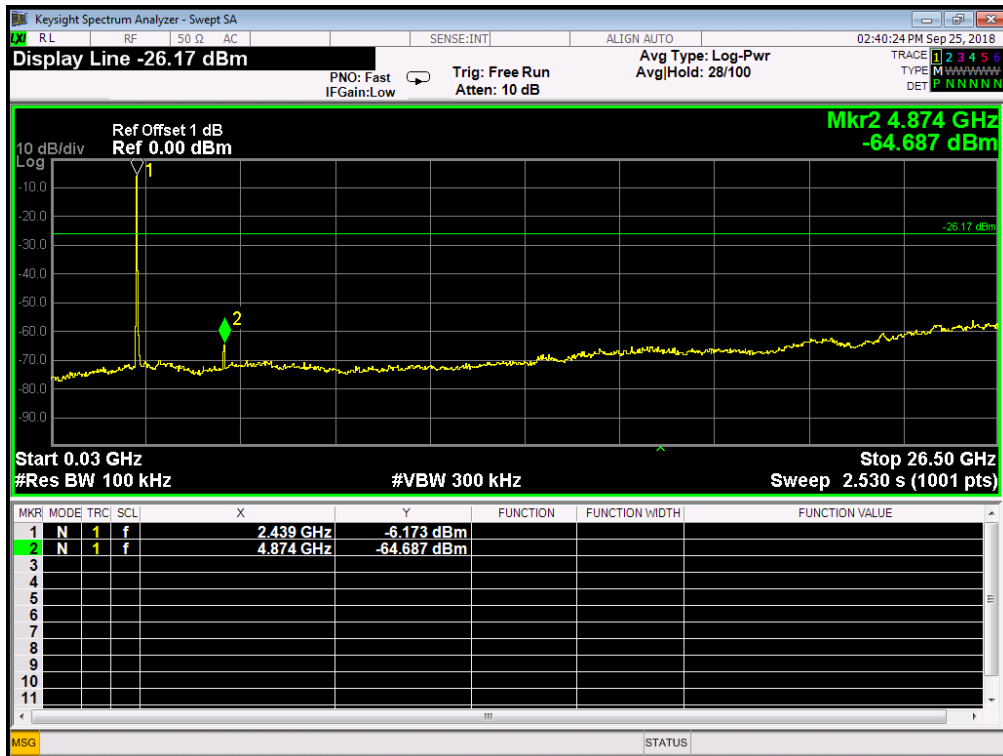

802.11 G Mode CH11

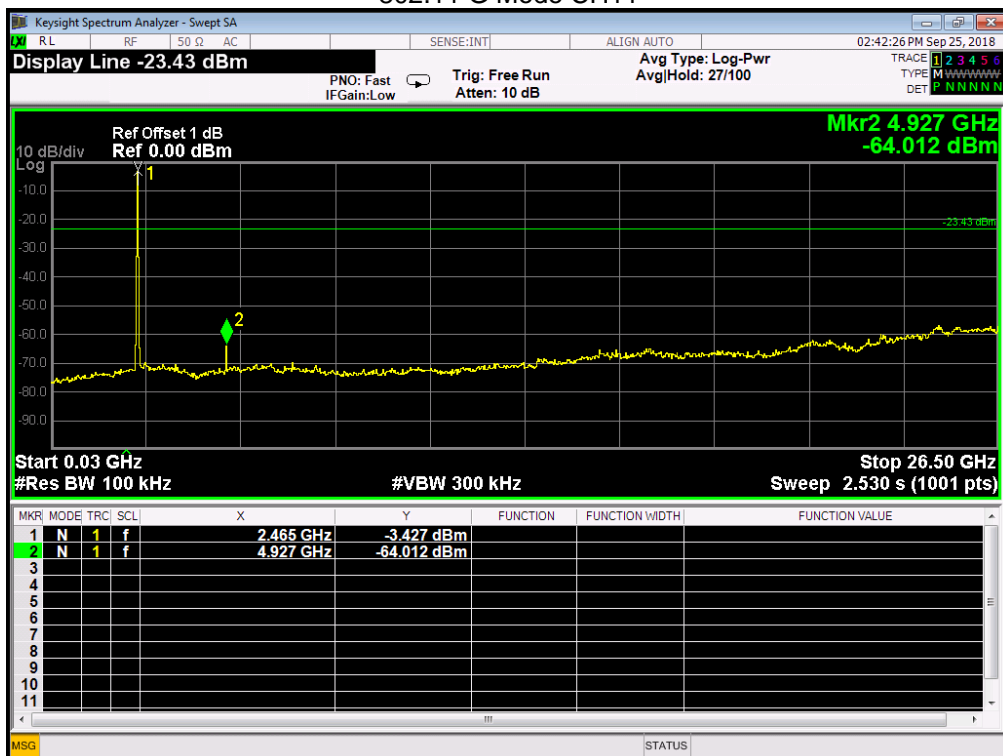

802.11 N20 Mode CH1

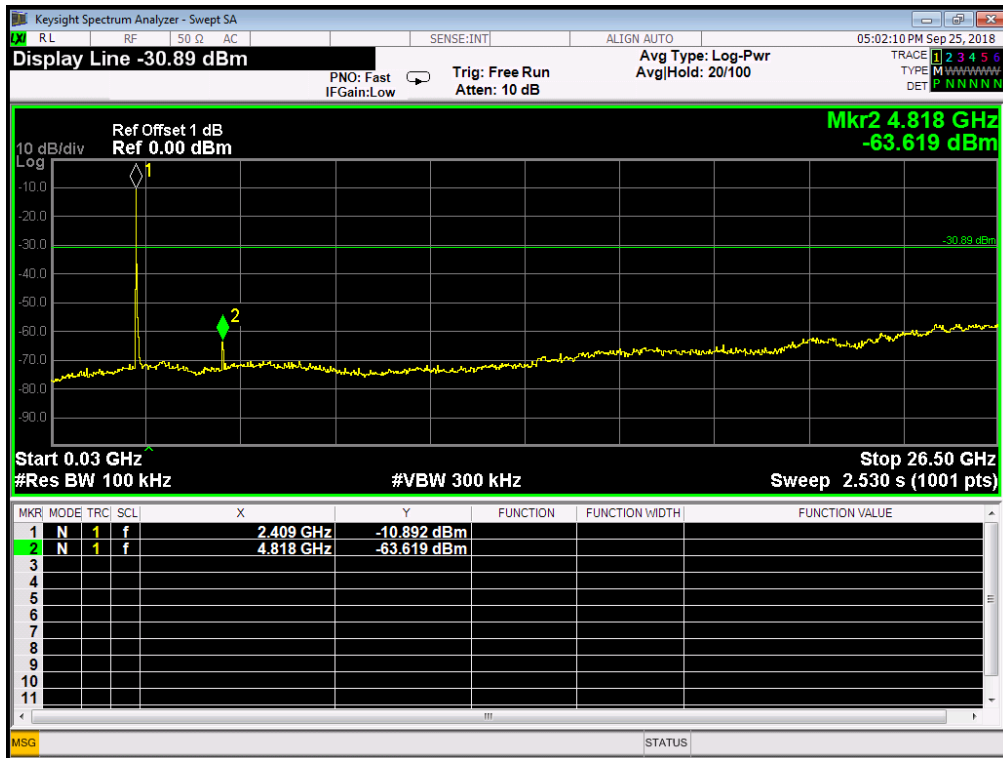

802.11 N20 Mode CH6

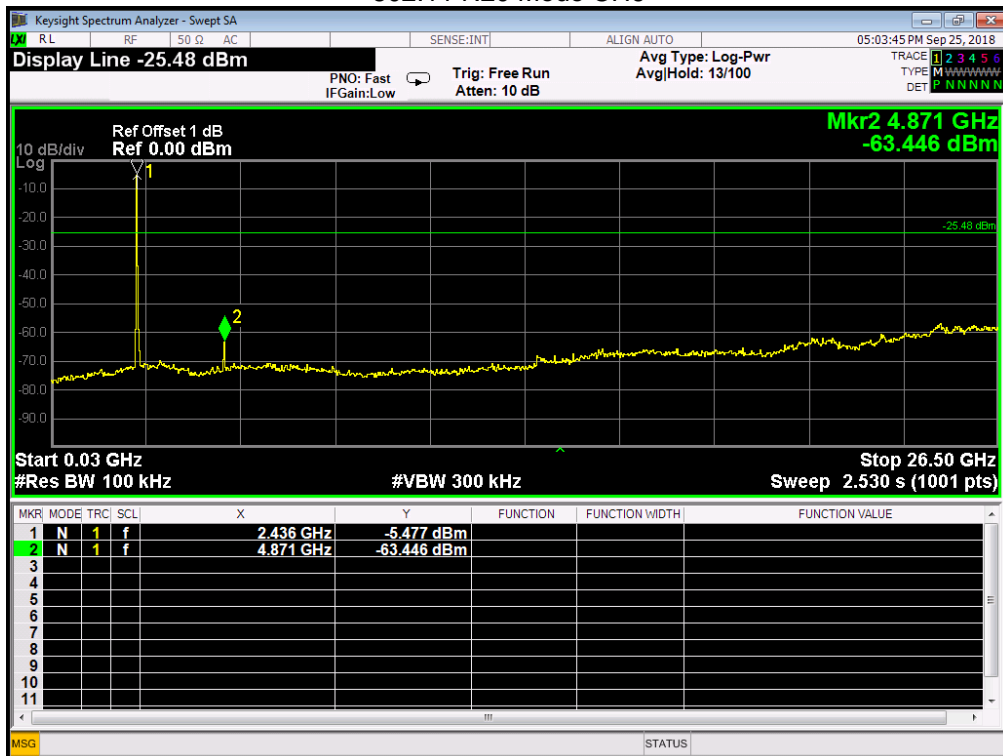

802.11 N20 Mode CH11

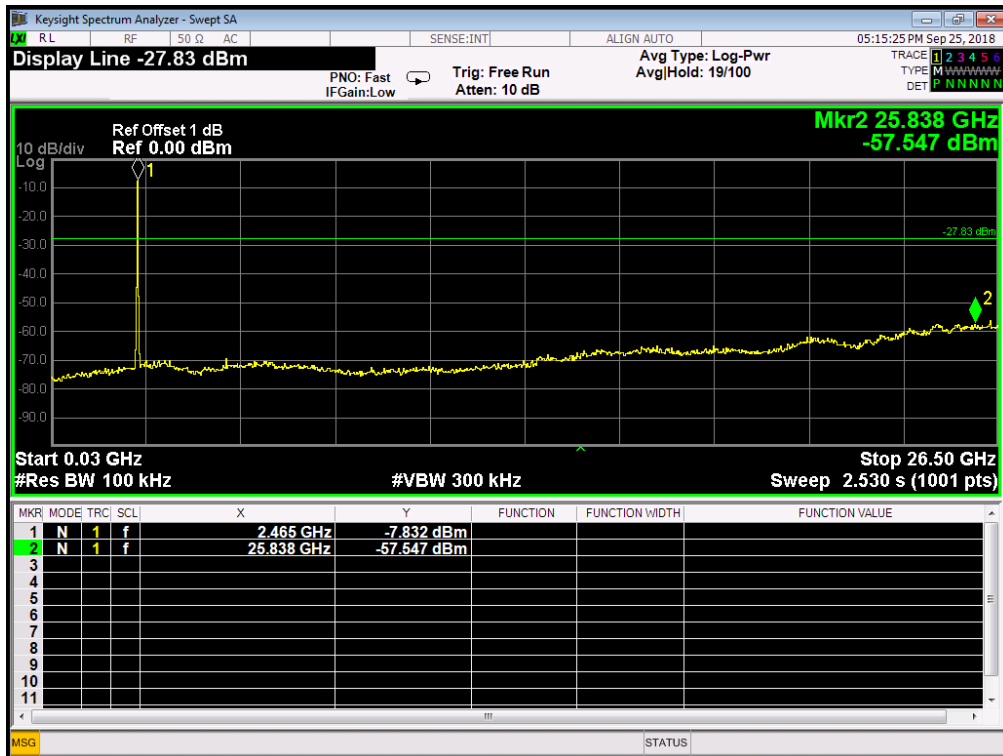

802.11 N40 Mode CH3

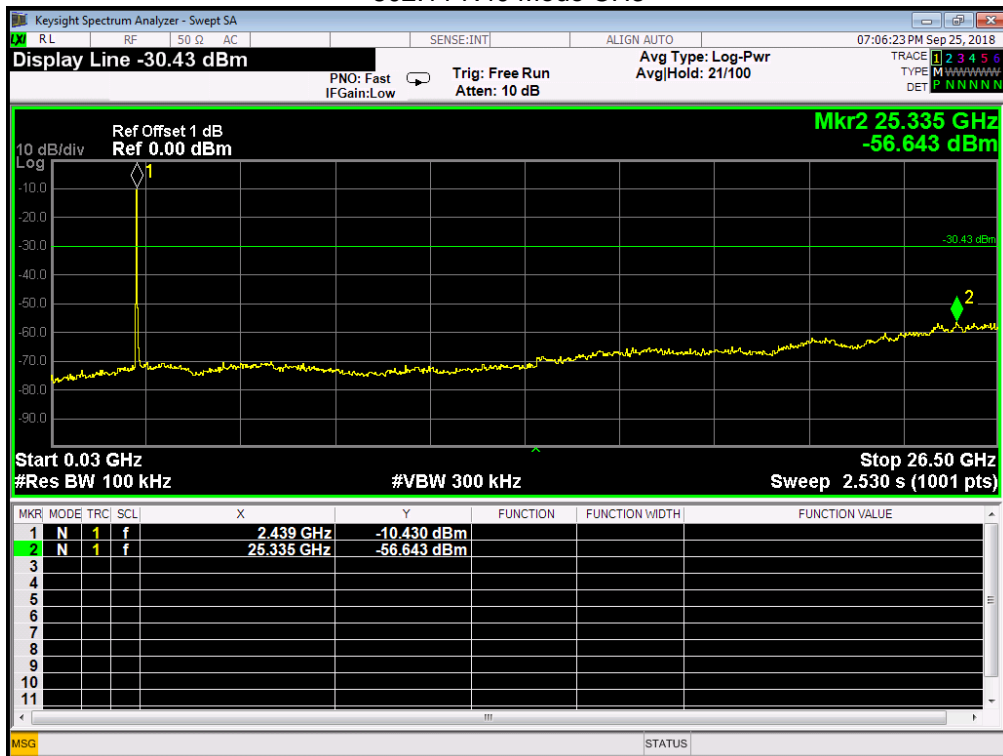

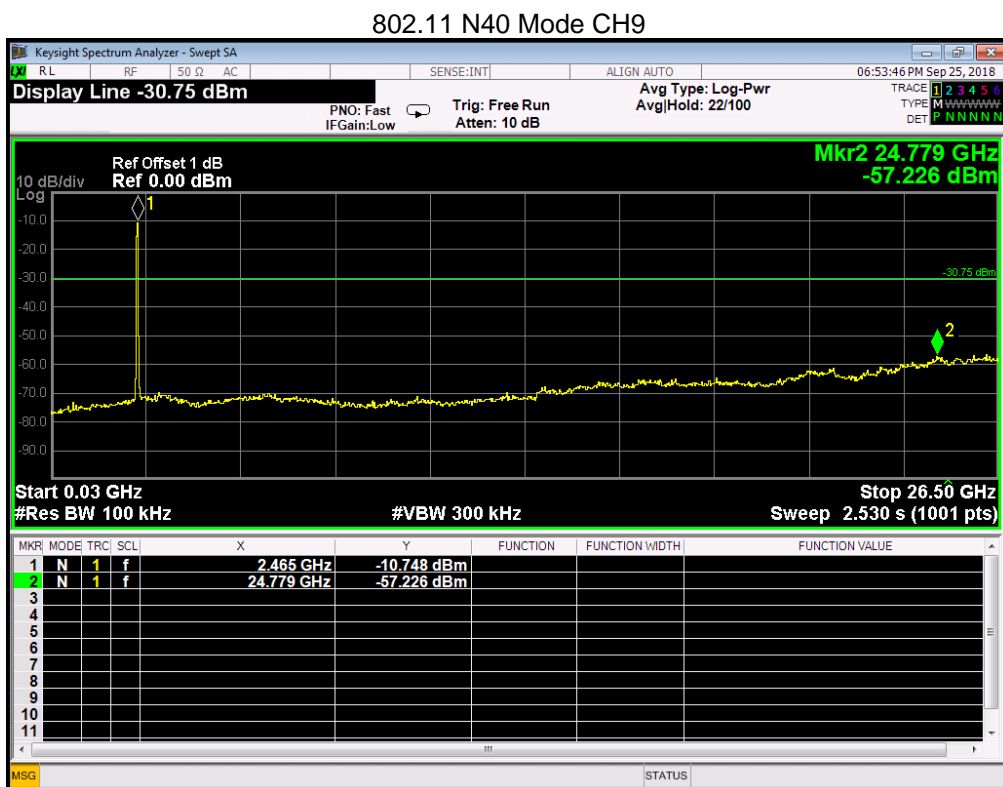
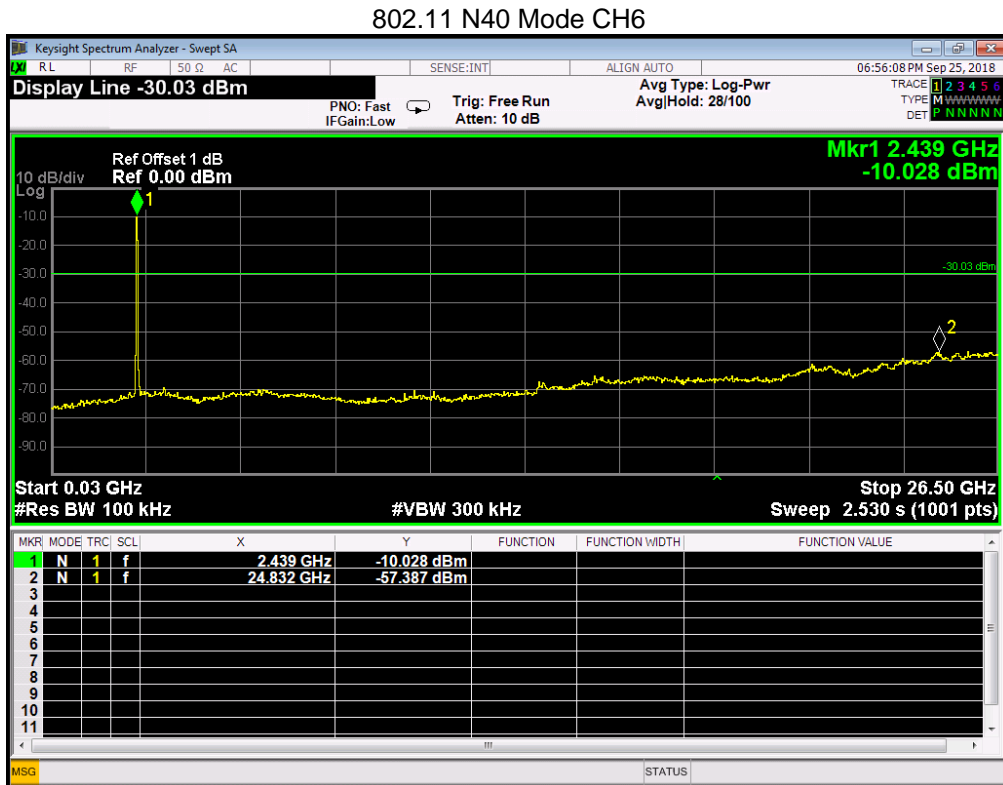

9 Power Line Conducted Emission

9.1 Test equipment

Item	Kind of Equipment	Manufacturer	Type No.	Serial No.	Calibrated until
1	Pulse Limiter	MTS-systemtechnik	MTS-IMP-136	261115-010-0024	12/17/2018
2	EMI Test Receiver	R&S	ESCI	101308	12/17/2018
3	LISN	AFJ	LS16	16011103219	12/17/2018
4	LISN	Schwarzbeck	NSLK 8127	8127-432	12/17/2018
5	Measurement Software	Farad	EZ-EMC (Ver.ATT-03A)	N/A	N/A
6	MeasurementSoftware	Farad	EZ-EMC (Ver.ATT-03A)	N/A	N/A

9.2 Block diagram of test setup

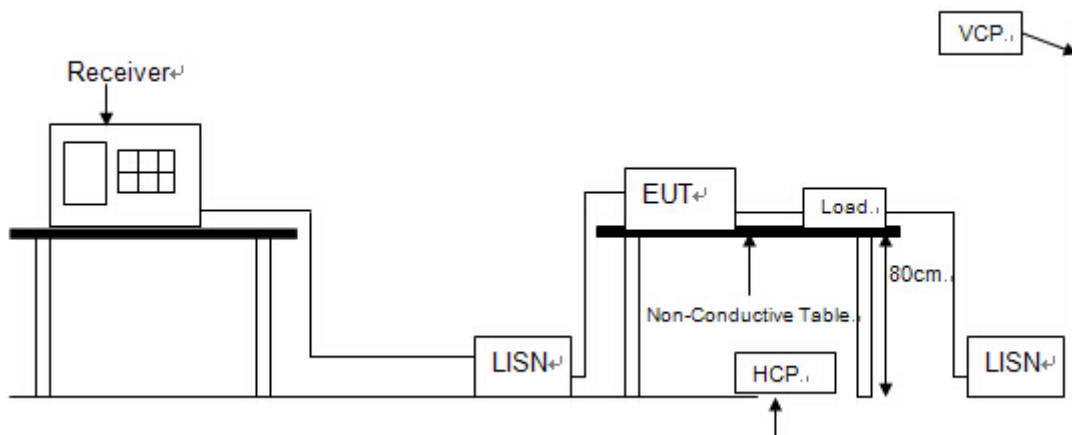

9.3 Power Line Conducted Emission Limits(Class B)

Frequency	Quasi-Peak Level dB(μ V)	Average Level dB(μ V)
150kHz ~ 500kHz	66 ~ 56*	56 ~ 46*
500kHz ~ 5MHz	56	46
5MHz ~ 30MHz	60	50

Note 1: * Decreasing linearly with logarithm of frequency.

Note 2: The lower limit shall apply at the transition frequencies.

9.4 Test Procedure

The EUT and Support equipment, if needed, were put placed on a non-metallic table, 80cm above the ground plane.

Configuration EUT to simulate typical usage as described in clause 2.4 and test equipment as described in clause 10.2 of this report.

All I/O cables were positioned to simulate typical actual usage as per ANSI C63.4.

All support equipment power received from a second LISN.

Emissions were measured on each current carrying line of the EUT using an EMI Test Receiver connected to the LISN powering the EUT.

The Receiver scanned from 150 kHz to 30MHz for emissions in each of the test modes.

During the above scans, the emissions were maximized by cable manipulation.

The test mode(s) described in clause 2.4 were scanned during the preliminary test.

After the preliminary scan, we found the test mode producing the highest emission level.

The EUT configuration and worse cable configuration of the above highest emission levels were recorded for reference of the final test.

EUT and support equipment were set up on the test bench as per the configuration with highest emission level in the preliminary test.

A scan was taken on both power lines, Neutral and Line, recording at least the six highest emissions.

Emission frequency and amplitude were recorded into a computer in which correction factors were used to calculate the emission level and compare reading to the applicable limit.

The test data of the worst-case condition(s) was recorded.

The bandwidth of test receiver is set at 9 KHz.

9.5 Test Result

PASS. (See below detailed test result)

Note1: All emissions not reported below are too low against the prescribed limits.

Note2: “----” means peak detection; “----” mans average detection

EUT:	8" Android Tablet	Model No.:	SE-ET8
Temperature:	23°C	Relative Humidity:	52%
		Test Power:	AC 120V/60Hz
Probe:	L1	Test Result:	Pass
Test Time:	2018-9-27	Test By:	
Standard:	(CE)FCC PART 15 class B_QP		
Test Mode:	TX		
Note:			

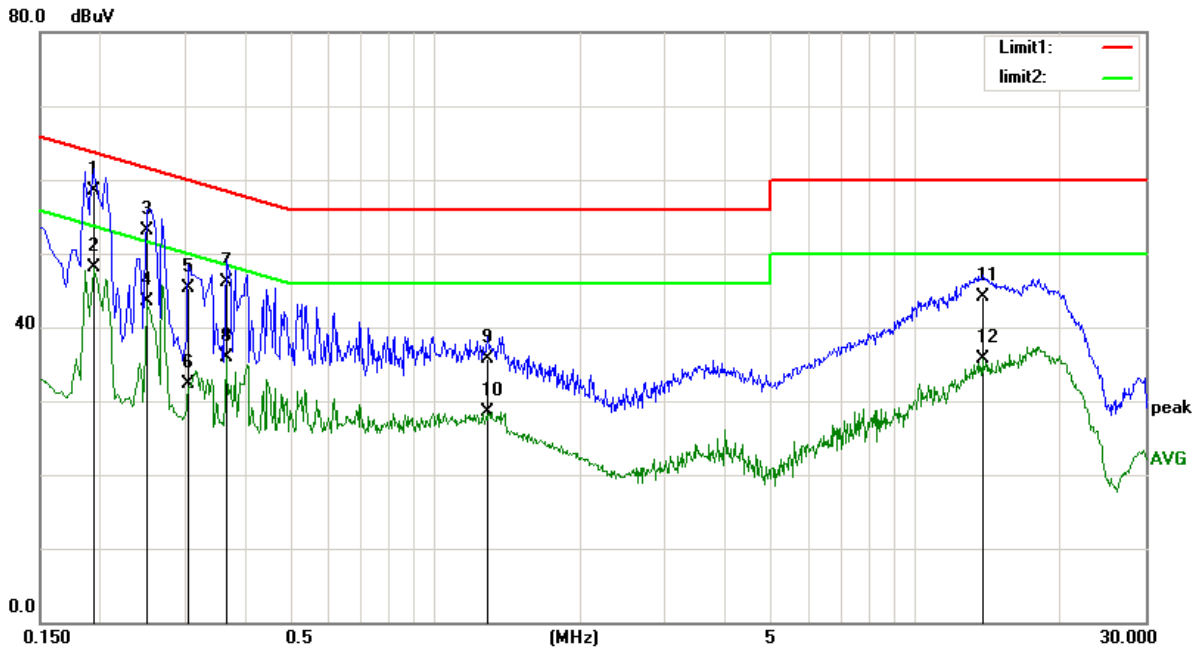

No.	Frequency (MHz)	Reading (dBuV)	Correct Factor(dB)	Result (dBuV)	Limit (dBuV)	Margin (dB)	Remark
1	0.2140	29.35	11.03	40.38	63.04	-22.66	QP
2	0.2140	13.07	11.03	24.10	53.04	-28.94	AVG
3	0.5820	26.14	10.16	36.30	56.00	-19.70	QP
4	0.5820	16.74	10.16	26.90	46.00	-19.10	AVG
5	1.0620	16.35	10.10	26.45	56.00	-29.55	QP
6	1.0620	14.07	10.10	24.17	46.00	-21.83	AVG
7	2.3220	16.97	10.12	27.09	56.00	-28.91	QP
8	2.3220	9.81	10.12	19.93	46.00	-26.07	AVG
9	6.5579	14.31	10.12	24.43	60.00	-35.57	QP
10	6.5579	5.83	10.12	15.95	50.00	-34.05	AVG
11	14.0979	16.82	10.16	26.98	60.00	-33.02	QP
12	14.0979	6.04	10.16	16.20	50.00	-33.80	AVG

The test result is calculated as the following:

- (1) Result = Reading + Correct Factor
- (2) Correct Factor = (LISN, ISN, PLC or Current Probe) Factor + Cable Loss + Attenuator
- (3) Margin = Result - Limit

EUT:	8" Android Tablet	Model No.:	SE-ET8
Temperature:	23°C	Relative Humidity:	52%
		Test Power:	AC 120V/60Hz
Probe:	N	Test Result:	Pass
Test Time:	2018-9-27	Test By:	
Standard:	(CE)FCC PART 15 class B_QP		
Test Mode:	TX		
Note:			

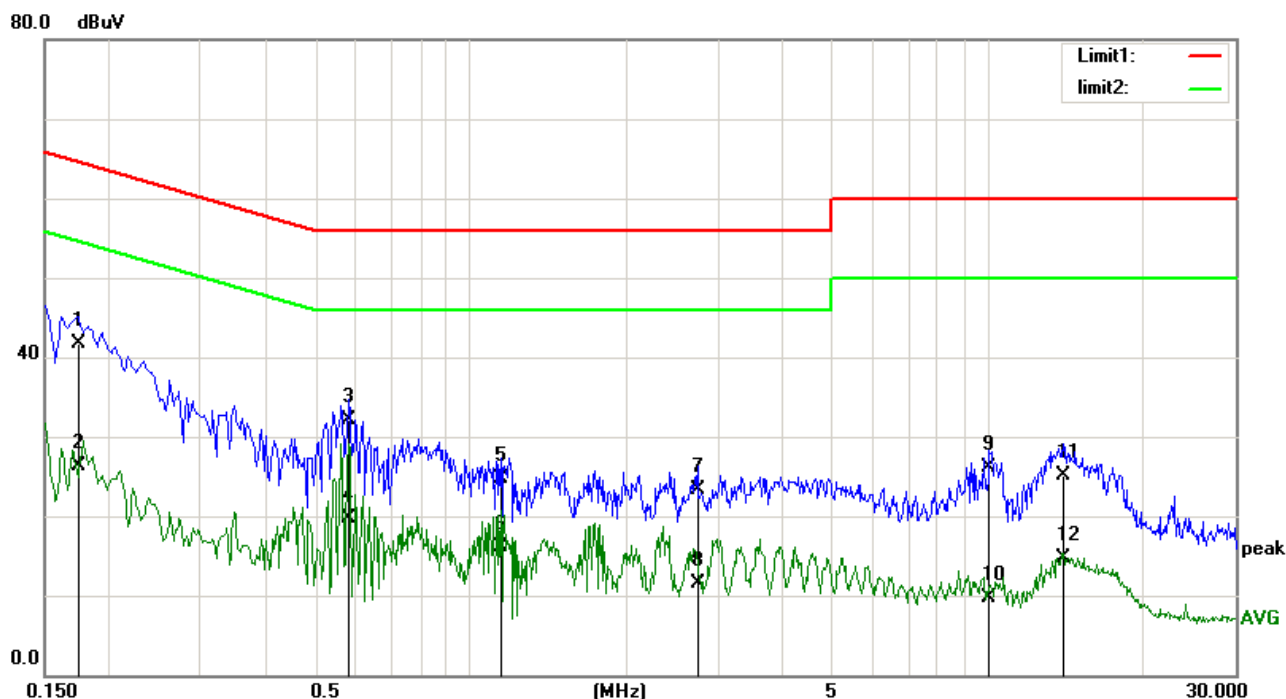

No.	Frequency (MHz)	Reading (dBuV)	Correct Factor(dB)	Result (dBuV)	Limit (dBuV)	Margin (dB)	Remark
1	0.1740	30.34	11.30	41.64	64.76	-23.12	QP
2	0.1740	15.02	11.30	26.32	54.76	-28.44	AVG
3	0.5820	21.87	10.16	32.03	56.00	-23.97	QP
4	0.5820	9.49	10.16	19.65	46.00	-26.35	AVG
5	1.1420	14.52	10.10	24.62	56.00	-31.38	QP
6	1.1420	6.10	10.10	16.20	46.00	-29.80	AVG
7	2.7380	13.14	10.13	23.27	56.00	-32.73	QP
8	2.7380	1.37	10.13	11.50	46.00	-34.50	AVG
9	10.0219	15.96	10.14	26.10	60.00	-33.90	QP
10	10.0219	-0.44	10.14	9.70	50.00	-40.30	AVG
11	13.9179	14.87	10.16	25.03	60.00	-34.97	QP
12	13.9179	4.51	10.16	14.67	50.00	-35.33	AVG

The test result is calculated as the following:

- (1) Result = Reading + Correct Factor
- (2) Correct Factor = (LISN, ISN, PLC or Current Probe) Factor + Cable Loss + Attenuator
- (3) Margin = Result - Limit

10. Antenna Requirements

10.1. Limit

For intentional device, according to FCC 47 CFR Section 15.203, an intentional radiator shall be designed to ensure that no antenna other than that furnished by the responsible party shall be used with the device. And according to FCC 47 CFR Section 15.247 (b), if transmitting antennas of directional gain greater than 6dBi are used, the power shall be reduced by the amount in dB that the directional gain of the antenna exceeds 6dBi.

10.2. Result

Integral antenna with antenna gain 1 dBi