

Honeywell IdentPoint™ Intelligent Smartcard System

INSTALLATION INSTRUCTIONS

GENERAL

IdentPoint™ is an intelligent smart card based access control system that integrates with Enterprise Buildings Integrator™ (EBI) to provide a secure, scalable and a cost effective solution for securing defense installations, airports, and buildings. This document describes how to install and configure the IdentPoint system.

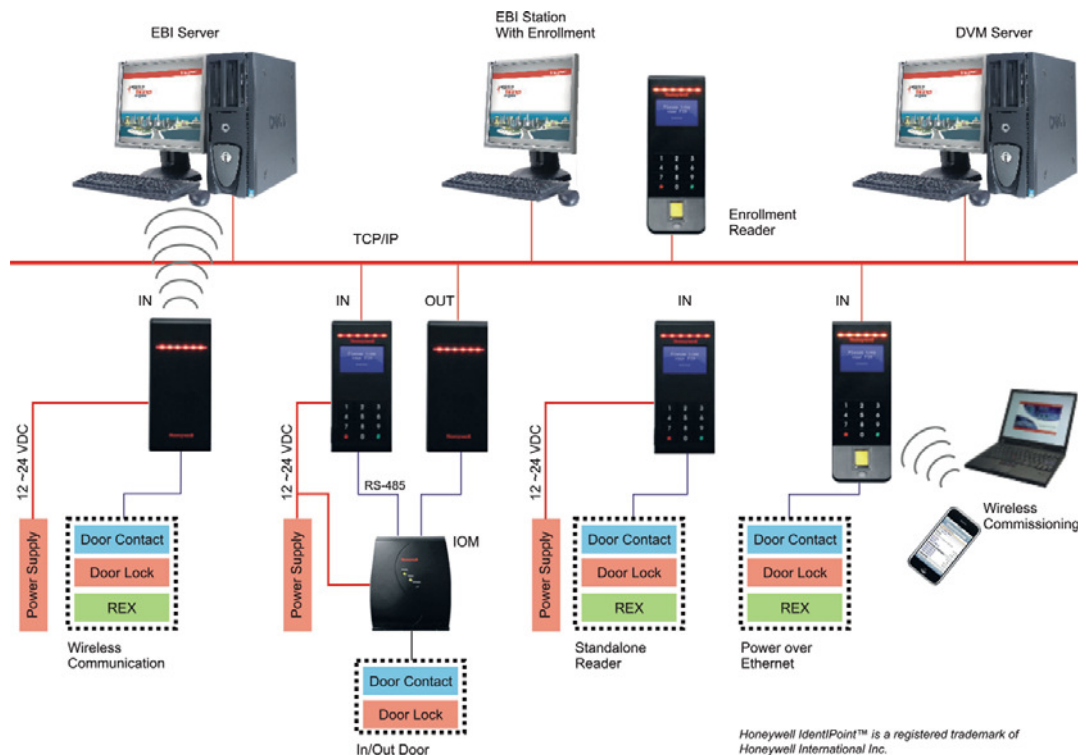

Fig. 1. IdentPoint system architecture



NOTE: For detailed connection diagrams see topics **Detailed Wiring Diagrams and Wiring Other Devices.**

NOTE: Any currently available IdentIPoint reader can be used as an enrollment reader.

OVERVIEW

IdentIPoint is Honeywell's next generation smart card based access control system in conjunction with Honeywell's award winning Enterprise Buildings Integrator - EBITM. IdentIPoint readers come with a powerful built-in controller thus eliminating the need to install a separate multi-door access controller. IdentIPoint offers flexible architecture options including the option of connected and standalone readers. The readers communicate with EBI over a wired or wireless* Ethernet network.

The IdentIPoint hardware family consists of the following models:

- Indoor / Outdoor basic readers - IP65 (BTBAS)
- Indoor readers with LCD & Keypad (BTSTD)
- Indoor readers with LCD, Keypad and Fingerprint (BTFPT)²
- Remote Input Output Module (IOM) (BTIO)

IdentIPoint readers support the following Contactless Smart Card Reader technologies:

- MIFARE Classic 1K, 4K
- MIFARE DESFire 4K
- MIFARE DESFire EV1 4K, 8K

IdentIPoint readers also support the following network technologies:

- Wireless LAN IEEE802.11b/g standard; provides WPA security for infrastructure mode of operation*.
- High speed 10/100 Mbps Ethernet connection for Wired LAN via RJ45.

IdentIPoint readers support the following types of peripheral connections:

- One RS485 serial bus (115200 baud) for IOM
- Bus Termination and BIAS for RS485 on board (jumpers or dip switch)
- Digital Output 1 (current sinking at 1A, 24VDC max.)
- Supervised Inputs 3; capable of distinguishing 4 states
- Relay Contact 1 (1A-24VDC) - Form C
- Two Tamper Inputs:
 - Inner Tamper Switch: Micro-switch (detecting casing opening)
 - Outer Tamper Switch: Optical (detecting unit dismounted from wall)

The readers work with 12V to 24VDC power supply or Power-over-Ethernet (PoE)* conforming to the IEEE 802.3af standard. All software and firmware is remotely upgradeable over the network via EBI.

All the IdentIPoint readers are designed to work with an optional remote IOM. The IOM is used when the control inputs and outputs of the door are desired to be on the secure side of the door - for high security installations. The IOM integrates seamlessly with the readers via a secure encrypted RS485 bus. Up to four IOMs can be connected via the same bus to a reader. The IOMs are independently addressable via DIP switches.

The IOM supports the following types of Inputs and Outputs:

- Relay: 2 - (1A 24VDC) Form C
- Digital Input: 2
- Digital Output: 2 (current sinking; (max 24V 1A)
- Supervised Analog Inputs : 4 ; capable of distinguishing 4 states
- Supervised Analog Output 1 - repeats the last Supervisory Input, SAI3

The IOM works with a 12V to 24VDC power supply. It is possible to control one door using two Readers in IN & OUT mode with the help of an IOM.

* See Table.1.

Models and Part Numbers

The IdentIPoint product-line consists of the following three reader models and one input/output unit:

1. Basic: Basic Indoor / Outdoor reader with IP65 rating³ (Part no.: BTBAS)
2. Standard: Indoor reader with LCD & Keypad (Part no.: BTSTD)
3. Fingerprint: Indoor reader with LCD, Keypad and Fingerprint unit (Part no.: BTFPT)²
4. IOM: Remote Input Output Module (Part no.: BTIO)

NOTE:

1. For device ratings, see product datasheet (Document no. 74-5086).
2. The BTFPT module is not UL294 listed and shall not be used for UL applications.
3. IP65 enclosure rating was not evaluated by UL.

BEFORE INSTALLATION

1. Verify the mounting locations with the job drawings.
2. Unpack the IdentIPoint reader, IOM and accessories and check them. Report any damaged or missing components to a Honeywell representative. A claim must be filed with the commercial carrier responsible.



WARNING

Fire Safety and Liability Notice: Never connect card readers to any critical entry, exit door, barrier, elevator or gate without providing an alternative exit in accordance with all fire and life safety codes pertinent to the installation. These fire and safety codes vary from city to city and you must get approval from local fire officials whenever using an electronic product to control a door or other barrier. Use of egress buttons, for example, may be illegal in some cities. In most applications, single action exit without prior knowledge of what to do is a life safety requirement. Always make certain that any required approvals are obtained in writing. Verbal approvals are not valid.

IMPORTANT

Table 1.

1	For UL294 applications, only UL294 and/or UL1076 listed power supplies should be used for reader and lock power with required 72 hour battery backup.
2	Use of PoE is not a UL294 listed configuration and should not be used on UL294 applications.
3	Wifi network configuration is not a UL294 listed configuration and should not be used on UL294 applications.
4	As a standalone or disconnected reader is not supervised, this configuration should not be used on UL294 applications.
5	For UL294 applications using an IOM, note that the IOM needs to be kept on the secure side of the door i.e. indoors, and within a distance of 7.5 meters from the reader to which it is connected. In case the distance between the IOM and the reader exceeds 7.5 meters, the use of lightning protection devices on the RS485 line is mandatory.
6	The class of these products is a UL294 Access Control System, complying with UL294 Attack Class I.

IDENTIPOINT HARDWARE

Inside the reader box

- Intelligent Reader Unit - 1
- Mounting Plate - 1
- Mounting Hardware - Screws and Wall Anchors - 6 each
- Extra Tamper Resistant Screws - 2
- Tool for Tamper Resistant Screw - 1
- Connector with cable - 2 (9 and 10 pin)
- Resistors - 2K (Color Code: RED-BLACK-RED-GOLD; 0.5W axial type, 5% tolerance) - 3
- Resistors - 1K (Color Code: BROWN-BLACK-RED-GOLD; 0.5W axial type, 5% tolerance) - 3
- Square ferrite clip - 1
- Round ferrite clip - 1
- Quick Installation Guide - 1

Inside the IOM box

- Input / Output Module Unit - 1
- Mounting Hardware - Screws and Wall Anchors - 3 each

- Extra Tamper Resistant Screws - 2
- Tool for Tamper Resistant Screw - 1
- Connectors for termination - 12 x 2 connections; 3 x 3 connections
- Resistors - 2K (Color Code: RED-BLACK-RED-GOLD; 0.5W axial type, 5% tolerance) - 4
- Resistors - 1K (Color Code: BROWN-BLACK-RED-GOLD; 0.5W axial type, 5% tolerance) - 6
- Quick Installation Guide - 1

ASSEMBLY, MOUNTING AND INSTALLATION

Mounting and Installing the Reader

NOTE:

- The reader can be mounted either on a drywall or on a concrete wall using conduits and a gang box.

- The drywall and gang boxes shown here are just representations of the actual hardware. During installation, please use the hardware as per the required dimensions and availability.
- To install IdentIPoint devices in place of older devices that have been removed, you may use the TRADELINE® 209651A Universal Cover Plate to cover marks from the older devices and allow mounting of IdentIPoint devices on vertical or horizontal outlet boxes. See document no. 69-1093 for more details.

WARNING

Earth ground all enclosures for proper installation. It is mandatory to connect the "Frame Ground" on the J10 terminal of the fingerprint reader to an electronic earth. In case an electronic earth is not available then "Frame Ground" can be connected to the Input Power Supply earth or common ground available nearby.

WARNING

Make all electrical field connections to reader and IOM(s) before applying DC power to configuration. Failure to do so and connecting positive terminal first on IOM before negative can result in failed operation that would require power recycling. Do not make power connections with power applied to wiring/terminal blocks - power down all circuits before connecting or disconnecting all terminal blocks on reader or IOM.

Drywall Mounting

1. Fig.2 and Fig.3 show the parts of the IdentIPoint reader. Use the back-plate of the reader to mark out the position of the reader on the drywall. Mark the positions of the mounting screws and the opening for routing the cables.
2. Cut the cable opening on the drywall using suitable tools and punch an adequate number of holes for the mounting screws. It is advisable to use at least four screws to mount the reader. Use the wall anchors for additional holding strength. See Fig.4.
3. Hold the back-plate in position on the drywall. Align the mounting screws with their holes and fasten the back-plate securely on the drywall using the screws. See Fig.4.
4. Route the field wires including the Ethernet cable (if required) from behind the drywall through the cable opening and bring them to the front of the mounting surface. See Fig.6. Clip the square* ferrite clip on the reader's Ethernet pigtail. See Fig.7. Connect the field wiring to the correct Molex pigtails. See Table.2 for wire sizes and distances. For reader connection details see Fig.11 and Table.5 and Table.6. Plug the Molex terminal(s) in ports J9 and J10 at the back of the reader. See Fig.7. Clip (with two turns wrapped) the round** ferrite clip on the field Ethernet cable. See Fig.6. Plug the RJ45 connector of the field Ethernet cable into the Ethernet port of the reader at the end of the pigtail. See Fig.7. Drop the excess lengths of Molex and Ethernet wires behind the drywall. Set the S1 DIP switch if the reader is to be connected to an IOM via RS485. See

Fig.11, Table.7 and Section *RS485 Communication and Termination Setting of Connector and Switch Descriptions* topic for more details.

5. Once all the connections and settings are done, hold the reader against the back-plate, aligning the mounting slots at the back of the reader with their corresponding catches on the back-plate and push it downwards until it hooks into place firmly. See Fig.8 and Fig.9.
6. Use the Allen wrench to tighten the tamper-resistant screw at the bottom of the reader into the hole provided on the back-plate so as to fasten the reader to the back-plate securely. See Fig.10.

* Required for the unit to limit emissions within FCC part 15 Class B level. Should be clipped on the reader's Ethernet pigtail and accommodated behind the drywall.

** Required for the unit to limit emissions within FCC part 15 Class B level. Can be clipped either near the reader or at the far end (near the network switch) of the field Ethernet cable.

Gang Box (concrete wall) Mounting

1. Fig.2 and Fig.3 show the parts of the IdentIPoint reader. Ensure that the correct sized gang box is securely embedded in the concrete wall. The holes provided in the gang box for the screws should align properly with at least two of the holes provided in the reader back-plate for the screws.
2. Hold the back-plate in position over the gang box. Align the mounting screws with their holes and fasten the back-plate securely on the gang box using the screws. See Fig.5.
3. Route the field wiring including the Ethernet cable (if required) from the conduits into the gang box. Clip the square* ferrite clip on the reader's Ethernet pigtail. See Fig.7. Connect the field wiring to the correct Molex pigtails. See Table.2 for wire sizes and distances. For reader connection details see Fig.11 and Table.5 and Table.6. Route the Molex terminal(s) through the cable opening on the back-plate towards the front of the mounting surface (see Fig.6) and plug them in ports J9 and J10 at the back of the reader. See Fig.7. Clip (with two turns wrapped) the round** ferrite clip on the field Ethernet cable. See Fig.6. Plug the RJ45 connector of the field Ethernet cable into the Ethernet port of the reader provided at the end of the pigtail. See Fig.7. Allow room for the Molex and Ethernet pigtails inside the gang box. Set the S1 DIP switch if the reader is to be connected to an IOM via RS485. See Fig.11, Table.7 and Section *RS485 Communication and Termination Setting of Connector and Switch Descriptions* topic for more details.
4. Once all the connections and settings are done, hold the reader against the back-plate, aligning the mounting slots at the back of the reader with their corresponding catches on the back-plate and push it downwards until it hooks into place firmly. See Fig.8 and Fig.9.
5. Use the Allen wrench to tighten the tamper-resistant screw at the bottom of the reader into the hole provided on the back-plate so as to fasten the reader to the back-plate securely. See Fig.10.

* Required for the unit to limit emissions within FCC part 15 Class B level. Should be clipped on the reader's Ethernet pigtail and accommodated inside the gang box.

** Required for the unit to limit emissions within FCC part 15 Class B level. Can be clipped either near the reader or at the far end (near the network switch) of the field Ethernet cable.

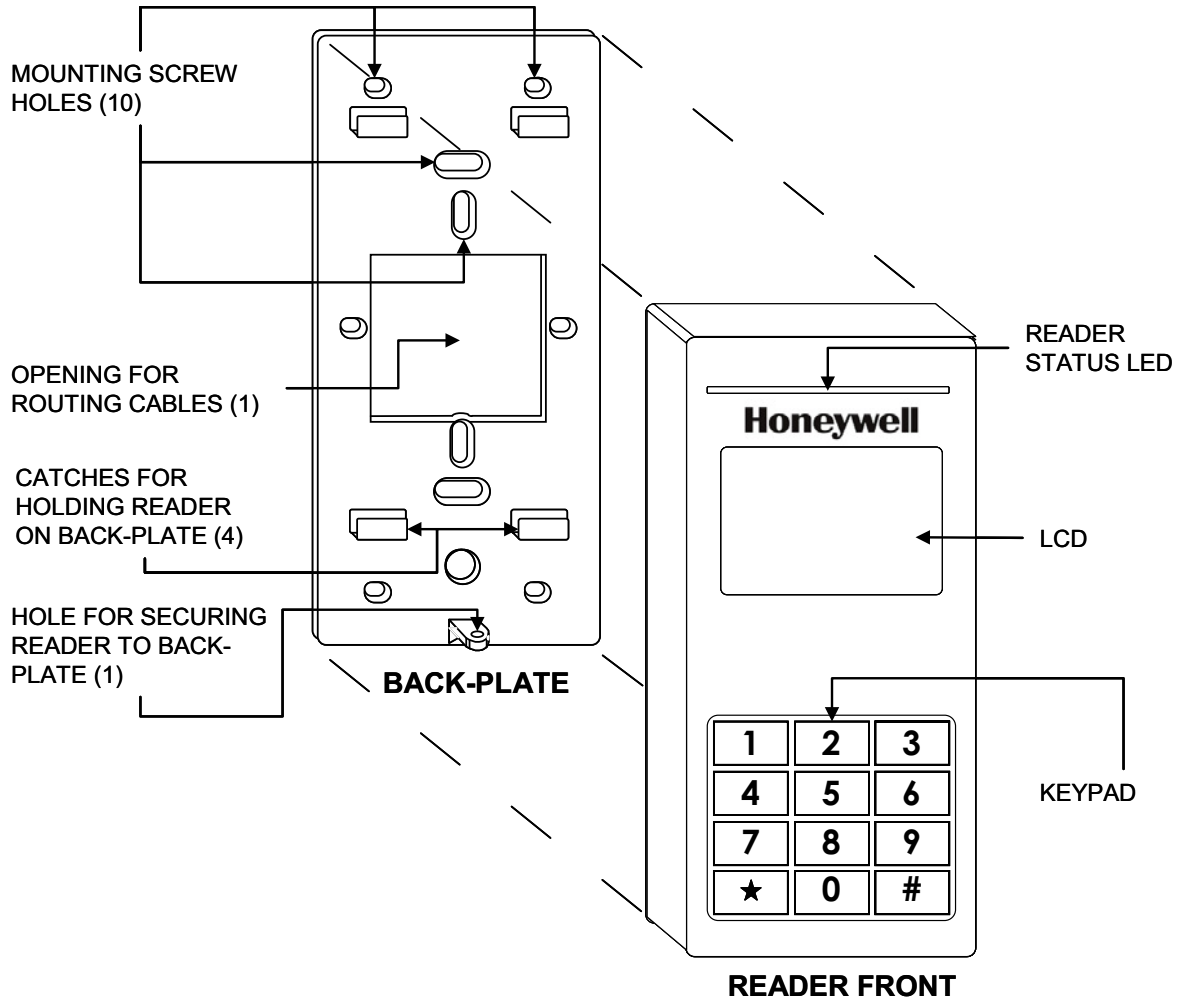

Fig. 2. Parts of IdentIPoint reader - Front of reader and Back-plate

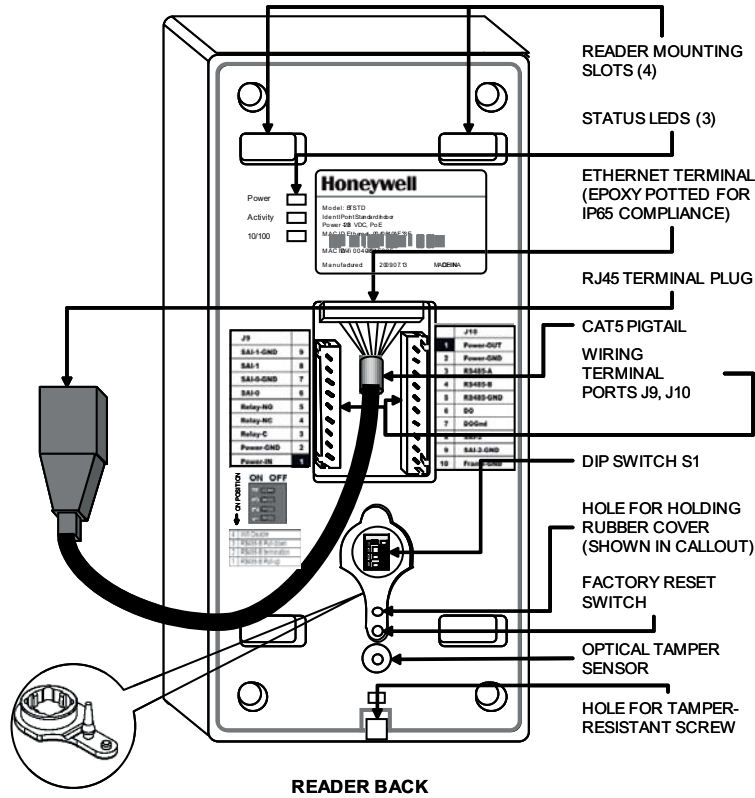

Fig. 3. Parts of Identipoint reader - Back of reader

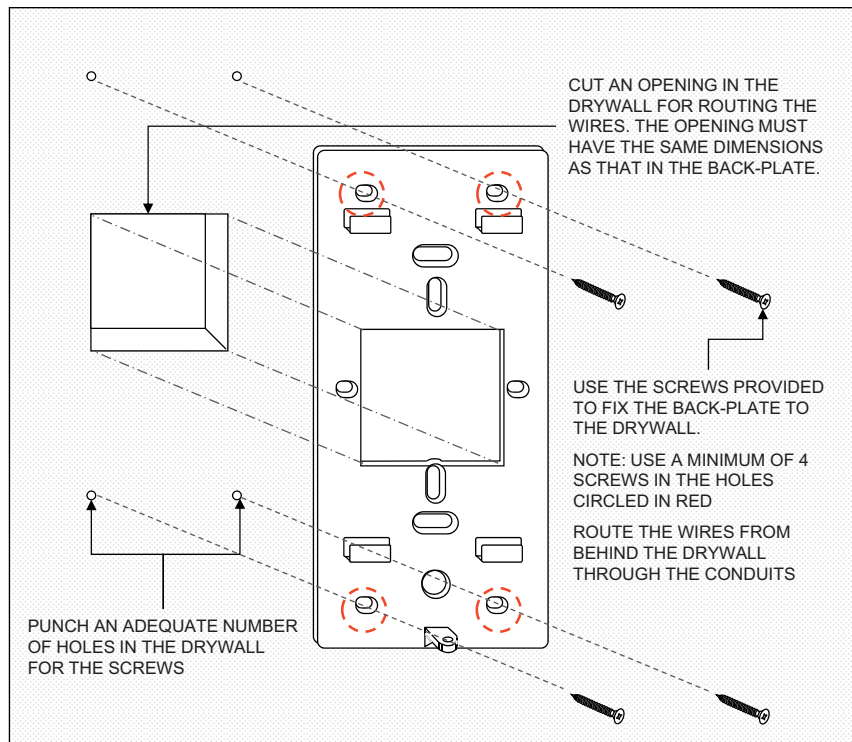

Fig. 4. Mounting reader back-plate on drywall

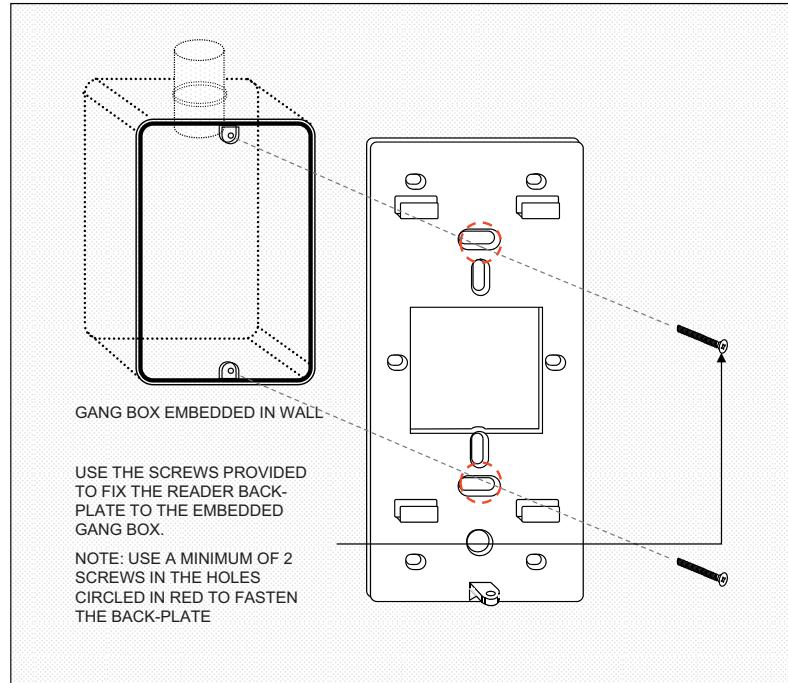

Fig. 5. Mounting reader back-plate on concrete wall using gang box and conduit

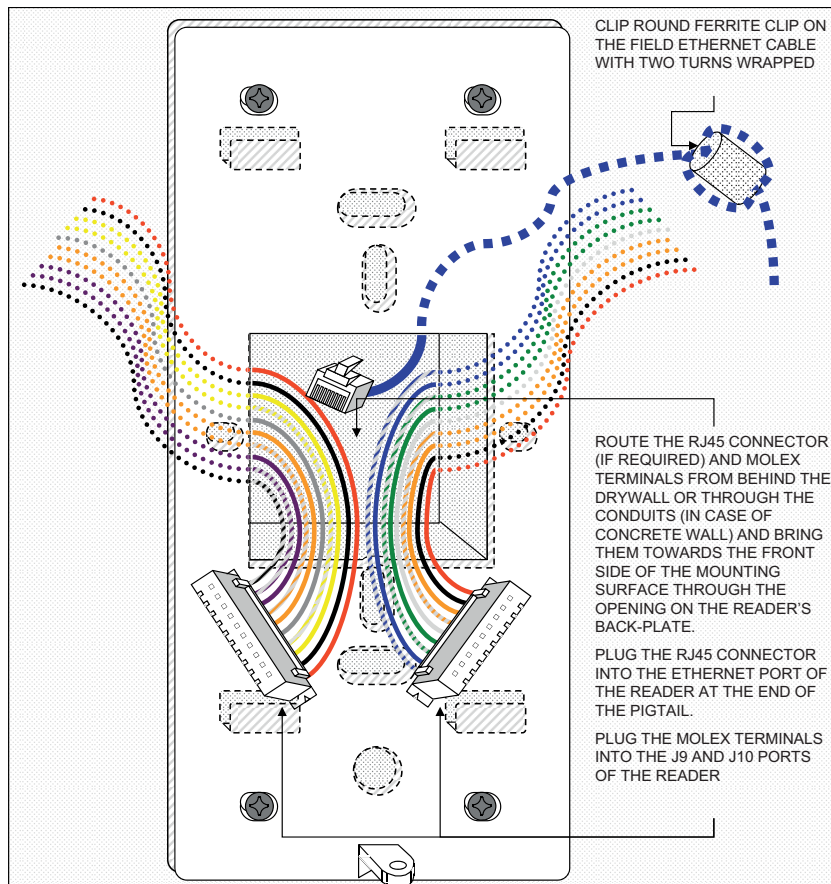

Fig. 6. Routing the wires before plugging the connectors into the reader

NOTE: Round ferrite clip is required for the unit to limit emissions within FCC part 15 Class B level. Can be clipped either near the reader or at the far end (near the network switch) of the field Ethernet cable. The connector wire colors shown above are only indicative. Refer to Table.5 and Table.6 for the correct colors.

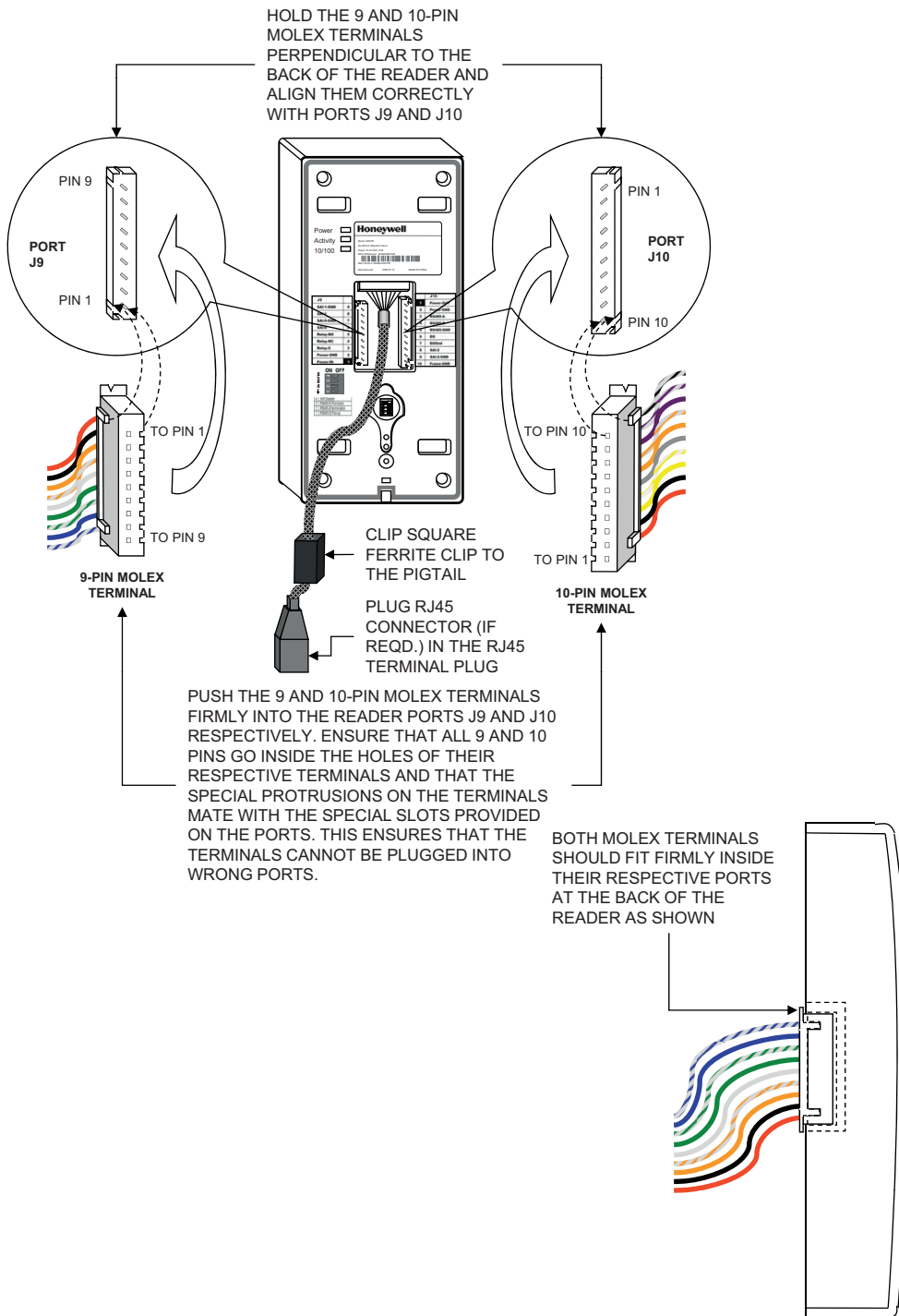

Fig. 7. Plugging the connectors into the IdentIPoint reader

NOTE: Square ferrite clip is required for the unit to limit emissions within FCC part 15 Class B level. Should be clipped on the reader's Ethernet pigtail and accommodated behind the drywall or inside the gang box. The connector wire colors shown above are only indicative. Refer to Table.5 and Table.6 for the correct colors.

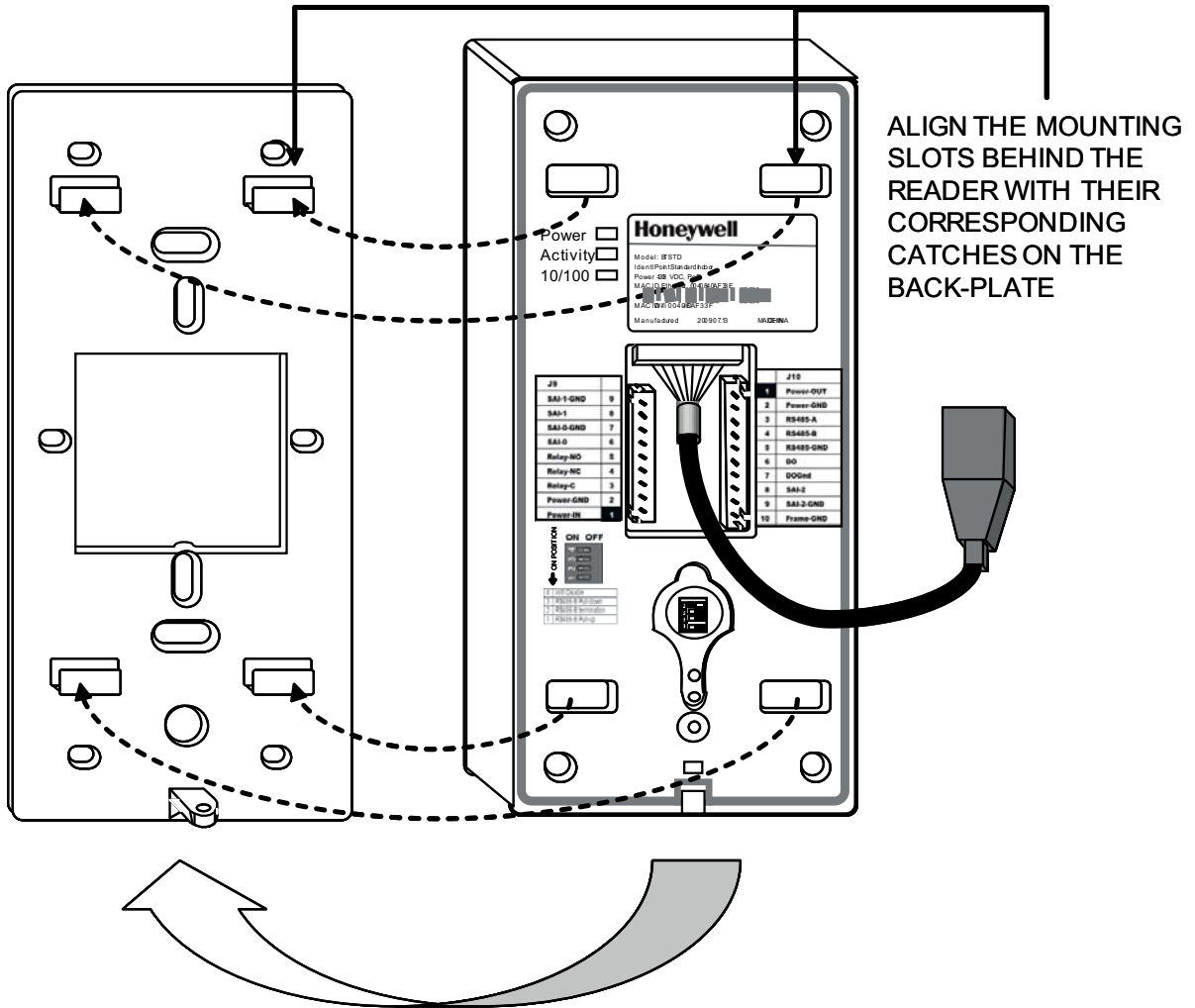

Fig. 8. Aligning IdentIPoint reader with back-plate before mounting it

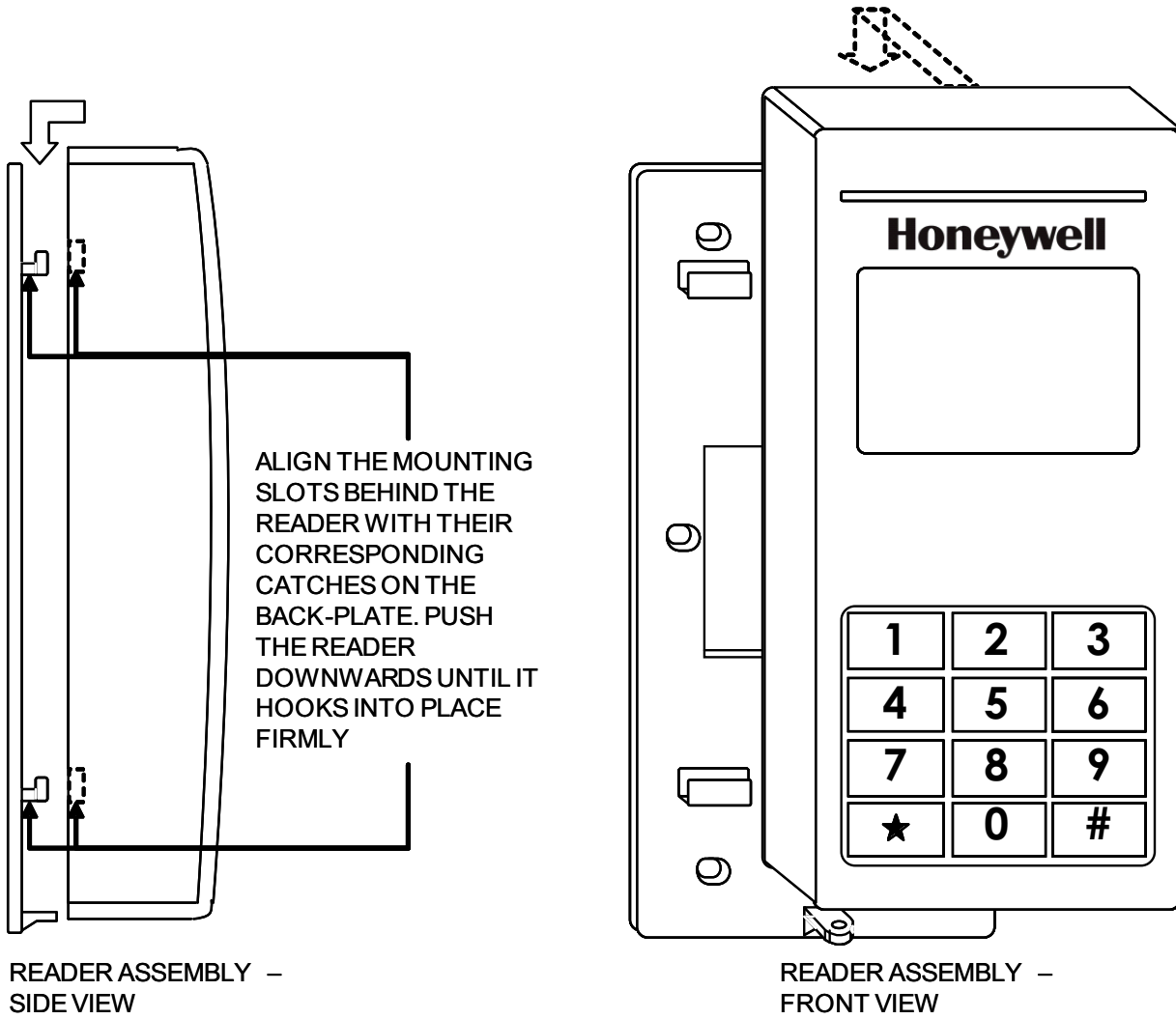

Fig. 9. Mounting IdentIPoint reader on the back-plate

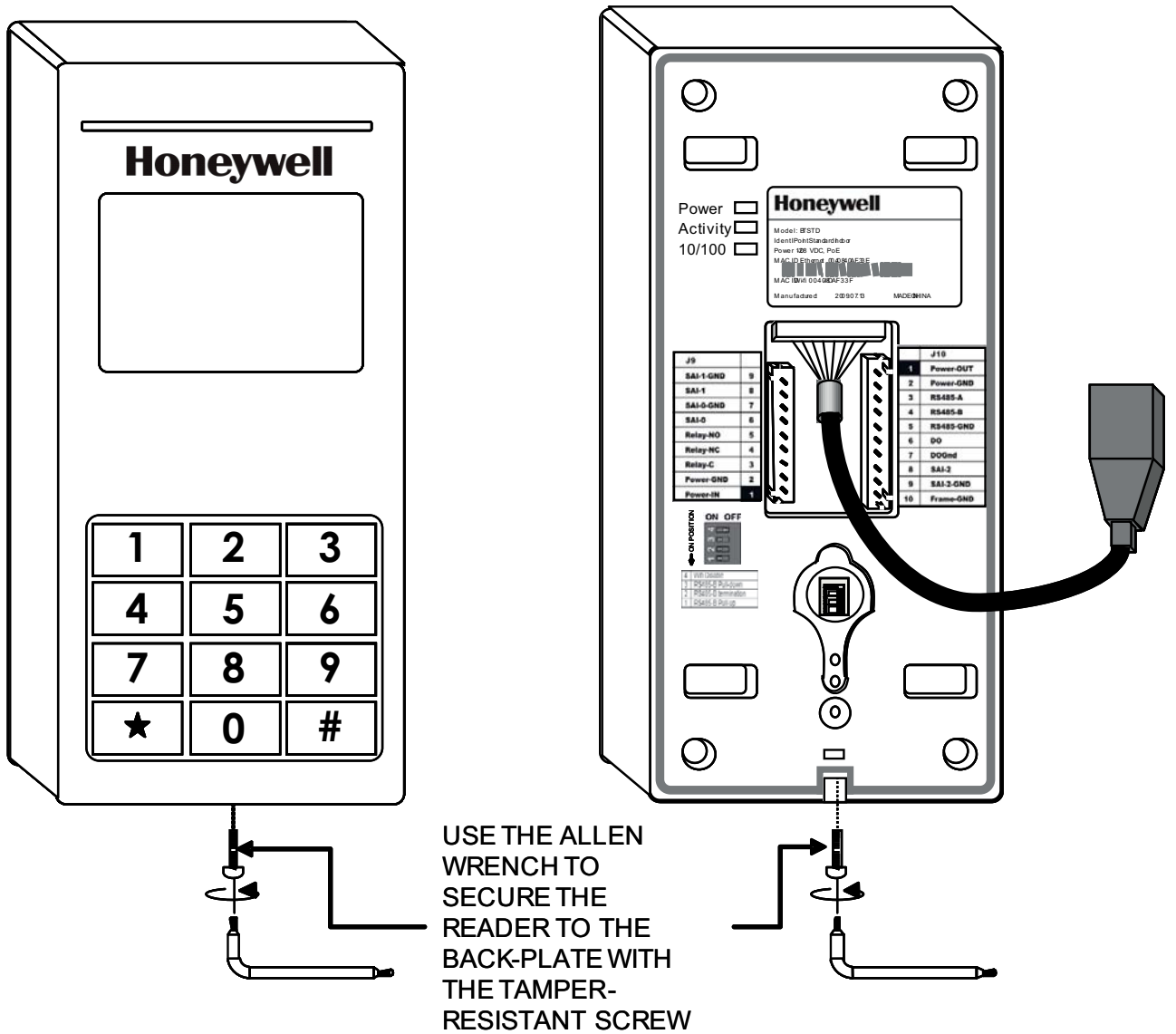

Fig. 10. Securing the IdentIPoint reader to the back-plate

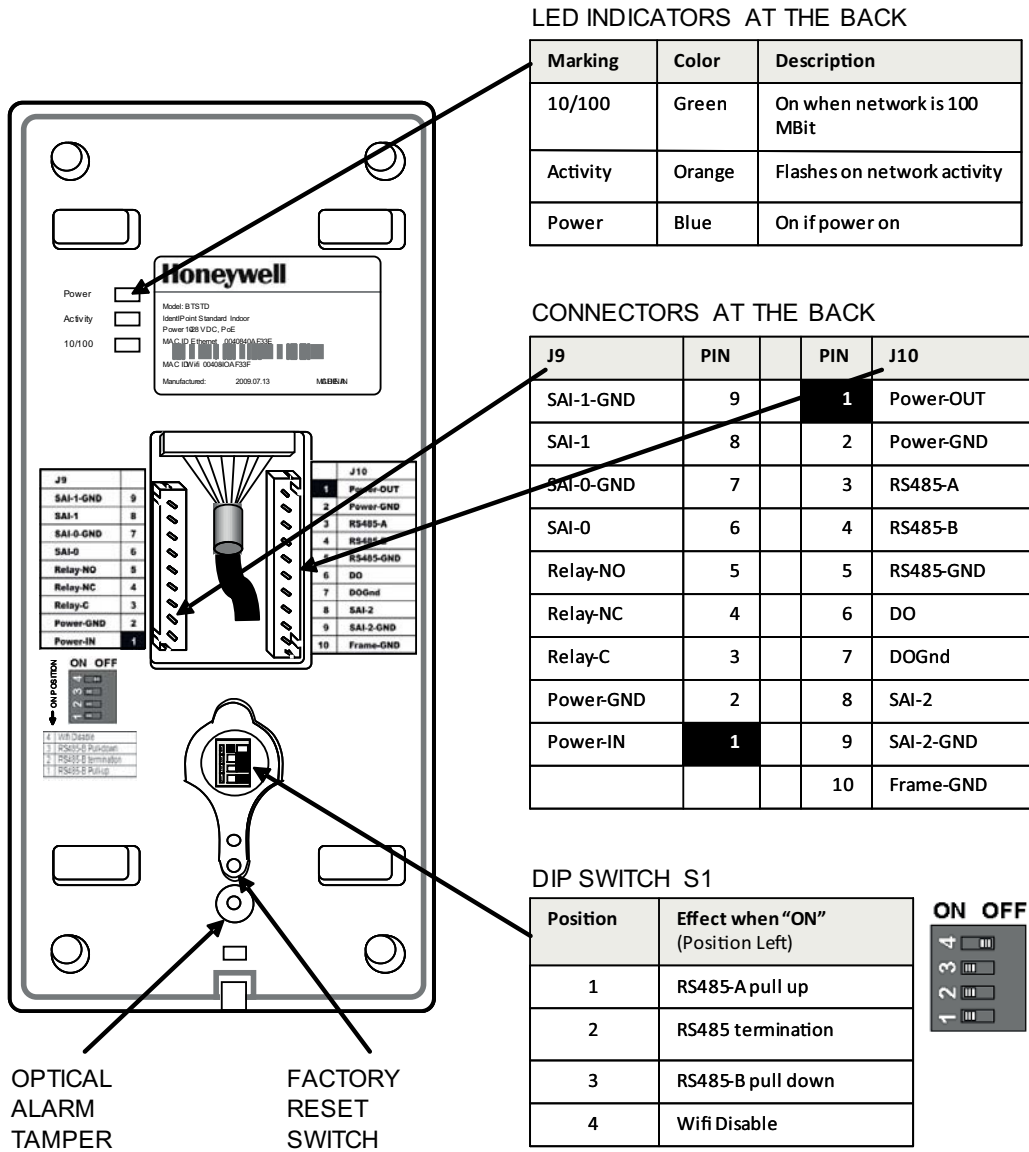

Fig. 11. Reader connections

Mounting and Installing the Input/Output Module

NOTE:

- The IOM can be mounted either on a drywall or on a concrete wall using conduits and a gang box.
- The drywall and gang boxes shown here are just representations of the actual hardware. During installation, please use the hardware as per the required dimensions and availability.
- To install IdentIPoint devices in place of older devices that have been removed, you may use the TRADELINE® 209651A Universal Cover Plate to cover marks from the older devices and allow mounting of IdentIPoint devices on vertical or horizontal outlet boxes. See document no. 69-1093 for more details.



WARNING

Make all electrical field connections to reader and IOM(s) before applying DC power to configuration. Failure to do so and connecting positive terminal first on IOM before negative can result in failed operation that would require power recycling. Do not make power connections with power applied to wiring/terminal blocks - power down all circuits before connecting or disconnecting all terminal blocks on reader or IOM.



WARNING

Grounds need to be affixed first before applying any power to a configuration. The dedicated ground connector J3 on the IOM (see Fig.18) can be used for the above purpose.



WARNING

No components should be added to a hot i.e. powered up configuration.



CAUTION

Electro-static discharge (ESD) can damage CMOS integrated circuits and modules. To prevent damage always follow these procedures:

- Use static shield packaging and containers to transport all electronic components, including completed reader assemblies.
- Handle all ESD sensitive components at an approved static controlled workstation.

Drywall Mounting

1. The IOM has a clamshell plastic case. The back half of the case has the electronic circuit board fastened to it while the front case cover swings open to allow access to the electronics and wiring. Pull open the front cover. This reveals the mounting holes and other components inside the IOM. See Fig.12 and Fig.13.
2. Use the back half to mark out the position of the IOM on the drywall. Also mark the positions of the mounting screws and the openings for routing the cables. See Fig.14.
3. Cut the two cable openings on the drywall using suitable tools. The openings should be aligned with the knock-out holes provided on the back half for routing the cables. Also punch three holes at suitable places in the drywall for the mounting screws. Use the wall anchors for additional holding strength. See Fig.14.
4. Ensure that the knock-out holes on the back half have been opened up. (Knock-out holes are also provided on both sides of the IOM enclosure in case field conditions require routing the wires from the sides.) Hold the back half in position on the drywall. Align the mounting screws with their holes and fasten the back half securely on the drywall using the three screws. See Fig.14.
5. Route the field wires from behind the drywall through the cable opening and bring them inside the IOM via the knock-out holes. See Table.2 for wire sizes and dis-

tances. Connect the wire terminals to the ends of the wires and plug the wire terminal(s) in their correct slots on the PCB. See Fig.16. For IOM connection details see Fig.18 and Table.8. Drop the excess wire lengths behind the drywall. Set the S1 DIP switch if the IOM is to be connected to a reader via RS485. See Fig.18, Table.10 and Section *RS485 Communication and Termination Setting of Connector and Switch Descriptions* topic for more details.

6. Set the IOM address as per Fig.18, Table.11 and Section *IOM Address Setup of Connector and Switch Descriptions* topic for more details.
7. Once all connections and settings are done, close the IOM enclosure by pressing the front case cover over the back half. See Fig.16.
8. Use the Allen wrench to tighten the tamper-resistant screw at the top of the IOM enclosure. See Fig.17.

Gang Box (concrete wall) Mounting

1. The IOM has a clamshell plastic case. The back half of the case has the electronic circuit board fastened to it while the front case cover swings open to allow access to the electronics and wiring. Pull open the front cover. This reveals the mounting holes and other components inside the IOM. See Fig.12 and Fig.13.
2. Ensure that the correct sized gang box is securely embedded in the concrete wall. One of the holes provided in the gang box for the screws should align properly with at least the top hole provided in the IOM's back half for the screw. For the remaining screws punch additional holes at the correct places directly in the concrete wall. Use the wall anchors for additional holding strength. The gang box itself should be large enough to cover both the knock-out cable holes at the back of the IOM. See Fig.15.
3. Route the field wires from the conduits into the gang box and bring them inside the IOM via the knock-out holes. See Table.2 for wire sizes and distances. The IOM can now be mounted on the wall. Hold the back half in position over the gang box and wall. Align the three mounting screws with their holes and fasten the back half securely on the gang box and wall using the screws. See Fig.15.
4. Connect the wire terminals to the ends of the wires and plug the wire terminal(s) in their correct slots on the PCB. See Fig.16. For IOM connection details see Fig.18 and Table.8. Allow room for any excess wire lengths inside the gang box. Set the S1 DIP switch if the IOM is to be connected to a reader via RS485. See Fig.18, Table.10 and Section *RS485 Communication and Termination Setting of Connector and Switch Descriptions* topic for more details.
5. Set the IOM address as per Fig.18, Table.11 and Section *IOM Address Setup of Connector and Switch Descriptions* topic for more details.
6. Once all connections and settings are done, close the IOM enclosure by pressing the front case cover over the back half. See Fig.16.
7. Use the Allen wrench to tighten the tamper-resistant screw at the top of the IOM enclosure. See Fig.17.

NOTE: The power supply wiring for the BTIO IOM shall be enclosed by conduit.

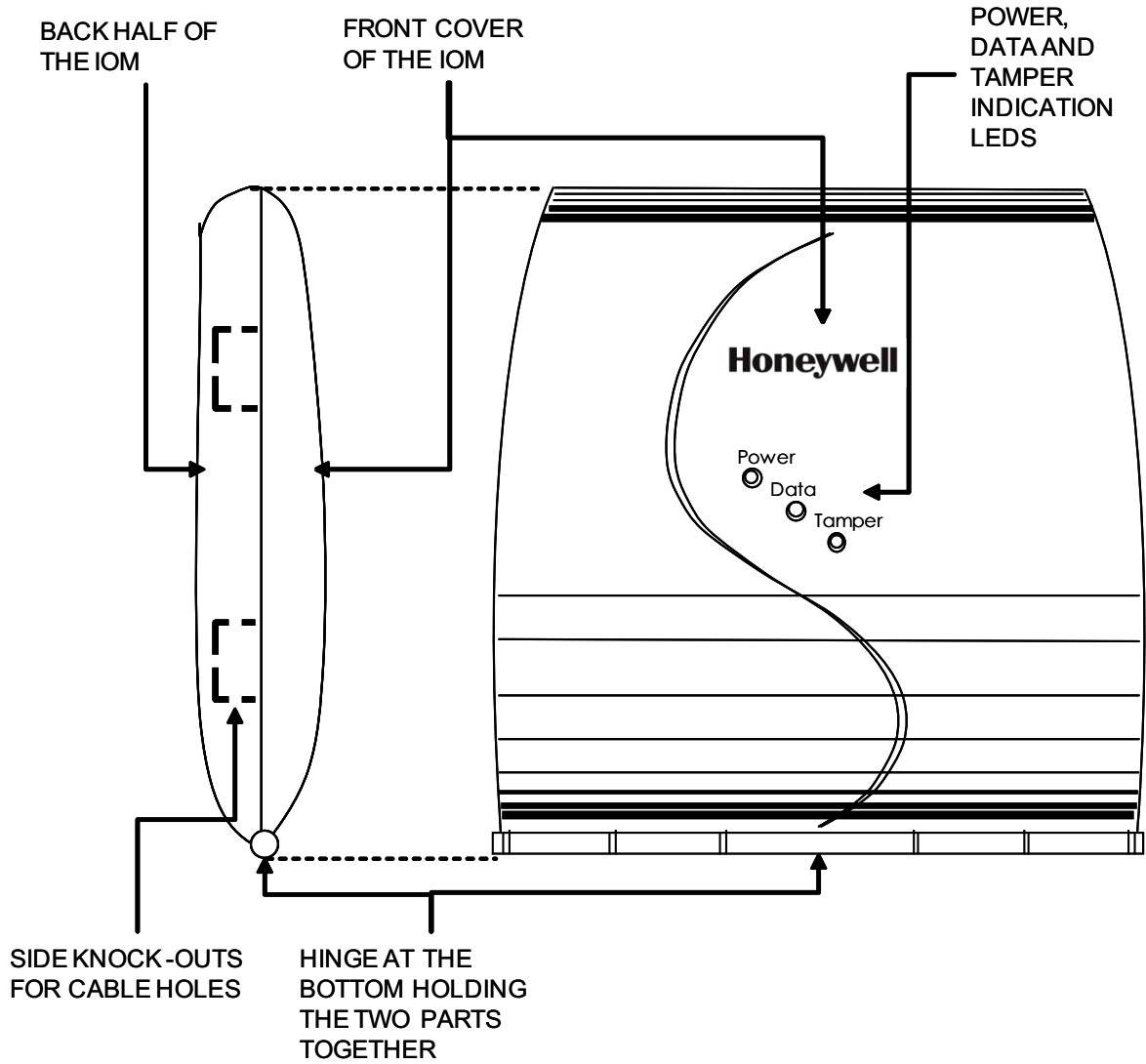

Fig. 12. Outer structure of IOM - Front and side view

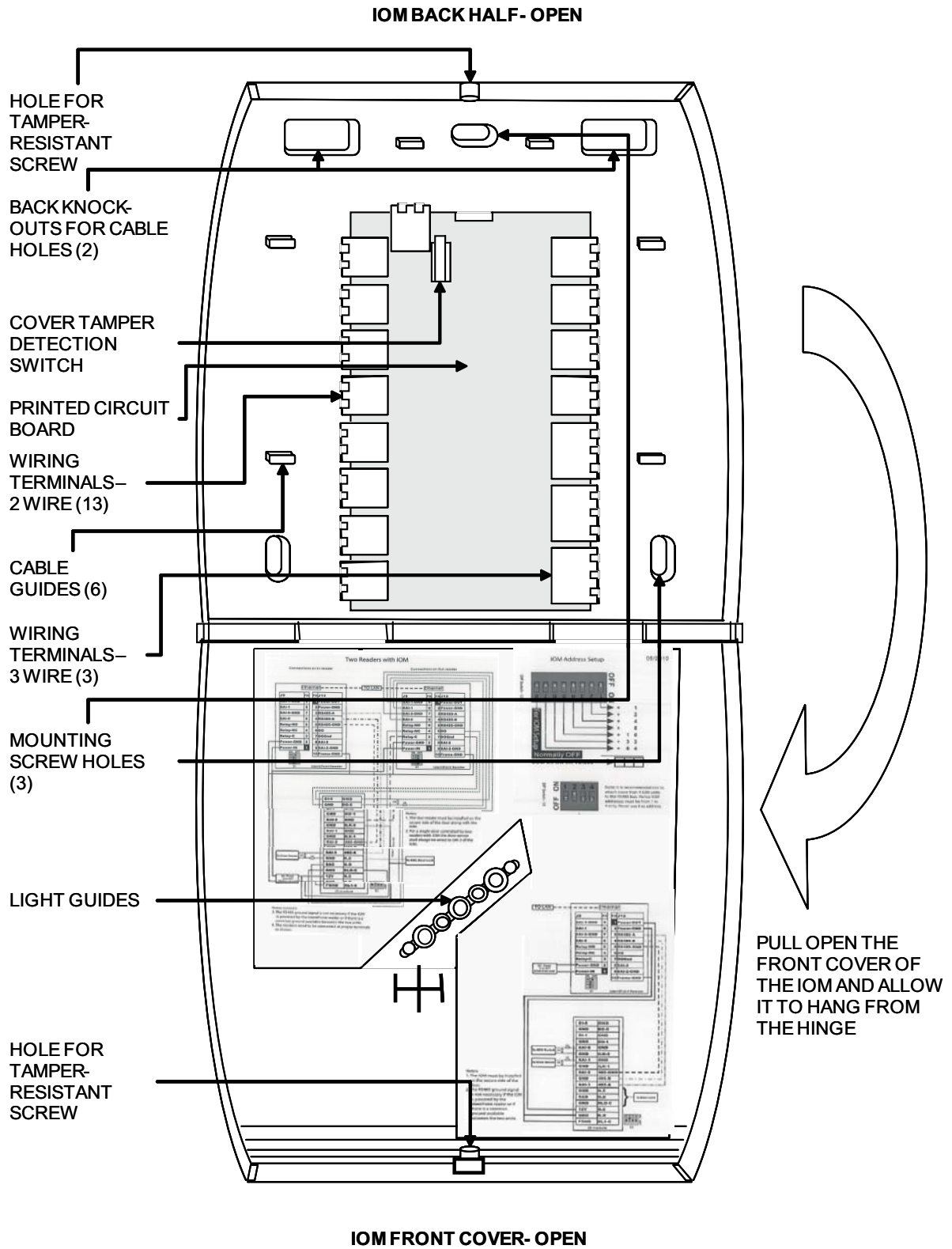

Fig. 13. Internal structure and components of IOM

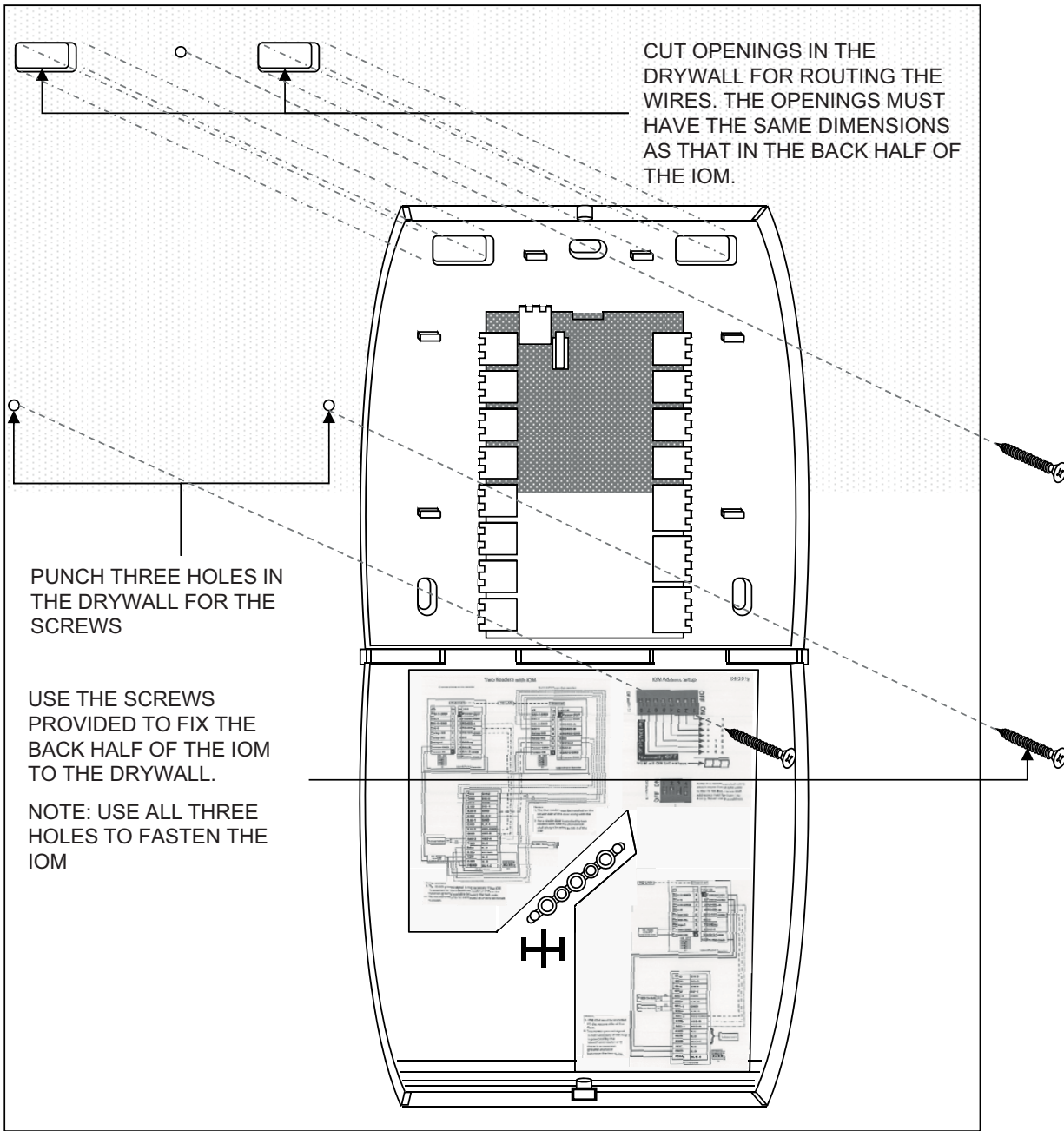

Fig. 14. Mounting the IOM on a drywall

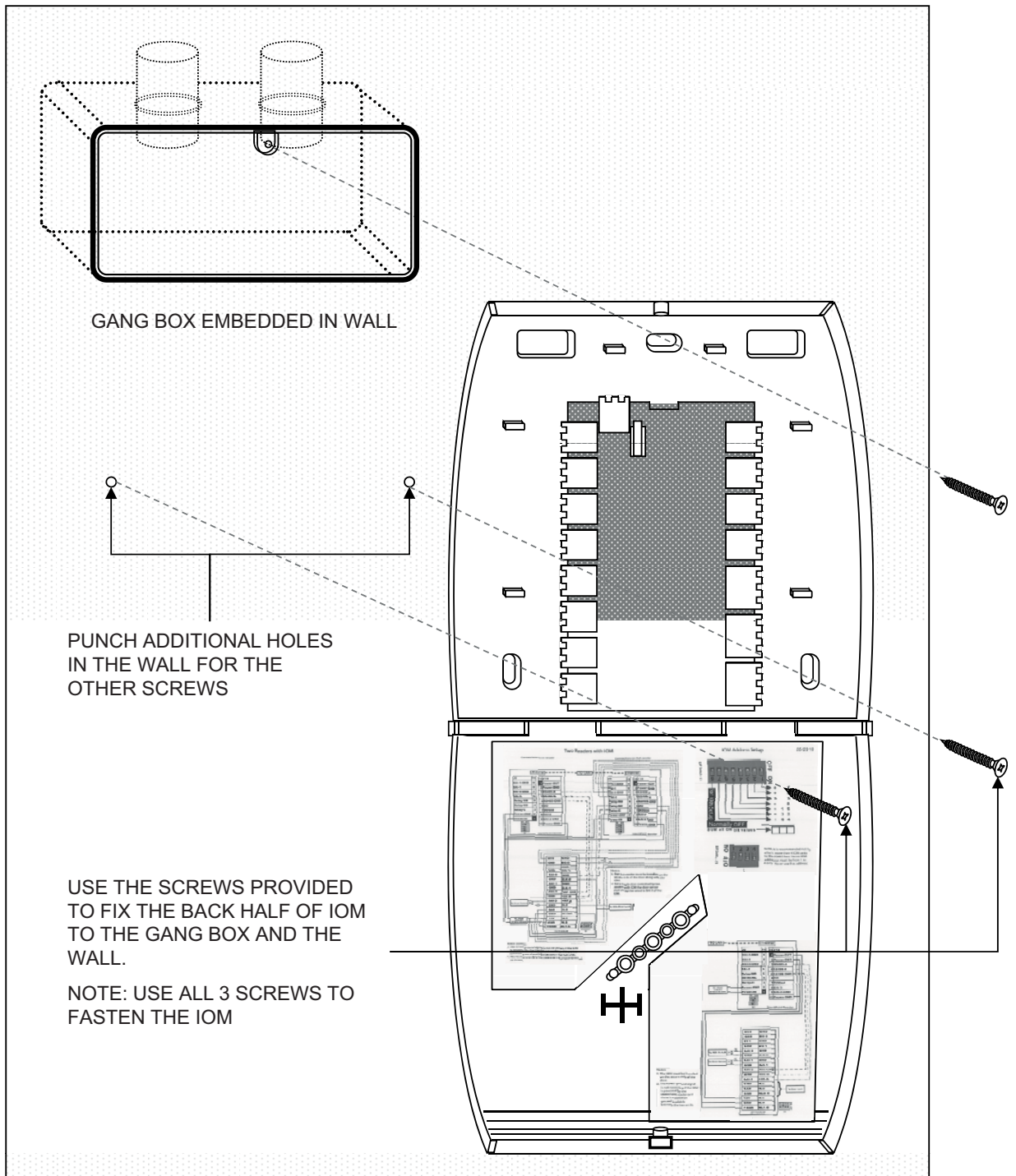

Fig. 15. Mounting the IOM on a concrete wall using gang box and conduit

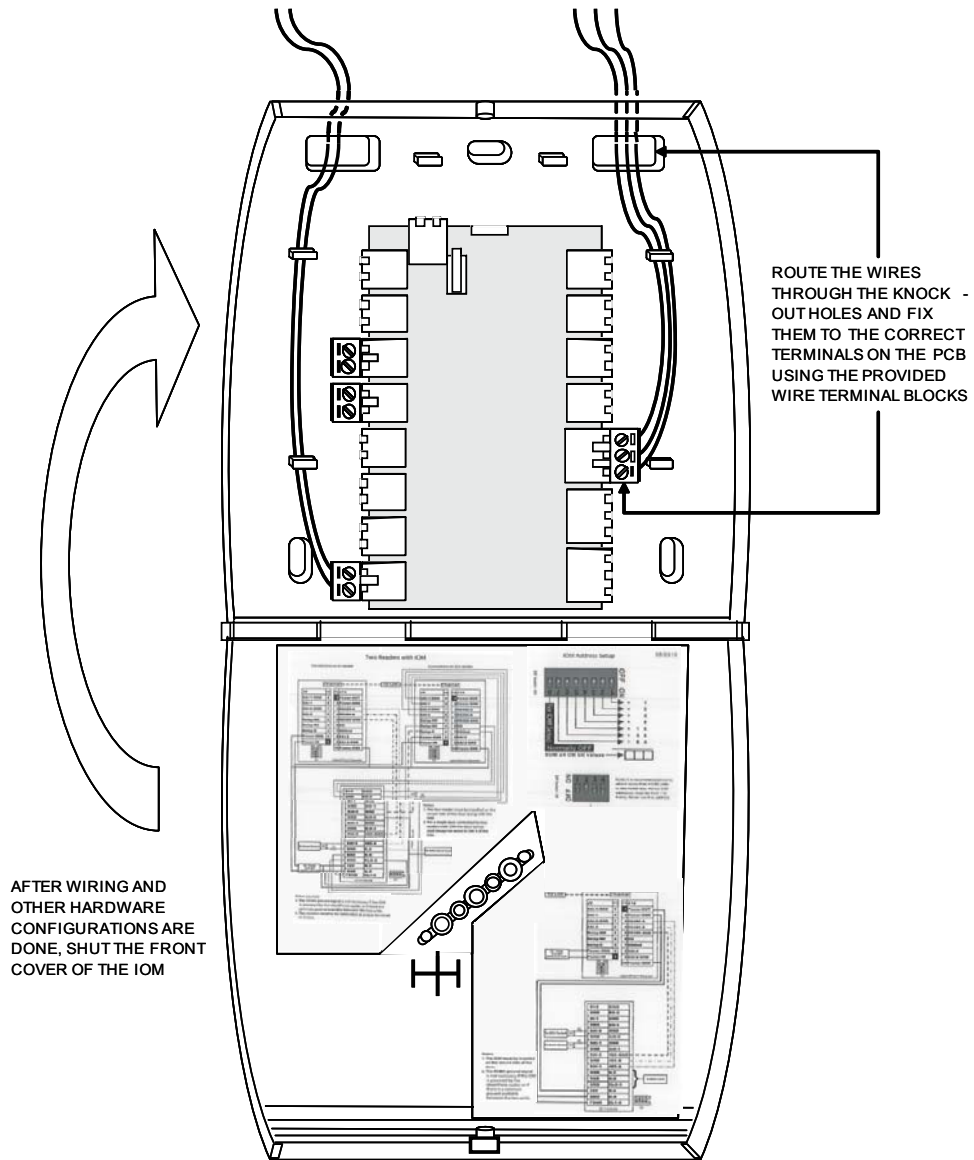

Fig. 16. Routing the wires and connecting them to the IOM PCB

USE THE ALLEN
WRENCH TO
SECURE THE FRONT
COVER OF THE IOM
TO THE BACK HALF
WITH TAMPER-
RESISTANT SCREW

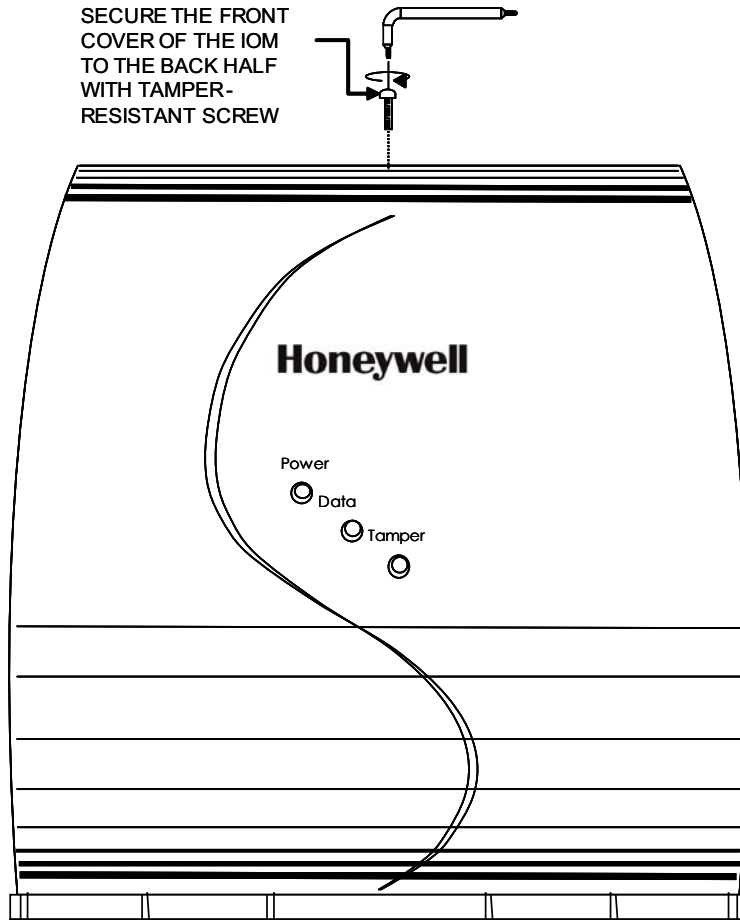

Fig. 17. Securing the front cover onto the back half of the IOM

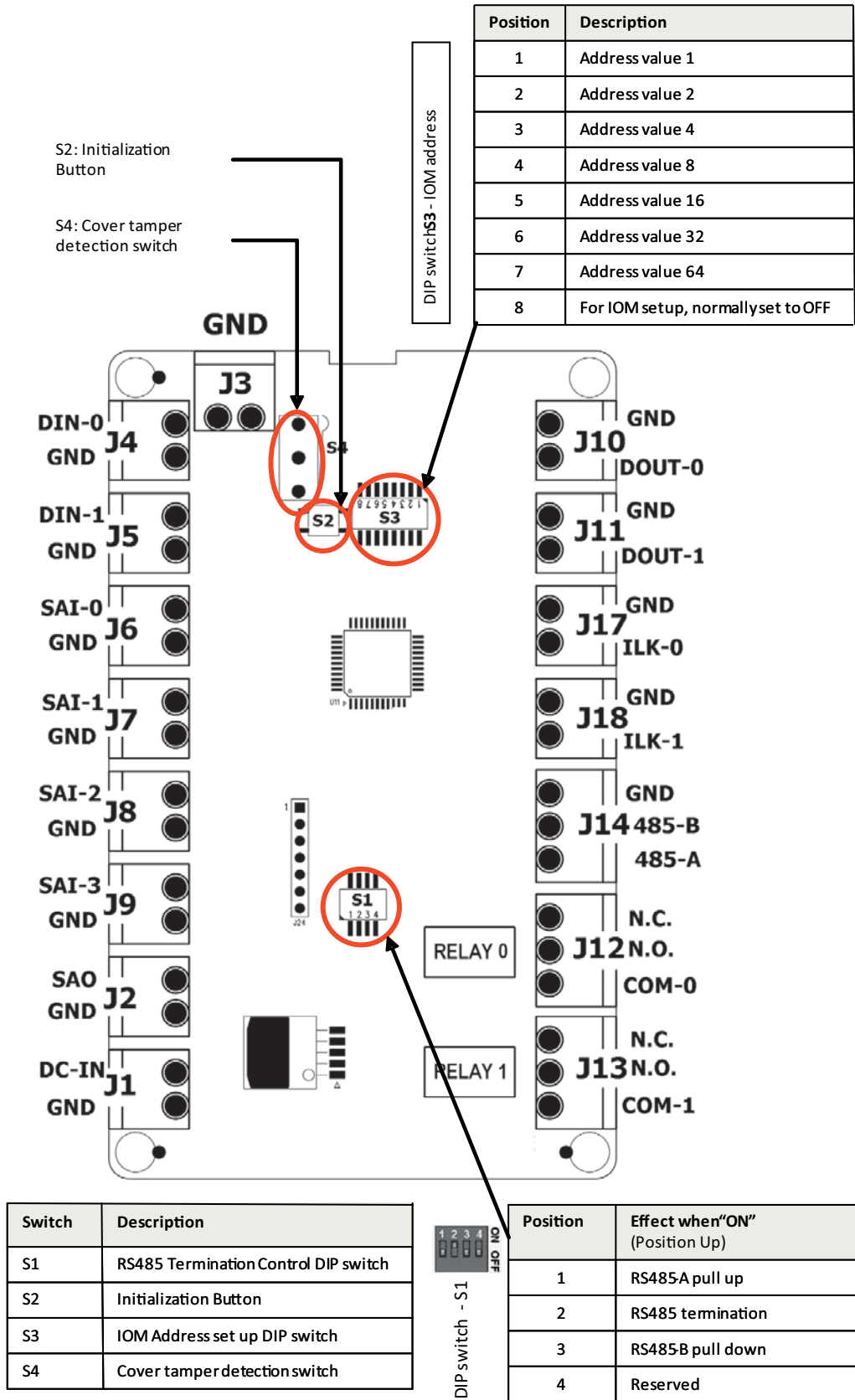

Fig. 18. IOM connections

Mounting and Installing the Power Supply



WARNING

Personal injury or death could occur and the equipment could be damaged beyond repair if this precaution is not observed!

- Before installation, turn off the external circuit breaker which supplies power to the system, including door locks.
- Before connecting the device to the power supply, verify that the output voltage is within specifications of the power supply.
- Do not apply power to the system until after the installation has been completed.

Power Supply Recommendations

FOR READERS

DC Power Supply:

- Power must be provided to the IdentIPoint readers from a UL294 and/or UL1076 listed power supply for access control or one approved by local authority having jurisdiction.
- Power supply should be 12-24VDC.
- When powered by an external DC source such as the above, IdentIPoint readers provide a power output for powering devices like the IOM or a door strike. The max current provided by the reader in this case is 300mA at 1.5 V less than the input voltage.
- The IdentIPoint readers consume a maximum of 12W power when supplying power to IOMs and/or other external devices such as a door strike or magnetic lock relay.
- Any UL Security listed power supply may be used such as the Honeywell HP400ULPD8CB power supply.

NOTE: For UL294 installations, only UL294 and/or UL1076 listed power supplies should be used for reader and lock power with required 72 hour battery backup.

Power-over-Ethernet

1. If Power-over-Ethernet (PoE) devices are used to power the IdentIPoint readers, they must conform to the IEEE 802.3af standard. See section *Power over Ethernet (PoE) wiring of Wiring the Readers and IOM* topic for details on selecting PoE devices.
2. When powered by an IEEE802.3af compliant PSE (Power Supply Equipment), IdentIPoint readers provide a power output for powering devices like the IOM or a door strike. The max current provided by the reader in this case is 300mA at 10.5VDC.
3. The IdentIPoint readers consume a maximum of 12W power when supplying power to IOMs and/or other external devices such as a door strike or magnetic lock relay.
4. Where it is not feasible to use PoE switches, PoE mid-spans may be alternatively used.

NOTE: Use of PoE is not a UL294 listed configuration and should not be used on projects where a UL294 certificate will be issued.

FOR IOM

1. Power must be provided to the IdentIPoint IOM from a UL294 and/or UL1076 listed power supply for access control or one approved by local authority having jurisdiction.
2. Power supply for IOM should be 12-24VDC.
3. Power consumption is 1.2W max.

NOTE: For UL294 installations, only UL294 and/or UL1076 listed power supplies should be used for reader and lock power with required 72 hour battery backup.

Circuit Protection for Readers and IOM

1. IdentIPoint readers and the IOM are able to withstand power on wrong terminal up to 24VDC on any of the exposed terminals of the reader.
2. IdentIPoint readers and the IOM are able to withstand power connection of up to 24VDC with reverse polarity.
3. IdentIPoint readers and IOM are able to withstand I/O short circuit on all inputs and outputs.

Installation Instructions

1. Mounting: The power supply should be installed in accordance with all applicable codes and standards.
2. Power Supply Input Connection: Before connecting power review the entire wiring diagram provided with the power supply for correct installation. Make input connections as instructed in the manual provided with the power supply.

NOTE: For countries that use input voltage other than 120VAC, check the available literature on the power supply for details on configuring the power supply to accept 230VAC input voltage.

3. Output Connections: Connect the power supply outputs to the desired devices observing polarity. See Table.2 for wire sizes and distances.



WARNING

To reduce risk of electric shock, do not expose unit to rain or excess moisture, and disconnect power before servicing unit. For continuous protection against hazards, replace fuses only with exact type and rating. A readily accessible switched circuit breaker must be available to disconnect main power as required. All 120V wiring should be routed so that it cannot touch 24V wiring; minimum spacing 3/8" (0.953cm). Installation and servicing should only be made by qualified personnel; contains no user-serviceable parts. Install in accordance with all local regulations and the National Electrical Code.

Maintenance

The power supply unit should be tested at least once a year to verify correct operation in accordance with the following recommendations:

Output Voltage Test - Voltage output should be tested under normal load conditions to verify correct levels.

Battery Test - Battery should be checked for full charge under normal load conditions. This check should verify correct voltage at both battery terminals and also at the battery output

point on the board to ensure the integrity of all connecting wiring. The battery should be replaced every 4 years or more often under severe conditions.

WIRING THE READERS AND IOM

General Descriptions

Power to the Reader:

Power can be supplied to the IdentIPoint reader either via the Ethernet cable when it is connected to a router/switch that is equipped with PoE (Power over Ethernet) PSE (Power Supply Equipment) feature, or through a 12-24VDC power source.

NOTE: The PoE PSE can supply power up to 12.95 Watt. It can supply power for one reader, one door strike/magnetic lock which consumes a steady current of less than 300mA (e.g. ASSA ABLOY HES 5200) and one IOM. For the IOM module, DC 12V is needed.

Use of PoE is not a UL294 listed configuration and should not be used on UL294 applications.

Data Communication:

Each IdentIPoint reader is equipped with an RJ45 connector for Ethernet communication. It also has a wireless LAN module that supports IEEE802.11b/g. The reader can communicate with one or more IOMs via the RS485 bus.

NOTE: Wifi network configuration is not a UL294 listed configuration and should not be used on UL294 applications.

The RS485 bus is a multi-drop 2-wire bus running differential signal in half duplex. A third wire, the common ground, is also recommended for more reliable communication. Multiple IOM units can be attached to an IdentIPoint reader through this bus in daisy chain mode. See Fig.24.

NOTE: It is recommended not to attach more than 4 IOM units to the RS485 bus to maintain a reasonable signal/response time delay between the reader and IOMs.



CAUTION

Transmission Protection The system may require external lightning protection. For details, refer to **Lightning Protection** topic.

Supervised Analog Input (SAI):

The Supervised Analog Input is designed to detect supervisory loop tamper. See section *Supervisory Analog Input (SAI) termination circuit* of *Wiring Other Devices* topic for details. Such a loop circuit can be connected to the SAI of an IdentIPoint reader as well as the IOM. This loop can detect tampering by shorting across or cutting the loop. Four states can be detected by the IdentIPoint device: open, short, cut and closed.

Digital Input (DI) (IOM only):

The Digital Input is an active high input, which can be read by the IOM and reported back to the reader through the RS485 interface.

Digital Output (DO)

The Digital Output is a current sinking output, capable of sinking up to 1A at the rated supply voltage. The output can thus be used to drive the door strike/magnetic lock, lights as well as other Digital Inputs or Supervisory Inputs. See Figures 25 through 28.

Wire the Readers and IOM

1. Run the field wiring to the readers as per the job drawings. Figures 21 through 24 show typical wiring schemes for IdentIPoint devices. Wires of a minimum gauge of 18 AWG are recommended for all wiring with the upper limits specified for some applications. See Table.2 for details on wire sizes and maximum permissible distances. 18 AWG wires (0.3 sq. mm) must be limited to 1A loading. When used for carrying communication data as in RS485, the wires must be a twisted pair.
2. To power the reader, plug the Molex terminal into the J9 port of the reader such that the red and black wires of the terminal, connected to the +ve and -ve pins of the power supply connect with pins 1 (Power IN) and 2 (Power GND) of the J9 port.
3. Ensure the other wires of the Molex terminal are connected to the correct corresponding wires from the other devices such as IOMs, door sensors, door strikes etc. (see *Detailed Wiring Diagrams* and *Wiring Other Devices* topics and Fig.11). For wires that are not used, ensure proper insulation at the free ends.
4. To power the IOM, plug the terminal block into the J1 port of the IOM such that the wires connected to the +ve and -ve pins of the power supply, connect with the pins for DC-IN and GND of the J1 port. The IOM may also be alternatively powered through an IdentIPoint reader (see Fig.22).
5. Ensure the other ports of the IOM are similarly connected to the correct corresponding wires from the other devices such as readers, door sensors, door strikes etc. (See *Detailed Wiring Diagrams* and *Wiring Other Devices* topics and Fig.18).
6. Use proper crimping and/or insulation while connecting the wires.

Grounding Recommendations

The FRAME-GROUND signal (pin 10 of J10) of the reader has to be connected to the POWER-GND at all times to ensure good ESD protection and low electromagnetic radiation.

The FRAME-GROUND signal (port J3) of the IOM has to be connected to the POWER-GND before making any other connections to minimize the introduction of error in the RS485 communication line during hot signal insertion. It also should be the last signal to be disconnected.

NOTE: FRAME-GROUND is also known as CHASSIS-GROUND in some countries including USA.

Power Wiring

IMPORTANT

Use a shielded power cable with a three-pin (or as per local regulations) plug to draw mains power for the power supply assembly. (The shielded wire is required to meet FCC RF radiation limits.)

To route the power wiring

1. Using proper conduits, route the input power cable from the mains supply to the input block of the power supply.
2. Route the +ve and -ve pairs of wires from the output block of the power supply out of the power supply enclosure via proper conduits.

3. Connect the +ve and -ve of wires to IdentIPoint devices. For readers, connect the +ve to the red and the -ve to the black wires of the 9-pin Molex terminal respectively. (See Fig.6 for details on Molex terminal wire colors.)

Tamper Protection

IMPORTANT

IdentIPoint readers are equipped with tamper protection features. They must be permanently mounted before commissioning. Attempting to open a reader case without putting it in maintenance mode will disable the reader, and require recommissioning. For details on how to deal with a tampered reader please refer the EBI documentation set.

Table 2. Wire Sizes and Distances

Connection	Wire Gauge	Maximum Distance	Minimum number of conductors	Shielding
Power Source to Device (Reader or IOM)	18 AWG (0.8mm ²) to 15 AWG (1.7mm ²)	See reader/IOM power requirements (section <i>Power Supply Recommendations of Assembly, Mounting and Installation</i> topic) and compensate for drop in voltage.	3	Unshielded cable recommended
Reader/IOM to Digital Inputs	18 AWG (0.8mm ²)	100m	2 per i/p	Optional
Reader/IOM to Digital Output or Lock	18 AWG (0.8mm ²) to 15 AWG (1.7mm ²)	100m subject to adequate power reaching the output device or lock	2 per o/p	Required for power cable connected to output device or lock
Reader to IOM (Power)	18 AWG (0.8mm ²) to 15 AWG (1.7mm ²)	See IOM power requirements (section <i>Power Supply Recommendations of Assembly, Mounting and Installation</i> topic) and compensate for drop in voltage.	2	Required
Reader to IOM (RS485 comm.)	18 AWG (0.8mm ²)	500m	3	Recommended
Reader to IOM (other than Power and RS485 comm.)	18 AWG (0.8mm ²)	100m	2 per connection type	Optional
IOM to IOM (RS485 comm.)	18 AWG (0.8mm ²)	500m	3	Recommended
Ethernet	CAT5	100m	Standard as in CAT5	Recommended

EACH DOOR STRIKE REQUIRES A 14507020-001 DIODE SUPPRESSION NETWORK. DOOR STRIKE MAY DRAW A MAXIMUM CURRENT OF 2A; REGULATED 12/ 24 VDC. DOOR STRIKE AND REX MUST BE UL LISTED. SEE FIG.25 THROUGH FIG.28 FOR TYPICAL DIODE SUPPRESSION NETWORK WIRING.

DOOR CONTACTS MUST BE UL LISTED. MAXIMUM WIRE LENGTH 500 FT (152 M). WIRE TYPE 18 AWG (0.8 SQ MM), 50 OHM 60 mA MAXIMUM. DOOR CONTACTS ARE ONLY INTENDED FOR MONITORING DOOR POSITION. THEY ARE NOT INTENDED FOR CONNECTION TO A BURGLAR ALARM PANEL

EXIT SWITCH: WIRING MUST BE COMPLETED WITHIN THE PROTECTED AREA OR NOT READILY ACCESSIBLE OUTSIDE THE PROTECTED AREA. THE EXIT SWITCH MUST BE UL LISTED.

ALL WIRING MUST CONFORM TO APPLICABLE LOCAL CODES, ORDINANCES, AND REGULATIONS.

DO NOT ROUTE COMMUNICATION WIRES WITH POWER OR LOCKING DEVICES.

NOTE: FOR COMMUNICATION CIRCUITS AND OTHER APPLICABLE WIRING CIRCUITS WHERE WIRING ENTERS AND EXITS THE BUILDING, REFER TO TABLE 13 FOR APPROPRIATE LIGHTNING PROTECTOR USAGE.

Power over Ethernet (PoE) wiring

PoE integrates data and power on the same wires, without interfering with concurrent network operation. PoE delivers 48V of DC power over unshielded twisted-pair wiring for terminals consuming less than 13 watts of power.

PoE can be used with IEEE 802.3af compliant devices in either of the two modes described in Table.3 and shown in Fig.19 and Fig.20. The detailed pin-outs are shown in Table.4.

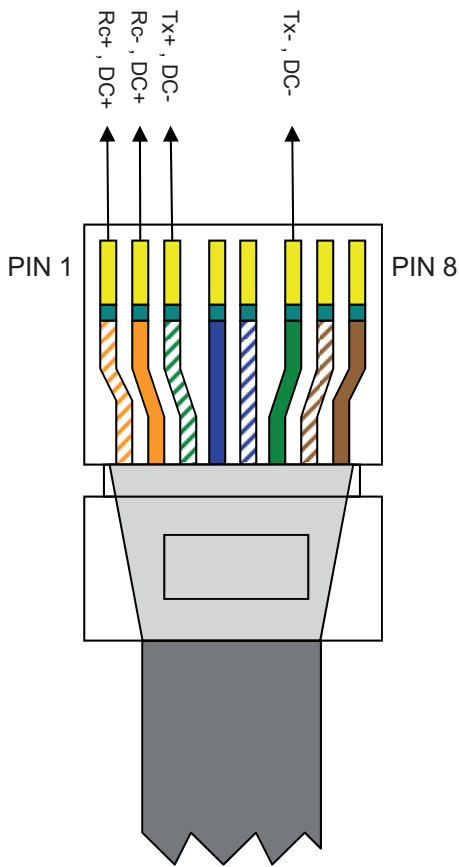

Fig. 19. Straight cable pinouts for PoE in Mode A

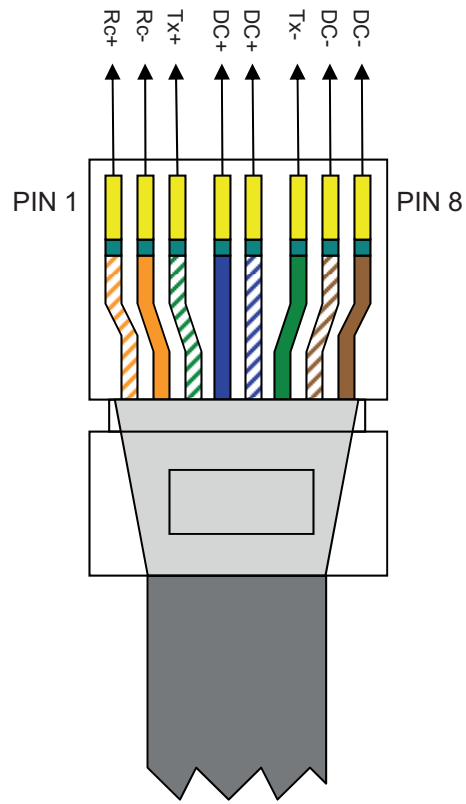

Fig. 20. Straight cable pinouts for PoE in Mode B

Table 3. PoE Modes

Pin	Model A	Model B
1	Vport positive	
2	Vport positive	
3	Vport negative	
4		Vport positive
5		Vport positive
6	Vport negative	
7		Vport negative
8		Vport negative

Table 4. PoE pin-outs for the two modes.

STANDARD	SOURCE									LOAD		REMARKS
	Source Voltage	Ethernet RJ-45 connector pin number								Load Voltage	DC Load Connector	
		1	2	3	4	5	6	7	8			
IEEE 802.3af using data pairs	48 V DC protected	RX DC +	RX DC +	TX DC-	spare	spare	TX-DC	spare	spare	(embedded)		Industry standard for embedded PoF
IEEE 802.3af using spare pairs	48 V DC protected	RX	RX	TX	DC +	DC +	TX	DC -	DC -	(embedded)		Industry standard for embedded PoF

NOTE: Use of PoE is not a UL294 listed configuration and should not be used on UL294 applications.

DETAILED WIRING DIAGRAMS

Single Reader with REX and without IOM

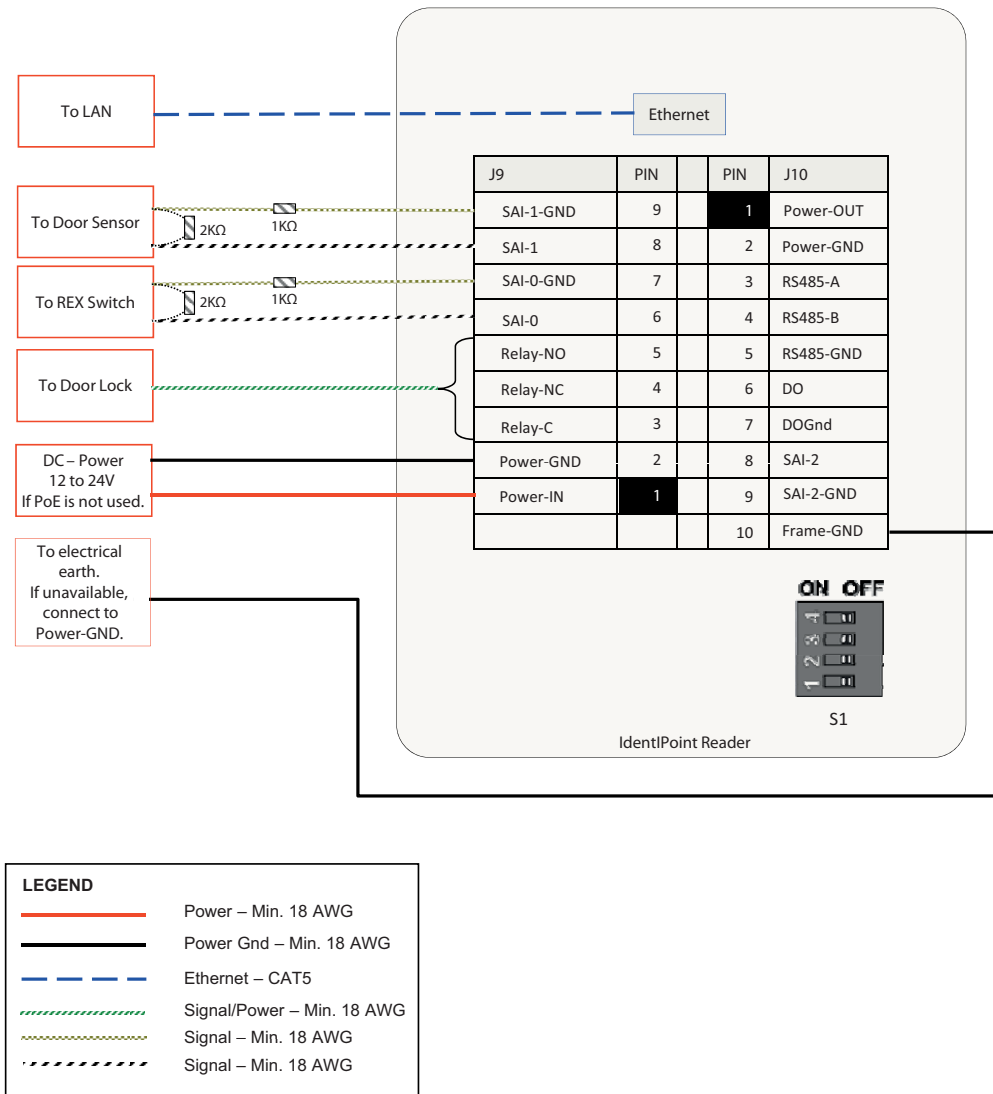

Fig. 21. Connections for single reader with REX and without IOM

In the above configuration, one IdentIPoint reader operates in stand-alone mode to control door access. It authenticates users as well as releases the door lock using its relay contact.

Minimum Connections:

1. Connect the Ethernet/PoE cable to the RJ45 port of the reader through the CAT5 pigtail. (Frame-GND connection to building GROUND Earth is recommended for better electro-static discharge resilience.) See Fig.7.
2. If PoE switch is not used, connect a 12-24VDC power supply to pins 1-2 (Power-IN - Power-GND) of port J9 of the reader. See section *Wire the Readers and IOM of Wiring the Readers and IOM* topic for details on power supply connections.
3. Connect pin(s) 3/4/5 (Relay-C/Relay-NC/Relay-NO) of port J9 to the door lock depending on the type of lock (magnetic lock or door strike) used and the safety codes to be followed. Also connect a power line to the lock. See *Wiring Other Devices* topic for detailed wiring of locks.
4. Connect pins 6-7 (SAI-0 - SAI-0-GND) and 8-9 (SAI-1 - SAI-1-GND) to a Request-to-Exit (REX) switch and door sensor with proper termination circuit as described in section *Supervisory Analog Input (SAI) termination circuit of Wiring Other Devices* topic. An additional sensor can be connected to SAI-2 of port J10.

NOTE: REX and Door Sense support only Normally Closed and not Normally Open positions, i.e., REX is detected when SAI switch is open, Door is sensed as open when SAI switch is open.

Single Reader with REX and IOM

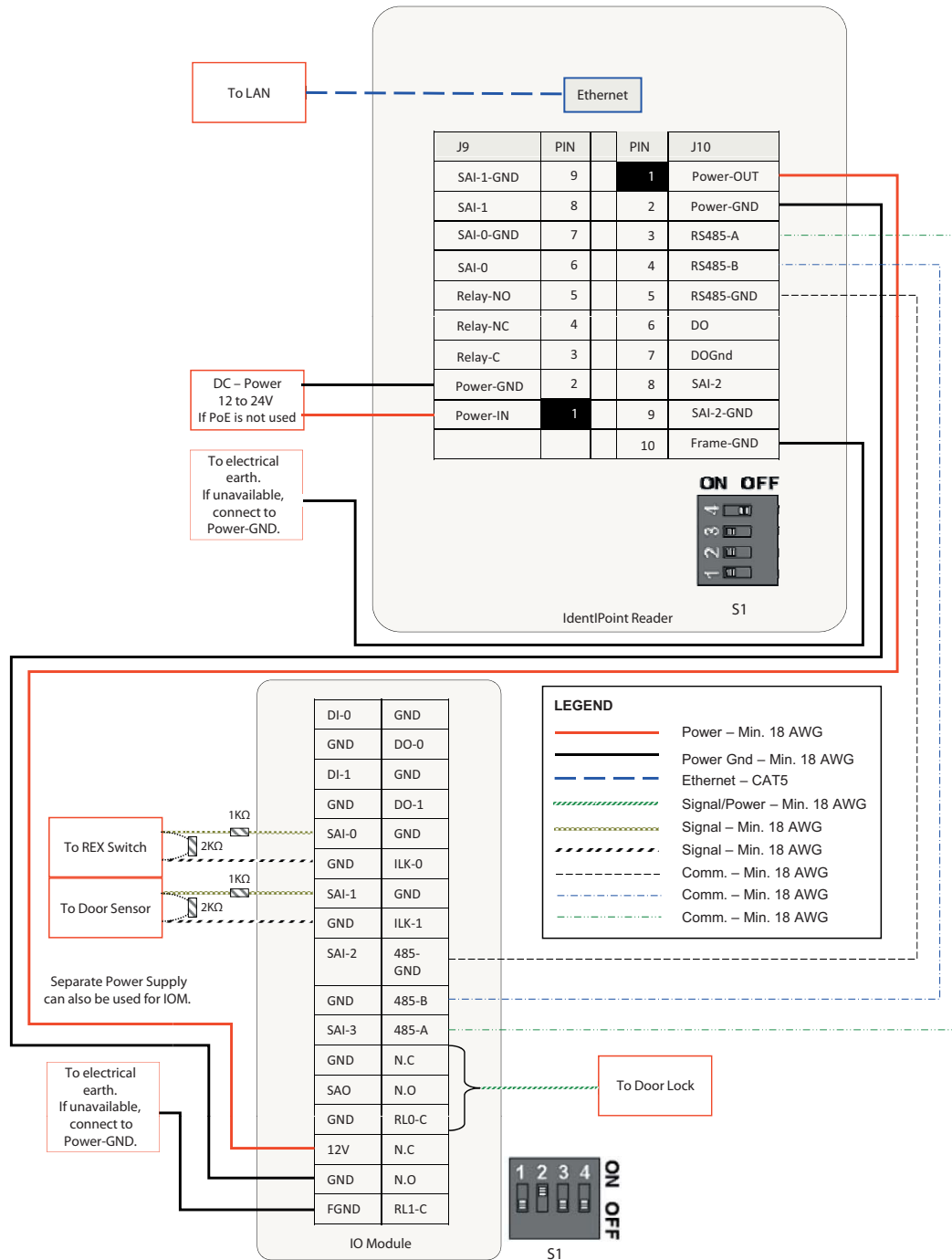

Fig. 22. Connections for single reader with REX and IOM (S1 DIP switch settings shown)

In the above configuration, one IdentIPoint reader and one IOM are connected through a secure RS485 connection to control door access. While the IdentIPoint reader authenticates users, the IOM releases the door lock upon the reader's command. A Request-to-Exit (REX) switch can be connected to the IOM's Digital Input or Supervised Analog Input (SAI). The reader can read the state of the REX switch and give instructions to the IOM regarding the door.

Minimum Connections:

1. Connect the Ethernet/PoE cable to the RJ45 port of the reader through the CAT5 pigtail. (Frame-GND connection to building GROUND Earth is recommended for better electro-static discharge resilience.) See Fig.7.
2. If PoE switch is not used, connect a 12-24VDC power supply to pins 1-2 (Power-IN - Power-GND) of port J9 of the reader. See section *Wire the Readers and IOM* of *Wiring the Readers and IOM* topic for details on power supply connections.
3. Connect the RS485-A, RS485-B and RS485-GND (pins 3, 4 and 5 on port J10 of the reader) to their corresponding RS485 points on J14 of the IOM. See section *RS485 Communication and Termination Setting of Connector and Switch Descriptions* topic for details on RS485 wiring and termination settings. Set the S1 DIP switch on the reader and the IOM accordingly.

4. Power to the IOM can be given by connecting the Power-OUT - Power-GND (pins 1-2 on J10) of the reader to 12V - GND (J1) respectively of the IOM. Alternatively, power to the IOM can also be supplied through a separate 12-24VDC power supply or a common rail.
5. Connect pin(s) NC/NO/RL0-C or RL1-C (J12/J13) of the IOM to the door lock depending on the type (magnetic lock or door strike) used and the safety codes to be followed. Also connect a power line to the lock. Detailed wiring for locks is shown in *Wiring Other Devices* topic.
6. Connect J6, J7, J8 or J9 of the IOM (SAI-n - SAI-n-GND) to a door sensor and a REX switch with proper termination circuit as described in section *Supervisory Analog Input (SAI) termination circuit* of *Wiring Other Devices* topic. Alternatively, the REX switch can also be connected to DI-0 - GND or DI-1 - GND (J4 or J5) of the IOM without any termination circuit.

NOTE:

- The IOM must be installed on the secure side of the door.
- The RS485 ground signal is not necessary if the IOM is powered by the IdentIPoint reader or if there is a common ground available between the two units.
- REX and Door Sense support only Normally Closed and not Normally Open positions, i.e., REX is detected when SAI switch is open, Door is sensed as open when SAI switch is open.

Two Readers with IOM

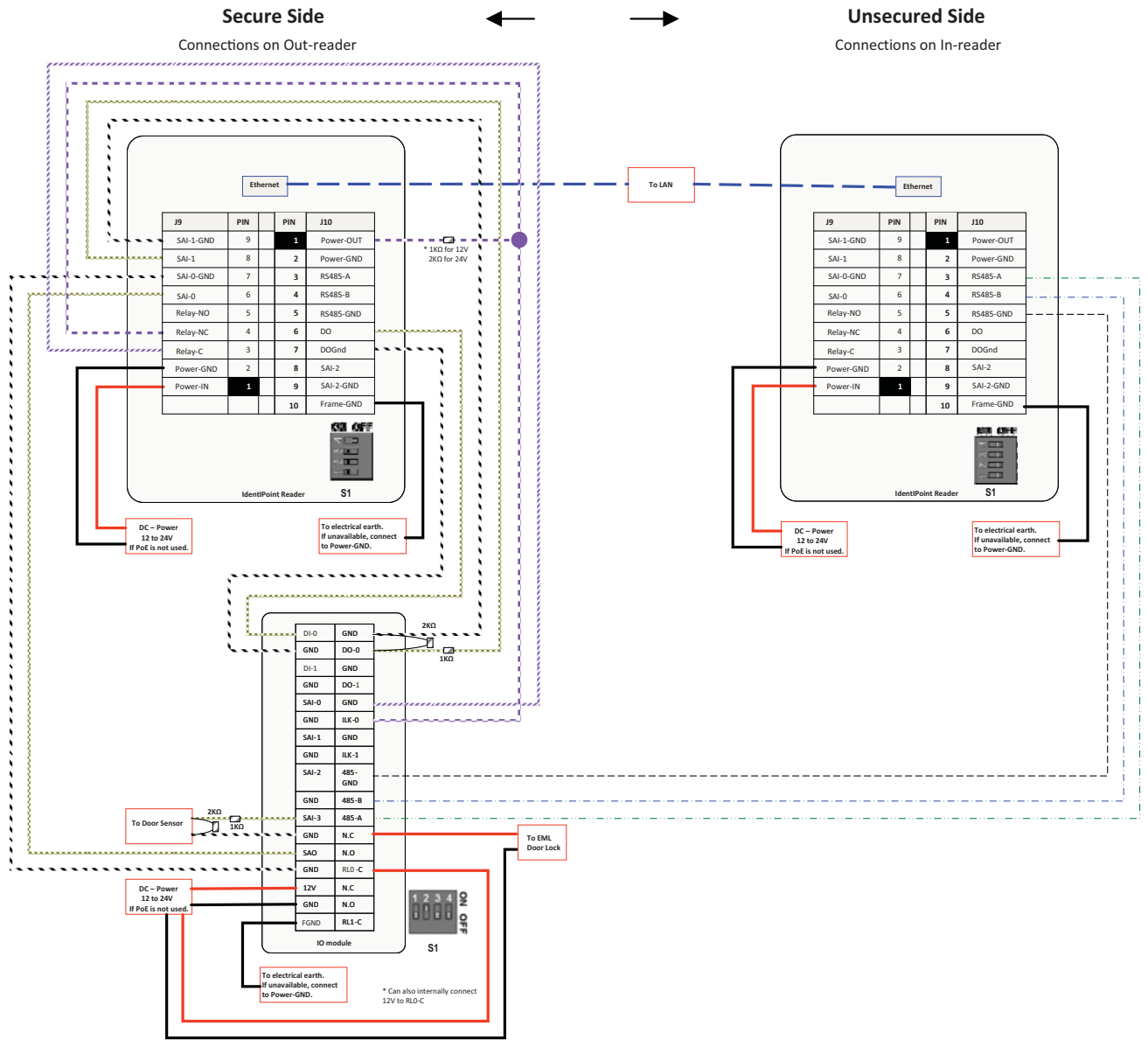

Fig. 23. Connections for two readers with IOM (S1 DIP switch settings shown)

In the above configuration, two IdentIPoint readers and one IOM are inter-connected to control an IN/OUT door. While the IdentIPoint readers authenticate users on both sides of the door, the IOM releases the door lock upon the readers' commands. A Request-to-Exit (REX) button is not required in this setup.

Minimum Connections:

1. Connect the Ethernet/PoE cable to the RJ45 port of the reader through the CAT5 pigtail. (Frame-GND connection to building GROUND Earth is recommended for better electro-static discharge resilience.) See Fig.7.
2. If PoE switch is not used, connect a 12-24VDC power supply to pins 1-2 (Power-IN - Power-GND) of port J9 of the reader and pins 12V - GND (J1) of the IOM through a common rail. This is the recommended power supply configuration as it is necessary to provide a common ground to all three devices. See section *Wire the Readers and IOM* of *Wiring the Readers and IOM* topic for details on power supply connections.
3. Connect the RS485-A, RS485-B and RS485-GND (pins 3, 4 and 5 on port J10 of the In-reader) to their corresponding RS485 points on J14 of the IOM. See section *RS485 Communication and Termination Setting of Connector and Switch Descriptions* topic for details on RS485 wiring and termination settings. Set the S1 DIP switch on the In-reader and the IOM accordingly.

4. Connect pin(s) NC/NO/RL0-C or RL1-C (J12/J13) of the IOM to the door lock depending on the type (magnetic lock or door strike) used and the safety codes to be followed. Also connect a power line to the lock. Detailed wiring for locks is shown in *Wiring Other Devices* topic.
5. Connect J6, J7, J8 or J9 of the IOM (SAI-n - SAI-n-GND) to a door sensor with proper termination circuit as described in section *Supervisory Analog Input (SAI) termination circuit* of *Wiring Other Devices* topic.
6. Make all other interconnections between the Out-reader and IOM as shown in Fig. 23.

NOTE:

- The Out-reader must be installed on the secure side of the door along with the IOM.
- For a single door controlled by two readers with IOM the door sensor shall always be wired to SAI-3 of the IOM.
- The RS485 ground signal is not necessary if the IOM is powered by the IdentIPoint reader or if there is a common ground available between the two units.
- The resistors need to be connected at proper terminals as shown in the diagram.
- REX and Door Sense support only Normally Closed and not Normally Open positions, i.e., REX is detected when SAI switch is open, Door is sensed as open when SAI switch is open.

Reader with Multiple IOMs

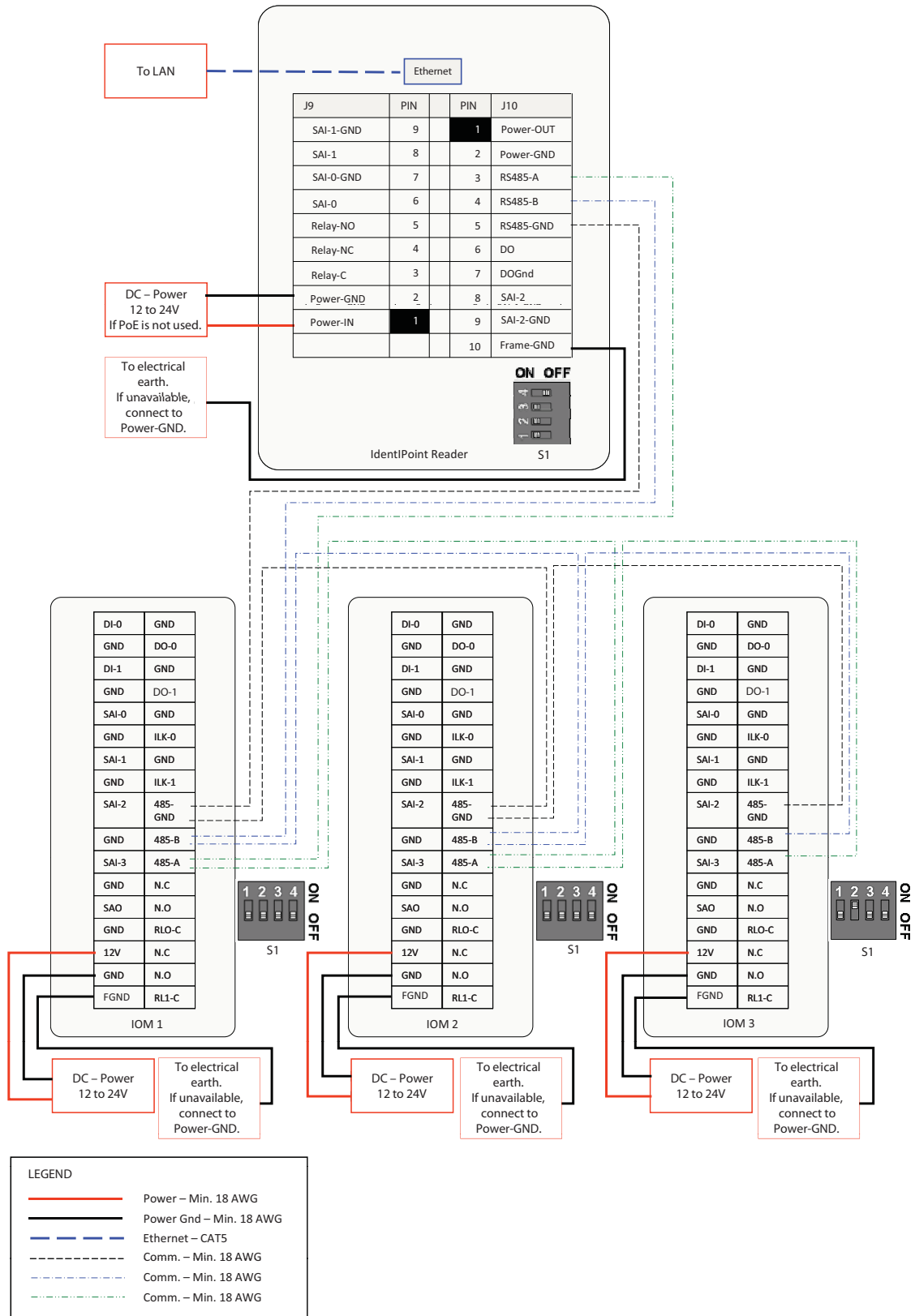

Fig. 24. Connections for reader with three IOMs on a RS485 bus (S1 DIP switch settings shown)

In the above configuration, three IdentPoint IOMs are inter-connected with a reader in a master-slave configuration. Such connections are necessary when a reader needs to connect with more than one IOM.

Minimum Connections:

1. Connect the RS485-A, RS485-B and RS485-GND (pins 3, 4 and 5 on port J10 of the In-reader) to their corresponding RS485 points on J14 of IOM1. See section *RS485 Communication and Termination Setting of Connector and Switch Descriptions* topic on RS485 wiring and termination settings. Set the S1 DIP switch on the reader accordingly.
2. Connect the RS485-A, RS485-B and RS485-GND on J14 of IOM 1 to their corresponding RS485 points on J14 of IOM2 and similarly connect IOM2 to IOM3 in a daisy chain. See section *RS485 Communication and Termination Setting of Connector and Switch Descriptions* topic for details on RS485 wiring and termination settings. Set the S1 DIP switch on the IOMs accordingly.
3. Make all other connections between the reader, IOMs and other devices as needed and explained in section *Single Reader with REX and IOM of Detailed Wiring Diagrams* topic.

NOTE:

- Although, Fig. 24 shows separate power supplies for all the devices, it is also possible to provide them power from a single power source as long as it delivers the required power for all devices.
- The IOMs must be installed on the secure side of the door.
- The RS485 ground signal is not necessary if the IOM is powered by the IdentPoint reader or if there is a common ground available between the two units.

WIRING OTHER DEVICES

⚠ WARNING

Use suppressors on door strikes and magnetic locks wherever required. Use 14507020-001 diode suppression network. Honeywell recommends only DC locks. See Fig.25 through Fig.28 for typical diode suppression network wiring.

Strike Latch

Strike latch connected directly to the reader:

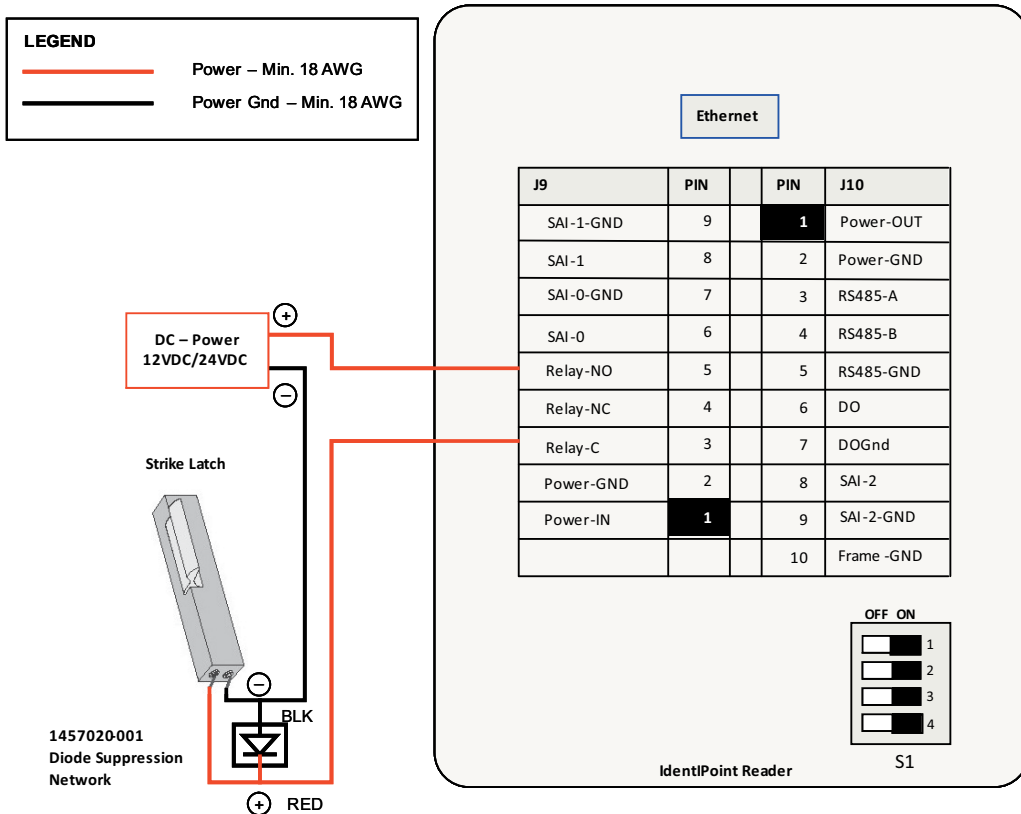

Fig. 25. Connections between reader and strike latch

1. Connect 12VDC+ of the power supply to pin 5 (Relay-NO) or pin 3 (Relay-C) of the reader and 12VDC- to the -ve pin of the strike latch.
2. Connect either pin 5 (Relay-NO) pin 3 (Relay-C), whichever is left free, of the reader to the +ve pin of the strike latch.

In this setup, the door will remain locked in the absence of power and will be unlocked when power is provided. If the reader is powered off in this situation, the door will remain locked.

NOTE: The above describes one way of wiring the strike latch. Wiring must be done strictly as per the stipulated safety codes that the building must follow. Accordingly, the wiring would be either done in a fail-safe or fail-secure configuration.

For description of reader pins refer to Table.5 and Table.6.

Strike latch connected to the IOM:

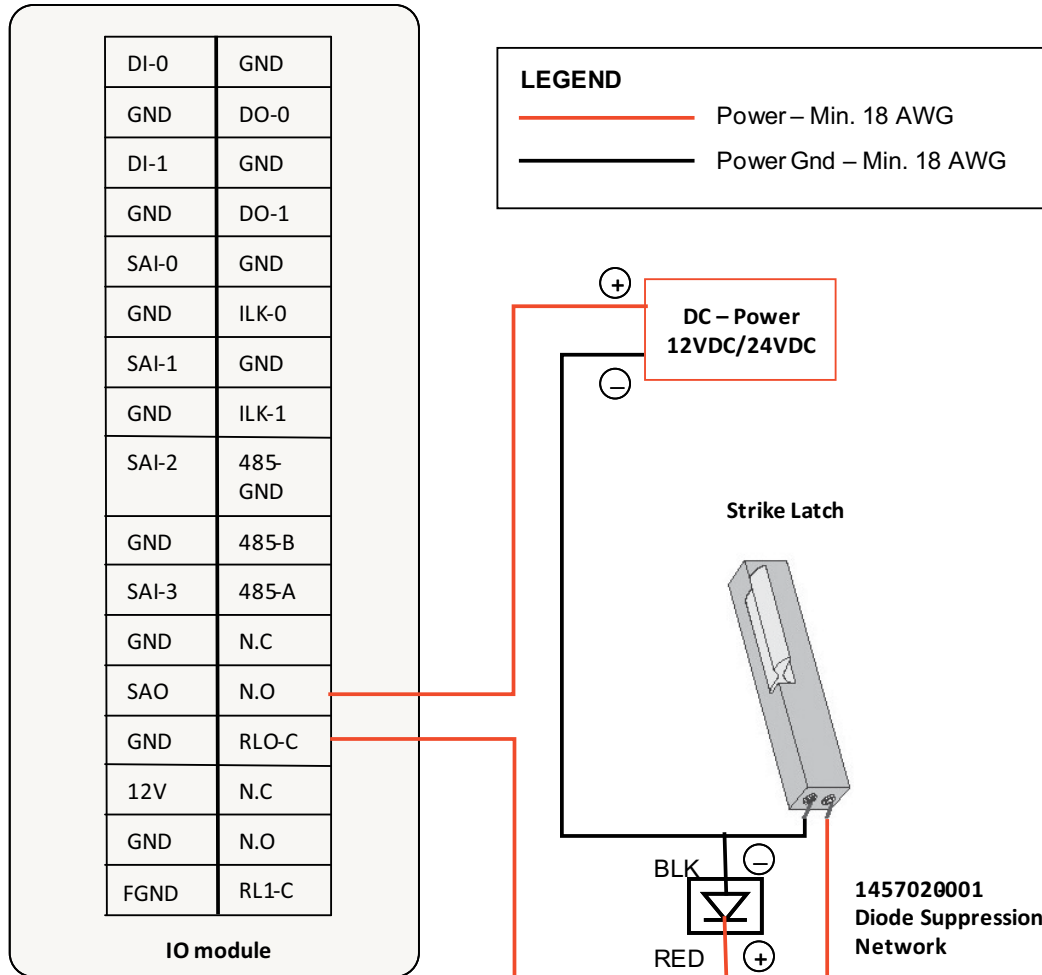

Fig. 26. Connections between IOM and strike latch

1. Connect 12VDC+ of the power supply to either the NO or Common pin of Relay 0 or 1 (J12 or J13) of the IOM, and the 12VDC- to the -ve pin of the strike latch.
2. In the same port (J12 or J13), connect the NO or Common, whichever is left free, to the +ve pin of the strike latch.

In this setup, the door will remain locked in the absence of power and will be unlocked when power is provided. If the reader is powered off in this situation, the door will remain locked.

NOTE: The above describes one way of wiring the strike latch. Wiring must be done strictly as per the stipulated safety codes that the building must follow. Accordingly, the wiring would be either done in a fail-safe or fail-secure configuration.

For description of IOM pins refer to Table.8.

Magnetic Lock

Magnetic lock connected directly to the reader:

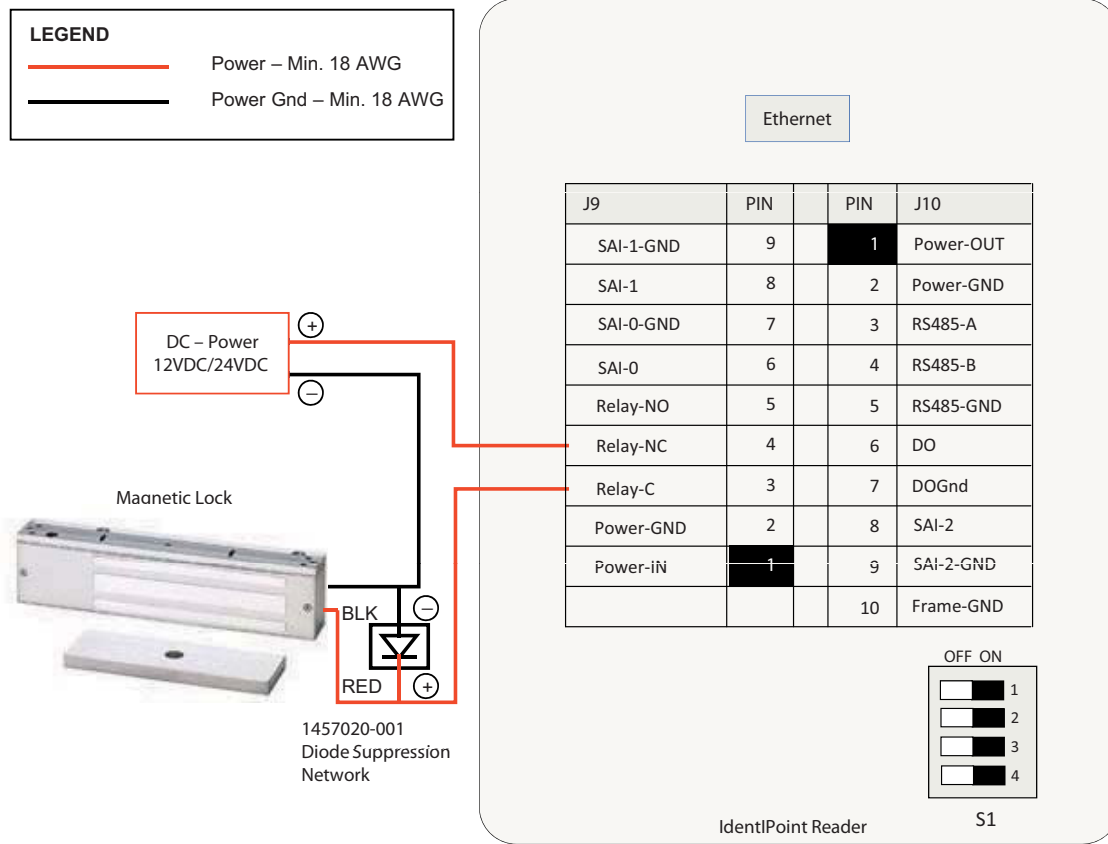

Fig. 27. Connections between reader and magnetic lock

1. Connect 12VDC+ of the power supply to pin 4 (Relay-NC) or pin 3 (Relay-C) of the reader and 12VDC- to the -ve pin of the magnetic lock.
2. Connect either pin 4 (Relay-NC) or pin 3 (Relay-C), whichever is left free, of the reader to the +ve pin of the magnetic lock.

In this setup, the door will remain locked as long as power is provided and will unlock in the absence of power. If the reader is powered off in this situation, the door will unlock.

NOTE: The above describes one way of wiring the magnetic lock. Wiring must be done strictly as per the stipulated safety codes that the building must follow. Accordingly, the wiring would be either done in a fail-safe or fail-secure configuration.

For description of reader pins refer to Table.5 and Table.6.

Magnetic lock connected to the IOM:

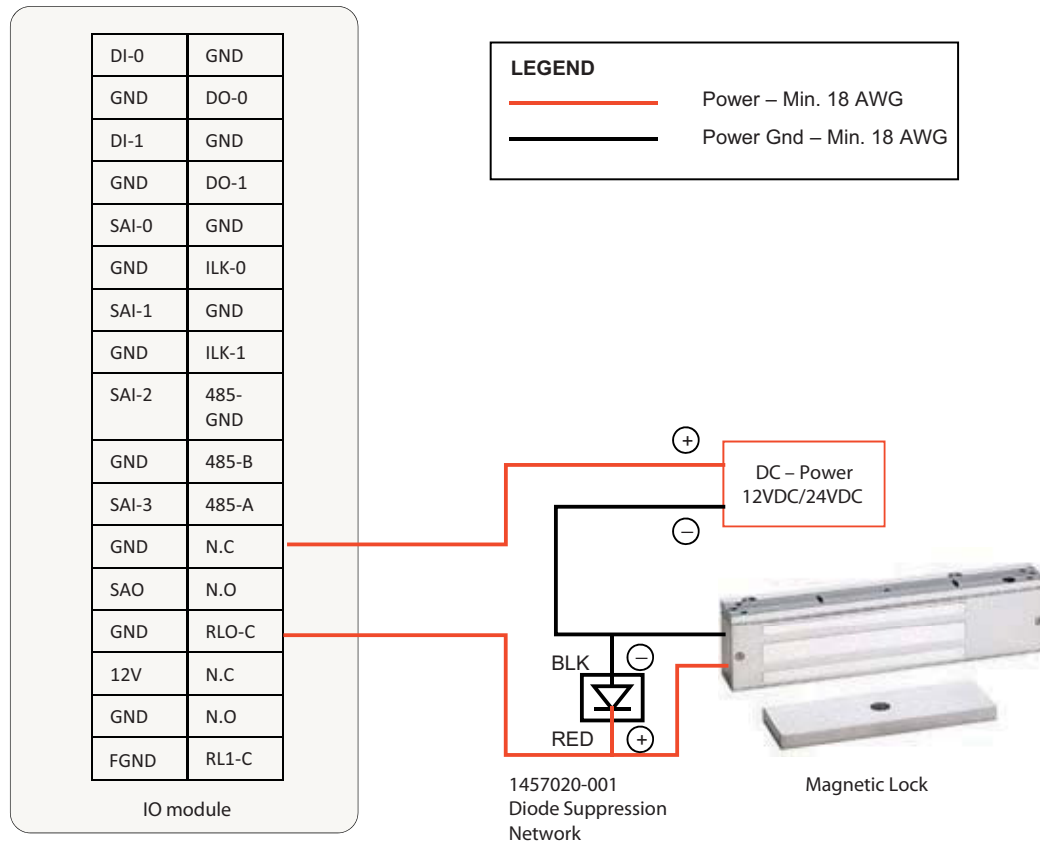

Fig. 28. Connections between IOM and magnetic lock

1. Connect 12VDC+ of the power supply to either the NC or Common pin of Relay 0 or 1 (J12 or J13) of the IOM, and the 12VDC- to the -ve pin of the magnetic lock.
2. In the same port (J12 or J13), connect the NC or Common, whichever is left free to the +ve pin of the magnetic lock.

In this setup, the door will remain locked as long as power is provided and will unlock in the absence of power. If the reader is powered off in this situation, the door will unlock.

NOTE: The above describes one way of wiring the magnetic lock. Wiring must be done strictly as per the stipulated safety codes that the building must follow. Accordingly, the wiring would be either done in a fail-safe or fail-secure configuration.

For description of IOM pins refer to Table.8.

Supervisory Analog Input (SAI) termination circuit

⚠ WARNING

Exit switch wiring must be completed within the protected area or not readily accessible outside the protected area.

A typical termination circuit for SAI is shown in Fig.29:

1. Connect a 1 K Ω resistor (0.5W axial type, 5% tolerance) in series with SAI-n and the sensor switch.
2. Connect a 2 K Ω resistor (0.5W axial type, 5% tolerance) in parallel with the input pins and the sensor switch.

Such a termination circuit can be connected to the SAI of an IdentIPoint reader as well as the IOM. This loop can detect tampering by shorting across or cutting the loop. Four states can be detected by the IdentIPoint device: open, short, cut and closed.

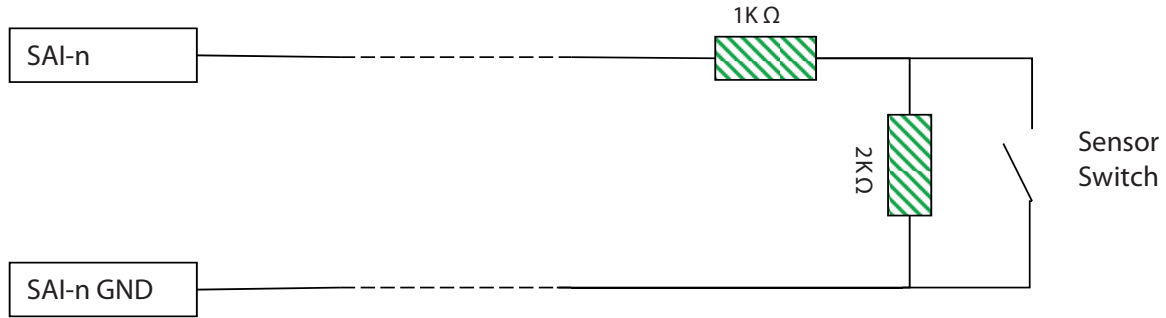

Fig. 29. Connections for Supervisory Analog Inputs

NOTE: REX and Door Sense support only Normally Closed and not Normally Open positions, i.e., REX is detected when SAI switch is open, Door is sensed as open when SAI switch is open.

Table 6. Reader J10 connector signals

CONNECTOR AND SWITCH DESCRIPTIONS

For Readers:

Table 5. Reader J9 connector signals

Connector: J9		
Pin Number	Signal	Connector Wire
1	Power-IN	RED
2	Power-GND	BLACK
3	Relay-Common	ORANGE
4	Relay-Normal Close	WHITE/ ORANGE
5	Relay-Normal Open	WHITE
6	Supervisory Analog Input (SAI) 0	GREEN
7	SAI 0 GND	WHITE/GREEN
8	Supervisory Analog Input (SAI) 1	BLUE
9	SAI 1 GND	WHITE/BLUE

Connector: J10		
Pin Number	Signal	Connector Wire
1	Power Output for Door Strike	RED
2	Ground for Door Strike	BLACK
3	RS485-A	YELLOW
4	RS485-B	WHITE/ YELLOW
5	RS485-GND	GREY
6	Digital Output (Current Sink)	ORANGE
7	Digital Output GND	WHITE/ ORANGE
8	Supervisory Analog Input (SAI) 2	VIOLET
9	SAI2 GND	WHITE/VIOLET
10	Frame GND (ESD GND)	WHITE/BLACK

Table 7. Reader S1 DIP Switch settings

Position	Effect when "ON" (position left)
1	RS485-A pull up
2	RS485 termination
3	RS485-B pull down
4	Wi-fi Disable

For IOM:

Table 8. IOM Connector Signals

Connector		Signal Description
Connector: J1		
1	12V DC Power	12VDC Power Input, tolerate up to 28VDC
2	Power Ground	Power Ground
Connector J2		
1	SAO	Supervisory Analog Output, repeats the input of SAI-3
2	SAO-GND	Supervisory Analog Output Ground
Connector J3		
1	F-GND	Frame Ground (note 1)
2	F-GND	Frame Ground
Connector J4		
1	DIN-0	Digital Input 0 (note 2)
2	DIN-0-GND	Digital Input 0 Ground
Connector J5		
1	DIN-1	Digital Input 1 (note 2)
2	DIN-1-GND	Digital Input 1 Ground
Connector J6		
1	SAI-0	Supervisory Analog Input 0
2	SAI-0-GND	SAI 0 Ground
Connector J7		
1	SAI-1	Supervisory Analog Input 1
2	SAI-1-GND	SAI 1 Ground
Connector J8		
1	SAI-2	Supervisory Analog Input 2
2	SAI-2-GND	SAI 2 Ground
Connector J9		
1	SAI-3	Supervisory Analog Input 3
2	SAI-3-GND	SAI 3 Ground
Connector J10		
1	DO-0	Digital Output 0, current sinking output
2	DO-0-GND	Digital Output 0 Ground
Connector J11		
1	DO-1	Digital Output 1, current sinking output

Connector		Signal Description
2	DO-1-GND	Digital Output 1 Ground
Connector J12		
1	RL-0-Com	Relay 0 Dry Contact Common
2	RL-0-NO	Relay 0 Dry Contact Normal Open
3	RL-0-NC	Relay 0 Dry Contact Normal Close
Connector J13		
1	RL-1-Com	Relay 1 Dry Contact Common
2	RL-1-NO	Relay 1 Dry Contact Normal Open
3	RL-1-NC	Relay 1 Dry Contact Normal Close
Connector J14		
1	RS485-A	RS485 bus A (non-inverting signal) signal
2	RS485-B	RS485 bus B (inverting signal) signal
3	RS485-GND	RS485 bus Ground
Connector J17		
1	InterLock-0	Interlock Input 0 (Relay 0 bypass activation)
2	InterLock-0-GND	Interlock 0 Ground
Connector J18		
1	InterLock-1	Interlock Input 1 (Relay 1 bypass activation)
2	InterLock-1-GND	Interlock 1 Ground
1	12V DC Power	12VDC Power Input, tolerate up to 28VDC

NOTE:

1. Frame-Ground should always be the first signal to connect to and last signal to disconnect from the system.
2. Pulled-up to high level internally.

Table 9. IOM Switch Functions

Switch	Description
S1	RS485 Termination Control DIP switch
S2	Initialization Button
S3	IOM Address set up DIP switch
S4	Cover tamper detection switch

Table 10. IOM S1 DIP switch settings

Position	Description
1	RS485-A pull up
2	RS485 Termination
3	RS485-B pull down
4	Reserved

Table 11. IOM S3 DIP switch settings

Position	Description
1	Address value 1
2	Address value 2
3	Address value 4
4	Address value 8
5	Address value 16
6	Address value 32
7	Address value 64
8	For IOM setup, normally set to OFF

RS485 Communication and Termination Setting



CAUTION

If the Bus wiring enters or exits the building, the protectors listed in Table.13 must be used. Bus length for RS485 must not exceed 500 m end-to-end.

RS485 is a 2-wire balanced multi-drop serial bus, which allows a master unit to send and receive data to and from its slave units. When an IdentIPoint reader is connected to one or

more IOMs, the reader is the master unit while the IOMs are the slave units. Each unit, having its own RS485 address, is connected in parallel to the RS485 bus. The length of the bus must not exceed 1640 ft (500 m), end-to-end. The master always assumes address zero. The master facilitates the communication of data between itself and a particular slave unit in a particular instance. For IOM address setup, see section *IOM Address Set up of Connector and Switch Descriptions* topic.

The RS485 serial signal travels down the stream, usually over unshielded twisted pair cables. A suitable termination resistor has to be put at the end of the RS485 line to absorb the remaining energy on the line to prevent signal reflection. A 100 ohm resistor is chosen as it stays closest to the characteristic impedance of the transmission line.

IdentIPoint readers and IOMs are both equipped with a termination circuit and do not need an external termination resistor. Setting bit 2 on S1 DIP switch to ON introduces a termination resistor on the RS485 line. The units that sit physically on both ends of an RS485 bus should have their RS485 termination turned on. To minimize error signals induced on the RS485 bus during its high-impedance state, it is also recommended to turn on the pull-up and pull-down resistors in the IdentIPoint reader (master) as shown in Fig. 30. See Table.7 and Table.10 for S1 DIP switch settings for readers and IOM.

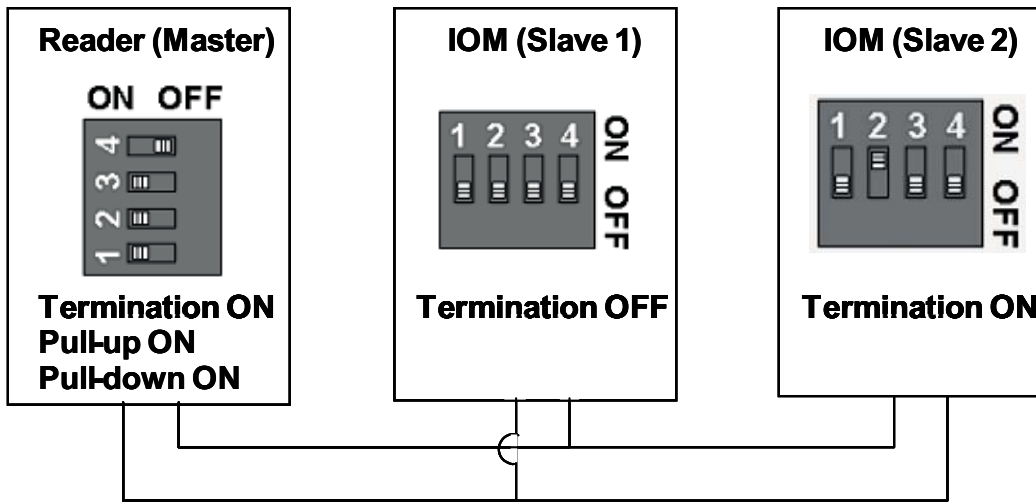

Fig. 30. S1 DIP Switch settings on reader and IOMs for RS485 termination

IOM Address Set up

Each IOM should have its own address. S3 DIP switch on the IOM holds the RS485 address of each unit. The addresses can range from 1 to 127, with position 1 corresponding to $2^0=1$, position 2 to $2^1=2$ and so on as shown in Fig.31. Never use zero as IOM address as zero is reserved for the master device.

To work out the address, select a combination of bit locations on the DIP switch. Each bit has its own value representation. The RS485 address is obtained by adding all ON-bit values. E.g. Decimal value 37 will be obtained by turning ON bits 1, 3 and 6 which is equivalent to $1+4+32$.

NOTE: It is recommended not to attach more than 4 IOM units to the RS485 bus to maintain a reasonable signal/response time delay between the reader and the IOMs. Hence IOM addresses must be from 1 to 4 only. See Fig.32 for S3 DIP switch settings for up to 4 IOMs.

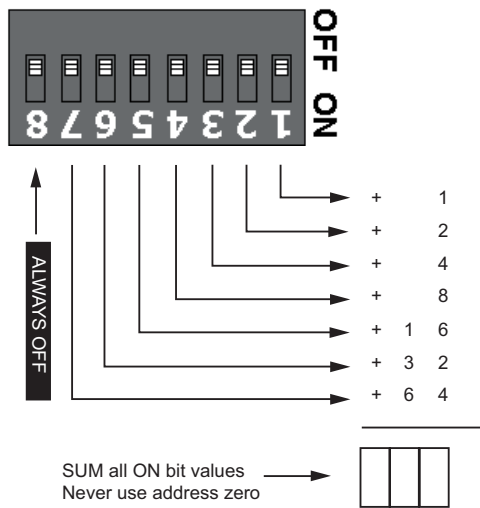

Fig. 31. IOM Address set up



Fig. 32. IOM Address set up - S3 Settings

CONFIGURING THE HARDWARE

The LEDs at the back of the reader glow as follows when power is applied to the device:

- Power - LED glows blue if power is applied to the reader.
- Activity - LED flashes amber when Ethernet cable is connected and Ethernet is in communication; just remains lit in other conditions.
- 10/100 - LED glows green when it is in 100M Ethernet mode; remains unlit in all other conditions.

The LEDs on the front of the IOM glow as follows when power is applied to the device:

Table 12. IOM LED States and Descriptions

Color →	RED	BLINKING RED	GREEN	BLINKING GREEN	AMBER *	BLINKING AMBER *	OFF
LED ↓							
Power	–	–	–	On main power	–	–	Off
Data	No Comm.	Comm. exists but invalid data. Blinks when there is incoming invalid data	All well	Comm. exists with valid incoming data. Blinks when there is incoming or outgoing data	Installation state	Installation state. Blinks when there is incoming or outgoing data	–
Tamper	–	Unit tampered	–	–	–	–	Unit OK

* As the difference between the Red and Amber colors of the LED is not significant, the user is advised to observe the change of color from Red to Amber (or vice versa) by comparing the LED with any other Red LED on the IOM.

IdentIPoint devices can be configured either over Ethernet or Wi-fi.

Ethernet:

- Only works if plugged into a DHCP enabled network
- IP address will be shown on LCD screen
- If no LCD screen, or some distance to the reader, then use the IdentIPoint Sync Application to discover the reader

Wi-fi:

- Need to create an ad-hoc network with the IdentIPoint reader
- IP address of IdentIPoint is 192.168.0.200

NOTE:

- You need to have the Ethernet and wireless networks on two different subnets and not on the same subnet and you need to have matching routes in case a machine is going to connect via both networks.
- Wifi network configuration is not a UL294 listed configuration and should not be used on UL294 applications.

Logging In

1. Enable wireless by presenting any smart card.
2. Create an ad-hoc network with IdentIPoint.
 - SSID is iPAC10.
3. Call up the web interface.
 - http://192.168.0.200.

NOTE: This mode of connecting with the reader will no longer be available after the reader has been discovered and configured by EBI. To regain this capability, the reader's factory reset switch must be activated. The reader can then be reconfigured.

4. Log in to the webpage using the dialog box as shown
 - User: "admin".
 - Password: "password".
 - These should be changed later.

Reader Name

1. Enter a name for the reader
 - This will become the Point Name in EBI.
2. Enter a description for the reader.

Hints:

- Name the reader uniquely.
- Use the reader description to reflect location.

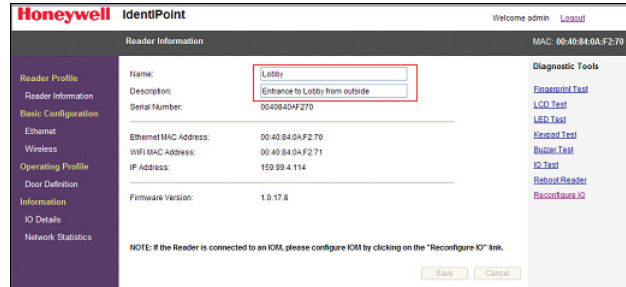

Connection

1. Choose Ethernet parameters.
2. If using wireless, ensure data entered is 100% correct.
 - Perform a "factory reset" if anything goes wrong.

Hint:

- Assign a well known Ethernet IP for a wireless or stand-alone reader.

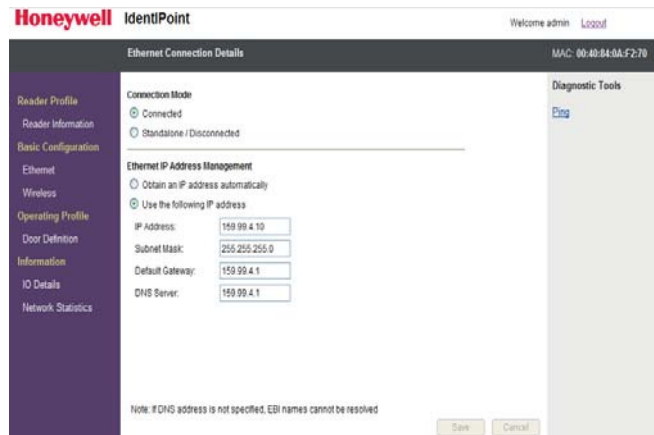

I/O

Out-of-the-box assumes that there is no IO Module.

1. If an IO Module is used, simply click the link and follow the prompts as shown in figures labeled 1 through 5.

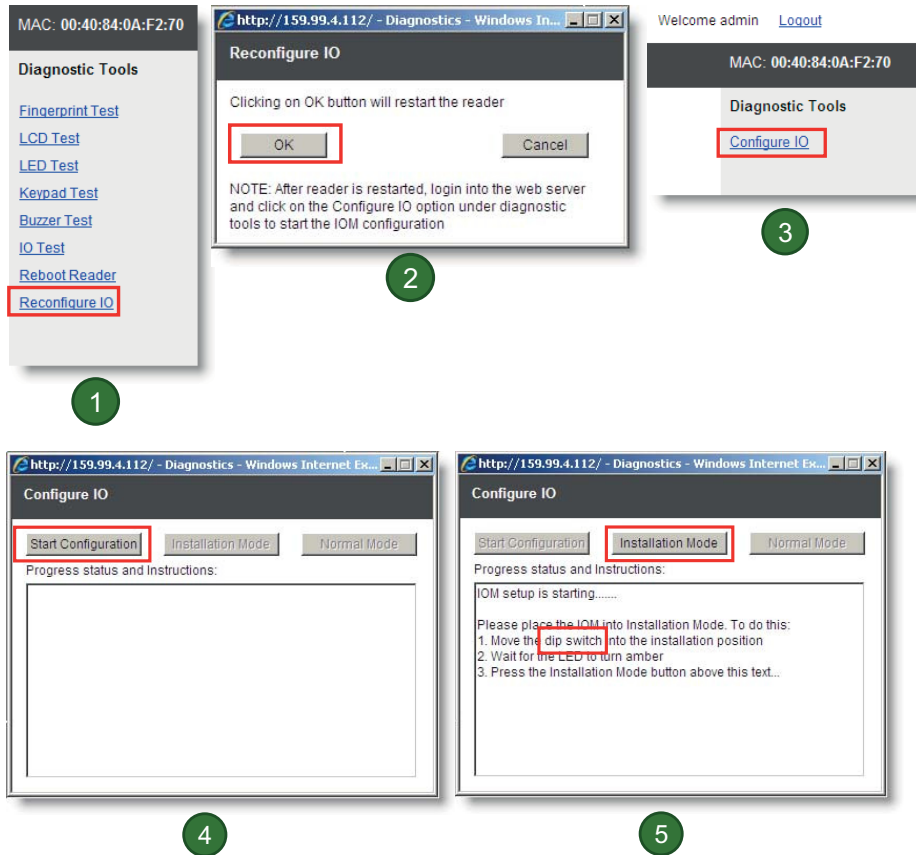

2. Position 8 of this switch is the IOM setup "dip switch.

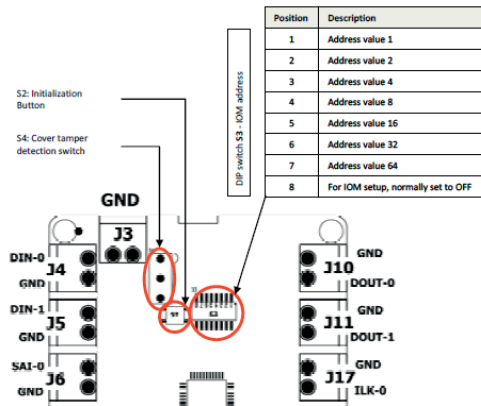

3. Slide it down as shown to turn it ON.

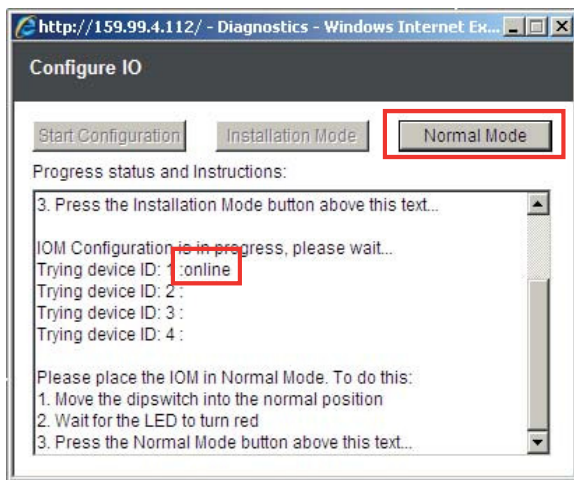
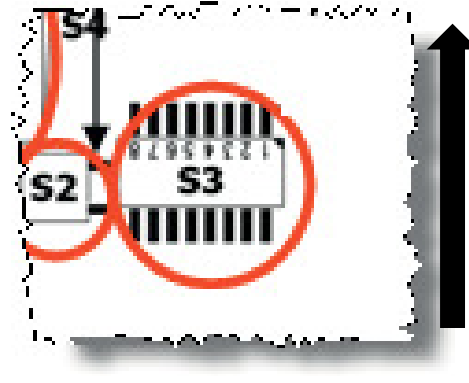
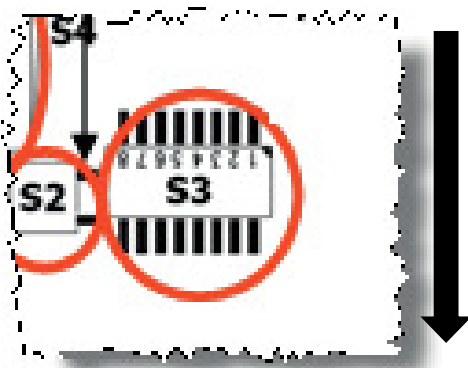

6

4. Slide switch up to put in normal position.

Door

1. Select the door IO addresses.
2. Enter door timings.
3. Enter door behavior.

Hint

— If common wiring & behavior it is quicker to do this from EBI later.

Testing the Door I/O

1. Select the Output Point and the desired level.
2. Select the Input Point to see its current value.

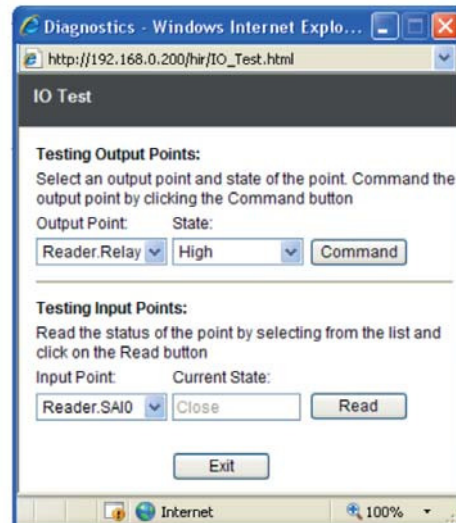

Testing the Network

1. Ping a well known IP Address.

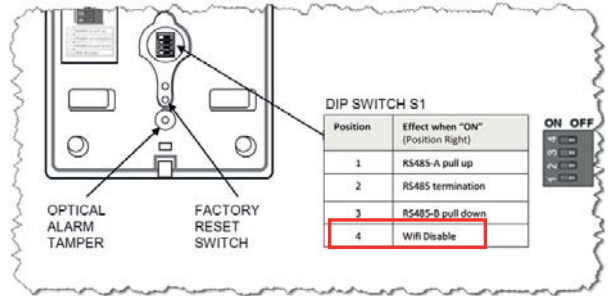
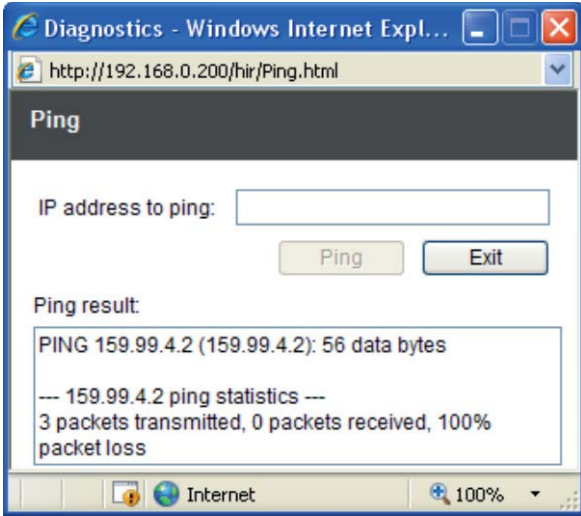

MAINTAINING THE IDENTIPOINT READERS

System health tests

All system health tests described in this section can be performed from the IdentIPoint device web pages. See *Configuring the Hardware* topic for details on accessing the same.

To perform fingerprint test:

1. Click Reader Information under Reader Profile. The reader information page is displayed.
2. Click Fingerprint Test from the Diagnostics and Tools list. The Finger Print Module Test page is displayed.
3. Click Test. A message Provide Your Finger Print appears on the LCD of the reader.
4. Present your fingerprint on the scanner. The reader scans the finger impression. A message Processing Completed appears on the LCD indicating the completion of the scanning process. While holding or swiping the finger should cover the IR sensor near to FP module other wise the reader functionality will not work.
5. A message Provide Your Finger Print Again appears on the LCD of the reader. Present your fingerprint on the scanner. The reader scans the finger impression. A message Processing Completed appears on the LCD indicating the completion of the scanning process.
6. If the fingerprint matches then a message Finger Print Matches appears on the reader LCD else a message Finger Print Mismatches appears.

To perform LCD test:

1. Click LCD Test from the Diagnostics and Tools list. The LCD Test page is displayed.
2. Type the message you want to convey in the Type Message here box.
3. Click Test. The typed text is displayed on the LCD of the reader.
4. Click Exit, to close the page.

To perform LED test

1. Click LED Test from the Diagnostics and Tools list. The LED Test page is displayed.
2. Click the appropriate option from the Observe the LED glowing.

Finishing

1. Logout of the webpage.

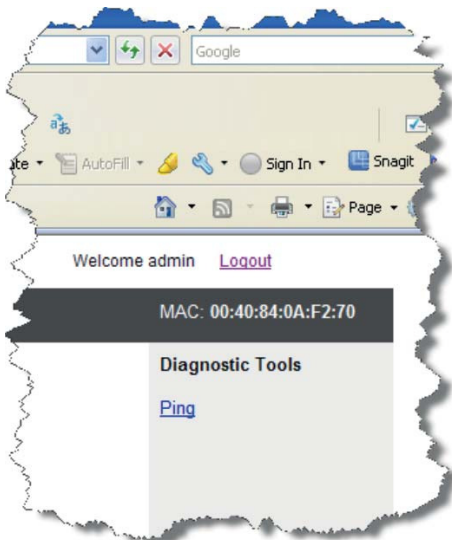

2. Present the card to the reader to disable wireless
3. If wireless will never again be used on this reader, it can be disabled in the hardware by setting bit 4 in the S1 DIP switch to ON (position left).

3. Click Test. The selected color blinks on the LED.
4. Click Exit. Exit from the LED test window.

To perform keypad test:

1. Click Keypad Test from the Diagnostics and Tools list. The Keypad Test window is displayed.
2. Click Test to initiate the test.
3. Type any 'num' keys on the keypad. The same text is displayed on the LCD of the reader.
4. Click Exit to close the page.

To perform IO test:

1. Click **IO Test** from the **Diagnostics and Tools** list, the IO Test page is displayed.
2. For testing the output points select an output point from the Output Point drop-down list.
 - a. Select a state from the State drop-down list.
 - b. Click **Command**, to set the command. The device connected to the respective output point is set to the appropriate selected state.
3. For testing the input points select an input point from the Input Point dropdown list.
 - a. Click **Read**, to read the input channel status.
 - b. The state of the device that is connected to the input point is displayed in the Current State text box.

To reboot the reader:

1. Click **Reboot Reader** from the **Diagnostics and Tools** list. The **Reboot Reader** page is displayed.
2. Click **Reboot**, reboots the card reader.

To check the IP:

NOTE: The availability of an IP address is checked on Ethernet and Wireless page.

1. Click Ping from the Diagnostics and Tools list on Ethernet or Wireless page. The Ping page is displayed.
2. Type the IP to be searched in IP address to ping text box.
3. Click Ping. The result is displayed on the Ping result window.

To perform a factory reset on the reader:

1. Keeping the reader powered on normally, remove it from the back-plate and find the factory reset switch at its back (see Fig.3).
2. Press the factory reset switch for 10 seconds or more until the reader LED/LCD is turned off.
3. When the LED/LCD is off, release the factory reset switch.
4. Wait for the reader to restart.
5. If using an LCD model, the **Honeywell** banner will appear on the display for a few seconds and then disappear.

6. Within 1 minute, the reader LED will start flashing green indicating that the reader has been reset to the factory firmware.
7. If using an LCD model with a DHCP server connected via Ethernet, the following will appear on the display within 1 minute:

**Honeywell
IdentIPoint
Version: 1.0.18.0**

aaa.bbb.ccc.ddd (where "aaa.bbb.ccc.ddd" is the IP address assigned by DHCP)

8. If using an LCD model WITHOUT a DHCP server connected via Ethernet, the following will appear on the display within 3 minutes:

**Honeywell
IdentIPoint
Version: 1.0.18.0
<blank>** (no IP address assigned)

NOTE: In case factory reset fails (which might happen if the factory reset switch is not released in time at step 3), the reader will beep multiple times while it is restarting. Afterwards it will not respond when a card is presented.

To recover from factory reset failure:

1. Power off the reader and power it on again.
2. Wait for the reader to start in normal mode.
3. Repeat all the required factory reset steps above.

LIGHTNING PROTECTION

Standard Lightning Protectors

If the Bus wiring enters or exits the building, the protector (s) listed in Table.13 must be used. Bus length must not exceed 3277 ft. (999 m). Refer to Honeywell Form No.95-7266 14502412 Lightning Protector Installation Instructions, and applicable local codes and standards for lightning protector installation.

Table 13. Lightning and Surge Protectors

Part Number	Description
14502412-011	120VAC Input Line
14502412-012	Low Voltage Input Line
14502412-014	Transmission Bus (RS485, F&S and Security Bus) Secondary Protection
14502412-020	Transmission Bus (RS-232 Bus) Secondary Protection
14507678-004	Ethernet Port Surge Protector

CERTIFICATIONS

READERS

- CE
- C-tick
- IP-65 (Basic Outdoor Version Only)

United States

- FCC 47 CFR Part 15, Subpart B, sections 107(a) & 109(a) Class B
- Section 201 to Section 205, section 207, section 209, section 215c, section 247 and section 35c

European Union

- EN 55022:2006; EN61000-3-2:2006
- EN 61000-6-3:2007
- EN 50130-4:1995+A1:1998+A2:2003
- EN 60950-1:2001
- EN 301 489-01 V1.6.1
- EN 301 489-03 V1.4.1
- EN 300 330-02 V1.3.1
- EN 50133-1:1997
- EN 50133-2-1:2000
- EN 50134-1:2000
- EN 50134-3:2001

Canada

- Canadian ICES-003 Class B

IOM

- CE
- C-tick

United States

- FCC 47 CFR Part 15, Subpart B, sections 107(a) & 109(a) Class B
- Section 201 to Section 202, section 207

European Union

- EN 55022:2006EN 60950-1:2001

Canada

- Canadian ICES-003 Class B

WARNING

Any changes or modifications not expressly approved by the party responsible for compliance could void the user's authority to operate the equipment.

This device complies with part 15 of the FCC Rules. Operation is subject to the following two conditions:

- This device may not cause harmful interference
- This device must accept any interference received, including interference that may cause undesired operation.

FCC Radiation Exposure Statement:

This equipment complies with FCC radiation exposure limits set forth for an uncontrolled environment. This equipment should be installed and operated with minimum distance of 20 cm between the radiator & your body.

Notice

This document contains Honeywell proprietary information. Information contained herein is to be used solely for the purpose submitted, and no part of this document or its contents shall be reproduced, published, or disclosed to a third party without the express permission of Honeywell International, Sarl.

While this information is presented in good faith and believed to be accurate, Honeywell disclaims all implied warranties, including, without limitation, the implied warranties of merchantability and fitness for a purpose, and makes no express warranties except as may be stated in its written agreement with and for its customer.

In no event is Honeywell liable to anyone for any indirect, incidental, special or consequential damages.

The information and specifications in this document are subject to change without notice.

Copyright © 2012 Honeywell International Inc.

Honeywell Trademarks

IdentIPoint™ is a registered trademark of Honeywell International Inc.

Other Trademarks

Microsoft and SQL Server are either registered trademarks or trademarks of Microsoft Corporation in the United States and/or other countries.

Trademarks that appear in this document are used only to the benefit of the trademark owner, with no intention of trademark infringement.

Support and other contacts

For technical assistance, call your nearest Honeywell office.

Feedback

Honeywell appreciates your comments about this manual. Please visit us on the web at www.honeywell.com/buildingsolutions to post your comments.

Automation and Control Solutions

Honeywell International Inc.

1985 Douglas Drive North

Golden Valley, MN 55422

www.honeywell.com/buildingsolutions

© U.S. Registered Trademark
© 2012 Honeywell International Inc.
95-7767 HSL, Rev. 05-12
Printed in U.S.A.

Honeywell