







# RADIO TEST REPORT

## Test Report No. 14263328S-B-R1

<b>Customer</b>	<b>SEIKO EPSON CORPORATION</b>
<b>Description of EUT</b>	<b>Printer</b>
<b>Model Number of EUT</b>	<b>M382C</b>
<b>FCC ID</b>	<b>BKMFBM382C</b>
<b>Test Regulation</b>	<b>FCC Part 15 Subpart E</b>
<b>Test Result</b>	<b>Complied (Refer to SECTION 3)</b>
<b>Issue Date</b>	<b>June 24, 2022</b>
<b>Remarks</b>	<b>WLAN (5 GHz band) part Except for DFS test</b>

<b>Representative Test Engineer</b>	<b>Approved By</b>
 Hiromasa Sato Engineer	 Kazutaka Takeyama Leader
 	
CERTIFICATE 1266.03	
<input type="checkbox"/> The testing in which "Non-accreditation" is displayed is outside the accreditation scopes in UL Japan, Inc.	
<input checked="" type="checkbox"/> There is no testing item of "Non-accreditation".	

Report Cover Page - Form-ULID-003532 (DCS:13-EM-F0429) Issue# 20.0

---

## **ANNOUNCEMENT**

- This test report shall not be reproduced in full or partial, without the written approval of UL Japan, Inc.
- The results in this report apply only to the sample tested.
- This sample tested is in compliance with the limits of the above regulation.
- The test results in this test report are traceable to the national or international standards.
- This test report must not be used by the customer to claim product certification, approval, or endorsement by the A2LA accreditation body.
- This test report covers Radio technical requirements.  
It does not cover administrative issues such as Manual or non-Radio test related Requirements. (if applicable)
- The all test items in this test report are conducted by UL Japan, Inc. Shonan EMC Lab.
- The opinions and the interpretations to the result of the description in this report are outside scopes where UL Japan, Inc. has been accredited.
- The information provided from the applicant for this report is identified in Section 1.
- For test report(s) referred in this report, the latest version (including any revisions) is always referred.

## **REVISION HISTORY**

### **Original Test Report No.: 14263328S-B**

This report is a revised version of 14263328S-B. 14263328S-B is replaced with this report.

Revision	Test Report No.	Date	Page Revised Contents
- (Original)	14263328S-B	June 2, 2022	-
R1	14263328S-B-R1	June 24, 2022	P.69 Correction of plot data title: From "5595 MHz" to "5795 MHz"

**Reference: Abbreviations (Including words undescribed in this report)**

A2LA	The American Association for Laboratory Accreditation	ICES	Interference-Causing Equipment Standard
AC	Alternating Current	IEC	International Electrotechnical Commission
AFH	Adaptive Frequency Hopping	IEEE	Institute of Electrical and Electronics Engineers
AM	Amplitude Modulation	IF	Intermediate Frequency
Amp, AMP	Amplifier	ILAC	International Laboratory Accreditation Conference
ANSI	American National Standards Institute	ISED	Innovation, Science and Economic Development Canada
Ant, ANT	Antenna	ISO	International Organization for Standardization
AP	Access Point	JAB	Japan Accreditation Board
ASK	Amplitude Shift Keying	LAN	Local Area Network
Atten., ATT	Attenuator	LIMS	Laboratory Information Management System
AV	Average	MCS	Modulation and Coding Scheme
BPSK	Binary Phase-Shift Keying	MRA	Mutual Recognition Arrangement
BR	Bluetooth Basic Rate	N/A	Not Applicable
BT	Bluetooth	NIST	National Institute of Standards and Technology
BT LE	Bluetooth Low Energy	NS	No signal detect.
BW	BandWidth	NSA	Normalized Site Attenuation
Cal Int	Calibration Interval	NVLAP	National Voluntary Laboratory Accreditation Program
CCK	Complementary Code Keying	OBW	Occupied Band Width
Ch., CH	Channel	OFDM	Orthogonal Frequency Division Multiplexing
CISPR	Comite International Special des Perturbations Radioelectriques	P/M	Power meter
CW	Continuous Wave	PCB	Printed Circuit Board
DBPSK	Differential BPSK	PER	Packet Error Rate
DC	Direct Current	PHY	Physical Layer
D-factor	Distance factor	PK	Peak
DFS	Dynamic Frequency Selection	PN	Pseudo random Noise
DQPSK	Differential QPSK	PRBS	Pseudo-Random Bit Sequence
DSSS	Direct Sequence Spread Spectrum	PSD	Power Spectral Density
EDR	Enhanced Data Rate	QAM	Quadrature Amplitude Modulation
EIRP, e.i.r.p.	Equivalent Isotropically Radiated Power	QP	Quasi-Peak
EMC	ElectroMagnetic Compatibility	QPSK	Quadri-Phase Shift Keying
EMI	ElectroMagnetic Interference	RBW	Resolution Band Width
EN	European Norm	RDS	Radio Data System
ERP, e.r.p.	Effective Radiated Power	RE	Radio Equipment
EU	European Union	RF	Radio Frequency
EUT	Equipment Under Test	RMS	Root Mean Square
Fac.	Factor	RSS	Radio Standards Specifications
FCC	Federal Communications Commission	Rx	Receiving
FHSS	Frequency Hopping Spread Spectrum	SA, S/A	Spectrum Analyzer
FM	Frequency Modulation	SG	Signal Generator
Freq.	Frequency	SVSWR	Site-Voltage Standing Wave Ratio
FSK	Frequency Shift Keying	TR	Test Receiver
GFSK	Gaussian Frequency-Shift Keying	Tx	Transmitting
GNSS	Global Navigation Satellite System	VBW	Video BandWidth
GPS	Global Positioning System	Vert.	Vertical
Hori.	Horizontal	WLAN	Wireless LAN

---

<b>CONTENTS</b>	<b>PAGE</b>
<b>SECTION 1: Customer Information</b> .....	<b>5</b>
<b>SECTION 2: Equipment Under Test (EUT)</b> .....	<b>5</b>
<b>SECTION 3: Test specification, Procedures &amp; Results</b> .....	<b>7</b>
<b>SECTION 4: Operation of EUT during testing</b> .....	<b>10</b>
<b>SECTION 5: Radiated Spurious Emission and Band Edge Compliance</b> .....	<b>13</b>
<b>SECTION 6: Antenna Terminal Conducted Tests</b> .....	<b>16</b>
<b>APPENDIX 1: Test Data</b> .....	<b>17</b>
26 dB Emission Bandwidth and 99 % Occupied Bandwidth.....	17
6 dB Bandwidth .....	36
Maximum Conducted Output Power .....	40
Maximum Power Spectral Density .....	54
Radiated Spurious Emission .....	71
Conducted Spurious Emission .....	116
<b>APPENDIX 2: Test Instruments</b> .....	<b>117</b>
<b>APPENDIX 3: Photographs of Test Setup</b> .....	<b>119</b>
Radiated Spurious Emission .....	119
Pre-check of Worst Case Position.....	120
Antenna Terminal Conducted Tests.....	121

## **SECTION 1: Customer Information**

Company Name	SEIKO EPSON CORPORATION
Address	80 Hirooka Harashinden, Shiojiri-shi, Nagano-ken 399-0705 Japan
Telephone Number	+81-263-52-2552
Contact Person	Takayuki Kuwahara

The information provided from the customer is as follows;

- Customer, Description of EUT, Model Number of EUT, FCC ID on the cover and other relevant pages
- Operating/Test Mode(s) (Mode(s)) on all the relevant pages
- SECTION 1: Customer Information
- SECTION 2: Equipment Under Test (EUT) other than the Receipt Date and Test Date
- SECTION 4: Operation of EUT during testing
- \* The laboratory is exempted from liability of any test results affected from the above information in SECTION 2 and 4.

## **SECTION 2: Equipment Under Test (EUT)**

### **2.1 Identification of EUT**

Description	Printer
Model Number	M382C
Serial Number	Refer to SECTION 4.2
Condition	Engineering prototype (Not for Sale: This sample is equivalent to mass-produced items.)
Modification	No Modification by the test lab
Receipt Date	March 14, 2022
Test Date	April 13 to May 24, 2022

### **2.2 Product Description**

#### **General Specification**

Rating	DC 7.2 V (Battery)
Operating temperature	-15 deg. C to +50 deg. C

**Radio Specification**

**WLAN (IEEE802.11b/11g/11n-20)**

Equipment Type	Transceiver
Frequency of Operation	2412 MHz to 2462 MHz
Type of Modulation	DSSS, OFDM
Antenna Type	PCB Printed Antenna
Antenna Gain	Ant1: 3.09 dBi, Ant2: 2.53 dBi

**WLAN (IEEE802.11a/11n-20/11ac-20/11n-40/11ac-40/11ac-80)**

Equipment Type	Transceiver	
Frequency of Operation	20 MHz Band:	5180 MHz to 5240 MHz 5260 MHz to 5320 MHz 5500 MHz to 5700 MHz 5745 MHz to 5825 MHz
	40 MHz Band:	5190 MHz to 5230 MHz 5270 MHz to 5310 MHz 5510 MHz to 5670 MHz 5755 MHz to 5795 MHz
	80 MHz Band:	5210 MHz 5290 MHz 5530 MHz 5775 MHz
Type of Modulation	DSSS, OFDM	
Antenna Type	PCB Printed Antenna	
Antenna Gain	5150 MHz to 5350 MHz:	Ant1: 5.94 dBi, Ant2: 3.94 dBi
	5470 MHz to 5725 MHz:	Ant1: 6.29 dBi, Ant2: 5.10 dBi
	5725 MHz to 5850 MHz:	Ant1: 7.12 dBi, Ant2: 5.23 dBi

### SECTION 3: Test specification, Procedures & Results

#### 3.1 Test Specification

Test Specification	FCC Part 15 Subpart E FCC Part 15 final revised on April 1, 2022 and effective May 2, 2022
Title	FCC 47 CFR Part 15 Radio Frequency Device Subpart E Unlicensed National Information Infrastructure Devices Section 15.407 General technical requirements

- \* The revision does not affect the test result conducted before its effective date.
- \* Also the EUT complies with FCC Part 15 Subpart B.

#### 3.2 Procedures and Results

Item	Test Procedure	Specification	Worst Margin	Results	Remarks
Conducted Emission	FCC: ANSI C63.10-2013 ISED: RSS-Gen 8.8	FCC: 15.407 (b) (6) / 15.207 ISED: RSS-Gen 8.8	-	N/A	*1)
26 dB Emission Bandwidth	FCC: KDB Publication Number 789033 ISED: -	FCC: 15.407 (a) (1) (2) (3) ISED: -	See data	Complied a)	Conducted
Maximum Conducted Output Power	FCC: KDB Publication Number 789033 ISED: -	FCC: 15.407 (a) (1) (2) (3) ISED: RSS-247 6.2.1.1 6.2.2.1 6.2.3.1 6.2.4.1		Complied b)	Conducted
Maximum Power Spectral Density	FCC: KDB Publication Number 789033 ISED: -	FCC : 15.407 (a) (1) (2) (3) ISED: RSS-247 6.2.1.1 6.2.2.1 6.2.3.1 6.2.4.1		Complied c)	Conducted
Spurious Emission Restricted Band Edge	FCC: ANSI C63.10-2013 KDB Publication Number 789033 ISED: -	FCC: 15.407 (b), 15.205 and 15.209 ISED: RSS-247 6.2.1.2 6.2.2.2 6.2.3.2 6.2.4.2	1.4 dB 5350.000 MHz, AV, Hori., Mode: Tx 11ac-40 5310 MHz	Complied# d) / e)	Conducted (< 30 MHz) / Radiated (> 30 MHz) *2)
6 dB Emission Bandwidth	FCC: ANSI C63.10-2013 ISED: -	FCC: 15.407 (e) ISED: RSS-247 6.2.4.1	See data	Complied f)	Conducted

Note: UL Japan, Inc.'s EMI Work Procedures: Work Instructions-ULID-003591 and Work Instructions-ULID-003593.

\* In case any questions arise about test procedure, ANSI C63.10: 2013 is also referred.

\*1) The test is not applicable since the radio function does not operate while connected to AC power line.

\*2) Radiated test was selected over 30 MHz based on FCC 15.407 (b) and KDB 789033 D02 G.3.b).

- a) Refer to APPENDIX 1 (data of 26 dB Emission Bandwidth and 99 % Occupied Bandwidth)
- b) Refer to APPENDIX 1 (data of Maximum Conducted Output Power)
- c) Refer to APPENDIX 1 (data of Maximum Power Spectral Density)
- d) Refer to APPENDIX 1 (data of Radiated Spurious Emission)
- e) Refer to APPENDIX 1 (data of Conducted Spurious Emission)
- f) Refer to APPENDIX 1 (data of 6 dB Bandwidth)

Symbols:

Complied The data of this test item has enough margin, more than the measurement uncertainty.

Complied# The data of this test item meets the limits unless the measurement uncertainty is taken into consideration

### **FCC Part 15.31 (e)**

This EUT provides the stable voltage constantly to RF Part regardless of input voltage. Therefore, this EUT complies with the requirement.

### **FCC Part 15.203 Antenna requirement**

It is impossible for end users to replace the antenna, because the antenna is mounted inside of the EUT. Therefore, the equipment complies with the antenna requirement of Section 15.203.

## **3.3 Addition to Standard**

Item	Test Procedure	Specification	Worst Margin	Results	Remarks
99 % Occupied Band Width	ISED: RSS-Gen 6.7	ISED: -	N/A	- a)	Conducted
a) Refer to APPENDIX 1 (data of 26 dB Emission Bandwidth and 99 % Occupied Bandwidth)					

Other than above, no addition, exclusion nor deviation has been made from the standard.

## **3.4 Uncertainty**

There is no applicable rule of uncertainty in this applied standard. Therefore, the following results are derived depending on whether or not laboratory uncertainty is applied.

The following uncertainties have been calculated to provide a confidence level of 95 % using a coverage factor  $k=2$ .  
Shonan EMC Lab.

Item	Frequency range	Uncertainty (+/-)		
		No. 1 SAC / SR	No. 2 SAC / SR	No. 3 SAC / SR
Radiated emission (Measurement distance: 3 m)	9 kHz-30 MHz	3.2 dB	3.1 dB	3.1 dB
	30 MHz-200 MHz	4.6 dB	4.6 dB	4.6 dB
	200 MHz-1 GHz	6.0 dB	6.1 dB	6.1 dB
	1 GHz-6 GHz	4.7 dB	4.7 dB	4.7 dB
	6 GHz-18 GHz	5.2 dB	5.3 dB	5.3 dB
	18 GHz-40 GHz	5.4 dB	5.5 dB	5.5 dB
Radiated emission (Measurement distance: 1 m)	1 GHz-18 GHz	5.6 dB	5.6 dB	5.6 dB
	18 GHz-40 GHz	5.8 dB	5.8 dB	5.8 dB

SAC=Semi-Anechoic Chamber

SR= Shielded Room is applied besides radiated emission

Antenna terminal test	Uncertainty (+/-)
Power Measurement above 1 GHz (Average Detector)_SPM-06	1.2 dB
Power Measurement above 1 GHz (Peak Detector)_SPM-06	2.0 dB
Power Measurement above 1 GHz (Average Detector)_SPM-07	1.2 dB
Power Measurement above 1 GHz (Peak Detector)_SPM-07	1.3 dB
Power Measurement above 1 GHz (Average Detector)_SPM-13	1.3 dB
Power Measurement above 1 GHz (Peak Detector)_SPM-13	1.3 dB
Spurious emission (Conducted) below 1 GHz	0.93 dB
Conducted emissions Power Density Measurement 1 GHz-3 GHz	0.92 dB
Conducted emissions Power Density Measurement 3 GHz-18 GHz	2.3 dB
Spurious emission (Conducted) 18 GHz-26.5 GHz	2.3 dB
Spurious emission (Conducted) 26.5 GHz-40 GHz	2.3 dB
Bandwidth Measurement	0.012 %
Duty cycle and Time Measurement	0.27 %
Temperature_SCH-01	0.93 deg.C.
Humidity_SCH-01	4.1 %
Temperature_SCH-02	2.0 deg.C.
Humidity_SCH-02	6.6 %
Voltage	0.97 %



### 3.5 Test Location

UL Japan, Inc. Shonan EMC Lab.

1-22-3, Megumigaoka, Hiratsuka-shi, Kanagawa-ken 259-1220 JAPAN

Telephone: +81 463 50 6400, Facsimile: +81 463 50 6401

A2LA Certificate Number: 1266.03

(FCC test firm registration number: 626366, ISED lab company number: 2973D / CAB identifier: JP0001)

Test site	IC Registration Number	Width x Depth x Height (m)	Size of reference ground plane (m) / horizontal conducting plane	Maximum measurement distance
No.1 Semi-anechoic chamber	2973D-1	20.6 x 11.3 x 7.65	20.6 x 11.3	10 m
No.2 Semi-anechoic chamber	2973D-2	20.6 x 11.3 x 7.65	20.6 x 11.3	10 m
No.3 Semi-anechoic chamber	2973D-3	12.7 x 7.7 x 5.35	12.7 x 7.7	5 m
No.4 Semi-anechoic chamber	-	8.1 x 5.1 x 3.55	8.1 x 5.1	-
No.1 Shielded room	-	6.8 x 4.1 x 2.7	6.8 x 4.1	-
No.2 Shielded room	-	6.8 x 4.1 x 2.7	6.8 x 4.1	-
No.3 Shielded room	-	6.3 x 4.7 x 2.7	6.3 x 4.7	-
No.4 Shielded room	-	4.4 x 4.7 x 2.7	4.4 x 4.7	-
No.5 Shielded room	-	7.8 x 6.4 x 2.7	7.8 x 6.4	-
No.6 Shielded room	-	7.8 x 6.4 x 2.7	7.8 x 6.4	-
No.8 Shielded room	-	3.45 x 5.5 x 2.4	3.45 x 5.5	-
No.1 Measurement room	-	2.55 x 4.1 x 2.5	-	-

### 3.6 Test Data, Test Instruments, and Test Set Up

Refer to APPENDIX.

## **SECTION 4: Operation of EUT during testing**

### **4.1 Operating Mode(s)**

Test operating mode was determined as follows according to “Section 1 of 6 802.11 a/b/g/n testing - Managing Complex Regulatory Approvals -” of TCB Council Workshop October 2009 and also was judged the necessity of 802.11ac mode by the pre-test.

<b>Mode</b>	<b>Remarks*</b>
IEEE 802.11a (11a)	36 Mbps, PN9
IEEE 802.11n 20 MHz BW (11n-20)	MCS 4, PN9
IEEE 802.11ac 20 MHz BW (11ac-20)	MCS 6, PN9
IEEE 802.11n 40 MHz BW (11n-40)	MCS 1, PN9
IEEE 802.11ac 40 MHz BW (11ac-40)	MCS 4, PN9
IEEE 802.11ac 80 MHz BW (11ac-80)	MCS 9, PN9
*Transmitting duty was 100 % on all tests.	
*The worst condition was determined based on the test result of Maximum Conducted Output Power.	
*Power of the EUT was set by the software as follows;	
Power	11a: 5180 MHz to 5320 MHz: 36 (Setting Value)
Setting:	5500 MHz to 5700 MHz: 38 (Setting Value)
	5745 MHz to 5825 MHz: 40 (Setting Value)
	11n-20: 5180 MHz to 5320 MHz: 33 (Setting Value)
	5500 MHz to 5700 MHz: 34 (Setting Value)
	5745 MHz to 5825 MHz: 36 (Setting Value)
	11ac-20: 36 (Setting Value)
	11n-40: 5190 MHz to 5310 MHz: 34 (Setting Value)
	5510 MHz to 5795 MHz: 36 (Setting Value)
	11ac-40: 5190 MHz to 5310 MHz: 34 (Setting Value)
	5150 MHz to 5670 MHz: 35 (Setting Value)
	5755 MHz, 5795 MHz: 36 (Setting Value)
	11ac-80: 5210 MHz, 5290 MHz: 30 (Setting Value)
	5530 MHz to 5775 MHz: 36 (Setting Value)
Software:	Realtek 11ac 8821C USB WLAN MP Diagnostic Program Version: 0.0003.01. (Date: 2022.03 14, Storage location: Driven by connected PC)
*This setting of software is the worst case.	
Any conditions under the normal use do not exceed the condition of setting.	
In addition, end users cannot change the settings of the output power of the product.	

\*The Details of Operation Mode(s)

Test Item	Operating Mode	Tested Antenna *2)	Tested Frequency			
			Lower Band	Middle Band	Additional Band	Upper Band
26 dB Emission Bandwidth	Tx 11a Tx 11n-20 Tx 11ac-20	1	-	5260 MHz 5300 MHz 5320 MHz	5500 MHz 5580 MHz 5700 MHz	-
	Tx 11n-40 Tx 11ac-40	1	-	5270 MHz 5310 MHz	5510 MHz 5550 MHz 5670 MHz	-
	Tx 11ac-80	1	-	5290 MHz	5530 MHz	-
99 % Occupied Bandwidth, Maximum Conducted Output Power, Maximum Power Spectral Density	Tx 11a Tx 11n-20 Tx 11ac-20	1	5180 MHz 5200 MHz 5240 MHz	5260 MHz 5300 MHz 5320 MHz	5500 MHz 5580 MHz 5700 MHz	5745 MHz 5785 MHz 5825 MHz
	Tx 11n-40 Tx 11ac-40	1	5190 MHz 5230 MHz	5270 MHz 5310 MHz	5510 MHz 5550 MHz 5670 MHz	5755 MHz 5795 MHz
	Tx 11ac-80	1	5210 MHz	5290 MHz	5530 MHz	5775 MHz
	Tx 11a Tx 11n-20 Tx 11ac-20	1	-	-	-	5745 MHz 5785 MHz 5825 MHz
	Tx 11n-40 Tx 11ac-40	1	-	-	-	5755 MHz 5795 MHz
Radiated Spurious Emission*5) (Below 1 GHz), Conducted Spurious Emission	Tx 11a *1)	1	-	-	-	5745 MHz
	Tx 11a Tx 11ac-20 *3) Tx 11ac-40 *4) Tx 11ac-80	1 1 1	5180 MHz 5190 MHz 5210 MHz	5320 MHz 5310 MHz 5290 MHz	5500 MHz 5700 MHz 5510 MHz 5670 MHz 5530MHz	5745 MHz 5825 MHz 5755 MHz 5795 MHz 5775 MHz

\*1) The mode was tested as a representative, because it had the highest power at antenna terminal test.  
\*2) As a result of pre-check in Radiated Emission, The test was performed with the antenna that had higher power as a representative.  
\*3) Tx 11n-20 mode was excluded by using 11ac-20 mode as a representative.  
\*4) Tx 11n-40 mode was excluded by using 11ac-40 mode as a representative.  
\*5) Test for spot check was performed on below mode.  
Radiated Spurious Emission (Below 1 GHz): Tx 11a 5745 MHz  
Radiated Spurious Emission (Above 1 GHz):  
Tx 11a/ac-20 (5180 MHz / 5320 MHz / 5500 MHz / 5700 MHz / 5745 MHz / 5825 MHz) (Band Edge Compliance)  
Tx 11ac-40 (5190 MHz / 5310 MHz / 5510 MHz / 5670 MHz / 5755 MHz / 5795 MHz) (Band Edge Compliance)  
Tx 11ac-80 (5210 MHz / 5290 MHz / 5530 MHz / 5775 MHz) (Band Edge Compliance)  
Tx 11a 5745 MHz (Other Spurious Emission)

## Configuration and Peripherals

<For Radiated Emission test>

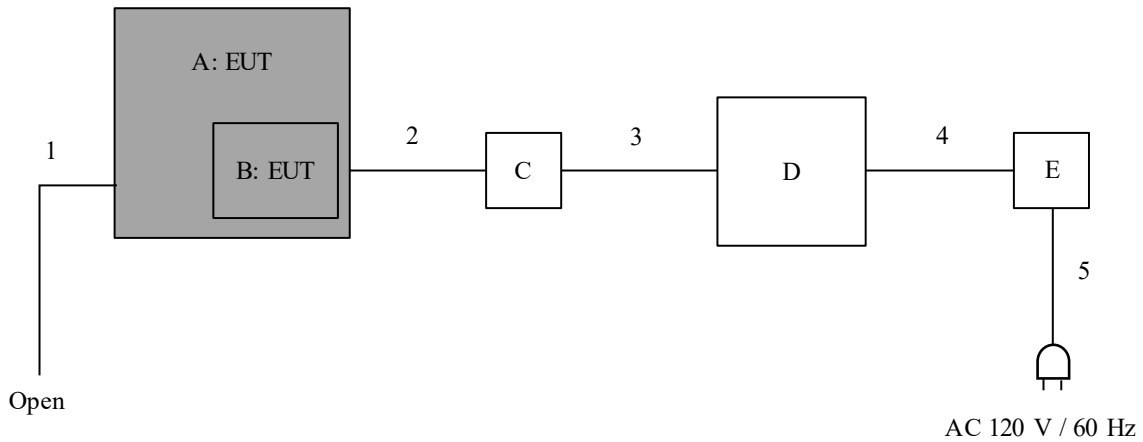

\* Cabling and setup(s) were taken into consideration and test data was taken under worse case conditions.

<For Antenna Terminal Conducted test>

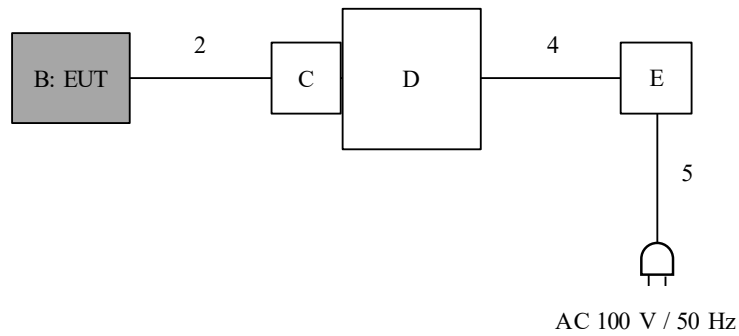

### Description of EUT and Support Equipment

No.	Item	Model number	Serial Number	Manufacturer	Remarks
A	Printer	M382C	EQAF000014	SEIKO EPSON CORPORATION	EUT
B	11ac + BT Combo module	J26H005	221805500 E0AA14747	Foxconn	EUT
C	Test board	-	-	Foxconn	-
D	Laptop Computer	7666-77J	LV-B8PZ8 08/05	Lenovo	-
E	AC Adapter	92P1213	11S92P1213Z1ZD DZ92C2WU	Lenovo	-

### List of Cables Used

No.	Name	Length (m)	Shield		Remarks
			Cable	Connector	
1	USB	1.0	Shielded	Shielded	-
2	Signal	0.5	Unshielded	Unshielded	-
3	USB	2.0	Shielded	Shielded	-
4	DC	1.8	Unshielded	Unshielded	-
5	AC	0.9	Unshielded	Unshielded	-

---

## **SECTION 5: Radiated Spurious Emission and Band Edge Compliance**

### **Test Procedure**

< Below 1GHz >

EUT was placed on a urethane platform of nominal size, 1.0 m by 1.5 m, raised 0.8 m above the conducting ground plane. The Radiated Electric Field Strength has been measured in a Semi Anechoic Chamber with a ground plane.

< Above 1GHz >

EUT was placed on a urethane platform of nominal size, 0.5 m by 0.5 m, raised 1.5 m above the conducting ground plane.

The Radiated Electric Field Strength has been measured in a Semi Anechoic Chamber with absorbent materials lined on a ground plane.

The height of the measuring antenna varied between 1 m and 4 m and EUT was rotated a full revolution in order to obtain the maximum value of the electric field strength.

Test antenna was aimed at the EUT for receiving the maximum signal and always kept within the illumination area of the 3 dB beamwidth of the antenna. (Above 1 GHz)

The measurements were performed for both vertical and horizontal antenna polarization with the Test Receiver, or the Spectrum Analyzer.

The measurements were made with the following detector function of the test receiver and the Spectrum analyzer (in linear mode).

The test was made with the detector (RBW/VBW) in the following table.

When using Spectrum analyzer, the test was made with adjusting span to zero by using peak hold.

< Below 1GHz >

The result also satisfied with the general limits specified in section 15.209 (a).

< Above 1GHz >

Inside of restricted bands (Section 15.205):

Apply to limit in the Section 15.209 (a).

Outside of the restricted bands:

Apply to limit 68.2 dBuV/m, 3 m (-27 dBm e.i.r.p.\* ) in the Section 15.407 (b) (1) (2) (3).

For U-NII-3 Bandedge

-27 dBm/MHz at 75 MHz or more above or below the band edge increasing linearly to 10 dBm/MHz at 25 MHz above or below the band edge, and from 25 MHz above or below the band edge increasing linearly to a level of 15.6 dBm/MHz at 5 MHz above or below the band edge, and from 5 MHz above or below the band edge increasing linearly to a level of 27 dBm/MHz at the band edge in the section 15.407(b)(4)(i).

Restricted band edge:

Apply to limit in the Section 15.209 (a).

Since this limit is severer than the limit of the inside of restricted bands.

\*Electric field strength to e.i.r.p. conversion:

$$E = \frac{1000000 \sqrt{30 P}}{3} \text{ (uV/m)} \quad :P \text{ is the e.i.r.p. (Watts)}$$

**Test Antennas are used as below;**

Frequency	30 MHz to 200 MHz	200 MHz to 1 GHz	Above 1 GHz
Antenna Type	Biconical	Logperiodic	Horn

Frequency	Below 1 GHz	Above 1 GHz	
Instrument Used	Test Receiver	Spectrum Analyzer	
Detector	QP	Peak	Average
IF Bandwidth	BW: 120 kHz	RBW: 1 MHz VBW: 3 MHz	Method VB *1) RBW: 1 MHz VBW: 1/T MHz (T: Burst length, refer to the Burst rate confirmation.) Detector: Peak Trace mode: Max hold

\*1) The test method was also referred to KDB 789033 D02 General UNII Test Procedures New Rules v02r01 "Guidelines for Compliance Testing of Unlicensed National Information Infrastructure (U-NII) Devices Part 15, Subpart E".

**Figure 2: Test Setup**

Below 1 GHz

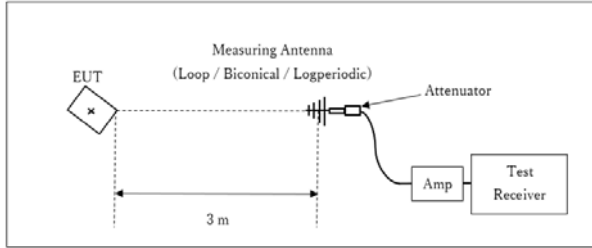

× : Center of turn table

Test Distance: 3 m

1 GHz to 10 GHz

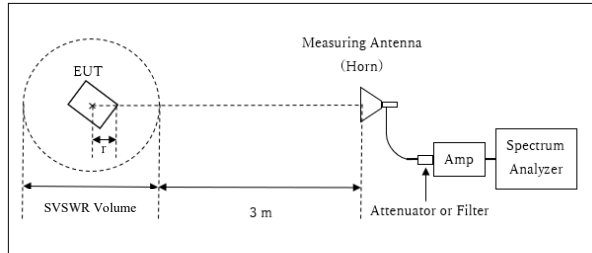

r : Radius of an outer periphery of EUT  
× : Center of turn table

Distance Factor:  $20 \times \log(3.95 \text{ m} / 3.0 \text{ m}) = 2.38 \text{ dB}$   
\* Test Distance:  $(3 + \text{SVSWR Volume} / 2) - r = 3.95 \text{ m}$

SVSWR Volume : 2.0 m  
(SVSWR Volume has been calibrated based on CISPR 16-1-4.)  
 $r = 0.05 \text{ m}$

10 GHz to 40 GHz

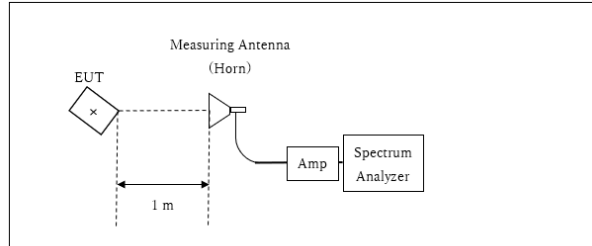

× : Center of turn table

Distance Factor:  $20 \times \log(1.0 \text{ m} / 3.0 \text{ m}) = -9.54 \text{ dB}$   
\*Test Distance: 1 m

- The carrier level and noise levels were confirmed at each position of X, Y and Z axes of EUT to see the position of maximum noise, and the test was made at the position that has the maximum noise.

Antenna polarization	Carrier	Spurious (30 MHz - 1 GHz)	Spurious (1 GHz - 2.8 GHz)	Spurious (2.8 GHz - 10 GHz)	Spurious (10 GHz - 18 GHz)	Spurious (18 GHz - 26.5 GHz)	Spurious (26.5 GHz - 40 GHz)
Horizontal	Z	Z	Z	Z	X	X	X
Vertical	X	Z	X	Y	X	X	X

The test results and limit are rounded off to one decimal place, so some differences might be observed.

**Measurement Range** : 30 MHz to 40 GHz  
**Test Data** : APPENDIX  
**Test Result** : Pass

## **SECTION 6: Antenna Terminal Conducted Tests**

### **Test Procedure**

The tests were made with below setting connected to the antenna port.

Test	Span	RBW	VBW	Sweep time	Detector	Trace	Instrument used and Test method
26 dB Bandwidth	Enough to capture the emission	Close to 1 % of EBW	> RBW	Auto	Peak	Max Hold	Spectrum Analyzer
99 % Occupied Bandwidth *1)	Enough width to display emission skirts	1 % to 5 % of OBW	≥ 3 RBW	Auto	Peak	Max Hold	Spectrum Analyzer
6 dB Bandwidth	Enough to capture the emission	100 kHz	300 kHz	Auto	Peak	Max Hold	Spectrum Analyzer
Maximum Conducted Output Power	-	-	-	Auto	Average	-	Power Meter (Sensor: 160 MHz BW) (Method PM)
Maximum Power Spectral Density	Encompass the entire EBW	1 MHz or 100 kHz *2)	≥ 3 RBW	Auto	RMS Power Averaging (100 times)	Clear Write	Spectrum Analyzer
Conducted Spurious Emission*3) *4)	9 kHz to 150 kHz 150 kHz to 30 MHz	200 Hz 10 kHz	620 Hz 30 kHz	Auto	Peak	Max Hold	Spectrum Analyzer

\* The test method was also referred to KDB 789033 D02 General UNII Test Procedures New Rules v02r01 "Guidelines for Compliance Testing of Unlicensed National Information Infrastructure (U-NII) Devices Part 15, Subpart E".

\*1) Peak hold was applied as Worst-case measurement.

\*2) KDB 789033 D02 says that RBW is set to be 500 kHz for 5.725 GHz to 5.850 GHz, but it is not possible with spectrum analyzer, so RBW Correction Factor ( $10 \log(500 \text{ kHz} / 100 \text{ kHz})$ ) was added to the test result.

\*3) In the frequency range below 30 MHz, RBW was narrowed to separate the noise contents.

Then, wide-band noise near the limit was checked separately, however the noise was not detected as shown in the chart. (9 kHz to 150 kHz: RBW = 200 Hz, 150 kHz to 30 MHz: RBW = 10 kHz)

\*4) The limits in CFR 47, Part 15, Subpart C, paragraph 15.209(a), are identical to those in RSS-Gen section 8.9, Table 6, since the measurements are performed in terms of magnetic field strength and converted to electric field strength levels (as reported in the table) using the free space impedance of 377 Ohms. For example, the measurement at frequency 9 kHz resulted in a level of 45.5 dBuV/m, which is equivalent to  $45.5 - 51.5 = -6.0$  dBuA/m, which has the same margin, 3 dB, to the corresponding RSS-Gen Table 6 limit as it has to 15.209(a) limit.

The test results and limit are rounded off to two decimals place, so some differences might be observed. The equipment and cables were not used for factor 0 dB of the data sheets.

**Test Data** : APPENDIX  
**Test Result** : Pass



## APPENDIX 1: Test Data

### 26 dB Emission Bandwidth and 99 % Occupied Bandwidth

Test place	Shonan EMC Lab. No.5 Shielded Room	
Date	May 20, 2022	May 24, 2022
Temperature / Humidity	24 deg. C / 40 % RH	25 deg. C / 46 % RH
Engineer	Hiromasa Sato	Shiro Kobayashi
Mode	Tx	

11a

Tested Frequency [MHz]	26 dB Emission Bandwidth [MHz]	99 % Occupied Bandwidth [kHz]
5180	-	16817.7
5200	-	16835.1
5240	-	16852.7
5260	19.775	16824.4
5300	19.825	16828.1
5320	19.852	16840.7
5500	19.649	16818.4
5580	19.680	16832.9
5700	19.721	16833.1
5745	-	16809.7
5785	-	16819.5
5825	-	16826.9

11n-20

Tested Frequency [MHz]	26 dB Emission Bandwidth [MHz]	99 % Occupied Bandwidth [kHz]
5180	-	17859.8
5200	-	17830.1
5240	-	17804.4
5260	20.913	17815.3
5300	20.901	17866.6
5320	20.804	17866.6
5500	20.540	17804.3
5580	20.539	17835.8
5700	20.757	17816.9
5745	-	17822.3
5785	-	17866.9
5825	-	17845.0

11ac-20

Tested Frequency [MHz]	26 dB Emission Bandwidth [MHz]	99 % Occupied Bandwidth [kHz]
5180	-	17837.1
5200	-	17839.6
5240	-	17857.8
5260	20.947	17834.0
5300	20.983	17839.9
5320	20.946	17838.7
5500	20.830	17826.1
5580	20.828	17830.3
5700	20.848	17827.3
5745	-	17821.2
5785	-	17820.5
5825	-	17818.5

## 26 dB Emission Bandwidth and 99 % Occupied Bandwidth

Test place	Shonan EMC Lab. No.5 Shielded Room	
Date	May 20, 2022	May 24, 2022
Temperature / Humidity	24 deg. C / 40 % RH	25 deg. C / 46 % RH
Engineer	Hiomasa Sato	Shiro Kobayashi
Mode	Tx	

### 11n-40

Tested Frequency [MHz]	26 dB Emission Bandwidth [MHz]	99 % Occupied Bandwidth [kHz]
5190	-	36176.4
5230	-	36257.4
5270	40.414	36278.7
5310	40.511	36283.3
5510	40.287	36145.0
5550	39.586	36216.8
5670	39.789	36209.2
5755	-	36282.0
5795	-	36248.9

### 11ac-40

Tested Frequency [MHz]	26 dB Emission Bandwidth [MHz]	99 % Occupied Bandwidth [kHz]
5190	-	36322.3
5230	-	36371.1
5270	40.883	36339.7
5310	40.855	36331.1
5510	40.919	36307.1
5550	40.934	36317.6
5670	40.758	36299.9
5755	-	36307.6
5795	-	36305.0

### 11ac-80

Tested Frequency [MHz]	26 dB Emission Bandwidth [MHz]	99 % Occupied Bandwidth [kHz]
5210	-	75757.8
5290	80.876	75729.7
5530	80.892	75799.6
5775	-	75791.6

**26 dB Emission Bandwidth**

11a

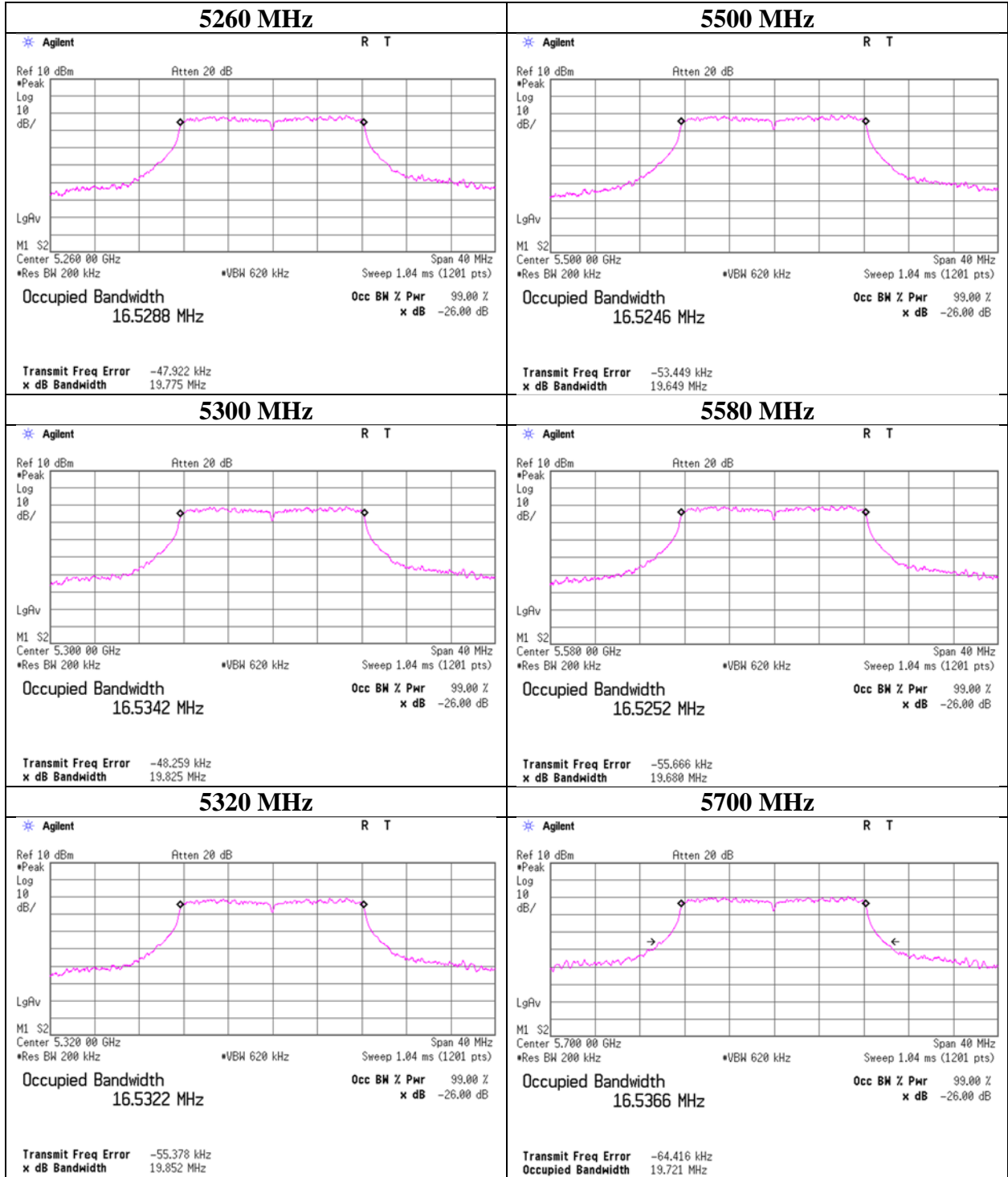

### 26 dB Emission Bandwidth

11n-20

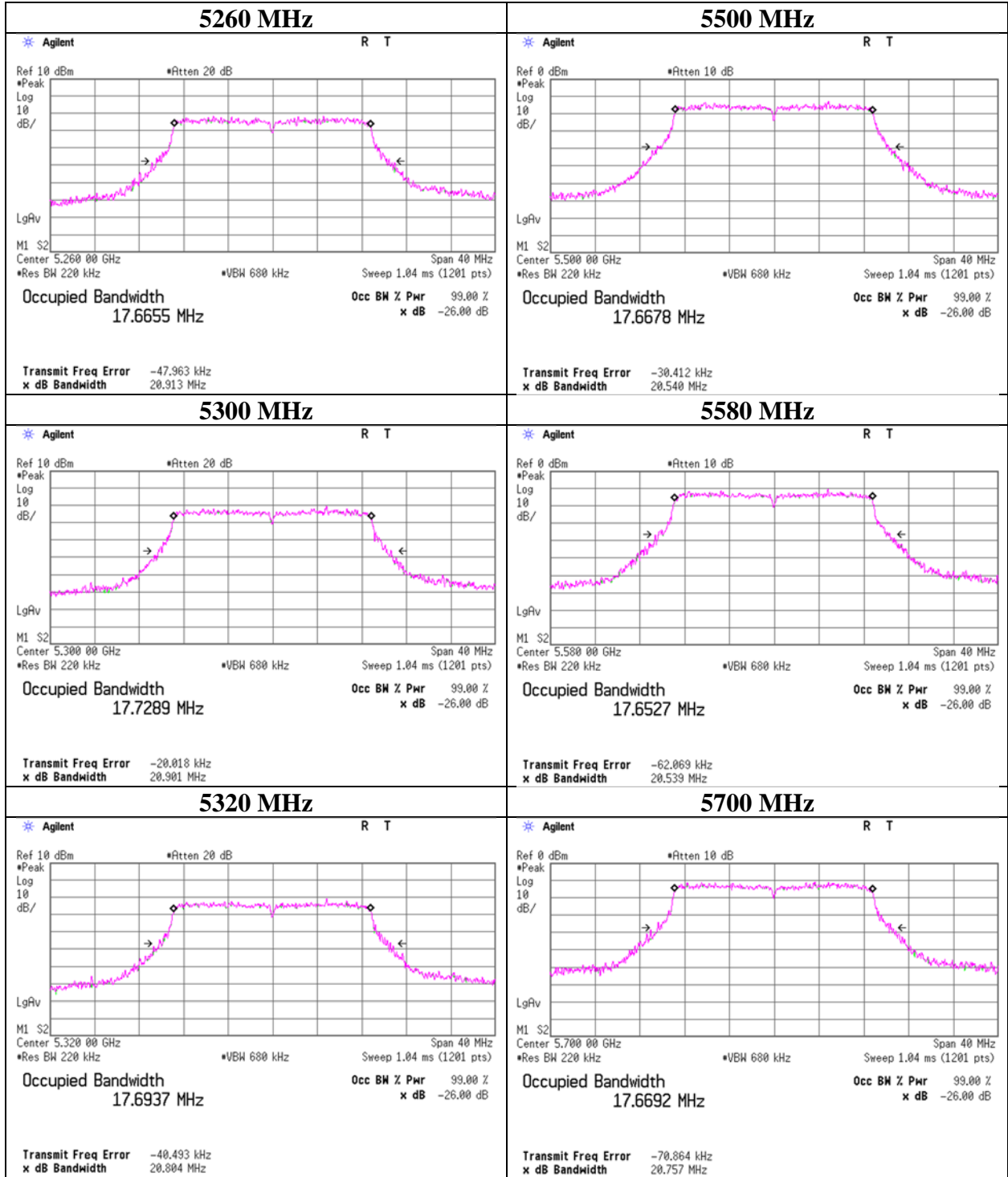

**26 dB Emission Bandwidth**

**11ac-20**

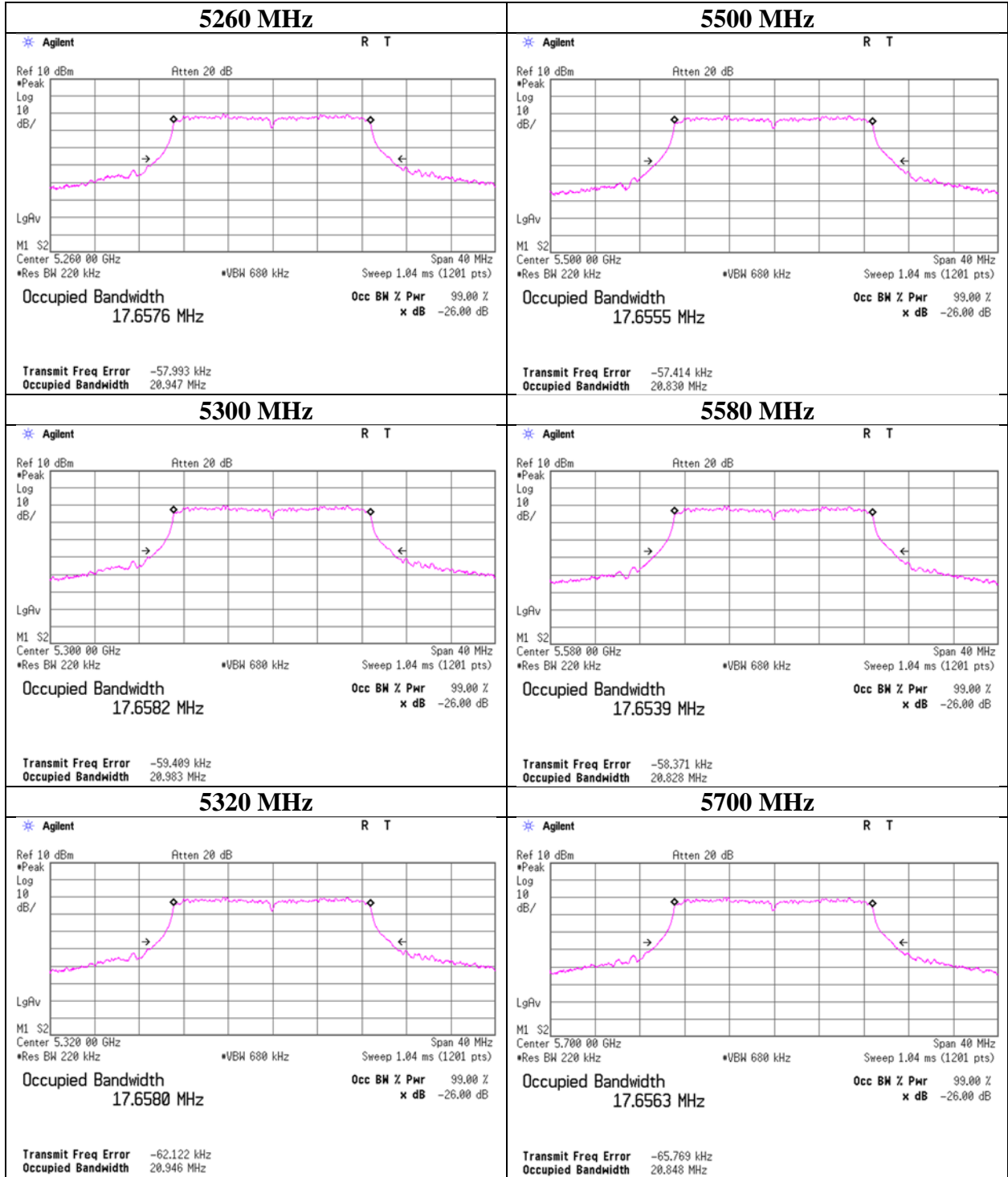

### 26 dB Emission Bandwidth

11n-40

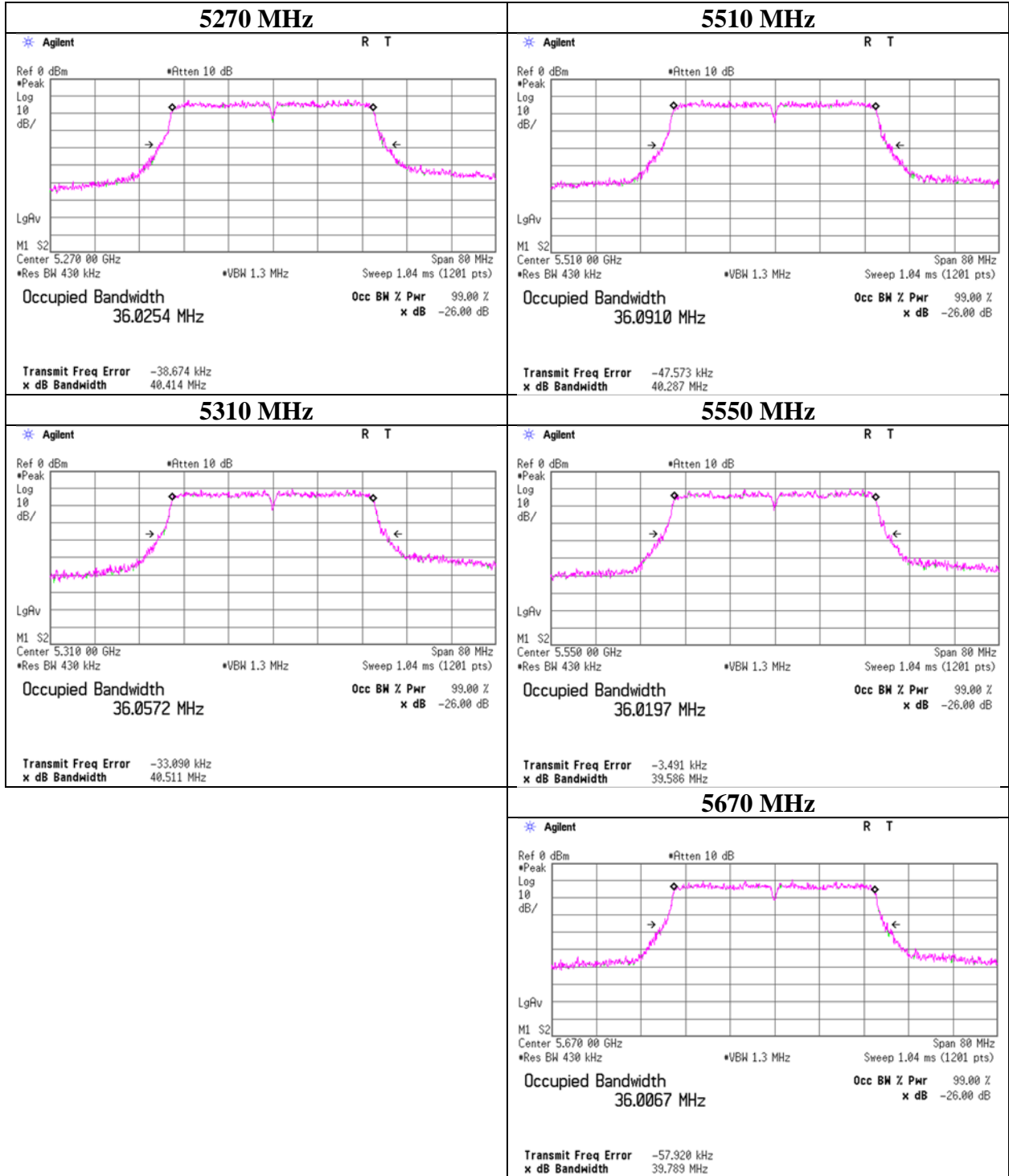

### 26 dB Emission Bandwidth

#### 11ac-40

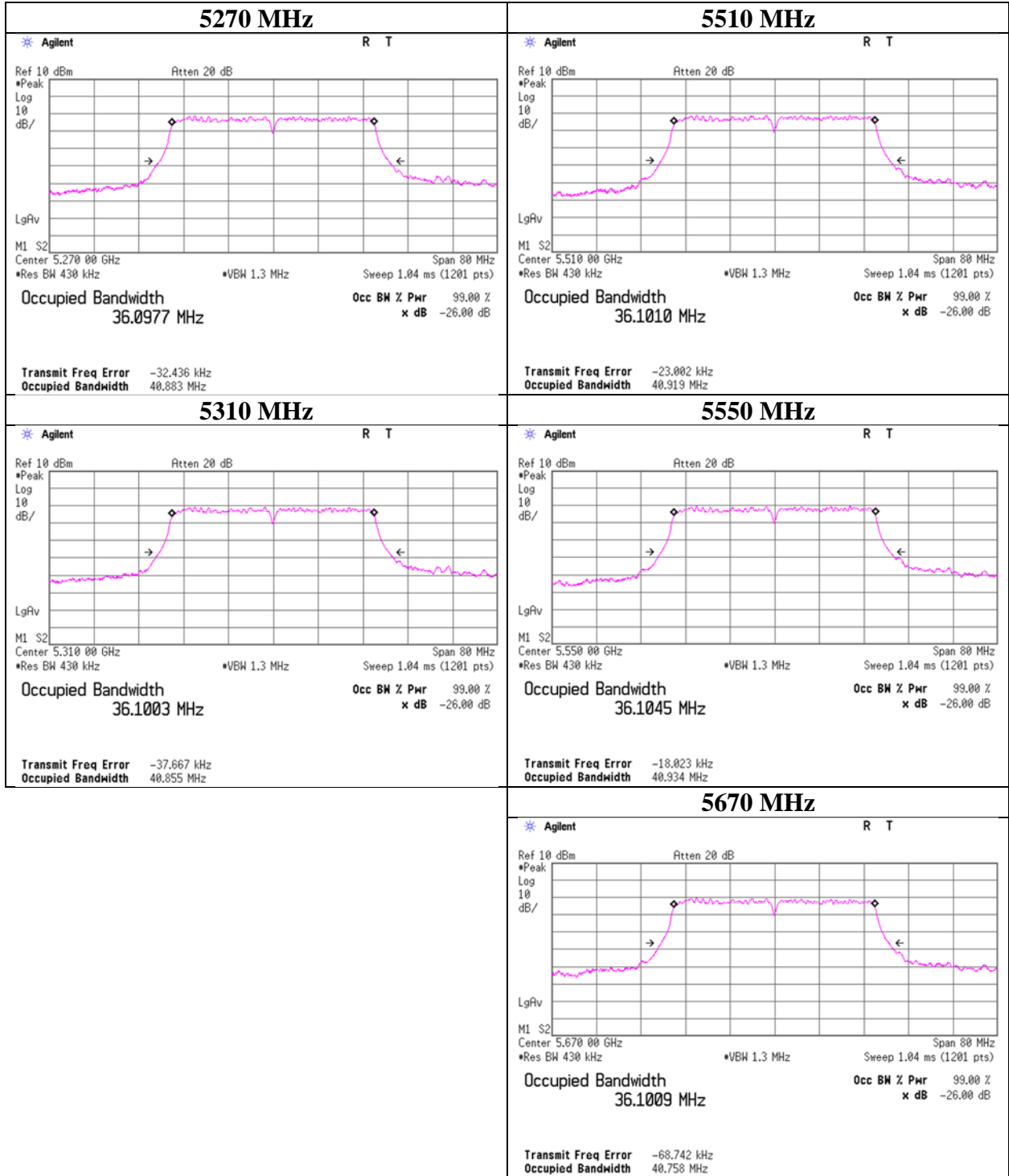

## 26 dB Emission Bandwidth

11ac-80

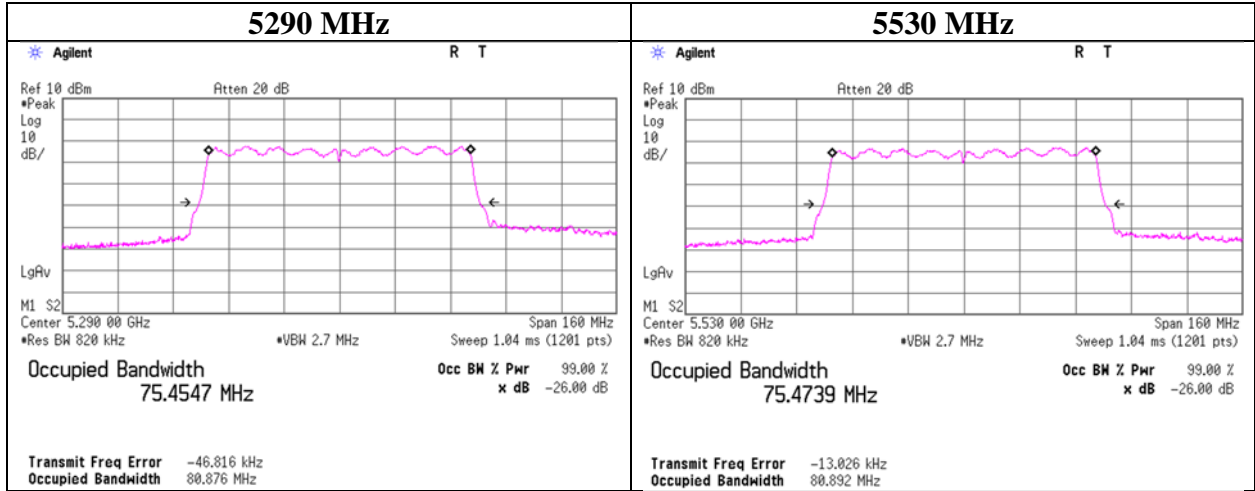



### 99 % Occupied Bandwidth

11a

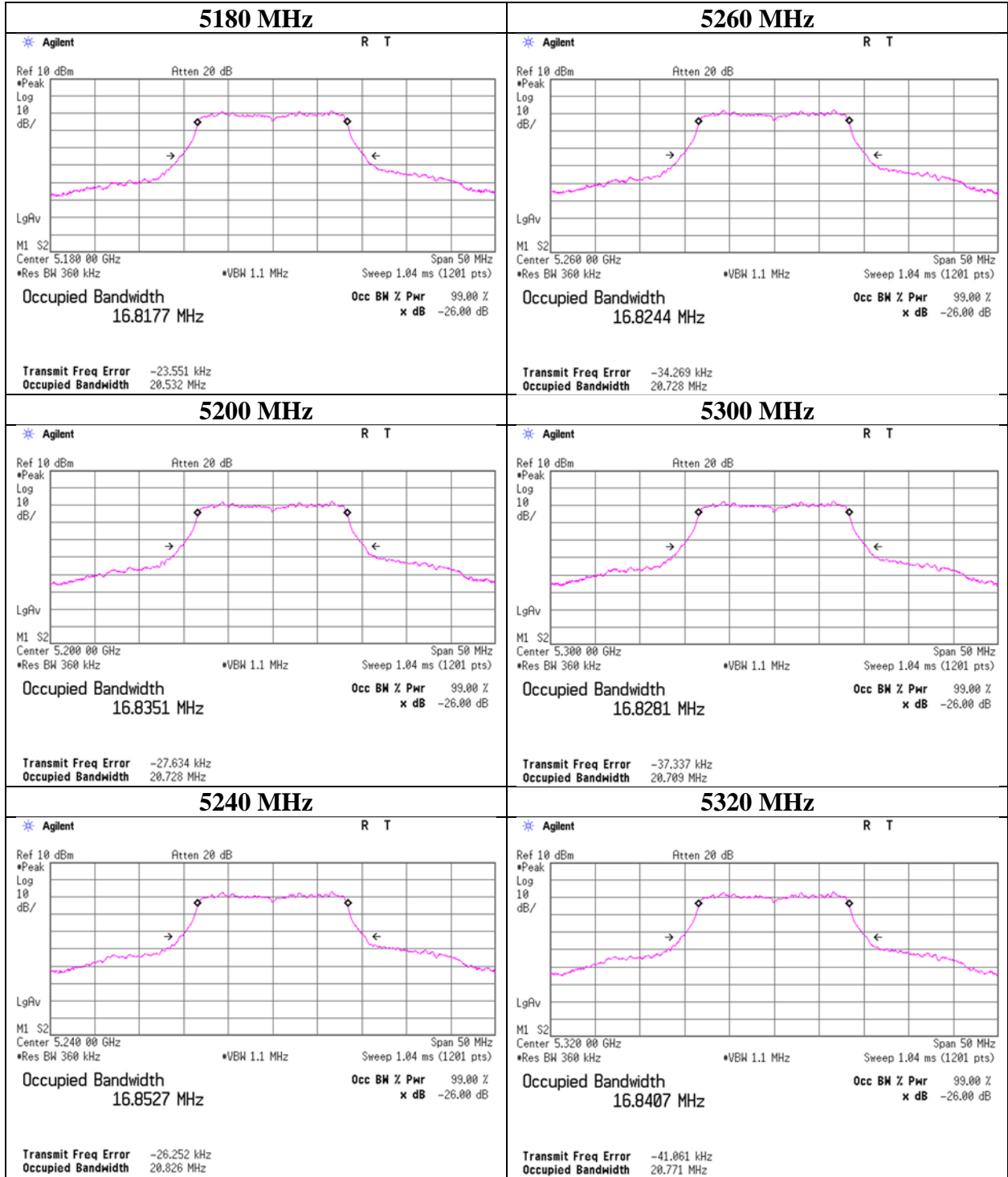

**99 % Occupied Bandwidth**

11a

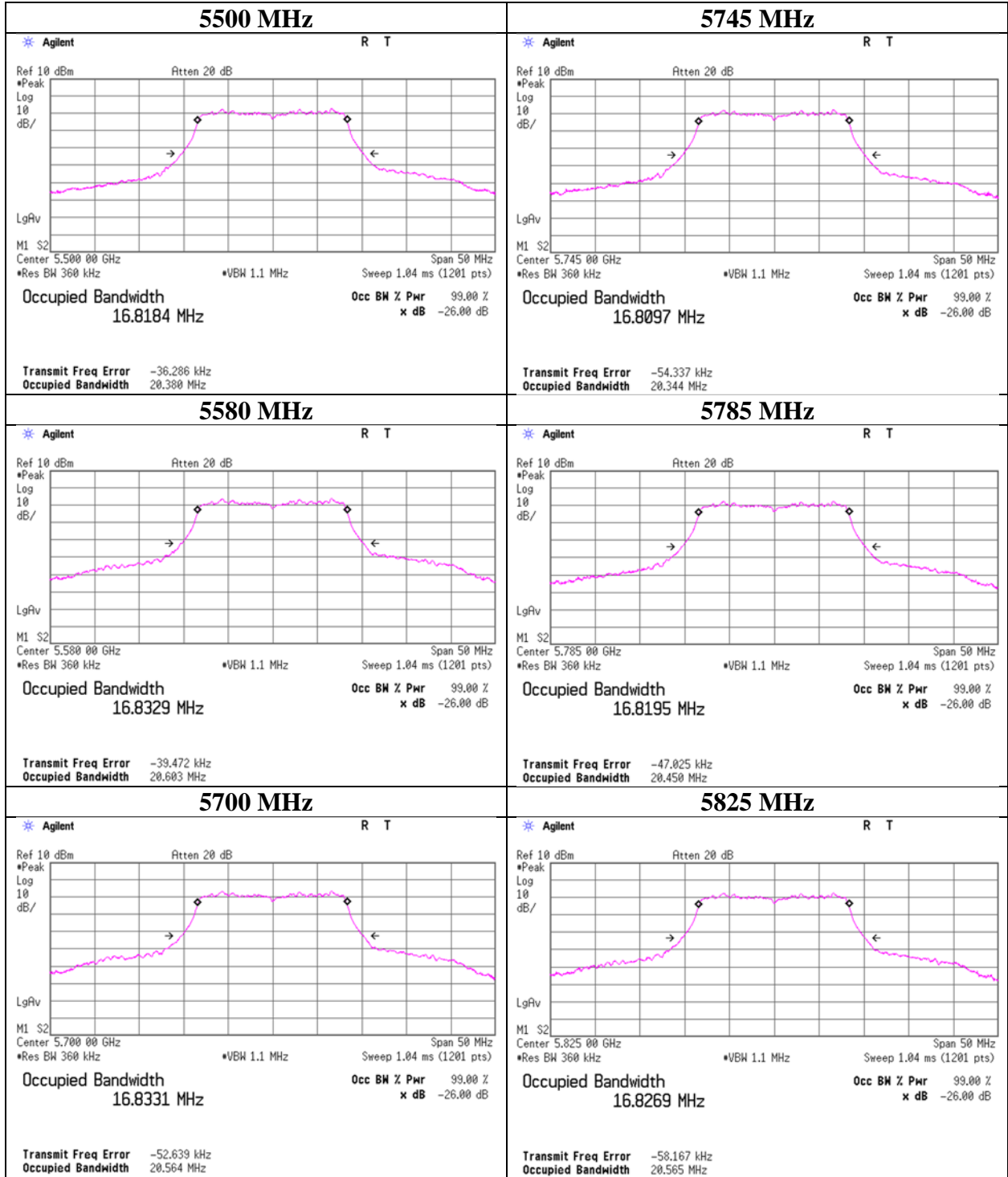

**99 % Occupied Bandwidth**

**11n-20**

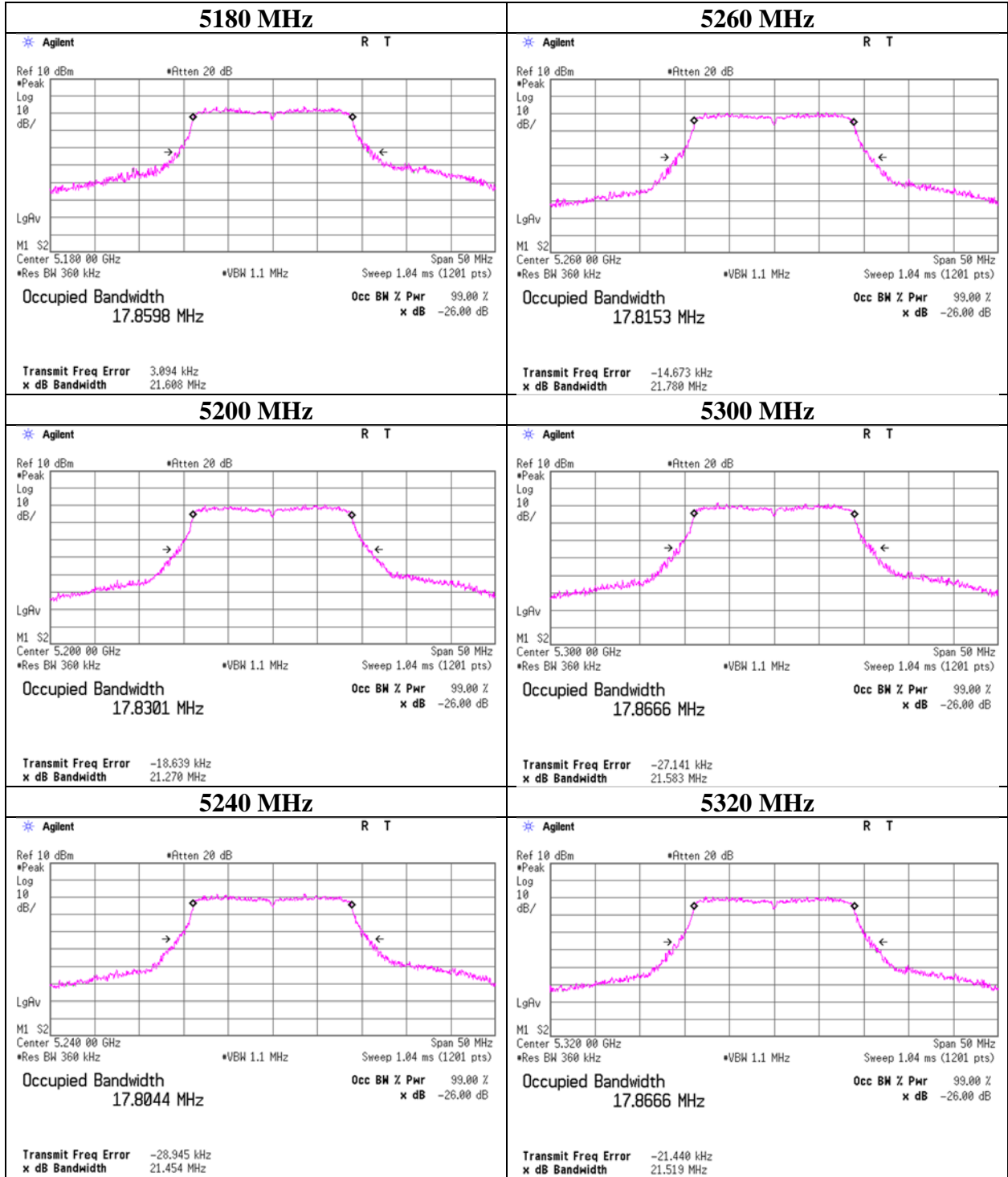

**99 % Occupied Bandwidth**

**11n-20**

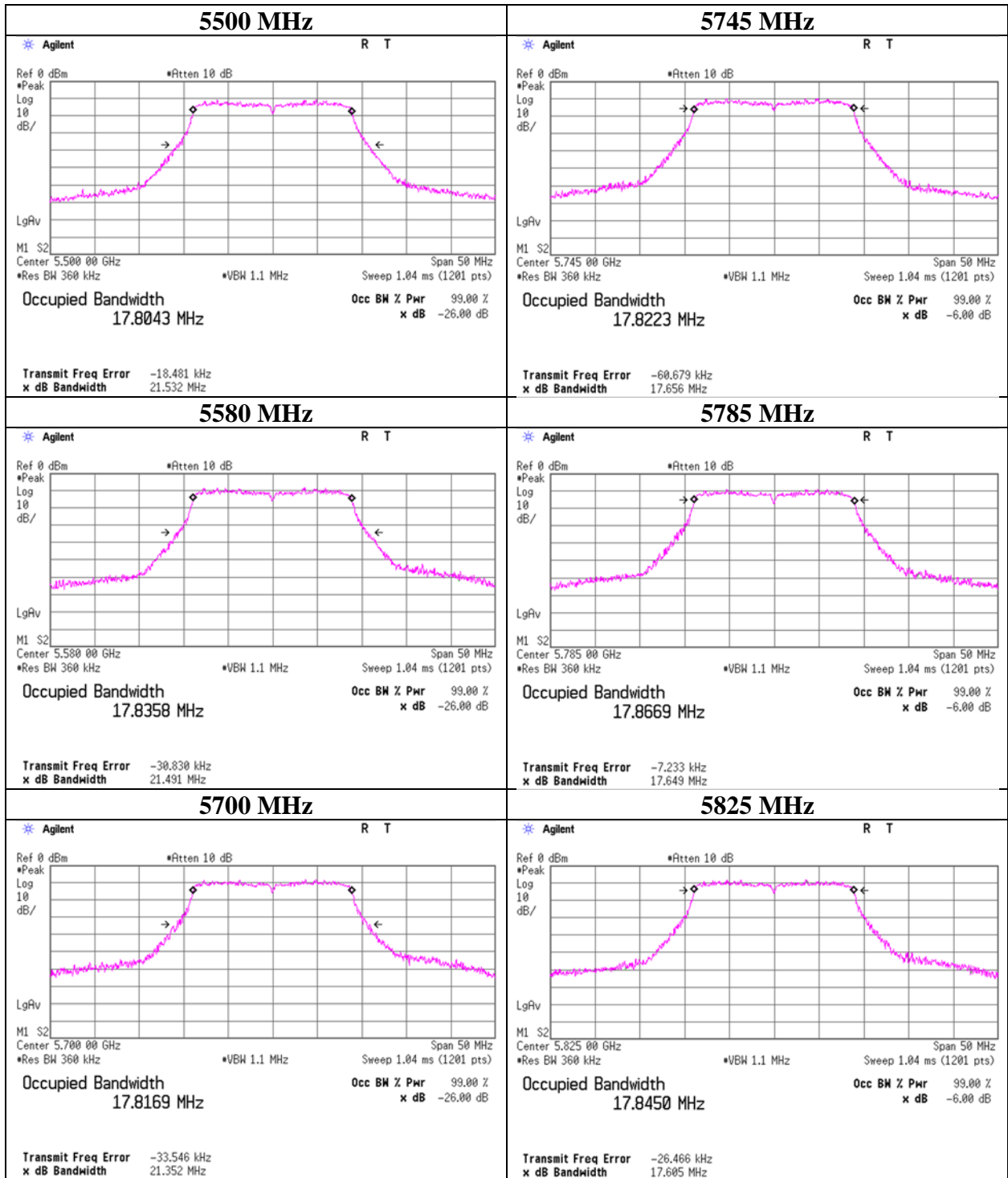

**99 % Occupied Bandwidth**

**11ac-20**

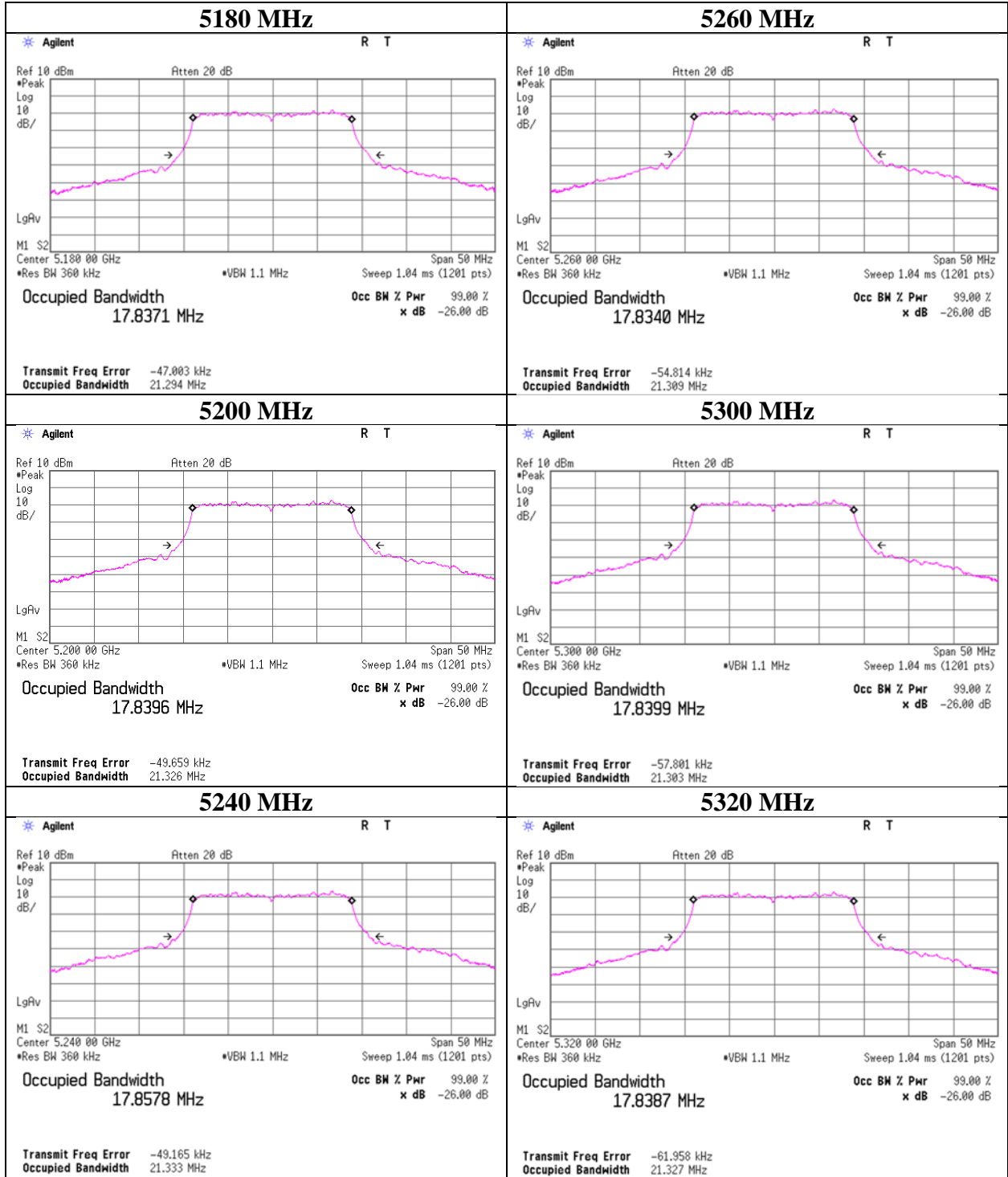

**99 % Occupied Bandwidth**

**11ac-20**

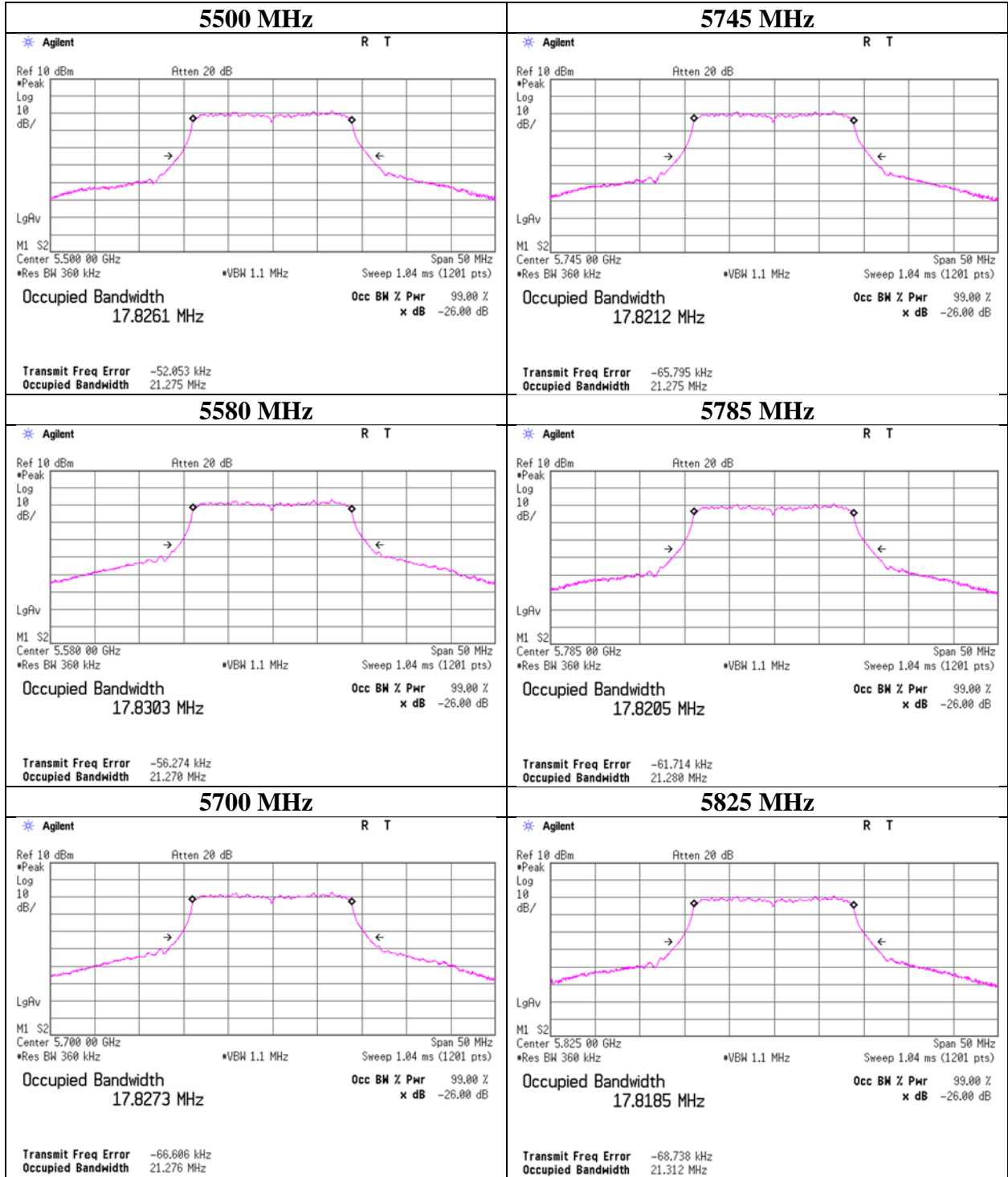

**99 % Occupied Bandwidth**

**11n-40**

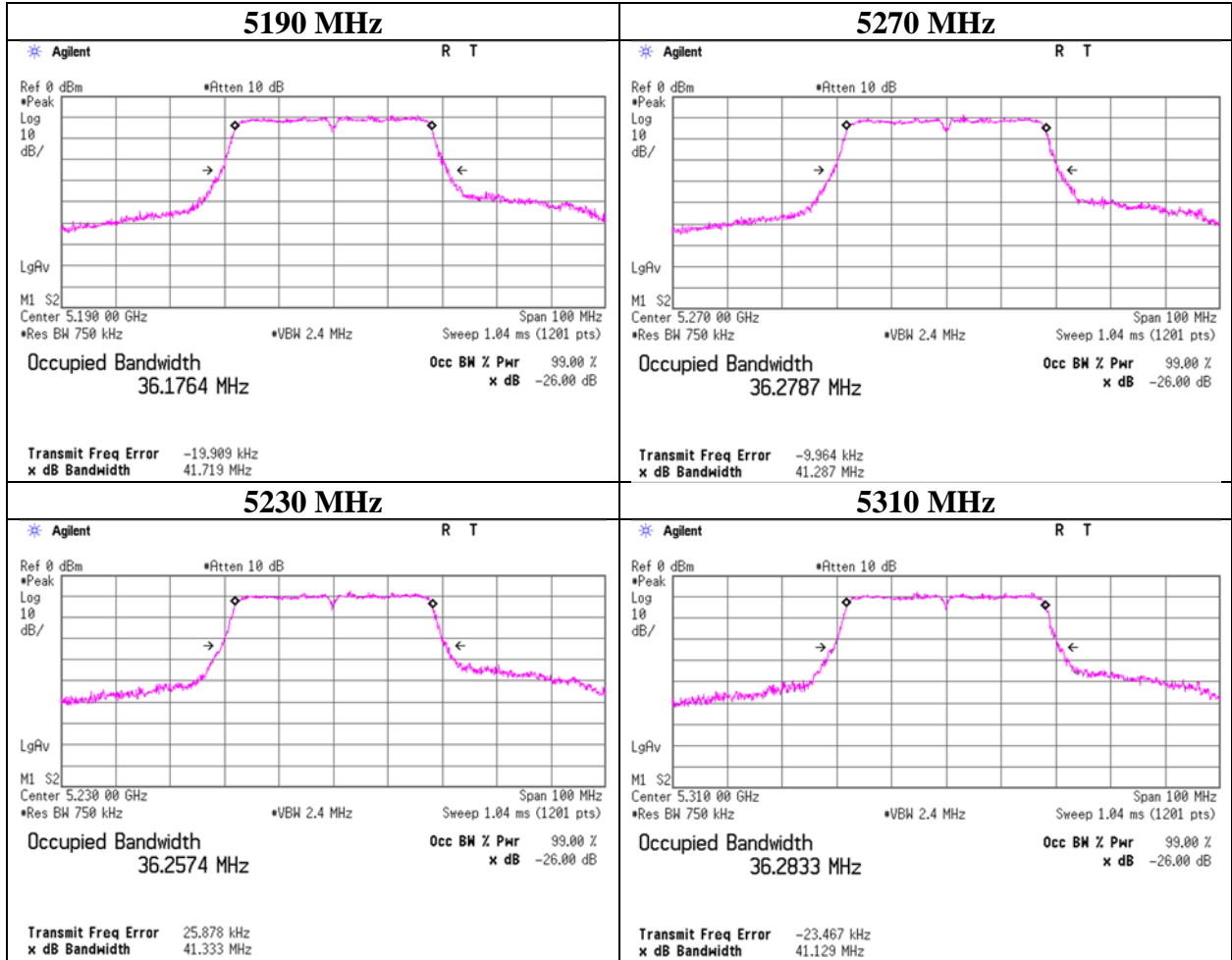

**99 % Occupied Bandwidth**

11n-40

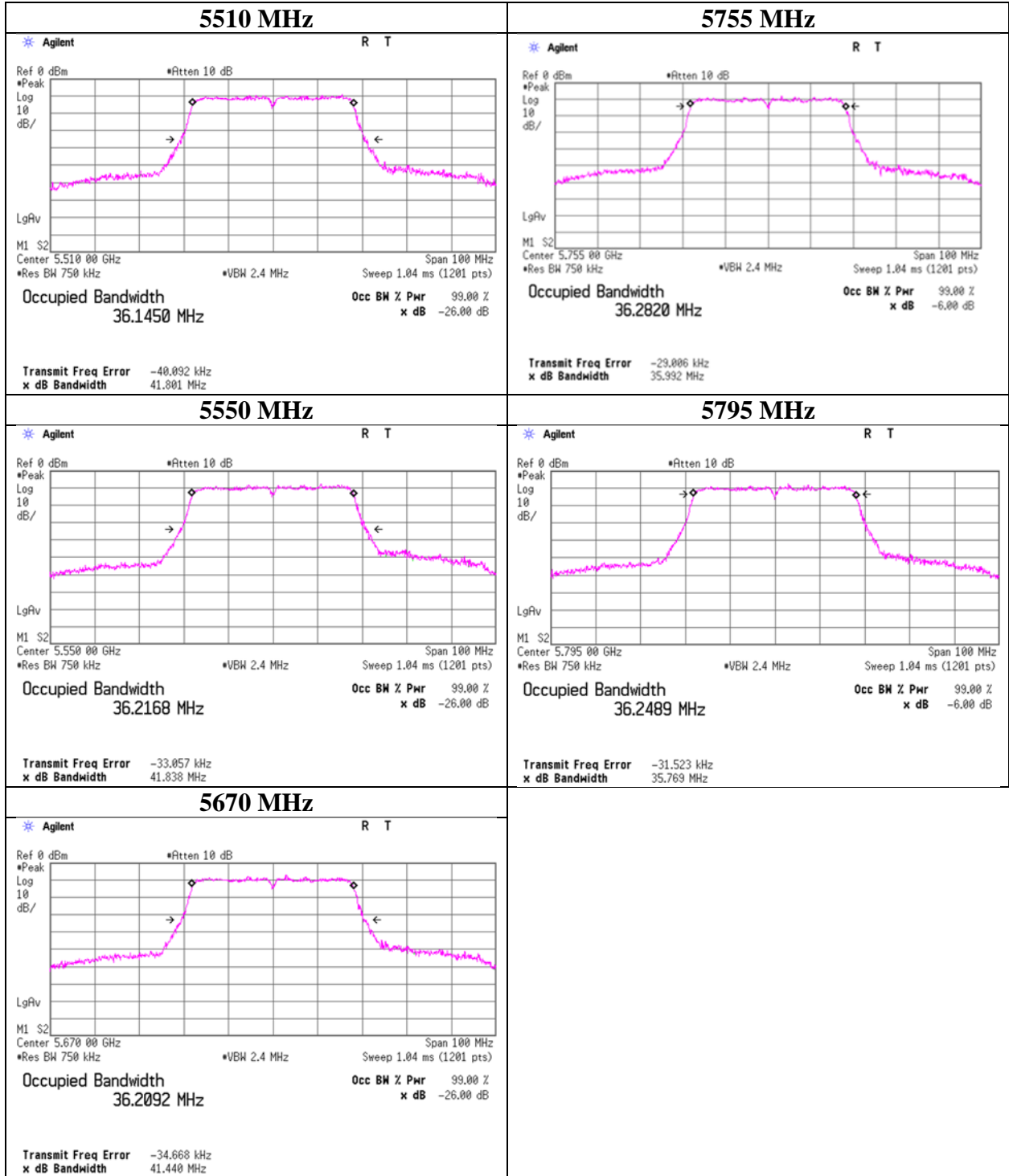



**99 % Occupied Bandwidth**

**11ac-40**

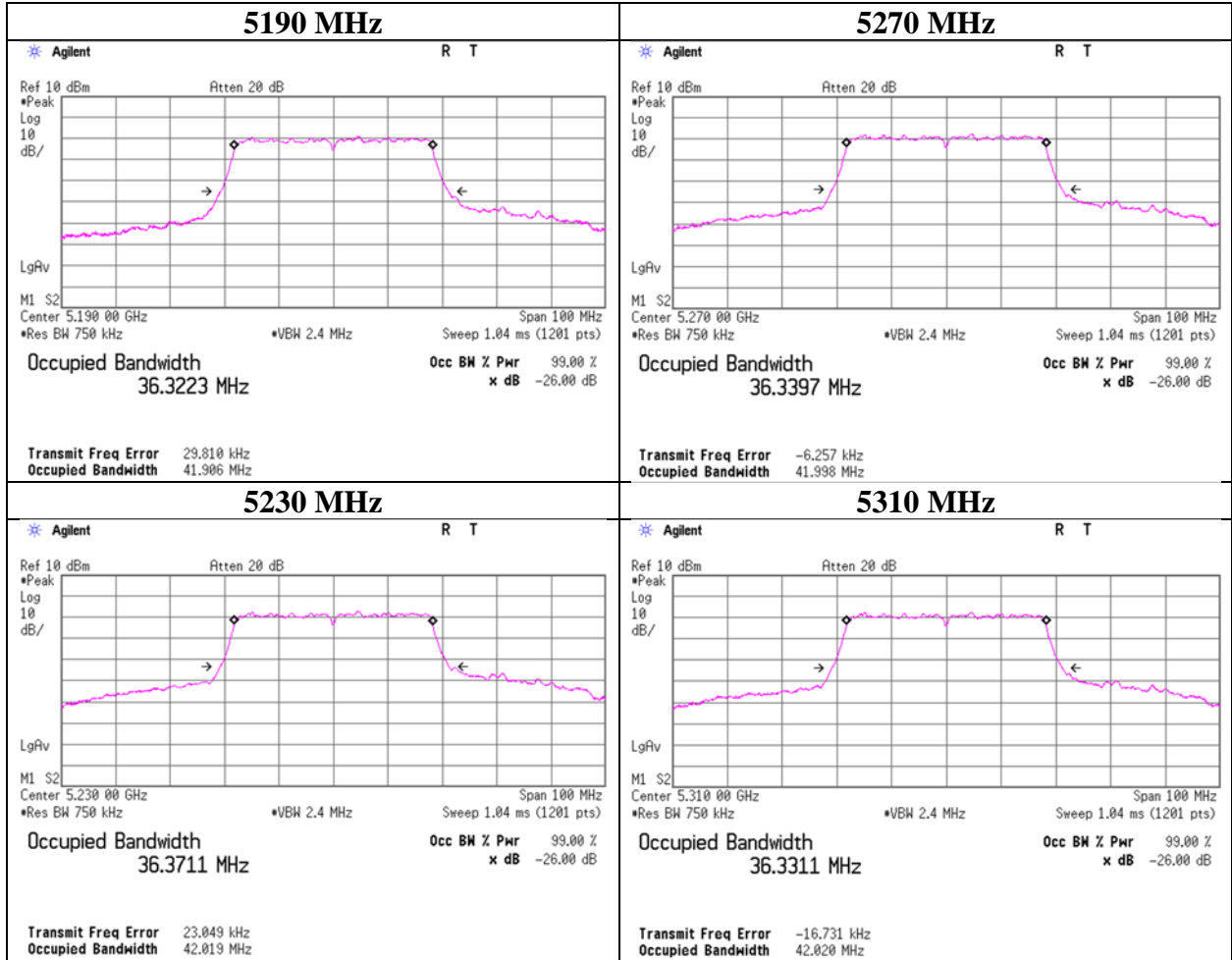

**99 % Occupied Bandwidth**

**11ac-40**

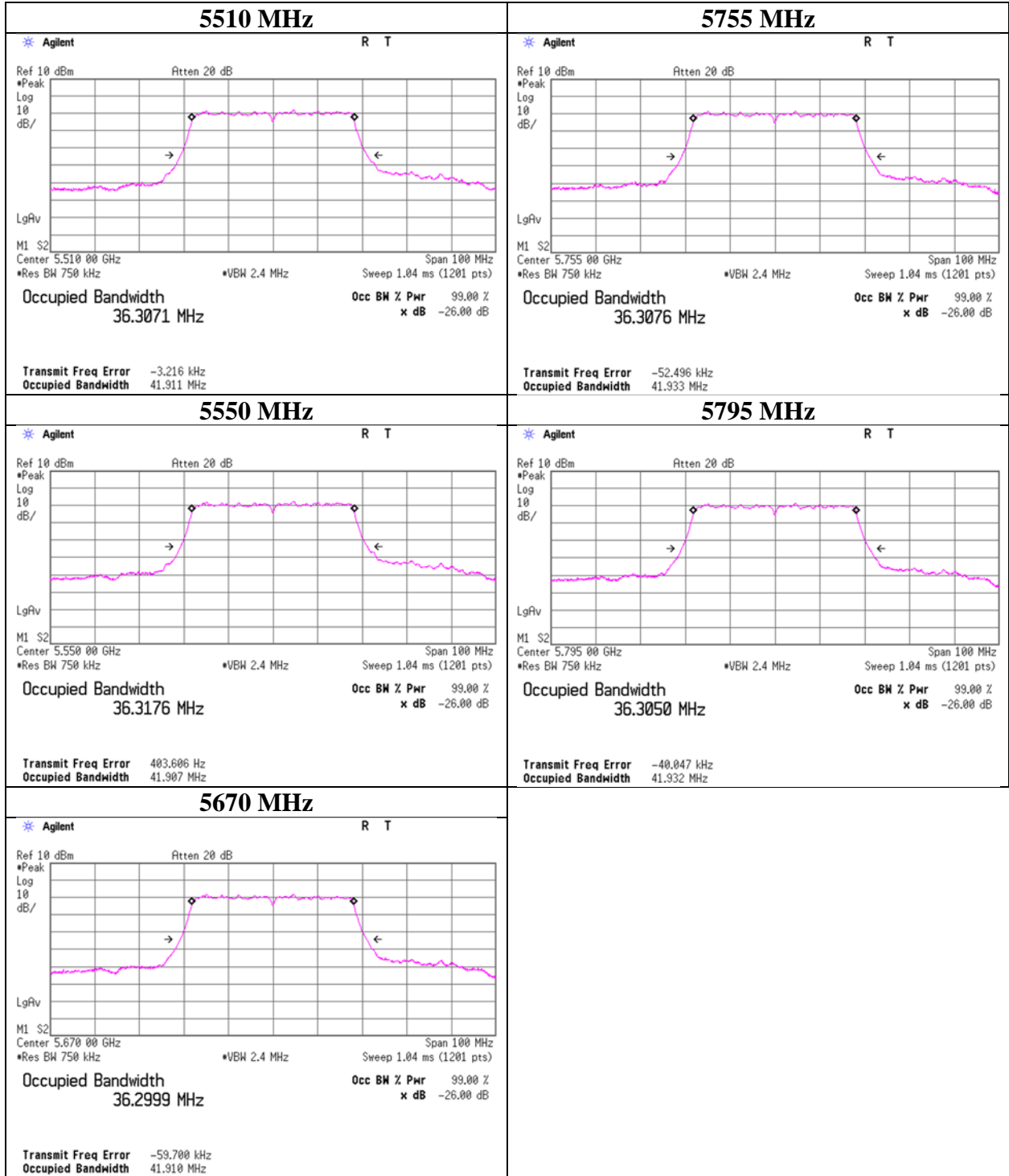

**99 % Occupied Bandwidth**

**11ac-80**

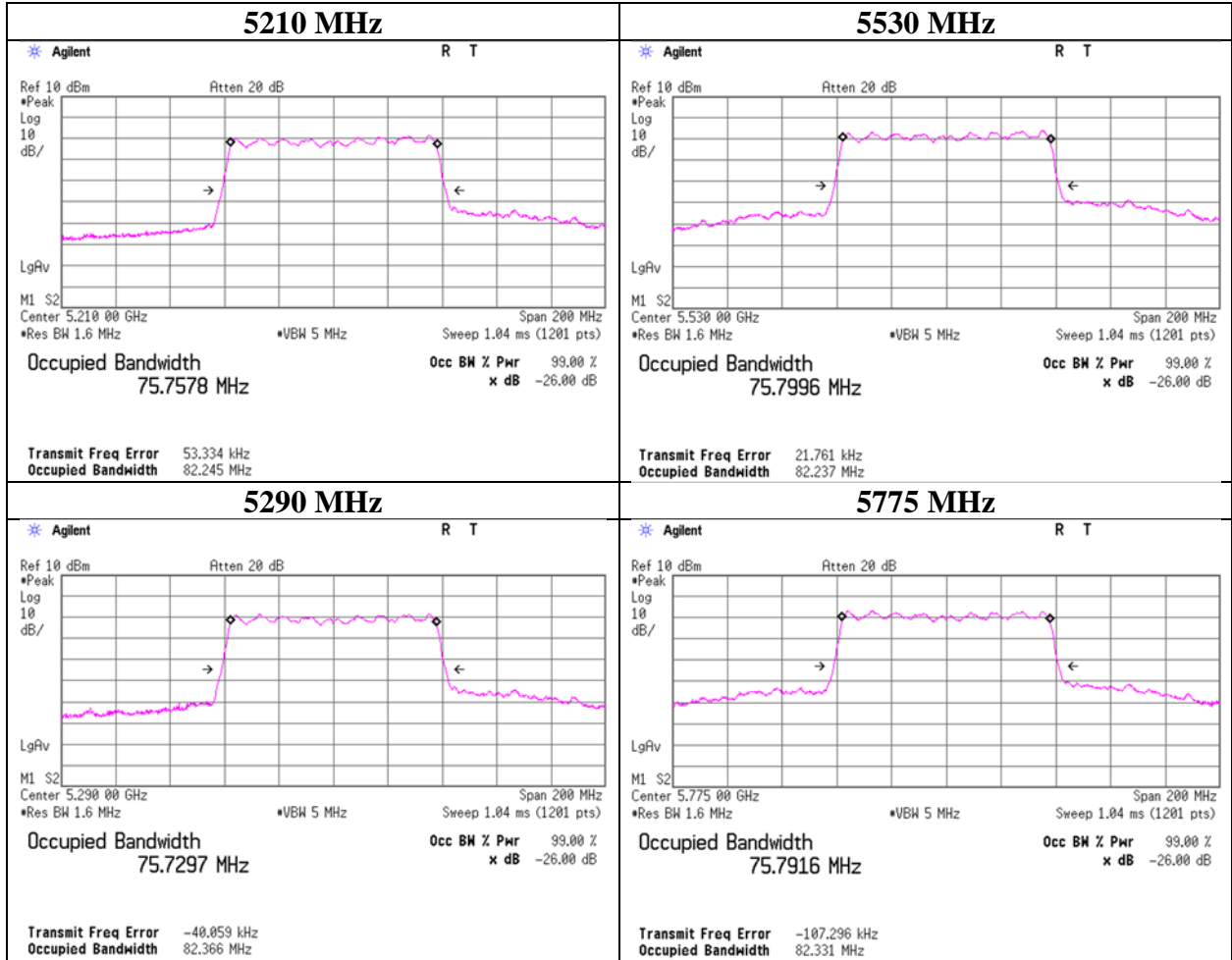

## 6 dB Bandwidth

Test place                      Shonan EMC Lab. No.5 Shielded Room  
Date                              May 20, 2022                      May 24, 2022  
Temperature / Humidity      24 deg. C / 40 % RH            25 deg. C / 46 % RH  
Engineer                        Hiromasa Sato                      Shiro Kobayashi  
Mode                              Tx

11a

Tested Frequency [MHz]	6 dB Bandwidth [MHz]	Limit [MHz]
5745	16.551	> 0.500
5785	16.534	> 0.500
5825	16.533	> 0.500

11n-20

Tested Frequency [MHz]	6 dB Bandwidth [MHz]	Limit [MHz]
5745	17.758	> 0.500
5785	17.721	> 0.500
5825	17.725	> 0.500

11ac-20

Tested Frequency [MHz]	6 dB Bandwidth [MHz]	Limit [MHz]
5745	17.731	> 0.500
5785	17.734	> 0.500
5825	17.727	> 0.500

11n-40

Tested Frequency [MHz]	6 dB Bandwidth [MHz]	Limit [MHz]
5755	36.519	> 0.500
5795	36.542	> 0.500

11ac-40

Tested Frequency [MHz]	6 dB Bandwidth [MHz]	Limit [MHz]
5755	36.498	> 0.500
5795	36.512	> 0.500

11ac-80

Tested Frequency [MHz]	6 dB Bandwidth [MHz]	Limit [MHz]
5775	76.305	> 0.500

### 6 dB Bandwidth

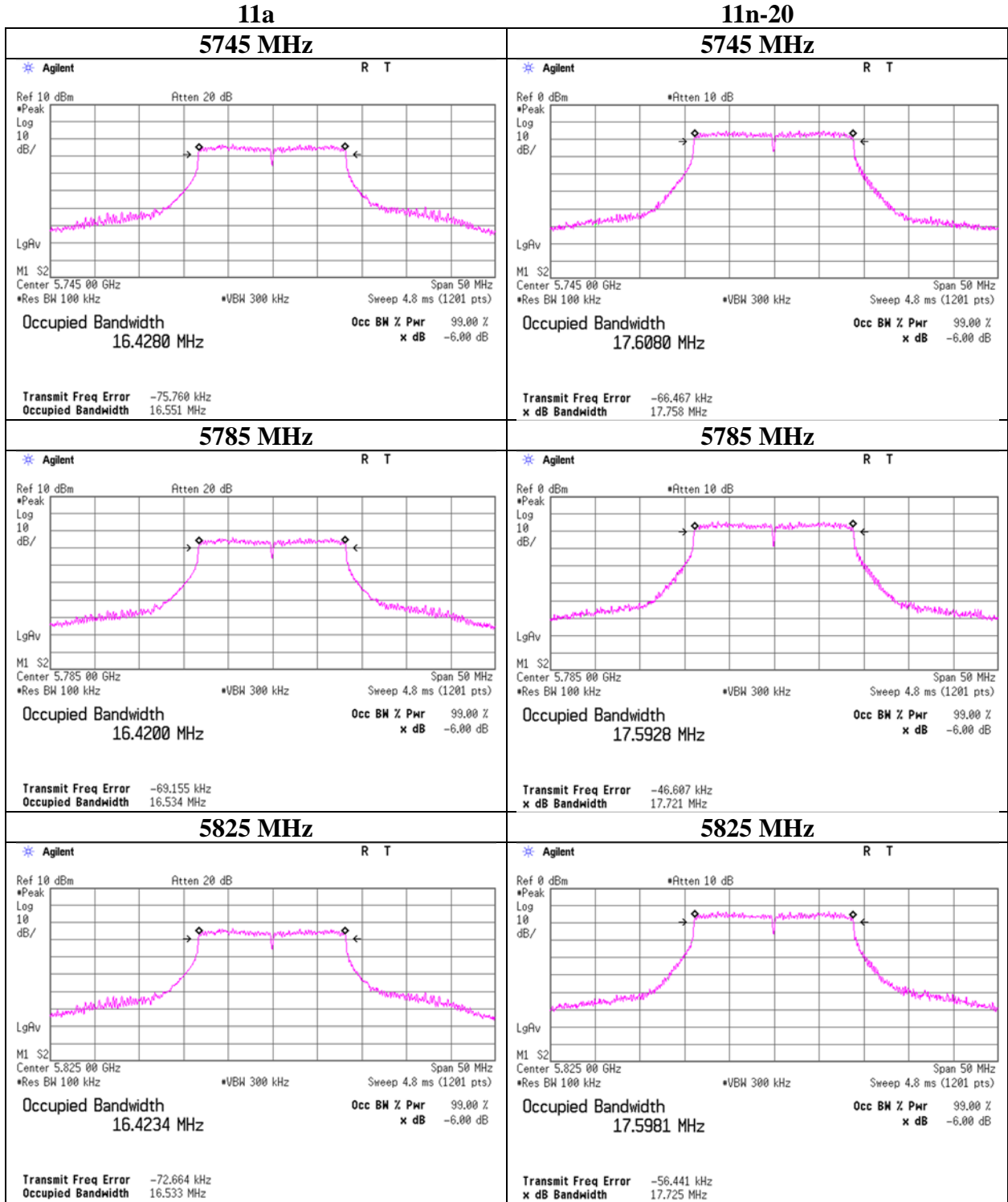

**6 dB Bandwidth**

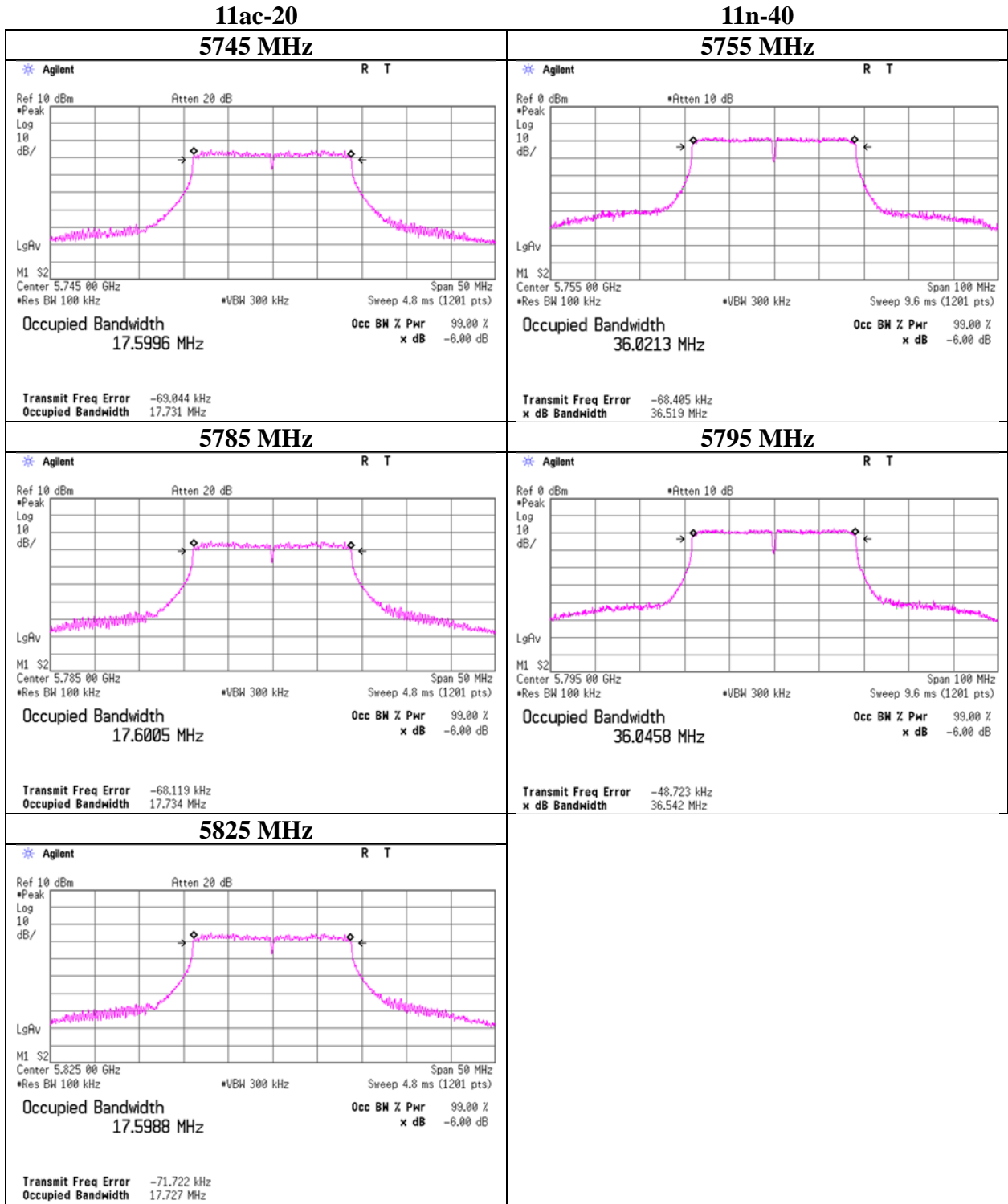

### 6 dB Bandwidth

