



RADIO TEST REPORT

Test Report No. : 11334871S-A-R1

Applicant : Nintendo Co., Ltd.
Type of Equipment : Game Console
Model No. : HAC-001
(for Wireless LAN (2.4 GHz bands) and Bluetooth low energy part)
FCC ID : BKEHAC001
Test regulation : FCC Part 15 Subpart C: 2016
Test Result : Complied

1. This test report shall not be reproduced in full or partial, without the written approval of UL Japan, Inc.
2. The results in this report apply only to the sample tested.
3. This sample tested is in compliance with the above regulation.
4. The test results in this report are traceable to the national or international standards.
5. The opinions and the interpretations to the result of the description in this report are outside scopes where UL Japan has been accredited.
6. This test report covers Radio technical requirements. It does not cover administrative issues such as Manual or non-Radio test related Requirements. (if applicable)
7. This report is a revised version of 11334871S-A. 11334871S-A is replaced with this report.

Date of test: August 18 to November 14, 2016

Representative test engineer: 
Shinichi Takano
Engineer
Consumer Technology Division

Approved by: 
Akio Hayashi
Leader
Consumer Technology Division



- The testing in which "Non-accreditation" is displayed is outside the accreditation scopes in UL Japan.
 There is no testing item of "Non-accreditation".

UL Japan, Inc.

Shonan EMC Lab.

1-22-3 Megumigaoka, Hiratsuka-shi, Kanagawa-ken, 259-1220 JAPAN

Telephone : +81 463 50 6400

Facsimile : +81 463 50 6401

13-EM-F0429

CONTENTS	PAGE
SECTION 1: Customer information.....	4
SECTION 2: Equipment under test (E.U.T.).....	4
SECTION 3: Test specification, procedures & results.....	5
SECTION 4: Operation of E.U.T. during testing.....	8
SECTION 5: Conducted Emission.....	13
SECTION 6: Radiated Spurious Emission	14
SECTION 7: Antenna Terminal Conducted Tests.....	16
APPENDIX 1: Test data	17
Conducted Emission	17
6 dB Bandwidth	20
Maximum Peak Output Power	32
Average Output Power	43
Burst rate confirmation	55
Radiated Spurious Emission	61
Conducted Spurious Emission	105
Power Density	109
99 % Occupied Bandwidth.....	130
APPENDIX 2: Test instruments	141
APPENDIX 3: Photographs of test setup	143
Conducted Emission	143
Radiated Spurious Emission	145
Pre-check of Worst Case Position.....	147

SECTION 1: Customer information

Company Name : Nintendo Co., Ltd.
Address : 11-1 Hokotate-cho, Kamitoba, Minami-ku, Kyoto 601-8501, Japan
Telephone Number : +81-75-662-9600
Facsimile Number : +81-75-662-9624
Contact Person : Kazuya Kuramoto

SECTION 2: Equipment under test (E.U.T.)

2.1 Identification of E.U.T.

Type of Equipment : Game Console
Model No. : HAC-001
Serial No. : Refer to Section 4, Clause 4.2
Rating : DC 3.7 V (battery),
AC Adapter input: AC 100 – 240 V, 50 / 60 Hz, 1 A,
AC Adapter output: DC 5 V – DC 15 V, 2.6 A
Receipt Date of Sample : August 2, 2016
Country of Mass-production : China
Condition of EUT : Production prototype
(Not for Sale: This sample is equivalent to mass-produced items.)
Modification of EUT : No Modification by the test lab.

2.2 Product Description

Model: HAC-001 (referred to as the EUT in this report) is a Game Console.

General Specification

Clock frequency(ies) in the system : 37.4 MHz

Radio Specification

Radio Type : Transceiver
Frequency of Operation : Wireless LAN part: 2412 MHz - 2472 MHz,
W52: 5180 MHz -5240 MHz,
W53: 5260 MHz -5320 MHz,
W56: 5500 MHz -5700 MHz *,
W58: 5745 MHz -5825 MHz *,
Bluetooth part: 2402 MHz - 2480 MHz
Modulation : Wireless LAN part:
2.4 GHz bands: DBPSK, DQPSK, CCK, OFDM
5 GHz bands: OFDM
Bluetooth part:
BDR (Basic Data Rate): GFSK
EDR (Enhanced Data Rate): $\pi/4$ -DQPSK, 8DPSK
LE (Low Energy mode): GFSK
Antenna type : PCB Antenna (Dipole)
Antenna connector : (Ant: 0): MHF 4L, (Ant: 1): MHF II
Antenna Gain : 2.4 GHz band:
-0.70 dBi max (ANT0: Wireless LAN & Bluetooth), -8.38 dBi max (ANT1: Wireless LAN)
5 GHz band:
+3.31 dBi max (ANT0: Wireless LAN), -0.96 dBi max (ANT1: Wireless LAN)
Operation temperature : +5 deg.C to +35 deg.C

Remarks: This Wireless Module consists of 1 chip each of 5 GHz band and 2.4 GHz band.

*This model does not have 40MHz Bandwidth mode on W56 and W58.

UL Japan, Inc.

Shonan EMC Lab.

1-22-3 Megumigaoka, Hiratsuka-shi, Kanagawa-ken, 259-1220 JAPAN
Telephone : +81 463 50 6400
Facsimile : +81 463 50 6401

SECTION 3: Test specification, procedures & results

3.1 Test Specification

Test Specification : FCC Part 15 Subpart C
FCC Part 15 final revised on November 14, 2016 and effective December 14, 2016
Title : FCC 47CFR Part15 Radio Frequency Device Subpart C Intentional Radiators
Section 15.207 Conducted limits
Section 15.247 Operation within the bands 902-928MHz,
2400-2483.5MHz, and 5725-5850MHz

* The revision on November 14, 2016, does not affect the test specification applied to the EUT.

** The EUT has been tested for compliance with FCC Part 15 Subpart B / ICES-003 Issue 6: 2016.

3.2 Procedures and results

Item	Test Procedure	Specification	Worst margin	Results	Remarks
Conducted Emission	FCC: ANSI C63.10-2013 6. Standard test methods IC: RSS-Gen 8.8	FCC: Section 15.207 IC: RSS-Gen 8.8	8.7 dB , AV 0.45760 MHz, N, (Tx, OFDM VHT20, 2437 MHz)	Complied	-
6 dB Bandwidth	FCC: KDB 558074 D01 DTS Meas Guidance v03r05 IC: -	FCC: Section 15.247(a)(2) IC: RSS-247 5.2(1)	See data.	Complied	Conducted
Maximum Peak Output Power	FCC: KDB 558074 D01 DTS Meas Guidance v03r05 IC: RSS-Gen 6.12	FCC: Section 15.247(b)(3) IC: RSS-247 5.4(4)		Complied	Conducted
Power Density	FCC: KDB 558074 D01 DTS Meas Guidance v03r05 IC: -	FCC: Section 15.247(e) IC: RSS-247 5.2(2)		Complied	Conducted
Spurious Emission Restricted Band Edges	FCC: KDB 558074 D01 DTS Meas Guidance v03r05 IC: RSS-Gen 6.13	FCC: Section 15.247(d) IC: RSS-247 5.5 RSS-Gen 8.9 RSS-Gen 8.10	1.3 dB Vert., 2390.000 MHz, AV (Tx IEEE802.11n-40,MIMO, 2422 MHz)	Complied	Conducted (below 30 MHz)/ Radiated (above 30 MHz) *1)
99 % Occupied Bandwidth	IC: RSS-Gen 6.6	IC: -	N/A	-	Conducted

Note: UL Japan, Inc.'s EMI Work Procedures No. 13-EM-W0420 and 13-EM-W0422.

*1) Radiated test was selected over 30 MHz based on section 15.247(d) and KDB 558074 D01 DTS Meas Guidance v03r05 12.2.7.

* In case any questions arise about test procedure, ANSI C63.10: 2013 is also referred.

FCC Part 15.31 (e)

This EUT provides stable voltage (DC 3.3 V) constantly to RF Part regardless of input voltage. Therefore, the EUT complies with the requirement.

FCC Part 15.203 Antenna requirement

It is impossible for end users to replace the antenna, because the antenna is mounted inside of the EUT. Therefore, the EUT complies with the requirement.

UL Japan, Inc.

Shonan EMC Lab.

1-22-3 Megumigaoka, Hiratsuka-shi, Kanagawa-ken, 259-1220 JAPAN

Telephone : +81 463 50 6400

Facsimile : +81 463 50 6401

3.3 Addition to standard

Item	Test Procedure	Specification	Worst margin	Results	Remarks
99% Occupied Bandwidth	IC: RSS-Gen 6.6	IC: -	N/A	-	Conducted

Other than above, no addition, exclusion nor deviation has been made from the standard.

3.4 Uncertainty

The following uncertainties have been calculated to provide a confidence level of 95 % using a coverage factor $k = 2$.
Shonan EMC Lab.

Item	Frequency range	Uncertainty (+/-)			
		No. 1 SAC / SR	No. 2 SAC / SR	No. 3 SAC / SR	No. 4 SAC / SR
Conducted emission (AC Mains) LISN	150 kHz-30 MHz	2.6 dB	2.5 dB	2.6 dB	2.5 dB
Radiated emission (Measurement distance: 3 m)	9 kHz-30 MHz	3.1 dB	3.1 dB	3.1 dB	-
	30 MHz-200 MHz	4.6 dB	4.4 dB	4.6 dB	-
	200 MHz-1 GHz	5.8 dB	5.7 dB	5.8 dB	-
	1 GHz-13 GHz	4.9 dB	4.9 dB	4.9 dB	-
Radiated emission (Measurement distance: 1 m)	13 GHz-18 GHz	4.6 dB	4.6 dB	4.6 dB	-
	18 GHz-40 GHz	4.9 dB	4.9 dB	4.9 dB	-

SAC=Semi-Anechoic Chamber

SR= Shielded Room is applied besides radiated emission

Antenna terminal test	Uncertainty (+/-)
Power Measurement above 1 GHz (Average Detector)_SPM-06	0.72 dB
Power Measurement above 1 GHz (Peak Detector)_SPM-06	0.85 dB
Power Measurement above 1 GHz (Average Detector)_SPM-07	0.74 dB
Power Measurement above 1 GHz (Peak Detector)_SPM-07	0.91 dB
Spurious emission (Conducted) below 1GHz	1.6 dB
Spurious emission (Conducted) 1 GHz-3 GHz	1.3 dB
Spurious emission (Conducted) 3 GHz-18 GHz	2.2 dB
Spurious emission (Conducted) 18 GHz-26.5 GHz	2.3 dB
Spurious emission (Conducted) 26.5 GHz-40 GHz	2.4 dB
Bandwidth Measurement	1.01 %
Duty cycle and Time Measurement	0.012 %

Conducted Emission test

The data listed in this test report has enough margin, more than the site margin.

Radiated emission test

The data listed in this report meets the limits unless the uncertainty is taken into consideration.

3.5 Test Location

UL Japan, Inc. Shonan EMC Lab.
1-22-3, Megumigaoka, Hiratsuka-shi, Kanagawa-ken 259-1220 JAPAN
Telephone: +81 463 50 6400, Facsimile: +81 463 50 6401
JAB Accreditation No. RTL02610

Test site	IC Registration Number	Width x Depth x Height (m)	Size of reference ground plane (m) / horizontal conducting p lane	Maximum measurement distance
No.1 Semi-anechoic chamber	2973D-1	20.6 x 11.3 x 7.65	20.6 x 11.3	10 m
No.2 Semi-anechoic chamber	2973D-2	20.6 x 11.3 x 7.65	20.6 x 11.3	10 m
No.3 Semi-anechoic chamber	2973D-3	12.7 x 7.7 x 5.35	12.7 x 7.7	5 m
No.4 Semi-anechoic chamber	-	8.1 x 5.1 x 3.55	8.1 x 5.1	-
No.1 Shielded room	-	6.8 x 4.1 x 2.7	6.8 x 4.1	-
No.2 Shielded room	-	6.8 x 4.1 x 2.7	6.8 x 4.1	-
No.3 Shielded room	-	6.3 x 4.7 x 2.7	6.3 x 4.7	-
No.4 Shielded room	-	4.4 x 4.7 x 2.7	4.4 x 4.7	-
No.5 Shielded room	-	7.8 x 6.4 x 2.7	7.8 x 6.4	-
No.6 Shielded room	-	7.8 x 6.4 x 2.7	7.8 x 6.4	-
No.8 shielded room	-	3.45 x 5.5 x 2.4	3.45 x 5.5	-
No.1 Measurement room	-	2.55 x 4.1 x 2.5	-	-

3.6 Test data, Test instruments, and Test set up

Refer to APPENDIX.

SECTION 4: Operation of E.U.T. during testing

4.1 Operating Mode(s)

*1) Test operating mode was determined as follows according to “Section 1 of 6 802.11 a/b/g/n testing - Managing Complex Regulatory Approvals - ” of TCB Council Workshop October 2009 and also was judged the necessity of OFDM VHT mode by the pre-test.

Test item	Mode	Tested frequency	Worst data rate *2)	Antenna *2)
Conducted emission, Radiated emission (below 1 GHz), Out of band emissions (Conducted) *1)	Transmitting (Tx), OFDM VHT20, MIMO	2437 MHz	MCS 3, PN9	0 & 1
	Transmitting (Tx), Bluetooth Low energy (BT LE)	2402 MHz, 2440 MHz, 2480 MHz	PRBS9	0
6 dB bandwidth, Occupied Bandwidth (99 %), Maximum output power, Power density	Transmitting (Tx), IEEE 802.11b (11b)	2412 MHz, 2437 MHz, 2462 MHz, 2467 MHz, 2472 MHz *5)	11 Mbps, PN9	1
	Transmitting (Tx), IEEE 802.11g (11g)	2412 MHz, 2437 MHz, 2462 MHz, 2467 MHz, 2472 MHz *5)	48 Mbps, PN9	0 (2412 MHz – 2462 MHz), 1 (2467 MHz, 2472 MHz)
	Transmitting (Tx), IEEE 802.11n HT20 (11n-20), SISO	2412 MHz, 2437 MHz, 2462 MHz, 2467 MHz, 2472 MHz *5)	MCS 3, PN9	1
	Transmitting (Tx), IEEE 802.11n HT20 (11n-20), MIMO	2412 MHz, 2437 MHz, 2462 MHz, 2467 MHz, 2472 MHz *5)	MCS11, PN9	0 & 1
	Transmitting (Tx), OFDM VHT20, SISO	2412 MHz, 2437 MHz, 2462 MHz, 2467 MHz, 2472 MHz *5)	MCS 3, PN9	1
	Transmitting (Tx), OFDM VHT20, MIMO	2412 MHz, 2437 MHz, 2462 MHz, 2467 MHz, 2472 MHz *5)	MCS 3, PN9	0 & 1
	Transmitting (Tx), IEEE 802.11n HT40 (11n-40), SISO	2422 MHz, 2437 MHz, 2452 MHz, 2457 MHz, 2462 MHz *6)	MCS 3, PN9	0
	Transmitting (Tx), IEEE 802.11n HT40 (11n-40), MIMO	2422 MHz, 2437 MHz, 2452 MHz, 2457 MHz, 2462 MHz *6)	MCS11, PN9	0 & 1
	Transmitting (Tx), OFDM VHT40, SISO	2422 MHz, 2437 MHz, 2452 MHz, 2457 MHz, 2462 MHz *6)	MCS 3, PN9	0
	Transmitting (Tx), OFDM VHT40, MIMO	2422 MHz, 2437 MHz, 2452 MHz, 2457 MHz, 2462 MHz *6)	MCS 3, PN9	0 & 1
	Transmitting (Tx), Bluetooth Low energy (BT LE)	2402 MHz, 2440 MHz, 2480 MHz	PRBS9	0
Radiated emission (above 1 GHz) *3)	Transmitting (Tx), IEEE 802.11b (11b)	2412 MHz, 2437 MHz, 2462 MHz, 2467 MHz, 2472 MHz *5)	11 Mbps, PN9	0
	Transmitting (Tx), OFDM VHT20, MIMO	2412 MHz, 2437 MHz, 2462 MHz, 2467 MHz, 2472 MHz *5)	MCS 3, PN9	0 & 1
	Transmitting (Tx), IEEE 802.11n HT20 (11n-20), SISO *4)	2412 MHz, 2462 MHz, 2467 MHz, 2472 MHz *5)	MCS 3, PN9	1
	Transmitting (Tx), IEEE 802.11n HT40 (11n-40), MIMO	2422 MHz, 2437 MHz, 2457 MHz, 2462 MHz *7)	MCS 11, PN9	0 & 1
	Transmitting (Tx), IEEE 802.11n HT40 (11n-40), SISO *4)	2422 MHz, 2462 MHz	MCS 3, PN9	0
	Transmitting (Tx), Bluetooth Low energy (BT LE)	2402 MHz, 2440 MHz, 2480 MHz	PRBS9	0

*Power of the EUT was set by the software as follows;

Power settings: (Wireless LAN): Fixed (refer to power setting table)
(Bluetooth low energy): Fixed

Software: (Wireless LAN): cmd.exe, Ver. 6.3.9600.17415,
(Bluetooth low energy): Bluetool.exe, Ver.1.9.3.0

*This setting of software is the worst case. Any conditions under the normal use do not exceed the condition of setting. In addition, end users cannot change the settings of the output power of the product.

*2) The worst condition was determined based on the test result of Maximum Peak Output Power.

*3) Since 11g, 11n-20 and OFDM VHT mode have the same modulation method and no differences in transmitting specification, test was performed on the representative mode that had the highest peak output power.

*4) This mode wasn't worst, but only band edge of spurious emissions were measured for confirmation.

*5) The channel on 2462 MHz and 2467 MHz were measured, since the power setting of the channel on 2462 MHz and 2467 MHz were higher than the channel on 2472 MHz.

*6) The channel on 2452 MHz and 2457 MHz were measured, since the power setting of the channel on 2452 MHz and 2457 MHz were higher than the channel on 2462 MHz.

*7) The channel on 2457 MHz were measured, since the power setting of the channel on 2457 MHz were higher than the channel on 2462 MHz.

4.2 Configuration and peripherals

Wireless LAN

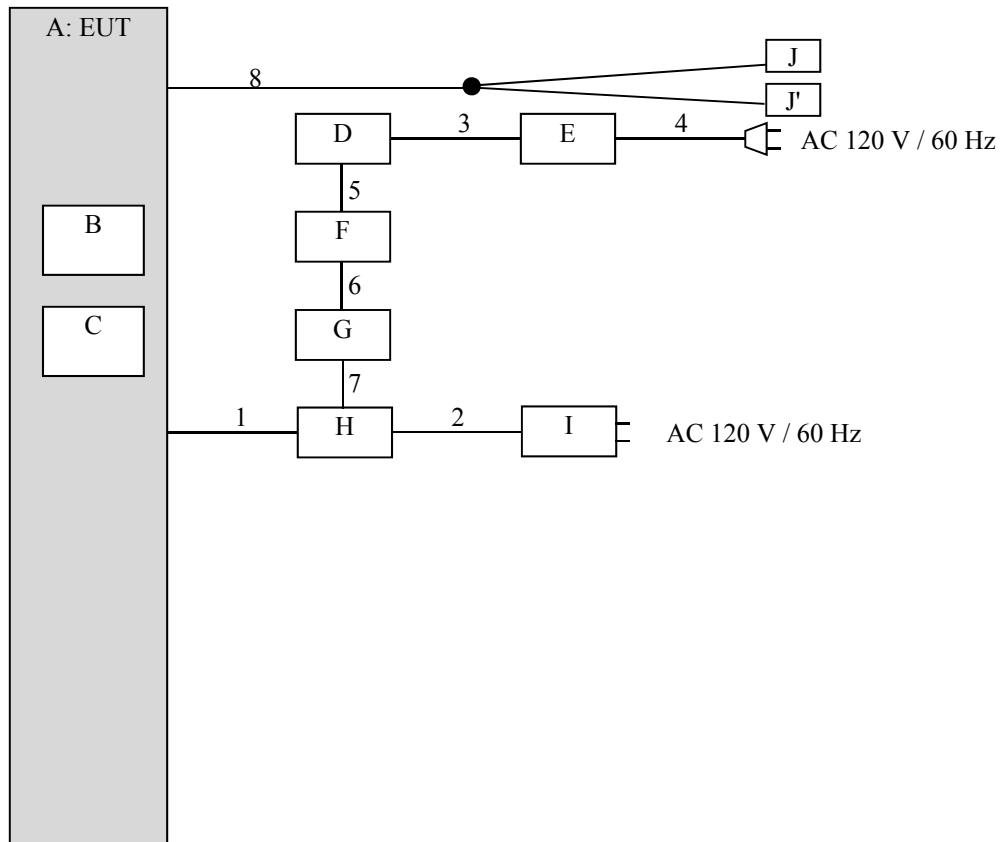

* Cabling and setup(s) were taken into consideration and test data was taken under worse case conditions.

UL Japan, Inc.

Shonan EMC Lab.

1-22-3 Megumigaoka, Hiratsuka-shi, Kanagawa-ken, 259-1220 JAPAN

Telephone : +81 463 50 6400

Facsimile : +81 463 50 6401

Bluetooth Low Energy

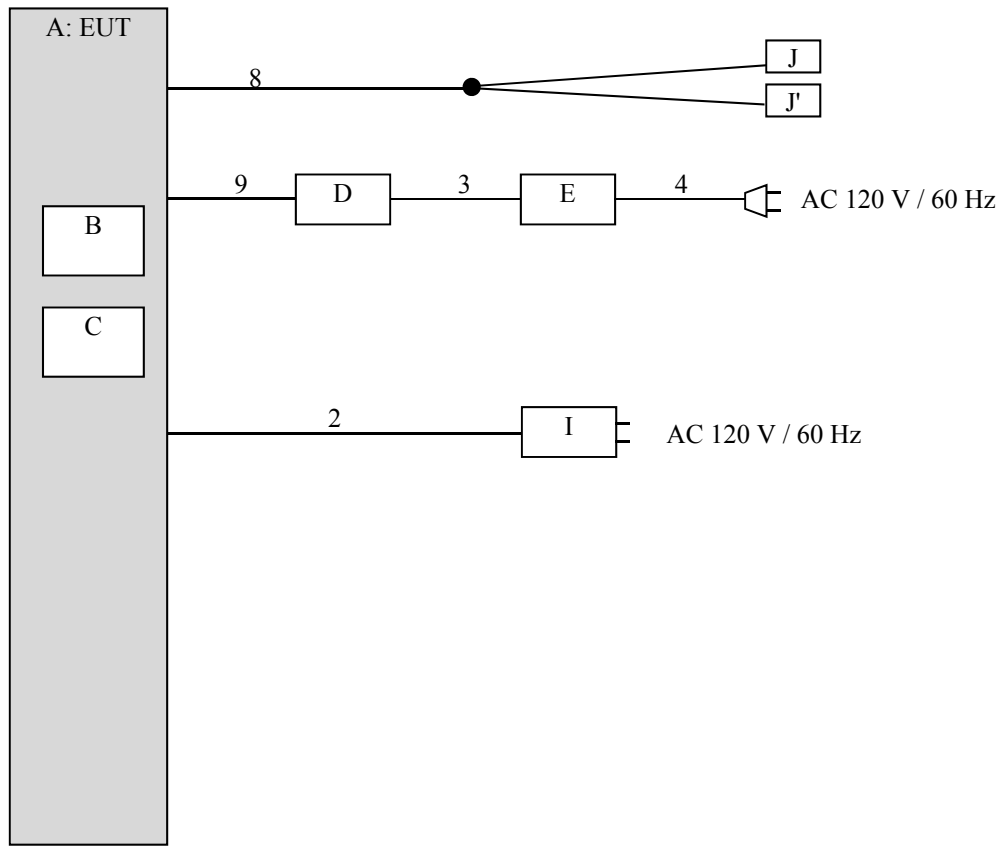

* Cabling and setup(s) were taken into consideration and test data was taken under worse case conditions.

Description of EUT and support equipment

No.	Item	Model number	Serial number	Manufacturer	Remarks
A	Game Console	HAC-001	XAW0150000760 *1) XAW0150000754 *2) XAW0150000359 *3) XAW0150000723 *4)	Nintendo	EUT
B	Game Card	HAC-008	001	Nintendo	-
C	Micro SD Memory	RP-SMEB08GJK	UJ3AA005855	Panasonic	-
D	Laptop PC	HP EliteBook 820G1	JPA416GD4K	hp	-
E	AC Adapter	HSTNN-LA35	WCWVT0A1R5SORI	hp	-
F	GIGA Ethernet Adapter	LAN-GTJU3	61L349604916A	Logitec	-
G	Wii LAN ADAPTER	RVL-015	40F407557DB7	Nintendo	-
H	SDEV Cradle	HAT-003	XZL0000000605	Nintendo	-
I	AC Adapter	HAC-002	-	Nintendo	-
J, J'	Headphone	-	-	Nintendo	-

- *1) Used for Antenna Terminal conducted test for Wireless LAN mode (Type B).
- *2) Used for Conducted Emission test and Radiated Emission test for Wireless LAN mode (Type B).
- *3) Used for Antenna Terminal conducted test for Bluetooth Low Energy mode (Type A).
- *4) Used for Conducted Emission test and Radiated Emission test for Bluetooth Low Energy mode (Type B).
- *The EUT for final test was selected based on following preliminary test.
- Radiated Emission: Comparison of Type A and Type B on Band Edges, Harmonics and Spurious emission.
- Conducted Emission: Comparison of Type A and Type B on representative mode.
- Antenna Terminal Conducted test: Comparison of Type A and Type B on Output Power

Accessory and model differences

The difference between Type A and Type B is as following table.

The two crystals are compatible and are electrically identical having same radio parameters.

Parts	Manufacturer	
	Type A	Type B
Crystal (X501)	TXC	DAISHINKU

So, for the all tests, the E.U.T. was selected worse type by preliminary tests.

List of cables used

No.	Name	Length (m)	Shield		Remarks
			Cable	Connector	
1	USB	0.4	Shielded	Shielded	-
2	USB	1.8	Shielded	Shielded	-
3	DC	1.8	Unshielded	Unshielded	-
4	AC	0.9	Unshielded	Unshielded	-
5	USB	0.1	Shielded	Shielded	-
6	LAN	0.5	Unshielded	Unshielded	-
7	USB	0.15	Shielded	Shielded	-
8	Headphone	0.5 + 0.3	Shielded	Shielded	-
9	USB	1.8	Shielded	Shielded	Only Bluetooth sample (for test setting only)

UL Japan, Inc.

Shonan EMC Lab.

1-22-3 Megumigaoka, Hiratsuka-shi, Kanagawa-ken, 259-1220 JAPAN

Telephone : +81 463 50 6400

Facsimile : +81 463 50 6401

SECTION 5: Conducted Emission

Test Procedure and conditions

EUT was placed on a platform of nominal size, 1.0 m by 1.5 m, raised 0.8 m above the conducting ground plane. The table is made of Styrofoam and covered with polyvinyl chloride. That has very low permittivity. The rear of tabletop was located 40 cm to the vertical conducting plane. The rear of EUT, including peripherals aligned and flushed with rear of tabletop. All other surfaces of tabletop were at least 80cm from any other grounded conducting surface. EUT was located 80 cm from a Line Impedance Stabilization Network (LISN) / Artificial mains Network (AMN) and excess AC cable was bundled in center.

I/O cables that were connected to the peripherals were bundled in center. They were folded back and forth forming a bundle 30 cm to 40 cm long and were hanged at a 40 cm height to the ground plane. All unused 50ohm connectors of the LISN (AMN) were resistivity terminated in 50 ohm when not connected to the measuring equipment.

The AC Mains Terminal Continuous disturbance Voltage has been measured with the EUT via AC adapter in a Shielded room.

The EUT via AC adapter was connected to a LISN (AMN).
An overview sweep with peak detection has been performed.

The test results and limit are rounded off to one decimal place, so some differences might be observed.

Detector : QP and CISPR AV
Measurement range : 0.15 MHz – 30 MHz
Test data : APPENDIX
Test result : Pass

SECTION 6: Radiated Spurious Emission

Test Procedure

It was measured based on "11.0 Emissions in non-restricted frequency bands" of "558074 D01 DTS Meas Guidance v03r05".

[For below 1 GHz]

EUT was placed on a platform of nominal size, 1.0 m by 1.5 m, raised 0.8 m above the conducting ground plane. The table is made of Styrofoam and covered with polyvinyl chloride. That has very low permittivity. The Radiated Electric Field Strength has been measured in a Semi Anechoic Chamber with a ground plane.

[For above 1 GHz]

EUT was placed on a urethane platform of nominal size, 0.5 m by 0.5 m, raised 1.5 m above the conducting ground plane.

The Radiated Electric Field Strength has been measured in a Semi Anechoic Chamber with absorbent materials lined on a ground plane.

The height of the measuring antenna varied between 1 and 4 m and EUT was rotated a full revolution in order to obtain the maximum value of the electric field strength.

The measurements were performed for both vertical and horizontal antenna polarization with the Test Receiver, or the Spectrum Analyzer.

The measurements were made with the following detector function of the test receiver and the Spectrum analyzer (in linear mode).

The test was made with the detector (RBW/VBW) in the following table.

When using Spectrum analyzer, the test was made with adjusting span to zero by using peak hold.

Test Antennas are used as below;

Frequency	30 MHz to 200 MHz	200 MHz to 1 GHz	Above 1 GHz
Antenna Type	Biconical	Logperiodic	Horn

In any 100 kHz bandwidth outside the restricted band in which the spread spectrum intentional radiator is operating, the radio frequency power that is produced by the intentional radiator confirmed 20 dB below that in the 100 kHz bandwidth within the band that contains the highest level of the desired power, based on a radiated measurement.

20 dBc was applied to the frequency over the limit of FCC 15.209 / Table 4 of RSS-Gen 8.9(IC) and outside the restricted band of FCC15.205 / Table 6 of RSS-Gen 8.10 (IC).

Frequency	Below 1 GHz	Above 1 GHz		20 dBc
Instrument used	Test Receiver	Spectrum Analyzer		Spectrum Analyzer
Detector	QP	PK	AV *3)	PK
IF Bandwidth	BW 120 kHz	RBW: 1 MHz VBW: 3 MHz	Average Power Method: <u>12.2.5.2</u> RBW: 1 MHz VBW: 3 MHz Detector: Power Averaging (Linear voltage) Trace: 100 traces Duty factor was added to the results.	RBW: 100 kHz VBW: 300kHz
Test Distance	3 m	3.9 m *1) (1 GHz – 13 GHz), 1 m *2) (13 GHz – 26 GHz)		3.9 m *1) (1 GHz – 13 GHz), 1 m *2) (13 GHz – 26 GHz)

*1) Distance Factor: $20 \times \log(3.9 \text{ m} / 3.0 \text{ m}) = 2.28 \text{ dB}$

*2) Distance Factor: $20 \times \log(1.0 \text{ m} / 3.0 \text{ m}) = -9.54 \text{ dB}$

*3) Average Power Measurement was performed based on 6.0 & 12.2.5 of "KDB 558074 D01 DTS Meas Guidance v03r05"

UL Japan, Inc.

Shonan EMC Lab.

1-22-3 Megumigaoka, Hiratsuka-shi, Kanagawa-ken, 259-1220 JAPAN

Telephone : +81 463 50 6400

Facsimile : +81 463 50 6401

- The carrier level and noise levels were confirmed at each position of X, Y and Z axes of EUT to see the position of maximum noise, and the test was made at the position that has the maximum noise.

Combinations of the worst case

(Wireless LAN)

	Frequency Antenna polarization	Carrier *4)	Spurious			
			Below 1 GHz	1 GHz – 2.8 GHz	2.8 GHz – 13 GHz	13 GHz – 26 GHz
SISO	Horizontal	Y	-	Y	Z	X
	Vertical	Y	-	Y	Y	X
MIMO	Horizontal	X	Y	X	Z	X
	Vertical	Y	Z	Y	Y	X

(Bluetooth Low Energy)

Frequency Antenna polarization	Carrier *4)	Spurious			
		Below 1 GHz	1 GHz - 2.8 GHz	2.8 GHz - 13 GHz	13-26 GHz
Horizontal	X	X	X	X	X
Vertical	Y	X	Y	Y	X

*4) with spurious emissions near carrier frequency.

The test results and limit are rounded off to one decimal place, so some differences might be observed.

Measurement range : 30 MHz - 26 GHz
Test data : APPENDIX
Test result : Pass

SECTION 7: Antenna Terminal Conducted Tests

Test Procedure

The tests were made with below setting connected to the antenna port.

Test	Span	RBW	VBW	Sweep time	Detector	Trace	Instrument used
6 dB Bandwidth	50 MHz, 100 MHz or 10 MHz	100 kHz	300 kHz	Auto	Peak	Max Hold	Spectrum Analyzer
99 % Occupied Bandwidth *1)	Enough width to display emission skirts	1 to 5 % of OBW	Three times of RBW	Auto	Sample	Max Hold	Spectrum Analyzer
Maximum Peak Output Power	-	-	-	Auto	Peak/Average *2)	-	Power Meter (Sensor: 160 MHz BW)
Peak Power Density	1.5 times the 6 dB Bandwidth	3 kHz	9.1 kHz	Auto	Peak	Max Hold	Spectrum Analyzer *3)
Conducted Spurious Emission *4)	9 kHz to 150 kHz	200 Hz	620 Hz	Auto	Peak	Max Hold	Spectrum Analyzer
	150 kHz to 30 MHz	10 kHz	30 kHz				

*1) Peak hold was applied as Worst-case measurement.

*2) Reference data

*3) Section 10.2 Method PKPSD (peak PSD) of "KDB 558074 D01 DTS Meas Guidance v03r05".

*4) In the frequency range below 30MHz, RBW was narrowed to separate the noise contents.

Then, wide-band noise near the limit was checked separately, however the noise was not detected as shown in the chart.

The test results and limit are rounded off to two decimals place, so some differences might be observed.

Test data : APPENDIX
Test result : Pass

APPENDIX 1: Test data

Conducted Emission

DATA OF CONDUCTED EMISSION TEST

UL Japan, Inc. Shonan EMC Lab. No.3 Shielded Room
Date : 2016/11/14

Mode : Tx, OFDM, VHT20, 2437 MHz
Power : AC 120 V / 60 Hz
Temp./Humi. : 23 deg.C / 45 %RH

Remarks : MIMO

Limit1 : FCC 15C (15.207) QP
Limit2 : FCC 15C (15.207) AV

Engineer : Kazutaka Takeyama

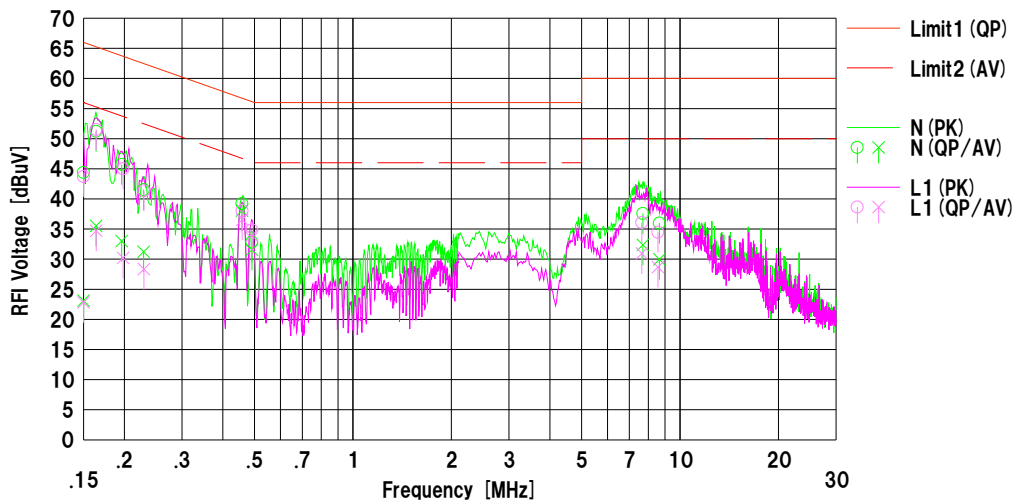

No.	Freq. [MHz]	Reading		C.Fac	Results		Limit		Margin		Phase	Comment
		<QP> [dBuV]	<AV> [dBuV]		[dB]	<QP> [dBuV]	<AV> [dBuV]	<QP> [dBuV]	<AV> [dBuV]	<QP> [dB]		
1	0.15000	31.87	10.60	12.51	44.38	23.11	66.00	56.00	21.6	32.8	N	
2	0.16385	38.70	23.00	12.52	51.22	35.52	65.27	55.27	14.0	19.7	N	
3	0.19630	33.20	20.50	12.51	45.71	33.01	63.77	53.77	18.0	20.7	N	
4	0.22910	29.00	18.70	12.53	41.53	31.23	62.48	52.48	20.9	21.2	N	
5	0.45760	26.70	25.50	12.54	39.24	38.04	56.74	46.74	17.5	8.7	N	
6	0.49102	20.30	19.00	12.54	32.84	31.54	56.15	46.15	23.3	14.6	N	
7	7.70034	24.20	19.00	13.37	37.57	32.37	60.00	50.00	22.4	17.6	N	
8	8.64423	22.50	16.50	13.48	35.98	29.98	60.00	50.00	24.0	20.0	N	
9	0.15000	31.20	10.30	12.51	43.71	22.81	66.00	56.00	22.2	33.1	L1	
10	0.16400	39.00	22.20	12.52	51.52	34.72	65.26	55.26	13.7	20.5	L1	
11	0.19830	32.50	17.70	12.51	45.01	30.21	63.68	53.68	18.6	23.4	L1	
12	0.22950	28.80	15.80	12.53	41.33	28.33	62.47	52.47	21.1	24.1	L1	
13	0.45824	25.50	24.00	12.54	38.04	36.54	56.72	46.72	18.6	10.1	L1	
14	0.49090	22.30	21.40	12.54	34.84	33.94	56.15	46.15	21.3	12.2	L1	
15	7.64400	22.70	17.60	13.36	36.06	30.96	60.00	50.00	23.9	19.0	L1	
16	8.56200	21.00	15.20	13.48	34.48	28.68	60.00	50.00	25.5	21.3	L1	

Calculation: Result [dBuV] = Reading [dBuV] + C.Fac (LISN+Cable+ATT) [dB]
LISN: SLS-02

Conducted Emission

DATA OF CONDUCTED EMISSION TEST

UL Japan, Inc. Shonan EMC Lab. No.3 Shielded Room
Date : 2016/11/10

Mode : Tx BLE 2480 MHz
Power : AC 120 V / 60 Hz
Temp./Humi. : 20 deg.C / 30 %RH

Remarks : -

Limit1 : FCC 15C (15.207) QP
Limit2 : FCC 15C (15.207) AV

Engineer : Kazutaka Takeyama

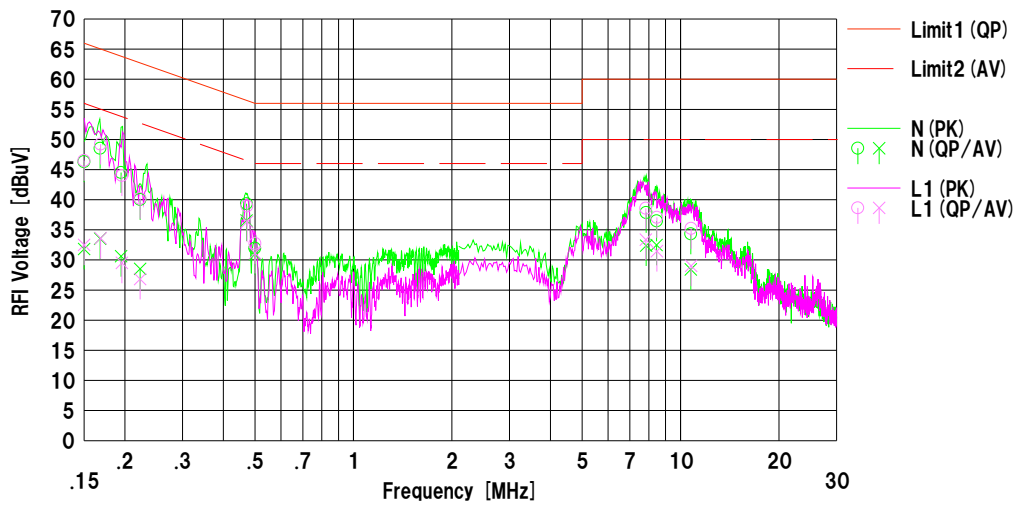

No.	Freq. [MHz]	Reading		C.Fac	Results		Limit		Margin		Phase	Comment
		<QP>	<AV>		<QP>	<AV>	<QP>	<AV>	<QP>	<AV>		
		[dBuV]	[dBuV]		[dB]	[dBuV]	[dBuV]	[dBuV]	[dBuV]	[dB]		
1	0.15000	33.80	19.30	12.51	46.31	31.81	66.00	56.00	19.6	24.1	N	
2	0.16790	36.00	21.00	12.52	48.52	33.52	65.06	55.06	16.5	21.5	N	
3	0.19470	32.00	18.10	12.51	44.51	30.61	63.83	53.83	19.3	23.2	N	
4	0.22270	27.50	16.00	12.52	40.02	28.52	62.72	52.72	22.7	24.2	N	
5	0.47100	26.80	24.00	12.54	39.34	36.54	56.50	46.50	17.1	9.9	N	
6	0.49978	19.40	18.40	12.54	31.94	30.94	56.00	46.00	24.0	15.0	N	
7	7.84700	24.50	19.00	13.38	37.88	32.38	60.00	50.00	22.1	17.6	N	
8	8.45343	23.00	19.00	13.47	36.47	32.47	60.00	50.00	23.5	17.5	N	
9	10.75398	20.60	14.70	13.73	34.33	28.43	60.00	50.00	25.6	21.5	N	
10	0.15000	34.00	20.00	12.51	46.51	32.51	66.00	56.00	19.4	23.4	L1	
11	0.16855	36.70	21.10	12.52	49.22	33.62	65.03	55.03	15.8	21.4	L1	
12	0.19594	31.50	17.00	12.51	44.01	29.51	63.78	53.78	19.7	24.2	L1	
13	0.22280	27.70	14.30	12.52	40.22	26.82	62.71	52.71	22.4	25.8	L1	
14	0.47255	26.40	23.80	12.54	38.94	36.34	56.47	46.47	17.5	10.1	L1	
15	0.50010	20.20	18.60	12.54	32.74	31.14	56.00	46.00	23.2	14.8	L1	
16	7.82976	25.20	20.00	13.38	38.58	33.38	60.00	50.00	21.4	16.6	L1	
17	8.46300	23.60	18.00	13.47	37.07	31.47	60.00	50.00	22.9	18.5	L1	
18	10.77998	21.50	15.30	13.73	35.23	29.03	60.00	50.00	24.7	20.9	L1	

Calculation: Result [dBuV] = Reading [dBuV] + C.Fac (LISN+Cable+ATT) [dB]
LISN: SLS-02

Conducted Emission

Test place	Shonan EMC Lab. No.3 Shielded Room
Report No.	11334871S-A-R1
Date	November 10, 2016
Temperature / Humidity	20 deg. C / 30 % RH
Engineer	Kazutaka Takeyama
Mode	Tx BT LE

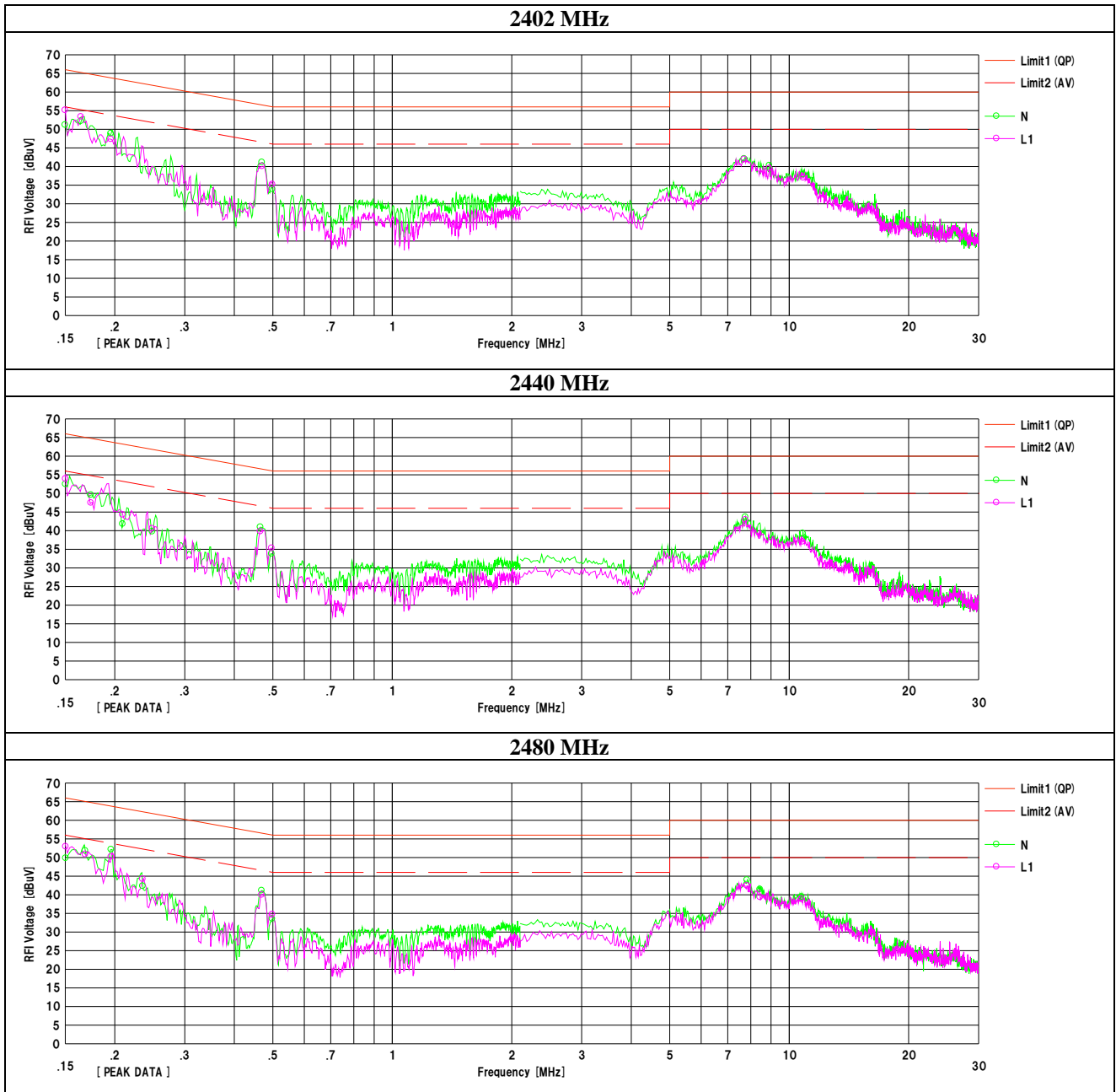

Y scale [dBuV]

Chart — N — L

UL Japan, Inc.

Shonan EMC Lab.

1-22-3 Megumigaoka, Hiratsuka-shi, Kanagawa-ken, 259-1220 JAPAN

Telephone : +81 463 50 6400

Facsimile : +81 463 50 6401

6 dB Bandwidth

Test place	Shonan EMC Lab. No.1 Measurement Room		
Report No.	11334871S-A-R1		
Date	October 21, 2016	November 2, 2016	November 4, 2016
Temperature / Humidity	26 deg. C / 45 % RH	24 deg. C / 36 % RH	24 deg. C / 40 % RH
Engineer	Kenichi Adachi	Kenichi Adachi	Kenichi Adachi
Mode	Tx, WLAN (*WLAN: Wireless LAN)		

(worst antenna port)

Mode	Frequency [MHz]	6 dB Bandwidth [MHz]	Limit [kHz]
11b	2412	9.063	> 500
	2437	9.299	> 500
	2462	9.070	> 500
	2467	8.799	> 500
	2472	8.447	> 500
11g	2412	16.479	> 500
	2437	16.473	> 500
	2462	16.474	> 500
	2467	16.483	> 500
	2472	16.479	> 500
11n-20 SISO	2412	17.736	> 500
	2437	17.753	> 500
	2462	17.714	> 500
	2467	17.744	> 500
	2472	17.244	> 500
OFDM, VHT20 SISO	2412	17.724	> 500
	2437	17.691	> 500
	2462	17.743	> 500
	2467	17.738	> 500
	2472	17.215	> 500
11n-40 SISO	2422	36.509	> 500
	2437	36.486	> 500
	2452	36.467	> 500
	2457	36.516	> 500
	2462	36.484	> 500
OFDM, VHT40 SISO	2422	36.525	> 500
	2437	36.530	> 500
	2452	36.535	> 500
	2457	36.474	> 500
	2462	36.502	> 500

(worst antenna port)

Mode	Frequency [MHz]	6 dB Bandwidth [MHz]	Limit [kHz]
11n-20 MIMO	2412	17.754	> 500
	2437	17.754	> 500
	2462	17.673	> 500
	2467	17.689	> 500
	2472	17.037	> 500
OFDM, VHT20 MIMO	2412	17.756	> 500
	2437	17.718	> 500
	2462	17.721	> 500
	2467	17.733	> 500
	2472	17.150	> 500
11n-40 MIMO	2422	36.460	> 500
	2437	36.481	> 500
	2452	36.490	> 500
	2457	36.498	> 500
	2462	36.482	> 500
OFDM, VHT40 MIMO	2422	36.484	> 500
	2437	36.478	> 500
	2452	36.465	> 500
	2457	36.470	> 500
	2462	36.494	> 500

UL Japan, Inc.

Shonan EMC Lab.

1-22-3 Megumigaoka, Hiratsuka-shi, Kanagawa-ken, 259-1220 JAPAN

Telephone : +81 463 50 6400

Facsimile : +81 463 50 6401

6 dB Bandwidth

11b

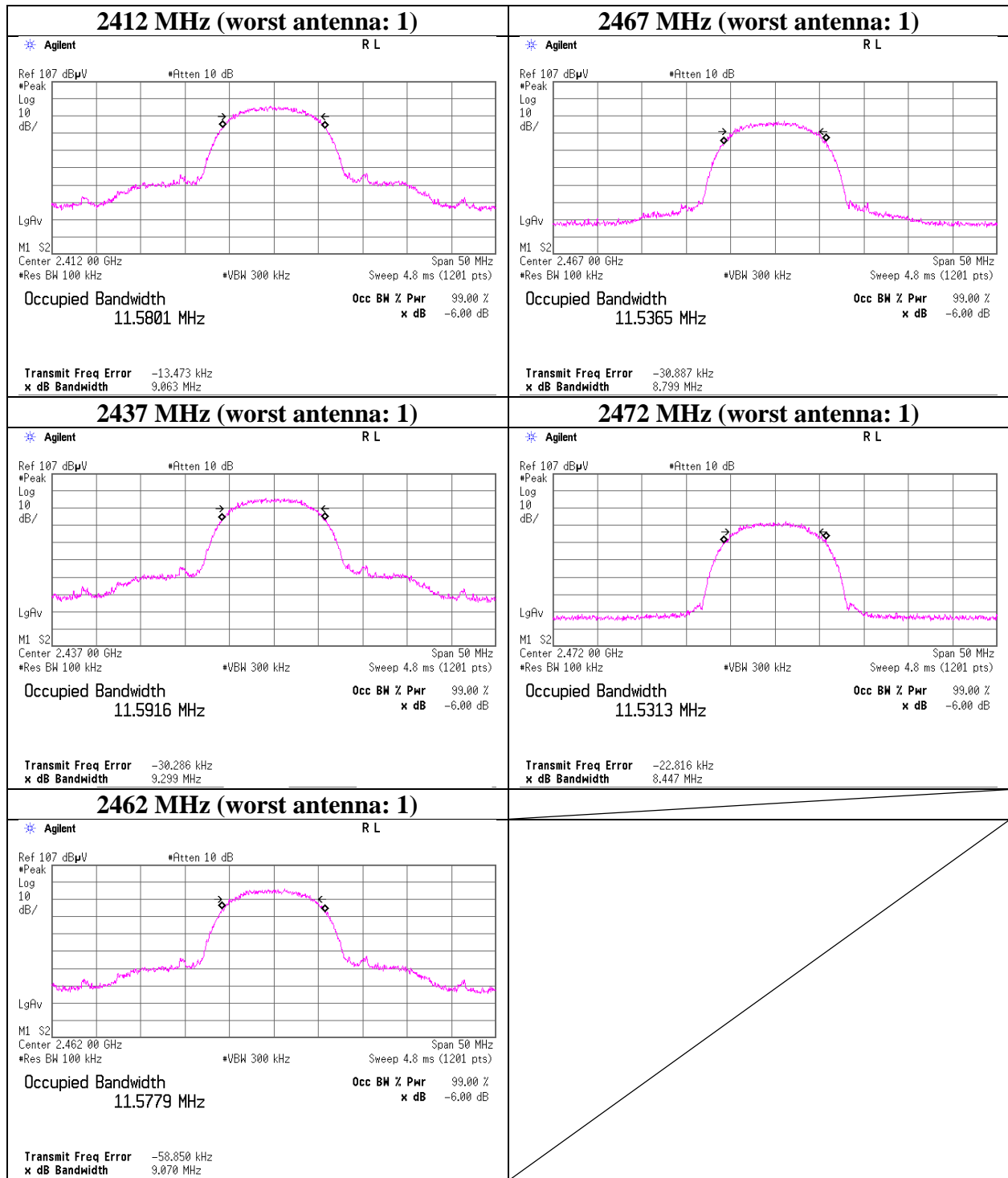

6 dB Bandwidth

11g

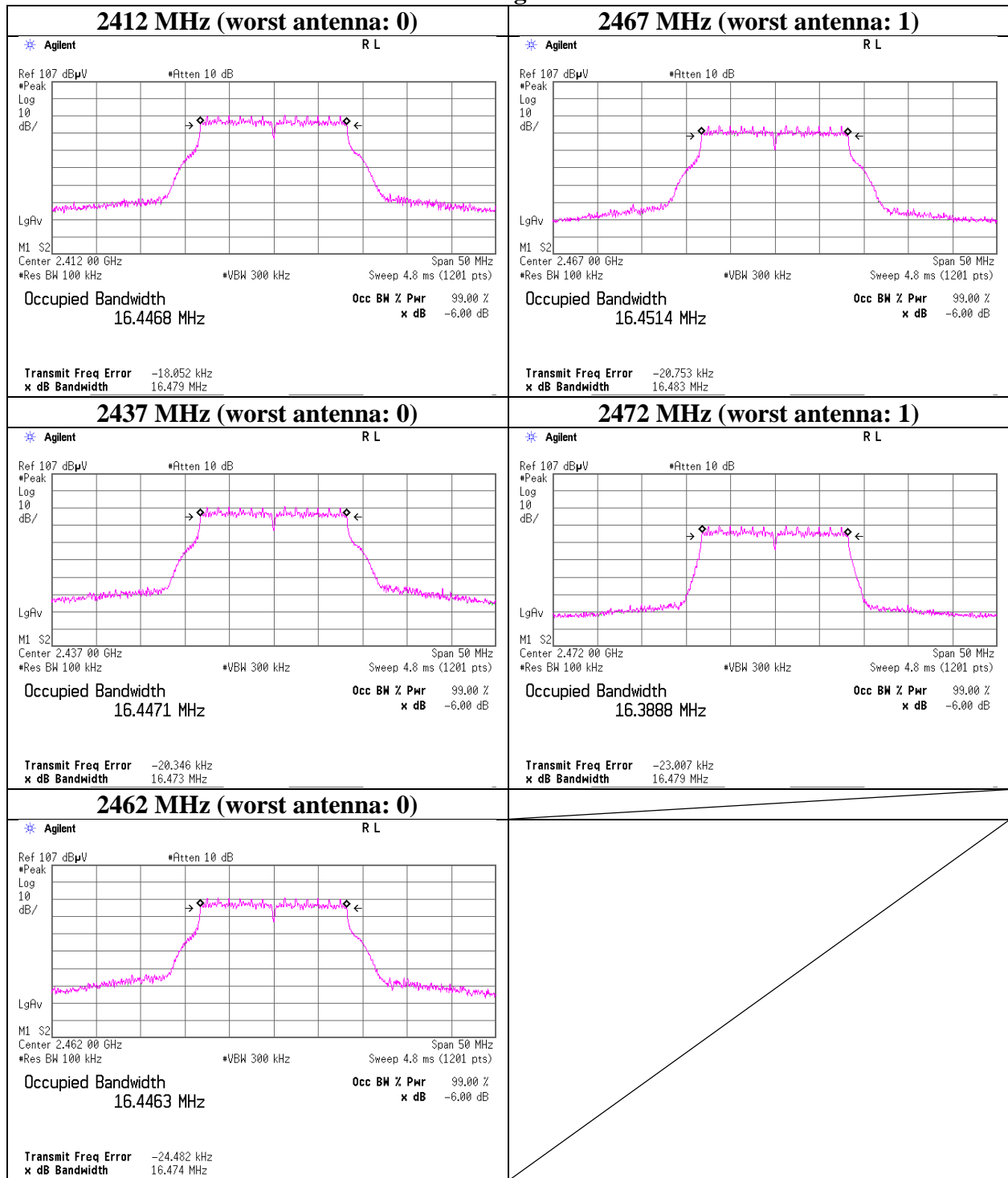

6 dB Bandwidth

11n-20, SISO

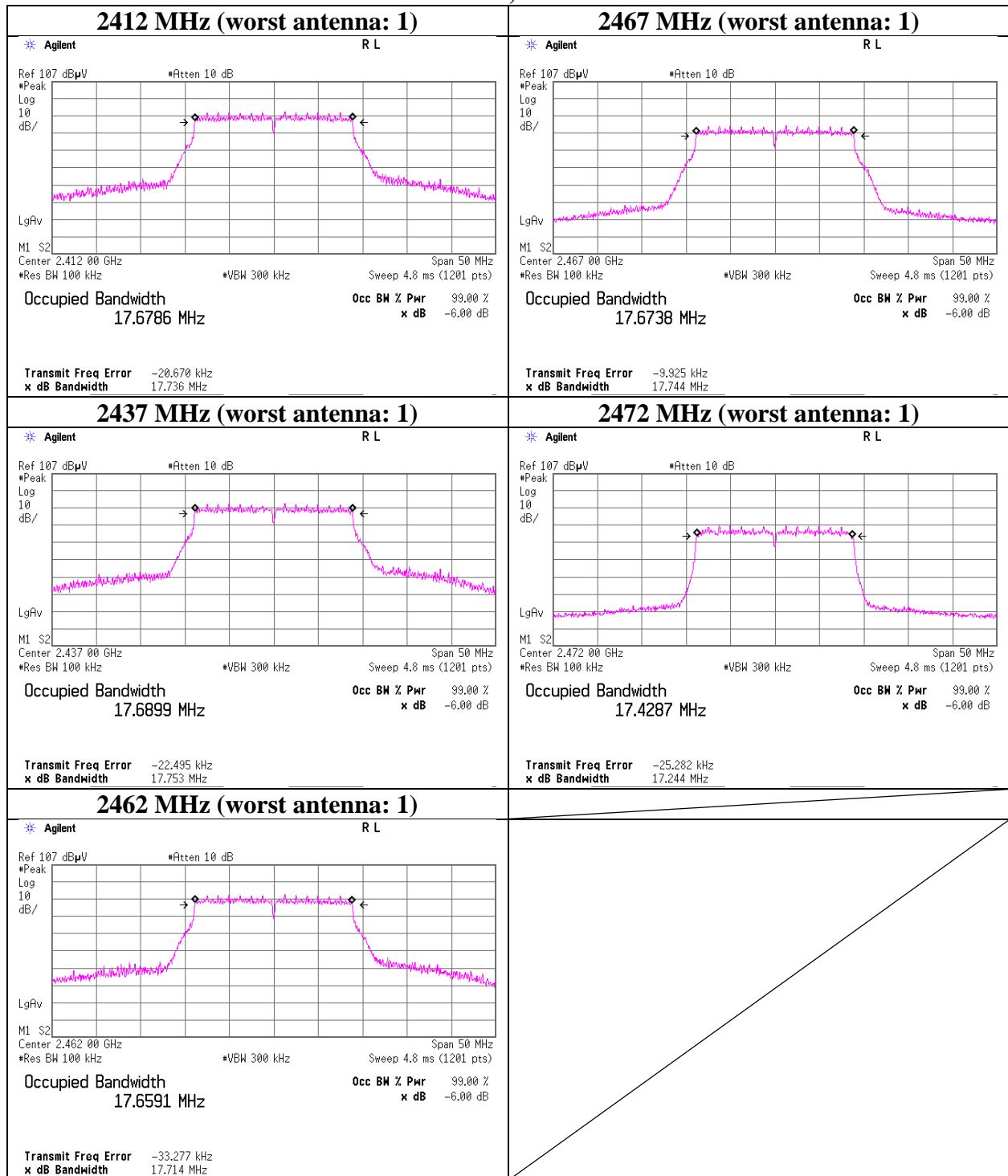

6 dB Bandwidth

OFDM, VHT20, SISO

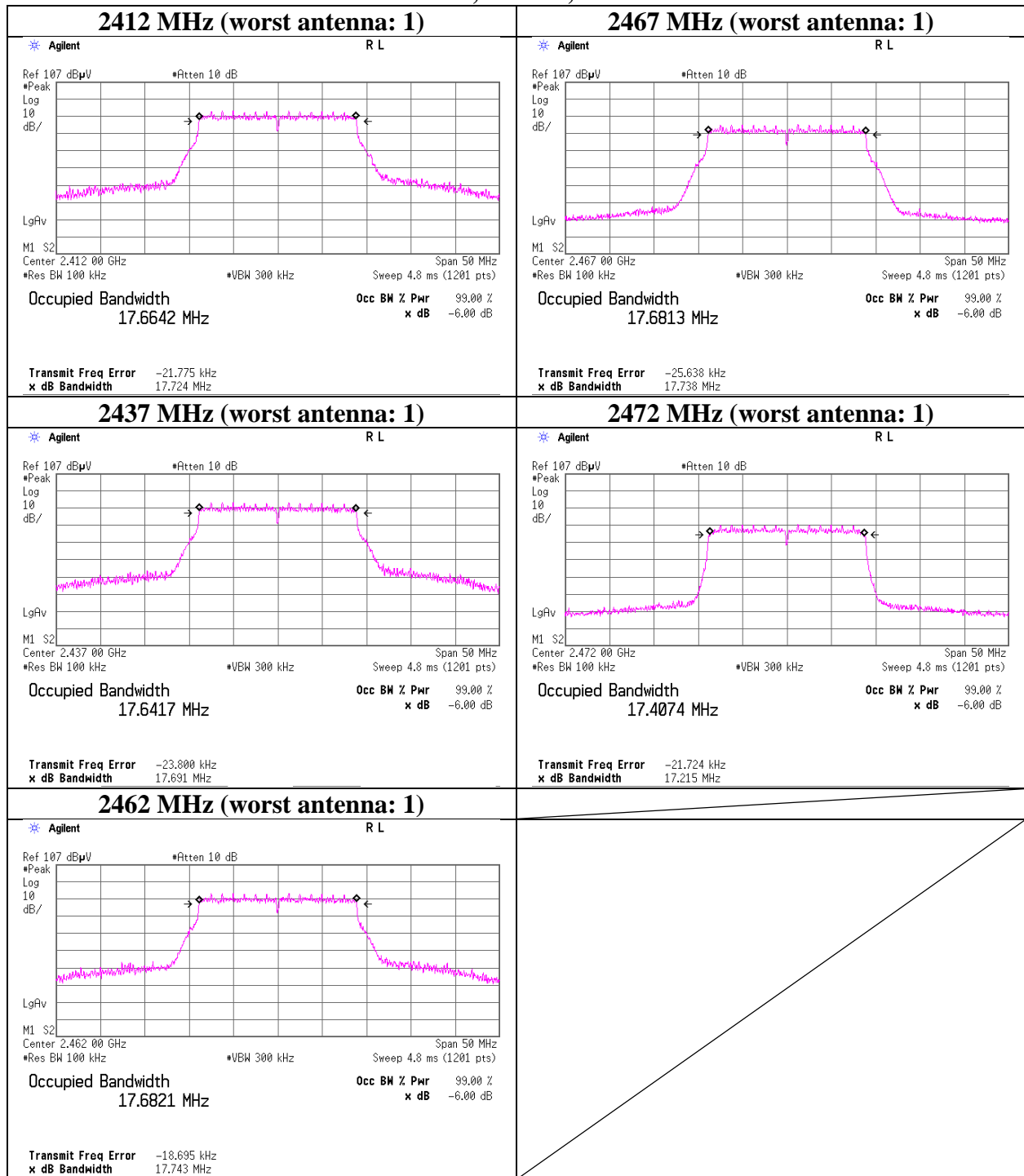

6 dB Bandwidth

11n-40, SISO

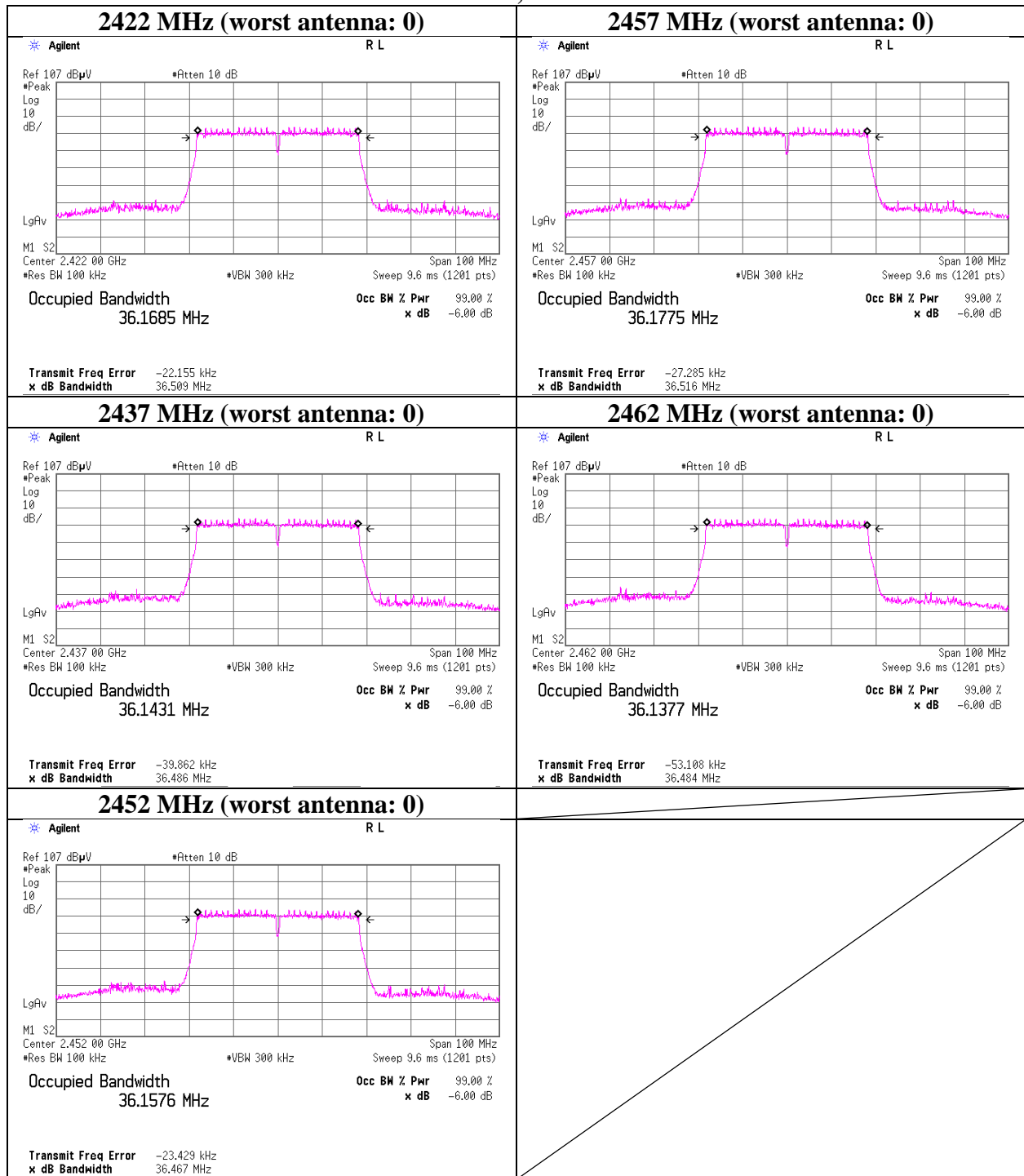

UL Japan, Inc.

Shonan EMC Lab.

1-22-3 Megumigaoka, Hiratsuka-shi, Kanagawa-ken, 259-1220 JAPAN

Telephone : +81 463 50 6400

Facsimile : +81 463 50 6401

6 dB Bandwidth

OFDM, VHT40, SISO

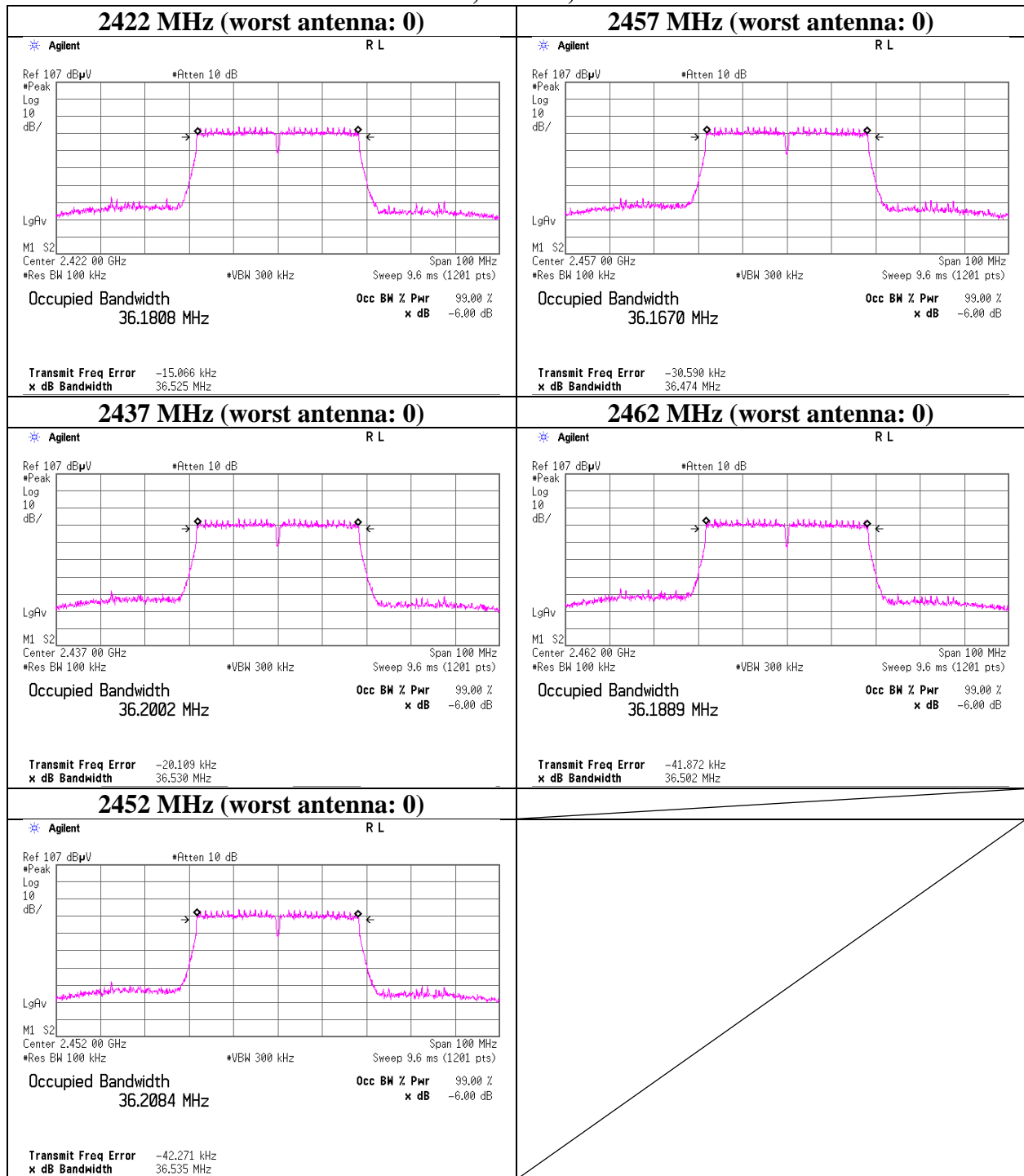

6 dB Bandwidth

11n-20, MIMO

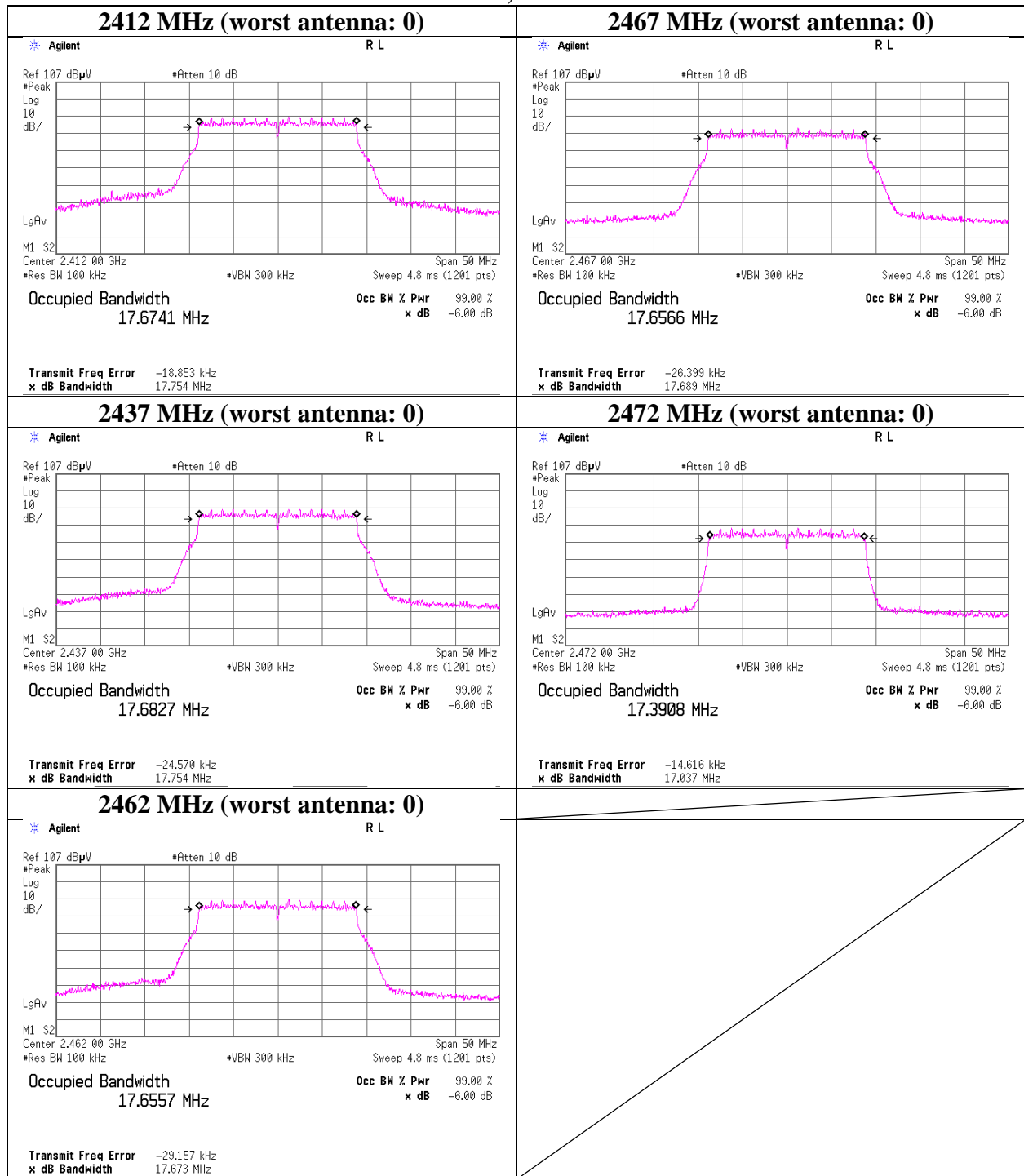

UL Japan, Inc.

Shonan EMC Lab.

1-22-3 Megumigaoka, Hiratsuka-shi, Kanagawa-ken, 259-1220 JAPAN

Telephone : +81 463 50 6400

Facsimile : +81 463 50 6401

6 dB Bandwidth

OFDM, VHT20, MIMO

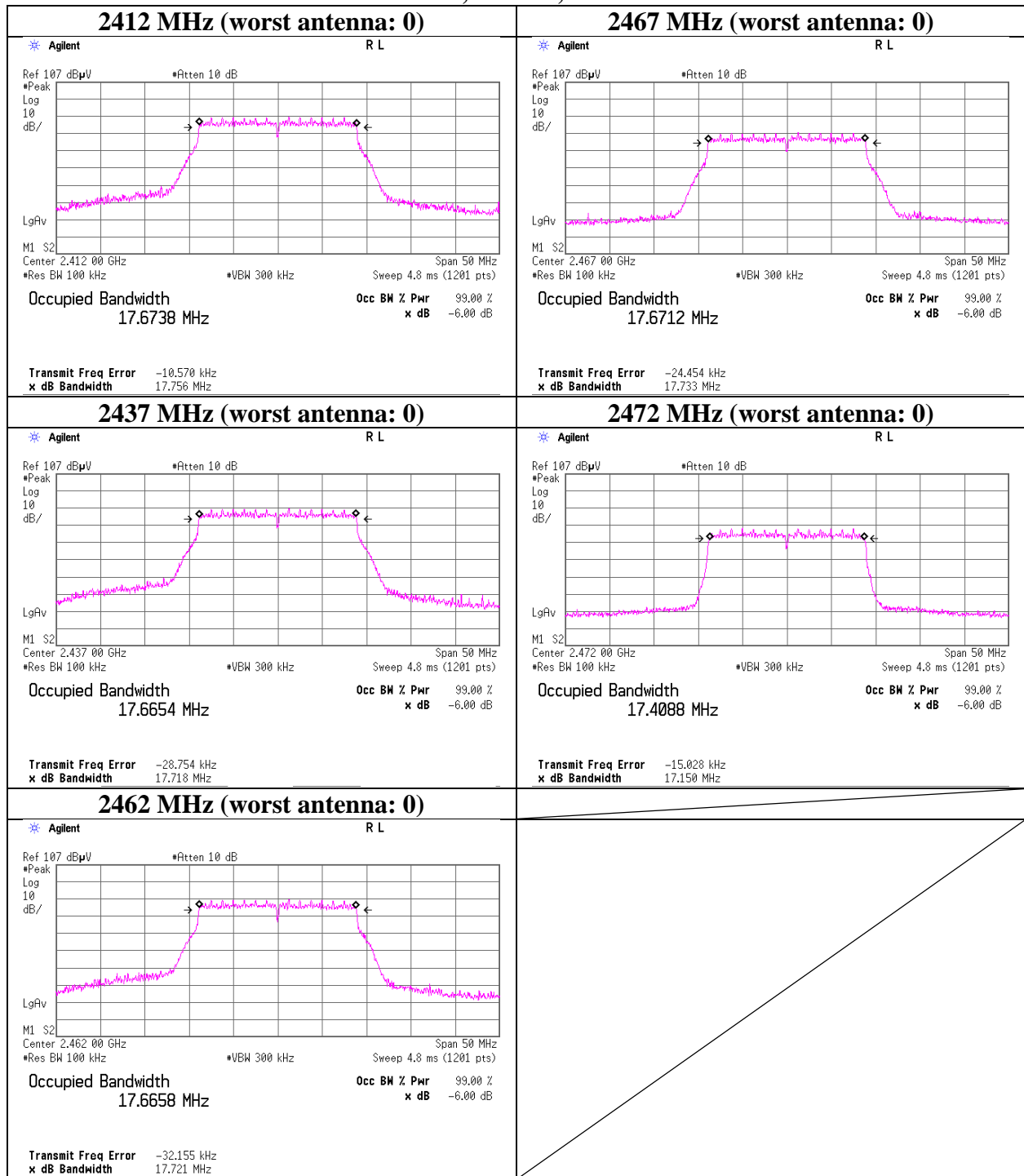

UL Japan, Inc.

Shonan EMC Lab.

1-22-3 Megumigaoka, Hiratsuka-shi, Kanagawa-ken, 259-1220 JAPAN

Telephone : +81 463 50 6400

Facsimile : +81 463 50 6401

6 dB Bandwidth

11n-40, MIMO

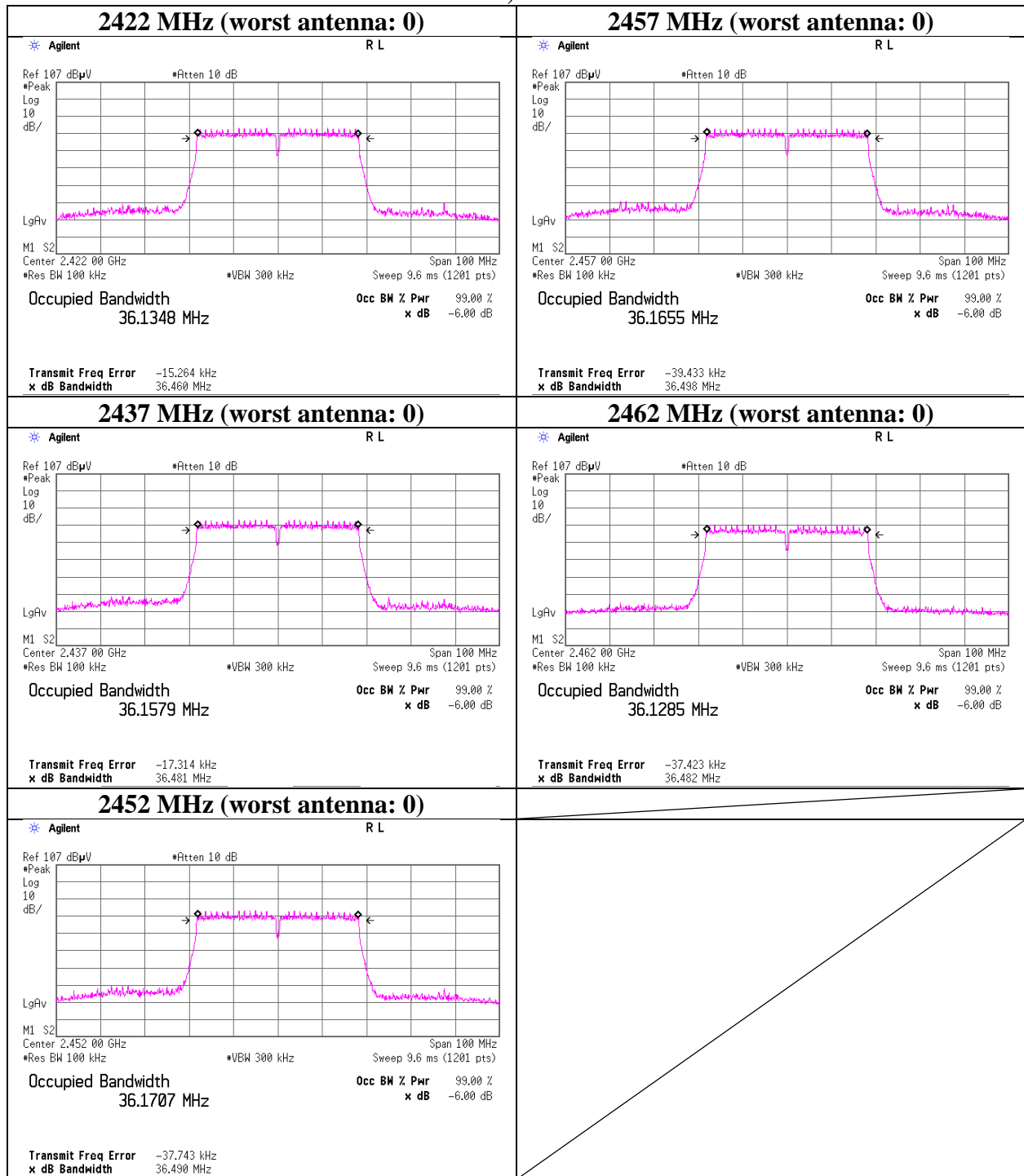

6 dB Bandwidth

OFDM, VHT40, MIMO

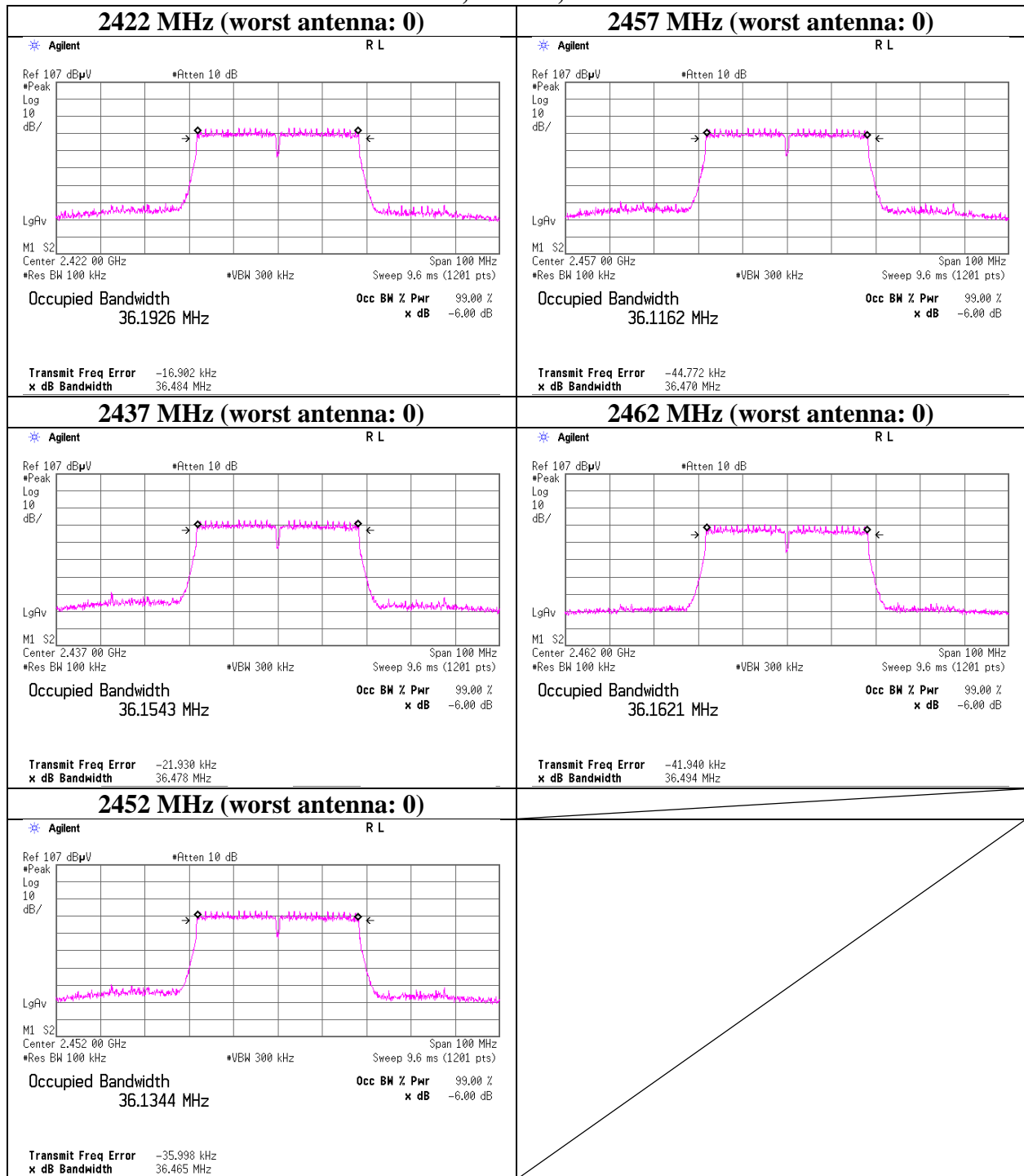

UL Japan, Inc.

Shonan EMC Lab.

1-22-3 Megumigaoka, Hiratsuka-shi, Kanagawa-ken, 259-1220 JAPAN

Telephone : +81 463 50 6400

Facsimile : +81 463 50 6401

6 dB Bandwidth

Test place	Shonan EMC Lab. No.1 Measurement Room
Report No.	11334871S-A-R1
Date	November 11, 2016
Temperature / Humidity	25 deg. C / 33 % RH
Engineer	Hikaru Shirasawa
Mode	Tx BT LE

Mode	Frequency [MHz]	6 dB Bandwidth [MHz]	Limit [kHz]
BT LE	2402	0.729	> 500
	2440	0.735	> 500
	2480	0.729	> 500

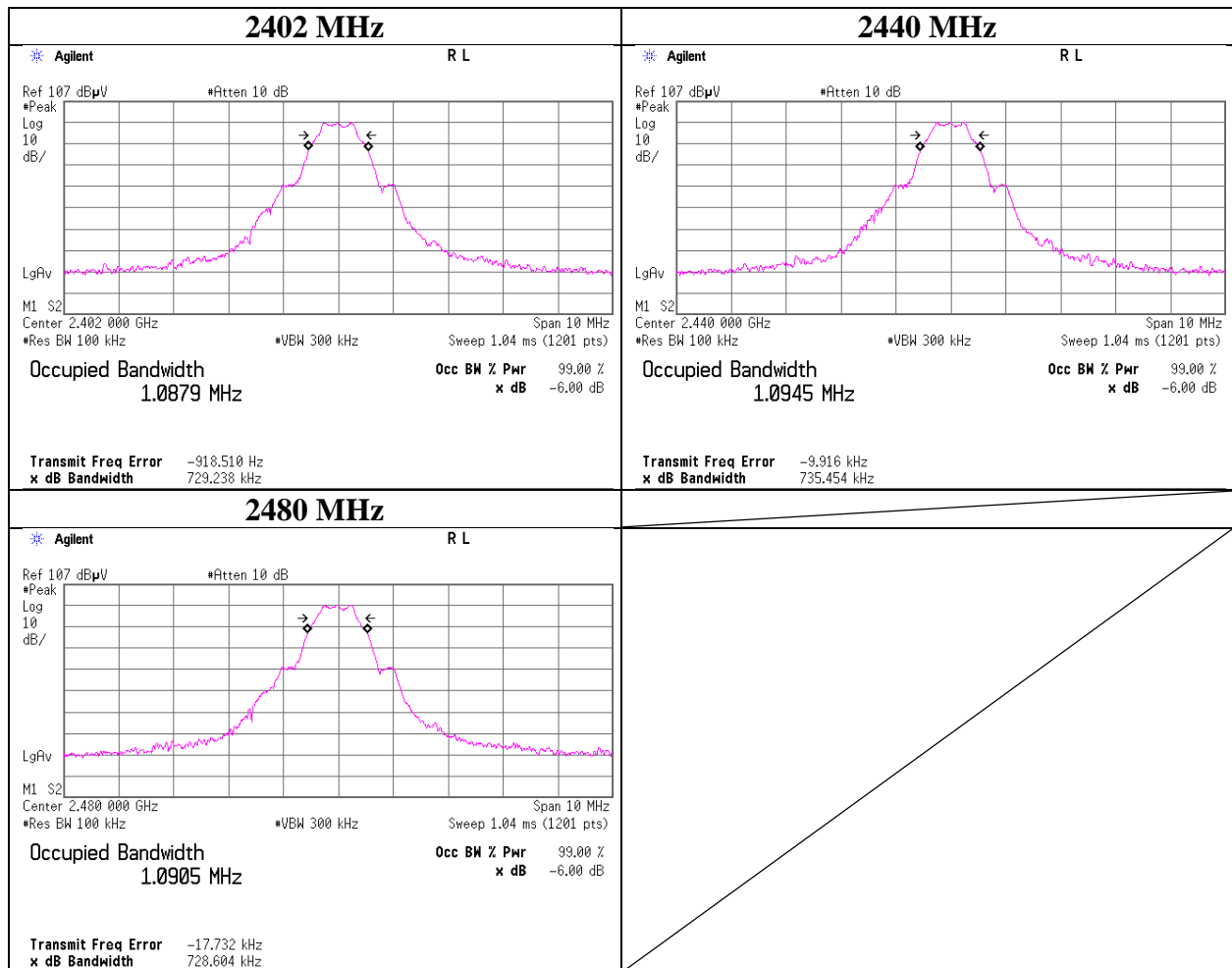

Maximum Peak Output Power

Test place : Shonan EMC Lab. No.1 Measurement Room
Report No. : 11334871S-A-R1
Date : October 21, 2016
Temperature / Humidity : 26 deg. C / 45 %RH
Engineer : Kenichi Adachi
Mode : Tx 11b

Antenna 1

Freq. [MHz]	Reading (Peak) [dBm]	Cable Loss [dB]	Atten. Loss [dB]	Result		Limit		Margin [dB]
				[dBm]	[mW]	[dBm]	[mW]	
2412	-1.02	2.04	20.22	21.24	133.05	30.00	1000	8.76
2437	-0.93	2.04	20.23	21.34	136.14	30.00	1000	8.66
2462	-0.99	2.05	20.23	21.29	134.59	30.00	1000	8.71
2467	-9.89	2.05	20.23	12.39	17.34	30.00	1000	17.61
2472	-14.81	2.05	20.23	7.47	5.58	30.00	1000	22.53

Sample Calculation:

Result = Reading + Cable Loss (including the cable(s) customer supplied) + Attenuator Loss

*The equipment and cables were not used for factor 0 dB of the data sheets.

Antenna: 0, 2437 MHz

Rate [Mbps]	Reading (Peak) [dBm]	Remark
1	-1.93	
2	-1.82	
5.5	-1.78	
11	-1.65	

Antenna: 1, 2437 MHz

Rate [Mbps]	Reading (Peak) [dBm]	Remark
1	-1.41	
2	-1.16	
5.5	-1.22	
11	-0.93	*

*: Worst Rate

All comparison were carried out on same frequency and measurement factors.

* Difference between worst rate check data and formal test result is due to the different test condition.

Maximum Peak Output Power

Test place : Shonan EMC Lab. No.1 Measurement Room
Report No. : 11334871S-A-R1
Date : October 21, 2016
Temperature / Humidity : 26 deg. C / 45 %RH
Engineer : Kenichi Adachi
Mode : Tx 11g

Antenna 0 (2412 to 2462 MHz), Antenna 1 (2467 to 2472 MHz)

Freq. [MHz]	Reading (Peak) [dBm]	Cable Loss [dB]	Atten. Loss [dB]	Result		Limit		Margin [dB]
				[dBm]	[mW]	[dBm]	[mW]	
2412	1.67	2.11	20.22	24.00	251.19	30.00	1000	6.00
2437	1.57	2.11	20.23	23.91	246.04	30.00	1000	6.09
2462	1.59	2.12	20.23	23.94	247.74	30.00	1000	6.06
2467	-2.87	2.05	20.23	19.41	87.30	30.00	1000	10.59
2472	-8.86	2.05	20.23	13.42	21.98	30.00	1000	16.58

Sample Calculation:

Result = Reading + Cable Loss (including the cable(s) customer supplied) + Attenuator Loss

*The equipment and cables were not used for factor 0 dB of the data sheets.

Antenna: 0, 2437 MHz

Rate [Mbps]	Reading (Peak) [dBm]	Remark
6	0.42	
9	0.55	
12	0.21	
18	0.31	
24	1.20	
36	1.51	
48	1.57	*
54	0.91	

Antenna: 1, 2437 MHz

Rate [Mbps]	Reading (Peak) [dBm]	Remark
6	0.61	
9	0.58	
12	0.36	
18	0.45	
24	0.71	
36	0.81	
48	1.30	
54	0.64	

Antenna: 0, 2467 MHz

Rate [Mbps]	Reading (Peak) [dBm]	Remark
6	-5.98	
9	-5.93	
12	-6.25	
18	-6.16	
24	-4.20	
36	-4.11	
48	-3.64	
54	-4.44	

Antenna: 1, 2467 MHz

Rate [Mbps]	Reading (Peak) [dBm]	Remark
6	-5.00	
9	-5.15	
12	-5.31	
18	-5.22	
24	-3.67	
36	-2.88	
48	-2.87	*
54	-3.73	

*: Worst Rate

All comparison were carried out on same frequency and measurement factors.

* Difference between worst rate check data and formal test result is due to the different test condition.

*Power settings between 2412 MHz to 2462 MHz and 2467 MHz to 2472 MHz are different so the worst rate check was applied on 2437 MHz and 2467 MHz.

Maximum Peak Output Power

Test place Shonan EMC Lab. No.1 Measurement Room
Report No. 11334871S-A-R1
Date October 21, 2016
Temperature / Humidity 26 deg. C / 45 %RH
Engineer Kenichi Adachi
Mode Tx 11n-20, SISO

Antenna 1

Freq. [MHz]	Reading (Peak) [dBm]	Cable Loss [dB]	Atten. Loss [dB]	Result		Limit		Margin [dB]
				[dBm]	[mW]	[dBm]	[mW]	
2412	2.57	2.04	20.22	24.83	304.09	30.00	1000	5.17
2437	2.55	2.04	20.23	24.82	303.39	30.00	1000	5.18
2462	2.51	2.05	20.23	24.79	301.30	30.00	1000	5.21
2467	-3.27	2.05	20.23	19.01	79.62	30.00	1000	10.99
2472	-7.95	2.05	20.23	14.33	27.10	30.00	1000	15.67

Sample Calculation:

Result = Reading + Cable Loss (including the cable(s) customer supplied) + Attenuator Loss

*The equipment and cables were not used for factor 0 dB of the data sheets.

Antenna: 0, 2437 MHz

MCS	Reading (Peak) [dBm]	Remark
0	0.86	
1	0.77	
2	0.72	
3	2.25	
4	2.12	
5	1.92	
6	2.10	
7	1.57	

Antenna: 1, 2437 MHz

MCS	Reading (Peak) [dBm]	Remark
0	1.10	
1	0.51	
2	0.60	
3	2.55	*
4	1.70	
5	1.65	
6	1.78	
7	1.29	

Antenna: 0, 2467 MHz

MCS	Reading (Peak) [dBm]	Remark
0	-6.48	
1	-6.68	
2	-6.18	
3	-3.81	
4	-3.89	
5	-3.95	
6	-3.97	
7	-4.08	

Antenna: 1, 2467 MHz

MCS	Reading (Peak) [dBm]	Remark
0	-5.28	
1	-5.20	
2	-5.87	
3	-3.27	*
4	-3.46	
5	-3.41	
6	-3.49	
7	-3.48	

*: Worst Rate

All comparison were carried out on same frequency and measurement factors.

* Difference between worst rate check data and formal test result is due to the different test condition.

*Power settings between 2412 MHz to 2462 MHz and 2467 MHz to 2472 MHz are different so the worst rate check was applied on 2437 MHz and 2467 MHz.

Maximum Peak Output Power

Test place : Shonan EMC Lab. No.1 Measurement Room
Report No. : 11334871S-A-R1
Date : October 21, 2016
Temperature / Humidity : 26 deg. C / 45 %RH
Engineer : Kenichi Adachi
Mode : Tx OFDM, VHT20, SISO

Antenna 1

Freq. [MHz]	Reading (Peak) [dBm]	Cable Loss [dB]	Atten. Loss [dB]	Result		Limit		Margin [dB]
				[dBm]	[mW]	[dBm]	[mW]	
2412	2.50	2.04	20.22	24.76	299.23	30.00	1000	5.24
2437	2.45	2.04	20.23	24.72	296.48	30.00	1000	5.28
2462	2.38	2.05	20.23	24.66	292.42	30.00	1000	5.34
2467	-3.49	2.05	20.23	18.79	75.68	30.00	1000	11.21
2472	-8.15	2.05	20.23	14.13	25.88	30.00	1000	15.87

Sample Calculation:

Result = Reading + Cable Loss (including the cable(s) customer supplied) + Attenuator Loss

*The equipment and cables were not used for factor 0 dB of the data sheets.

Antenna: 0, 2437 MHz

MCS	Reading (Peak) [dBm]	Remark
0	0.49	
1	0.50	
2	0.46	
3	2.32	
4	1.98	
5	2.06	
6	1.87	
7	1.54	
8	0.85	

Antenna: 1, 2437 MHz

MCS	Reading (Peak) [dBm]	Remark
0	0.71	
1	0.60	
2	0.62	
3	2.45	*
4	1.67	
5	1.87	
6	1.74	
7	1.08	
8	0.29	

Antenna: 0, 2467 MHz

MCS	Reading (Peak) [dBm]	Remark
0	-6.77	
1	-6.87	
2	-7.07	
3	-4.04	
4	-4.11	
5	-4.64	
6	-4.41	
7	-4.41	
8	-4.86	

Antenna: 1, 2467 MHz

MCS	Reading (Peak) [dBm]	Remark
0	-6.19	
1	-6.10	
2	-6.25	
3	-3.49	*
4	-3.97	
5	-3.82	
6	-4.06	
7	-3.87	
8	-4.02	

*: Worst Rate

All comparison were carried out on same frequency and measurement factors.

* Difference between worst rate check data and formal test result is due to the different test condition.

*Power settings between 2412 MHz to 2462 MHz and 2467 MHz to 2472 MHz are different so the worst rate check was applied on 2437 MHz and 2467 MHz.

UL Japan, Inc.

Shonan EMC Lab.

1-22-3 Megumigaoka, Hiratsuka-shi, Kanagawa-ken, 259-1220 JAPAN

Telephone : +81 463 50 6400

Facsimile : +81 463 50 6401

Maximum Peak Output Power

Test place Shonan EMC Lab. No.1 Measurement Room
Report No. 11334871S-A-R1
Date October 21, 2016
Temperature / Humidity 26 deg. C / 45 %RH
Engineer Kenichi Adachi
Mode Tx 11n-40, SISO

Antenna 0

Freq. [MHz]	Reading [dBm]	Cable Loss [dB]	Atten. Loss [dB]	Result		Limit		Margin [dB]
				[dBm]	[mW]	[dBm]	[mW]	
2422	-2.70	2.11	20.23	19.64	92.04	30.00	1000	10.36
2437	-2.58	2.11	20.23	19.76	94.62	30.00	1000	10.24
2452	-2.44	2.11	20.23	19.90	97.72	30.00	1000	10.10
2457	-2.73	2.11	20.23	19.61	91.41	30.00	1000	10.39
2462	-2.62	2.12	20.23	19.73	93.97	30.00	1000	10.27

Sample Calculation:

Result = Reading + Cable Loss (including the cable(s) customer supplied) + Attenuator Loss

*The equipment and cables were not used for factor 0 dB of the data sheets.

Antenna: 0, 2437 MHz

MCS	Reading [dBm]	Remark
0	-3.29	
1	-3.45	
2	-3.70	
3	-2.58	*
4	-2.98	
5	-2.81	
6	-2.83	
7	-3.24	

Antenna: 1, 2437 MHz

MCS	Reading [dBm]	Remark
0	-3.65	
1	-3.92	
2	-3.89	
3	-2.61	
4	-3.04	
5	-3.03	
6	-3.10	
7	-3.90	

*: Worst Rate

All comparison were carried out on same frequency and measurement factors.

Maximum Peak Output Power

Test place : Shonan EMC Lab. No.1 Measurement Room
Report No. : 11334871S-A-R1
Date : October 21, 2016
Temperature / Humidity : 26 deg. C / 45 % RH
Engineer : Kenichi Adachi
Mode : Tx OFDM, VHT40, SISO

Antenna 0

Freq. [MHz]	Reading [dBm]	Cable Loss [dB]	Atten. Loss [dB]	Result		Limit		Margin [dB]
				[dBm]	[mW]	[dBm]	[mW]	
2422	-2.71	2.11	20.23	19.63	91.83	30.00	1000	10.37
2437	-2.68	2.11	20.23	19.66	92.47	30.00	1000	10.34
2452	-2.80	2.11	20.23	19.54	89.95	30.00	1000	10.46
2457	-2.79	2.11	20.23	19.55	90.16	30.00	1000	10.45
2462	-2.66	2.12	20.23	19.69	93.11	30.00	1000	10.31

Sample Calculation:

Result = Reading + Cable Loss (including the cable(s) customer supplied) + Attenuator Loss

*The equipment and cables were not used for factor 0 dB of the data sheets.

Antenna: 0, 2437 MHz

MCS	Reading [dBm]	Remark
0	-3.59	
1	-3.97	
2	-4.05	
3	-2.68	*
4	-2.79	
5	-2.93	
6	-2.80	
7	-3.30	
8	-3.84	
9	-3.96	

Antenna: 1, 2437 MHz

MCS	Reading [dBm]	Remark
0	-3.92	
1	-3.95	
2	-4.03	
3	-2.74	
4	-2.80	
5	-2.85	
6	-3.04	
7	-3.78	
8	-4.54	
9	-4.19	

*: Worst Rate

All comparison were carried out on same frequency and measurement factors.

Maximum Peak Output Power

Test place : Shonan EMC Lab. No.1 Measurement Room
Report No. : 11334871S-A-R1
Date : October 31, 2016
Temperature / Humidity : 24 deg. C / 44 % RH
Engineer : Kenichi Adachi
Mode : Tx 11n-20, MIMO

Antenna 0 + Antenna 1

Ch	Freq. [MHz]	Result Ant 0 [mW]	Result Ant 1 [mW]	-	Result Ant 0 + Ant 1		Limit		Margin [dB]
					[dBm]	[mW]	[dBm]	[mW]	
Low	2412.0	179.18	138.04	-	25.01	317.22	30.00	1000	4.99
Mid	2437.0	179.18	140.93	-	25.05	320.11	30.00	1000	4.95
High1	2462.0	172.31	141.58	-	24.97	313.89	30.00	1000	5.03
High2	2467.0	36.72	30.41	-	18.27	67.13	30.00	1000	11.73
High3	2472.0	14.13	12.82	-	14.31	26.95	30.00	1000	15.69

Antenna 0

(* P/M: Power Meter with power sensor)

Ch	Freq. [MHz]	P/M (Peak) Reading [dBm]	Cable Loss [dB]	Atten. Loss [dB]	Result		Limit		Margin [dB]
					[dBm]	[mW]	[dBm]	[mW]	
Low	2412.0	0.88	1.43	20.22	22.53	179.18	30.00	1000	7.47
Mid	2437.0	0.86	1.44	20.23	22.53	179.18	30.00	1000	7.47
High1	2462.0	0.69	1.44	20.23	22.36	172.31	30.00	1000	7.64
High2	2467.0	-6.02	1.44	20.23	15.65	36.72	30.00	1000	14.35
High3	2472.0	-10.17	1.44	20.23	11.50	14.13	30.00	1000	18.50

Antenna 1

(* P/M: Power Meter with power sensor)

Ch	Freq. [MHz]	P/M (Peak) Reading [dBm]	Cable Loss [dB]	Atten. Loss [dB]	Result		Limit		Margin [dB]
					[dBm]	[mW]	[dBm]	[mW]	
Low	2412.0	-0.18	1.36	20.22	21.40	138.04	30.00	1000	8.60
Mid	2437.0	-0.11	1.37	20.23	21.49	140.93	30.00	1000	8.51
High1	2462.0	-0.09	1.37	20.23	21.51	141.58	30.00	1000	8.49
High2	2467.0	-6.77	1.37	20.23	14.83	30.41	30.00	1000	15.17
High3	2472.0	-10.52	1.37	20.23	11.08	12.82	30.00	1000	18.92

Sample Calculation:

Result = Reading + Cable Loss (including the cable(s) customer supplied) + Atten. Loss

[Pre check]

Mode (MCS)	Freq. [MHz]	Reading Antenna 0		Reading Antenna 1		Reading Antenna 0 + 1	
		[dBm]	[mW]	[dBm]	[mW]	[dBm]	[mW]
8	2437.0	-1.27	0.75	-2.03	0.63	1.40	1.38
9	2437.0	-1.34	0.73	-2.35	0.58	1.17	1.31
10	2437.0	-1.31	0.74	-2.61	0.55	1.11	1.29
11	2437.0	0.86	1.22	-0.11	0.97	3.40	2.19
12	2437.0	0.88	1.22	-0.53	0.89	3.24	2.11
13	2437.0	0.79	1.20	-0.36	0.92	3.26	2.12
14	2437.0	0.90	1.23	-0.46	0.90	3.28	2.13
15	2437.0	0.83	1.21	-0.40	0.91	3.26	2.12

Worst

Sample Calculation:

Result = Reading + Cable Loss (including the cable(s) customer supplied) + Attenuator Loss

UL Japan, Inc.

Shonan EMC Lab.

1-22-3 Megumigaoka, Hiratsuka-shi, Kanagawa-ken, 259-1220 JAPAN

Telephone : +81 463 50 6400

Facsimile : +81 463 50 6401

Maximum Peak Output Power

Test place Shonan EMC Lab. No.1 Measurement Room
Report No. 11334871S-A-R1
Date November 2, 2016
Temperature / Humidity 24 deg. C / 36 % RH
Engineer Kenichi Adachi
Mode Tx OFDM, VHT20, MIMO

Antenna 0 + Antenna 1

Ch	Freq. [MHz]	Result Ant 0 [mW]	Result Ant 1 [mW]	-	Result Ant 0 + Ant 1		Limit		Margin [dB]
					[dBm]	[mW]	[dBm]	[mW]	
Low	2412.0	177.54	151.71	-	25.18	329.25	30.00	1000	4.82
Mid	2437.0	176.32	162.93	-	25.31	339.25	30.00	1000	4.69
High1	2462.0	175.11	162.18	-	25.28	337.29	30.00	1000	4.72
High2	2467.0	38.40	35.16	-	18.67	73.56	30.00	1000	11.33
High3	2472.0	14.67	13.96	-	14.57	28.63	30.00	1000	15.43

Antenna 0

(* P/M: Power Meter with power sensor)

Ch	Freq. [MHz]	P/M (Peak) Reading [dBm]	Cable Loss [dB]	Atten. Loss [dB]	Result		Limit		Margin [dB]
					[dBm]	[mW]	[dBm]	[mW]	
Low	2412.0	0.84	1.43	20.22	22.49	177.54	30.00	1000	7.51
Mid	2437.0	0.79	1.44	20.23	22.46	176.32	30.00	1000	7.54
High1	2462.0	0.76	1.44	20.23	22.43	175.11	30.00	1000	7.57
High2	2467.0	-5.83	1.44	20.23	15.84	38.40	30.00	1000	14.16
High3	2472.0	-10.01	1.44	20.23	11.66	14.67	30.00	1000	18.34

Antenna 1

(* P/M: Power Meter with power sensor)

Ch	Freq. [MHz]	P/M (Peak) Reading [dBm]	Cable Loss [dB]	Atten. Loss [dB]	Result		Limit		Margin [dB]
					[dBm]	[mW]	[dBm]	[mW]	
Low	2412.0	0.23	1.36	20.22	21.81	151.71	30.00	1000	8.19
Mid	2437.0	0.52	1.37	20.23	22.12	162.93	30.00	1000	7.88
High1	2462.0	0.50	1.37	20.23	22.10	162.18	30.00	1000	7.90
High2	2467.0	-6.14	1.37	20.23	15.46	35.16	30.00	1000	14.54
High3	2472.0	-10.15	1.37	20.23	11.45	13.96	30.00	1000	18.55

Sample Calculation:

Result = Reading + Cable Loss (including the cable(s) customer supplied) + Atten. Loss

[Pre check]

Mode (MCS)	Freq. [MHz]	Reading (Peak) Antenna 0		Reading (Peak) Antenna 1		Reading (Peak) Antenna 0 + 1	
		[dBm]	[mW]	[dBm]	[mW]	[dBm]	[mW]
0	2437.0	-1.29	0.74	-1.92	0.64	1.40	1.38
1	2437.0	-1.67	0.68	-1.95	0.64	1.21	1.32
2	2437.0	-1.42	0.72	-2.12	0.61	1.24	1.33
3	2437.0	0.79	1.20	0.52	1.13	3.67	2.33
4	2437.0	0.77	1.19	0.11	1.03	3.46	2.22
5	2437.0	0.73	1.18	-0.14	0.97	3.32	2.15
6	2437.0	0.77	1.19	-0.09	0.98	3.36	2.17
7	2437.0	0.66	1.16	-0.19	0.96	3.26	2.12
8	2437.0	0.01	1.00	-0.75	0.84	2.65	1.84

Worst

Sample Calculation:

Result = Reading + Cable Loss (including the cable(s) customer supplied) + Attenuator Loss

UL Japan, Inc.

Shonan EMC Lab.

1-22-3 Megumigaoka, Hiratsuka-shi, Kanagawa-ken, 259-1220 JAPAN

Telephone : +81 463 50 6400

Facsimile : +81 463 50 6401

Maximum Peak Output Power

Test place Shonan EMC Lab. No.1 Measurement Room
Report No. 11334871S-A-R1
Date October 31, 2016
Temperature / Humidity 24 deg. C / 44 % RH
Engineer Kenichi Adachi
Mode Tx 11n-40, MIMO

Antenna 0 + Antenna 1

Ch	Freq. [MHz]	Result Ant 0 [mW]	Result Ant 1 [mW]	-	Result		Limit		Margin [dB]
					Ant 0 + Ant 1 [dBm]	[mW]	[dBm]	[mW]	
Low	2422.0	82.85	63.24	-	21.65	146.09	30.00	1000	8.35
Mid	2437.0	79.12	71.12	-	21.77	150.24	30.00	1000	8.23
High1	2452.0	75.39	68.55	-	21.58	143.94	30.00	1000	8.42
High2	2457.0	74.70	61.24	-	21.33	135.94	30.00	1000	8.67
High3	2462.0	42.69	38.82	-	19.11	81.51	30.00	1000	10.89

Antenna 0

(* P/M: Power Meter with power sensor)

Ch	Freq. [MHz]	P/M (Peak) Reading [dBm]	Cable Loss [dB]	Atten. Loss [dB]	Result		Limit		Margin [dB]
					[dBm]	[mW]	[dBm]	[mW]	
Low	2422.0	-2.48	1.43	20.23	19.18	82.85	30.00	1000	10.82
Mid	2437.0	-2.69	1.44	20.23	18.98	79.12	30.00	1000	11.02
High1	2452.0	-2.90	1.44	20.23	18.77	75.39	30.00	1000	11.23
High2	2457.0	-2.94	1.44	20.23	18.73	74.70	30.00	1000	11.27
High3	2462.0	-5.37	1.44	20.23	16.30	42.69	30.00	1000	13.70

Antenna 1

(* P/M: Power Meter with power sensor)

Ch	Freq. [MHz]	P/M (Peak) Reading [dBm]	Cable Loss [dB]	Atten. Loss [dB]	Result		Limit		Margin [dB]
					[dBm]	[mW]	[dBm]	[mW]	
Low	2422.0	-3.58	1.36	20.23	18.01	63.24	30.00	1000	11.99
Mid	2437.0	-3.08	1.37	20.23	18.52	71.12	30.00	1000	11.48
High1	2452.0	-3.24	1.37	20.23	18.36	68.55	30.00	1000	11.64
High2	2457.0	-3.73	1.37	20.23	17.87	61.24	30.00	1000	12.13
High3	2462.0	-5.71	1.37	20.23	15.89	38.82	30.00	1000	14.11

Sample Calculation:

Result = Reading + Cable Loss (including the cable(s) customer supplied) + Atten. Loss

[Pre check]

Mode (MCS)	Freq. [MHz]	Reading Antenna 0		Reading Antenna 1		Reading Antenna 0 + 1	
		[dBm]	[mW]	[dBm]	[mW]	[dBm]	[mW]
8	2437.0	-4.59	0.35	-5.34	0.29	-1.94	0.64
9	2437.0	-4.51	0.35	-5.32	0.29	-1.94	0.64
10	2437.0	-4.72	0.34	-5.33	0.29	-2.01	0.63
11	2437.0	-2.69	0.54	-3.08	0.49	0.13	1.03
12	2437.0	-2.61	0.55	-3.51	0.45	0.00	1.00
13	2437.0	-2.56	0.55	-3.61	0.44	-0.04	0.99
14	2437.0	-2.77	0.53	-3.66	0.43	-0.18	0.96
15	2437.0	-2.45	0.57	-3.62	0.43	0.00	1.00

Worst

Sample Calculation:

Result = Reading + Cable Loss (including the cable(s) customer supplied) + Attenuator Loss

UL Japan, Inc.

Shonan EMC Lab.

1-22-3 Megumigaoka, Hiratsuka-shi, Kanagawa-ken, 259-1220 JAPAN

Telephone : +81 463 50 6400

Facsimile : +81 463 50 6401

Maximum Peak Output Power

Test place : Shonan EMC Lab. No.1 Measurement Room
Report No. : 11334871S-A-R1
Date : October 31, 2016
Temperature / Humidity : 24 deg. C / 44 % RH
Engineer : Kenichi Adachi
Mode : Tx OFDM, VHT40, MIMO

Antenna 0 + Antenna 1

Ch	Freq. [MHz]	Result Ant 0 [mW]	Result Ant 1 [mW]	-	Result Ant 0 + Ant 1		Limit		Margin [dB]
					[dBm]	[mW]	[dBm]	[mW]	
Low	2422.0	80.41	61.94	-	21.53	142.35	30.00	1000	8.47
Mid	2437.0	81.90	62.95	-	21.61	144.85	30.00	1000	8.39
High1	2452.0	82.85	63.68	-	21.66	146.53	30.00	1000	8.34
High2	2457.0	76.97	66.37	-	21.56	143.34	30.00	1000	8.44
High3	2462.0	42.30	36.48	-	18.96	78.78	30.00	1000	11.04

Antenna 0

(* P/M: Power Meter with power sensor)

Ch	Freq. [MHz]	P/M (Peak) Reading [dBm]	Cable Loss [dB]	Atten. Loss [dB]	Result		Limit		Margin [dB]
					[dBm]	[mW]	[dBm]	[mW]	
Low	2422.0	-2.61	1.43	20.23	19.05	80.41	30.00	1000	10.95
Mid	2437.0	-2.54	1.44	20.23	19.13	81.90	30.00	1000	10.87
High1	2452.0	-2.49	1.44	20.23	19.18	82.85	30.00	1000	10.82
High2	2457.0	-2.81	1.44	20.23	18.86	76.97	30.00	1000	11.14
High3	2462.0	-5.41	1.44	20.23	16.26	42.30	30.00	1000	13.74

Antenna 1

(* P/M: Power Meter with power sensor)

Ch	Freq. [MHz]	P/M (Peak) Reading [dBm]	Cable Loss [dB]	Atten. Loss [dB]	Result		Limit		Margin [dB]
					[dBm]	[mW]	[dBm]	[mW]	
Low	2422.0	-3.67	1.36	20.23	17.92	61.94	30.00	1000	12.08
Mid	2437.0	-3.61	1.37	20.23	17.99	62.95	30.00	1000	12.01
High1	2452.0	-3.56	1.37	20.23	18.04	63.68	30.00	1000	11.96
High2	2457.0	-3.38	1.37	20.23	18.22	66.37	30.00	1000	11.78
High3	2462.0	-5.98	1.37	20.23	15.62	36.48	30.00	1000	14.38

Sample Calculation:

Result = Reading + Cable Loss (including the cable(s) customer supplied) + Atten. Loss

[Pre check]

Mode (MCS)	Freq. [MHz]	Reading (Peak) Antenna 0		Reading (Peak) Antenna 1		Reading (Peak) Antenna 0 + 1	
		[dBm]	[mW]	[dBm]	[mW]	[dBm]	[mW]
0	2437.0	-4.55	0.35	-5.58	0.28	-2.01	0.63
1	2437.0	-4.58	0.35	-5.53	0.28	-2.01	0.63
2	2437.0	-4.51	0.35	-5.64	0.27	-2.08	0.62
3	2437.0	-2.54	0.56	-3.61	0.44	0.00	1.00
4	2437.0	-2.65	0.54	-3.87	0.41	-0.22	0.95
5	2437.0	-2.71	0.54	-4.01	0.40	-0.27	0.94
6	2437.0	-2.63	0.55	-4.05	0.39	-0.27	0.94
7	2437.0	-2.51	0.56	-4.06	0.39	-0.22	0.95
8	2437.0	-2.56	0.55	-4.17	0.38	-0.32	0.93
9	2437.0	-2.65	0.54	-4.13	0.39	-0.32	0.93

Worst

Sample Calculation:

Result = Reading + Cable Loss (including the cable(s) customer supplied) + Attenuator Loss

UL Japan, Inc.

Shonan EMC Lab.

1-22-3 Megumigaoka, Hiratsuka-shi, Kanagawa-ken, 259-1220 JAPAN

Telephone : +81 463 50 6400

Facsimile : +81 463 50 6401

Maximum Peak Output Power

Test place Shonan EMC Lab. No.1 Measurement Room
Report No. 11334871S-A-R1
Date November 11, 2016
Temperature / Humidity 25 deg. C / 33 % RH
Engineer Hikaru Shirasawa
Mode Tx BT LE

Freq. [MHz]	Reading [dBm]	Cable Loss [dB]	Atten. Loss [dB]	Result		Limit		Margin [dB]
				[dBm]	[mW]	[dBm]	[mW]	
2402	-9.41	1.43	10.01	2.03	1.60	30.00	1000	27.97
2440	-9.24	1.44	10.01	2.21	1.66	30.00	1000	27.79
2480	-9.03	1.45	10.01	2.43	1.75	30.00	1000	27.57

Sample Calculation:

Result = Reading + Cable Loss (including the cable(s) customer supplied) + Attenuator Loss

*The equipment and cables were not used for factor 0 dB of the data sheets.

Average Output Power
(Reference data for RF Exposure / SAR testing)

Test place Shonan EMC Lab. No.1 Measurement Room
Report No. 11334871S-A-R1
Date October 21, 2016
Temperature / Humidity 26 deg. C / 45 % RH
Engineer Kenichi Adachi
Mode Tx, SISO

11b **5.5 Mbps** worst antenna: 1

Freq. [MHz]	Reading [dBm]	Cable Loss [dB]	Atten. Loss [dB]	Result (Time average)		Duty factor [dB]	Result (Burst power average)	
				[dBm]	[mW]		[dBm]	[mW]
2412	-4.90	2.04	20.22	17.36	54.45	0.23	17.59	57.41
2437	-4.78	2.04	20.23	17.49	56.10	0.23	17.72	59.16
2462	-4.82	2.05	20.23	17.46	55.72	0.23	17.69	58.75
2467	-14.08	2.05	20.23	8.20	6.61	0.23	8.43	6.97
2472	-19.16	2.05	20.23	3.12	2.05	0.23	3.35	2.16

11g **12 Mbps** worst antenna: 1 (for 2412-2462 MHz)
6 Mbps worst antenna: 1 (for 2467-2472 MHz)

Freq. [MHz]	Reading [dBm]	Cable Loss [dB]	Atten. Loss [dB]	Result (Time average)		Duty factor [dB]	Result (Burst power average)	
				[dBm]	[mW]		[dBm]	[mW]
2412	-6.64	2.04	20.22	15.62	36.48	0.55	16.17	41.40
2437	-6.42	2.04	20.23	15.85	38.46	0.55	16.40	43.65
2462	-6.56	2.05	20.23	15.72	37.33	0.55	16.27	42.36
2467	-13.02	2.05	20.23	9.26	8.43	0.28	9.54	8.99
2472	-19.17	2.05	20.23	3.11	2.05	0.28	3.39	2.18

11n-20 **MCS 3** worst antenna: 1 (for 2412-2462 MHz), 1 (for 2467-2472 MHz)

Freq. [MHz]	Reading [dBm]	Cable Loss [dB]	Atten. Loss [dB]	Result (Time average)		Duty factor [dB]	Result (Burst power average)	
				[dBm]	[mW]		[dBm]	[mW]
2412	-6.88	2.04	20.22	15.38	34.51	1.03	16.41	43.75
2437	-6.90	2.04	20.23	15.37	34.43	1.03	16.40	43.65
2462	-6.75	2.05	20.23	15.53	35.73	1.03	16.56	45.29
2467	-14.78	2.05	20.23	7.50	5.62	1.03	8.53	7.13
2472	-19.76	2.05	20.23	2.52	1.79	1.03	3.55	2.26

OFDM, VHT20 **MCS 3** worst antenna: 1 (for 2412-2462 MHz), 1 (for 2467-2472 MHz)

Freq. [MHz]	Reading [dBm]	Cable Loss [dB]	Atten. Loss [dB]	Result (Time average)		Duty factor [dB]	Result (Burst power average)	
				[dBm]	[mW]		[dBm]	[mW]
2412	-6.77	2.04	20.22	15.49	35.40	1.02	16.51	44.77
2437	-6.75	2.04	20.23	15.52	35.65	1.02	16.54	45.08
2462	-6.87	2.05	20.23	15.41	34.75	1.02	16.43	43.95
2467	-14.89	2.05	20.23	7.39	5.48	1.02	8.41	6.93
2472	-19.81	2.05	20.23	2.47	1.77	1.02	3.49	2.23

Sample Calculation:
Result (Time average) = Reading + Cable Loss (including the cable(s) customer supplied) + Attenuator
Result (Burst power average) = Time average power + Duty factor

*The test was performed with condition that obtained the maximum Burst power average in pre-check.

Average Output Power
(Reference data for RF Exposure / SAR testing)

Test place : Shonan EMC Lab. No.1 Measurement Room
Report No. : 11334871S-A-R1
Date : October 21, 2016
Temperature / Humidity : 26 deg. C / 45 % RH
Engineer : Kenichi Adachi
Mode : Tx, SISO

11n-40 **MCS 3** worst antenna: 0

Freq. [MHz]	Reading [dBm]	Cable Loss [dB]	Atten. Loss [dB]	Result (Time average)		Duty factor [dB]	Result (Burst power average)	
				[dBm]	[mW]		[dBm]	[mW]
2422	-14.72	2.11	20.23	7.62	5.78	1.74	9.36	8.63
2437	-14.73	2.11	20.23	7.61	5.77	1.74	9.35	8.61
2452	-14.68	2.11	20.23	7.66	5.83	1.74	9.40	8.71
2457	-14.74	2.11	20.23	7.60	5.75	1.74	9.34	8.59
2462	-14.64	2.12	20.23	7.71	5.90	1.74	9.45	8.81

OFDM, VHT40 **MCS 3** worst antenna: 0

Freq. [MHz]	Reading [dBm]	Cable Loss [dB]	Atten. Loss [dB]	Result (Time average)		Duty factor [dB]	Result (Burst power average)	
				[dBm]	[mW]		[dBm]	[mW]
2422	-14.69	2.11	20.23	7.65	5.82	1.69	9.34	8.59
2437	-14.67	2.11	20.23	7.67	5.85	1.69	9.36	8.63
2452	-14.66	2.11	20.23	7.68	5.86	1.69	9.37	8.65
2457	-14.68	2.11	20.23	7.66	5.83	1.69	9.35	8.61
2462	-14.61	2.12	20.23	7.74	5.94	1.69	9.43	8.77

Sample Calculation:

Result (Time average) = Reading + Cable Loss (including the cable(s) customer supplied) + Attenuator

Result (Burst power average) = Time average power + Duty factor

*The test was performed with condition that obtained the maximum Burst power average in pre-check

Average Output Power
(Reference data for RF Exposure / SAR testing)

Test place Shonan EMC Lab. No.1 Measurement Room
Report No. 11334871S-A-R1
Date October 21, 2016
Temperature / Humidity 26 deg. C / 45 % RH
Engineer Kenichi Adachi
Mode Tx, SISO

11b

[Pre check]
Antenna: 0

	Data rate	Freq.	P/M (AV)	Cable	Atten.	Duty	Result	
	[Mbps]	[MHz]	Reading [dBm]	Loss [dB]	Loss [dB]	Factor [dB]	[dBm]	[mW]
0	1	2437.0	-5.56	2.11	20.23	0.04	16.82	48.08
0	2	2437.0	-5.46	2.11	20.23	0.09	16.97	49.77
0	5.5	2437.0	-5.59	2.11	20.23	0.23	16.98	49.89
0	11	2437.0	-5.82	2.11	20.23	0.43	16.95	49.55

Antenna: 1

	Data rate	Freq.	P/M (AV)	Cable	Atten.	Duty	Result	
	[Mbps]	[MHz]	Reading [dBm]	Loss [dB]	Loss [dB]	Factor [dB]	[dBm]	[mW]
1	1	2437.0	-4.92	2.04	20.23	0.04	17.39	54.83
1	2	2437.0	-4.69	2.04	20.23	0.09	17.67	58.48
1	5.5	2437.0	-4.78	2.04	20.23	0.23	17.72	59.16
1	11	2437.0	-4.99	2.04	20.23	0.43	17.71	59.02

Sample Calculation:

Result = Reading + Cable Loss (including the cable(s) customer supplied) + Atten. Loss + Duty Factor

11g

[Pre check]
Antenna: 0

	Data rate	Freq.	P/M (AV)	Cable	Atten.	Duty	Result	
	[Mbps]	[MHz]	Reading [dBm]	Loss [dB]	Loss [dB]	Factor [dB]	[dBm]	[mW]
0	6	2437.0	-6.40	2.11	20.23	0.28	16.22	41.88
0	9	2437.0	-6.54	2.11	20.23	0.42	16.22	41.88
0	12	2437.0	-6.61	2.11	20.23	0.55	16.28	42.46
0	18	2437.0	-6.86	2.11	20.23	0.79	16.27	42.36
0	24	2437.0	-8.69	2.11	20.23	1.01	14.66	29.24
0	36	2437.0	-9.10	2.11	20.23	1.41	14.65	29.17
0	48	2437.0	-9.42	2.11	20.23	1.76	14.68	29.38
0	54	2437.0	-9.63	2.11	20.23	1.87	14.58	28.71

Antenna: 1

	Data rate	Freq.	P/M (AV)	Cable	Atten.	Duty	Result	
	[Mbps]	[MHz]	Reading [dBm]	Loss [dB]	Loss [dB]	Factor [dB]	[dBm]	[mW]
1	6	2437.0	-6.17	2.04	20.23	0.28	16.38	43.45
1	9	2437.0	-6.35	2.04	20.23	0.42	16.34	43.05
1	12	2437.0	-6.42	2.04	20.23	0.55	16.40	43.65
1	18	2437.0	-6.69	2.04	20.23	0.79	16.37	43.35
1	24	2437.0	-8.53	2.04	20.23	1.01	14.75	29.85
1	36	2437.0	-9.03	2.04	20.23	1.41	14.65	29.17
1	48	2437.0	-9.24	2.04	20.23	1.76	14.79	30.13
1	54	2437.0	-9.43	2.04	20.23	1.87	14.71	29.58

Antenna: 0

	Data rate	Freq.	P/M (AV)	Cable	Atten.	Duty	Result	
	[Mbps]	[MHz]	Reading [dBm]	Loss [dB]	Loss [dB]	Factor [dB]	[dBm]	[mW]
0	6	2467.0	-14.09	2.12	20.23	0.28	8.54	7.14
0	9	2467.0	-14.29	2.12	20.23	0.42	8.48	7.05
0	12	2467.0	-14.41	2.12	20.23	0.55	8.49	7.06
0	18	2467.0	-14.71	2.12	20.23	0.79	8.43	6.97
0	24	2467.0	-14.79	2.12	20.23	1.01	8.57	7.19
0	36	2467.0	-15.16	2.12	20.23	1.41	8.60	7.24
0	48	2467.0	-15.41	2.12	20.23	1.76	8.70	7.41
0	54	2467.0	-15.60	2.12	20.23	1.87	8.62	7.28

Antenna: 1

	Data rate	Freq.	P/M (AV)	Cable	Atten.	Duty	Result	
	[Mbps]	[MHz]	Reading [dBm]	Loss [dB]	Loss [dB]	Factor [dB]	[dBm]	[mW]
1	6	2467.0	-13.02	2.05	20.23	0.28	9.54	8.99
1	9	2467.0	-13.29	2.05	20.23	0.42	9.41	8.73
1	12	2467.0	-13.57	2.05	20.23	0.55	9.26	8.43
1	18	2467.0	-13.93	2.05	20.23	0.79	9.14	8.20
1	24	2467.0	-14.09	2.05	20.23	1.01	9.20	8.32
1	36	2467.0	-14.44	2.05	20.23	1.41	9.25	8.41
1	48	2467.0	-14.67	2.05	20.23	1.76	9.37	8.65
1	54	2467.0	-14.82	2.05	20.23	1.87	9.33	8.57

Sample Calculation:

Result = Reading + Cable Loss (including the cable(s) customer supplied) + Atten. Loss + Duty Factor

Average Output Power
(Reference data for RF Exposure / SAR testing)

Test place Shonan EMC Lab. No.1 Measurement Room
Report No. 11334871S-A-R1
Date October 21, 2016
Temperature / Humidity 26 deg. C / 45 % RH
Engineer Kenichi Adachi
Mode Tx 11n-20, SISO

11n-20

[Pre check]

Antenna: 0

	MCS	Freq. [MHz]	P/M (AV) Reading [dBm]	Cable Loss [dB]	Atten. Loss [dB]	Duty Factor [dB]	Result	
							[dBm]	[mW]
0	0	2437.0	-6.47	2.11	20.23	0.31	16.18	41.50
0	1	2437.0	-6.76	2.11	20.23	0.58	16.16	41.30
0	2	2437.0	-7.01	2.11	20.23	0.81	16.14	41.11
0	3	2437.0	-6.98	2.11	20.23	1.03	16.39	43.55
0	4	2437.0	-8.32	2.11	20.23	1.40	15.42	34.83
0	5	2437.0	-8.87	2.11	20.23	1.73	15.20	33.11
0	6	2437.0	-8.69	2.11	20.23	1.85	15.50	35.48
0	7	2437.0	-9.95	2.11	20.23	2.00	14.39	27.48

Antenna: 1

	MCS	Freq. [MHz]	P/M (AV) Reading [dBm]	Cable Loss [dB]	Atten. Loss [dB]	Duty Factor [dB]	Result	
							[dBm]	[mW]
1	0	2437.0	-6.49	2.04	20.23	0.31	16.09	40.64
1	1	2437.0	-6.78	2.04	20.23	0.58	16.07	40.46
1	2	2437.0	-7.06	2.04	20.23	0.81	16.02	39.99
1	3	2437.0	-6.90	2.04	20.23	1.03	16.40	43.65
1	4	2437.0	-8.18	2.04	20.23	1.40	15.49	35.40
1	5	2437.0	-8.53	2.04	20.23	1.73	15.47	35.24
1	6	2437.0	-8.68	2.04	20.23	1.85	15.44	34.99
1	7	2437.0	-9.75	2.04	20.23	2.00	14.52	28.31

worst

Antenna: 0

	MCS	Freq. [MHz]	P/M (AV) Reading [dBm]	Cable Loss [dB]	Atten. Loss [dB]	Duty Factor [dB]	Result	
							[dBm]	[mW]
0	0	2467.0	-15.21	2.12	20.23	0.31	7.45	5.56
0	1	2467.0	-15.49	2.12	20.23	0.58	7.44	5.55
0	2	2467.0	-15.86	2.12	20.23	0.81	7.30	5.37
0	3	2467.0	-15.72	2.12	20.23	1.03	7.66	5.83
0	4	2467.0	-16.13	2.12	20.23	1.40	7.62	5.78
0	5	2467.0	-16.42	2.12	20.23	1.73	7.66	5.83
0	6	2467.0	-16.63	2.12	20.23	1.85	7.57	5.71
0	7	2467.0	-16.78	2.12	20.23	2.00	7.57	5.71

Antenna: 1

	MCS	Freq. [MHz]	P/M (AV) Reading [dBm]	Cable Loss [dB]	Atten. Loss [dB]	Duty Factor [dB]	Result	
							[dBm]	[mW]
1	0	2467.0	-14.35	2.05	20.23	0.31	8.24	6.67
1	1	2467.0	-14.73	2.05	20.23	0.58	8.13	6.50
1	2	2467.0	-15.10	2.05	20.23	0.81	7.99	6.30
1	3	2467.0	-14.78	2.05	20.23	1.03	8.53	7.13
1	4	2467.0	-15.55	2.05	20.23	1.40	8.13	6.50
1	5	2467.0	-15.75	2.05	20.23	1.73	8.26	6.70
1	6	2467.0	-15.84	2.05	20.23	1.85	8.29	6.75
1	7	2467.0	-15.96	2.05	20.23	2.00	8.32	6.79

worst

Sample Calculation:

Result = Reading + Cable Loss (including the cable(s) customer supplied) + Atten. Loss + Duty Factor

Average Output Power
(Reference data for RF Exposure / SAR testing)

Test place : Shonan EMC Lab. No.1 Measurement Room
Report No. : 11334871S-A-R1
Date : October 21, 2016
Temperature / Humidity : 26 deg. C / 45 % RH
Engineer : Kenichi Adachi
Mode : Tx OFDM, VHT20, SISO

OFDM VHT20

[Pre check]

Antenna: 0

	MCS	Freq. [MHz]	P/M (AV) Reading [dBm]	Cable Loss [dB]	Atten. Loss [dB]	Duty Factor [dB]	Result	
							[dBm]	[mW]
0	0	2437.0	-6.43	2.11	20.23	0.30	16.21	41.78
0	1	2437.0	-6.66	2.11	20.23	0.57	16.25	42.17
0	2	2437.0	-6.90	2.11	20.23	0.81	16.25	42.17
0	3	2437.0	-6.84	2.11	20.23	1.02	16.52	44.87
0	4	2437.0	-8.20	2.11	20.23	1.39	15.53	35.73
0	5	2437.0	-8.49	2.11	20.23	1.70	15.55	35.89
0	6	2437.0	-8.62	2.11	20.23	1.81	15.53	35.73
0	7	2437.0	-9.64	2.11	20.23	1.95	14.65	29.17
0	8	2437.0	-11.20	2.11	20.23	2.15	13.29	21.33

Antenna: 1

	MCS	Freq. [MHz]	P/M (AV) Reading [dBm]	Cable Loss [dB]	Atten. Loss [dB]	Duty Factor [dB]	Result	
							[dBm]	[mW]
1	0	2437.0	-6.33	2.04	20.23	0.30	16.24	42.07
1	1	2437.0	-6.57	2.04	20.23	0.57	16.27	42.36
1	2	2437.0	-6.84	2.04	20.23	0.81	16.24	42.07
1	3	2437.0	-6.75	2.04	20.23	1.02	16.54	45.08
1	4	2437.0	-8.07	2.04	20.23	1.39	15.59	36.22
1	5	2437.0	-8.39	2.04	20.23	1.70	15.58	36.14
1	6	2437.0	-8.45	2.04	20.23	1.81	15.63	36.56
1	7	2437.0	-9.58	2.04	20.23	1.95	14.64	29.11
1	8	2437.0	-11.15	2.04	20.23	2.15	13.27	21.23

Antenna: 0

	MCS	Freq. [MHz]	P/M (AV) Reading [dBm]	Cable Loss [dB]	Atten. Loss [dB]	Duty Factor [dB]	Result	
							[dBm]	[mW]
0	0	2467.0	-15.36	2.12	20.23	0.30	7.29	5.36
0	1	2467.0	-15.61	2.12	20.23	0.57	7.31	5.38
0	2	2467.0	-15.82	2.12	20.23	0.81	7.34	5.42
0	3	2467.0	-15.85	2.12	20.23	1.02	7.52	5.65
0	4	2467.0	-16.09	2.12	20.23	1.39	7.65	5.82
0	5	2467.0	-16.56	2.12	20.23	1.70	7.49	5.61
0	6	2467.0	-16.73	2.12	20.23	1.81	7.43	5.53
0	7	2467.0	-16.81	2.12	20.23	1.95	7.49	5.61
0	8	2467.0	-17.03	2.12	20.23	2.15	7.47	5.58

Antenna: 1

	MCS	Freq. [MHz]	P/M (AV) Reading [dBm]	Cable Loss [dB]	Atten. Loss [dB]	Duty Factor [dB]	Result	
							[dBm]	[mW]
1	0	2467.0	-14.53	2.05	20.23	0.30	8.05	6.38
1	1	2467.0	-14.83	2.05	20.23	0.57	8.02	6.34
1	2	2467.0	-15.16	2.05	20.23	0.81	7.93	6.21
1	3	2467.0	-14.89	2.05	20.23	1.02	8.41	6.93
1	4	2467.0	-15.31	2.05	20.23	1.39	8.36	6.85
1	5	2467.0	-15.63	2.05	20.23	1.70	8.35	6.84
1	6	2467.0	-15.96	2.05	20.23	1.81	8.13	6.50
1	7	2467.0	-16.01	2.05	20.23	1.95	8.22	6.64
1	8	2467.0	-16.26	2.05	20.23	2.15	8.17	6.56

Sample Calculation:

Result = Reading + Cable Loss (including the cable(s) customer supplied) + Atten. Loss + Duty Factor

Average Output Power
(Reference data for RF Exposure / SAR testing)

Test place Shonan EMC Lab. No.1 Measurement Room
Report No. 11334871S-A-R1
Date October 21, 2016
Temperature / Humidity 26 deg. C / 45 % RH
Engineer Kenichi Adachi
Mode Tx 11n-40, SISO

11n-40

[Pre check]

Antenna: 0

	MCS	Freq. [MHz]	P/M (AV) Reading [dBm]	Cable Loss [dB]	Atten. Loss [dB]	Duty Factor [dB]	Result	
							[dBm]	[mW]
0	0	2437.0	-13.65	2.11	20.23	0.59	9.28	8.47
0	1	2437.0	-14.19	2.11	20.23	1.05	9.20	8.32
0	2	2437.0	-14.78	2.11	20.23	1.43	8.99	7.93
0	3	2437.0	-14.73	2.11	20.23	1.74	9.35	8.61
0	4	2437.0	-16.22	2.11	20.23	2.23	8.35	6.84
0	5	2437.0	-16.67	2.11	20.23	2.62	8.29	6.75
0	6	2437.0	-16.79	2.11	20.23	2.76	8.31	6.78
0	7	2437.0	-17.99	2.11	20.23	2.93	7.28	5.35

worst

Antenna: 1

	MCS	Freq. [MHz]	P/M (AV) Reading [dBm]	Cable Loss [dB]	Atten. Loss [dB]	Duty Factor [dB]	Result	
							[dBm]	[mW]
1	0	2437.0	-13.68	2.04	20.23	0.59	9.18	8.28
1	1	2437.0	-14.11	2.04	20.23	1.05	9.21	8.34
1	2	2437.0	-14.46	2.04	20.23	1.43	9.24	8.39
1	3	2437.0	-14.76	2.04	20.23	1.74	9.25	8.41
1	4	2437.0	-16.23	2.04	20.23	2.23	8.27	6.71
1	5	2437.0	-16.70	2.04	20.23	2.62	8.19	6.59
1	6	2437.0	-16.80	2.04	20.23	2.76	8.23	6.65
1	7	2437.0	-18.02	2.04	20.23	2.93	7.18	5.22

Sample Calculation:

Result = Reading + Cable Loss (including the cable(s) customer supplied) + Atten. Loss + Duty Factor

Average Output Power
(Reference data for RF Exposure / SAR testing)

Test place Shonan EMC Lab. No.1 Measurement Room
Report No. 11334871S-A-R1
Date October 21, 2016
Temperature / Humidity 26 deg. C / 45 % RH
Engineer Kenichi Adachi
Mode Tx OFDM, VHT40, SISO

OFDM VHT40

[Pre check]

Antenna: 0

	MCS	Freq. [MHz]	P/M (A/V) Reading [dBm]	Cable Loss [dB]	Atten. Loss [dB]	Duty Factor [dB]	Result	
							[dBm]	[mW]
0	0	2437.0	-13.73	2.11	20.23	0.59	9.20	8.32
0	1	2437.0	-14.16	2.11	20.23	1.03	9.21	8.34
0	2	2437.0	-14.63	2.11	20.23	1.39	9.10	8.13
0	3	2437.0	-14.67	2.11	20.23	1.69	9.36	8.63
0	4	2437.0	-15.71	2.11	20.23	2.14	8.77	7.53
0	5	2437.0	-16.19	2.11	20.23	2.51	8.66	7.35
0	6	2437.0	-16.29	2.11	20.23	2.63	8.68	7.38
0	7	2437.0	-17.44	2.11	20.23	2.79	7.69	5.87
0	8	2437.0	-19.01	2.11	20.23	2.95	6.28	4.25
0	9	2437.0	-19.35	2.11	20.23	3.14	6.13	4.10

worst

Antenna: 1

	MCS	Freq. [MHz]	P/M (A/V) Reading [dBm]	Cable Loss [dB]	Atten. Loss [dB]	Duty Factor [dB]	Result	
							[dBm]	[mW]
1	0	2437.0	-13.75	2.04	20.23	0.59	9.11	8.15
1	1	2437.0	-14.11	2.04	20.23	1.03	9.19	8.30
1	2	2437.0	-14.45	2.04	20.23	1.39	9.21	8.34
1	3	2437.0	-14.75	2.04	20.23	1.69	9.21	8.34
1	4	2437.0	-15.69	2.04	20.23	2.14	8.72	7.45
1	5	2437.0	-16.10	2.04	20.23	2.51	8.68	7.38
1	6	2437.0	-16.30	2.04	20.23	2.63	8.60	7.24
1	7	2437.0	-17.34	2.04	20.23	2.79	7.72	5.92
1	8	2437.0	-19.04	2.04	20.23	2.95	6.18	4.15
1	9	2437.0	-19.26	2.04	20.23	3.14	6.15	4.12

Sample Calculation:

Result = Reading + Cable Loss (including the cable(s) customer supplied) + Atten. Loss + Duty Factor

Average Output Power
(Reference data for RF Exposure / SAR testing)

Test place : Shonan EMC Lab. No.1 Measurement Room
Report No. : 11334871S-A-R1
Date : October 31, 2016
Temperature / Humidity : 24 deg. C / 44 % RH
Engineer : Kenichi Adachi
Mode : Tx 11n-20, MIMO

Antenna: 0 + Antenna: 1 (Burst power average) (Time average)

Ch	Freq. [MHz]	Ant: 0		Ant: 1		Result (Burst power average)		Result (Time average)	
		Result [mW]	Result [mW]	Result [mW]	Result [mW]	[dBm]	[mW]	[dBm]	[mW]
Low	2412.0	17.11	14.59	11.57	9.86	15.01	31.70	13.31	21.43
Mid	2437.0	16.49	14.22	11.15	9.62	14.87	30.71	13.17	20.77
High1	2462.0	16.27	14.49	11.00	9.79	14.88	30.76	13.18	20.79
High2	2467.0	3.66	3.03	2.47	2.05	8.25	6.69	6.55	4.52
High3	2472.0	1.20	1.05	0.81	0.71	3.52	2.25	1.82	1.52

Sample Calculation: Result [mW] = Antenna: 0 Result [mW] + Antenna: 1 Result [mW]

Antenna: 0 (* P/M: Power Meter with power sensor, AV: Average with gate trigger mode)

Ch	Freq. [MHz]	P/M (AV) Reading [dBm]	Cable Loss [dB]	Atten. Loss [dB]	Duty Factor [dB]	Result (Burst power average)		Result (Time average)	
						[dBm]	[mW]	[dBm]	[mW]
Low	2412.0	-11.02	1.43	20.22	1.70	12.33	17.11	10.63	11.57
Mid	2437.0	-11.20	1.44	20.23	1.70	12.17	16.49	10.47	11.15
High1	2462.0	-11.26	1.44	20.23	1.70	12.11	16.27	10.41	11.00
High2	2467.0	-17.74	1.44	20.23	1.70	5.63	3.66	3.93	2.47
High3	2472.0	-22.59	1.44	20.23	1.70	0.78	1.20	-0.92	0.81

Antenna: 1 (* P/M: Power Meter with power sensor, AV: Average with gate trigger mode)

Ch	Freq. [MHz]	P/M (AV) Reading [dBm]	Cable Loss [dB]	Atten. Loss [dB]	Duty Factor [dB]	Result (Burst power average)		Result (Time average)	
						[dBm]	[mW]	[dBm]	[mW]
Low	2412.0	-11.64	1.36	20.22	1.70	11.64	14.59	9.94	9.86
Mid	2437.0	-11.77	1.37	20.23	1.70	11.53	14.22	9.83	9.62
High1	2462.0	-11.69	1.37	20.23	1.70	11.61	14.49	9.91	9.79
High2	2467.0	-18.48	1.37	20.23	1.70	4.82	3.03	3.12	2.05
High3	2472.0	-23.07	1.37	20.23	1.70	0.23	1.05	-1.47	0.71

Sample Calculation:

Result = Reading + Cable Loss (including the cable(s) customer supplied) + Atten. Loss

[Pre check]

Mode (MCS)	Freq. [MHz]	Duty factor [dB]	Antenna: 0			Antenna: 1			Antenna- 0 + 1	
			Reading [dBm]	Result [dBm]	[mW]	Reading [dBm]	Result [dBm]	[mW]	[dBm]	[mW]
8	2437.0	0.56	-10.41	-9.85	0.104	-10.98	-10.42	0.091	-7.12	0.194
9	2437.0	1.02	-10.84	-9.82	0.104	-11.41	-10.39	0.091	-7.09	0.196
10	2437.0	1.38	-11.27	-9.89	0.103	-11.78	-10.40	0.091	-7.13	0.194
11	2437.0	1.70	-11.20	-9.50	0.112	-11.77	-10.07	0.098	-6.77	0.211
12	2437.0	2.15	-11.64	-9.49	0.112	-12.30	-10.15	0.097	-6.80	0.209
13	2437.0	2.51	-12.01	-9.50	0.112	-12.67	-10.16	0.096	-6.81	0.209
14	2437.0	2.64	-12.12	-9.48	0.113	-12.89	-10.25	0.094	-6.84	0.207
15	2437.0	2.77	-12.22	-9.45	0.114	-12.96	-10.19	0.096	-6.79	0.209

Worst

Sample Calculation: Result = Duty factor + Reading

* The test was performed with condition that obtained the maximum Result(Antenna 0+1) power in pre-check.

Average Output Power
(Reference data for RF Exposure / SAR testing)

Test place : Shonan EMC Lab. No.1 Measurement Room
Report No. : 11334871S-A-R1
Date : October 31, 2016
Temperature / Humidity : 24 deg. C / 44 % RH
Engineer : Kenichi Adachi
Mode : Tx OFDM, VHT20, MIMO

Antenna: 0 + Antenna: 1 (Burst power average) (Time average)

Ch	Freq. [MHz]	Ant: 0		Ant: 1		Result (Burst power average)		Result (Time average)	
		Result [mW]	Result [mW]	Result [mW]	Result [mW]	[dBm]	[mW]	[dBm]	[mW]
Low	2412.0	16.99	14.16	11.57	9.64	14.93	31.15	13.27	21.21
Mid	2437.0	16.23	15.00	11.05	10.21	14.95	31.23	13.28	21.26
High1	2462.0	15.97	14.89	10.87	10.14	14.89	30.86	13.22	21.01
High2	2467.0	3.66	3.02	2.49	2.06	8.25	6.68	6.58	4.55
High3	2472.0	1.21	1.05	0.82	0.72	3.54	2.26	1.88	1.54

Sample Calculation: Result [mW] = Antenna: 0 Result [mW] + Antenna: 1 Result [mW]

Antenna: 0 (* P/M: Power Meter with power sensor, AV: Average with gate trigger mode)

Ch	Freq. [MHz]	P/M (AV) Reading [dBm]	Cable Loss [dB]	Atten. Loss [dB]	Duty Factor [dB]	Result (Burst power average)		Result (Time average)	
						[dBm]	[mW]	[dBm]	[mW]
Low	2412.0	-11.02	1.43	20.22	1.67	12.30	16.99	10.63	11.57
Mid	2437.0	-11.24	1.44	20.23	1.67	12.10	16.23	10.43	11.05
High1	2462.0	-11.31	1.44	20.23	1.67	12.03	15.97	10.36	10.87
High2	2467.0	-17.71	1.44	20.23	1.67	5.63	3.66	3.96	2.49
High3	2472.0	-22.52	1.44	20.23	1.67	0.82	1.21	-0.85	0.82

Antenna: 1 (* P/M: Power Meter with power sensor, AV: Average with gate trigger mode)

Ch	Freq. [MHz]	P/M (AV) Reading [dBm]	Cable Loss [dB]	Atten. Loss [dB]	Duty Factor [dB]	Result (Burst power average)		Result (Time average)	
						[dBm]	[mW]	[dBm]	[mW]
Low	2412.0	-11.74	1.36	20.22	1.67	11.51	14.16	9.84	9.64
Mid	2437.0	-11.51	1.37	20.23	1.67	11.76	15.00	10.09	10.21
High1	2462.0	-11.54	1.37	20.23	1.67	11.73	14.89	10.06	10.14
High2	2467.0	-18.47	1.37	20.23	1.67	4.80	3.02	3.13	2.06
High3	2472.0	-23.05	1.37	20.23	1.67	0.22	1.05	-1.45	0.72

Sample Calculation:

Result = Reading + Cable Loss (including the cable(s) customer supplied) + Atten. Loss

[Pre check]

Mode (MCS)	Freq. [MHz]	Duty factor [dB]	Antenna: 0			Antenna: 1			Antenna- 0 + 1	
			Reading [dBm]	Result [dBm]	[mW]	Reading [dBm]	Result [dBm]	[mW]	Result [dBm]	[mW]
0	2437.0	0.57	-10.41	-9.84	0.104	-10.70	-10.13	0.097	-6.97	0.201
1	2437.0	1.01	-11.04	-10.03	0.099	-11.14	-10.13	0.097	-7.07	0.196
2	2437.0	1.37	-11.36	-9.99	0.100	-11.52	-10.15	0.097	-7.06	0.197
3	2437.0	1.67	-11.24	-9.57	0.110	-11.51	-9.84	0.104	-6.69	0.214
4	2437.0	2.11	-11.70	-9.59	0.110	-11.96	-9.85	0.104	-6.71	0.213
5	2437.0	2.46	-12.14	-9.68	0.108	-12.34	-9.88	0.103	-6.77	0.210
6	2437.0	2.57	-12.25	-9.68	0.108	-12.49	-9.92	0.102	-6.79	0.210
7	2437.0	2.70	-12.39	-9.69	0.107	-12.62	-9.92	0.102	-6.79	0.209
8	2437.0	2.96	-14.05	-11.09	0.078	-14.27	-11.31	0.074	-8.19	0.152

Sample Calculation: Result = Duty factor + Reading

* The test was performed with condition that obtained the maximum Result(Antenna 0+1) power in pre-check.

Worst

Average Output Power
(Reference data for RF Exposure / SAR testing)

Test place : Shonan EMC Lab. No.1 Measurement Room
Report No. : 11334871S-A-R1
Date : October 31, 2016 August 26, 2016
Temperature / Humidity : 24 deg. C / 44 % RH 26 deg. C / 42 % RH
Engineer : Kenichi Adachi Shinichi Takano
Mode : Tx 11n-40, MIMO

Antenna: 0 + Antenna: 1 (Burst power average) (Time average)

Ch	Freq. [MHz]	Ant: 0		Ant: 1		Result (Burst power average)		Result (Time average)	
		Result [mW]	Result [mW]	Result [mW]	Result [mW]	[dBm]	[mW]	[dBm]	[mW]
Low	2422.0	7.32	5.46	4.06	3.03	11.07	12.78	8.51	7.09
Mid	2437.0	7.27	5.69	4.03	3.16	11.13	12.96	8.57	7.19
High1	2452.0	7.18	5.73	3.98	3.18	11.11	12.91	8.55	7.16
High2	2457.0	7.27	5.58	4.03	3.10	11.09	12.85	8.53	7.13
High3	2462.0	3.92	3.18	2.17	1.76	8.51	7.10	5.94	3.93

Sample Calculation: Result [mW] = Antenna: 0 Result [mW] + Antenna: 1 Result [mW]

Antenna: 0 (* P/M: Power Meter with power sensor, AV: Average with gate trigger mode)

Ch	Freq. [MHz]	P/M (AV) Reading [dBm]	Cable Loss [dB]	Atten. Loss [dB]	Duty Factor [dB]	Result (Burst power average)		Result (Time average)	
						[dBm]	[mW]	[dBm]	[mW]
Low	2422.0	-15.58	1.43	20.23	2.56	8.64	7.32	6.08	4.06
Mid	2437.0	-15.62	1.44	20.23	2.56	8.61	7.27	6.05	4.03
High1	2452.0	-15.67	1.44	20.23	2.56	8.56	7.18	6.00	3.98
High2	2457.0	-15.62	1.44	20.23	2.56	8.61	7.27	6.05	4.03
High3	2462.0	-18.30	1.44	20.23	2.56	5.93	3.92	3.37	2.17

Antenna: 1 (* P/M: Power Meter with power sensor, AV: Average with gate trigger mode)

Ch	Freq. [MHz]	P/M (AV) Reading [dBm]	Cable Loss [dB]	Atten. Loss [dB]	Duty Factor [dB]	Result (Burst power average)		Result (Time average)	
						[dBm]	[mW]	[dBm]	[mW]
Low	2422.0	-16.78	1.36	20.23	2.56	7.37	5.46	4.81	3.03
Mid	2437.0	-16.61	1.37	20.23	2.56	7.55	5.69	4.99	3.16
High1	2452.0	-16.58	1.37	20.23	2.56	7.58	5.73	5.02	3.18
High2	2457.0	-16.69	1.37	20.23	2.56	7.47	5.58	4.91	3.10
High3	2462.0	-19.14	1.37	20.23	2.56	5.02	3.18	2.46	1.76

Sample Calculation:

Result = Reading + Cable Loss (including the cable(s) customer supplied) + Atten. Loss

[Pre check]

Mode (MCS)	Freq. [MHz]	Duty factor [dB]	Antenna: 0			Antenna: 1			Antenna- 0 + 1	
			Reading [dBm]	Result [dBm]	[mW]	Reading [dBm]	Result [dBm]	[mW]	[dBm]	[mW]
8	2437.0	1.05	-14.27	-13.22	0.048	-15.13	-14.08	0.039	-10.62	0.087
9	2437.0	1.72	-15.00	-13.28	0.047	-15.81	-14.09	0.039	-10.66	0.086
10	2437.0	2.18	-15.40	-13.22	0.048	-16.38	-14.20	0.038	-10.67	0.086
11	2437.0	2.56	-15.62	-13.06	0.049	-16.61	-14.05	0.039	-10.52	0.089
12	2437.0	3.01	-16.26	-13.25	0.047	-17.20	-14.19	0.038	-10.68	0.085
13	2437.0	3.40	-16.51	-13.11	0.049	-17.52	-14.12	0.039	-10.58	0.088
14	2437.0	3.51	-16.77	-13.26	0.047	-17.55	-14.04	0.039	-10.62	0.087
15	2437.0	3.66	-16.82	-13.16	0.048	-17.68	-14.02	0.040	-10.56	0.088

Worst

Sample Calculation: Result = Duty factor + Reading

* The test was performed with condition that obtained the maximum Result(Antenna 0+1) power in pre-check.

UL Japan, Inc.

Shonan EMC Lab.

1-22-3 Megumigaoka, Hiratsuka-shi, Kanagawa-ken, 259-1220 JAPAN

Telephone : +81 463 50 6400

Facsimile : +81 463 50 6401

Average Output Power
(Reference data for RF Exposure / SAR testing)

Test place : Shonan EMC Lab. No.1 Measurement Room
Report No. : 11334871S-A-R1
Date : October 31, 2016
Temperature / Humidity : 24 deg. C / 44 % RH
Engineer : Kenichi Adachi
Mode : Tx OFDM, VHT40, MIMO

Antenna: 0 + Antenna: 1 (Burst power average) (Time average)

Ch	Freq. [MHz]	Ant: 0 Result [mW]	Ant: 1 Result [mW]	Ant: 0 Result [mW]	Ant: 1 Result [mW]	Result (Burst power average)		Result (Time average)	
						[dBm]	[mW]	[dBm]	[mW]
Low	2422.0	7.12	5.68	4.03	3.21	11.07	12.80	8.60	7.24
Mid	2437.0	7.00	5.68	3.97	3.21	11.03	12.68	8.56	7.18
High1	2452.0	6.99	5.75	3.96	3.26	11.05	12.74	8.59	7.22
High2	2457.0	7.20	5.79	4.08	3.28	11.14	12.99	8.67	7.36
High3	2462.0	3.75	3.16	2.12	1.79	8.39	6.91	5.92	3.91

Sample Calculation: Result [mW] = Antenna: 0 Result [mW] + Antenna: 1 Result [mW]

Antenna: 0 (* P/M: Power Meter with power sensor, AV: Average with gate trigger mode)

Ch	Freq. [MHz]	P/M (AV) Reading [dBm]	Cable Loss [dB]	Atten. Loss [dB]	Duty Factor [dB]	Result (Burst power average)		Result (Time average)	
						[dBm]	[mW]	[dBm]	[mW]
Low	2422.0	-15.61	1.43	20.23	2.47	8.52	7.12	6.05	4.03
Mid	2437.0	-15.69	1.44	20.23	2.47	8.45	7.00	5.98	3.97
High1	2452.0	-15.70	1.44	20.23	2.47	8.44	6.99	5.97	3.96
High2	2457.0	-15.57	1.44	20.23	2.47	8.57	7.20	6.10	4.08
High3	2462.0	-18.40	1.44	20.23	2.47	5.74	3.75	3.27	2.12

Antenna: 1 (* P/M: Power Meter with power sensor, AV: Average with gate trigger mode)

Ch	Freq. [MHz]	P/M (AV) Reading [dBm]	Cable Loss [dB]	Atten. Loss [dB]	Duty Factor [dB]	Result (Burst power average)		Result (Time average)	
						[dBm]	[mW]	[dBm]	[mW]
Low	2422.0	-16.52	1.36	20.23	2.47	7.54	5.68	5.07	3.21
Mid	2437.0	-16.53	1.37	20.23	2.47	7.54	5.68	5.07	3.21
High1	2452.0	-16.47	1.37	20.23	2.47	7.60	5.75	5.13	3.26
High2	2457.0	-16.44	1.37	20.23	2.47	7.63	5.79	5.16	3.28
High3	2462.0	-19.08	1.37	20.23	2.47	4.99	3.16	2.52	1.79

Sample Calculation:

Result = Reading + Cable Loss (including the cable(s) customer supplied) + Atten. Loss

[Pre check]

Mode (MCS)	Freq. [MHz]	Duty factor [dB]	Antenna: 0			Antenna: 1			Antenna- 0 + 1	
			Reading [dBm]	Result [dBm]	[mW]	Reading [dBm]	Result [dBm]	[mW]	Result [dBm]	[mW]
0	2437.0	1.02	-14.42	-13.40	0.046	-15.16	-14.14	0.039	-10.74	0.084
1	2437.0	1.65	-15.08	-13.43	0.045	-15.84	-14.19	0.038	-10.78	0.084
2	2437.0	2.12	-15.44	-13.32	0.047	-16.30	-14.18	0.038	-10.72	0.085
3	2437.0	2.47	-15.69	-13.22	0.048	-16.53	-14.06	0.039	-10.61	0.087
4	2437.0	2.88	-16.20	-13.32	0.047	-16.95	-14.07	0.039	-10.67	0.086
5	2437.0	3.25	-16.57	-13.32	0.047	-17.32	-14.07	0.039	-10.67	0.086
6	2437.0	3.37	-16.66	-13.29	0.047	-17.48	-14.11	0.039	-10.67	0.086
7	2437.0	3.46	-16.78	-13.32	0.047	-17.54	-14.08	0.039	-10.67	0.086
8	2437.0	3.65	-16.95	-13.30	0.047	-17.71	-14.06	0.039	-10.65	0.086
9	2437.0	3.76	-17.07	-13.31	0.047	-17.81	-14.05	0.039	-10.65	0.086

Worst

Sample Calculation: Result = Duty factor + Reading

* The test was performed with condition that obtained the maximum Result(Antenna 0+1) power in pre-check.

Average Output Power
(Reference data for RF Exposure / SAR testing)

Test place Shonan EMC Lab. No.1 Measurement Room
Report No. 11334871S-A-R1
Date November 11, 2016
Temperature / Humidity 25 deg. C / 33 % RH
Engineer Hikaru Shirasawa
Mode Tx BT LE

Freq. [MHz]	Reading [dBm]	Cable Loss [dB]	Atten. Loss [dB]	Result (Time average)		Duty factor [dB]	Result (Burst power average)	
				[dBm]	[mW]		[dBm]	[mW]
2402	-11.90	1.43	10.01	-0.46	0.90	1.78	1.32	1.36
2440	-11.77	1.44	10.01	-0.32	0.93	1.78	1.46	1.40
2480	-11.48	1.45	10.01	-0.02	1.00	1.78	1.76	1.50

Sample Calculation:

Result (Time average) = Reading + Cable Loss (including the cable(s) customer supplied) + Attenuator

Result (Burst power average) = Time average + Duty factor

*The equipment and cables were not used for factor 0 dB of the data sheets.

Burst rate confirmation
 (for Average output power)

Test place : Shonan EMC Lab. No.1 Measurement Room
 Report No. : 11334871S-A-R1
 Date : August 18, 2016
 Temperature / Humidity : 27 deg. C / 41 % RH
 Engineer : Hikaru Shirasawa
 Mode : Tx, SISO

11b, 5.5 Mbps

Tx on / (Tx on + Tx off) = 0.948
Tx on / (Tx on + Tx off) * 100 = 94.8 %
Duty factor = 10 * log (1.72 / 1.63) = 0.23 dB

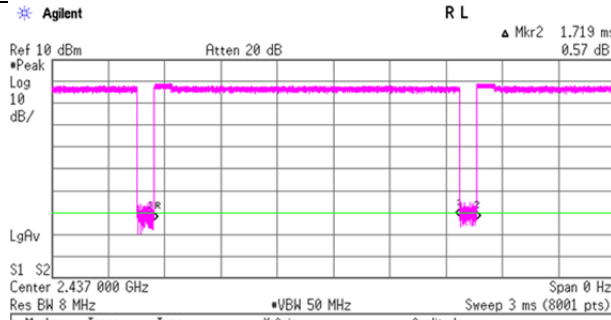

11g, 12 Mbps

Tx on / (Tx on + Tx off) = 0.881
Tx on / (Tx on + Tx off) * 100 = 88.1 %
Duty factor = 10 * log (0.82 / 0.73) = 0.55 dB

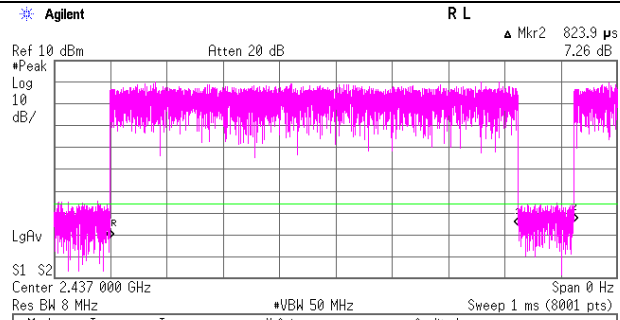

11g, 6 Mbps

Tx on / (Tx on + Tx off) = 0.937
Tx on / (Tx on + Tx off) * 100 = 93.7 %
Duty factor = 10 * log (1.53 / 1.43) = 0.28 dB

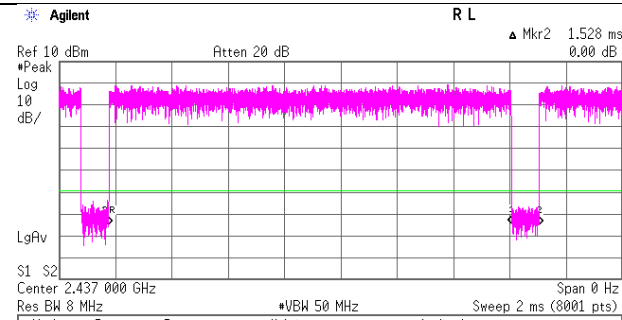

11n-20, SISO, MCS 3

Tx on / (Tx on + Tx off) = 0.789
Tx on / (Tx on + Tx off) * 100 = 78.9 %
Duty factor = 10 * log (0.46 / 0.37) = 1.03 dB

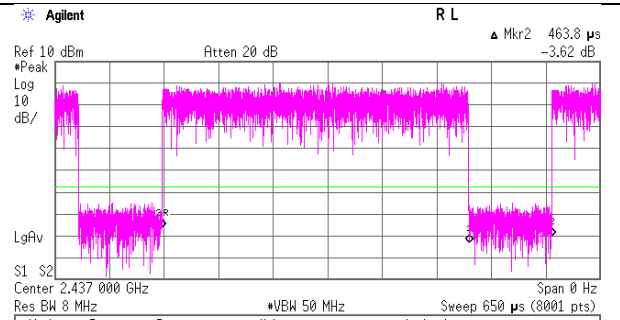

Burst rate confirmation
 (for Average output power)

Test place	Shonan EMC Lab. No.1 Measurement Room	
Report No.	11334871S-A-R1	
Date	August 18, 2016	August 19, 2016
Temperature / Humidity	27 deg. C / 41 % RH	26 deg. C / 43 % RH
Engineer	Hikaru Shirasawa	Kenichi Adachi
Mode	Tx	

OFDM VHT20, SISO, MCS 3

11n-40, SISO, MCS 3

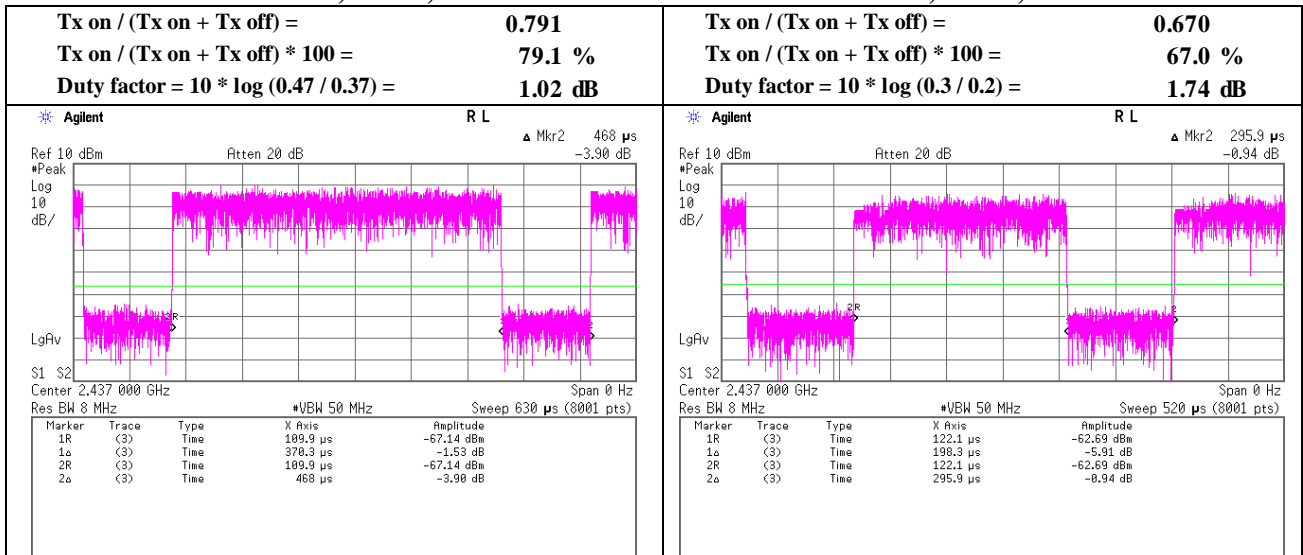

OFDM VHT40, SISO, MCS 3

11n-20, MIMO, MCS 11

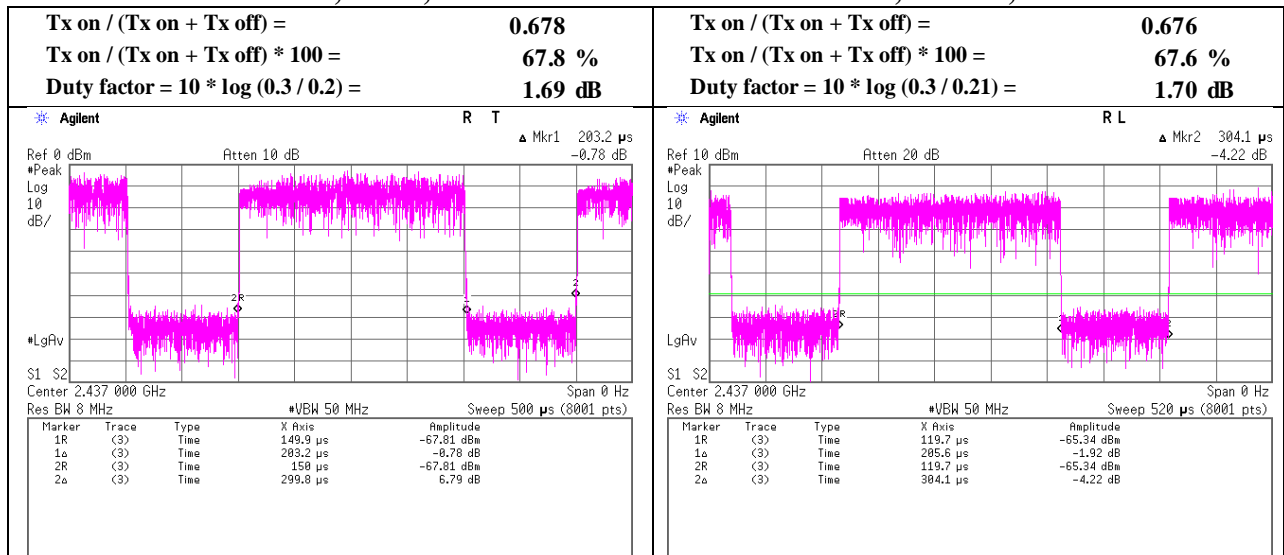

Burst rate confirmation
(for Average output power)

Test place	Shonan EMC Lab. No.1 Measurement Room		
Report No.	11334871S-A-R1		
Date	August 18, 2016	August 19, 2016	November 11, 2016
Temperature / Humidity	27 deg. C / 41 % RH	26 deg. C / 43 % RH	25 deg. C / 33 % RH
Engineer	Hikaru Shirasawa	Kenichi Adachi	Hikaru Shirasawa
Mode	Tx		

OFDM VHT20, MIMO, MCS 3

11n-40, MIMO, MCS 11

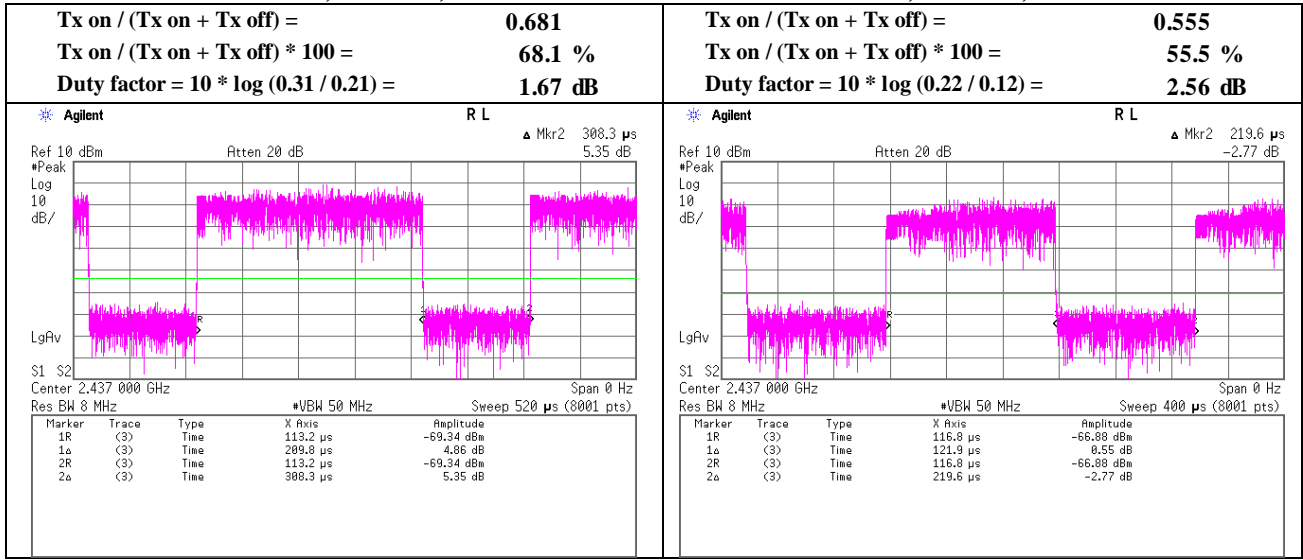

OFDM VHT40, MIMO, MCS 3

BT LE

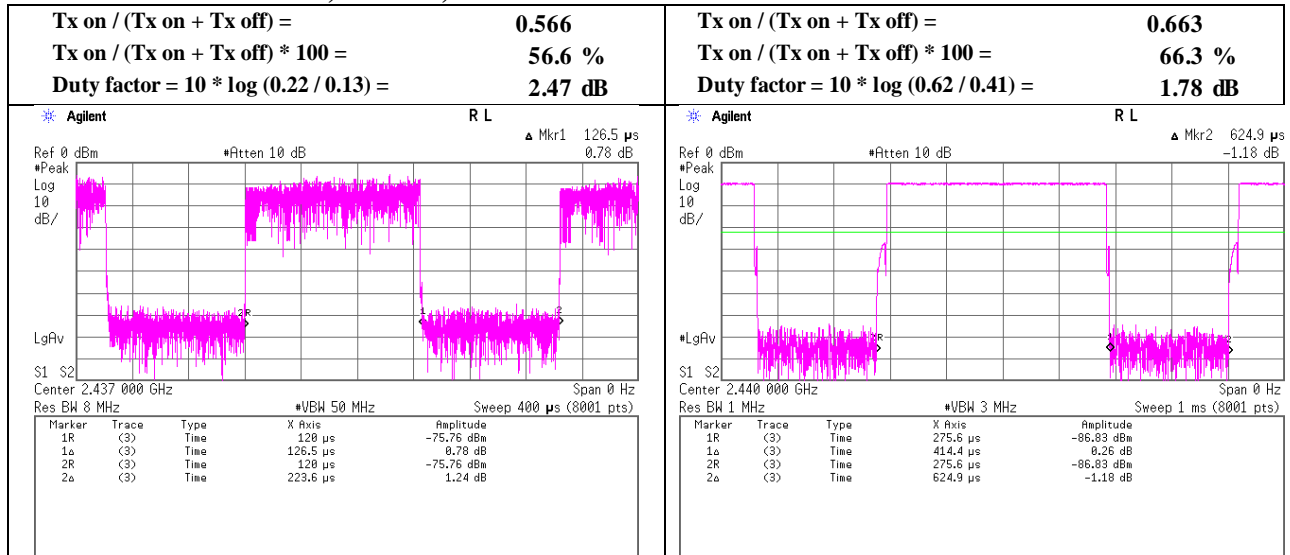

Burst rate confirmation
 (for Spurious emissions)

Test place : Shonan EMC Lab. No.1 Measurement Room
 Report No. : 11334871S-A-R1
 Date : August 18, 2016 August 19, 2016
 Temperature / Humidity : 27 deg. C / 41 % RH 26 deg. C / 43 % RH
 Engineer : Hikaru Shirasawa Kenichi Adachi
 Mode : Tx

11b, 11 Mbps

Tx on / (Tx on + Tx off) = 0.906
Tx on / (Tx on + Tx off) * 100 = 90.6 %
Duty factor = 20 * log (0.95 / 0.86) = 0.86 dB

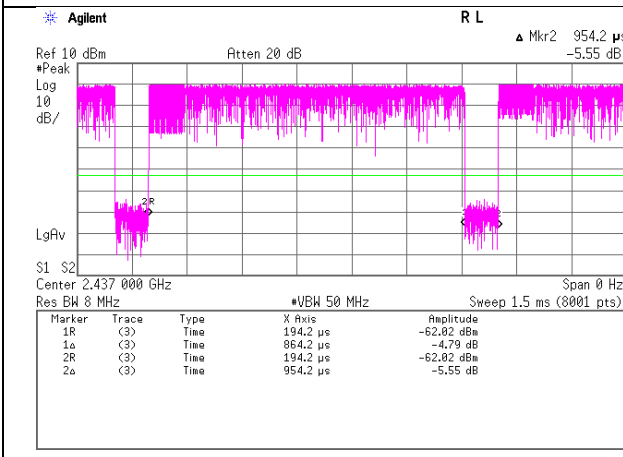

11n-20, SISO, MCS 3

Tx on / (Tx on + Tx off) = 0.789
Tx on / (Tx on + Tx off) * 100 = 78.9 %
Duty factor = 20 * log (0.46 / 0.37) = 2.06 dB

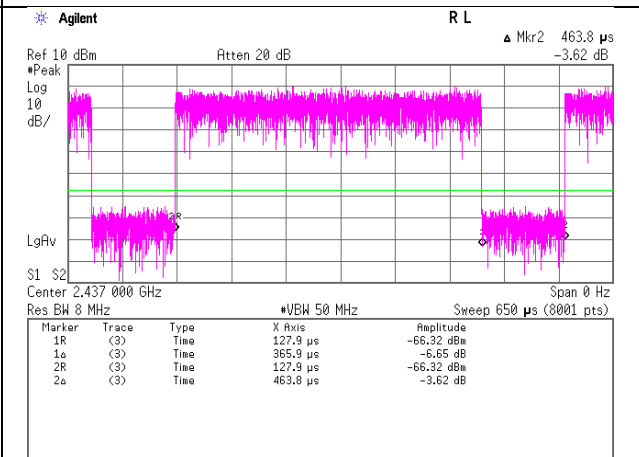

OFDM VHT20, MIMO, MCS 3

Tx on / (Tx on + Tx off) = 0.681
Tx on / (Tx on + Tx off) * 100 = 68.1 %
Duty factor = 20 * log (0.31 / 0.21) = 3.34 dB

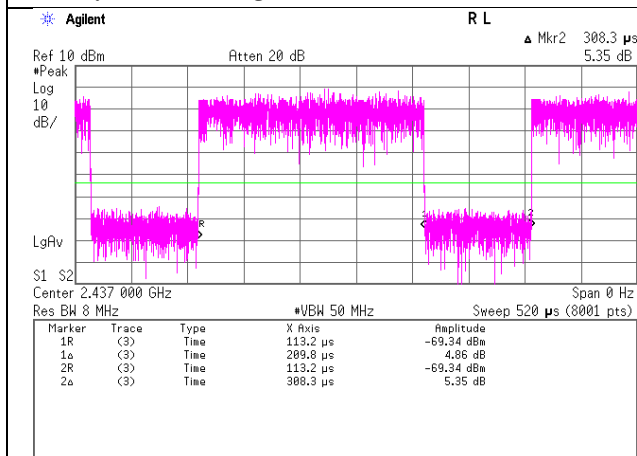

11n-40, SISO, MCS 3

Tx on / (Tx on + Tx off) = 0.670
Tx on / (Tx on + Tx off) * 100 = 67.0 %
Duty factor = 20 * log (0.3 / 0.2) = 3.48 dB

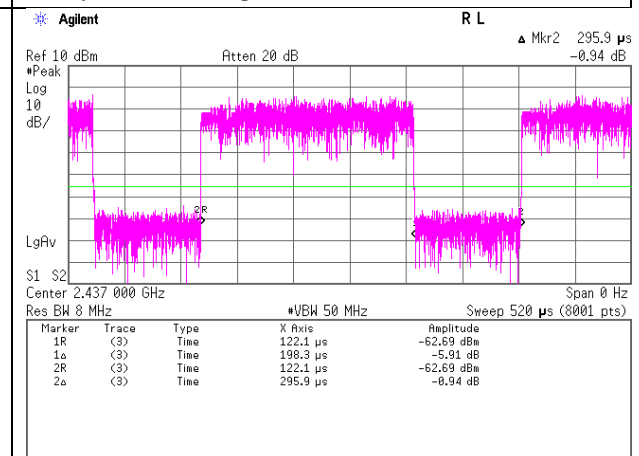

Burst rate confirmation (for Spurious emissions)

Test place : Shonan EMC Lab. No.1 Measurement Room
 Report No. : 11334871S-A-R1
 Date : August 19, 2016 November 8, 2016
 Temperature / Humidity : 26 deg. C / 43 % RH 22 deg. C / 28 %RH
 Engineer : Kenichi Adachi Hikaru Shirasawa
 Mode : Tx

11n-40, MIMO, MCS 11

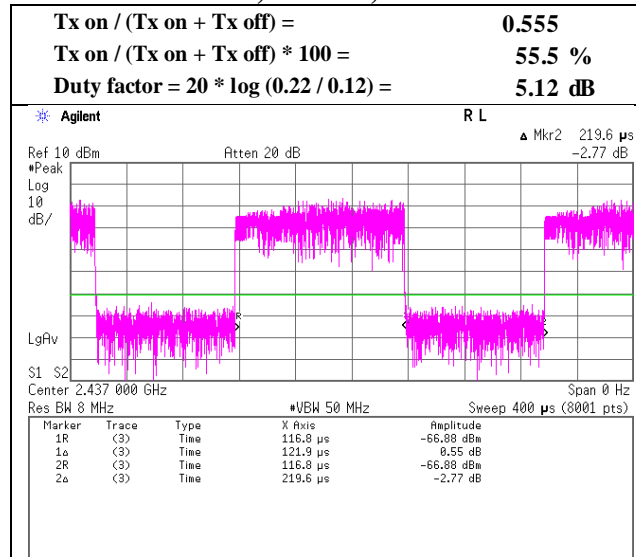

BT LE

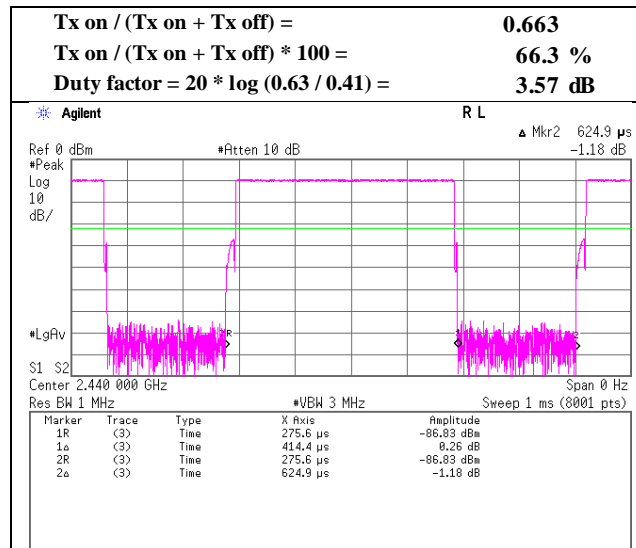

Averaging factor (Duty Factor)

Test place : Shonan EMC Lab. No.1 Measurement Room
 Report No. : 11334871S-A-R1
 Date : November 11, 2016
 Temperature / Humidity : 25 deg. C / 33 % RH
 Engineer : Hikaru Shirasawa
 Mode : Tx BT LE (Hopping on)

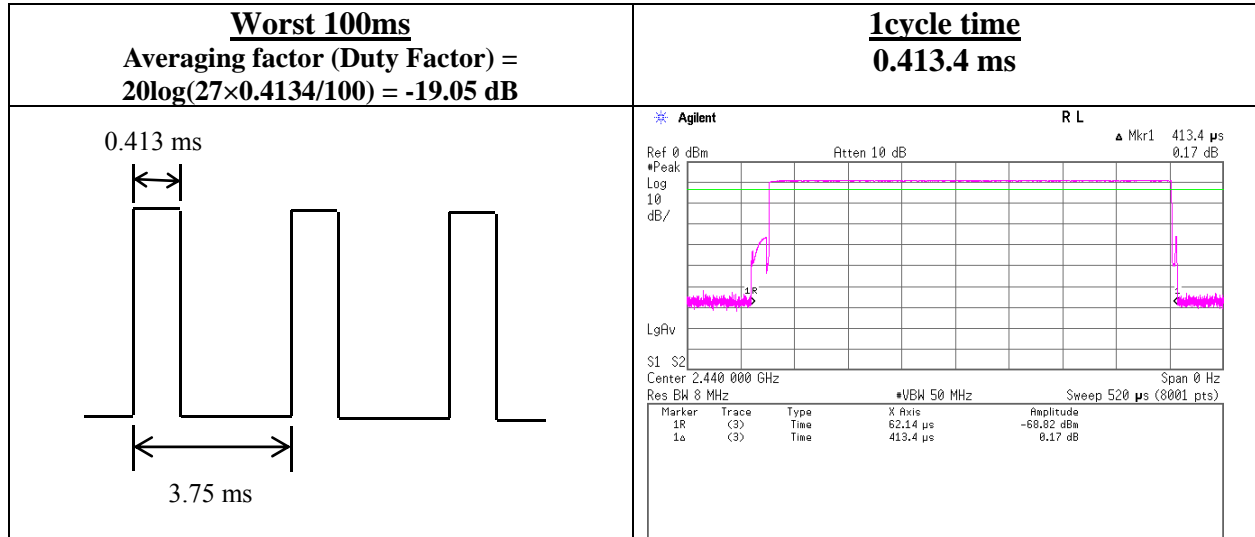

*Worst TX Duty cycle BLE is Advertising mode which max on time is 0.413 ms and Min interval is 3.75 ms
 (Refer to BLE Worst TX Duty sheet).
 The actual measurement value was applied as Averaging factor (Duty Factor).

Radiated Spurious Emission

Test place : Shonan EMC Lab. No.3 Semi Anechoic Chamber
Report No. : 11334871S-A-R1
Date : August 22, 2016 October 19, 2016 October 26, 2016 November 10, 2016
Temperature / Humidity : 26 deg.C / 42 %RH 25 deg.C / 58 %RH 25 deg.C / 49 %RH 23 deg.C / 35 %RH
Engineer : Hikaru Shirasawa Kenichi Adachi Hikaru Shirasawa Shinichi Takano
 (1 GHz - 2.8 GHz) (2.8 GHz - 13 GHz) (13 GHz - 18 GHz) (18 GHz - 26 GHz)
Mode : Tx 11b, 2412 MHz

(* PK: Peak, AV: Average, QP: Quasi-Peak)

Polarity	Frequency [MHz]	Detector	Reading [dBuV]	Ant.Fac. [dB/m]	Loss [dB]	Gain [dB]	Distance Factor [dB]	Result [dBuV/m]	Limit [dBuV/m]	Margin [dB]	Height [cm]	Angle [deg]	Remark
Hori.	2390.000	PK	47.51	27.41	13.82	40.70	2.28	50.32	73.90	23.5	106	280	
Hori.	4824.000	PK	49.26	31.17	6.01	36.53	2.28	52.19	73.90	21.7	248	147	
Hori.	7236.000	PK	43.89	36.52	7.56	36.59	2.28	53.66	73.90	20.2	155	12	
Hori.	9648.000	PK	43.98	38.66	8.43	36.52	2.28	56.83	73.90	17.0	201	218	
Hori.	14472.000	PK	46.65	41.47	10.36	34.63	-9.54	54.31	73.90	19.5	150	0	
Vert.	2390.000	PK	47.48	27.41	13.82	40.70	2.28	50.29	73.90	23.6	112	162	
Vert.	4824.000	PK	51.18	31.17	6.01	36.53	2.28	54.11	73.90	19.7	137	158	
Vert.	7236.000	PK	43.87	36.52	7.56	36.59	2.28	53.64	73.90	20.2	169	203	
Vert.	9648.000	PK	43.68	38.66	8.43	36.52	2.28	56.53	73.90	17.3	123	165	
Vert.	14472.000	PK	46.00	41.47	10.36	34.63	-9.54	53.66	73.90	20.2	150	0	

Result = Reading + Ant.Fac. + Loss (Cable+(Attenuator or Filter)(below 18 GHz)) - Gain(Amplifier) + Distance factor
Distance factor : 1 GHz - 13 GHz : 20log(3.90 m / 3.0 m) = 2.28 dB
13 GHz - 40 GHz : 20log(1.0 m / 3.0 m) = -9.54 dB

Average measurement value with duty factor

Polarity	Frequency [MHz]	Detector	Reading [dBuV]	Ant.Fac. [dB/m]	Loss [dB]	Gain [dB]	Duty Factor [dB]	Distance Factor [dB]	Result [dBuV/m]	Limit [dBuV/m]	Margin [dB]	Remark
Hori.	2390.000	AV	37.74	27.41	13.82	40.70	0.86	2.28	41.41	53.90	12.5	*1)
Hori.	4824.000	AV	38.69	31.17	6.01	36.53	0.86	2.28	42.48	53.90	11.4	
Hori.	7236.000	AV	34.26	36.52	7.56	36.59	0.86	2.28	44.89	53.90	9.0	
Hori.	9648.000	AV	35.17	38.66	8.43	36.52	0.86	2.28	48.88	53.90	5.0	
Hori.	14472.000	AV	36.91	41.47	10.36	34.63	0.86	-9.54	45.43	53.90	8.5	
Vert.	2390.000	AV	38.07	27.41	13.82	40.70	0.86	2.28	41.74	53.90	12.2	*1)
Vert.	4824.000	AV	41.20	31.17	6.01	36.53	0.86	2.28	44.99	53.90	8.9	
Vert.	7236.000	AV	34.42	36.52	7.56	36.59	0.86	2.28	45.05	53.90	8.9	
Vert.	9648.000	AV	33.95	38.66	8.43	36.52	0.86	2.28	47.66	53.90	6.2	
Vert.	14472.000	AV	37.02	41.47	10.36	34.63	0.86	-9.54	45.54	53.90	8.4	

Result = Reading + Ant.Fac. + Loss (Cable+(Attenuator or Filter)(below 18 GHz)) - Gain(Amplifier) + Duty factor + Distance factor
Distance factor : 1 GHz - 13 GHz : 20log(3.90 m / 3.0 m) = 2.28 dB
13 GHz - 40 GHz : 20log(1.0 m / 3.0 m) = -9.54 dB

Duty factor refer to "Duty factor Calculation chart" sheet.

*1) Not out of band emission (Leakage Power)

20 dBc Data Sheet (RBW 100 kHz, VBW 300 kHz)

Polarity	Frequency [MHz]	Detector	Reading [dBuV]	Ant.Fac. [dB/m]	Loss [dB]	Gain [dB]	Distance Factor [dB]	Result [dBuV/m]	Limit [dBuV/m]	Margin [dB]	Remark
Hori.	2412.000	PK	89.06	27.41	13.84	40.70	2.28	91.89	-	-	Carrier
Hori.	2400.000	PK	42.73	27.41	13.83	40.70	2.28	45.55	71.89	26.3	
Vert.	2412.000	PK	89.40	27.41	13.84	40.70	2.28	92.23	-	-	Carrier
Vert.	2400.000	PK	42.22	27.41	13.83	40.70	2.28	45.04	72.23	27.2	

Result = Reading + Ant.Fac. + Loss (Cable+(Attenuator or Filter)(below 18 GHz)) - Gain(Amplifier) + Distance factor
Distance factor : 1 GHz - 13 GHz : 20log(3.90 m / 3.0 m) = 2.28 dB
13 GHz - 40 GHz : 20log(1.0 m / 3.0 m) = -9.54 dB

Radiated Spurious Emission
(Reference Plot for band-edge)

Test place : Shonan EMC Lab. No.3 Semi Anechoic Chamber
Report No. : 11334871S-A-R1
Date : August 22, 2016
Temperature / Humidity : 26 deg.C / 42 %RH
Engineer : Hikaru Shirasawa
Mode : Tx 11b, 2412 MHz

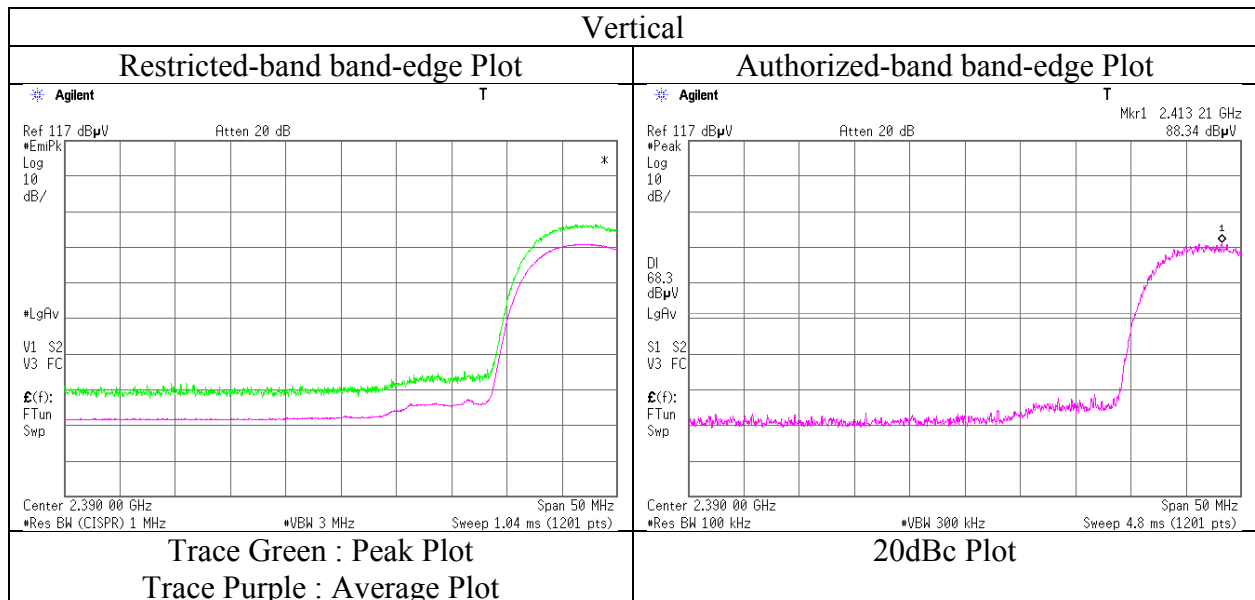
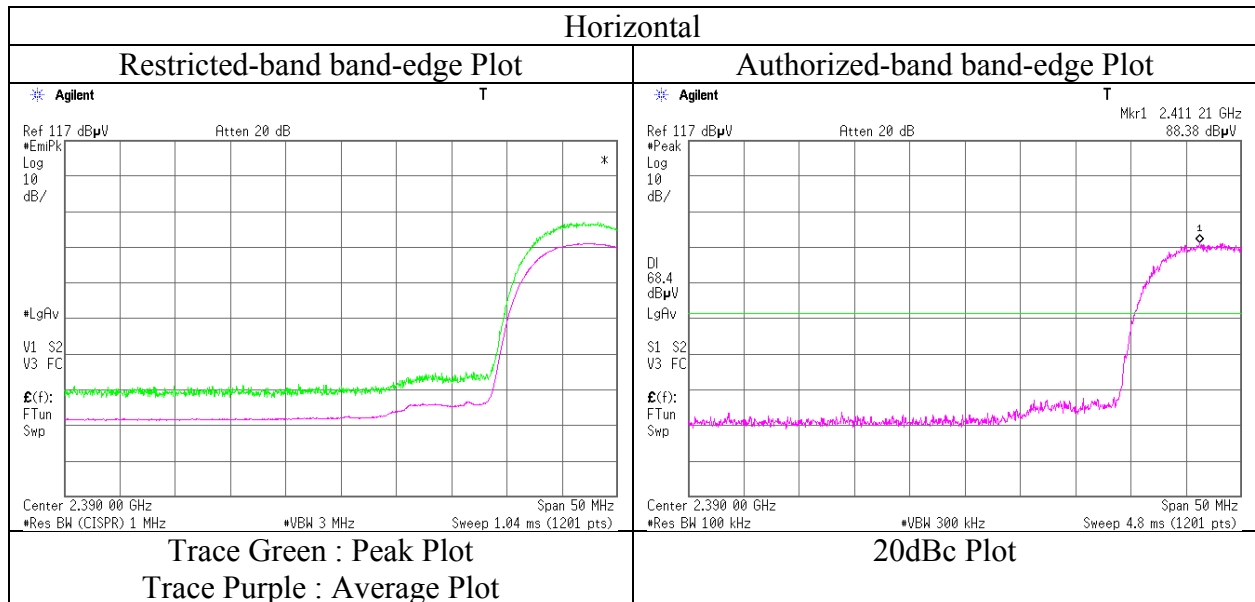

* Final result of restricted band edge was shown in tabular data.

Radiated Spurious Emission

Test place : Shonan EMC Lab. No.3 Semi Anechoic Chamber
Report No. : 11334871S-A-R1
Date : August 22, 2016 October 19, 2016 October 26, 2016 November 10, 2016
Temperature / Humidity : 26 deg.C / 42 %RH 25 deg.C / 58 %RH 25 deg.C / 49 %RH 23 deg.C / 35 %RH
Engineer : Hikaru Shirasawa Kenichi Adachi Hikaru Shirasawa Shinichi Takano
(1 GHz - 2.8 GHz) (2.8 GHz - 13 GHz) (13 GHz - 18 GHz) (18 GHz - 26 GHz)
Mode : Tx 11b, 2437 MHz

(* PK: Peak, AV: Average, QP: Quasi-Peak)

Polarity	Frequency [MHz]	Detector	Reading [dBuV]	Ant.Fac. [dB/m]	Loss [dB]	Gain [dB]	Distance Factor [dB]	Result [dBuV/m]	Limit [dBuV/m]	Margin [dB]	Height [cm]	Angle [deg]	Remark
Hori.	4874.000	PK	47.99	31.28	6.02	36.53	2.28	51.04	73.90	22.8	242	152	
Hori.	7311.000	PK	43.99	36.74	7.59	36.64	2.28	53.96	73.90	19.9	153	10	
Hori.	9748.000	PK	45.67	38.74	8.48	36.49	2.28	58.68	73.90	15.2	198	204	
Hori.	14622.000	PK	46.46	41.40	10.43	34.76	-9.54	53.99	73.90	19.9	150	0	
Vert.	4874.000	PK	49.28	31.28	6.02	36.53	2.28	52.33	73.90	21.5	134	161	
Vert.	7311.000	PK	43.89	36.74	7.59	36.64	2.28	53.86	73.90	20.0	166	201	
Vert.	9748.000	PK	45.48	38.74	8.48	36.49	2.28	58.49	73.90	15.4	125	168	
Vert.	14622.000	PK	45.42	41.40	10.43	34.76	-9.54	52.95	73.90	20.9	150	0	

Result = Reading + Ant.Fac. + Loss (Cable+(Attenuator or Filter)(below 18 GHz)) - Gain(Amplifier) + Distance factor

Distance factor : 1 GHz - 13 GHz : $20\log(3.90\text{ m} / 3.0\text{ m}) = 2.28\text{ dB}$

13 GHz - 40 GHz : $20\log(1.0\text{ m} / 3.0\text{ m}) = -9.54\text{ dB}$

Average measurement value with duty factor

Polarity	Frequency [MHz]	Detector	Reading [dBuV]	Ant.Fac. [dB/m]	Loss [dB]	Gain [dB]	Duty Factor [dB]	Distance Factor [dB]	Result [dBuV/m]	Limit [dBuV/m]	Margin [dB]	Remark
Hori.	4874.000	AV	38.46	31.28	6.02	36.53	0.86	2.28	42.37	53.90	11.5	
Hori.	7311.000	AV	33.98	36.74	7.59	36.64	0.86	2.28	44.81	53.90	9.1	
Hori.	9748.000	AV	35.99	38.74	8.48	36.49	0.86	2.28	49.86	53.90	4.0	
Hori.	14622.000	AV	36.42	41.40	10.43	34.76	0.86	-9.54	44.81	53.90	9.1	
Vert.	4874.000	AV	38.11	31.28	6.02	36.53	0.86	2.28	42.02	53.90	11.9	
Vert.	7311.000	AV	33.85	36.74	7.59	36.64	0.86	2.28	44.68	53.90	9.2	
Vert.	9748.000	AV	35.56	38.74	8.48	36.49	0.86	2.28	49.43	53.90	4.5	
Vert.	14622.000	AV	36.55	41.40	10.43	34.76	0.86	-9.54	44.94	53.90	9.0	

Result = Reading + Ant.Fac. + Loss (Cable+(Attenuator or Filter)(below 18 GHz)) - Gain(Amplifier) + Duty factor + Distance factor

Distance factor : 1 GHz - 13 GHz : $20\log(3.90\text{ m} / 3.0\text{ m}) = 2.28\text{ dB}$

13 GHz - 40 GHz : $20\log(1.0\text{ m} / 3.0\text{ m}) = -9.54\text{ dB}$

Duty factor refer to "Duty factor Calculation chart" sheet.

Radiated Spurious Emission

Test place : Shonan EMC Lab. No.3 Semi Anechoic Chamber
Report No. : 11334871S-A-R1
Date : August 22, 2016 October 19, 2016 October 26, 2016 November 10, 2016
Temperature / Humidity : 26 deg.C / 42 %RH 25 deg.C / 58 %RH 25 deg.C / 49 %RH 23 deg.C / 35 %RH
Engineer : Hikaru Shirasawa Kenichi Adachi Hikaru Shirasawa Shinichi Takano
(1 GHz - 2.8 GHz) (2.8 GHz - 13 GHz) (13 GHz - 18 GHz) (18 GHz - 26 GHz)
Mode : Tx 11b, 2462 MHz

(* PK: Peak, AV: Average, QP: Quasi-Peak)

Polarity	Frequency [MHz]	Detector	Reading [dBuV]	Ant.Fac. [dB/m]	Loss [dB]	Gain [dB]	Distance Factor [dB]	Result [dBuV/m]	Limit [dBuV/m]	Margin [dB]	Height [cm]	Angle [deg]	Remark
Hori.	2483.500	PK	45.62	27.39	13.91	40.69	2.28	48.51	73.90	25.3	113	284	
Hori.	4924.000	PK	45.11	31.38	6.04	36.52	2.28	48.29	73.90	25.6	244	157	
Hori.	7386.000	PK	43.86	36.95	7.60	36.69	2.28	54.00	73.90	19.9	162	18	
Hori.	9848.000	PK	43.91	38.81	8.54	36.45	2.28	57.09	73.90	16.8	203	213	
Hori.	14772.000	PK	45.20	41.33	10.53	34.88	-9.54	52.64	73.90	21.2	150	0	
Vert.	2483.500	PK	47.49	27.39	13.91	40.69	2.28	50.38	73.90	23.5	101	203	
Vert.	4924.000	PK	46.48	31.38	6.04	36.52	2.28	49.66	73.90	24.2	133	157	
Vert.	7386.000	PK	43.64	36.95	7.60	36.69	2.28	53.78	73.90	20.1	165	207	
Vert.	9848.000	PK	43.55	38.81	8.54	36.45	2.28	56.73	73.90	17.1	127	162	
Vert.	14772.000	PK	44.83	41.33	10.53	34.88	-9.54	52.27	73.90	21.6	150	0	

Result = Reading + Ant.Fac. + Loss (Cable+(Attenuator or Filter)(below 18 GHz)) - Gain(Amplifier) + Distance factor

Distance factor : 1 GHz - 13 GHz : 20log(3.90 m / 3.0 m) = 2.28 dB

13 GHz - 40 GHz : 20log(1.0 m / 3.0 m) = -9.54 dB

Average measurement value with duty factor

Polarity	Frequency [MHz]	Detector	Reading [dBuV]	Ant.Fac. [dB/m]	Loss [dB]	Gain [dB]	Duty Factor [dB]	Distance Factor [dB]	Result [dBuV/m]	Limit [dBuV/m]	Margin [dB]	Remark
Hori.	2483.500	AV	37.67	27.39	13.91	40.69	0.86	2.28	41.42	53.90	12.5	*1)
Hori.	4924.000	AV	35.02	31.38	6.04	36.52	0.86	2.28	39.06	53.90	14.8	
Hori.	7386.000	AV	34.02	36.95	7.60	36.69	0.86	2.28	45.02	53.90	8.9	
Hori.	9848.000	AV	34.21	38.81	8.54	36.45	0.86	2.28	48.25	53.90	5.7	
Hori.	14772.000	AV	35.79	41.33	10.53	34.88	0.86	-9.54	44.09	53.90	9.8	
Vert.	2483.500	AV	38.65	27.39	13.91	40.69	0.86	2.28	42.40	53.90	11.5	*1)
Vert.	4924.000	AV	36.23	31.38	6.04	36.52	0.86	2.28	40.27	53.90	13.6	
Vert.	7386.000	AV	33.78	36.95	7.60	36.69	0.86	2.28	44.78	53.90	9.1	
Vert.	9848.000	AV	33.78	38.81	8.54	36.45	0.86	2.28	47.82	53.90	6.1	
Vert.	14772.000	AV	35.89	41.33	10.53	34.88	0.86	-9.54	44.19	53.90	9.7	

Result = Reading + Ant.Fac. + Loss (Cable+(Attenuator or Filter)(below 18 GHz)) - Gain(Amplifier) + Duty factor + Distance factor

Distance factor : 1 GHz - 13 GHz : 20log(3.90 m / 3.0 m) = 2.28 dB

13 GHz - 40 GHz : 20log(1.0 m / 3.0 m) = -9.54 dB

Duty factor refer to "Duty factor Calculation chart" sheet.

*1) Not out of band emission (Leakage Power)

Radiated Spurious Emission
(Reference Plot for band-edge)

Test place : Shonan EMC Lab. No.3 Semi Anechoic Chamber
Report No. : 11334871S-A-R1
Date : August 22, 2016
Temperature / Humidity : 26 deg.C / 42 %RH
Engineer : Hikaru Shirasawa
Mode : Tx 11b, 2462 MHz

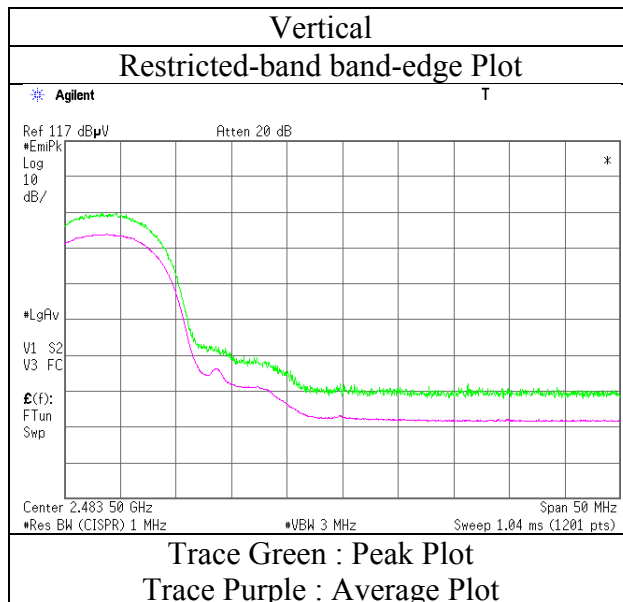
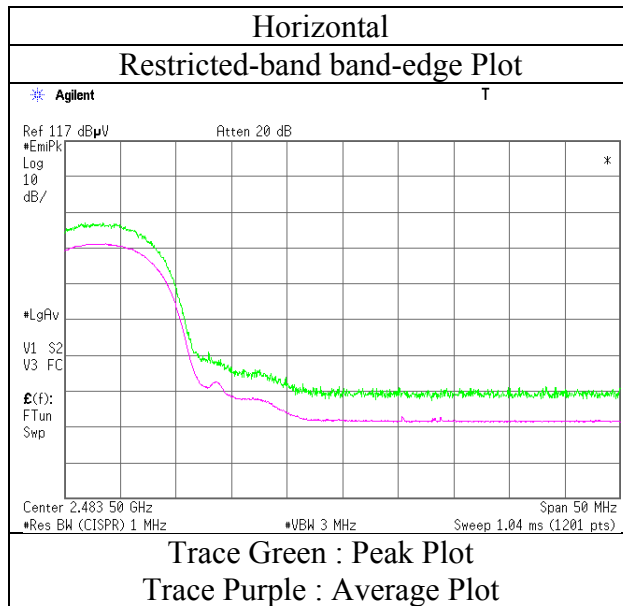

* Final result of restricted band edge was shown in tabular data.

Radiated Spurious Emission

Test place : Shonan EMC Lab. No.3 Semi Anechoic Chamber
Report No. : 11334871S-A-R1
Date : August 22, 2016 October 19, 2016 October 26, 2016 November 10, 2016
Temperature / Humidity : 26 deg.C / 42 %RH 25 deg.C / 58 %RH 25 deg.C / 49 %RH 23 deg.C / 35 %RH
Engineer : Hikaru Shirasawa Kenichi Adachi Hikaru Shirasawa Shinichi Takano
 (1 GHz - 2.8 GHz) (2.8 GHz - 13 GHz) (13 GHz - 18 GHz) (18 GHz - 26 GHz)
Mode : Tx 11b, 2467 MHz

(* PK: Peak, AV: Average, QP: Quasi-Peak)

Polarity	Frequency [MHz]	Detector	Reading [dBuV]	Ant.Fac. [dB/m]	Loss [dB]	Gain [dB]	Distance Factor [dB]	Result [dBuV/m]	Limit [dBuV/m]	Margin [dB]	Height [cm]	Angle [deg]	Remark
Hori.	2483.500	PK	45.96	27.39	13.91	40.69	2.28	48.85	73.90	25.0	146	273	
Hori.	4934.000	PK	43.78	31.40	6.05	36.52	2.28	46.99	73.90	26.9	232	152	
Hori.	7401.000	PK	43.69	37.00	7.61	36.70	2.28	53.88	73.90	20.0	150	0	
Hori.	9868.000	PK	43.46	38.83	8.55	36.44	2.28	56.68	73.90	17.2	150	0	
Hori.	14802.000	PK	45.53	41.31	10.56	34.90	-9.54	52.96	73.90	20.9	150	0	
Vert.	2483.500	PK	45.91	27.39	13.91	40.69	2.28	48.80	73.90	25.1	120	208	
Vert.	4934.000	PK	43.85	31.40	6.05	36.52	2.28	47.06	73.90	26.8	136	147	
Vert.	7401.000	PK	43.62	37.00	7.61	36.70	2.28	53.81	73.90	20.0	150	0	
Vert.	9868.000	PK	43.44	38.83	8.55	36.44	2.28	56.66	73.90	17.2	150	0	
Vert.	14802.000	PK	44.52	41.31	10.56	34.90	-9.54	51.95	73.90	21.9	150	0	

Result = Reading + Ant.Fac. + Loss (Cable+(Attenuator or Filter)(below 18 GHz)) - Gain(Amplifier) + Distance factor

Distance factor : 1 GHz - 13 GHz : 20log(3.90 m / 3.0 m) = 2.28 dB

13 GHz - 40 GHz : 20log(1.0 m / 3.0 m) = -9.54 dB

Average measurement value with duty factor

Polarity	Frequency [MHz]	Detector	Reading [dBuV]	Ant.Fac. [dB/m]	Loss [dB]	Gain [dB]	Duty Factor [dB]	Distance Factor [dB]	Result [dBuV/m]	Limit [dBuV/m]	Margin [dB]	Remark
Hori.	2483.500	AV	36.76	27.39	13.91	40.69	0.86	2.28	40.51	53.90	13.4	*1)
Hori.	4934.000	AV	33.64	31.40	6.05	36.52	0.86	2.28	37.71	53.90	16.2	
Hori.	7401.000	AV	33.55	37.00	7.61	36.70	0.86	2.28	44.60	53.90	9.3	
Hori.	9868.000	AV	33.66	38.83	8.55	36.44	0.86	2.28	47.74	53.90	6.2	
Hori.	14802.000	AV	35.79	41.31	10.56	34.90	0.86	-9.54	44.08	53.90	9.8	
Vert.	2483.500	AV	37.06	27.39	13.91	40.69	0.86	2.28	40.81	53.90	13.1	*1)
Vert.	4934.000	AV	33.78	31.40	6.05	36.52	0.86	2.28	37.85	53.90	16.1	
Vert.	7401.000	AV	33.46	37.00	7.61	36.70	0.86	2.28	44.51	53.90	9.4	
Vert.	9868.000	AV	33.56	38.83	8.55	36.44	0.86	2.28	47.64	53.90	6.3	
Vert.	14802.000	AV	35.95	41.31	10.56	34.90	0.86	-9.54	44.24	53.90	9.7	

Result = Reading + Ant.Fac. + Loss (Cable+(Attenuator or Filter)(below 18 GHz)) - Gain(Amplifier) + Duty factor + Distance factor

Distance factor : 1 GHz - 13 GHz : 20log(3.90 m / 3.0 m) = 2.28 dB

13 GHz - 40 GHz : 20log(1.0 m / 3.0 m) = -9.54 dB

Duty factor refer to "Duty factor Calculation chart" sheet.

*1) Not out of band emission (Leakage Power)

Radiated Spurious Emission
(Reference Plot for band-edge)

Test place	Shonan EMC Lab. No.3 Semi Anechoic Chamber
Report No.	11334871S-A-R1
Date	August 22, 2016
Temperature / Humidity	26 deg.C / 42 %RH
Engineer	Hikaru Shirasawa
Mode	Tx 11b, 2467 MHz

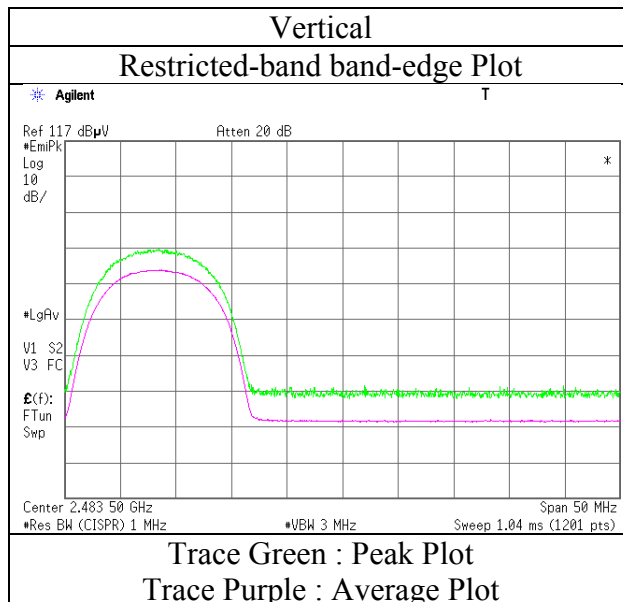
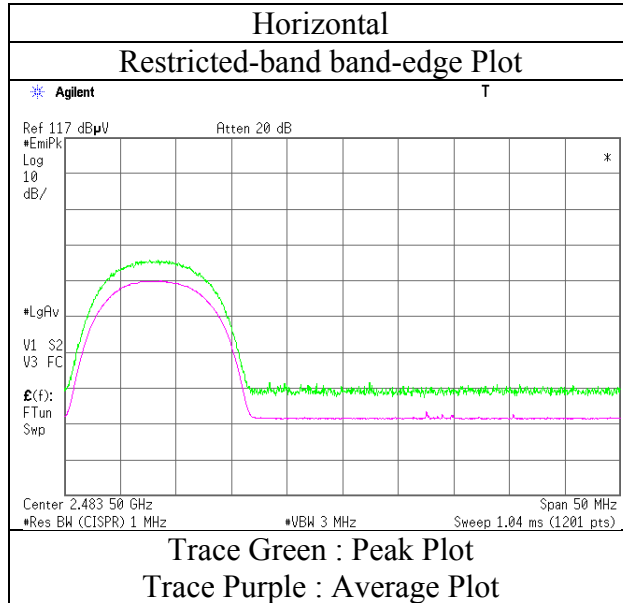

* Final result of restricted band edge was shown in tabular data.

Radiated Spurious Emission

Test place : Shonan EMC Lab. No.3 Semi Anechoic Chamber
Report No. : 11334871S-A-R1
Date : August 22, 2016 October 19, 2016 October 26, 2016 November 10, 2016
Temperature / Humidity : 26 deg.C / 42 %RH 25 deg.C / 58 %RH 25 deg.C / 49 %RH 23 deg.C / 35 %RH
Engineer : Hikaru Shirasawa Kenichi Adachi Hikaru Shirasawa Shinichi Takano
 (1 GHz - 2.8 GHz) (2.8 GHz - 13 GHz) (13 GHz - 18 GHz) (18 GHz - 26 GHz)
Mode : Tx 11b, 2472 MHz

(* PK: Peak, AV: Average, QP: Quasi-Peak)

Polarity	Frequency [MHz]	Detector	Reading [dBuV]	Ant.Fac. [dB/m]	Loss [dB]	Gain [dB]	Distance Factor [dB]	Result [dBuV/m]	Limit [dBuV/m]	Margin [dB]	Height [cm]	Angle [deg]	Remark
Hori.	2483.500	PK	46.22	27.39	13.91	40.69	2.28	49.11	73.90	24.7	100	71	
Hori.	4944.000	PK	43.38	31.42	6.05	36.52	2.28	46.61	73.90	27.2	150	0	
Hori.	7416.000	PK	43.59	37.04	7.61	36.71	2.28	53.81	73.90	20.0	150	0	
Hori.	9888.000	PK	43.13	38.84	8.56	36.43	2.28	56.38	73.90	17.5	150	0	
Hori.	14832.000	PK	45.92	41.30	10.58	34.93	-9.54	53.33	73.90	20.5	150	0	
Vert.	2483.500	PK	46.12	27.39	13.91	40.69	2.28	49.01	73.90	24.8	151	219	
Vert.	4944.000	PK	43.33	31.42	6.05	36.52	2.28	46.56	73.90	27.3	150	0	
Vert.	7416.000	PK	43.65	37.04	7.61	36.71	2.28	53.87	73.90	20.0	150	0	
Vert.	9888.000	PK	43.25	38.84	8.56	36.43	2.28	56.50	73.90	17.4	150	0	
Vert.	14832.000	PK	45.27	41.30	10.58	34.93	-9.54	52.68	73.90	21.2	150	0	

Result = Reading + Ant.Fac. + Loss (Cable+(Attenuator or Filter)(below 18 GHz)) - Gain(Amplifier) + Distance factor

Distance factor : 1 GHz - 13 GHz : 20log(3.90 m / 3.0 m) = 2.28 dB

13 GHz - 40 GHz : 20log(1.0 m / 3.0 m) = -9.54 dB

Average measurement value with duty factor

Polarity	Frequency [MHz]	Detector	Reading [dBuV]	Ant.Fac. [dB/m]	Loss [dB]	Gain [dB]	Duty Factor [dB]	Distance Factor [dB]	Result [dBuV/m]	Limit [dBuV/m]	Margin [dB]	Remark
Hori.	2483.500	AV	37.22	27.39	13.91	40.69	0.86	2.28	40.97	53.90	12.9	*1)
Hori.	4944.000	AV	33.58	31.42	6.05	36.52	0.86	2.28	37.67	53.90	16.2	
Hori.	7416.000	AV	33.64	37.04	7.61	36.71	0.86	2.28	44.72	53.90	9.2	
Hori.	9888.000	AV	33.75	38.84	8.56	36.43	0.86	2.28	47.86	53.90	6.0	
Hori.	14832.000	AV	36.21	41.30	10.58	34.93	0.86	-9.54	44.48	53.90	9.4	
Vert.	2483.500	AV	37.01	27.39	13.91	40.69	0.86	2.28	40.76	53.90	13.1	*1)
Vert.	4944.000	AV	33.54	31.42	6.05	36.52	0.86	2.28	37.63	53.90	16.3	
Vert.	7416.000	AV	33.69	37.04	7.61	36.71	0.86	2.28	44.77	53.90	9.1	
Vert.	9888.000	AV	33.79	38.84	8.56	36.43	0.86	2.28	47.90	53.90	6.0	
Vert.	14832.000	AV	35.92	41.30	10.58	34.93	0.86	-9.54	44.19	53.90	9.7	

Result = Reading + Ant.Fac. + Loss (Cable+(Attenuator or Filter)(below 18 GHz)) - Gain(Amplifier) + Duty factor + Distance factor

Distance factor : 1 GHz - 13 GHz : 20log(3.90 m / 3.0 m) = 2.28 dB

13 GHz - 40 GHz : 20log(1.0 m / 3.0 m) = -9.54 dB

Duty factor refer to "Duty factor Calculation chart" sheet.

*1) Not out of band emission (Leakage Power)

Radiated Spurious Emission
(Reference Plot for band-edge)

Test place	Shonan EMC Lab. No.3 Semi Anechoic Chamber
Report No.	11334871S-A-R1
Date	August 22, 2016
Temperature / Humidity	26 deg.C / 42 %RH
Engineer	Hikaru Shirasawa
Mode	Tx 11b, 2472 MHz

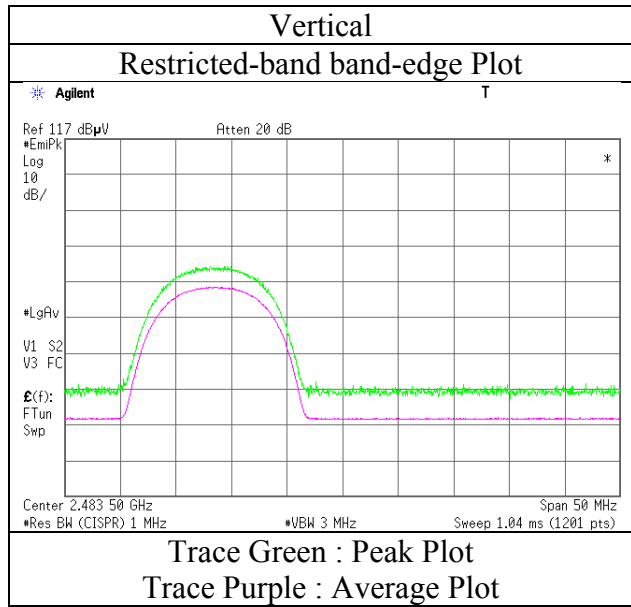
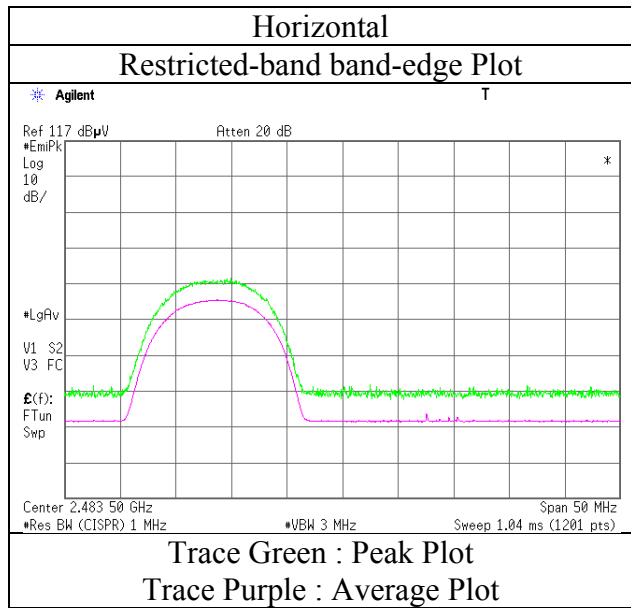

* Final result of restricted band edge was shown in tabular data.

Radiated Spurious Emission

Test place : Shonan EMC Lab. No.3 Semi Anechoic Chamber
Report No. : 11334871S-A-R1
Date : August 30, 2016 October 24, 2016 October 26, 2016 November 10, 2016
Temperature / Humidity : 22 deg.C / 70 %RH 25 deg.C / 58 %RH 25 deg.C / 49 %RH 23 deg.C / 35 %RH
Engineer : Makoto Hosaka Hikaru Shirasawa Hikaru Shirasawa Shinichi Takano
 (1 GHz - 2.8 GHz) (2.8 GHz - 13 GHz) (13 GHz - 18 GHz) (18 GHz - 26 GHz)
Mode : Tx OFDM, VHT20, MIMO, 2412 MHz

(* PK: Peak, AV: Average, QP: Quasi-Peak)

Polarity	Frequency [MHz]	Detector	Reading [dBuV]	Ant.Fac. [dB/m]	Loss [dB]	Gain [dB]	Distance Factor [dB]	Result [dBuV/m]	Limit [dBuV/m]	Margin [dB]	Height [cm]	Angle [deg]	Remark
Hori.	2261.231	PK	51.68	26.88	13.70	40.71	2.28	53.83	73.90	20.0	126	148	
Hori.	2261.245	PK	46.69	26.88	13.70	36.89	2.28	52.66	73.90	21.2	153	83	
Hori.	2390.000	PK	54.82	27.41	13.82	40.70	2.28	57.63	73.90	16.2	127	39	
Hori.	4824.000	PK	44.77	31.17	6.01	36.53	2.28	47.70	73.90	26.2	150	130	
Hori.	7436.000	PK	45.24	37.10	7.63	36.73	2.28	55.52	73.90	18.3	150	0	
Hori.	14472.000	PK	46.28	41.47	10.36	34.63	-9.54	53.94	73.90	19.9	150	0	
Vert.	2261.231	PK	51.78	26.88	13.70	40.71	2.28	53.93	73.90	19.9	122	136	
Vert.	2261.245	PK	48.88	26.88	13.70	36.89	2.28	54.85	73.90	19.0	198	190	
Vert.	2390.000	PK	57.83	27.41	13.82	40.70	2.28	60.64	73.90	13.2	132	90	
Vert.	4824.000	PK	47.84	31.17	6.01	36.53	2.28	50.77	73.90	23.1	157	180	
Vert.	7436.000	PK	45.48	37.10	7.63	36.73	2.28	55.76	73.90	18.1	150	359	
Vert.	14472.000	PK	46.81	41.47	10.36	34.63	-9.54	54.47	73.90	19.4	150	0	

Result = Reading + Ant.Fac. + Loss (Cable+(Attenuator or Filter)(below 18 GHz)) - Gain(Amplifier) + Distance factor

Distance factor : 1 GHz - 13 GHz : 20log(3.90 m / 3.0 m) = 2.28 dB

13 GHz - 40 GHz : 20log(1.0 m / 3.0 m) = -9.54 dB

Average measurement value with duty factor

Polarity	Frequency [MHz]	Detector	Reading [dBuV]	Ant.Fac. [dB/m]	Loss [dB]	Gain [dB]	Duty Factor [dB]	Distance Factor [dB]	Result [dBuV/m]	Limit [dBuV/m]	Margin [dB]	Remark
Hori.	2261.231	AV	45.38	26.88	13.70	40.71	3.34	2.28	50.87	53.90	3.0	
Hori.	2261.245	AV	37.57	26.88	13.70	36.89	3.34	2.28	46.88	53.90	7.0	
Hori.	2390.000	AV	42.33	27.41	13.82	40.70	3.34	2.28	48.48	53.90	5.4	*1)
Hori.	4824.000	AV	35.37	31.17	6.01	36.53	3.34	2.28	41.64	53.90	12.3	
Hori.	7436.000	AV	35.08	37.10	7.63	36.73	3.34	2.28	48.70	53.90	5.2	
Hori.	14472.000	AV	37.06	41.47	10.36	34.63	3.34	-9.54	48.06	53.90	5.8	
Vert.	2261.231	AV	45.41	26.88	13.70	40.71	3.34	2.28	50.90	53.90	3.0	
Vert.	2261.245	AV	41.68	26.88	13.70	36.89	3.34	2.28	50.99	53.90	2.9	
Vert.	2390.000	AV	44.18	27.41	13.82	40.70	3.34	2.28	50.33	53.90	3.6	*1)
Vert.	4824.000	AV	36.39	31.17	6.01	36.53	3.34	2.28	42.66	53.90	11.2	
Vert.	7436.000	AV	35.26	37.10	7.63	36.73	3.34	2.28	48.88	53.90	5.0	
Vert.	14472.000	AV	37.18	41.47	10.36	34.63	3.34	-9.54	48.18	53.90	5.7	

Result = Reading + Ant.Fac. + Loss (Cable+(Attenuator or Filter)(below 18 GHz)) - Gain(Amplifier) + Duty factor + Distance factor

Distance factor : 1 GHz - 13 GHz : 20log(3.90 m / 3.0 m) = 2.28 dB

13 GHz - 40 GHz : 20log(1.0 m / 3.0 m) = -9.54 dB

Duty factor refer to "Duty factor Calculation chart" sheet.

*1) Not out of band emission (Leakage Power)

20 dBc Data Sheet (RBW 100 kHz, VBW 300 kHz)

Polarity	Frequency [MHz]	Detector	Reading [dBuV]	Ant.Fac. [dB/m]	Loss [dB]	Gain [dB]	Distance Factor [dB]	Result [dBuV/m]	Limit [dBuV/m]	Margin [dB]	Remark
Hori.	2412.000	PK	92.18	27.50	13.84	40.70	2.28	95.10	-	-	Carrier
Hori.	2400.000	PK	51.68	27.45	13.83	40.70	2.28	54.54	75.10	20.6	
Vert.	2412.000	PK	93.76	27.50	13.84	40.70	2.28	96.68	-	-	Carrier
Vert.	2400.000	PK	54.15	27.45	13.83	40.70	2.28	57.01	76.68	19.7	

Result = Reading + Ant.Fac. + Loss (Cable+(Attenuator or Filter)(below 18 GHz)) - Gain(Amplifier) + Distance factor

Distance factor : 1 GHz - 13 GHz : 20log(3.90 m / 3.0 m) = 2.28 dB

13 GHz - 40 GHz : 20log(1.0 m / 3.0 m) = -9.54 dB

UL Japan, Inc.

Shonan EMC Lab.

1-22-3 Megumigaoka, Hiratsuka-shi, Kanagawa-ken, 259-1220 JAPAN

Telephone : +81 463 50 6400

Facsimile : +81 463 50 6401

Radiated Spurious Emission
(Reference Plot for band-edge)

Test place : Shonan EMC Lab. No.3 Semi Anechoic Chamber
Report No. : 11334871S-A-R1
Date : August 30, 2016
Temperature / Humidity : 22 deg.C / 70 %RH
Engineer : Makoto Hosaka
Mode : Tx OFDM, VHT20, MIMO, 2412 MHz

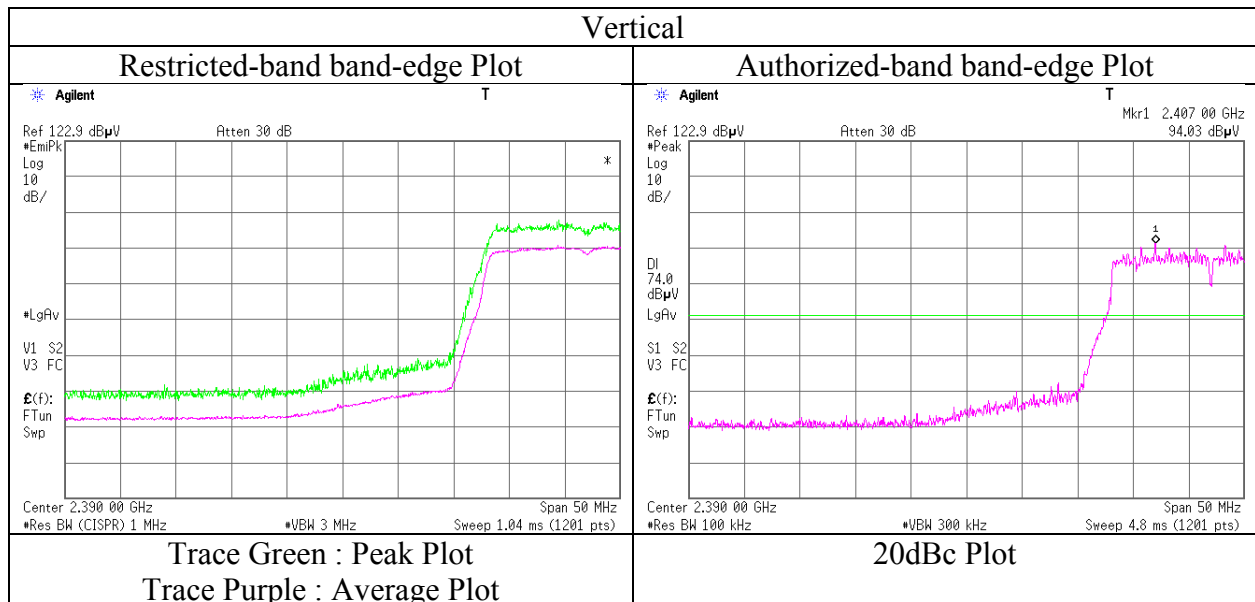
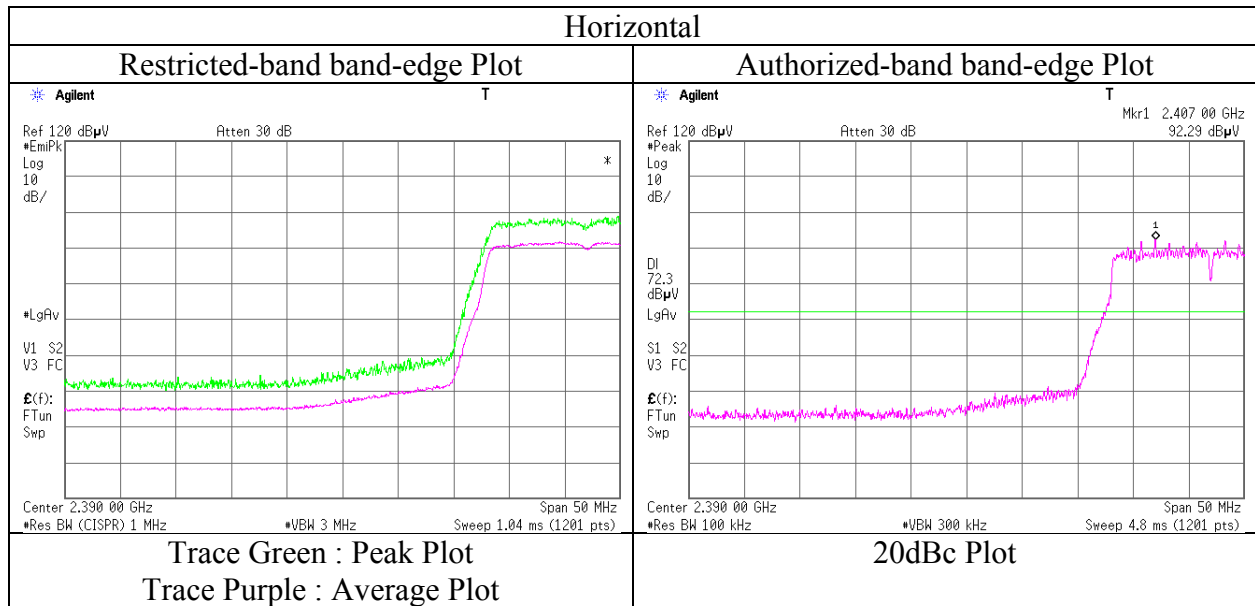

* Final result of restricted band edge was shown in tabular data.

Radiated Spurious Emission

Test place : Shonan EMC Lab. No.3 Semi Anechoic Chamber
Report No. : 11334871S-A-R1
Date : August 30, 2016 October 24, 2016 October 26, 2016 November 10, 2016
Temperature / Humidity : 22 deg.C / 70 %RH 25 deg.C / 58 %RH 25 deg.C / 49 %RH 23 deg.C / 35 %RH
Engineer : Makoto Hosaka Hikaru Shirasawa Hikaru Shirasawa Shinichi Takano
(1 GHz - 2.8 GHz) (2.8 GHz - 13 GHz) (13 GHz - 18 GHz) (30 MHz - 1 GHz),
(18 GHz - 26 GHz)

Mode : Tx OFDM, VHT20, MIMO, 2437 MHz

(* PK: Peak, AV: Average, QP: Quasi-Peak)

Polarity	Frequency [MHz]	Detector	Reading [dBuV]	Ant.Fac. [dB/m]	Loss [dB]	Gain [dB]	Distance Factor [dB]	Result [dBuV/m]	Limit [dBuV/m]	Margin [dB]	Height [cm]	Angle [deg]	Remark
Hori.	98.412	QP	47.30	9.70	7.54	32.14	0.00	32.40	43.50	11.1	299	35	
Hori.	125.003	QP	50.25	13.21	7.45	32.12	0.00	38.79	43.50	4.7	150	335	
Hori.	215.998	QP	48.46	11.72	8.22	32.03	0.00	36.37	43.50	7.1	158	278	
Hori.	412.162	QP	48.60	15.82	9.22	31.95	0.00	41.69	46.00	4.3	217	61	
Hori.	600.420	QP	41.38	18.97	10.00	31.91	0.00	38.44	46.00	7.5	126	103	
Hori.	625.094	QP	44.68	19.15	10.09	31.93	0.00	41.99	46.00	4.0	142	268	
Hori.	4874.000	PK	44.35	31.28	6.02	36.53	2.28	47.40	73.90	26.5	150	0	
Hori.	7311.000	PK	45.02	36.74	7.59	36.64	2.28	54.99	73.90	18.9	150	359	
Hori.	14622.000	PK	45.96	41.40	10.43	34.76	-9.54	53.49	73.90	20.4	150	0	
Vert.	36.158	QP	41.28	15.54	6.74	32.18	0.00	31.38	40.00	8.6	100	122	
Vert.	418.291	QP	48.26	15.94	9.25	31.95	0.00	41.50	46.00	4.5	124	163	
Vert.	600.301	QP	39.28	18.97	10.00	31.91	0.00	36.34	46.00	9.6	100	179	
Vert.	625.112	QP	42.64	19.15	10.09	31.93	0.00	39.95	46.00	6.0	100	182	
Vert.	4874.000	PK	45.26	31.28	6.02	36.53	2.28	48.31	73.90	25.5	151	247	
Vert.	7311.000	PK	45.72	36.74	7.59	36.64	2.28	55.69	73.90	18.2	150	359	
Vert.	14622.000	PK	46.34	41.40	10.43	34.76	-9.54	53.87	73.90	20.0	150	0	

Result = Reading + Ant.Fac. + Loss (Cable+(Attenuator or Filter)(below 18 GHz)) - Gain(Amplifier) + Distance factor

Distance factor : 1 GHz - 13 GHz : $20\log(3.90\text{ m} / 3.0\text{ m}) = 2.28\text{ dB}$

13 GHz - 40 GHz : $20\log(1.0\text{ m} / 3.0\text{ m}) = -9.54\text{ dB}$

Average measurement value with duty factor

Polarity	Frequency [MHz]	Detector	Reading [dBuV]	Ant.Fac. [dB/m]	Loss [dB]	Gain [dB]	Duty Factor [dB]	Distance Factor [dB]	Result [dBuV/m]	Limit [dBuV/m]	Margin [dB]	Remark
Hori.	4874.000	AV	34.91	31.28	6.02	36.53	3.34	2.28	41.30	53.90	12.6	
Hori.	7311.000	AV	35.30	36.74	7.59	36.64	3.34	2.28	48.61	53.90	5.3	
Hori.	14622.000	AV	36.34	41.40	10.43	34.76	3.34	-9.54	47.21	53.90	6.7	
Vert.	4874.000	AV	35.53	31.28	6.02	36.53	3.34	2.28	41.92	53.90	12.0	
Vert.	7311.000	AV	35.63	36.74	7.59	36.64	3.34	2.28	48.94	53.90	5.0	
Vert.	14622.000	AV	36.64	41.40	10.43	34.76	3.34	-9.54	47.51	53.90	6.4	

Result = Reading + Ant.Fac. + Loss (Cable+(Attenuator or Filter)(below 18 GHz)) - Gain(Amplifier) + Duty factor + Distance factor

Distance factor : 1 GHz - 13 GHz : $20\log(3.90\text{ m} / 3.0\text{ m}) = 2.28\text{ dB}$

13 GHz - 40 GHz : $20\log(1.0\text{ m} / 3.0\text{ m}) = -9.54\text{ dB}$

Duty factor refer to "Duty factor Calculation chart" sheet.

Radiated Spurious Emission

Test place : Shonan EMC Lab. No.3 Semi Anechoic Chamber
Report No. : 11334871S-A-R1
Date : August 30, 2016 October 25, 2016 October 26, 2016 November 10, 2016
Temperature / Humidity : 22 deg.C / 70 %RH 25 deg.C / 58 %RH 25 deg.C / 49 %RH 23 deg.C / 35 %RH
Engineer : Makoto Hosaka Hikaru Shirasawa Hikaru Shirasawa Shinichi Takano
 (1 GHz - 2.8 GHz) (2.8 GHz - 13 GHz) (13 GHz - 18 GHz) (18 GHz - 26 GHz)
Mode : Tx OFDM, VHT20, MIMO, 2462 MHz

(* PK: Peak, AV: Average, QP: Quasi-Peak)

Polarity	Frequency [MHz]	Detector	Reading [dBuV]	Ant.Fac. [dB/m]	Loss [dB]	Gain [dB]	Distance Factor [dB]	Result [dBuV/m]	Limit [dBuV/m]	Margin [dB]	Height [cm]	Angle [deg]	Remark
Hori.	2483.500	PK	49.71	27.79	13.91	40.69	2.28	53.00	73.90	20.9	144	47	
Hori.	4924.000	PK	44.47	31.38	6.04	36.52	2.28	47.65	73.90	26.2	150	359	
Hori.	7386.000	PK	44.63	36.95	7.60	36.69	2.28	54.77	73.90	19.1	150	0	
Hori.	14772.000	PK	45.49	41.33	10.53	34.88	-9.54	52.93	73.90	20.9	150	0	
Vert.	2483.500	PK	54.66	27.79	13.91	40.69	2.28	57.95	73.90	15.9	130	102	
Vert.	4924.000	PK	44.69	31.38	6.04	36.52	2.28	47.87	73.90	26.0	150	359	
Vert.	7386.000	PK	45.17	36.95	7.60	36.69	2.28	55.31	73.90	18.5	150	0	
Vert.	14772.000	PK	45.18	41.33	10.53	34.88	-9.54	52.62	73.90	21.2	150	0	

Result = Reading + Ant.Fac. + Loss (Cable+(Attenuator or Filter)(below 18 GHz)) - Gain(Amplifier) + Distance factor

Distance factor : 1 GHz - 13 GHz : 20log(3.90 m / 3.0 m) = 2.28 dB

13 GHz - 40 GHz : 20log(1.0 m / 3.0 m) = -9.54 dB

Average measurement value with duty factor

Polarity	Frequency [MHz]	Detector	Reading [dBuV]	Ant.Fac. [dB/m]	Loss [dB]	Gain [dB]	Duty Factor [dB]	Distance Factor [dB]	Result [dBuV/m]	Limit [dBuV/m]	Margin [dB]	Remark
Hori.	2483.500	AV	38.42	27.79	13.91	40.69	3.34	2.28	45.05	53.90	8.9	*1)
Hori.	4924.000	AV	35.31	31.38	6.04	36.52	3.34	2.28	41.83	53.90	12.1	
Hori.	7386.000	AV	35.35	36.95	7.60	36.69	3.34	2.28	48.83	53.90	5.1	
Hori.	14772.000	AV	36.02	41.33	10.53	34.88	3.34	-9.54	46.80	53.90	7.1	
Vert.	2483.500	AV	39.80	27.79	13.91	40.69	3.34	2.28	46.43	53.90	7.5	*1)
Vert.	4924.000	AV	35.32	31.38	6.04	36.52	3.34	2.28	41.84	53.90	12.1	
Vert.	7386.000	AV	35.30	36.95	7.60	36.69	3.34	2.28	48.78	53.90	5.1	
Vert.	14772.000	AV	35.90	41.33	10.53	34.88	3.34	-9.54	46.68	53.90	7.2	

Result = Reading + Ant.Fac. + Loss (Cable+(Attenuator or Filter)(below 18 GHz)) - Gain(Amplifier) + Duty factor + Distance factor

Distance factor : 1 GHz - 13 GHz : 20log(3.90 m / 3.0 m) = 2.28 dB

13 GHz - 40 GHz : 20log(1.0 m / 3.0 m) = -9.54 dB

Duty factor refer to "Duty factor Calculation chart" sheet.

*1) Not out of band emission (Leakage Power)

Radiated Spurious Emission
(Reference Plot for band-edge)

Test place : Shonan EMC Lab. No.3 Semi Anechoic Chamber
Report No. : 11334871S-A-R1
Date : August 30, 2016
Temperature / Humidity : 22 deg.C / 70 %RH
Engineer : Makoto Hosaka

Mode : Tx OFDM, VHT20, MIMO, 2462 MHz

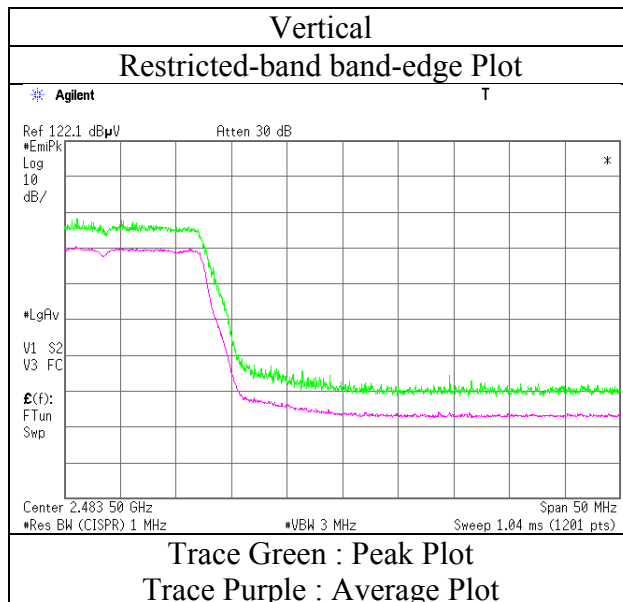
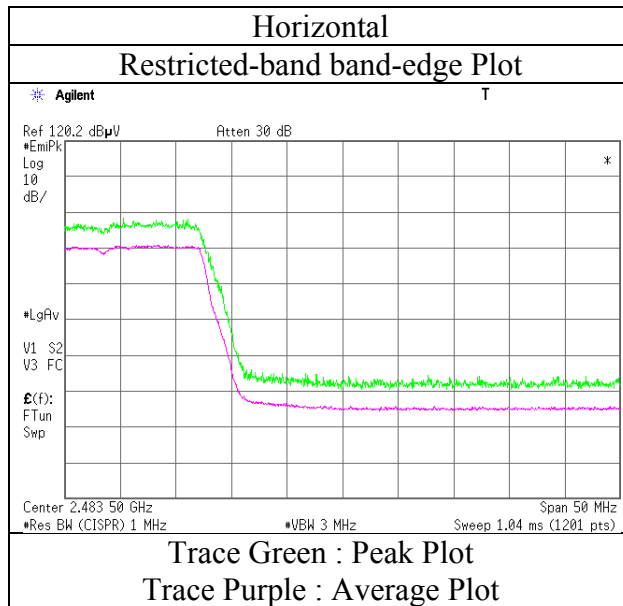

* Final result of restricted band edge was shown in tabular data.

Radiated Spurious Emission

Test place : Shonan EMC Lab. No.3 Semi Anechoic Chamber
Report No. : 11334871S-A-R1
Date : August 30, 2016 October 25, 2016 October 26, 2016 November 10, 2016
Temperature / Humidity : 22 deg.C / 70 %RH 25 deg.C / 58 %RH 25 deg.C / 49 %RH 23 deg.C / 35 %RH
Engineer : Makoto Hosaka Hikaru Shirasawa Hikaru Shirasawa Shinichi Takano
 (1 GHz - 2.8 GHz) (2.8 GHz - 13 GHz) (13 GHz - 18 GHz) (18 GHz - 26 GHz)
Mode : Tx OFDM, VHT20, MIMO, 2467 MHz

(* PK: Peak, AV: Average, QP: Quasi-Peak)

Polarity	Frequency [MHz]	Detector	Reading [dBuV]	Ant.Fac. [dB/m]	Loss [dB]	Gain [dB]	Distance Factor [dB]	Result [dBuV/m]	Limit [dBuV/m]	Margin [dB]	Height [cm]	Angle [deg]	Remark
Hori.	2312.800	PK	49.00	27.09	13.75	40.70	2.28	51.42	73.90	22.4	117	118	
Hori.	2483.500	PK	52.14	27.79	13.91	40.69	2.28	55.43	73.90	18.4	113	43	
Hori.	4934.000	PK	44.44	31.40	6.05	36.52	2.28	47.65	73.90	26.2	150	359	
Hori.	7401.000	PK	44.30	37.00	7.61	36.70	2.28	54.49	73.90	19.4	150	0	
Hori.	14802.000	PK	45.33	41.31	10.56	34.90	-9.54	52.76	73.90	21.1	150	0	
Vert.	2312.800	PK	48.57	27.09	13.75	40.70	2.28	50.99	73.90	22.9	129	92	
Vert.	2483.500	PK	50.59	27.79	13.91	40.69	2.28	53.88	73.90	20.0	131	96	
Vert.	4934.000	PK	44.97	31.40	6.05	36.52	2.28	48.18	73.90	25.7	150	0	
Vert.	7401.000	PK	45.18	37.00	7.61	36.70	2.28	55.37	73.90	18.5	150	359	
Vert.	14802.000	PK	45.49	41.31	10.56	34.90	-9.54	52.92	73.90	20.9	150	0	

Result = Reading + Ant.Fac. + Loss (Cable+(Attenuator or Filter)(below 18 GHz)) - Gain(Amplifier) + Distance factor

Distance factor : 1 GHz - 13 GHz : 20log(3.90 m / 3.0 m) = 2.28 dB

13 GHz - 40 GHz : 20log(1.0 m / 3.0 m) = -9.54 dB

Average measurement value with duty factor

Polarity	Frequency [MHz]	Detector	Reading [dBuV]	Ant.Fac. [dB/m]	Loss [dB]	Gain [dB]	Duty Factor [dB]	Distance Factor [dB]	Result [dBuV/m]	Limit [dBuV/m]	Margin [dB]	Remark
Hori.	2312.800	AV	40.02	27.09	13.75	40.70	3.34	2.28	45.78	53.90	8.1	118
Hori.	2483.500	AV	37.81	27.79	13.91	40.69	3.34	2.28	44.44	53.90	9.5	43
Hori.	4934.000	AV	34.90	31.40	6.05	36.52	3.34	2.28	41.45	53.90	12.5	359
Hori.	7401.000	AV	35.72	37.00	7.61	36.70	3.34	2.28	49.25	53.90	4.7	0
Hori.	14802.000	AV	35.73	41.31	10.56	34.90	3.34	-9.54	46.50	53.90	7.4	0
Vert.	2312.800	AV	40.13	27.09	13.75	40.70	3.34	2.28	45.89	53.90	8.0	92
Vert.	2483.500	AV	37.83	27.79	13.91	40.69	3.34	2.28	44.46	53.90	9.4	96
Vert.	4934.000	AV	35.18	31.40	6.05	36.52	3.34	2.28	41.73	53.90	12.2	0
Vert.	7401.000	AV	35.21	37.00	7.61	36.70	3.34	2.28	48.74	53.90	5.2	359
Vert.	14802.000	AV	35.84	41.31	10.56	34.90	3.34	-9.54	46.61	53.90	7.3	0

Result = Reading + Ant.Fac. + Loss (Cable+(Attenuator or Filter)(below 18 GHz)) - Gain(Amplifier) + Duty factor + Distance factor

Distance factor : 1 GHz - 13 GHz : 20log(3.90 m / 3.0 m) = 2.28 dB

13 GHz - 40 GHz : 20log(1.0 m / 3.0 m) = -9.54 dB

Duty factor refer to "Duty factor Calculation chart" sheet.

*1) Not out of band emission (Leakage Power)

Radiated Spurious Emission
(Reference Plot for band-edge)

Test place	Shonan EMC Lab. No.3 Semi Anechoic Chamber
Report No.	11334871S-A-R1
Date	August 30, 2016
Temperature / Humidity	22 deg.C / 70 %RH
Engineer	Makoto Hosaka
Mode	Tx OFDM, VHT20, MIMO, 2467 MHz

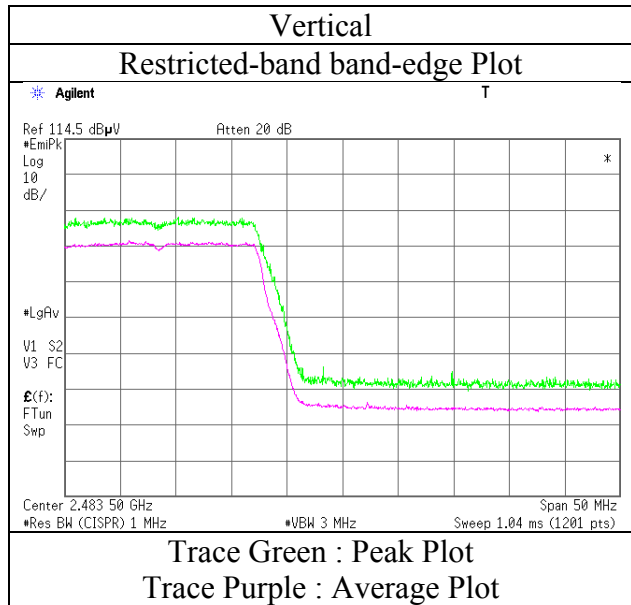
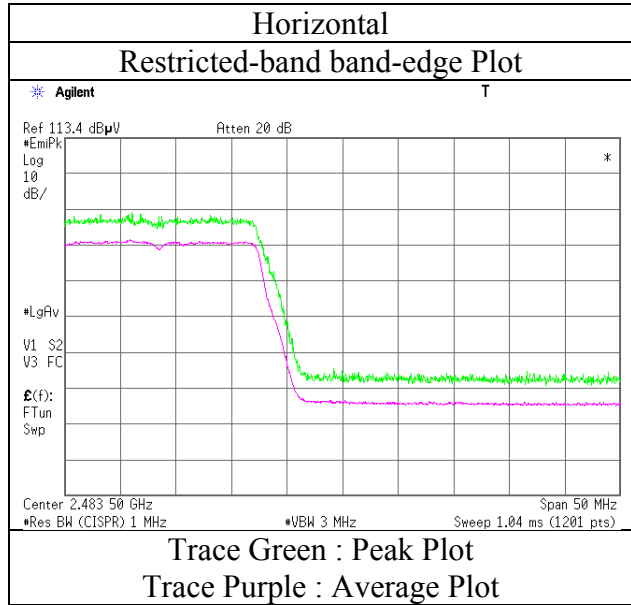

* Final result of restricted band edge was shown in tabular data.

Radiated Spurious Emission

Test place : Shonan EMC Lab. No.3 Semi Anechoic Chamber
Report No. : 11334871S-A-R1
Date : August 30, 2016 October 25, 2016 October 26, 2016 November 10, 2016
Temperature / Humidity : 22 deg.C / 70 %RH 25 deg.C / 58 %RH 25 deg.C / 49 %RH 23 deg.C / 35 %RH
Engineer : Makoto Hosaka Hikaru Shirasawa Hikaru Shirasawa Shinichi Takano
 (1 GHz - 2.8 GHz) (2.8 GHz - 13 GHz) (13 GHz - 18 GHz) (18 GHz - 26 GHz)
Mode : Tx OFDM, VHT20, MIMO, 2472 MHz

(* PK: Peak, AV: Average, QP: Quasi-Peak)

Polarity	Frequency [MHz]	Detector	Reading [dBuV]	Ant.Fac. [dB/m]	Loss [dB]	Gain [dB]	Distance Factor [dB]	Result [dBuV/m]	Limit [dBuV/m]	Margin [dB]	Height [cm]	Angle [deg]	Remark
Hori.	2483.500	PK	46.92	27.79	13.91	40.69	2.28	50.21	73.90	23.6	115	44	
Hori.	4944.000	PK	45.26	31.42	6.05	36.52	2.28	48.49	73.90	25.4	150	0	
Hori.	7416.000	PK	44.63	37.04	7.61	36.71	2.28	54.85	73.90	19.0	150	359	
Hori.	14832.000	PK	45.68	41.30	10.58	34.93	-9.54	53.09	73.90	20.8	150	0	
Vert.	2483.500	PK	47.03	27.79	13.91	40.69	2.28	50.32	73.90	23.5	114	89	
Vert.	4944.000	PK	44.55	31.42	6.05	36.52	2.28	47.78	73.90	26.1	150	359	
Vert.	7416.000	PK	45.14	37.04	7.61	36.71	2.28	55.36	73.90	18.5	150	0	
Vert.	14832.000	PK	45.83	41.30	10.58	34.93	-9.54	53.24	73.90	20.6	150	0	

Result = Reading + Ant.Fac. + Loss (Cable+(Attenuator or Filter)(below 18 GHz)) - Gain(Amplifier) + Distance factor

Distance factor : 1 GHz - 13 GHz : $20\log(3.90\text{ m} / 3.0\text{ m}) = 2.28\text{ dB}$

13 GHz - 40 GHz : $20\log(1.0\text{ m} / 3.0\text{ m}) = -9.54\text{ dB}$

Average measurement value with duty factor

Polarity	Frequency [MHz]	Detector	Reading [dBuV]	Ant.Fac. [dB/m]	Loss [dB]	Gain [dB]	Duty Factor [dB]	Distance Factor [dB]	Result [dBuV/m]	Limit [dBuV/m]	Margin [dB]	Remark
Hori.	2483.500	AV	37.57	27.79	13.91	40.69	3.34	2.28	44.20	53.90	9.7	*1)
Hori.	4944.000	AV	35.12	31.42	6.05	36.52	3.34	2.28	41.69	53.90	12.2	
Hori.	7416.000	AV	35.23	37.04	7.61	36.71	3.34	2.28	48.79	53.90	5.1	
Hori.	14832.000	AV	35.94	41.30	10.58	34.93	3.34	-9.54	46.69	53.90	7.2	
Vert.	2483.500	AV	37.45	27.79	13.91	40.69	3.34	2.28	44.08	53.90	9.8	*1)
Vert.	4944.000	AV	35.01	31.42	6.05	36.52	3.34	2.28	41.58	53.90	12.3	
Vert.	7416.000	AV	35.32	37.04	7.61	36.71	3.34	2.28	48.88	53.90	5.0	
Vert.	14832.000	AV	36.11	41.30	10.58	34.93	3.34	-9.54	46.86	53.90	7.0	

Result = Reading + Ant.Fac. + Loss (Cable+(Attenuator or Filter)(below 18 GHz)) - Gain(Amplifier) + Duty factor + Distance factor

Distance factor : 1 GHz - 13 GHz : $20\log(3.90\text{ m} / 3.0\text{ m}) = 2.28\text{ dB}$

13 GHz - 40 GHz : $20\log(1.0\text{ m} / 3.0\text{ m}) = -9.54\text{ dB}$

Duty factor refer to "Duty factor Calculation chart" sheet.

*1) Not out of band emission (Leakage Power)

Radiated Spurious Emission
(Reference Plot for band-edge)

Test place	Shonan EMC Lab. No.3 Semi Anechoic Chamber
Report No.	11334871S-A-R1
Date	August 30, 2016
Temperature / Humidity	22 deg.C / 70 %RH
Engineer	Makoto Hosaka
Mode	Tx OFDM, VHT20, MIMO, 2472 MHz

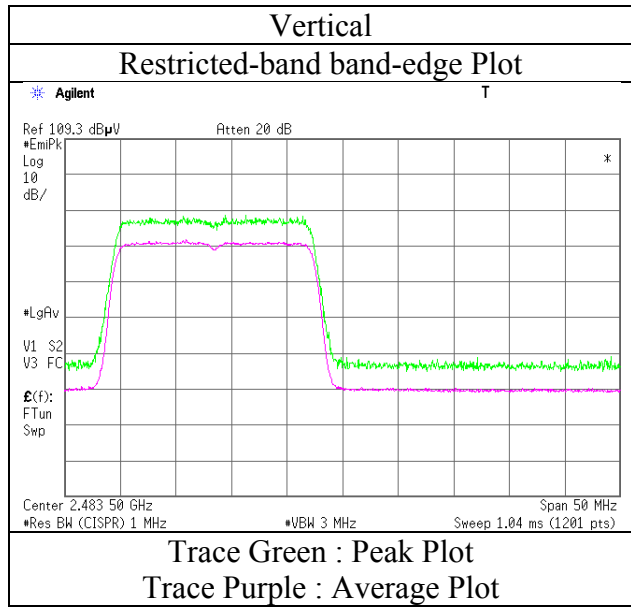
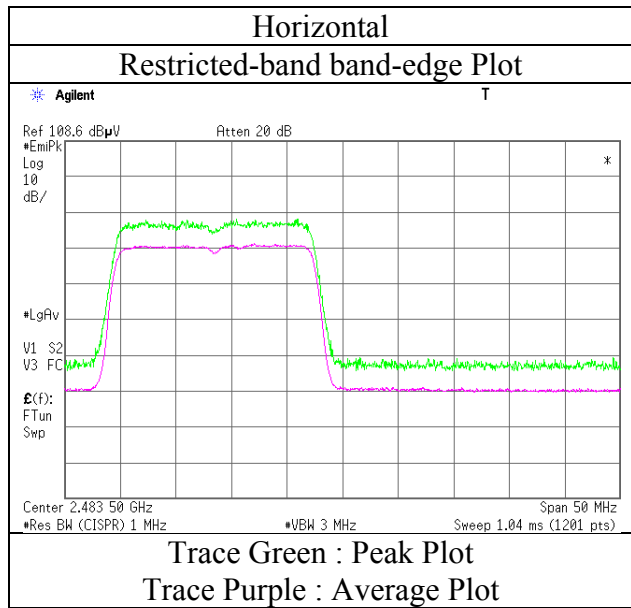

* Final result of restricted band edge was shown in tabular data.

Radiated Spurious Emission

Test place : Shonan EMC Lab. No.3 Semi Anechoic Chamber
Report No. : 11334871S-A-R1
Date : August 29, 2016
Temperature / Humidity : 23 deg.C / 61 %RH
Engineer : Makoto Hosaka
(1 GHz - 2.8 GHz)
Mode : Tx 11n-20, SISO, 2412 MHz

(* PK: Peak, AV: Average, QP: Quasi-Peak)

Polarity	Frequency [MHz]	Detector	Reading [dBuV]	Ant.Fac. [dB/m]	Loss [dB]	Gain [dB]	Distance Factor [dB]	Result [dBuV/m]	Limit [dBuV/m]	Margin [dB]	Height [cm]	Angle [deg]	Remark
Hori.	2390.000	PK	50.30	27.75	13.82	40.70	2.28	53.45	73.90	20.4	144	273	
Vert.	2390.000	PK	52.20	27.75	13.82	40.70	2.28	55.35	73.90	18.5	134	206	

Result = Reading + Ant.Fac. + Loss (Cable+(Attenuator or Filter)(below 18 GHz)) - Gain(Amplifier) + Distance factor

Distance factor : 1 GHz - 13 GHz : $20\log(3.90\text{ m} / 3.0\text{ m}) = 2.28\text{ dB}$

13 GHz - 40 GHz : $20\log(1.0\text{ m} / 3.0\text{ m}) = -9.54\text{ dB}$

Average measurement value with duty factor

Polarity	Frequency [MHz]	Detector	Reading [dBuV]	Ant.Fac. [dB/m]	Loss [dB]	Gain [dB]	Duty Factor [dB]	Distance Factor [dB]	Result [dBuV/m]	Limit [dBuV/m]	Margin [dB]	Remark
Hori.	2390.000	AV	37.91	27.75	13.82	40.70	2.06	2.28	43.12	53.90	10.8	*1)
Vert.	2390.000	AV	38.36	27.75	13.82	40.70	2.06	2.28	43.57	53.90	10.3	*1)

Result = Reading + Ant.Fac. + Loss (Cable+(Attenuator or Filter)(below 18 GHz)) - Gain(Amplifier) + Duty factor + Distance factor

Distance factor : 1 GHz - 13 GHz : $20\log(3.90\text{ m} / 3.0\text{ m}) = 2.28\text{ dB}$

13 GHz - 40 GHz : $20\log(1.0\text{ m} / 3.0\text{ m}) = -9.54\text{ dB}$

Duty factor refer to "Duty factor Calculation chart" sheet.

*1) Not out of band emission (Leakage Power)

20 dBc Data Sheet (RBW 100 kHz, VBW 300 kHz)

Polarity	Frequency [MHz]	Detector	Reading [dBuV]	Ant.Fac. [dB/m]	Loss [dB]	Gain [dB]	Distance Factor [dB]	Result [dBuV/m]	Limit [dBuV/m]	Margin [dB]	Remark
Hori.	2412.000	PK	83.92	27.79	13.84	40.70	2.28	87.13	-	-	
Hori.	2400.000	PK	42.74	27.76	13.83	40.70	2.28	45.91	67.13	21.2	
Vert.	2412.000	PK	85.69	27.79	13.84	40.70	2.28	88.90	-	-	
Vert.	2400.000	PK	42.97	27.76	13.83	40.70	2.28	46.14	68.90	22.8	

Result = Reading + Ant.Fac. + Loss (Cable+(Attenuator or Filter)(below 18 GHz)) - Gain(Amplifier) + Distance factor

Distance factor : 1 GHz - 13 GHz : $20\log(3.90\text{ m} / 3.0\text{ m}) = 2.28\text{ dB}$

13 GHz - 40 GHz : $20\log(1.0\text{ m} / 3.0\text{ m}) = -9.54\text{ dB}$

Radiated Spurious Emission
(Reference Plot for band-edge)

Test place : Shonan EMC Lab. No.3 Semi Anechoic Chamber
Report No. : 11334871S-A-R1
Date : August 29, 2016
Temperature / Humidity : 23 deg.C / 61 %RH
Engineer : Makoto Hosaka

Mode : Tx 11n-20, SISO, 2412 MHz

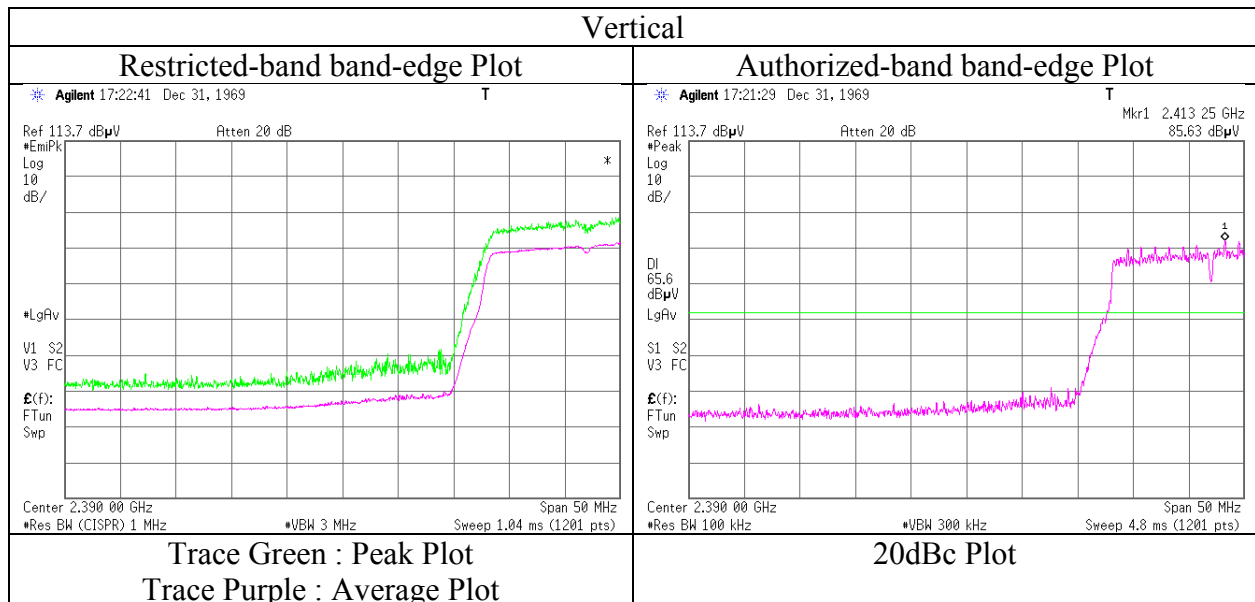
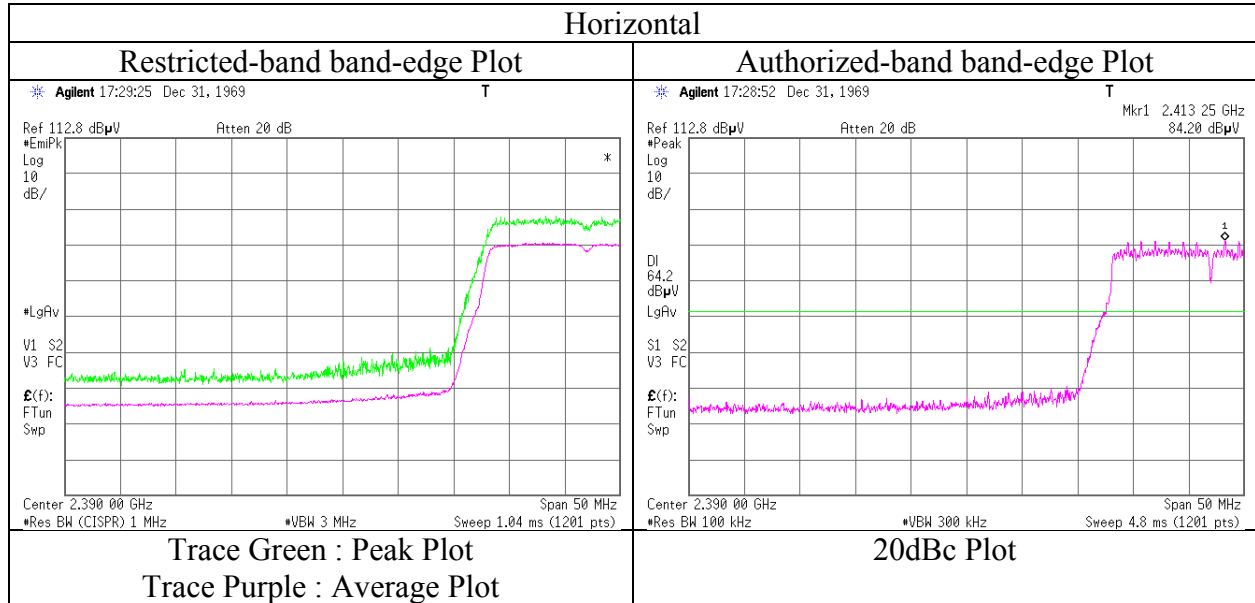

* Final result of restricted band edge was shown in tabular data.

Radiated Spurious Emission

Test place : Shonan EMC Lab. No.3 Semi Anechoic Chamber
Report No. : 11334871S-A-R1
Date : August 29, 2016
Temperature / Humidity : 23 deg.C / 61 %RH
Engineer : Makoto Hosaka

Mode : Tx 11n-20, SISO, 2462 MHz

(* PK: Peak, AV: Average, QP: Quasi-Peak)

Polarity	Frequency [MHz]	Detector	Reading [dBuV]	Ant.Fac. [dB/m]	Loss [dB]	Gain [dB]	Distance Factor [dB]	Result [dBuV/m]	Limit [dBuV/m]	Margin [dB]	Height [cm]	Angle [deg]	Remark
Hori.	2483.500	PK	55.66	27.91	13.91	40.69	2.28	59.07	73.90	14.8	131	318	
Vert.	2483.500	PK	57.23	27.91	13.91	40.69	2.28	60.64	73.90	13.2	125	215	

Result = Reading + Ant.Fac. + Loss (Cable+(Attenuator or Filter)(below 18 GHz)) - Gain(Amplifier) + Distance factor

Distance factor : 1 GHz - 13 GHz : $20\log(3.90\text{ m} / 3.0\text{ m}) = 2.28\text{ dB}$

13 GHz - 40 GHz : $20\log(1.0\text{ m} / 3.0\text{ m}) = -9.54\text{ dB}$

Average measurement value with duty factor

Polarity	Frequency [MHz]	Detector	Reading [dBuV]	Ant.Fac. [dB/m]	Loss [dB]	Gain [dB]	Duty Factor [dB]	Distance Factor [dB]	Result [dBuV/m]	Limit [dBuV/m]	Margin [dB]	Remark
Hori.	2483.500	AV	40.14	27.91	13.91	40.69	2.06	2.28	45.61	53.90	8.3	*1)
Vert.	2483.500	AV	41.90	27.91	13.91	40.69	2.06	2.28	47.37	53.90	6.5	*1)

Result = Reading + Ant.Fac. + Loss (Cable+(Attenuator or Filter)(below 18 GHz)) - Gain(Amplifier) + Duty factor + Distance factor

Distance factor : 1 GHz - 13 GHz : $20\log(3.90\text{ m} / 3.0\text{ m}) = 2.28\text{ dB}$

13 GHz - 40 GHz : $20\log(1.0\text{ m} / 3.0\text{ m}) = -9.54\text{ dB}$

Duty factor refer to "Duty factor Calculation chart" sheet.

*1) Not out of band emission (Leakage Power)

Radiated Spurious Emission
(Reference Plot for band-edge)

Test place	Shonan EMC Lab. No.3 Semi Anechoic Chamber
Report No.	11334871S-A-R1
Date	August 29, 2016
Temperature / Humidity	23 deg.C / 61 %RH
Engineer	Makoto Hosaka
Mode	Tx 11n-20, SISO, 2462 MHz

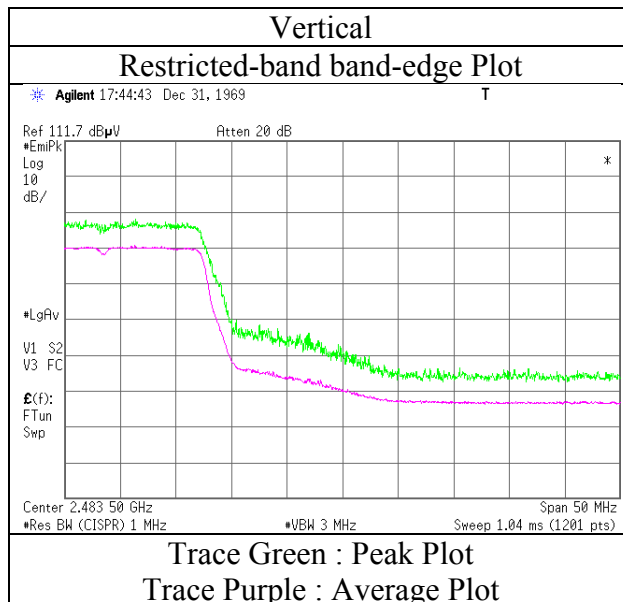
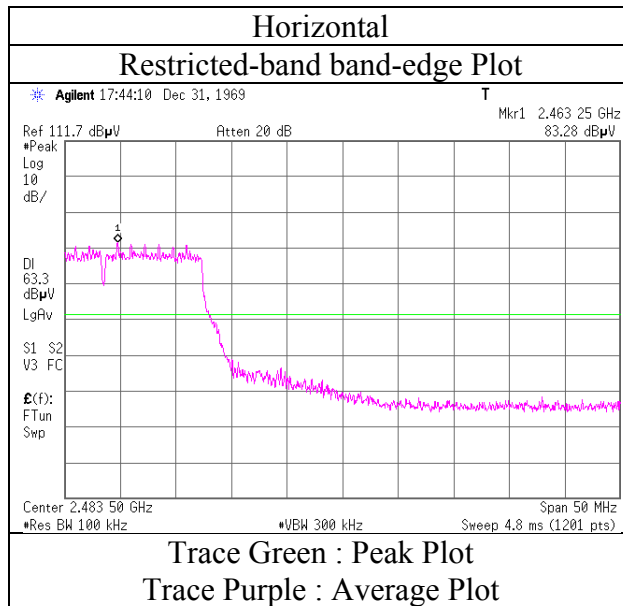

* Final result of restricted band edge was shown in tabular data.

Radiated Spurious Emission

Test place : Shonan EMC Lab. No.3 Semi Anechoic Chamber
Report No. : 11334871S-A-R1
Date : August 29, 2016
Temperature / Humidity : 23 deg.C / 61 %RH
Engineer : Makoto Hosaka

Mode : Tx 11n-20, SISO, 2467 MHz

(* PK: Peak, AV: Average, QP: Quasi-Peak)

Polarity	Frequency [MHz]	Detector	Reading [dBuV]	Ant.Fac. [dB/m]	Loss [dB]	Gain [dB]	Distance Factor [dB]	Result [dBuV/m]	Limit [dBuV/m]	Margin [dB]	Height [cm]	Angle [deg]	Remark
Hori.	2483.500	PK	46.77	27.91	13.91	40.69	2.28	50.18	73.90	23.7	131	310	
Vert.	2483.500	PK	46.40	27.91	13.91	40.69	2.28	49.81	73.90	24.0	125	211	

Result = Reading + Ant.Fac. + Loss (Cable+(Attenuator or Filter)(below 18 GHz)) - Gain(Amplifier) + Distance factor
Distance factor : 1 GHz - 13 GHz : $20\log(3.90\text{ m} / 3.0\text{ m}) = 2.28\text{ dB}$
13 GHz - 40 GHz : $20\log(1.0\text{ m} / 3.0\text{ m}) = -9.54\text{ dB}$

Average measurement value with duty factor

Polarity	Frequency [MHz]	Detector	Reading [dBuV]	Ant.Fac. [dB/m]	Loss [dB]	Gain [dB]	Duty Factor [dB]	Distance Factor [dB]	Result [dBuV/m]	Limit [dBuV/m]	Margin [dB]	Remark
Hori.	2483.500	AV	37.11	27.91	13.91	40.69	2.06	2.28	42.58	53.90	11.3	*1)
Vert.	2483.500	AV	37.33	27.91	13.91	40.69	2.06	2.28	42.80	53.90	11.1	*1)

Result = Reading + Ant.Fac. + Loss (Cable+(Attenuator or Filter)(below 18 GHz)) - Gain(Amplifier) + Duty factor + Distance factor
Distance factor : 1 GHz - 13 GHz : $20\log(3.90\text{ m} / 3.0\text{ m}) = 2.28\text{ dB}$
13 GHz - 40 GHz : $20\log(1.0\text{ m} / 3.0\text{ m}) = -9.54\text{ dB}$
Duty factor refer to "Duty factor Calculation chart" sheet.

Radiated Spurious Emission
(Reference Plot for band-edge)

Test place	Shonan EMC Lab. No.3 Semi Anechoic Chamber
Report No.	11334871S-A-R1
Date	August 29, 2016
Temperature / Humidity	23 deg.C / 61 %RH
Engineer	Makoto Hosaka
Mode	Tx 11n-20, SISO, 2467 MHz

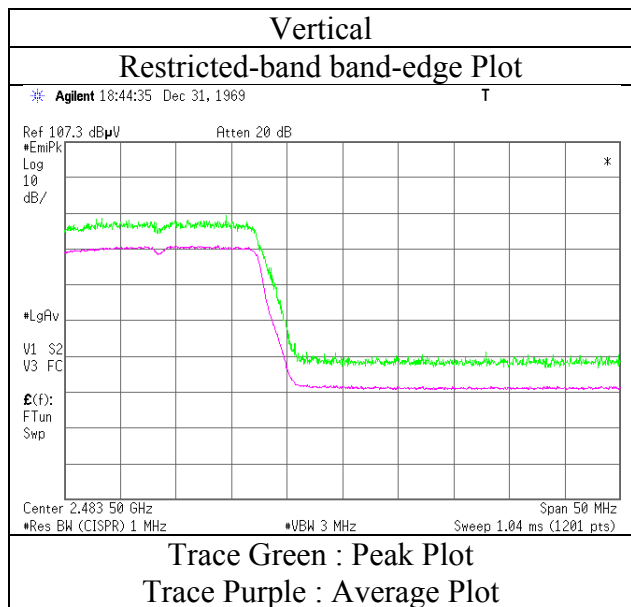
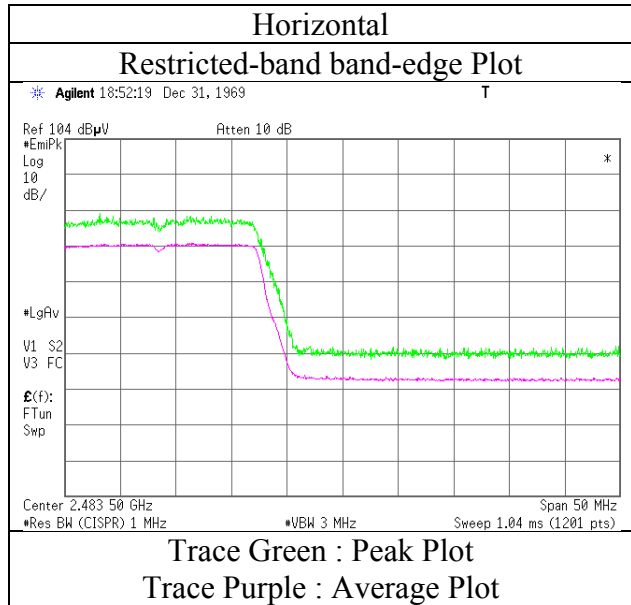

* Final result of restricted band edge was shown in tabular data.

Radiated Spurious Emission

Test place : Shonan EMC Lab. No.3 Semi Anechoic Chamber
Report No. : 11334871S-A-R1
Date : August 29, 2016
Temperature / Humidity : 23 deg.C / 61 %RH
Engineer : Makoto Hosaka

Mode : Tx 11n-20, SISO, 2472 MHz

(* PK: Peak, AV: Average, QP: Quasi-Peak)

Polarity	Frequency [MHz]	Detector	Reading [dBuV]	Ant.Fac. [dB/m]	Loss [dB]	Gain [dB]	Distance Factor [dB]	Result [dBuV/m]	Limit [dBuV/m]	Margin [dB]	Height [cm]	Angle [deg]	Remark
Hori.	2483.500	PK	46.33	27.91	13.91	40.69	2.28	49.74	73.90	24.1	110	319	
Vert.	2483.500	PK	46.44	27.91	13.91	40.69	2.28	49.85	73.90	24.0	110	208	

Result = Reading + Ant.Fac. + Loss (Cable+(Attenuator or Filter)(below 18 GHz)) - Gain(Amplifier) + Distance factor

Distance factor : 1 GHz - 13 GHz : $20\log(3.90\text{ m} / 3.0\text{ m}) = 2.28\text{ dB}$

13 GHz - 40 GHz : $20\log(1.0\text{ m} / 3.0\text{ m}) = -9.54\text{ dB}$

Average measurement value with duty factor

Polarity	Frequency [MHz]	Detector	Reading [dBuV]	Ant.Fac. [dB/m]	Loss [dB]	Gain [dB]	Duty Factor [dB]	Distance Factor [dB]	Result [dBuV/m]	Limit [dBuV/m]	Margin [dB]	Remark
Hori.	2483.500	AV	36.82	27.91	13.91	40.69	2.06	2.28	42.29	53.90	11.6	*1)
Vert.	2483.500	AV	37.10	27.91	13.91	40.69	2.06	2.28	42.57	53.90	11.3	*1)

Result = Reading + Ant.Fac. + Loss (Cable+(Attenuator or Filter)(below 18 GHz)) - Gain(Amplifier) + Duty factor + Distance factor

Distance factor : 1 GHz - 13 GHz : $20\log(3.90\text{ m} / 3.0\text{ m}) = 2.28\text{ dB}$

13 GHz - 40 GHz : $20\log(1.0\text{ m} / 3.0\text{ m}) = -9.54\text{ dB}$

Duty factor refer to "Duty factor Calculation chart" sheet.

*1) Not out of band emission (Leakage Power)

Radiated Spurious Emission
(Reference Plot for band-edge)

Test place	Shonan EMC Lab. No.3 Semi Anechoic Chamber
Report No.	11334871S-A-R1
Date	August 29, 2016
Temperature / Humidity	23 deg.C / 61 %RH
Engineer	Makoto Hosaka
Mode	Tx 11n-20, SISO, 2472 MHz

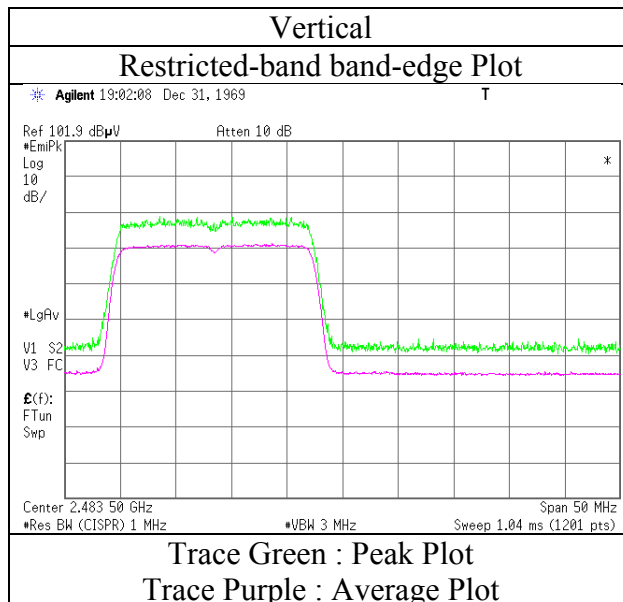
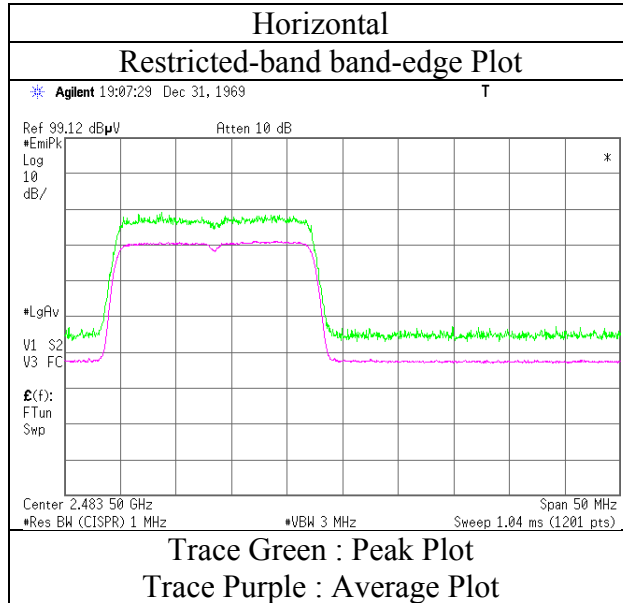

* Final result of restricted band edge was shown in tabular data.

Radiated Spurious Emission

Test place : Shonan EMC Lab. No.3 Semi Anechoic Chamber
Report No. : 11334871S-A-R1
Date : August 30, 2016 October 25, 2016 October 26, 2016 November 10, 2016
Temperature / Humidity : 23 deg.C / 61 %RH 23 deg.C / 35 %RH 25 deg.C / 49 %RH 23 deg.C / 35 %RH
Engineer : Makoto Hosaka Hikaru Shirasawa Hikaru Shirasawa Shinichi Takano
(1 GHz - 2.8 GHz) (2.8 GHz - 13 GHz) (13 GHz - 18 GHz) (18 GHz - 26 GHz)
Mode : Tx 11n-40, MIMO, 2422 MHz

(* PK: Peak, AV: Average, QP: Quasi-Peak)

Polarity	Frequency [MHz]	Detector	Reading [dBuV]	Ant.Fac. [dB/m]	Loss [dB]	Gain [dB]	Distance Factor [dB]	Result [dBuV/m]	Limit [dBuV/m]	Margin [dB]	Height [cm]	Angle [deg]	Remark
Hori.	2389.100	PK	55.41	27.41	13.82	40.70	2.28	58.22	73.90	15.6	110	35	
Hori.	2390.000	PK	53.37	27.41	13.82	40.70	2.28	56.18	73.90	17.7	110	35	
Hori.	4844.000	PK	44.39	31.21	6.02	36.53	2.28	47.37	73.90	26.5	150	0	
Hori.	7266.000	PK	45.91	36.61	7.57	36.61	2.28	55.76	73.90	18.1	150	359	
Hori.	14532.000	PK	46.46	41.44	10.38	34.69	-9.54	54.05	73.90	19.8	150	0	
Vert.	2389.100	PK	57.14	27.41	13.82	40.70	2.28	59.95	73.90	13.9	143	110	
Vert.	2390.000	PK	55.39	27.41	13.82	40.70	2.28	58.20	73.90	15.7	143	110	
Vert.	4844.000	PK	44.61	31.21	6.02	36.53	2.28	47.59	73.90	26.3	150	359	
Vert.	7266.000	PK	45.93	36.61	7.57	36.61	2.28	55.78	73.90	18.1	150	0	
Vert.	14532.000	PK	46.07	41.44	10.38	34.69	-9.54	53.66	73.90	20.2	150	0	

Result = Reading + Ant.Fac. + Loss (Cable+(Attenuator or Filter)(below 18 GHz)) - Gain(Amplifier) + Distance factor

Distance factor : 1 GHz - 13 GHz : 20log(3.90 m / 3.0 m) = 2.28 dB

13 GHz - 40 GHz : 20log(1.0 m / 3.0 m) = -9.54 dB

Average measurement value with duty factor

Polarity	Frequency [MHz]	Detector	Reading [dBuV]	Ant.Fac. [dB/m]	Loss [dB]	Gain [dB]	Duty Factor [dB]	Distance Factor [dB]	Result [dBuV/m]	Limit [dBuV/m]	Margin [dB]	Remark
Hori.	2389.100	AV	42.04	27.41	13.82	40.70	5.12	2.28	49.97	53.90	3.9	
Hori.	2390.000	AV	42.26	27.41	13.82	40.70	5.12	2.28	50.19	53.90	3.7	*1)
Hori.	4844.000	AV	35.35	31.21	6.02	36.53	5.12	2.28	43.45	53.90	10.5	
Hori.	7266.000	AV	35.84	36.61	7.57	36.61	5.12	2.28	50.81	53.90	3.1	
Hori.	14532.000	AV	36.63	41.44	10.38	34.69	5.12	-9.54	49.34	53.90	4.6	
Vert.	2389.100	AV	44.08	27.41	13.82	40.70	5.12	2.28	52.01	53.90	1.9	
Vert.	2390.000	AV	44.70	27.41	13.82	40.70	5.12	2.28	52.63	53.90	1.3	*1)
Vert.	4844.000	AV	35.64	31.21	6.02	36.53	5.12	2.28	43.74	53.90	10.2	
Vert.	7266.000	AV	35.89	36.61	7.57	36.61	5.12	2.28	50.86	53.90	3.0	
Vert.	14532.000	AV	36.70	41.44	10.38	34.69	5.12	-9.54	49.41	53.90	4.5	

Result = Reading + Ant.Fac. + Loss (Cable+(Attenuator or Filter)(below 18 GHz)) - Gain(Amplifier) + Duty factor + Distance factor

Distance factor : 1 GHz - 13 GHz : 20log(3.90 m / 3.0 m) = 2.28 dB

13 GHz - 40 GHz : 20log(1.0 m / 3.0 m) = -9.54 dB

Duty factor refer to "Duty factor Calculation chart" sheet.

*1) Not out of band emission (Leakage Power)

20 dBc Data Sheet (RBW 100 kHz, VBW 300 kHz)

Polarity	Frequency [MHz]	Detector	Reading [dBuV]	Ant.Fac. [dB/m]	Loss [dB]	Gain [dB]	Distance Factor [dB]	Result [dBuV/m]	Limit [dBuV/m]	Margin [dB]	Remark
Hori.	2422.000	PK	85.90	27.54	13.85	40.70	2.28	88.87	-	-	
Hori.	2400.000	PK	45.58	27.45	13.83	40.70	2.28	48.44	68.87	20.4	
Vert.	2422.000	PK	88.33	27.54	13.85	40.70	2.28	91.30	-	-	
Vert.	2400.000	PK	46.72	27.45	13.83	40.70	2.28	49.58	71.30	21.7	

Result = Reading + Ant.Fac. + Loss (Cable+(Attenuator or Filter)(below 18 GHz)) - Gain(Amplifier) + Distance factor

Distance factor : 1 GHz - 13 GHz : 20log(3.90 m / 3.0 m) = 2.28 dB

13 GHz - 40 GHz : 20log(1.0 m / 3.0 m) = -9.54 dB

Radiated Spurious Emission
(Reference Plot for band-edge)

Test place : Shonan EMC Lab. No.3 Semi Anechoic Chamber
Report No. : 11334871S-A-R1
Date : August 30, 2016
Temperature / Humidity : 23 deg.C / 61 %RH
Engineer : Makoto Hosaka
Mode : Tx 11n-40, MIMO, 2422 MHz

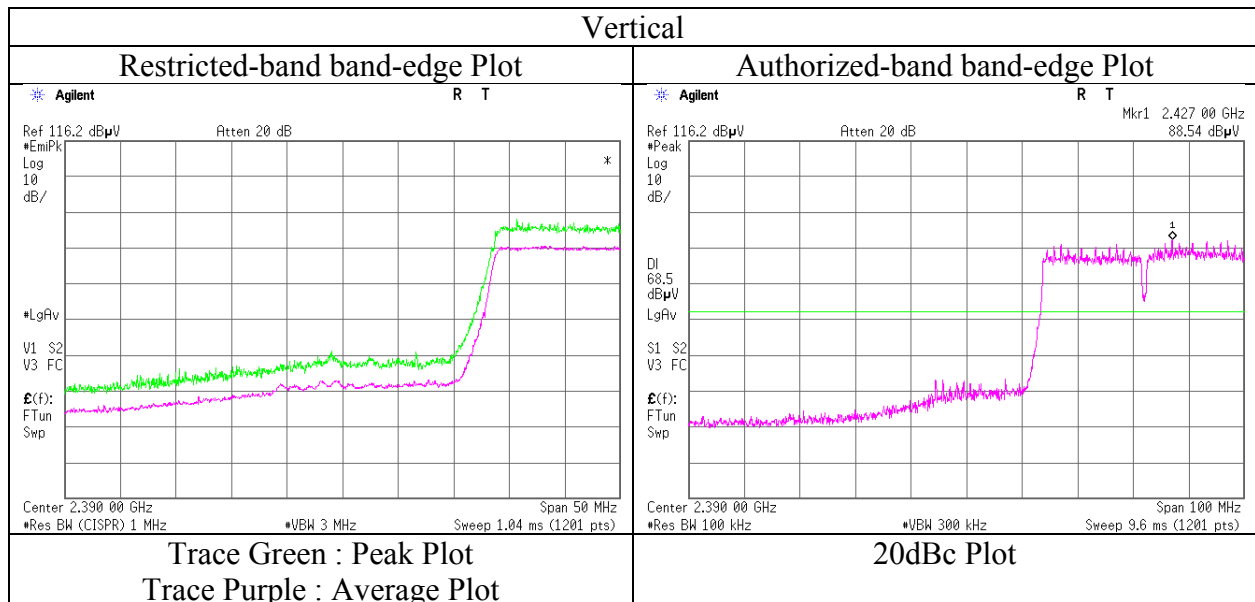
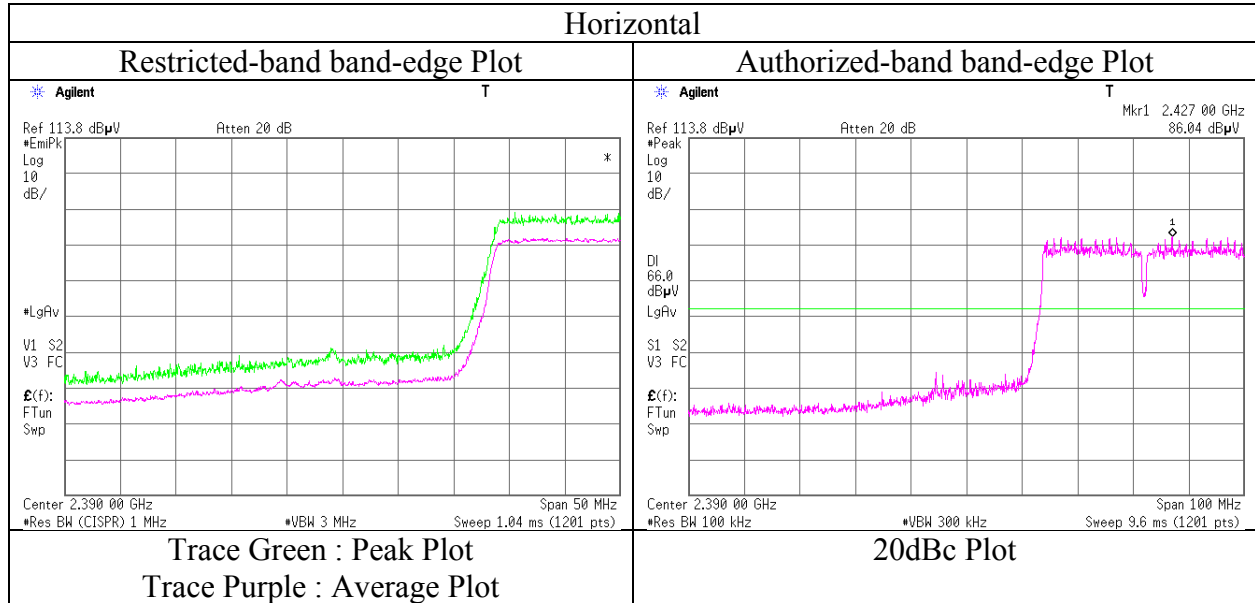

* Final result of restricted band edge was shown in tabular data.

Radiated Spurious Emission

Test place : Shonan EMC Lab. No.3 Semi Anechoic Chamber
Report No. : 11334871S-A-R1
Date : August 30, 2016 October 25, 2016 October 26, 2016 November 10, 2016
Temperature / Humidity : 23 deg.C / 61 %RH 23 deg.C / 35 %RH 25 deg.C / 49 %RH 23 deg.C / 35 %RH
Engineer : Makoto Hosaka Hikaru Shirasawa Hikaru Shirasawa Shinichi Takano
 (1 GHz - 2.8 GHz) (2.8 GHz - 13 GHz) (13 GHz - 18 GHz) (18 GHz - 26 GHz)
Mode : Tx 11n-40, MIMO, 2437 MHz

(* PK: Peak, AV: Average, QP: Quasi-Peak)

Polarity	Frequency [MHz]	Detector	Reading [dBuV]	Ant.Fac. [dB/m]	Loss [dB]	Gain [dB]	Distance Factor [dB]	Result [dBuV/m]	Limit [dBuV/m]	Margin [dB]	Height [cm]	Angle [deg]	Remark
Hori.	4874.000	PK	45.88	31.28	6.02	36.53	2.28	48.93	73.90	24.9	150	359	
Hori.	7311.000	PK	45.02	36.74	7.59	36.64	2.28	54.99	73.90	18.9	150	0	
Hori.	14622.000	PK	45.90	41.40	10.43	34.76	-9.54	53.43	73.90	20.4	150	0	
Vert.	4874.000	PK	44.32	31.28	6.02	36.53	2.28	47.37	73.90	26.5	150	0	
Vert.	7311.000	PK	44.81	36.74	7.59	36.64	2.28	54.78	73.90	19.1	150	359	
Vert.	14622.000	PK	46.01	41.40	10.43	34.76	-9.54	53.54	73.90	20.3	150	0	

Result = Reading + Ant.Fac. + Loss (Cable+(Attenuator or Filter)(below 18 GHz)) - Gain(Amplifier) + Distance factor

Distance factor : 1 GHz - 13 GHz : $20\log(3.90\text{ m} / 3.0\text{ m}) = 2.28\text{ dB}$

13 GHz - 40 GHz : $20\log(1.0\text{ m} / 3.0\text{ m}) = -9.54\text{ dB}$

Average measurement value with duty factor

Polarity	Frequency [MHz]	Detector	Reading [dBuV]	Ant.Fac. [dB/m]	Loss [dB]	Gain [dB]	Duty Factor [dB]	Distance Factor [dB]	Result [dBuV/m]	Limit [dBuV/m]	Margin [dB]	Remark
Hori.	4874.000	AV	34.86	31.28	6.02	36.53	5.12	2.28	43.03	53.90	10.9	
Hori.	7311.000	AV	35.53	36.74	7.59	36.64	5.12	2.28	50.62	53.90	3.3	
Hori.	14622.000	AV	36.33	41.40	10.43	34.76	5.12	-9.54	48.98	53.90	4.9	
Vert.	4874.000	AV	34.67	31.28	6.02	36.53	5.12	2.28	42.84	53.90	11.1	
Vert.	7311.000	AV	35.68	36.74	7.59	36.64	5.12	2.28	50.77	53.90	3.1	
Vert.	14622.000	AV	36.51	41.40	10.43	34.76	5.12	-9.54	49.16	53.90	4.7	

Result = Reading + Ant.Fac. + Loss (Cable+(Attenuator or Filter)(below 18 GHz)) - Gain(Amplifier) + Duty factor + Distance factor

Distance factor : 1 GHz - 13 GHz : $20\log(3.90\text{ m} / 3.0\text{ m}) = 2.28\text{ dB}$

13 GHz - 40 GHz : $20\log(1.0\text{ m} / 3.0\text{ m}) = -9.54\text{ dB}$

Duty factor refer to "Duty factor Calculation chart" sheet.

Radiated Spurious Emission

Test place : Shonan EMC Lab. No.3 Semi Anechoic Chamber
Report No. : 11334871S-A-R1
Date : August 30, 2016 October 25, 2016 October 26, 2016 November 10, 2016
Temperature / Humidity : 23 deg.C / 61 %RH 23 deg.C / 35 %RH 25 deg.C / 49 %RH 23 deg.C / 35 %RH
Engineer : Makoto Hosaka Hikaru Shirasawa Hikaru Shirasawa Shinichi Takano
(1 GHz - 2.8 GHz) (2.8 GHz - 13 GHz) (13 GHz - 18 GHz) (18 GHz - 26 GHz)
Mode : Tx 11n-40, MIMO, 2457 MHz

(* PK: Peak, AV: Average, QP: Quasi-Peak)

Polarity	Frequency [MHz]	Detector	Reading [dBuV]	Ant.Fac. [dB/m]	Loss [dB]	Gain [dB]	Distance Factor [dB]	Result [dBuV/m]	Limit [dBuV/m]	Margin [dB]	Height [cm]	Angle [deg]	Remark
Hori.	2483.500	PK	48.66	27.79	13.91	40.69	2.28	51.95	73.90	21.9	116	43	
Hori.	4914.000	PK	44.36	31.36	6.04	36.53	2.28	47.51	73.90	26.3	150	359	
Hori.	7371.000	PK	44.29	36.91	7.60	36.68	2.28	54.40	73.90	19.5	150	0	
Hori.	14742.000	PK	45.39	41.34	10.52	34.85	-9.54	52.86	73.90	21.0	150	0	
Vert.	2483.500	PK	48.40	27.79	13.91	40.69	2.28	51.69	73.90	22.2	137	111	
Vert.	4914.000	PK	45.14	31.36	6.04	36.53	2.28	48.29	73.90	25.6	150	0	
Vert.	7371.000	PK	45.40	36.91	7.60	36.68	2.28	55.51	73.90	18.3	150	359	
Vert.	14742.000	PK	45.99	41.34	10.52	34.85	-9.54	53.46	73.90	20.4	150	0	

Result = Reading + Ant.Fac. + Loss (Cable+(Attenuator or Filter)(below 18 GHz)) - Gain(Amplifier) + Distance factor

Distance factor : 1 GHz - 13 GHz : $20\log(3.90\text{ m} / 3.0\text{ m}) = 2.28\text{ dB}$

13 GHz - 40 GHz : $20\log(1.0\text{ m} / 3.0\text{ m}) = -9.54\text{ dB}$

Average measurement value with duty factor

Polarity	Frequency [MHz]	Detector	Reading [dBuV]	Ant.Fac. [dB/m]	Loss [dB]	Gain [dB]	Duty Factor [dB]	Distance Factor [dB]	Result [dBuV/m]	Limit [dBuV/m]	Margin [dB]	Remark
Hori.	2483.500	AV	38.78	27.79	13.91	40.69	5.12	2.28	47.19	53.90	6.7	*1)
Hori.	4914.000	AV	35.13	31.36	6.04	36.53	5.12	2.28	43.40	53.90	10.5	
Hori.	7371.000	AV	35.05	36.91	7.60	36.68	5.12	2.28	50.28	53.90	3.6	
Hori.	14742.000	AV	35.92	41.34	10.52	34.85	5.12	-9.54	48.51	53.90	5.4	
Vert.	2483.500	AV	38.55	27.79	13.91	40.69	5.12	2.28	46.96	53.90	6.9	*1)
Vert.	4914.000	AV	35.05	31.36	6.04	36.53	5.12	2.28	43.32	53.90	10.6	
Vert.	7371.000	AV	35.67	36.91	7.60	36.68	5.12	2.28	50.90	53.90	3.0	
Vert.	14742.000	AV	35.88	41.34	10.52	34.85	5.12	-9.54	48.47	53.90	5.4	

Result = Reading + Ant.Fac. + Loss (Cable+(Attenuator or Filter)(below 18 GHz)) - Gain(Amplifier) + Duty factor + Distance factor

Distance factor : 1 GHz - 13 GHz : $20\log(3.90\text{ m} / 3.0\text{ m}) = 2.28\text{ dB}$

13 GHz - 40 GHz : $20\log(1.0\text{ m} / 3.0\text{ m}) = -9.54\text{ dB}$

Duty factor refer to "Duty factor Calculation chart" sheet.

*1) Not out of band emission (Leakage Power)

Radiated Spurious Emission
(Reference Plot for band-edge)

Test place	Shonan EMC Lab. No.3 Semi Anechoic Chamber
Report No.	11334871S-A-R1
Date	August 30, 2016
Temperature / Humidity	23 deg.C / 61 %RH
Engineer	Makoto Hosaka
Mode	Tx 11n-40, MIMO, 2457 MHz

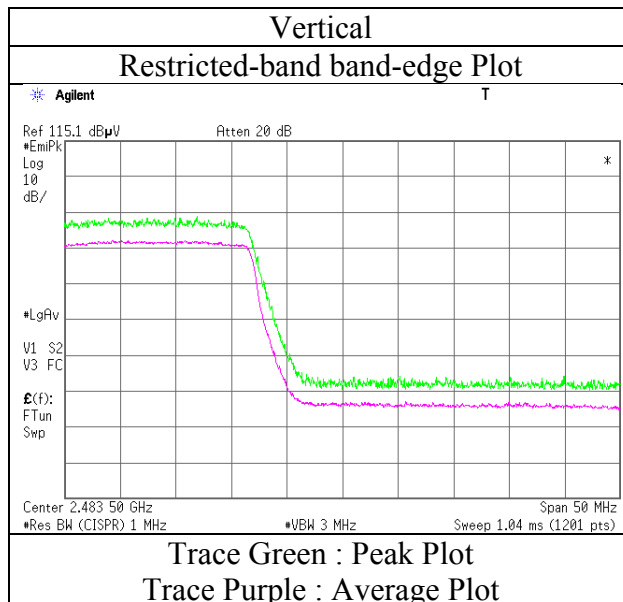
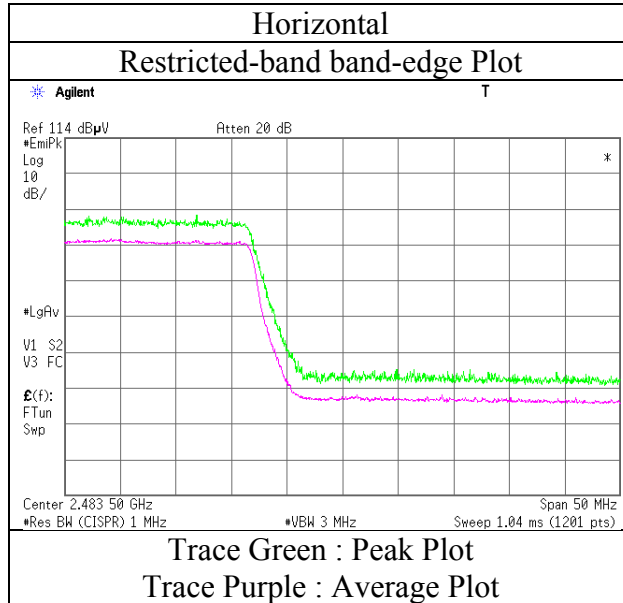

* Final result of restricted band edge was shown in tabular data.

Radiated Spurious Emission

Test place : Shonan EMC Lab. No.3 Semi Anechoic Chamber
Report No. : 11334871S-A-R1
Date : August 30, 2016 October 25, 2016 October 26, 2016 November 10, 2016
Temperature / Humidity : 23 deg.C / 61 %RH 23 deg.C / 35 %RH 25 deg.C / 49 %RH 23 deg.C / 35 %RH
Engineer : Makoto Hosaka Hikaru Shirasawa Hikaru Shirasawa Shinichi Takano
(1 GHz - 2.8 GHz) (2.8 GHz - 13 GHz) (13 GHz - 18 GHz) (18 GHz - 26 GHz)
Mode : Tx 11n-40, MIMO, 2462 MHz

(* PK: Peak, AV: Average, QP: Quasi-Peak)

Polarity	Frequency [MHz]	Detector	Reading [dBuV]	Ant.Fac. [dB/m]	Loss [dB]	Gain [dB]	Distance Factor [dB]	Result [dBuV/m]	Limit [dBuV/m]	Margin [dB]	Height [cm]	Angle [deg]	Remark
Hori.	2483.500	PK	54.44	27.79	13.91	40.69	2.28	57.73	73.90	16.1	116	46	
Hori.	4924.000	PK	45.01	31.38	6.04	36.52	2.28	48.19	73.90	25.7	150	0	
Hori.	7386.000	PK	44.92	36.95	7.60	36.69	2.28	55.06	73.90	18.8	150	359	
Hori.	14772.000	PK	46.32	41.33	10.53	34.88	-9.54	53.76	73.90	20.1	150	0	
Vert.	2483.500	PK	54.78	27.79	13.91	40.69	2.28	58.07	73.90	15.8	133	101	
Vert.	4924.000	PK	44.42	31.38	6.04	36.52	2.28	47.60	73.90	26.3	150	359	
Vert.	7386.000	PK	45.38	36.95	7.60	36.69	2.28	55.52	73.90	18.3	150	0	
Vert.	14772.000	PK	46.12	41.33	10.53	34.88	-9.54	53.56	73.90	20.3	150	0	

Result = Reading + Ant.Fac. + Loss (Cable+(Attenuator or Filter)(below 18 GHz)) - Gain(Amplifier) + Distance factor

Distance factor : 1 GHz - 13 GHz : $20\log(3.90\text{ m} / 3.0\text{ m}) = 2.28\text{ dB}$

13 GHz - 40 GHz : $20\log(1.0\text{ m} / 3.0\text{ m}) = -9.54\text{ dB}$

Average measurement value with duty factor

Polarity	Frequency [MHz]	Detector	Reading [dBuV]	Ant.Fac. [dB/m]	Loss [dB]	Gain [dB]	Duty Factor [dB]	Distance Factor [dB]	Result [dBuV/m]	Limit [dBuV/m]	Margin [dB]	Remark
Hori.	2483.500	AV	39.89	27.79	13.91	40.69	5.12	2.28	48.30	53.90	5.6	*1)
Hori.	4924.000	AV	34.86	31.38	6.04	36.52	5.12	2.28	43.16	53.90	10.7	
Hori.	7386.000	AV	35.18	36.95	7.60	36.69	5.12	2.28	50.44	53.90	3.5	
Hori.	14772.000	AV	36.24	41.33	10.53	34.88	5.12	-9.54	48.80	53.90	5.1	
Vert.	2483.500	AV	40.81	27.79	13.91	40.69	5.12	2.28	49.22	53.90	4.7	*1)
Vert.	4924.000	AV	34.98	31.38	6.04	36.52	5.12	2.28	43.28	53.90	10.6	
Vert.	7386.000	AV	35.51	36.95	7.60	36.69	5.12	2.28	50.77	53.90	3.1	
Vert.	14772.000	AV	36.01	41.33	10.53	34.88	5.12	-9.54	48.57	53.90	5.3	

Result = Reading + Ant.Fac. + Loss (Cable+(Attenuator or Filter)(below 18 GHz)) - Gain(Amplifier) + Duty factor + Distance factor

Distance factor : 1 GHz - 13 GHz : $20\log(3.90\text{ m} / 3.0\text{ m}) = 2.28\text{ dB}$

13 GHz - 40 GHz : $20\log(1.0\text{ m} / 3.0\text{ m}) = -9.54\text{ dB}$

Duty factor refer to "Duty factor Calculation chart" sheet.

*1) Not out of band emission (Leakage Power)

Radiated Spurious Emission
(Reference Plot for band-edge)

Test place	Shonan EMC Lab. No.3 Semi Anechoic Chamber
Report No.	11334871S-A-R1
Date	August 30, 2016
Temperature / Humidity	23 deg.C / 61 %RH
Engineer	Makoto Hosaka
Mode	Tx 11n-40, MIMO, 2462 MHz

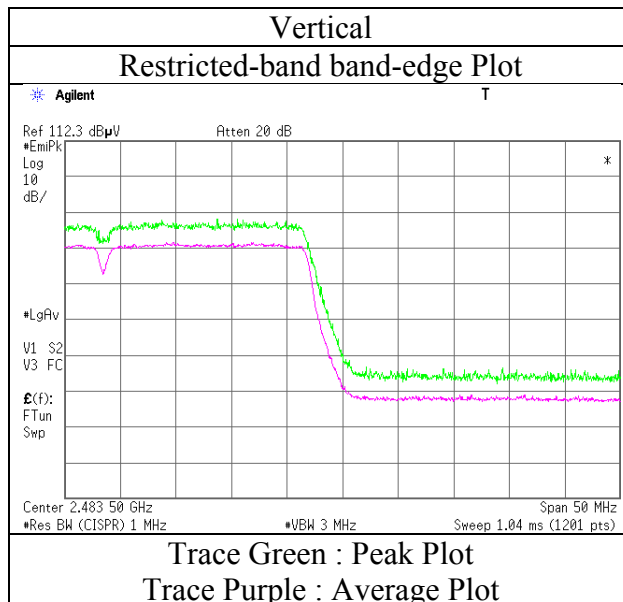
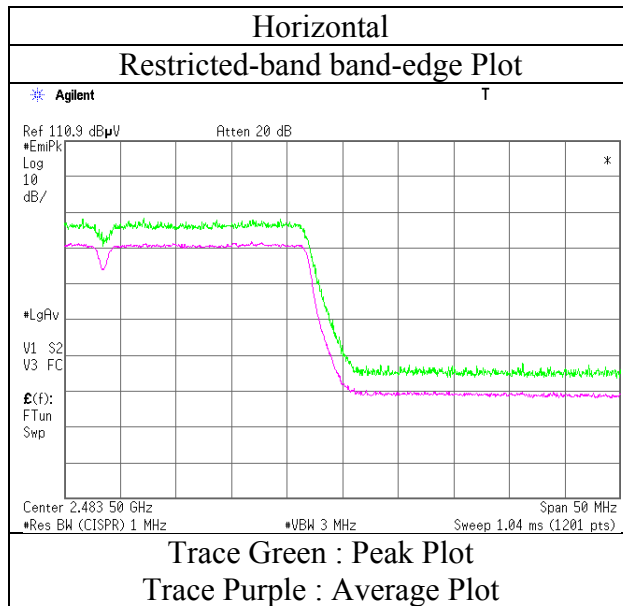

* Final result of restricted band edge was shown in tabular data.

Radiated Spurious Emission

Test place : Shonan EMC Lab. No.3 Semi Anechoic Chamber
Report No. : 11334871S-A-R1
Date : August 30, 2016
Temperature / Humidity : 23 deg.C / 61 %RH
Engineer : Makoto Hosaka

Mode : Tx 11n-40, SISO, 2422 MHz

(* PK: Peak, AV: Average, QP: Quasi-Peak)

Polarity	Frequency [MHz]	Detector	Reading [dBuV]	Ant.Fac. [dB/m]	Loss [dB]	Gain [dB]	Distance Factor [dB]	Result [dBuV/m]	Limit [dBuV/m]	Margin [dB]	Height [cm]	Angle [deg]	Remark
Hori.	2384.460	PK	51.58	27.39	13.82	40.70	2.28	54.37	73.90	19.5	134	45	
Hori.	2387.880	PK	54.33	27.40	13.82	40.70	2.28	57.13	73.90	16.7	134	45	
Hori.	2390.000	PK	53.75	27.41	13.82	40.70	2.28	56.56	73.90	17.3	134	45	
Vert.	2384.460	PK	55.68	27.39	13.82	40.70	2.28	58.47	73.90	15.4	137	98	
Vert.	2387.880	PK	57.78	27.40	13.82	40.70	2.28	60.58	73.90	13.3	137	98	
Vert.	2390.000	PK	55.54	27.41	13.82	40.70	2.28	58.35	73.90	15.5	137	98	

Result = Reading + Ant.Fac. + Loss (Cable+(Attenuator or Filter)(below 18 GHz)) - Gain(Amplifier) + Distance factor

Distance factor : 1 GHz - 13 GHz : $20\log(3.90\text{ m} / 3.0\text{ m}) = 2.28\text{ dB}$

13 GHz - 40 GHz : $20\log(1.0\text{ m} / 3.0\text{ m}) = -9.54\text{ dB}$

Average measurement value with duty factor

Polarity	Frequency [MHz]	Detector	Reading [dBuV]	Ant.Fac. [dB/m]	Loss [dB]	Gain [dB]	Duty Factor [dB]	Distance Factor [dB]	Result [dBuV/m]	Limit [dBuV/m]	Margin [dB]	Remark
Hori.	2384.460	AV	40.95	27.39	13.82	40.70	3.48	2.28	47.22	53.90	6.7	
Hori.	2387.880	AV	41.26	27.40	13.82	40.70	3.48	2.28	47.54	53.90	6.4	
Hori.	2390.000	AV	41.63	27.41	13.82	40.70	3.48	2.28	47.92	53.90	6.0	*1)
Vert.	2384.460	AV	44.38	27.39	13.82	40.70	3.48	2.28	50.65	53.90	3.3	
Vert.	2387.880	AV	44.34	27.40	13.82	40.70	3.48	2.28	50.62	53.90	3.3	
Vert.	2390.000	AV	45.18	27.41	13.82	40.70	3.48	2.28	51.47	53.90	2.4	*1)

Result = Reading + Ant.Fac. + Loss (Cable+(Attenuator or Filter)(below 18 GHz)) - Gain(Amplifier) + Duty factor + Distance factor

Distance factor : 1 GHz - 13 GHz : $20\log(3.90\text{ m} / 3.0\text{ m}) = 2.28\text{ dB}$

13 GHz - 40 GHz : $20\log(1.0\text{ m} / 3.0\text{ m}) = -9.54\text{ dB}$

Duty factor refer to "Duty factor Calculation chart" sheet.

*1) Not out of band emission (Leakage Power)

Radiated Spurious Emission
(Reference Plot for band-edge)

Test place : Shonan EMC Lab. No.3 Semi Anechoic Chamber
Report No. : 11334871S-A-R1
Date : August 30, 2016
Temperature / Humidity : 23 deg.C / 61 %RH
Engineer : Makoto Hosaka
Mode : Tx 11n-40, SISO, 2422 MHz

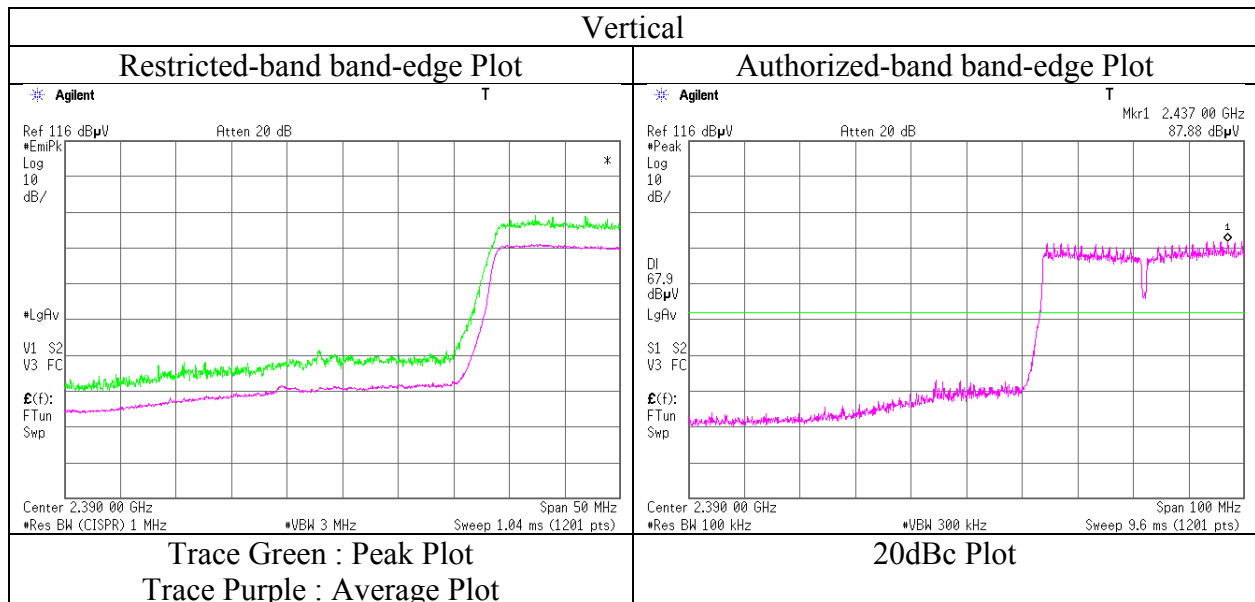
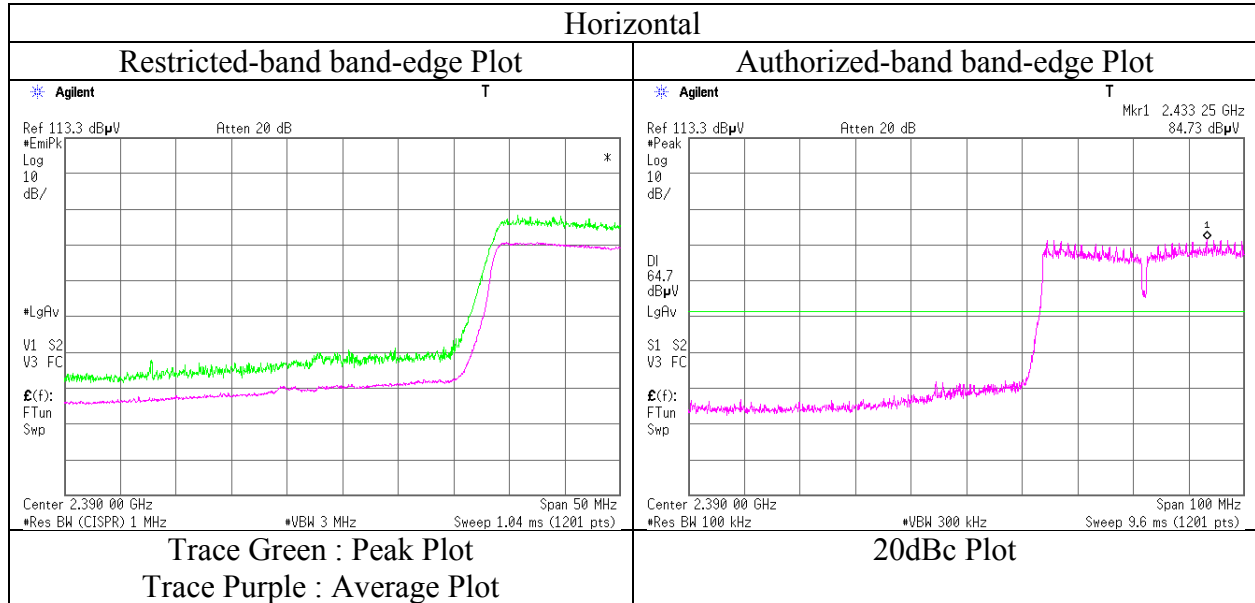

* Final result of restricted band edge was shown in tabular data.

Radiated Spurious Emission

Test place : Shonan EMC Lab. No.3 Semi Anechoic Chamber
Report No. : 11334871S-A-R1
Date : August 30, 2016
Temperature / Humidity : 23 deg.C / 61 %RH
Engineer : Makoto Hosaka

Mode : Tx 11n-40, SISO, 2462 MHz

(* PK: Peak, AV: Average, QP: Quasi-Peak)

Polarity	Frequency [MHz]	Detector	Reading [dBuV]	Ant.Fac. [dB/m]	Loss [dB]	Gain [dB]	Distance Factor [dB]	Result [dBuV/m]	Limit [dBuV/m]	Margin [dB]	Height [cm]	Angle [deg]	Remark
Hori.	2483.500	PK	55.48	27.91	13.91	40.69	2.28	58.89	73.90	15.0	136	113	
Vert.	2483.500	PK	57.30	27.91	13.91	40.69	2.28	60.71	73.90	13.1	136	95	

Result = Reading + Ant.Fac. + Loss (Cable+(Attenuator or Filter)(below 18 GHz)) - Gain(Amplifier) + Distance factor

Distance factor : 1 GHz - 13 GHz : $20\log(3.90\text{ m} / 3.0\text{ m}) = 2.28\text{ dB}$

13 GHz - 40 GHz : $20\log(1.0\text{ m} / 3.0\text{ m}) = -9.54\text{ dB}$

Average measurement value with duty factor

Polarity	Frequency [MHz]	Detector	Reading [dBuV]	Ant.Fac. [dB/m]	Loss [dB]	Gain [dB]	Duty Factor [dB]	Distance Factor [dB]	Result [dBuV/m]	Limit [dBuV/m]	Margin [dB]	Remark
Hori.	2483.500	AV	41.44	27.91	13.91	40.69	3.48	2.28	48.33	53.90	5.6	*1)
Vert.	2483.500	AV	42.68	27.91	13.91	40.69	3.48	2.28	49.57	53.90	4.3	*1)

Result = Reading + Ant.Fac. + Loss (Cable+(Attenuator or Filter)(below 18 GHz)) - Gain(Amplifier) + Duty factor + Distance factor

Distance factor : 1 GHz - 13 GHz : $20\log(3.90\text{ m} / 3.0\text{ m}) = 2.28\text{ dB}$

13 GHz - 40 GHz : $20\log(1.0\text{ m} / 3.0\text{ m}) = -9.54\text{ dB}$

Duty factor refer to "Duty factor Calculation chart" sheet.

*1) Not out of band emission (Leakage Power)

Radiated Spurious Emission
(Reference Plot for band-edge)

Test place	Shonan EMC Lab. No.3 Semi Anechoic Chamber
Report No.	11334871S-A-R1
Date	August 30, 2016
Temperature / Humidity	23 deg.C / 61 %RH
Engineer	Makoto Hosaka
Mode	Tx 11n-40, SISO, 2462 MHz

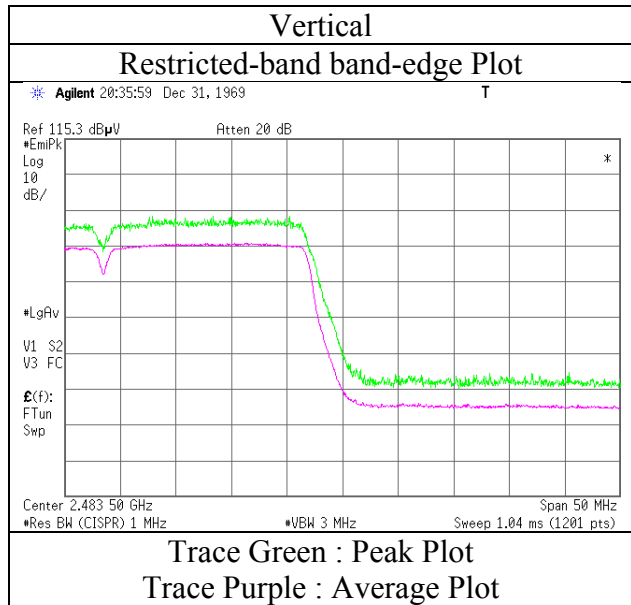
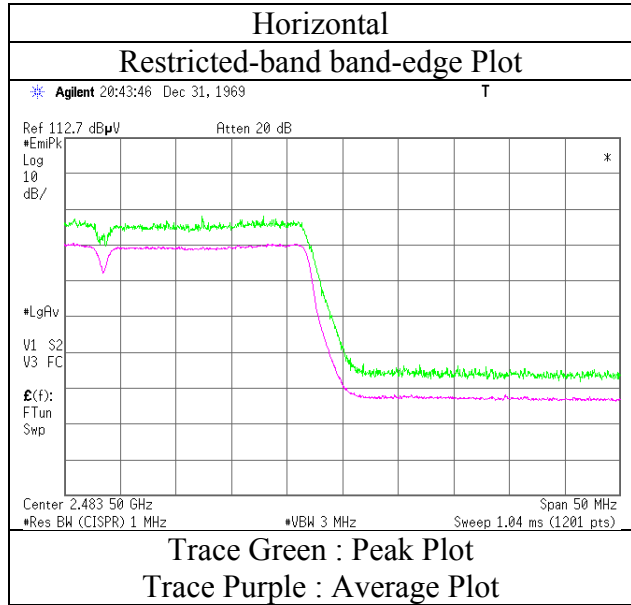

* Final result of restricted band edge was shown in tabular data.

Radiated Spurious Emission

Test place : Shonan EMC Lab. No.3 Semi Anechoic Chamber
Report No. : 11334871S-A-R1
Date : November 8, 2016 November 9, 2016
Temperature / Humidity : 22 deg.C / 28 %RH 22 deg.C / 36 %RH
Engineer : Hikaru Shirasawa Hikaru Shirasawa
(1 GHz - 18 GHz) (30 MHz - 1 GHz)
(18 GHz - 26.5 GHz)
Mode : Tx BT LE, 2402 MHz

(* PK: Peak, AV: Average, QP: Quasi-Peak)

Polarity	Frequency [MHz]	Detector	Reading [dBuV]	Ant.Fac. [dB/m]	Loss [dB]	Gain [dB]	Distance Factor [dB]	Result [dBuV/m]	Limit [dBuV/m]	Margin [dB]	Height [cm]	Angle [deg]	Remark
Hori.	120.011	QP	42.79	12.84	7.38	32.12	0.00	30.89	43.50	12.6	286	195	
Hori.	216.002	QP	46.57	11.72	8.22	32.03	0.00	34.48	46.00	11.5	156	214	
Hori.	240.009	QP	49.33	11.64	8.35	32.00	0.00	37.32	46.00	8.6	138	320	
Hori.	2390.000	PK	42.96	27.41	13.82	37.06	2.28	49.41	73.90	24.4	151	303	
Hori.	3202.737	PK	45.38	28.56	5.51	36.82	2.28	44.91	73.90	28.9	270	230	
Hori.	4804.000	PK	57.24	31.13	6.01	37.12	2.28	59.54	73.90	14.3	115	4	
Hori.	7206.000	PK	43.09	36.44	7.55	37.84	2.28	51.52	73.90	22.3	150	0	
Hori.	9608.000	PK	43.38	38.63	8.40	39.13	2.28	53.56	73.90	20.3	150	359	
Hori.	12010.000	PK	44.27	39.28	9.82	39.38	2.28	56.27	73.90	17.6	150	0	
Hori.	2390.000	AV	34.12	27.41	13.82	37.06	2.28	40.57	53.90	13.3	151	303	
Hori.	3202.737	AV	38.64	28.56	5.51	36.82	2.28	38.17	53.90	15.7	270	230	
Vert.	38.685	QP	32.77	14.73	6.78	32.18	0.00	22.10	40.00	17.9	100	224	
Vert.	120.004	QP	45.89	12.84	7.38	32.12	0.00	33.99	43.50	9.5	100	233	
Vert.	144.027	QP	38.89	14.52	7.81	32.10	0.00	29.12	43.50	14.3	100	241	
Vert.	168.004	QP	40.72	15.75	8.00	32.08	0.00	32.39	43.50	11.1	100	325	
Vert.	192.008	QP	36.59	16.25	7.94	32.06	0.00	28.72	43.50	14.7	100	186	
Vert.	799.466	QP	26.69	20.78	10.70	31.57	0.00	26.60	46.00	19.4	100	359	
Vert.	2390.000	PK	44.32	27.41	13.82	37.06	2.28	50.77	73.90	23.1	150	278	
Vert.	3202.737	PK	46.29	28.56	5.51	36.82	2.28	45.82	73.90	28.0	153	247	
Vert.	4804.000	PK	58.23	31.13	6.01	37.12	2.28	60.53	73.90	13.3	109	11	
Vert.	7206.000	PK	43.06	36.44	7.55	37.84	2.28	51.49	73.90	22.4	150	0	
Vert.	9608.000	PK	44.11	38.63	8.40	39.13	2.28	54.29	73.90	19.6	150	359	
Vert.	12010.000	PK	45.18	39.28	9.82	39.38	2.28	57.18	73.90	16.7	150	0	
Vert.	2390.000	AV	34.29	27.41	13.82	37.06	2.28	40.74	53.90	13.1	150	278	
Vert.	3202.737	AV	39.33	28.56	5.51	36.82	2.28	38.86	53.90	15.0	153	247	

Result = Reading + Ant.Fac. + Loss (Cable+(Attenuator or Filter)(below 18 GHz)) - Gain(Amplifier) + Distance factor

Distance factor : 1 GHz - 13 GHz : 20log(3.9 m / 3.0 m) = 2.28 dB

13 GHz - 40 GHz : 20log(1.0 m / 3.0 m) = -9.54 dB

Average measurement value with duty factor

Polarity	Frequency [MHz]	Detector	Reading [dBuV]	Ant.Fac. [dB/m]	Loss [dB]	Gain [dB]	Duty Factor [dB]	Distance Factor [dB]	Result [dBuV/m]	Limit [dBuV/m]	Margin [dB]	Remark
Hori.	4804.000	AV	51.14	31.13	6.01	37.12	-15.48	2.28	37.96	53.90	15.9	
Hori.	7206.000	AV	33.08	36.44	7.55	37.84	-15.48	2.28	26.03	53.90	27.9	
Hori.	9608.000	AV	34.62	38.63	8.40	39.13	-15.48	2.28	29.32	53.90	24.6	
Hori.	12010.000	AV	34.77	39.28	9.82	39.38	-15.48	2.28	31.29	53.90	22.6	
Vert.	4804.000	AV	52.77	31.13	6.01	37.12	-15.48	2.28	39.59	53.90	14.3	
Vert.	7206.000	AV	33.40	36.44	7.55	37.84	-15.48	2.28	26.35	53.90	27.6	
Vert.	9608.000	AV	34.38	38.63	8.40	39.13	-15.48	2.28	29.08	53.90	24.8	
Vert.	12010.000	AV	35.26	39.28	9.82	39.38	-15.48	2.28	31.78	53.90	22.1	

Result = Reading + Ant.Fac. + Loss (Cable+(Attenuator or Filter)(below 18 GHz)) - Gain(Amplifier) + Duty factor + Distance factor

Distance factor : 1 GHz - 13 GHz : 20log(3.9 m / 3.0 m) = 2.28 dB

13 GHz - 40 GHz : 20log(1.0 m / 3.0 m) = -9.54 dB

Duty factor refer to "Burst rate confirmation chart" sheet & "Averaging factor" sheet.

20 dBc Data Sheet (RBW 100 kHz, VBW 300 kHz)

Polarity	Frequency [MHz]	Detector	Reading [dBuV]	Ant.Fac. [dB/m]	Loss [dB]	Gain [dB]	Distance Factor [dB]	Result [dBuV/m]	Limit [dBuV/m]	Margin [dB]	Remark
Hori.	2402.000	PK	82.31	27.46	13.83	37.05	2.28	88.83	-	-	Carrier
Hori.	2400.000	PK	34.56	27.45	13.83	37.05	2.28	41.07	68.83	27.8	
Vert.	2402.000	PK	86.50	27.46	13.83	37.05	2.28	93.02	-	-	Carrier
Vert.	2400.000	PK	34.70	27.45	13.83	37.05	2.28	41.21	73.02	31.8	

Result = Reading + Ant.Fac. + Loss (Cable+(Attenuator or Filter)(below 18 GHz)) - Gain(Amplifier) + Distance factor

Distance factor : 1 GHz - 13 GHz : 20log(3.9 m / 3.0 m) = 2.28 dB

13 GHz - 40 GHz : 20log(1.0 m / 3.0 m) = -9.54 dB

UL Japan, Inc.

Shonan EMC Lab.

1-22-3 Megumigaoka, Hiratsuka-shi, Kanagawa-ken, 259-1220 JAPAN

Telephone : +81 463 50 6400

Facsimile : +81 463 50 6401

Radiated Spurious Emission
(Reference Plot for band-edge)

Test place : Shonan EMC Lab. No.3 Semi Anechoic Chamber
Report No. : 11334871S-A-R1
Date : November 8, 2016
Temperature / Humidity : 22 deg.C / 28 %RH
Engineer : Hikaru Shirasawa
Mode : Tx BT LE, 2402 MHz

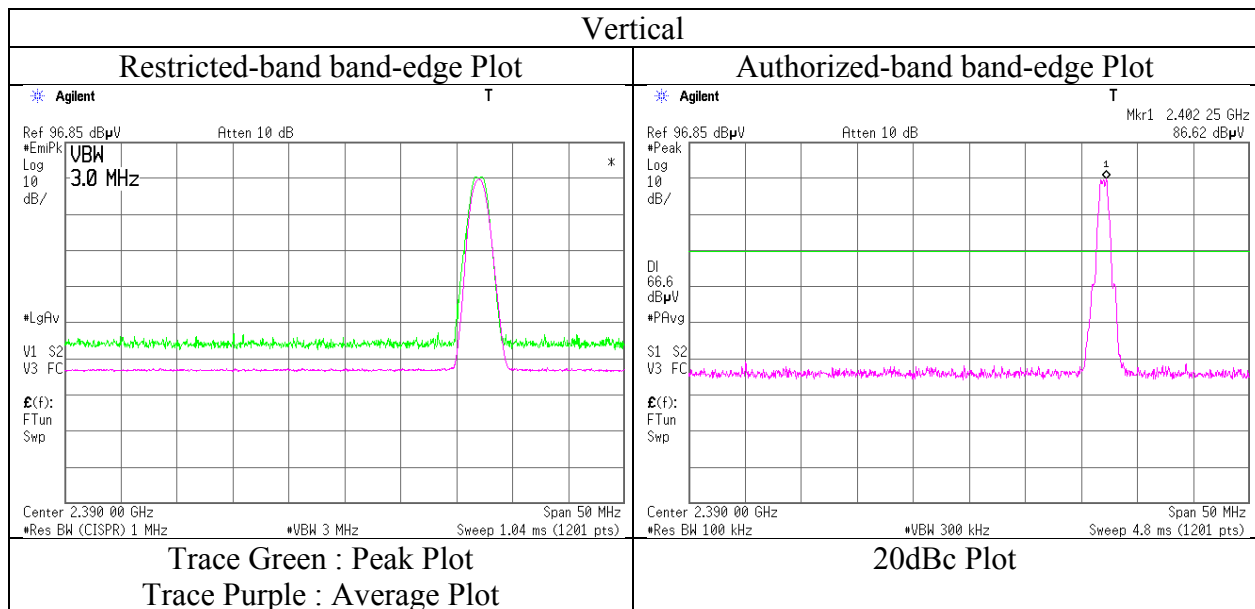
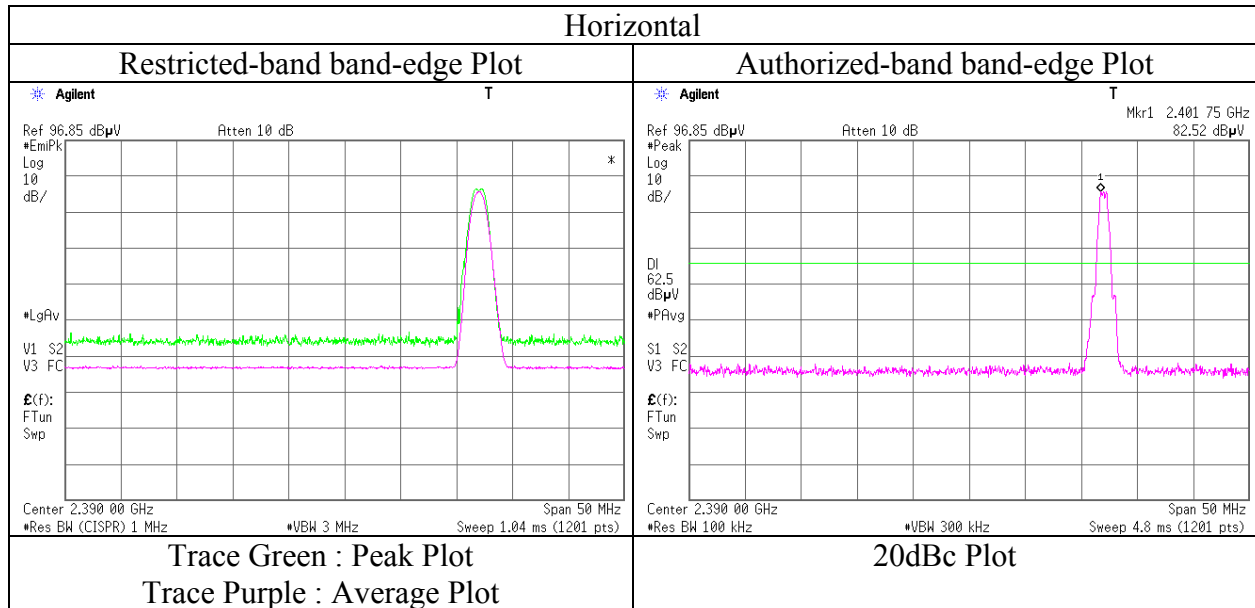

* Final result of restricted band edge was shown in tabular data.

Radiated Spurious Emission

Test place : Shonan EMC Lab. No.3 Semi Anechoic Chamber
Report No. : 11334871S-A-R1
Date : November 8, 2016 November 9, 2016
Temperature / Humidity : 22 deg.C / 28 %RH 22 deg.C / 36 %RH
Engineer : Hikaru Shirasawa Hikaru Shirasawa
(1 GHz - 18 GHz) (30 MHz - 1 GHz)
(18 GHz - 26.5 GHz)
Mode : Tx BT LE, 2440 MHz

(* PK: Peak, AV: Average, QP: Quasi-Peak)

Polarity	Frequency [MHz]	Detector	Reading [dBuV]	Ant.Fac. [dB/m]	Loss [dB]	Gain [dB]	Distance Factor [dB]	Result [dBuV/m]	Limit [dBuV/m]	Margin [dB]	Height [cm]	Angle [deg]	Remark
Hori.	120.003	QP	42.87	12.84	7.38	32.12	0.00	30.97	43.50	12.5	308	201	
Hori.	216.005	QP	46.78	11.72	8.22	32.03	0.00	34.69	46.00	11.3	146	217	
Hori.	239.999	QP	49.05	11.64	8.35	32.00	0.00	37.04	46.00	8.9	137	321	
Hori.	3253.303	PK	45.80	28.59	5.52	36.81	2.28	45.38	73.90	28.5	149	246	
Hori.	4880.000	PK	59.10	31.29	6.04	37.15	2.28	61.56	73.90	12.3	116	10	
Hori.	7320.000	PK	43.82	36.77	7.59	37.91	2.28	52.55	73.90	21.3	150	359	
Hori.	9760.000	PK	44.51	38.75	8.49	39.19	2.28	54.84	73.90	19.0	150	0	
Hori.	12200.000	PK	44.97	39.30	9.95	39.39	2.28	57.11	73.90	16.7	150	359	
Hori.	3253.303	AV	38.54	28.59	5.52	36.81	2.28	38.12	53.90	15.7	149	246	
Vert.	38.619	QP	33.25	14.75	6.78	32.18	0.00	22.60	40.00	17.4	100	222	
Vert.	120.006	QP	45.82	12.84	7.38	32.12	0.00	33.92	43.50	9.5	100	236	
Vert.	144.011	QP	39.01	14.52	7.81	32.10	0.00	29.24	43.50	14.2	100	250	
Vert.	168.012	QP	40.63	15.75	8.00	32.08	0.00	32.30	43.50	11.2	100	324	
Vert.	192.016	QP	36.40	16.25	7.94	32.06	0.00	28.53	43.50	14.9	100	179	
Vert.	799.475	QP	26.14	20.78	10.70	31.57	0.00	26.05	46.00	19.9	100	359	
Vert.	3253.303	PK	45.62	28.59	5.52	36.81	2.28	45.20	73.90	28.7	143	239	
Vert.	4880.000	PK	59.10	31.29	6.04	37.15	2.28	61.56	73.90	12.3	115	19	
Vert.	7320.000	PK	43.39	36.77	7.59	37.91	2.28	52.12	73.90	21.7	150	359	
Vert.	9760.000	PK	45.14	38.75	8.49	39.19	2.28	55.47	73.90	18.4	150	0	
Vert.	12200.000	PK	44.61	39.30	9.95	39.39	2.28	56.75	73.90	17.1	150	359	
Vert.	3253.303	AV	39.36	28.59	5.52	36.81	2.28	38.94	53.90	14.9	143	239	

Result = Reading + Ant.Fac. + Loss (Cable+(Attenuator or Filter)(below 18 GHz)) - Gain(Amplifier) + Distance factor

Distance factor : 1 GHz - 13 GHz : 20log(3.9 m / 3.0 m) = 2.28 dB

13 GHz - 40 GHz : 20log(1.0 m / 3.0 m) = -9.54 dB

Average measurement value with duty factor

Polarity	Frequency [MHz]	Detector	Reading [dBuV]	Ant.Fac. [dB/m]	Loss [dB]	Gain [dB]	Duty Factor [dB]	Distance Factor [dB]	Result [dBuV/m]	Limit [dBuV/m]	Margin [dB]	Remark
Hori.	4880.000	AV	53.76	31.29	6.04	37.15	-15.48	2.28	40.74	53.90	13.2	
Hori.	7320.000	AV	34.02	36.77	7.59	37.91	-15.48	2.28	27.27	53.90	26.6	
Hori.	9760.000	AV	34.97	38.75	8.49	39.19	-15.48	2.28	29.82	53.90	24.1	
Hori.	12200.000	AV	35.06	39.30	9.95	39.39	-15.48	2.28	31.72	53.90	22.2	
Vert.	4880.000	AV	53.33	31.29	6.04	37.15	-15.48	2.28	40.31	53.90	13.6	
Vert.	7320.000	AV	33.58	36.77	7.59	37.91	-15.48	2.28	26.83	53.90	27.1	
Vert.	9760.000	AV	35.33	38.75	8.49	39.19	-15.48	2.28	30.18	53.90	23.7	
Vert.	12200.000	AV	35.37	39.30	9.95	39.39	-15.48	2.28	32.03	53.90	21.9	

Result = Reading + Ant.Fac. + Loss (Cable+(Attenuator or Filter)(below 18 GHz)) - Gain(Amplifier) + Duty factor + Distance factor

Distance factor : 1 GHz - 13 GHz : 20log(3.9 m / 3.0 m) = 2.28 dB

13 GHz - 40 GHz : 20log(1.0 m / 3.0 m) = -9.54 dB

Duty factor refer to "Burst rate confirmation chart" sheet & "Averaging factor" sheet.

Radiated Spurious Emission

Test place : Shonan EMC Lab. No.3 Semi Anechoic Chamber
Report No. : 11334871S-A-R1
Date : November 8, 2016 November 9, 2016
Temperature / Humidity : 22 deg.C / 28 %RH 22 deg.C / 36 %RH
Engineer : Hikaru Shirasawa Hikaru Shirasawa
(1 GHz - 18 GHz) (30 MHz - 1 GHz)
(18 GHz - 26.5 GHz)
Mode : Tx BT LE, 2480 MHz

(* PK: Peak, AV: Average, QP: Quasi-Peak)

Polarity	Frequency [MHz]	Detector	Reading [dBuV]	Ant.Fac. [dB/m]	Loss [dB]	Gain [dB]	Distance Factor [dB]	Result [dBuV/m]	Limit [dBuV/m]	Margin [dB]	Height [cm]	Angle [deg]	Remark
Hori.	120.004	QP	43.01	12.84	7.38	32.12	0.00	31.11	43.50	12.3	307	201	
Hori.	216.009	QP	46.66	11.72	8.22	32.03	0.00	34.57	46.00	11.4	150	213	
Hori.	240.002	QP	49.28	11.64	8.35	32.00	0.00	37.27	46.00	8.7	136	318	
Hori.	2483.500	PK	42.52	27.79	13.91	37.01	2.28	49.49	73.90	24.4	148	301	
Hori.	3306.644	PK	44.19	28.63	5.53	36.80	2.28	43.83	73.90	30.0	100	196	
Hori.	4960.000	PK	54.63	31.45	6.06	37.19	2.28	57.23	73.90	16.6	116	8	
Hori.	7440.000	PK	43.83	37.11	7.63	37.99	2.28	52.86	73.90	21.0	150	359	
Hori.	9920.000	PK	45.14	38.87	8.57	39.26	2.28	55.60	73.90	18.3	150	0	
Hori.	12400.000	PK	44.84	39.32	10.10	39.40	2.28	57.14	73.90	16.7	150	359	
Hori.	2483.500	AV	34.11	27.79	13.91	37.01	2.28	41.08	53.90	12.8	148	301	
Hori.	3306.644	AV	36.69	28.63	5.53	36.80	2.28	36.33	53.90	17.5	100	196	
Vert.	38.493	QP	33.08	14.79	6.78	32.18	0.00	22.47	40.00	17.5	100	217	
Vert.	120.005	QP	45.87	12.84	7.38	32.12	0.00	33.97	43.50	9.5	100	238	
Vert.	144.018	QP	38.74	14.52	7.81	32.10	0.00	28.97	43.50	14.5	100	249	
Vert.	168.011	QP	40.61	15.75	8.00	32.08	0.00	32.28	43.50	11.2	100	328	
Vert.	192.014	QP	36.27	16.25	7.94	32.06	0.00	28.40	43.50	15.1	100	203	
Vert.	799.816	QP	25.28	20.79	10.70	31.57	0.00	25.20	46.00	20.8	100	359	
Vert.	2483.500	PK	42.94	27.79	13.91	37.01	2.28	49.91	73.90	23.9	200	293	
Vert.	3306.644	PK	44.02	28.63	5.53	36.80	2.28	43.66	73.90	30.2	100	327	
Vert.	4960.000	PK	54.10	31.45	6.06	37.19	2.28	56.70	73.90	17.2	110	13	
Vert.	7440.000	PK	43.16	37.11	7.63	37.99	2.28	52.19	73.90	21.7	150	0	
Vert.	9920.000	PK	45.47	38.87	8.57	39.26	2.28	55.93	73.90	17.9	150	359	
Vert.	12400.000	PK	44.97	39.32	10.10	39.40	2.28	57.27	73.90	16.6	150	0	
Vert.	2483.500	AV	34.32	27.79	13.91	37.01	2.28	41.29	53.90	12.6	200	293	
Vert.	3306.644	AV	36.26	28.63	5.53	36.80	2.28	35.90	53.90	18.0	100	327	

Result = Reading + Ant.Fac. + Loss (Cable+(Attenuator or Filter)(below 18 GHz)) - Gain(Amplifier) + Distance factor

Distance factor : 1 GHz - 13 GHz : $20\log(3.9\text{ m} / 3.0\text{ m}) = 2.28\text{ dB}$

13 GHz - 40 GHz : $20\log(1.0\text{ m} / 3.0\text{ m}) = -9.54\text{ dB}$

Average measurement value with duty factor

Polarity	Frequency [MHz]	Detector	Reading [dBuV]	Ant.Fac. [dB/m]	Loss [dB]	Gain [dB]	Duty Factor [dB]	Distance Factor [dB]	Result [dBuV/m]	Limit [dBuV/m]	Margin [dB]	Remark
Hori.	4960.000	AV	48.69	31.45	6.06	37.19	-15.48	2.28	35.81	53.90	18.1	
Hori.	7440.000	AV	33.65	37.11	7.63	37.99	-15.48	2.28	27.20	53.90	26.7	
Hori.	9920.000	AV	35.05	38.87	8.57	39.26	-15.48	2.28	30.03	53.90	23.9	
Hori.	12400.000	AV	35.33	39.32	10.10	39.40	-15.48	2.28	32.15	53.90	21.8	
Vert.	4960.000	AV	48.42	31.45	6.06	37.19	-15.48	2.28	35.54	53.90	18.4	
Vert.	7440.000	AV	33.66	37.11	7.63	37.99	-15.48	2.28	27.21	53.90	26.7	
Vert.	9920.000	AV	35.63	38.87	8.57	39.26	-15.48	2.28	30.61	53.90	23.3	
Vert.	12400.000	AV	35.35	39.32	10.10	39.40	-15.48	2.28	32.17	53.90	21.7	

Result = Reading + Ant.Fac. + Loss (Cable+(Attenuator or Filter)(below 18 GHz)) - Gain(Amplifier) + Duty factor + Distance factor

Distance factor : 1 GHz - 13 GHz : $20\log(3.9\text{ m} / 3.0\text{ m}) = 2.28\text{ dB}$

13 GHz - 40 GHz : $20\log(1.0\text{ m} / 3.0\text{ m}) = -9.54\text{ dB}$

Duty factor refer to "Burst rate confirmation chart" sheet & "Averaging factor" sheet.

UL Japan, Inc.

Shonan EMC Lab.

1-22-3 Megumigaoka, Hiratsuka-shi, Kanagawa-ken, 259-1220 JAPAN

Telephone : +81 463 50 6400

Facsimile : +81 463 50 6401

Radiated Spurious Emission
(Reference Plot for band-edge)

Test place	Shonan EMC Lab. No.3 Semi Anechoic Chamber
Report No.	11334871S-A-R1
Date	November 8, 2016
Temperature / Humidity	22 deg.C / 28 %RH
Engineer	Hikaru Shirasawa
Mode	Tx BT LE, 2480 MHz

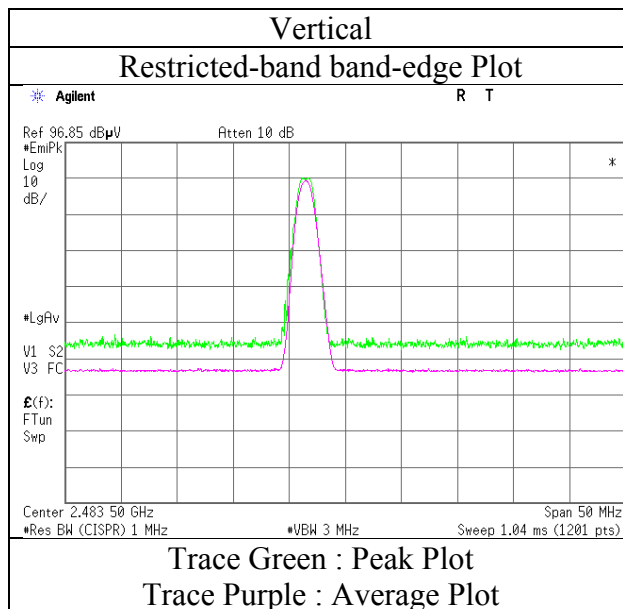
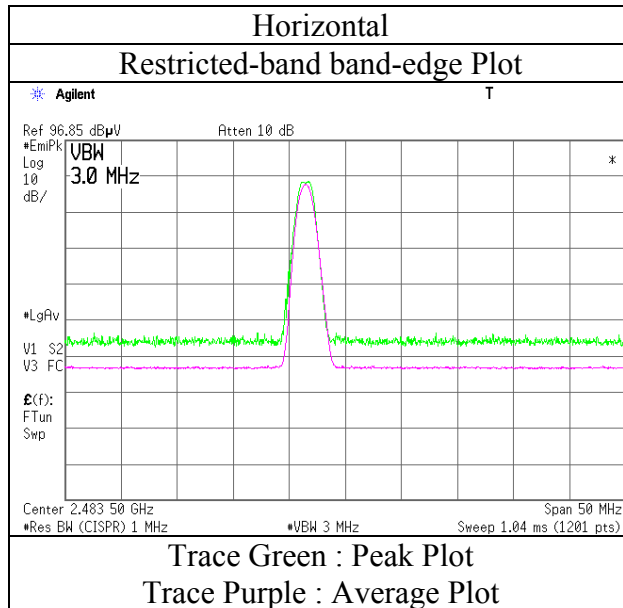

* Final result of restricted band edge was shown in tabular data.

Radiated Spurious Emission
(Plot data, Worst case)

Test place	Shonan EMC Lab. No.3 Semi Anechoic Chamber			
Report No.	11334871S-A-R1			
Date	August 30, 2016	October 24, 2016	October 26, 2016	November 10, 2016
Temperature / Humidity	22 deg.C / 70 %RH	25 deg.C / 58 %RH	25 deg.C / 49 %RH	23 deg.C / 35 %RH
Engineer	Makoto Hosaka (1 GHz - 2.8 GHz)	Hikaru Shirasawa (2.8 GHz - 13 GHz)	Hikaru Shirasawa (13 GHz - 18 GHz)	Shinichi Takano (30 MHz - 1 GHz), (18 GHz - 26 GHz)
Mode	Tx OFDM, VHT20, MIMO, 2437 MHz			

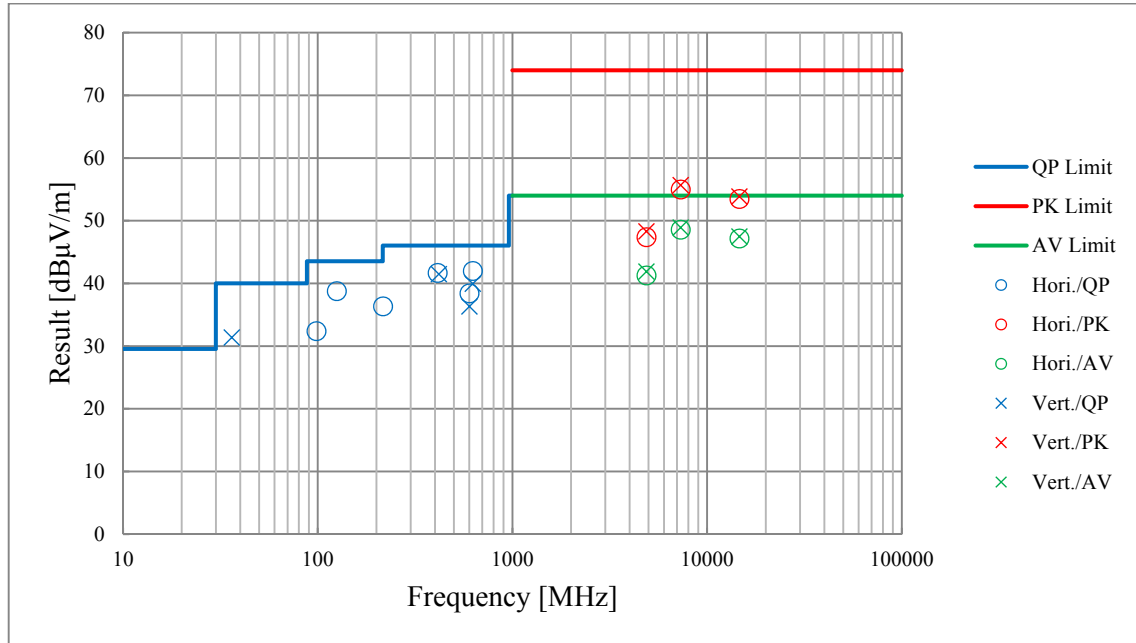

*These plots data contains sufficient number to show the trend of characteristic features for EUT.

Radiated Spurious Emission (Plot data, Worst case)

Test place	Shonan EMC Lab. No.3 Semi Anechoic Chamber	
Report No.	11334871S-A-R1	
Date	November 8, 2016	November 9, 2016
Temperature / Humidity	22 deg.C / 28 %RH	22 deg.C / 36 %RH
Engineer	Hikaru Shirasawa (1 GHz - 18 GHz)	Hikaru Shirasawa (30 MHz - 1 GHz) (18 GHz - 26 GHz)
Mode	Tx BT LE, 2480 MHz	

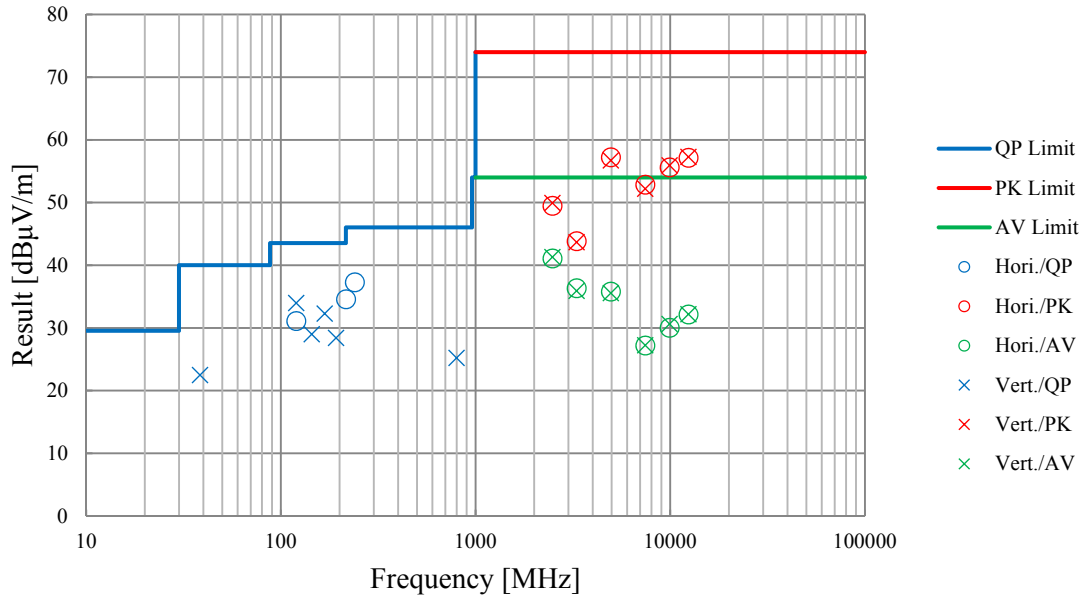

*These plots data contains sufficient number to show the trend of characteristic features for EUT.

Conducted Spurious Emission

Test place	Shonan EMC Lab. No.1 Measurement Room
Report No.	11334871S-A-R1
Date	November 4, 2016
Temperature / Humidity	24 deg. C / 40 % RH
Engineer	Kenichi Adachi
Mode	Tx OFDM, VHT20, MIMO, 2437 MHz

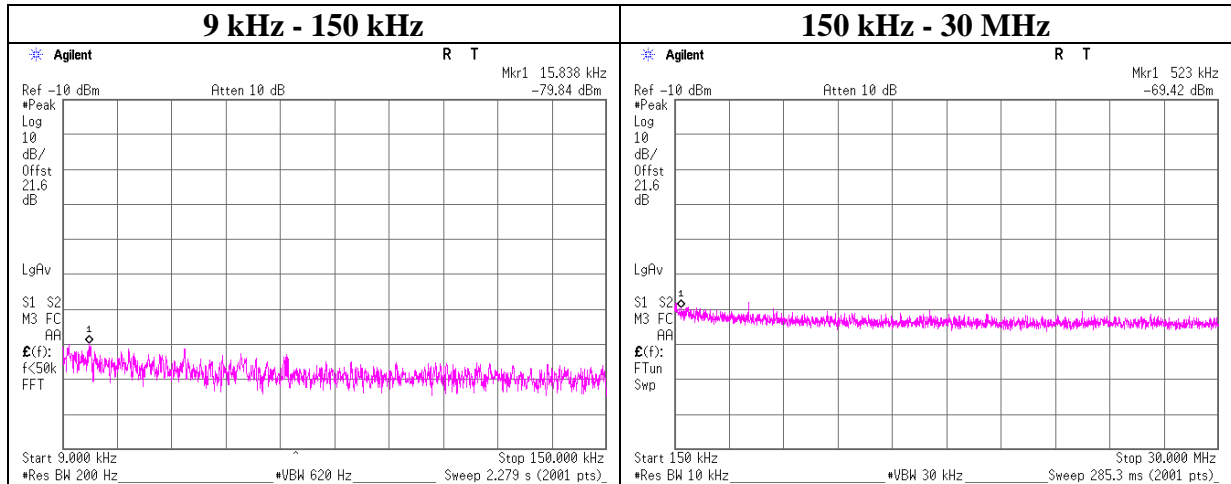

Frequency [kHz]	Reading [dBm]	Cable Loss [dB]	Attenuator Loss [dB]	Antenna Gain [dBi]	N (Number of Output)	EIRP [dBm]	Distance [m]	Ground bounce [dB]	E (field strength) [dBuV/m]	Limit [dBuV/m]	Margin [dB]	Remark
0.02	-79.8	2.12	20.2	2.0	2	-52.5	300	6.0	8.8	103.6	94.8	
0.52	-69.4	2.12	20.2	2.0	2	-42.1	300	6.0	19.2	73.2	54.0	

$E = \text{EIRP} - 20 \log(D) + \text{Ground bounce} + 104.8 \text{ [dBuV/m]}$

$\text{EIRP} = \text{Reading} + \text{Cable Loss} + \text{Attenuator Loss} + \text{Antenna Gain} + 10 * \log(N)$

- *) No detect noise signal was in frequency range from 9 kHz to 30 MHz.
- *) The antenna gain applied 2 dBi of section 12.2.6 of FCC KDB 558074 D01.

Conducted Spurious Emissions

Test place	Shonan EMC Lab. No.1 Measurement Room
Report No.	11334871S-A-R1
Date	November 11, 2016
Temperature / Humidity	25 deg. C / 33 % RH
Engineer	Hikaru Shirasawa
Mode	Tx BT LE, 2402 MHz

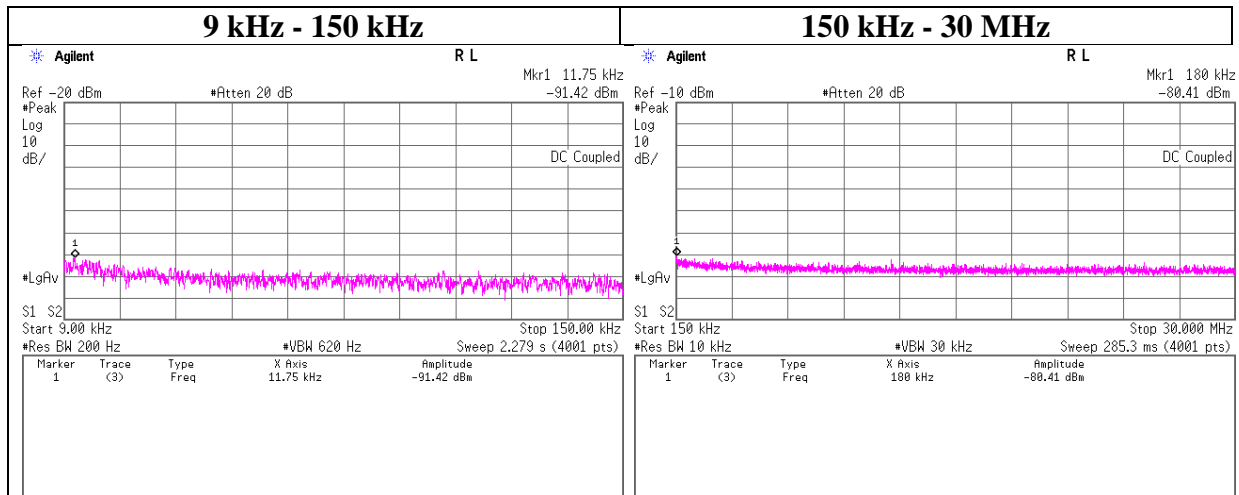

Frequency	Reading	Cable Loss	Attenuator Loss	Antenna Gain	N	EIRP	Distance	Ground bounce	E (field strength)	Limit	Margin	Remark
[kHz]	[dBm]	[dB]	[dB]	[dBi]	(Number of Output)	[dBm]	[m]	[dB]	[dBuV/m]	[dBuV/m]	[dB]	
11.75	-91.4	2.12	9.9	2.0	1	-77.4	300	6.0	-16.1	46.2	62.3	
180.00	-80.4	2.12	9.9	2.0	1	-66.3	300	6.0	-5.1	22.4	27.5	

$E = \text{EIRP} - 20 \log(D) + \text{Ground bounce} + 104.8 \text{ [dBuV/m]}$

$\text{EIRP} = \text{Reading} + \text{Cable Loss} + \text{Attenuator Loss} + \text{Antenna Gain} + 10 * \log(N)$

- *) No detect noise signal was in frequency range from 9 kHz to 30 MHz.
- *) The antenna gain applied 2 dBi of section 12.2.6 of FCC KDB 558074 D01.

Conducted Spurious Emissions

Test place	Shonan EMC Lab. No.1 Measurement Room
Report No.	11334871S-A-R1
Date	November 11, 2016
Temperature / Humidity	25 deg. C / 33 % RH
Engineer	Hikaru Shirasawa
Mode	Tx BT LE, 2440 MHz

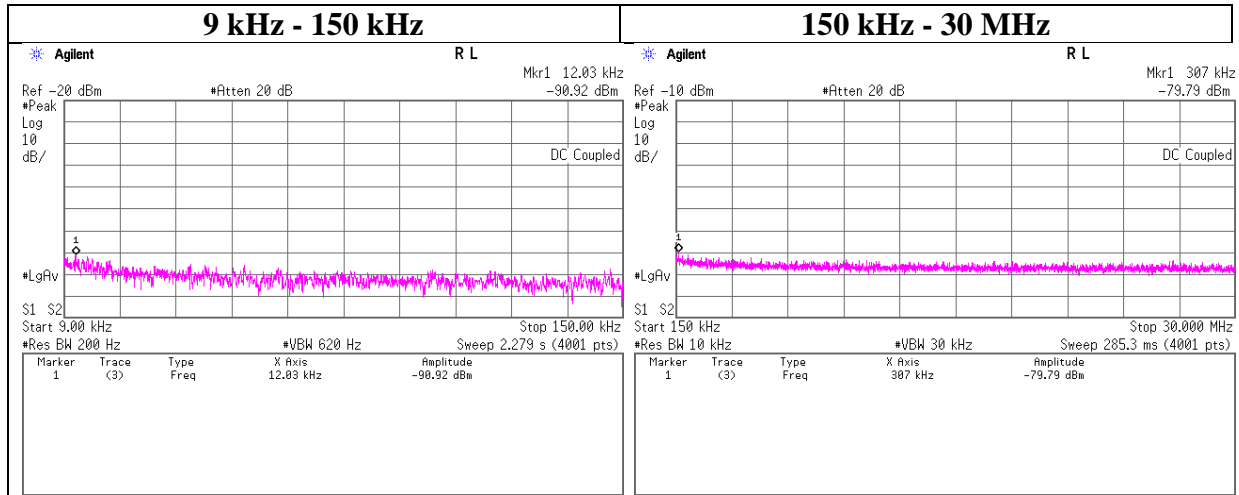

Frequency	Reading	Cable Loss	Attenuator Loss	Antenna Gain	N	EIRP	Distance	Ground bounce	E (field strength)	Limit	Margin	Remark
[kHz]	[dBm]	[dB]	[dB]	[dBi]	(Number of Output)	[dBm]	[m]	[dB]	[dBuV/m]	[dBuV/m]	[dB]	
12.03	-90.9	2.12	9.9	2.0	1	-76.9	300	6.0	-15.6	45.9	61.5	
307.00	-79.8	2.12	9.9	2.0	1	-65.7	300	6.0	-4.5	17.8	22.3	

$E = \text{EIRP} - 20 \log(D) + \text{Ground bounce} + 104.8 \text{ [dBuV/m]}$

$\text{EIRP} = \text{Reading} + \text{Cable Loss} + \text{Attenuator Loss} + \text{Antenna Gain} + 10 * \log(N)$

*) No detect noise signal was in frequency range from 9 kHz to 30 MHz.

*) The antenna gain applied 2 dBi of section 12.2.6 of FCC KDB 558074 D01.

Conducted Spurious Emissions

Test place	Shonan EMC Lab. No.1 Measurement Room
Report No.	11334871S-A-R1
Date	November 11, 2016
Temperature / Humidity	25 deg. C / 33 % RH
Engineer	Hikaru Shirasawa
Mode	Tx BT LE, 2480 MHz

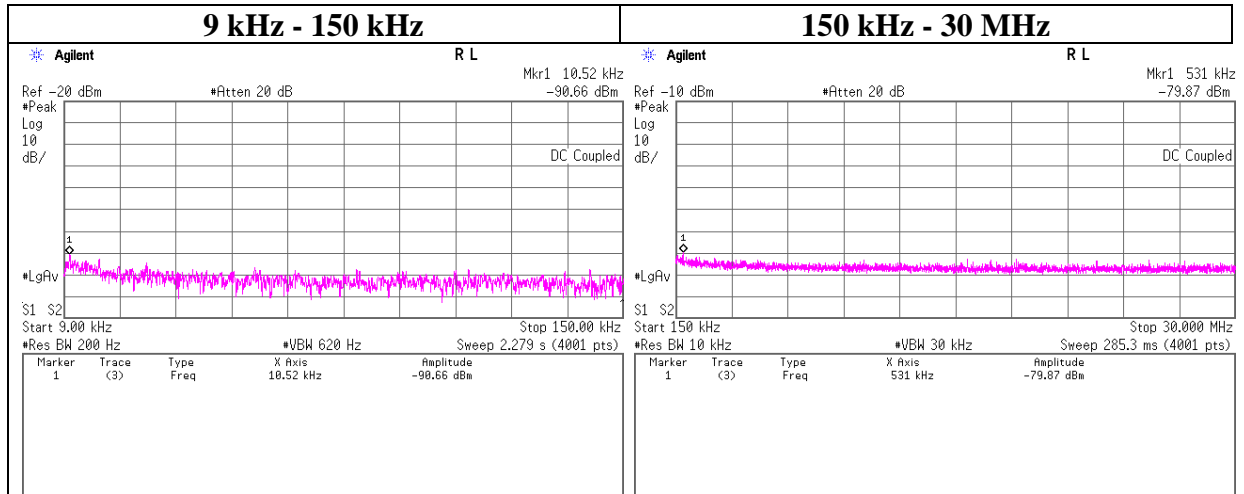

Frequency [kHz]	Reading [dBm]	Cable Loss [dB]	Attenuator Loss [dB]	Antenna Gain [dBi]	N (Number of Output)	EIRP [dBm]	Distance [m]	Ground bounce [dB]	E (field strength) [dBuV/m]	Limit [dBuV/m]	Margin [dB]	Remark
10.52	-90.7	2.12	9.9	2.0	1	-76.6	300	6.0	-15.3	47.1	62.4	
531.00	-79.9	2.12	9.9	2.0	1	-65.8	30	6.0	15.5	33.1	17.6	

$E = \text{EIRP} - 20 \log(D) + \text{Ground bounce} + 104.8 \text{ [dBuV/m]}$

$\text{EIRP} = \text{Reading} + \text{Cable Loss} + \text{Attenuator Loss} + \text{Antenna Gain} + 10 * \log(N)$

*) No detect noise signal was in frequency range from 9 kHz to 30 MHz.

*) The antenna gain applied 2 dBi of section 12.2.6 of FCC KDB 558074 D01.

Power Density

Test place Shonan EMC Lab. No.1 Measurement Room
Report No. 11334871S-A-R1
Date October 21, 2016 November 2, 2016
Temperature / Humidity 26 deg. C / 45 % RH 24 deg. C / 36 % RH
Engineer Kenichi Adachi Kenichi Adachi
Mode Tx, SISO

11b Antenna: 1

Freq.	Frequency Reading	Reading	Cable Loss	Atten. Loss	Result	Limit	Margin
[MHz]	[MHz]	[dBm]	[dB]	[dB]	[dBm]	[dBm]	[dB]
2412.00	2410.48	-27.80	2.04	20.22	-5.54	8.00	13.54
2437.00	2435.93	-28.25	2.04	20.23	-5.98	8.00	13.98
2462.00	2461.81	-27.93	2.05	20.23	-5.65	8.00	13.65
2467.00	2467.76	-37.84	2.05	20.23	-15.56	8.00	23.56
2472.00	2473.14	-42.10	2.05	20.23	-19.82	8.00	27.82

11g (2412 MHz - 2462 MHz)Antenna: 0, (2467 MHz - 2472 MHz)Antenna 1

Freq.	Frequency Reading	Reading	Cable Loss	Atten. Loss	Result	Limit	Margin
[MHz]	[MHz]	[dBm]	[dB]	[dB]	[dBm]	[dBm]	[dB]
2412.00	2414.56	-35.54	2.11	20.22	-13.21	8.00	21.21
2437.00	2439.56	-35.26	2.11	20.23	-12.92	8.00	20.92
2462.00	2464.56	-35.23	2.12	20.23	-12.88	8.00	20.88
2467.00	2469.56	-41.66	2.12	20.23	-19.31	8.00	27.31
2472.00	2474.56	-46.32	2.12	20.23	-23.97	8.00	31.97

11n-20 Antenna: 1

Freq.	Frequency Reading	Reading	Cable Loss	Atten. Loss	Result	Limit	Margin
[MHz]	[MHz]	[dBm]	[dB]	[dB]	[dBm]	[dBm]	[dB]
2412.00	2416.32	-31.88	2.04	20.22	-9.62	8.00	17.62
2437.00	2438.28	-31.72	2.04	20.23	-9.45	8.00	17.45
2462.00	2456.92	-31.89	2.05	20.23	-9.61	8.00	17.61
2467.00	2461.92	-40.00	2.05	20.23	-17.72	8.00	25.72
2472.00	2473.28	-44.26	2.05	20.23	-21.98	8.00	29.98

OFDM VHT20 Antenna: 1

Freq.	Frequency Reading	Reading	Cable Loss	Atten. Loss	Result	Limit	Margin
[MHz]	[MHz]	[dBm]	[dB]	[dB]	[dBm]	[dBm]	[dB]
2412.00	2416.32	-31.47	1.36	20.22	-9.89	8.00	17.89
2437.00	2440.33	-30.81	1.37	20.23	-9.21	8.00	17.21
2462.00	2460.38	-31.08	1.37	20.23	-9.48	8.00	17.48
2467.00	2464.10	-39.70	1.37	20.23	-18.10	8.00	26.10
2472.00	2472.28	-43.37	1.37	20.23	-21.77	8.00	29.77

Sample Calculation:
Result = Reading + Cable Loss (including the cable(s) customer supplied) + Attenuator
*The equipment and cables were not used for factor 0 dB of the data sheets.

Power Density

Test place Shonan EMC Lab. No.1 Measurement Room
Report No. 11334871S-A-R1
Date November 4, 2016
Temperature / Humidity 24 deg. C / 40 % RH
Engineer Kenichi Adachi
Mode Tx, SISO

11n-40 Antenna: 0

Freq. [MHz]	Frequency Reading [MHz]	Reading [dBm]	Cable Loss [dB]	Atten. Loss [dB]	Result [dBm]	Limit [dBm]	Margin [dB]
2422.00	2416.96	-39.69	1.43	20.23	-18.03	8.00	26.03
2437.00	2434.80	-40.79	1.44	20.23	-19.12	8.00	27.12
2452.00	2438.30	-40.45	1.44	20.23	-18.78	8.00	26.78
2457.00	2450.77	-40.39	1.44	20.23	-18.72	8.00	26.72
2462.00	2456.96	-41.75	1.44	20.23	-20.08	8.00	28.08

OFDM VHT40 Antenna: 0

Freq. [MHz]	Frequency Reading [MHz]	Reading [dBm]	Cable Loss [dB]	Atten. Loss [dB]	Result [dBm]	Limit [dBm]	Margin [dB]
2422.00	2428.28	-40.35	1.43	20.23	-18.69	8.00	26.69
2437.00	2453.18	-40.69	1.44	20.23	-19.02	8.00	27.02
2452.00	2435.73	-40.89	1.44	20.23	-19.22	8.00	27.22
2457.00	2462.00	-39.90	1.44	20.23	-18.23	8.00	26.23
2462.00	2452.28	-40.38	1.44	20.23	-18.71	8.00	26.71

Sample Calculation:

Result = Reading + Cable Loss (including the cable(s) customer supplied) + Attenuator

*The equipment and cables were not used for factor 0 dB of the data sheets.

Power Density

11b

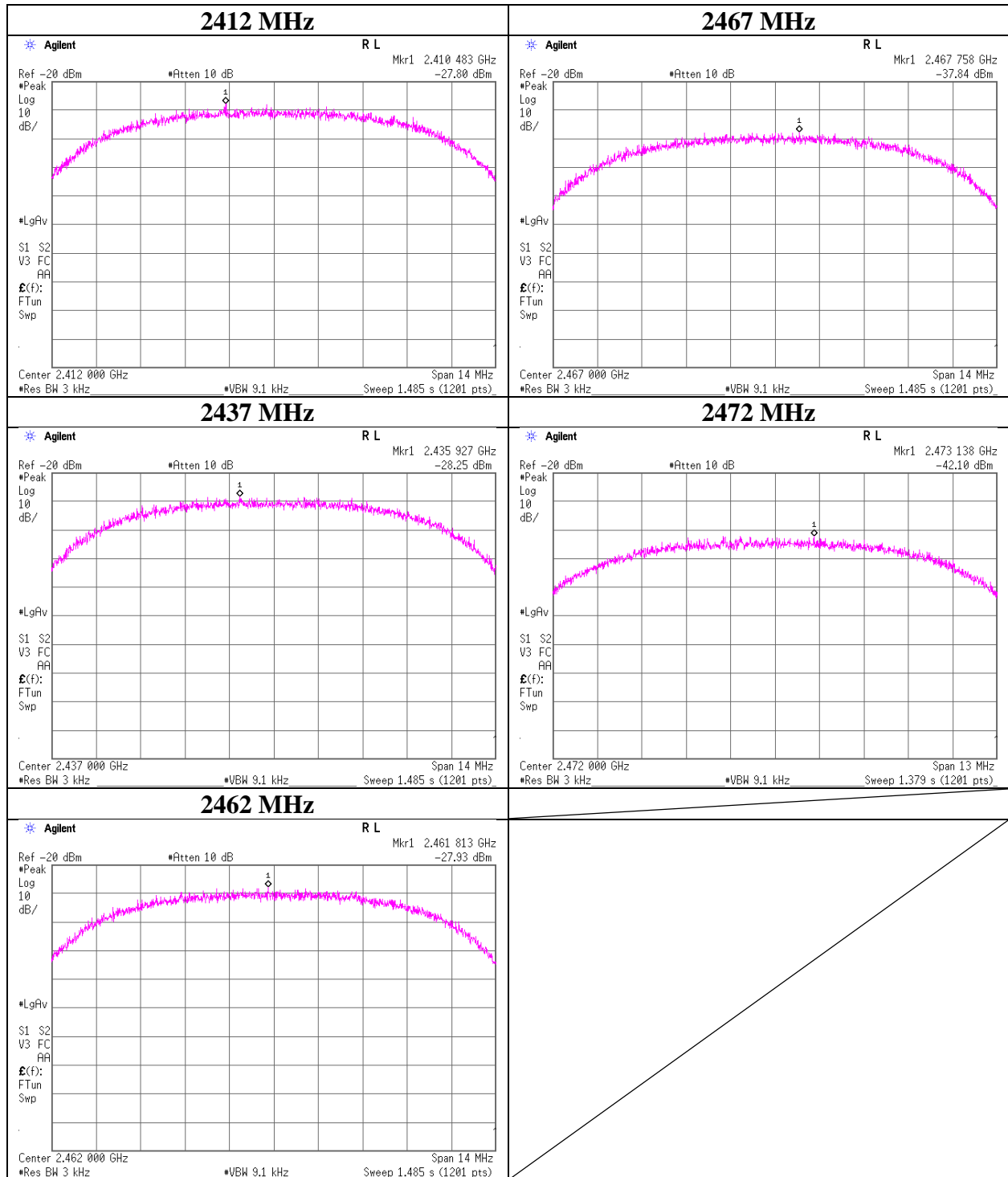

UL Japan, Inc.

Shonan EMC Lab.

1-22-3 Megumigaoka, Hiratsuka-shi, Kanagawa-ken, 259-1220 JAPAN

Telephone : +81 463 50 6400

Facsimile : +81 463 50 6401

Power Density

11g

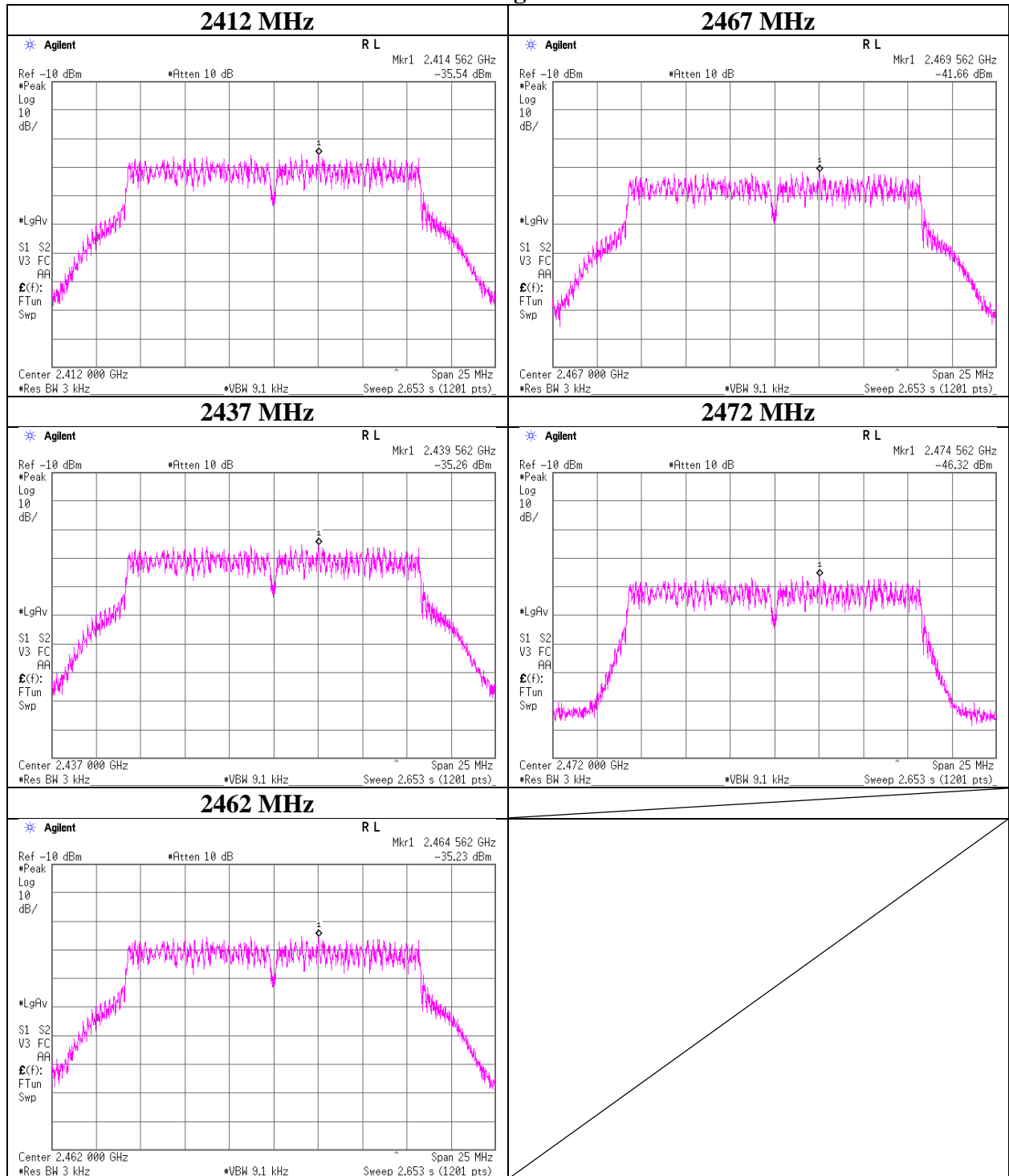

Power Density

11n-20, SISO

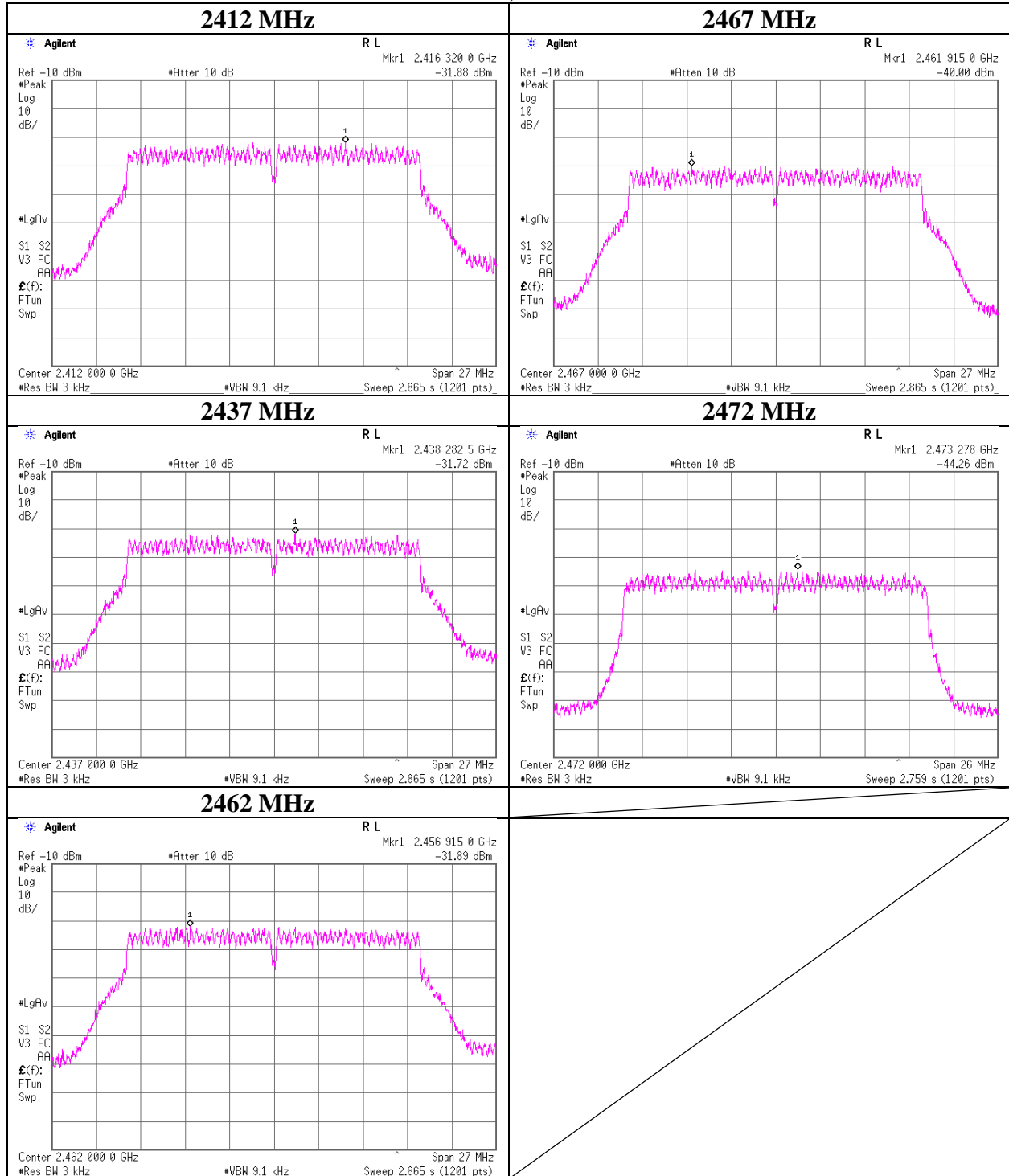

UL Japan, Inc.

Shonan EMC Lab.

1-22-3 Megumigaoka, Hiratsuka-shi, Kanagawa-ken, 259-1220 JAPAN

Telephone : +81 463 50 6400

Facsimile : +81 463 50 6401

Power Density
OFDM VHT20, SISO

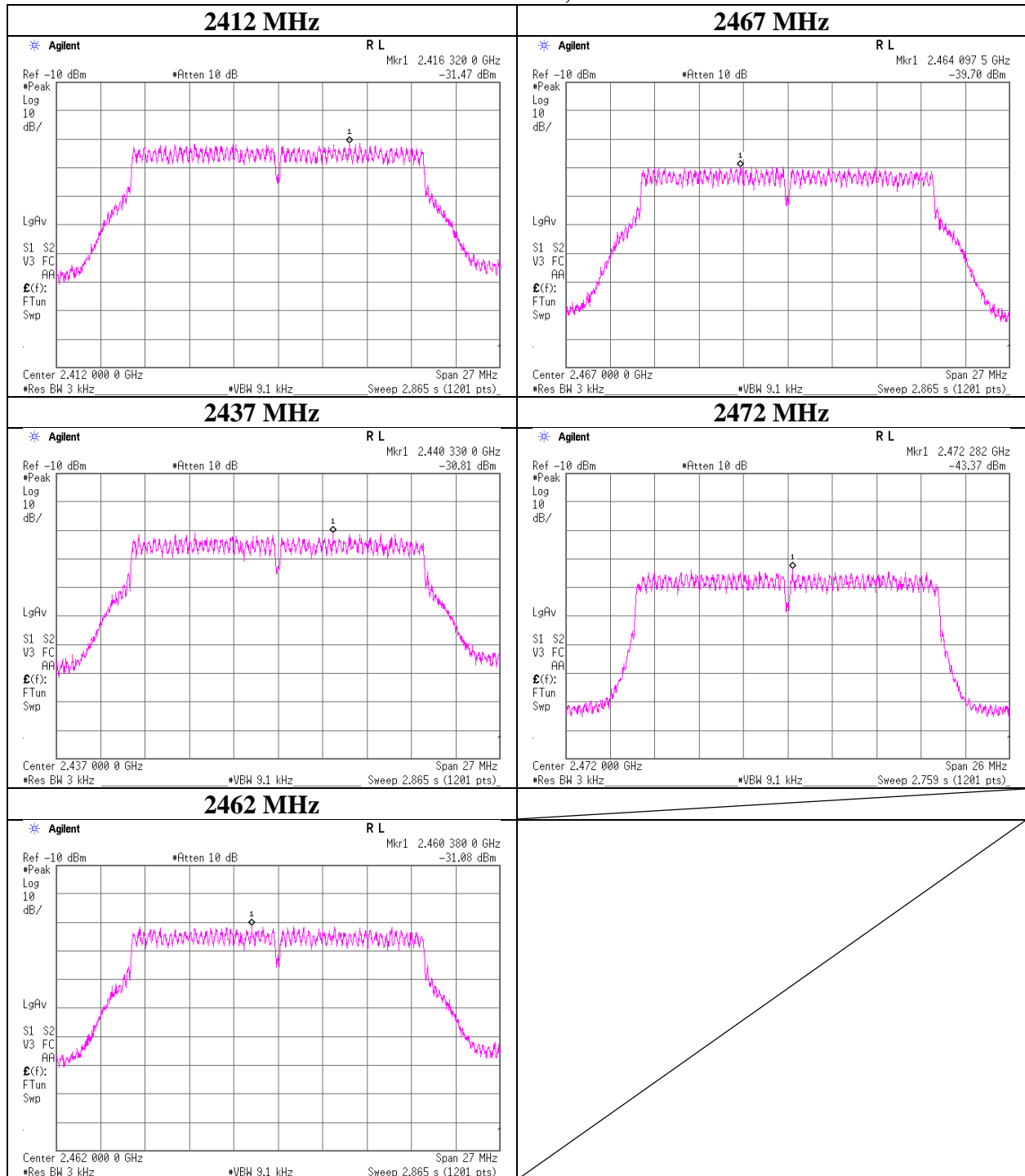

Power Density

11n-40, SISO

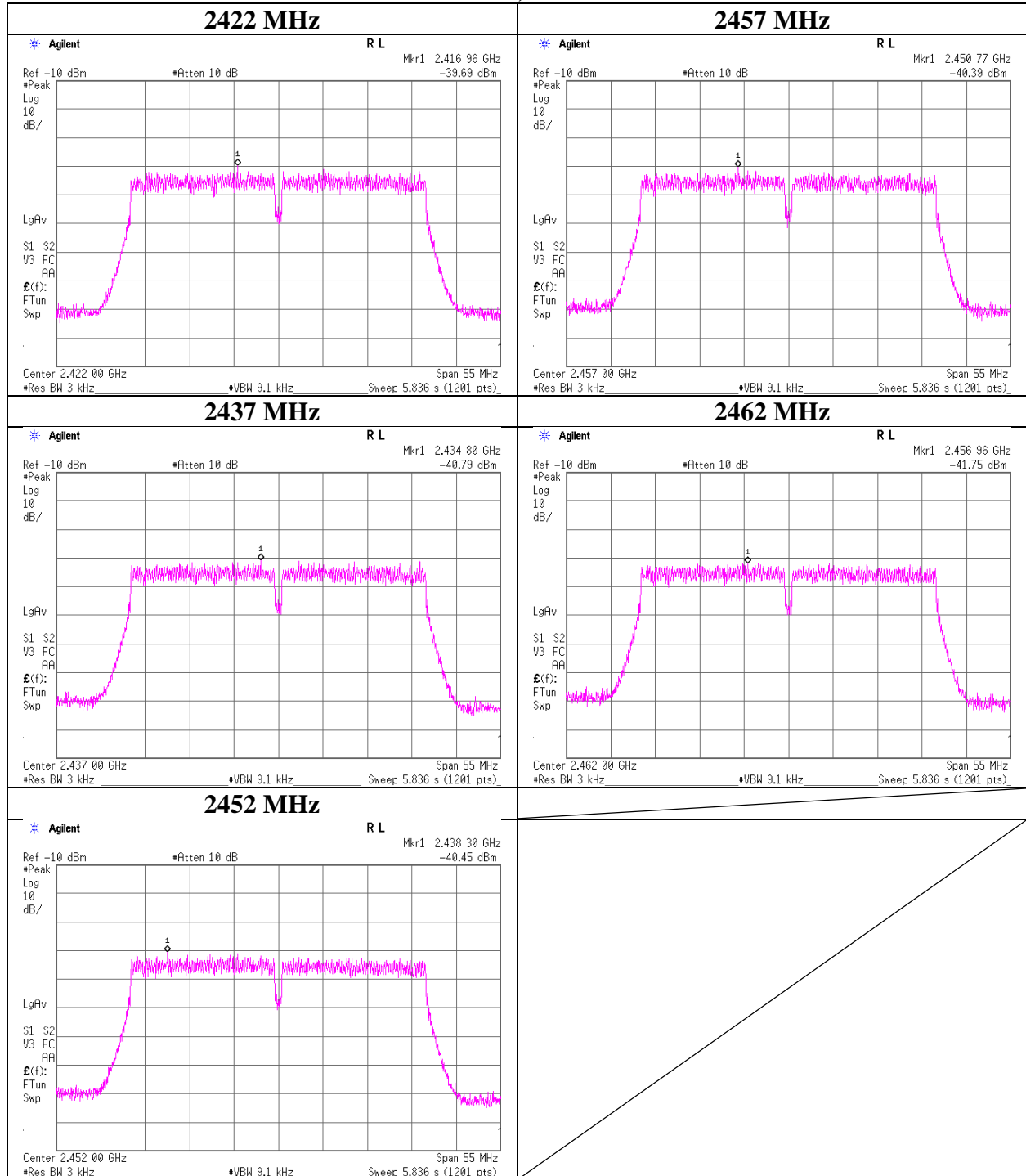

UL Japan, Inc.

Shonan EMC Lab.

1-22-3 Megumigaoka, Hiratsuka-shi, Kanagawa-ken, 259-1220 JAPAN

Telephone : +81 463 50 6400

Facsimile : +81 463 50 6401

Power Density
OFDM VHT40, SISO

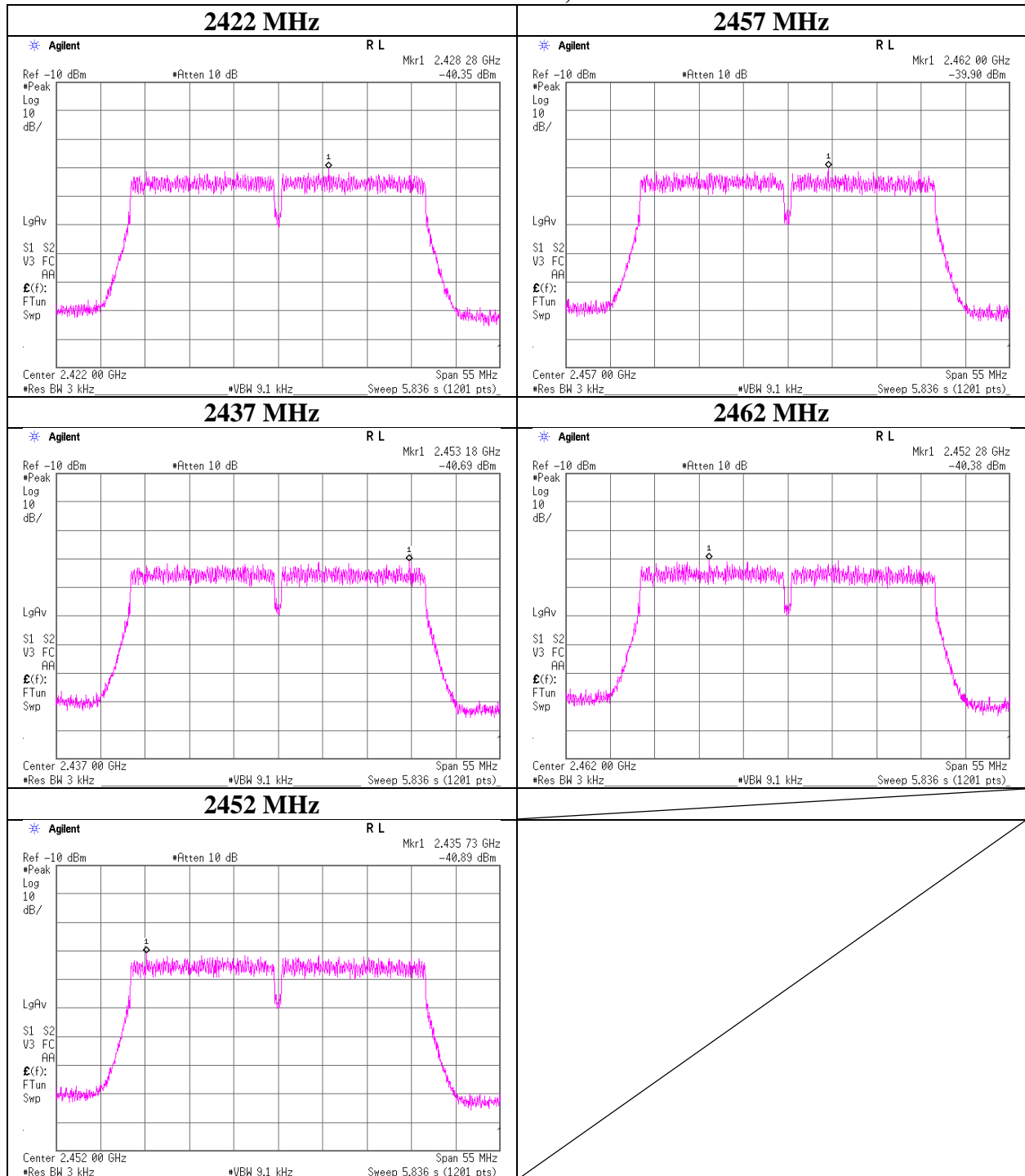

Power Density

Test place Shonan EMC Lab. No.1 Measurement Room
Report No. 11334871S-A-R1
Date November 4, 2016
Temperature / Humidity 24 deg. C / 40 % RH
Engineer Kenichi Adachi
Mode Tx 11n-20, MIMO

Antenna: 0 + 1

Freq. [MHz]	Antenna: 0	Antenna: 1	Result		Limit [dBm]	Margin [dB]
	Result [mW]	Result [mW]	[dBm]	[mW]		
2412.00	0.047	0.038	-10.69	0.085	8.00	18.69
2437.00	0.054	0.045	-10.06	0.099	8.00	18.06
2462.00	0.038	0.047	-10.68	0.086	8.00	18.68
2467.00	0.013	0.009	-16.64	0.022	8.00	24.64
2472.00	0.003	0.002	-22.76	0.005	8.00	30.76

Sample Calculation:

Result [mW] = Antenna: 0 Result [mW] + Antenna: 1 Result [mW]

Antenna: 0

Freq. [MHz]	Frequency Reading [MHz]	Reading [dBm]	Cable Loss [dB]	Atten. Loss [dB]	Result		Limit [dBm]	Margin [dB]
					[dBm]	[mW]		
2412.00	2415.78	-34.90	1.43	20.22	-13.25	0.047	8.00	21.25
2437.00	2436.33	-34.35	1.44	20.23	-12.68	0.054	8.00	20.68
2462.00	2459.17	-35.82	1.44	20.23	-14.15	0.038	8.00	22.15
2467.00	2463.27	-40.65	1.44	20.23	-18.98	0.013	8.00	26.98
2472.00	2468.88	-46.40	1.44	20.23	-24.73	0.003	8.00	32.73

Antenna: 1

Freq. [MHz]	Frequency Reading [MHz]	Reading [dBm]	Cable Loss [dB]	Atten. Loss [dB]	Result		Limit [dBm]	Margin [dB]
					[dBm]	[mW]		
2412.00	2414.48	-35.78	1.36	20.22	-14.20	0.038	8.00	22.20
2437.00	2435.72	-35.09	1.37	20.23	-13.49	0.045	8.00	21.49
2462.00	2459.48	-34.87	1.37	20.23	-13.27	0.047	8.00	21.27
2467.00	2469.50	-42.05	1.37	20.23	-20.45	0.009	8.00	28.45
2472.00	2476.03	-48.76	1.37	20.23	-27.16	0.002	8.00	35.16

Sample Calculation:

Result = Reading + Cable Loss (including the cable(s) customer supplied) + Atten. Loss

*The equipment and cables were not used for factor 0 dB of the data sheets.

*) This test was measured based on Method In-Band Power Spectral Density (PSD) Measurements 2) b)
"Emissions Testing of Transmitters with Multiple Outputs in the Same Band (KDB662911 D1)"

Power Density

11n-20, MIMO, Antenna: 0

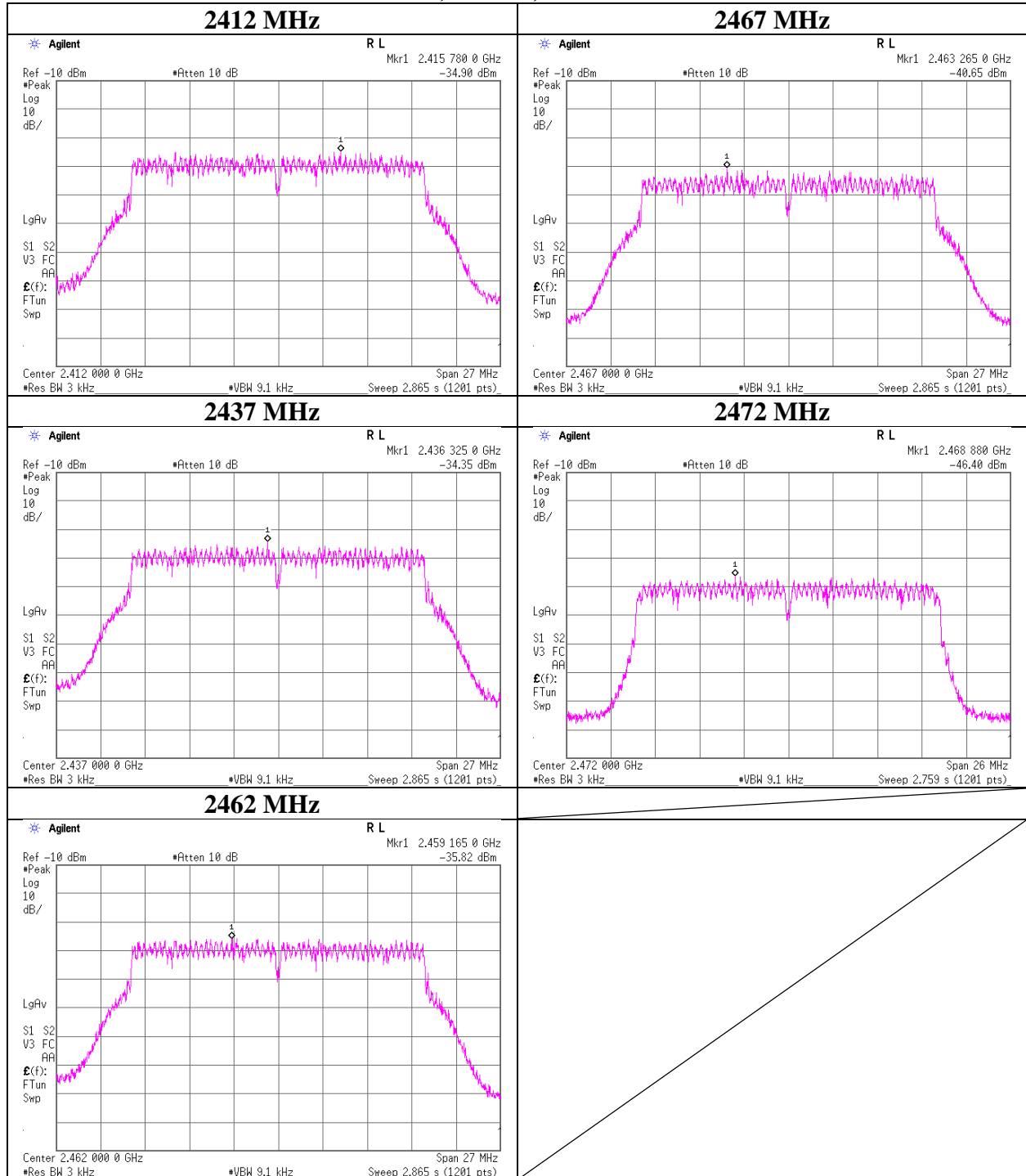

Power Density

11n-20, MIMO, Antenna: 1

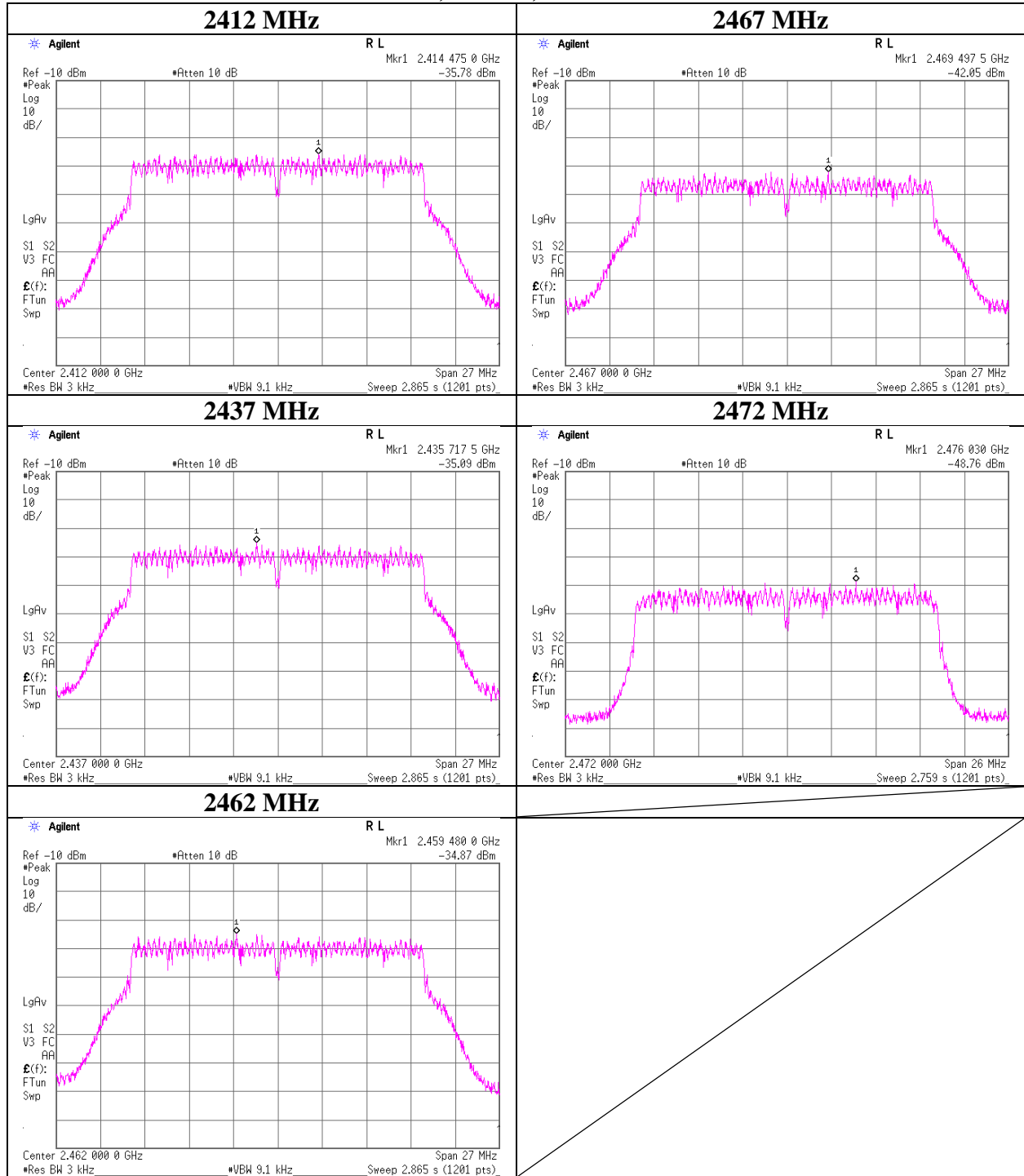

Power Density

Test place : Shonan EMC Lab. No.1 Measurement Room
Report No. : 11334871S-A-R1
Date : November 4, 2016
Temperature / Humidity : 24 deg. C / 40 % RH
Engineer : Kenichi Adachi
Mode : Tx OFDM, VHT20, MIMO

Antenna: 0 + 1

Freq. [MHz]	Antenna: 0	Antenna: 1	Result		Limit [dBm]	Margin [dB]
	Result [mW]	Result [mW]	[dBm]	[mW]		
2412.00	0.048	0.046	-10.30	0.093	8.00	18.30
2437.00	0.049	0.045	-10.29	0.094	8.00	18.29
2462.00	0.051	0.043	-10.27	0.094	8.00	18.27
2467.00	0.010	0.006	-18.01	0.016	8.00	26.01
2472.00	0.003	0.003	-21.78	0.007	8.00	29.78

Sample Calculation:

Result [mW] = Antenna: 0 Result [mW] + Antenna: 1 Result [mW]

Antenna: 0

Freq. [MHz]	Frequency Reading [MHz]	Reading [dBm]	Cable Loss [dB]	Atten. Loss [dB]	Result		Limit [dBm]	Margin [dB]
					[dBm]	[mW]		
2412.00	2409.17	-34.87	1.43	20.22	-13.22	0.048	8.00	21.22
2437.00	2433.51	-34.78	1.44	20.23	-13.11	0.049	8.00	21.11
2462.00	2458.20	-34.56	1.44	20.23	-12.89	0.051	8.00	20.89
2467.00	2461.96	-41.76	1.44	20.23	-20.09	0.010	8.00	28.09
2472.00	2474.49	-46.36	1.44	20.23	-24.69	0.003	8.00	32.69

Antenna: 1

Freq. [MHz]	Frequency Reading [MHz]	Reading [dBm]	Cable Loss [dB]	Atten. Loss [dB]	Result		Limit [dBm]	Margin [dB]
					[dBm]	[mW]		
2412.00	2406.98	-34.99	1.36	20.22	-13.41	0.046	8.00	21.41
2437.00	2437.61	-35.09	1.37	20.23	-13.49	0.045	8.00	21.49
2462.00	2456.04	-35.32	1.37	20.23	-13.72	0.043	8.00	21.72
2467.00	2469.48	-43.81	1.37	20.23	-22.21	0.006	8.00	30.21
2472.00	2465.72	-46.50	1.37	20.23	-24.90	0.003	8.00	32.90

Sample Calculation:

Result = Reading + Cable Loss (including the cable(s) customer supplied) + Atten. Loss

*The equipment and cables were not used for factor 0 dB of the data sheets.

*) This test was measured based on Method In-Band Power Spectral Density (PSD) Measurements 2) b) "Emissions Testing of Transmitters with Multiple Outputs in the Same Band (KDB662911 D1)"

Power Density

OFDM VHT20, MIMO, Antenna: 0

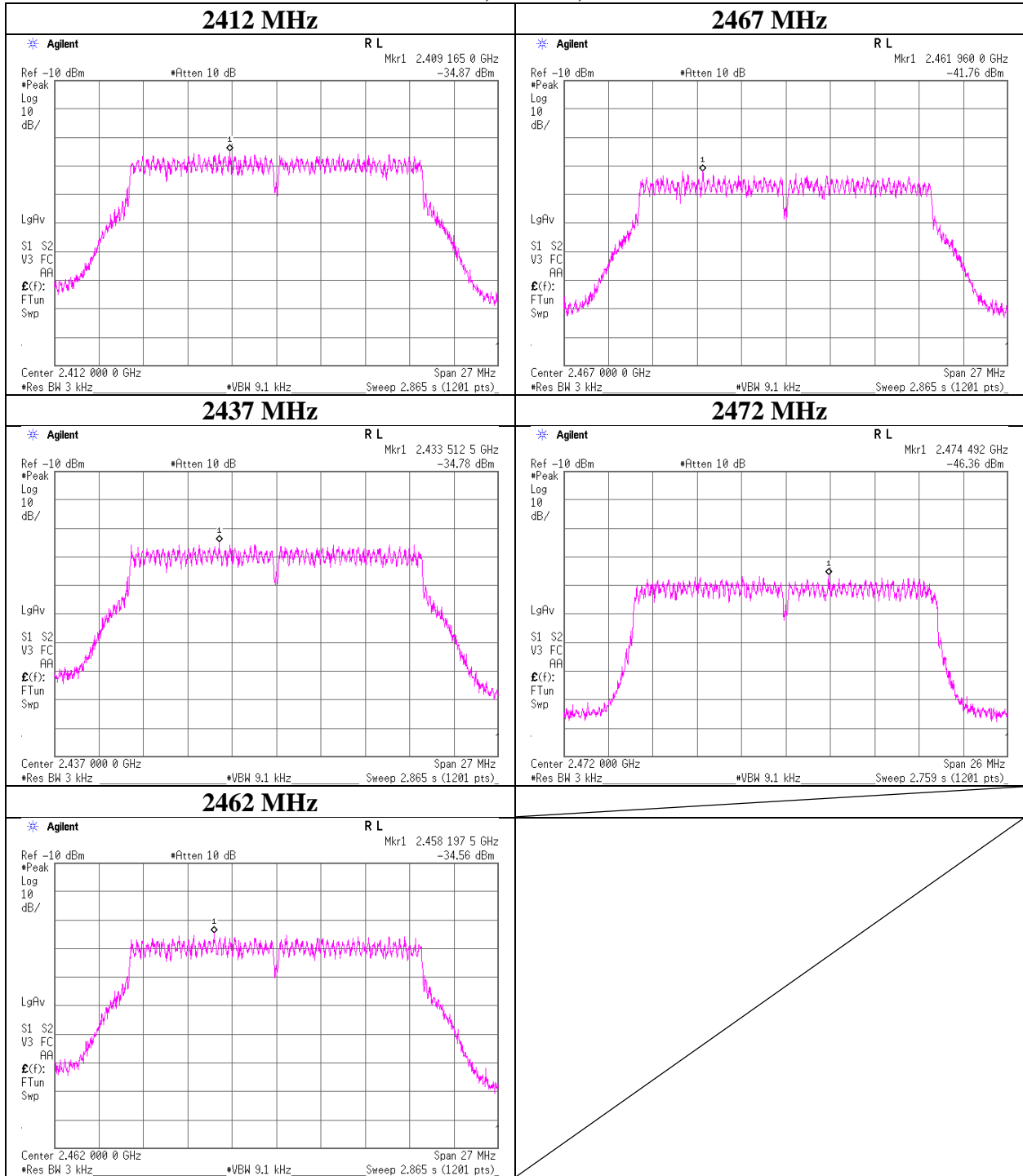

UL Japan, Inc.

Shonan EMC Lab.

1-22-3 Megumigaoka, Hiratsuka-shi, Kanagawa-ken, 259-1220 JAPAN

Telephone : +81 463 50 6400

Facsimile : +81 463 50 6401

Power Density

OFDM VHT20, MIMO, Antenna: 1

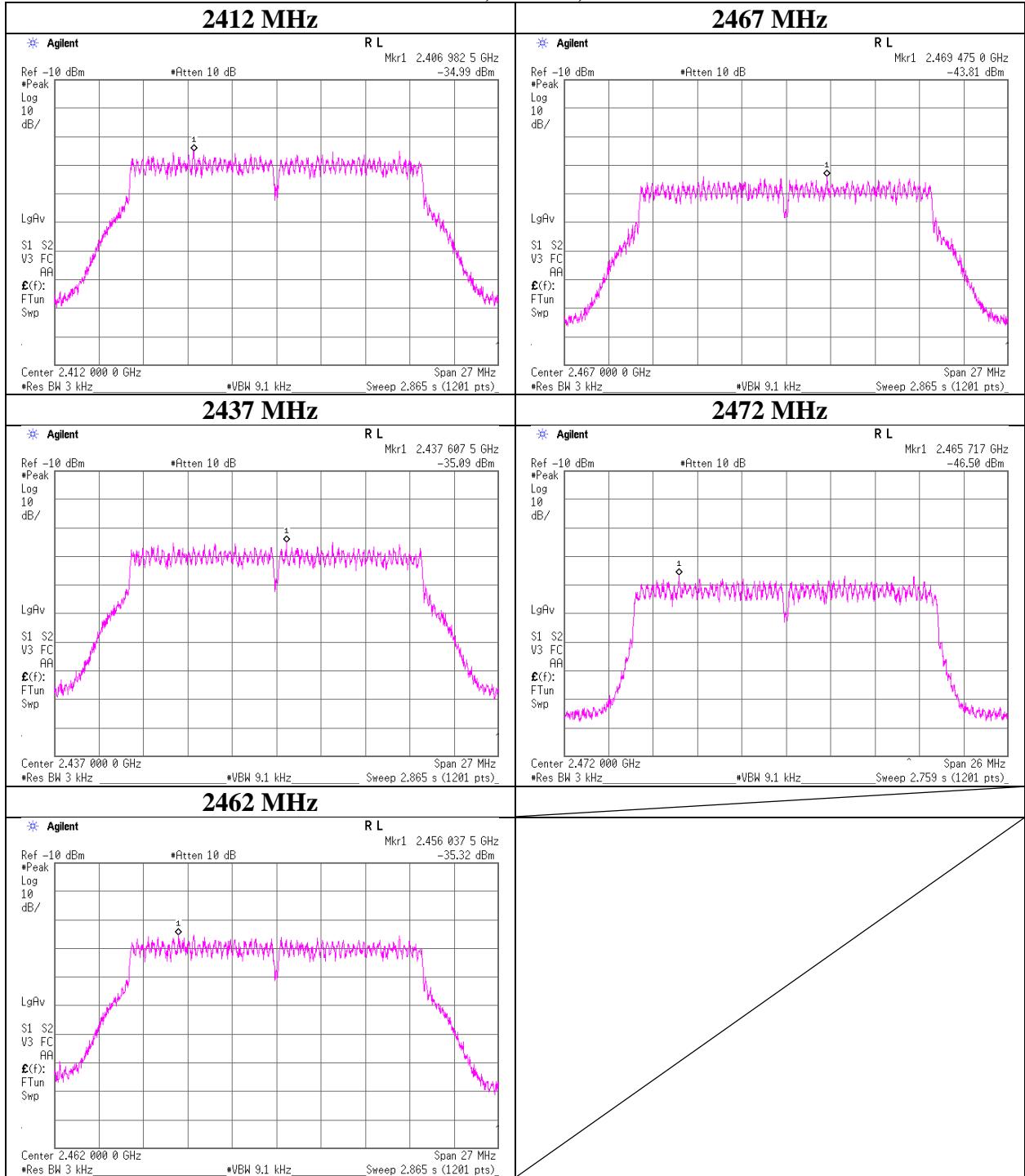

Power Density

Test place : Shonan EMC Lab. No.1 Measurement Room
Report No. : 11334871S-A-R1
Date : November 4, 2016
Temperature / Humidity : 24 deg. C / 40 % RH
Engineer : Kenichi Adachi
Mode : Tx 11n-40, MIMO

Antenna: 0 + 1

Freq. [MHz]	Antenna: 0	Antenna: 1	Result		Limit [dBm]	Margin [dB]
	Result [mW]	Result [mW]	[dBm]	[mW]		
2422.00	0.009	0.008	-17.87	0.016	8.00	25.87
2437.00	0.009	0.008	-17.75	0.017	8.00	25.75
2452.00	0.008	0.007	-18.13	0.015	8.00	26.13
2457.00	0.008	0.008	-17.94	0.016	8.00	25.94
2462.00	0.005	0.004	-20.38	0.009	8.00	28.38

Sample Calculation:

Result [mW] = Antenna: 0 Result [mW] + Antenna: 1 Result [mW]

Antenna: 0

Freq. [MHz]	Frequency Reading [MHz]	Reading [dBm]	Cable Loss [dB]	Atten. Loss [dB]	Result		Limit [dBm]	Margin [dB]
					[dBm]	[mW]		
2422.00	2434.47	-42.23	1.43	20.23	-20.57	0.009	8.00	28.57
2437.00	2434.48	-42.10	1.44	20.23	-20.43	0.009	8.00	28.43
2452.00	2435.73	-42.61	1.44	20.23	-20.94	0.008	8.00	28.94
2457.00	2462.64	-42.62	1.44	20.23	-20.95	0.008	8.00	28.95
2462.00	2467.64	-44.70	1.44	20.23	-23.03	0.005	8.00	31.03

Antenna: 1

Freq. [MHz]	Frequency Reading [MHz]	Reading [dBm]	Cable Loss [dB]	Atten. Loss [dB]	Result		Limit [dBm]	Margin [dB]
					[dBm]	[mW]		
2422.00	2439.46	-42.81	1.36	20.23	-21.22	0.008	8.00	29.22
2437.00	2425.72	-42.71	1.37	20.23	-21.11	0.008	8.00	29.11
2452.00	2443.29	-42.95	1.37	20.23	-21.35	0.007	8.00	29.35
2457.00	2448.29	-42.56	1.37	20.23	-20.96	0.008	8.00	28.96
2462.00	2450.72	-45.39	1.37	20.23	-23.79	0.004	8.00	31.79

Sample Calculation:

Result = Reading + Cable Loss (including the cable(s) customer supplied) + Atten. Loss

*The equipment and cables were not used for factor 0 dB of the data sheets.

*) This test was measured based on Method In-Band Power Spectral Density (PSD) Measurements 2) b)
"Emissions Testing of Transmitters with Multiple Outputs in the Same Band (KDB662911 D1)"

Power Density

11n40, MIMO, Antenna: 0

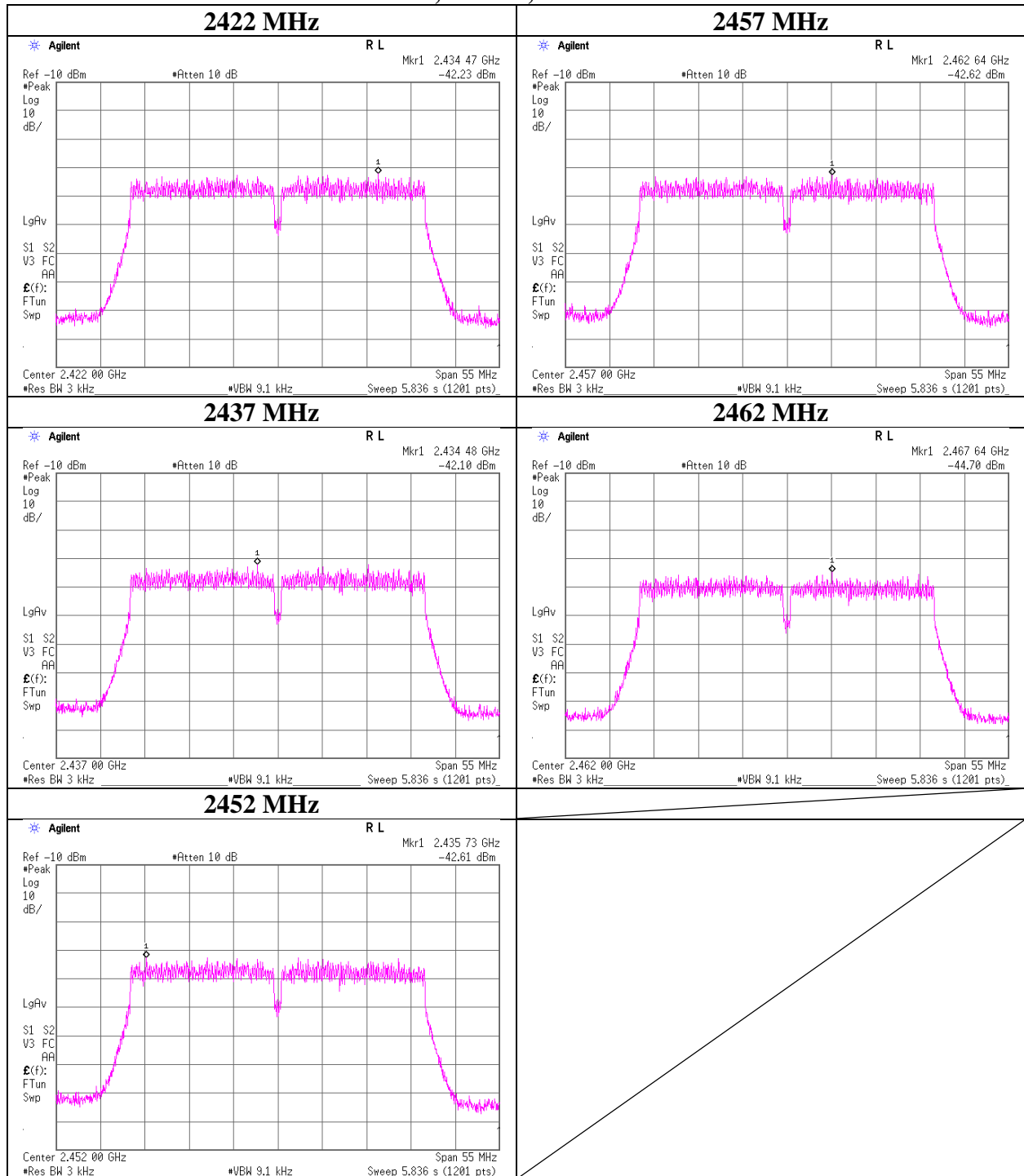

Power Density

11n40, MIMO, Antenna: 1

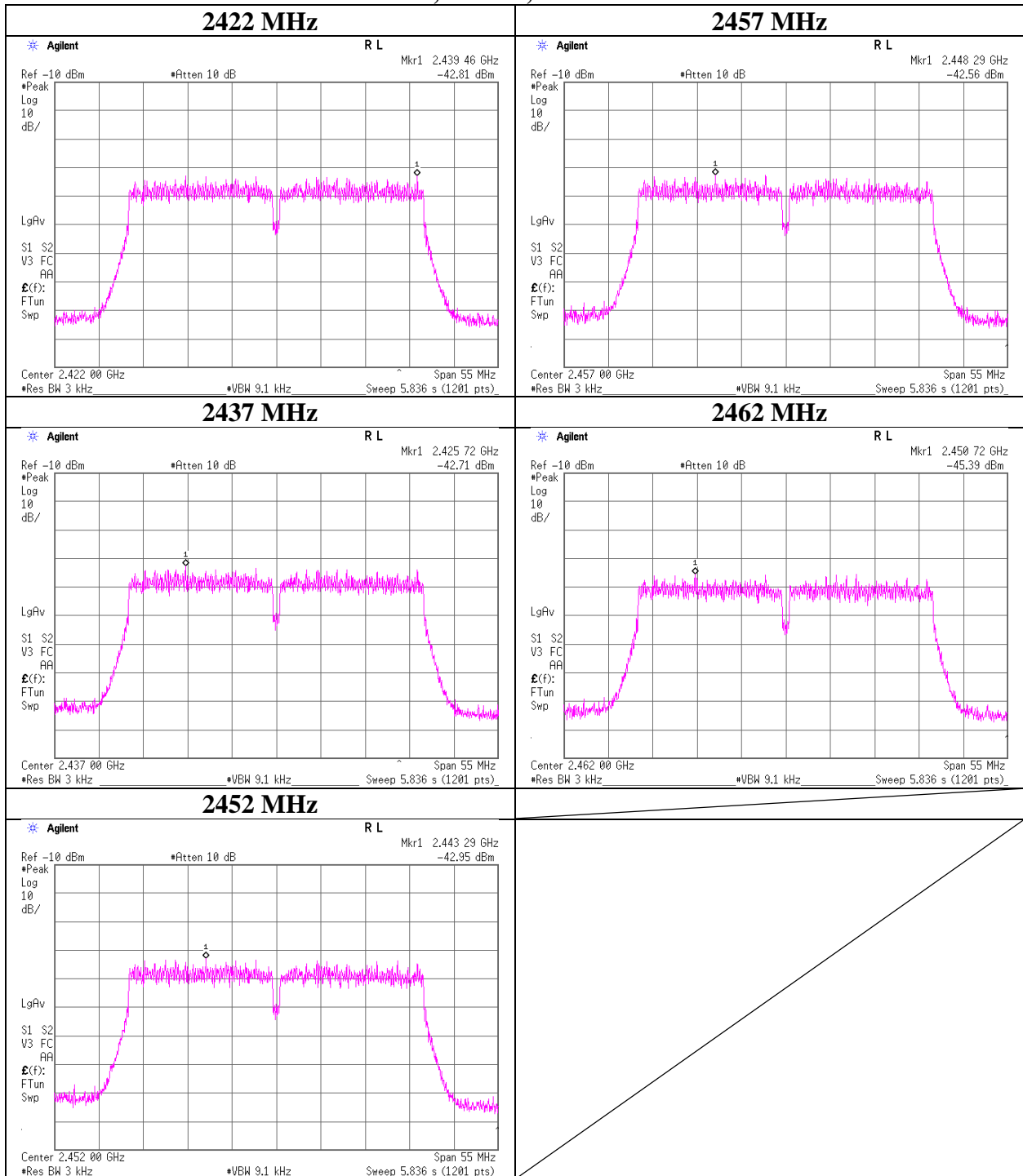

Power Density

Test place : Shonan EMC Lab. No.1 Measurement Room
Report No. : 11334871S-A-R1
Date : November 4, 2016
Temperature / Humidity : 24 deg. C / 40 % RH
Engineer : Kenichi Adachi
Mode : Tx OFDM, VHT40, MIMO

Antenna: 0 + 1

Freq. [MHz]	Antenna: 0	Antenna: 1	Result		Limit [dBm]	Margin [dB]
	Result [mW]	Result [mW]	[dBm]	[mW]		
2422.00	0.010	0.008	-17.51	0.018	8.00	25.51
2437.00	0.011	0.007	-17.56	0.018	8.00	25.56
2452.00	0.008	0.008	-18.15	0.015	8.00	26.15
2457.00	0.008	0.008	-17.78	0.017	8.00	25.78
2462.00	0.004	0.004	-20.69	0.009	8.00	28.69

Sample Calculation:

Result [mW] = Antenna: 0 Result [mW] + Antenna: 1 Result [mW]

Antenna: 0

Freq. [MHz]	Frequency Reading [MHz]	Reading [dBm]	Cable Loss [dB]	Atten. Loss [dB]	Result		Limit [dBm]	Margin [dB]
					[dBm]	[mW]		
2422.00	2427.64	-41.65	1.43	20.23	-19.99	0.010	8.00	27.99
2437.00	2434.48	-41.42	1.44	20.23	-19.75	0.011	8.00	27.75
2452.00	2469.46	-42.76	1.44	20.23	-21.09	0.008	8.00	29.09
2457.00	2463.55	-42.38	1.44	20.23	-20.71	0.008	8.00	28.71
2462.00	2453.25	-45.48	1.44	20.23	-23.81	0.004	8.00	31.81

Antenna: 1

Freq. [MHz]	Frequency Reading [MHz]	Reading [dBm]	Cable Loss [dB]	Atten. Loss [dB]	Result		Limit [dBm]	Margin [dB]
					[dBm]	[mW]		
2422.00	2419.48	-42.72	1.36	20.23	-21.13	0.008	8.00	29.13
2437.00	2431.36	-43.19	1.37	20.23	-21.59	0.007	8.00	29.59
2452.00	2458.55	-42.83	1.37	20.23	-21.23	0.008	8.00	29.23
2457.00	2454.48	-42.48	1.37	20.23	-20.88	0.008	8.00	28.88
2462.00	2446.97	-45.19	1.37	20.23	-23.59	0.004	8.00	31.59

Sample Calculation:

Result = Reading + Cable Loss (including the cable(s) customer supplied) + Atten. Loss

*The equipment and cables were not used for factor 0 dB of the data sheets.

*) This test was measured based on Method In-Band Power Spectral Density (PSD) Measurements 2) b) "Emissions Testing of Transmitters with Multiple Outputs in the Same Band (KDB662911 D1)"

Power Density

OFDM VHT40, MIMO, Antenna: 0

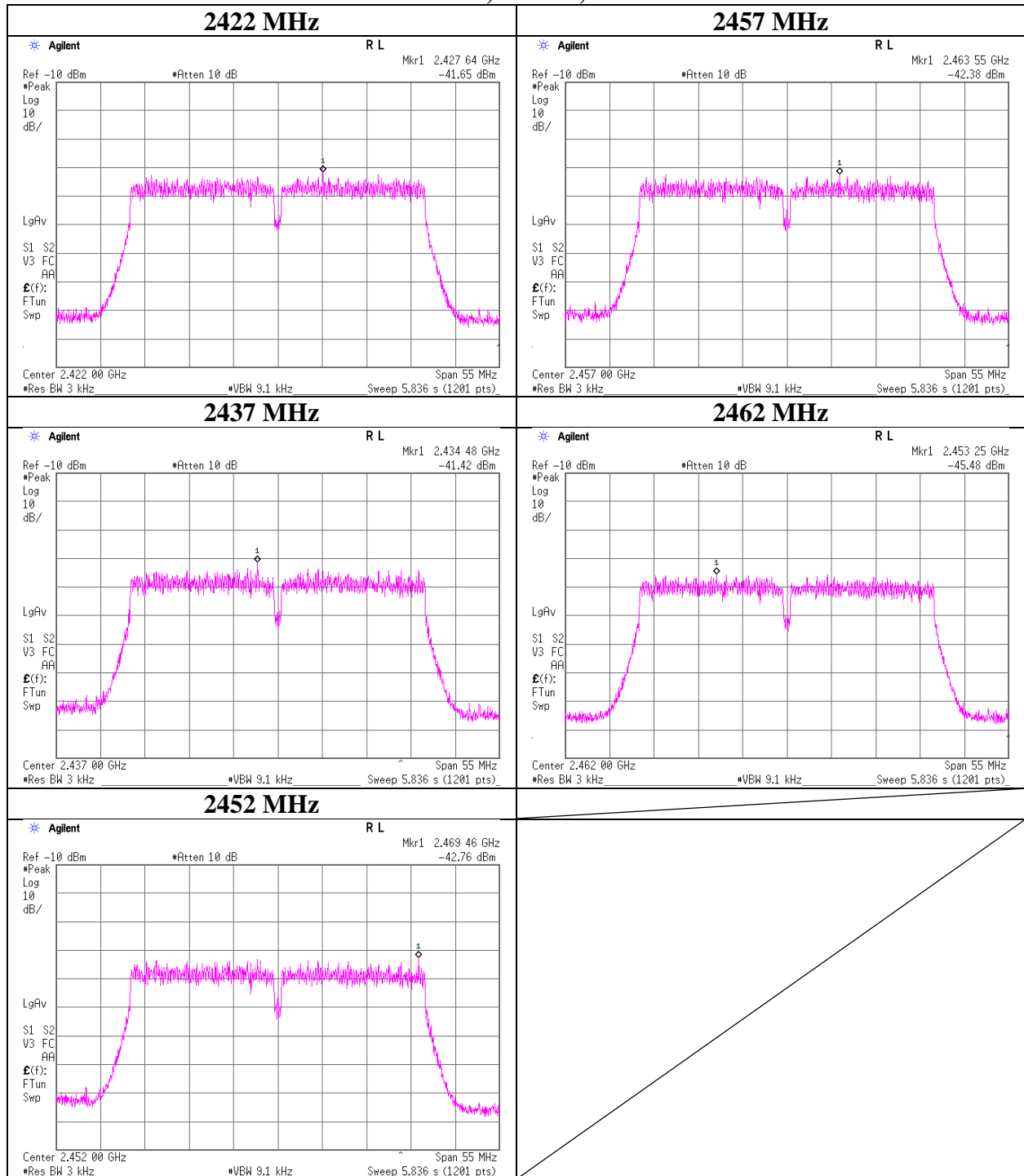

UL Japan, Inc.

Shonan EMC Lab.

1-22-3 Megumigaoka, Hiratsuka-shi, Kanagawa-ken, 259-1220 JAPAN

Telephone : +81 463 50 6400

Facsimile : +81 463 50 6401

Power Density

OFDM VHT40, MIMO, Antenna: 1

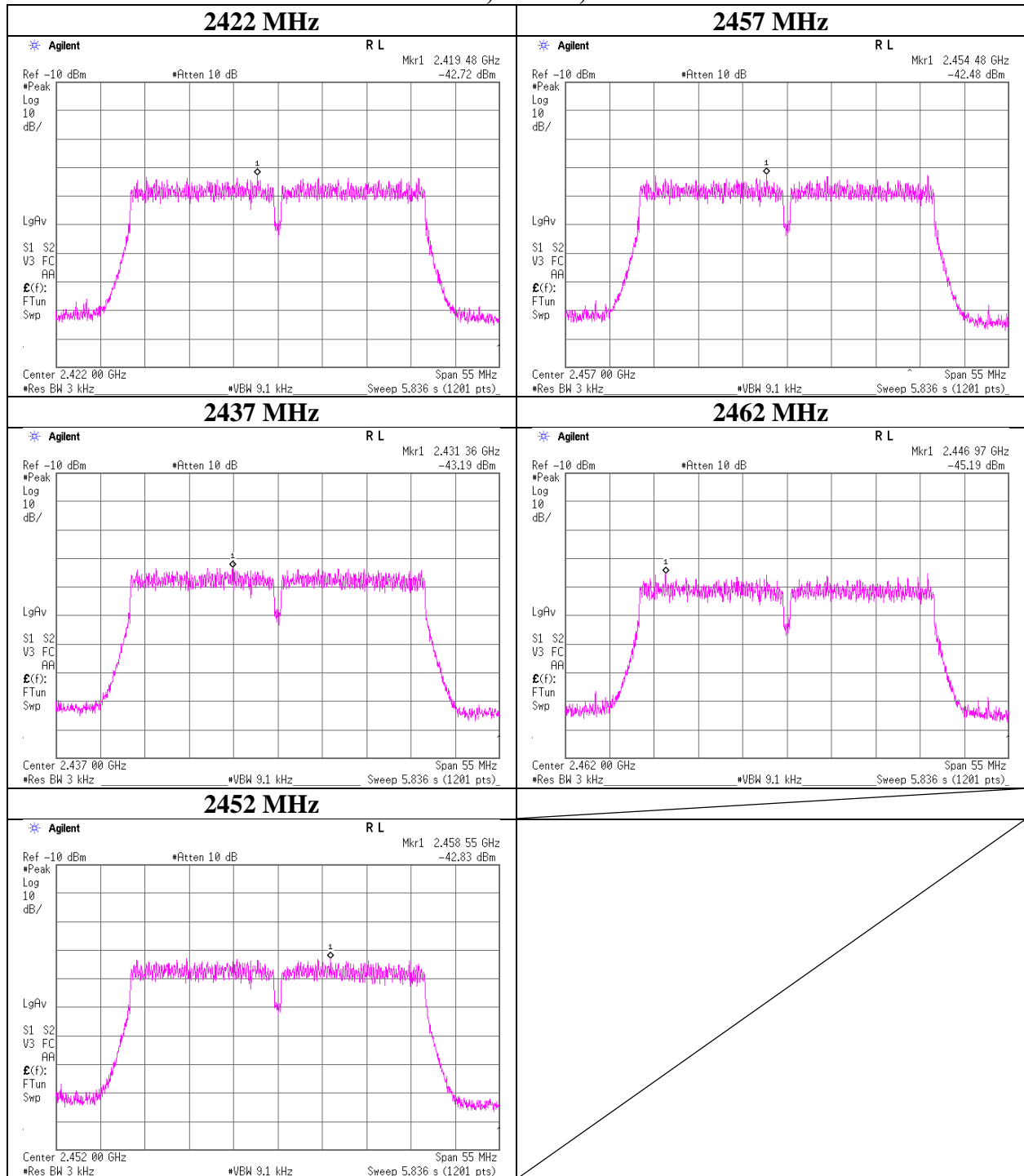

Power Density

Test place	Shonan EMC Lab. No.1 Measurement Room
Report No.	11334871S-A-R1
Date	November 11, 2016
Temperature / Humidity	25 deg. C / 33 % RH
Engineer	Hikaru Shirasawa
Mode	Tx BT LE

Freq. [MHz]	Frequency Reading [MHz]	Reading [dBm]	Cable Loss [dB]	Atten. Loss [dB]	Result [dBm]	Limit [dBm]	Margin [dB]
2402.00	2401.97	-23.66	1.43	10.01	-12.22	8.00	20.22
2440.00	2439.96	-23.51	1.44	10.01	-12.06	8.00	20.06
2480.00	2479.96	-23.37	1.45	10.01	-11.91	8.00	19.91

Sample Calculation:

Result = Reading + Cable Loss (including the cable(s) customer supplied) + Attenuator

*The equipment and cables were not used for factor 0 dB of the data sheets.

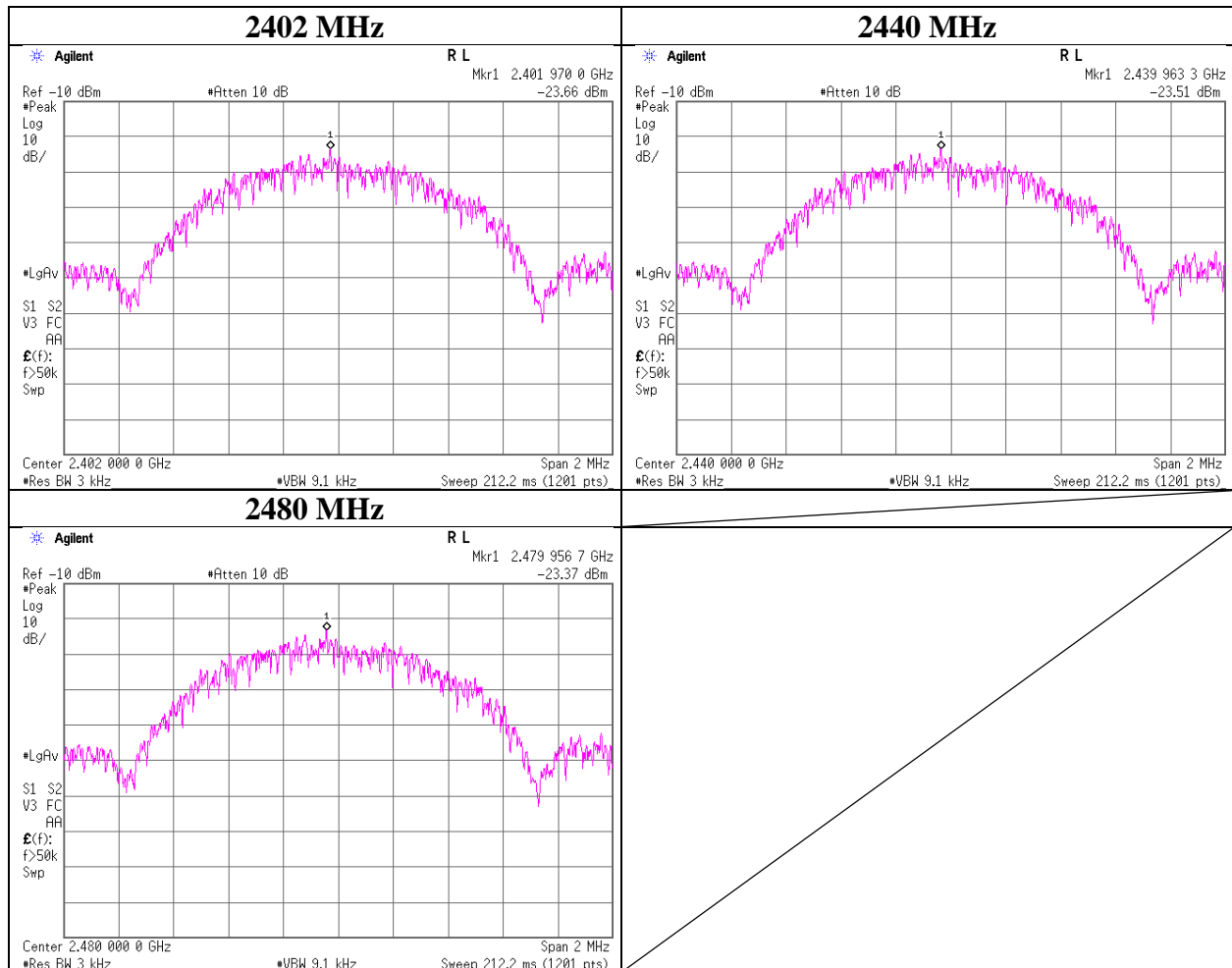

UL Japan, Inc.

Shonan EMC Lab.

1-22-3 Megumigaoka, Hiratsuka-shi, Kanagawa-ken, 259-1220 JAPAN

Telephone : +81 463 50 6400

Facsimile : +81 463 50 6401

99 % Occupied Bandwidth

Test place	Shonan EMC Lab. No.1 Measurement Room
Report No.	11334871S-A-R1
Date	October 21, 2016
Temperature / Humidity	26 deg. C / 45 % RH
Engineer	Kenichi Adachi
Mode	Tx 11b, Antenna: 1 (worst)

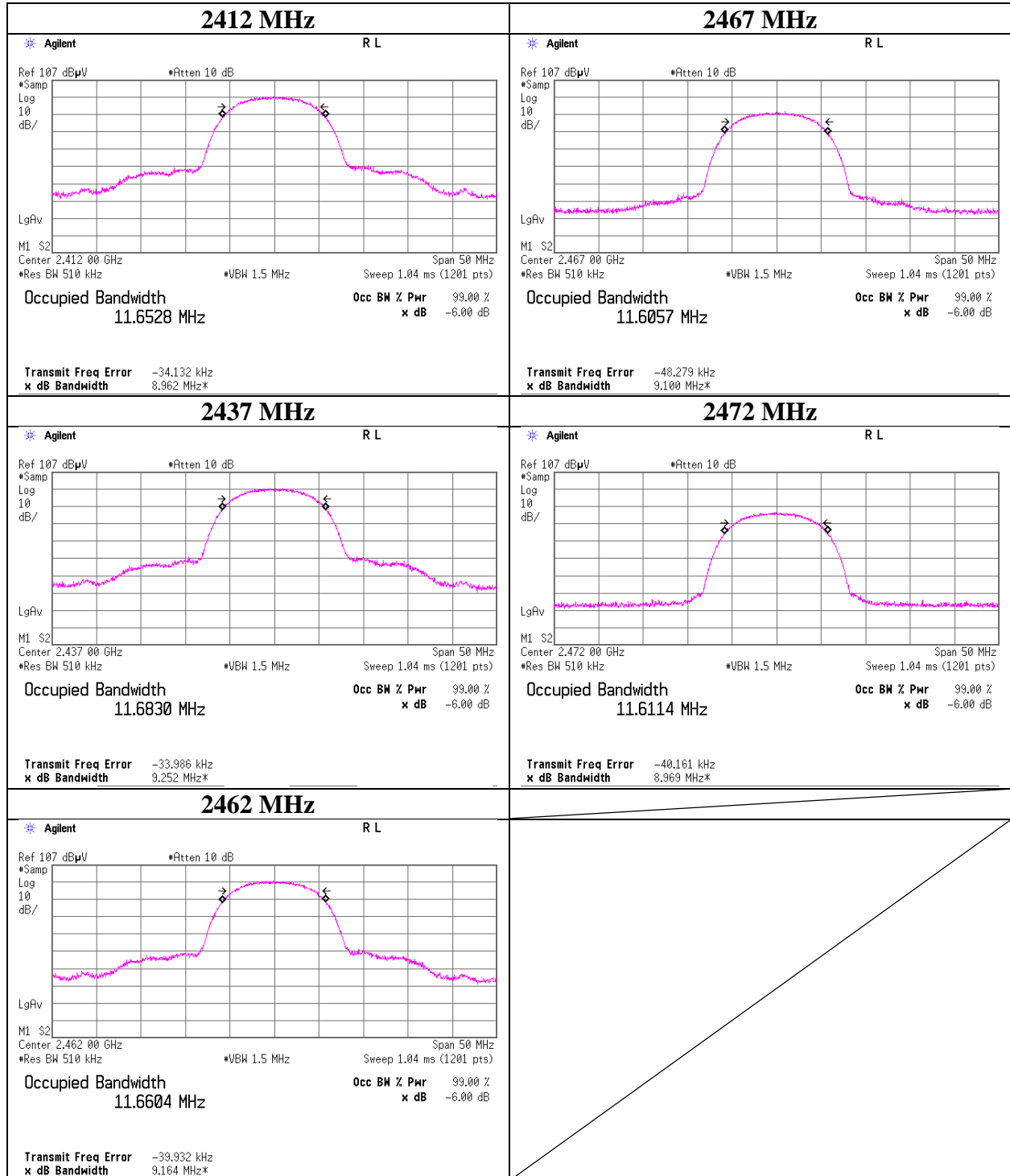

99 % Occupied Bandwidth

Test place	Shonan EMC Lab. No.1 Measurement Room
Report No.	11334871S-A-R1
Date	October 21, 2016
Temperature / Humidity	26 deg. C / 45 % RH
Engineer	Kenichi Adachi
Mode	Tx 11g, Antenna: 0 (worst)

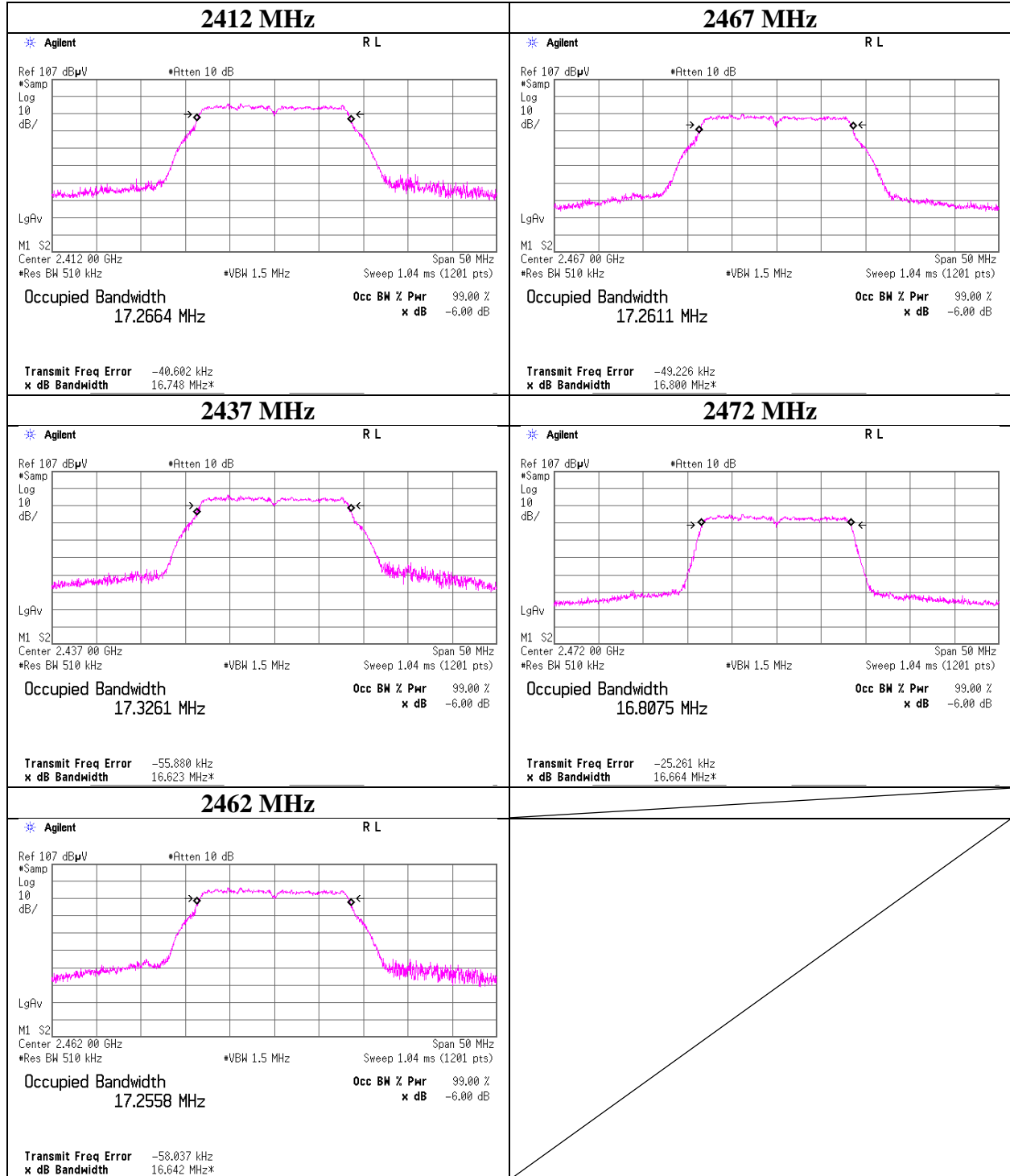

99 % Occupied Bandwidth

Test place	Shonan EMC Lab. No.1 Measurement Room
Report No.	11334871S-A-R1
Date	October 21, 2016
Temperature / Humidity	26 deg. C / 45 % RH
Engineer	Kenichi Adachi
Mode	Tx 11n-20, SISO, Antenna: 1 (worst)

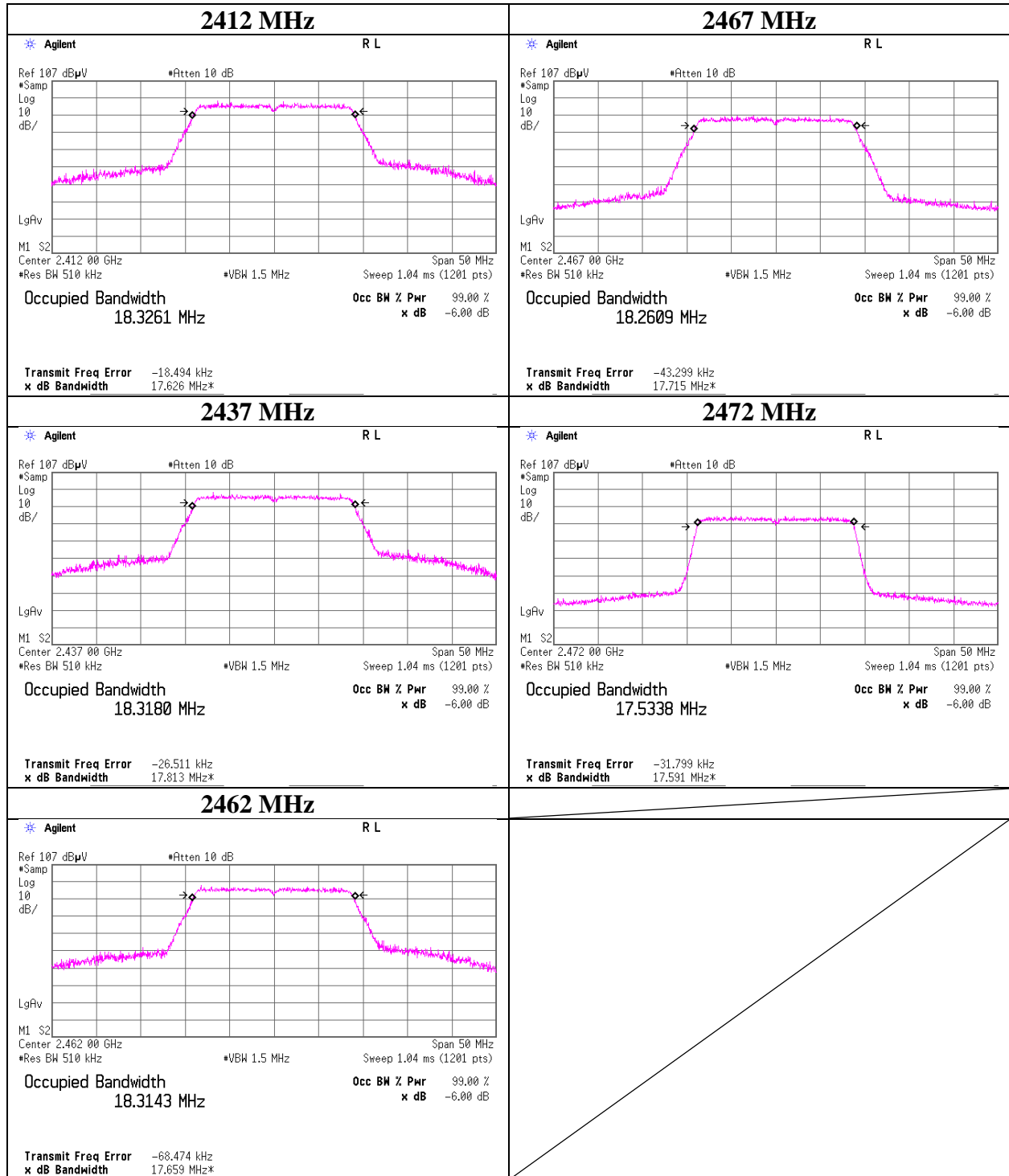

99 % Occupied Bandwidth

Test place	Shonan EMC Lab. No.1 Measurement Room
Report No.	11334871S-A-R1
Date	November 2, 2016
Temperature / Humidity	24 deg. C / 36 % RH
Engineer	Kenichi Adachi
Mode	Tx OFDM, VHT20, SISO, Antenna: 1 (worst)

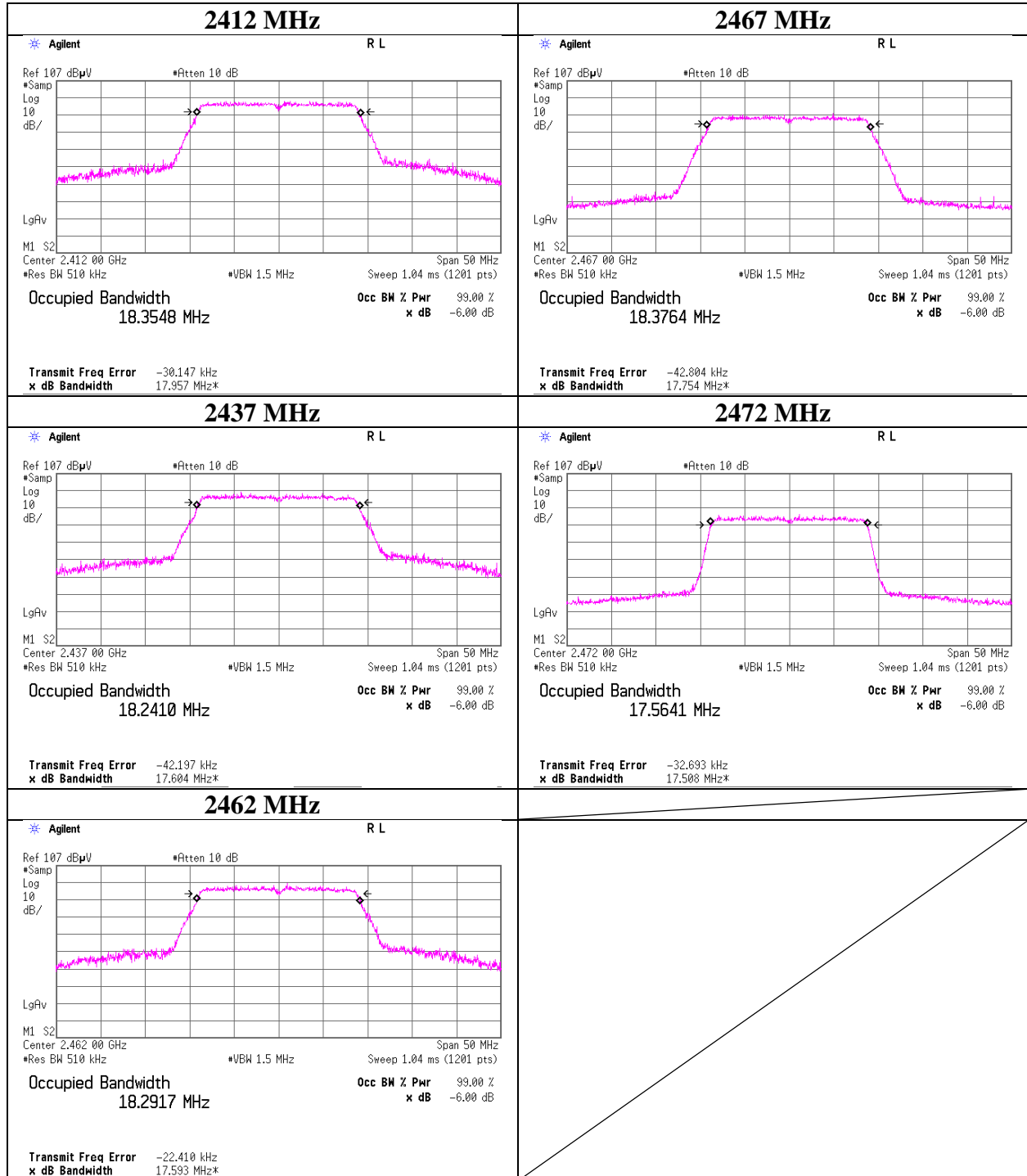

99 % Occupied Bandwidth

Test place	Shonan EMC Lab. No.1 Measurement Room
Report No.	11334871S-A-R1
Date	November 4, 2016
Temperature / Humidity	24 deg. C / 40 % RH
Engineer	Kenichi Adachi
Mode	Tx 11n-40, SISO, Antenna: 0 (worst)

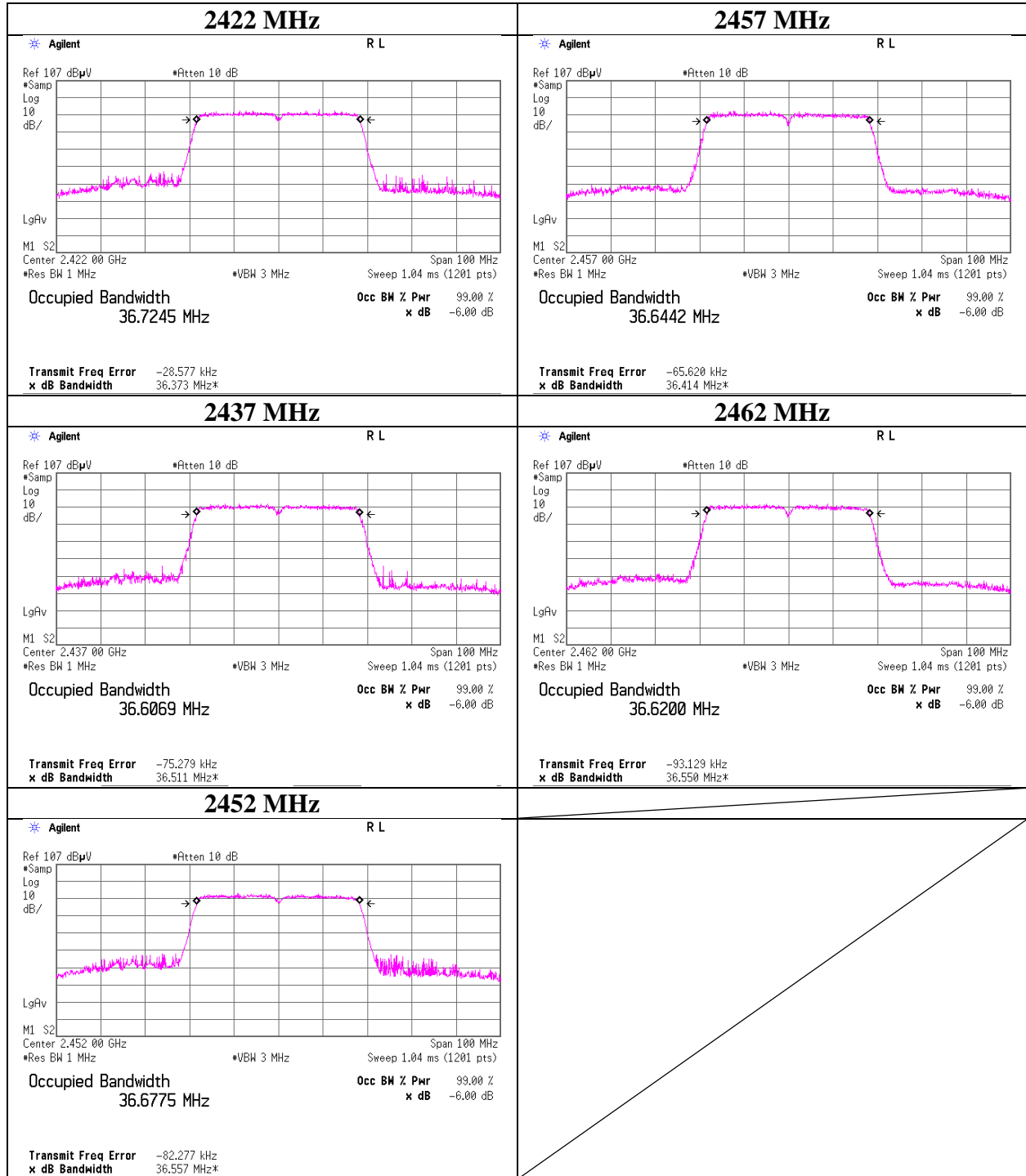

99 % Occupied Bandwidth

Test place	Shonan EMC Lab. No.1 Measurement Room
Report No.	11334871S-A-R1
Date	November 4, 2016
Temperature / Humidity	24 deg. C / 40 % RH
Engineer	Kenichi Adachi
Mode	Tx OFDM, VHT40, SISO, Antenna: 0 (worst)

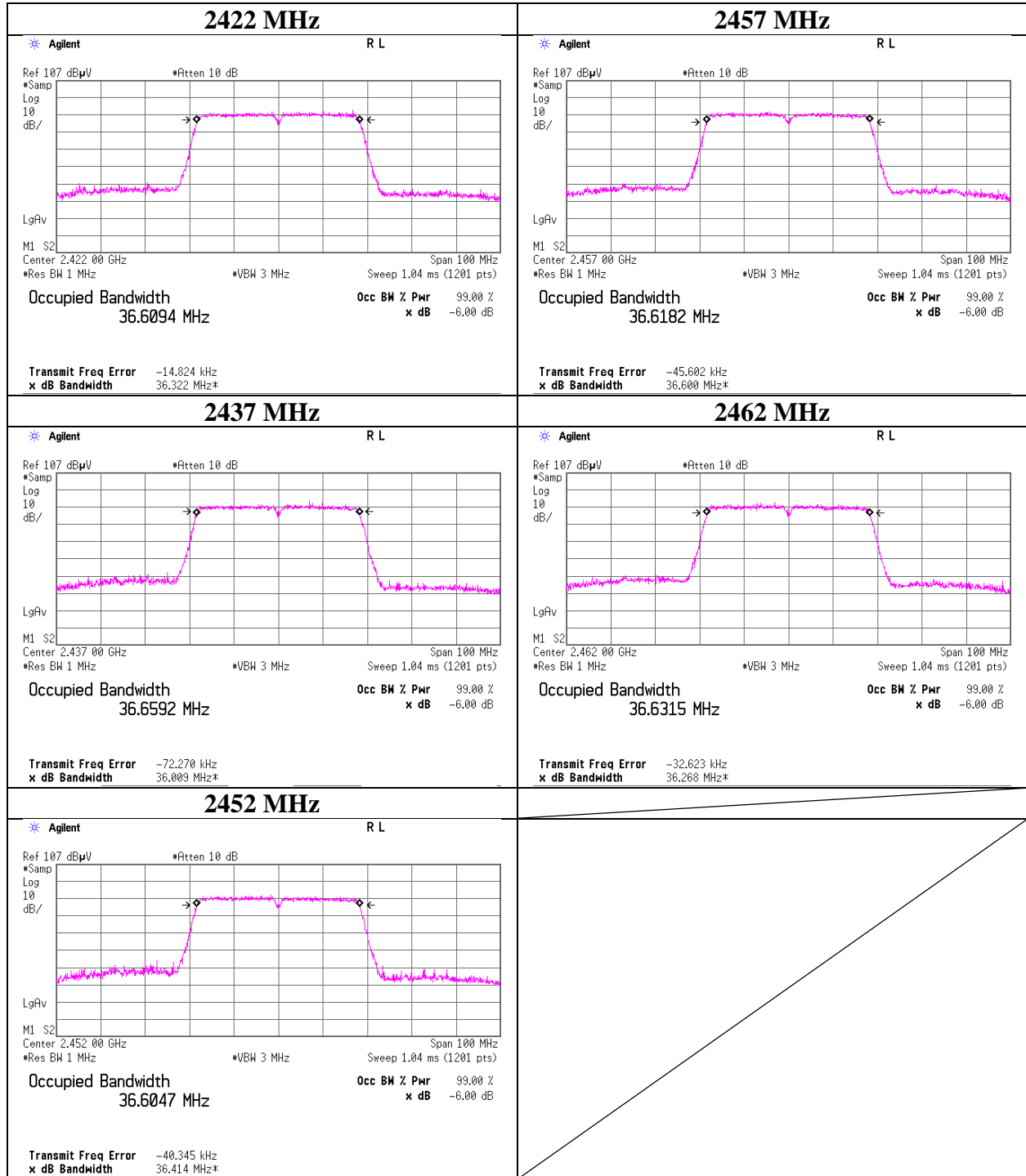

99 % Occupied Bandwidth

Test place	Shonan EMC Lab. No.1 Measurement Room
Report No.	11334871S-A-R1
Date	November 4, 2016
Temperature / Humidity	24 deg. C / 40 % RH
Engineer	Kenichi Adachi
Mode	Tx 11n-20, MIMO, Antenna: 0 (worst)

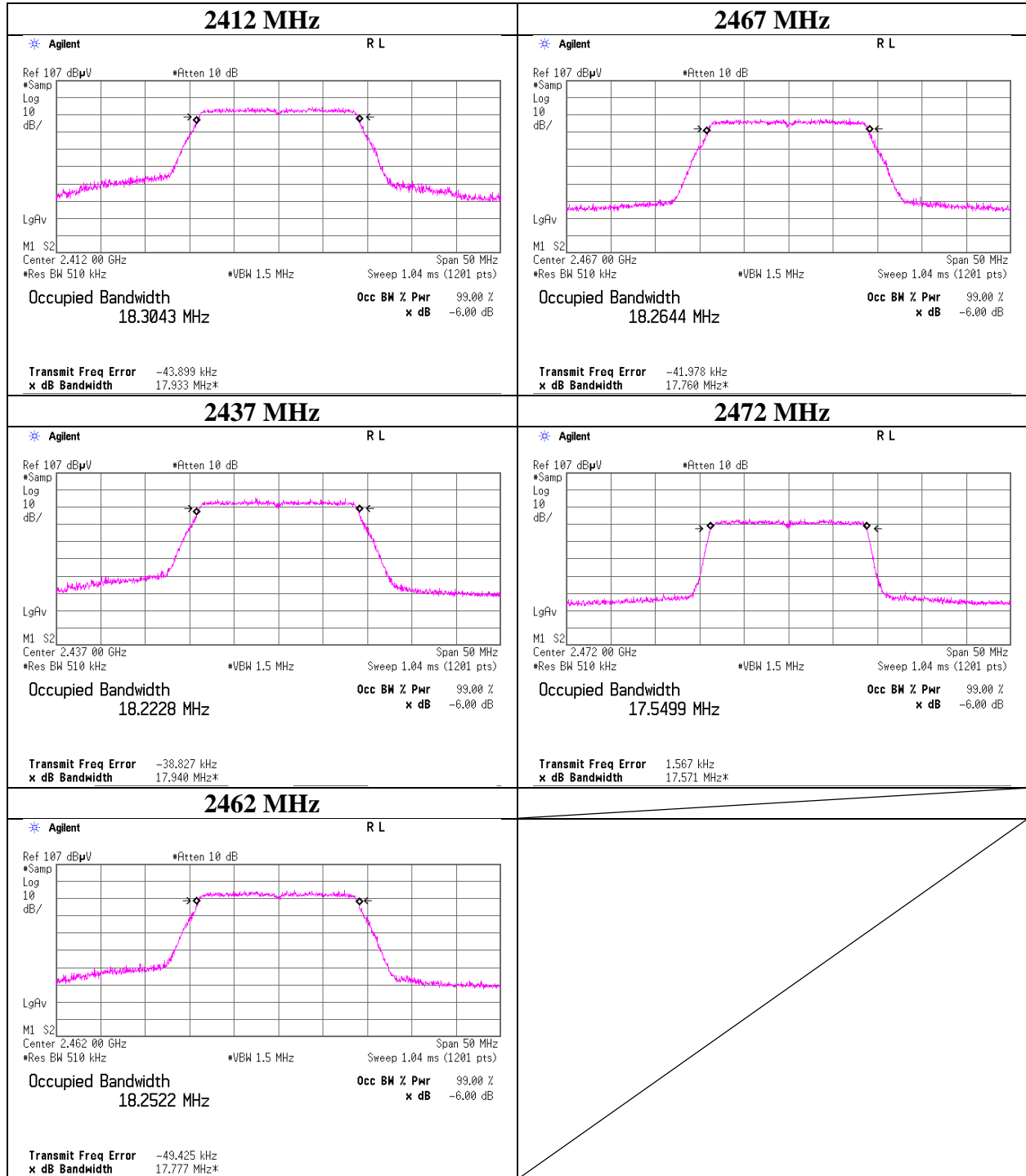

99 % Occupied Bandwidth

Test place	Shonan EMC Lab. No.1 Measurement Room
Report No.	11334871S-A-R1
Date	November 4, 2016
Temperature / Humidity	24 deg. C / 40 % RH
Engineer	Kenichi Adachi
Mode	Tx OFDM, VHT20, MIMO, Antenna: 0 (worst)

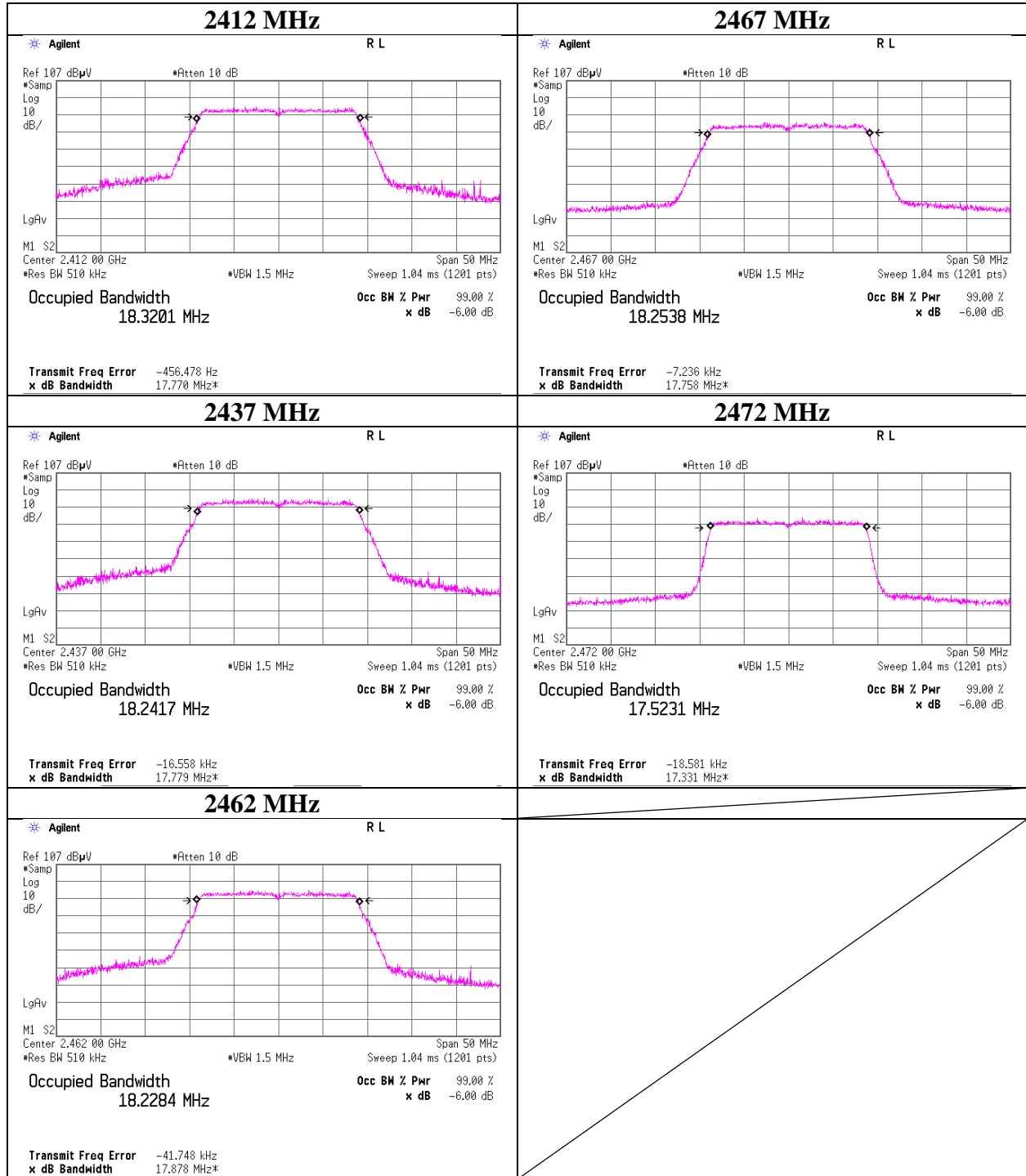

99 % Occupied Bandwidth

Test place	Shonan EMC Lab. No.1 Measurement Room
Report No.	11334871S-A-R1
Date	November 4, 2016
Temperature / Humidity	24 deg. C / 40 % RH
Engineer	Kenichi Adachi
Mode	Tx 11n-40, MIMO, Antenna: 0 (worst)

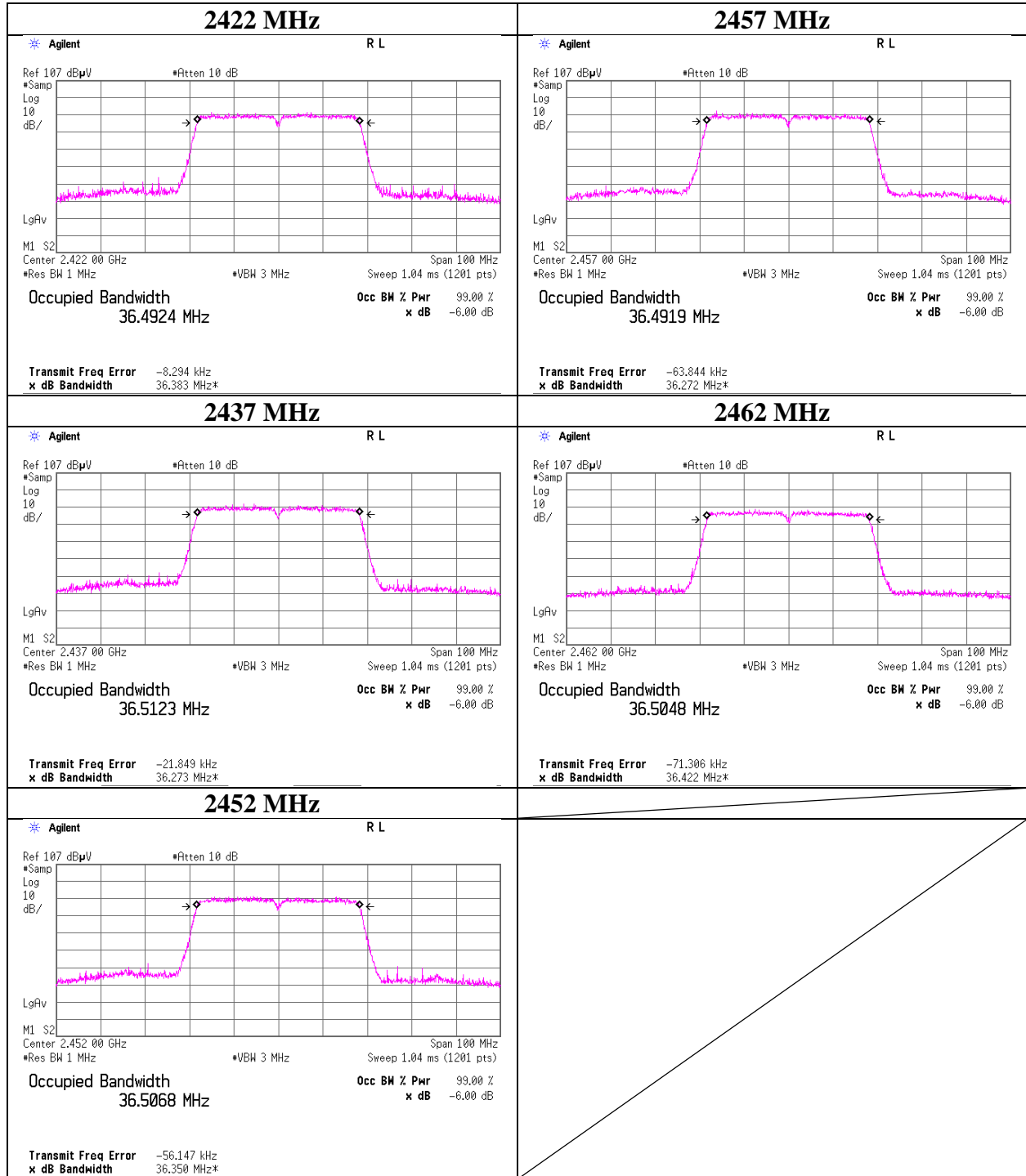

99 % Occupied Bandwidth

Test place	Shonan EMC Lab. No.1 Measurement Room
Report No.	11334871S-A-R1
Date	November 4, 2016
Temperature / Humidity	24 deg. C / 40 % RH
Engineer	Kenichi Adachi
Mode	Tx OFDM, VHT40, MIMO, Antenna: 0 (worst)

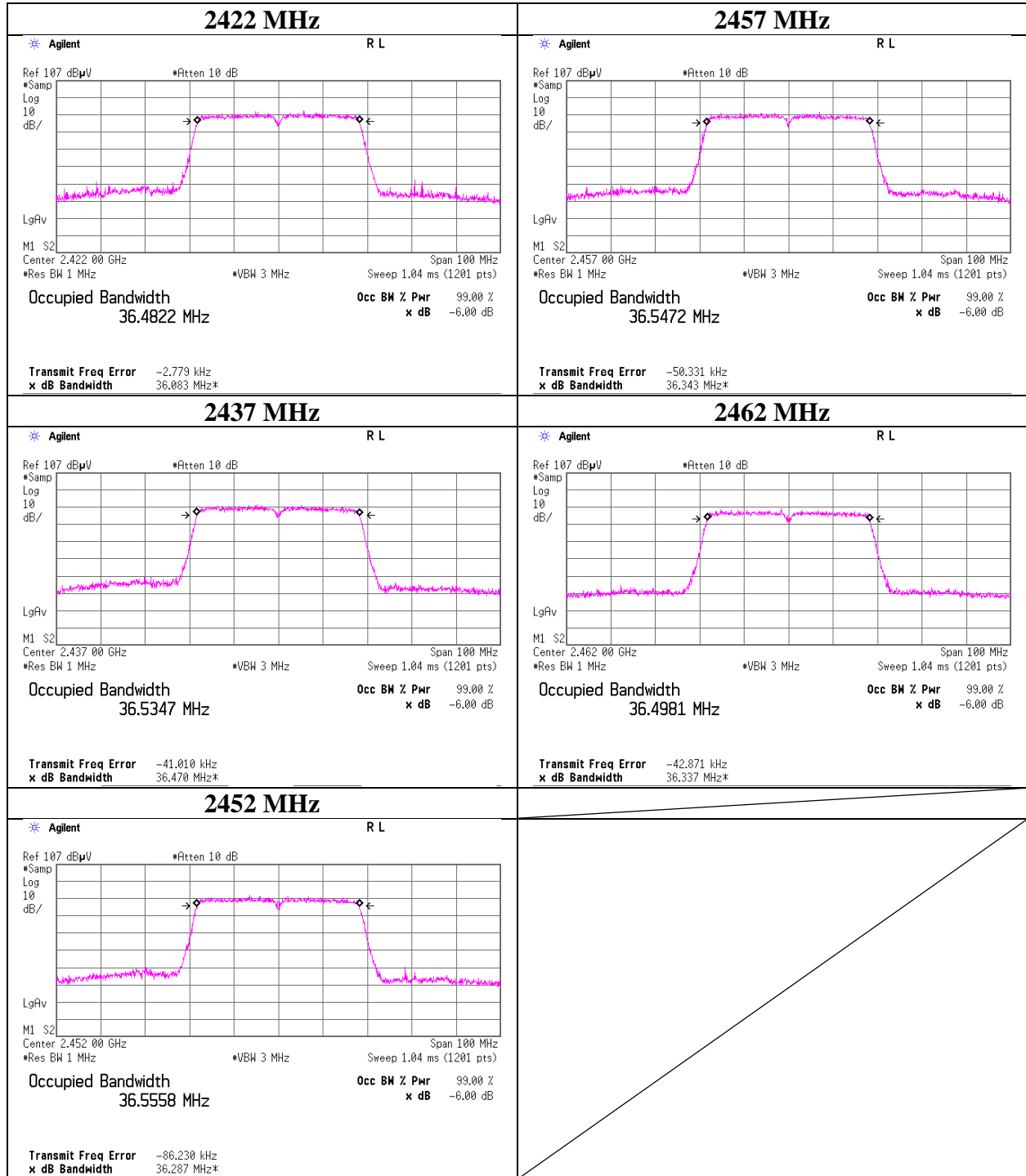

APPENDIX 2: Test instruments

Test equipment (1/2)

Control No.	Instrument	Manufacturer	Model No	Serial No	Test Item	Calibration Date * Interval(month)
SPM-07	Power Meter	Agilent	8990B	MY5100272	AT	2016/04/04 * 12
SPSS-04	Power sensor	Agilent	N1923A	MY5326009	AT	2016/04/04 * 12
SRENT-05	Spectrum Analyzer	KEYSIGHT	E4440A	MY46187752	AT	2016/11/04 * 12
SAT20-07	Attenuator	Weinschel Corp.	54A-20	31484	AT	2016/04/18 * 12
SCC-G32	Coaxial Cable	Junkosha	MWX241-0200 0KMSKMS	OCT-09-13-005	AT	2016/11/07 * 12
SCC-G31	Coaxial Cable	Junkosha	MWX241-0100 0KMSKMS	OCT-08-13-046	AT	2016/04/18 * 12
STM-G5	Terminator	Weinschel	M1459A	U6594	AT	2016/07/27 * 12
SOS-13	Humidity Indicator	Custom	CTH-202	Q.C.17	AT	2015/12/07 * 12
KTS-08	Digital Tester	SANWA	PC500	7019224	AT, RE	2016/03/15 * 12
SOS-06	Humidity Indicator	A&D	AD-5681	4062118	AT, CE	2015/12/07 * 12
SAF-04	Pre Amplifier	TOYO Corporation	TPA0118-36	1440489	RE	2016/03/22 * 12
SCC-G04	Coaxial Cable	Junkosha	J12J102207-00	JUN-12-14-018	RE	2016/06/23 * 12
SCC-G23	Coaxial Cable	Suhner	SUCOFLEX 104	297342/4	RE	2016/05/11 * 12
SHA-03	Horn Antenna	Schwarzbeck	BBHA9120D	9120D-739	RE	2016/08/22 * 12
KHA-02	Horn Antenna	Schwarzbeck	BBHA9120D	230	RE	2016/06/24 * 12
SOS-05	Humidity Indicator	A&D	AD-5681	4062518	RE	2016/10/12 * 12
KSA-08	Spectrum Analyzer	Agilent	E4446A	MY46180525	RE, AT	2016/10/11 * 12
SJM-15	Measure	ASKUL	-	-	RE	-
SJM-02	Measure	KOMELON	KMC-36	-	RE, CE	-
SAEC-03(SVS WR)	Semi-Anechoic Chamber	TDK	SAEC-03(SVS WR)	3	RE	2016/07/25 * 12
COTS-SEMI-1	EMI Software	TSJ	TEPTO-DV(RE ,CE,RFI,MF)	-	RE, CE	-
STS-03	Digital Hitester	Hioki	3805-50	080997823	RE, CE	2016/10/17 * 12
SAT10-05	Attenuator(above1G Hz)	Agilent	8493C-010	74864	RE, AT	2016/11/07 * 12
SFL-02	Highpass Filter	MICRO-TRONICS	HPM50111	051	RE	2015/11/16 * 12
SRENT-06	Spectrum Analyzer	KEYSIGHT	E4440A	MY48250921	RE	2016/08/07 * 12
SAT10-06	Attenuator	Agilent	8493C-010	74865	RE	2016/11/07 * 12
MSA-16	Spectrum Analyzer	Agilent	E4440A	MY46186390	RE	2016/02/08 * 12
KAF-02	Pre Amplifier	Hewlett Packard	8449B	3008A01268	RE	2016/04/22 * 12

The expiration date of the calibration is the end of the expired month.

All equipment is calibrated with valid calibrations. Each measurement data is traceable to the national or international standards.

As for some calibrations performed after the tested dates, those test equipment have been controlled by means of an unbroken chains of calibrations.

Test Item: CE: Conducted Emission test
RE: Radiated Emission test
AT: Antenna Terminal Conducted test

Tested date:
- Conducted emission test : November 10 to 14, 2016
- Radiated emissions test : August 22 to November 10, 2016
- Antenna Terminal Conducted test : August 18 to November 11, 2016

UL Japan, Inc.

Shonan EMC Lab.

1-22-3 Megumigaoka, Hiratsuka-shi, Kanagawa-ken, 259-1220 JAPAN

Telephone : +81 463 50 6400

Facsimile : +81 463 50 6401

Test equipment (2/2)

Control No.	Instrument	Manufacturer	Model No	Serial No	Test Item	Calibration Date * Interval(month)
SAEC-03(NSA)	Semi-Anechoic Chamber	TDK	SAEC-03(NSA)	3	RE	2016/07/15 * 12
SBA-03	Biconical Antenna	Schwarzbeck	BBA9106	91032666	RE	2016/10/18 * 12
SLA-07	Logperiodic Antenna	Schwarzbeck	VUSLP9111B	196	RE	2016/01/30 * 12
SAT6-08	Attenuator	HIROSE ELECTRIC CO.,LTD.	AT-406(40)	-	RE	2016/08/04 * 12
SCC-C1/C2/C3 /C4/C5/C10/SR SE-03	Coaxial Cable&RF Selector	Fujikura/Fujikura/Suhner/Suhner/Suhner/Suhner/TOYO	8D2W/12DSFA /141PE/141PE/141PE/141PE/NS4906	-/0901-271(RF Selector)	RE	2016/04/22 * 12
SAF-03	Pre Amplifier	SONOMA	310N	290213	RE	2016/02/25 * 12
STR-06	Test Receiver	Rohde & Schwarz	ESCI	101259	RE, CE	2016/03/28 * 12
SHA-04	Horn Antenna	ETS LINDGREN	3160-09	LM3640	RE	2016/03/15 * 12
SAF-08	Pre Amplifier	TOYO Corporation	HAP18-26W	00000019	RE	2016/03/23 * 12
SCC-G33	Coaxial Cable	Junkosha	MWX241-0100 0KMSKMS	-	RE	2016/04/18 * 12
SCC-G15	Coaxial Cable	Suhner	SUCOFLEX 102	32703/2	RE	2016/03/08 * 12
SRENT-08	Spectrum Analyzer	Agilent	E4448A	MY50180019	RE	2016/10/24 * 12
SCC-C9/C10/S RSE-03	Coaxial Cable&RF Selector	Suhner/Suhner/TOYO	RG223U/141PE /NS4906	-/0901-271(RF Selector)	CE	2016/04/22 * 12
SLS-05	LISN	Rohde & Schwarz	ENV216	100516	CE(EUT)	2016/02/09 * 12
SLS-02	LISN	Rohde & Schwarz	ENV216	100512	CE(AE)	2016/02/09 * 12
SAT3-07	Attenuator	JFW	50HF-003N	-	CE	2016/09/23 * 12
STM-05	Terminator	TME	CT-01 BP	-	CE	2015/12/18 * 12

The expiration date of the calibration is the end of the expired month.

All equipment is calibrated with valid calibrations. Each measurement data is traceable to the national or international standards.

As for some calibrations performed after the tested dates, those test equipment have been controlled by means of an unbroken chains of calibrations.

Test Item: CE: Conducted Emission test
RE: Radiated Emission test
AT: Antenna Terminal Conducted test

Tested date:
- Conducted emission test : November 10 to 14, 2016
- Radiated emissions test : August 22 to November 10, 2016
- Antenna Terminal Conducted test : August 18 to November 11, 2016

UL Japan, Inc.

Shonan EMC Lab.

1-22-3 Megumigaoka, Hiratsuka-shi, Kanagawa-ken, 259-1220 JAPAN
Telephone : +81 463 50 6400
Facsimile : +81 463 50 6401