

FCC Radio Test Report

FCC ID: BJIOH0007

This report concerns (check one): Original Grant Class II Change

Project No. : 1606167
Equipment : Modular
Model Name : TRW-USM-10
Applicant : TOSHIBA TEC Corporation
Address : 6-78, Minami-Cho, Mishima-shi, Shizuoka-Ken,
Japan, 411-8520

Date of Receipt : Jun. 24, 2016
Date of Test : Jun. 24, 2016 ~ Aug. 29, 2016
Issued Date : Aug. 30, 2016
Tested by : BTL Inc.

Testing Engineer : Rush Kao
(Rush Kao)

Technical Manager : Jeff Yang
(Jeff Yang)

Authorized Signatory : Andy Chiu
(Andy Chiu)

B T L I N C .

B1, No.37, Lane 365, Yang Guang St.,
Nei-Hu District, Taipei City 114, Taiwan.
TEL:+886-2-2657-3299 FAX: +886-2- 2657-3331

Declaration

BTL represents to the client that testing is done in accordance with standard procedures as applicable and that test instruments used has been calibrated with standards traceable to international standard(s) and/or national standard(s).

BTL's reports apply only to the specific samples tested under conditions. It is manufacture's responsibility to ensure that additional production units of this model are manufactured with the identical electrical and mechanical components. **BTL** shall have no liability for any declarations, inferences or generalizations drawn by the client or others from **BTL** issued reports.

BTL's report must not be used by the client to claim product certification, approval, or endorsement by NVLAP, NIST, or any agency of the Federal Government.

This report is the confidential property of the client. As a mutual protection to the clients, the public and **BTL-self**, extracts from the test report shall not be reproduced except in full with **BTL's** authorized written approval.

BTL's laboratory quality assurance procedures are in compliance with the **ISO Guide 17025** requirements, and accredited by the conformity assessment authorities listed in this test report.

Limitation

For the use of the authority's logo is limited unless the Test Standard(s)/Scope(s)/Item(s) mentioned in this test report is (are) included in the conformity assessment authorities acceptance respective.

Table of Contents	Page
1 . CERTIFICATION	7
2 . SUMMARY OF TEST RESULTS	8
2.1 TEST FACILITY	8
2.2 MEASUREMENT UNCERTAINTY	9
3 . GENERAL INFORMATION	10
3.1 GENERAL DESCRIPTION OF EUT	10
3.2 DESCRIPTION OF TEST MODES	11
3.3 TABLE OF PARAMETERS OF TEXT SOFTWARE SETTING	11
3.4 BLOCK DIAGRAM SHOWING THE CONFIGURATION OF SYSTEM TESTED	12
3.5 DESCRIPTION OF SUPPORT UNITS	12
4 . EMC EMISSION TEST	13
4.1 CONDUCTED EMISSION MEASUREMENT	13
4.1.1 POWER LINE CONDUCTED EMISSION LIMITS	13
4.1.2 TEST PROCEDURE	13
4.1.3 DEVIATION FROM TEST STANDARD	13
4.1.4 TEST SETUP	14
4.1.5 EUT OPERATING CONDITIONS	14
4.1.6 EUT TEST CONDITIONS	14
4.1.7 TEST RESULTS	14
4.2 RADIATED EMISSION MEASUREMENT	15
4.2.1 RADIATED EMISSION LIMITS	15
4.2.2 TEST PROCEDURE	16
4.2.3 DEVIATION FROM TEST STANDARD	16
4.2.4 TEST SETUP	17
4.2.5 EUT OPERATING CONDITIONS	18
4.2.6 EUT TEST CONDITIONS	18
4.2.7 TEST RESULTS (9KHZ TO 30MHZ)	18
4.2.8 TEST RESULTS (BETWEEN 30MHZ TO 1000 MHZ)	19
4.2.9 TEST RESULTS (ABOVE 1000 MHZ)	19
5 . NUMBER OF HOPPING CHANNEL	20
5.1 APPLIED PROCEDURES	20
5.1.1 TEST PROCEDURE	20
5.1.2 DEVIATION FROM STANDARD	20
5.1.3 TEST SETUP	20
5.1.4 EUT OPERATION CONDITIONS	20
5.1.5 EUT TEST CONDITIONS	20
5.1.6 TEST RESULTS	20

Table of Contents	Page
6 . AVERAGE TIME OF OCCUPANCY	21
6.1 APPLIED PROCEDURES / LIMIT	21
6.1.1 TEST PROCEDURE	21
6.1.2 DEVIATION FROM STANDARD	21
6.1.3 TEST SETUP	21
6.1.4 EUT OPERATION CONDITIONS	22
6.1.5 EUT TEST CONDITIONS	22
6.1.6 TEST RESULTS	22
7 . HOPPING CHANNEL SEPARATION MEASUREMENT	23
7.1 APPLIED PROCEDURES / LIMIT	23
7.1.1 TEST PROCEDURE	23
7.1.2 DEVIATION FROM STANDARD	23
7.1.3 TEST SETUP	23
7.1.4 EUT TEST CONDITIONS	23
7.1.5 TEST RESULTS	23
8 . BANDWIDTH TEST	24
8.1 APPLIED PROCEDURES	24
8.1.1 TEST PROCEDURE	24
8.1.2 DEVIATION FROM STANDARD	24
8.1.3 TEST SETUP	24
8.1.4 EUT OPERATION CONDITIONS	24
8.1.5 EUT TEST CONDITIONS	24
8.1.6 TEST RESULTS	24
9 . PEAK OUTPUT POWER TEST	25
9.1 APPLIED PROCEDURES / LIMIT	25
9.1.1 TEST PROCEDURE	25
9.1.2 DEVIATION FROM STANDARD	25
9.1.3 TEST SETUP	25
9.1.4 EUT OPERATION CONDITIONS	25
9.1.5 EUT TEST CONDITIONS	25
9.1.6 TEST RESULTS	25
10 . ANTENNA CONDUCTED SPURIOUS EMISSION	26
10.1 APPLIED PROCEDURES / LIMIT	26
10.1.1 TEST PROCEDURE	26
10.1.2 DEVIATION FROM STANDARD	26
10.1.3 TEST SETUP	26
10.1.4 EUT OPERATION CONDITIONS	26
10.1.5 EUT TEST CONDITIONS	26
10.1.6 TEST RESULTS	26
11 . MEASUREMENT INSTRUMENTS LIST	27

Table of Contents	Page
12 . EUT TEST PHOTO	29
ATTACHMENT A - CONDUCTED EMISSION	34
ATTACHMENT B - RADIATED EMISSION (9KHZ TO 30MHZ)	37
ATTACHMENT C - RADIATED EMISSION (30MHZ TO 1000MHZ)	50
ATTACHMENT D - RADIATED EMISSION (ABOVE 1000MHZ)	57
ATTACHMENT E - NUMBER OF HOPPING CHANNEL	70
ATTACHMENT F - AVERAGE TIME OF OCCUPANCY	72
ATTACHMENT G - HOPPING CHANNEL SEPARATION MEASUREMENT	78
ATTACHMENT H - BANDWIDTH	81
ATTACHMENT I - PEAK OUTPUT POWER	84
ATTACHMENT J - ANTENNA CONDUCTED SPURIOUS EMISSION	87

REPORT ISSUED HISTORY

Issued No.	Description	Issued Date
BTL-FCCP-1-1606167	Original Issue.	Aug. 30, 2016

1. CERTIFICATION

Equipment : Modular
Brand Name : TOSHIBA
Model Name : TRW-USM-10
Applicant : TOSHIBA TEC Corporation
Date of Test : Jun. 24, 2016 ~ Aug. 29, 2016
Test Sample : Engineering Sample
Standard(s) : FCC Part15, Subpart C (15.247) / ANSI C63.10-2013

The above equipment has been tested and found compliance with the requirement of the relative standards by BTL Inc.

The test data, data evaluation, and equipment configuration contained in our test report (Ref No. BTL-FCCP-1-1606167) were obtained utilizing the test procedures, test instruments, test sites that has been accredited by the Authority of TAF according to the ISO-17025 quality assessment standard and technical standard(s).

2. SUMMARY OF TEST RESULTS

Test procedures according to the technical standard(s):

Applied Standard(s): 47 CFR Part 15, Subpart C			
Standard(s) Section	Test Item	Judgment	Remark
15.207	Conducted Emission	PASS	
15.247(d)	Antenna conducted Spurious Emission	PASS	
15.247(a)(1)	Hopping Channel Separation	PASS	
15.247(a)(1)(i)	Bandwidth	PASS	
15.247(b)(2)	Peak Output Power	PASS	
15.247(d)15.209	Radiated Spurious Emission	PASS	
15.247(a)(1)(i)	Number of Hopping Frequency	PASS	
15.247(a)(1)(i)	Dwell Time	PASS	
15.205	Restricted Bands	PASS	
15.203	Antenna Requirement	PASS	

NOTE:

(1) "N/A" denotes test is not applicable to this device.

2.1 TEST FACILITY

The test facilities used to collect the test data in this report:

Conducted emission Test:

C05: (VCCI RN: C-4742; FCC RN:949005; FCC DN:TW1082)
No. 68-1, Ln. 169, Sec.2, Datong Rd., Xizhi Dist., New Taipei City 221, Taiwan

Radiated emission Test (Below 1GHz):

CB15: (VCCI RN: R-4260; FCC RN:949005; FCC DN:TW1082; IC Assigned Code:20088-2)
No. 68-1, Ln. 169, Sec.2, Datong Rd., Xizhi Dist., New Taipei City 221, Taiwan

Radiated emission Test (Above 1GHz):

CB15: (VCCI RN: G-868; FCC RN:949005; FCC DN:TW1082; IC Assigned Code:20088-2)
No. 68-1, Ln. 169, Sec.2, Datong Rd., Xizhi Dist., New Taipei City 221, Taiwan

2.2 MEASUREMENT UNCERTAINTY

Where relevant, the following measurement uncertainty levels have been estimated for tests performed on the EUT as specified in CISPR 16-4-2.

The BTL measurement uncertainty is less than the CISPR 16-4-2 U_{CISPR} requirement.

The reported uncertainty of measurement $y \pm U$, where expanded uncertainty U is based on a standard uncertainty multiplied by a coverage factor of $k=2$, providing a level of confidence of approximately **95 %**.

A. Conducted Measurement :

Test Site	Method	Measurement Frequency Range	U, (dB)
C05	CISPR	150 kHz~30MHz	2.04

B. Radiated Measurement :

Test Site	Method	Measurement Frequency Range	U, (dB)
CB15 (3m)	CISPR	9kHz ~ 150kHz	4.00
		150kHz ~ 30MHz	4.00

Test Site	Method	Measurement Frequency Range	Ant. H / V	U, (dB)
CB15 (3m)	CISPR	30 MHz ~ 200 MHz	V	3.06
		30 MHz ~ 200 MHz	H	2.58
		200 MHz ~ 1, 000 MHz	V	3.50
		200 MHz ~ 1, 000 MHz	H	3.10

Test Site	Method	Measurement Frequency Range	Ant. H / V	U, (dB)
CB15 (3m)	CISPR	1GHz ~ 6GHz	V	4.14
		1GHz ~ 6GHz	H	4.14

Test Site	Method	Measurement Frequency Range	Ant. H / V	U, (dB)
CB15 (1m)	CISPR	6GHz ~ 18GHz	V	5.34
		6GHz ~ 18GHz	H	5.34

Note: Unless specifically mentioned, the uncertainty of measurement has not been taken into account to declare the compliance or non-compliance to the specification.

Our calculated Measurement Instrumentation Uncertainty is shown in the tables above. These are our U_{lab} values in CISPR 16-4-2 terminology.

Since Table 1 of CISPR 16-4-2 has values of measurement instrumentation uncertainty, called U_{CISPR} , as follows:

Conducted Disturbance (mains port) – 150 kHz – 30 MHz : 3.6 dB

Radiated Disturbance (electric field strength on an open area test site or alternative test site) – 30 MHz – 1000 MHz : 5.2 dB

It can be seen that our U_{lab} values are smaller than U_{CISPR} .

3. GENERAL INFORMATION

3.1 GENERAL DESCRIPTION OF EUT

Equipment	Modular	
Brand Name	TOSHIBA	
Model Name	TRW-USM-10	
Model Difference	N/A	
Product Description	Operation Frequency	902.75~927.75 MHz
	Modulation Technology	GFSK
	Bit Rate of Transmitter	
	Output Power (Max.)	8.98 dBm
Power Source	Battery supplied.	
Power Rating	DC 3.3V	

Note:

- For a more detailed features description, please refer to the manufacturer's specifications or the user's manual.
- Channel List:**

Channel	Frequency (MHz)
01	902.75
02	915.25
03	927.25

3. Table for Filed Antenna

Ant.	Brand	Model Name	Antenna Type	Connector	Gain (dBi)
1	TOSHIBA TEC	ASYB-ANTEN NA-RFID-EX	PCB	u.FL	-14

3.2 DESCRIPTION OF TEST MODES

To investigate the maximum EMI emission characteristics generated from EUT, the test system was pre-scanning tested based on the consideration of following EUT operation mode or test configuration mode which possibly have effect on EMI emission level. Each of these EUT operation mode(s) or test configuration mode(s) mentioned above was evaluated respectively.

Pretest Mode	Description
Mode 1	TX Mode NOTE (1)
Mode 2	RFID

The EUT system operated these modes were found to be the worst case during the pre-scanning test as following:

For Conducted Test	
Final Test Mode	Description
Mode 2	RFID

For Radiated Test	
Final Test Mode	Description
Mode 1	TX Mode NOTE (1)

Note:

(1) The measurements are performed at the high, middle, low available channels.

3.3 TABLE OF PARAMETERS OF TEST SOFTWARE SETTING

During testing channel & power controlling software provided by the customer was used to control the operating channel as well as the output power level. The RF output power selection is for the setting of RF output power expected by the customer and is going to be fixed on the firmware of the final end product power parameters of WLAN

Test Software Version	RF test for FCC V1.0		
Frequency (MHz)	902.75	915.25	927.25
RFID	4	7	8

3.4 BLOCK DIAGRAM SHOWING THE CONFIGURATION OF SYSTEM TESTED

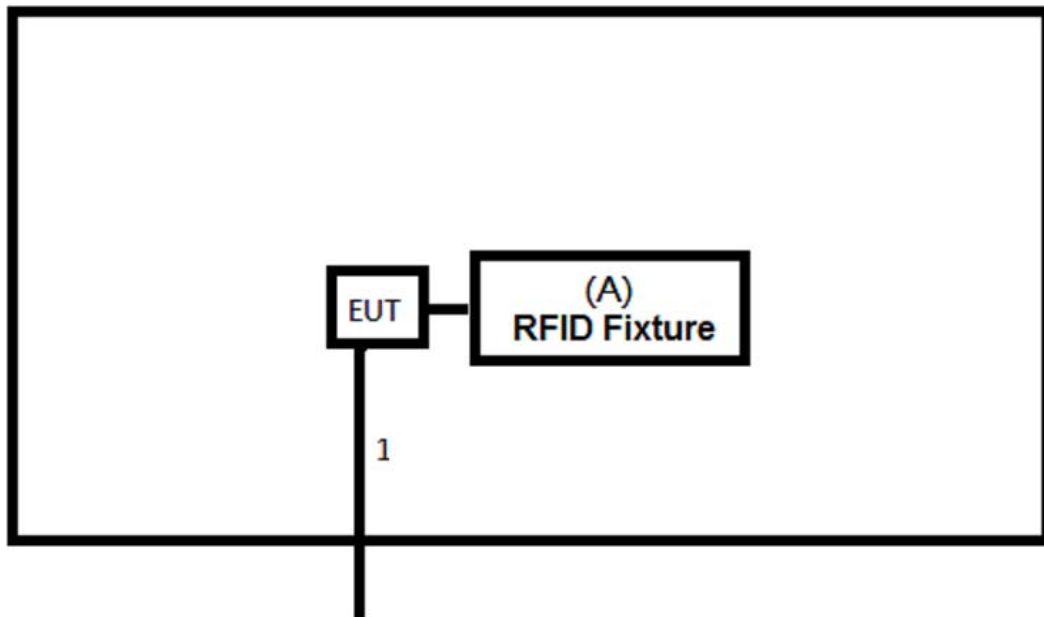

3.5 DESCRIPTION OF SUPPORT UNITS

The EUT has been tested as an independent unit together with other necessary accessories or support units. The following support units or accessories were used to form a representative test configuration during the tests.

Item	Equipment	Mfr/Brand	Model/Type No.	FCC ID/IC	Series No.
A	RFID Fixture	N/A	N/A	N/A	N/A

Item	Shielded Type	Ferrite Core	Length	Note
1	NO	NO	1m	Power Cable

Note:

- (1) For detachable type I/O cable should be specified the length in m in 『Length』 column.

4. EMC EMISSION TEST

4.1 CONDUCTED EMISSION MEASUREMENT

4.1.1 POWER LINE CONDUCTED EMISSION Limits (Frequency Range 150KHz-30MHz)

Frequency of Emission (MHz)	Conducted Limit (dB μ V)	
	Quasi-peak	Average
0.15 -0.5	66 to 56*	56 to 46*
0.50 -5.0	56	46
5.0 -30.0	60	50

Note:

- (1) The limit of " * " decreases with the logarithm of the frequency
- (2) The test result calculated as following:
 Measurement Value = Reading Level + Correct Factor
 Correct Factor = Antenna Factor + Cable Loss - Amplifier Gain(if use)
 Margin Level = Measurement Value - Limit Value

The following table is the setting of the receiver

Receiver Parameters	Setting
Attenuation	10 dB
Start Frequency	0.15 MHz
Stop Frequency	30 MHz
IF Bandwidth	9 kHz

4.1.2 TEST PROCEDURE

- a. The EUT was placed 0.8 meters from the horizontal ground plane with EUT being connected to the power mains through a line impedance stabilization network (LISN). All other support equipments powered from additional LISN(s). The LISN provide 50 Ohm/ 50uH of coupling impedance for the measuring instrument.
- b. Interconnecting cables that hang closer than 40 cm to the ground plane shall be folded back and forth in the center forming a bundle 30 to 40 cm long.
- c. I/O cables that are not connected to a peripheral shall be bundled in the center. The end of the cable may be terminated, if required, using the correct terminating impedance. The overall length shall not exceed 1 m.
- d. LISN at least 80 cm from nearest part of EUT chassis.
- e. For the actual test configuration, please refer to the related Item –EUT Test Photos.

4.1.3 DEVIATION FROM TEST STANDARD

No deviation

4.1.4 TEST SETUP

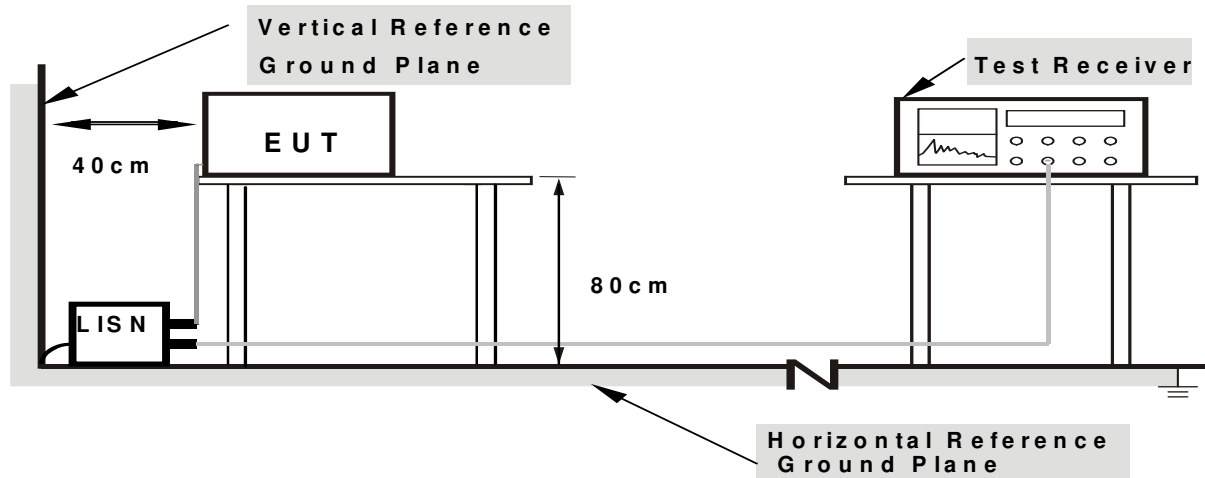

- Note:**
1. Support units were connected to second LISN.
 2. Both of LISNs (AMN) are 80 cm from EUT and at least 80 from other units and other metal planes

4.1.5 EUT OPERATING CONDITIONS

The EUT was configured for testing in a typical function (as a customer would normally use it), EUT was programmed to be in continuously transmitting/receiving data or hopping on mode.

4.1.6 EUT TEST CONDITIONS

Temperature: 25°C
 Relative Humidity: 55%
 Test Voltage: AC 120V/60Hz

4.1.7 TEST RESULTS

Please refer to the Attachment A.

Remark:

- (1) All readings are QP Mode value unless otherwise stated AVG in column of 『Note』. If the QP Mode Measured value compliance with the QP Limits and lower than AVG Limits, the EUT shall be deemed to meet both QP & AVG Limits and then only QP Mode was measured, but AVG Mode didn't perform. In this case, a “*” marked in AVG Mode column of Interference Voltage Measured.
- (2) Measuring frequency range from 150KHz to 30MHz.
- (3) “N/A” denotes test is not applicable to this device.

4.2 RADIATED EMISSION MEASUREMENT

4.2.1 RADIATED EMISSION LIMITS

In case the emission fall within the restricted band specified on 15.205(a), then the 15.209(a) limit in the table below has to be followed.

LIMITS OF RADIATED EMISSION MEASUREMENT (9KHz-1000MHz)

Frequency (MHz)	Field Strength (microvolts/meter)	Measurement Distance (meters)
0.009~0.490	2400/F(KHz)	300
0.490~1.705	24000/F(KHz)	30
1.705~30.0	30	30
30~88	100	3
88~216	150	3
216~960	200	3
960~1000	500	3

LIMITS OF RADIATED EMISSION MEASUREMENT (Above 1000MHz)

Frequency (MHz)	(dBuV/m) (at 3 meters)	
	PEAK	AVERAGE
Above 1000	74	54

Notes:

- (1) The limit for radiated test was performed according to FCC PART 15C.
- (2) The tighter limit applies at the band edges.
- (3) Emission level (dBuV/m)=20log Emission level (uV/m).
- (4) The test result calculated as following:
 Measurement Value = Reading Level + Correct Factor
 Correct Factor = Antenna Factor + Cable Loss - Amplifier Gain(if use)
 Margin Level = Measurement Value - Limit Value

Spectrum Parameter	Setting
Attenuation	Auto
Start Frequency	1000 MHz
Stop Frequency	10th carrier harmonic
RBW / VBW (Emission in restricted band)	RBW 1MHz VBW 3MHz peak detector for Pk value RMS detector for AV value

Receiver Parameter	Setting
Attenuation	Auto
Start ~ Stop Frequency	9KHz~90KHz for PK/AVG detector
Start ~ Stop Frequency	90KHz~110KHz for QP detector
Start ~ Stop Frequency	110KHz~490KHz for PK/AVG detector
Start ~ Stop Frequency	490KHz~30MHz for QP detector
Start ~ Stop Frequency	30MHz~1000MHz for QP detector

4.2.2 TEST PROCEDURE

- a. The measuring distance of 3 m shall be used for measurements. The EUT was placed on the top of a rotating table 0.8 meter above the ground at a 3 meter semi-anechoic chamber. The table was rotated 360 degrees to determine the position of the highest radiation.(below 1GHz)
- b. The measuring distance of 3 m shall be used for measurements. The EUT was placed on the top of a rotating table 1.5 meter above the ground at a 3 meter semi-anechoic chamber. The table was rotated 360 degrees to determine the position of the highest radiation.(above 1GHz)
- c. The height of the equipment or of the substitution antenna shall be 0.8 m or 1.5 m, the height of the test antenna shall vary between 1 m to 4 m. Both horizontal and vertical polarizations of the antenna are set to make the measurement.
- d. For each suspected emission, the EUT was arranged to its worst case and then the antenna was tuned to heights find the maximum reading (used Bore sight function).
- e. The receiver system was set to peak and average detect function and specified bandwidth with maximum hold mode when the test frequency is above 1GHz.
- f. The initial step in collecting radiated emission data is a receiver peak detector mode pre-scanning the measurement frequency range. Significant peaks are then marked and then Quasi Peak detector mode re-measured.
- g. All readings are Peak unless otherwise stated QP in column of Note. Peak denotes that the Peak reading compliance with the QP Limits and then QP Mode measurement didn't perform. (below 1GHz)
- h. All readings are Peak Mode value unless otherwise stated AVG in column of Note. If the Peak Mode Measured value compliance with the Peak Limits and lower than AVG Limits, the EUT shall be deemed to meet both Peak & AVG Limits and then only Peak Mode was measured, but AVG Mode didn't perform. (above 1GHz)
- i. For the actual test configuration, please refer to the related Item –EUT Test Photos.

4.2.3 DEVIATION FROM TEST STANDARD

No deviation

4.2.4 TEST SETUP

(A) Radiated Emission Test Set-Up Frequency Below 1 GHz

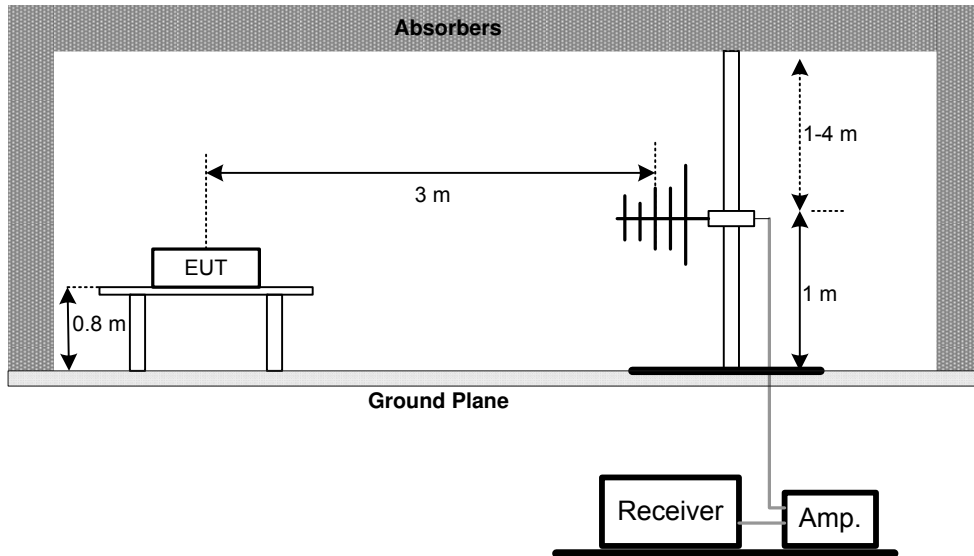

(B) Radiated Emission Test Set-Up Frequency Above 1 GHz

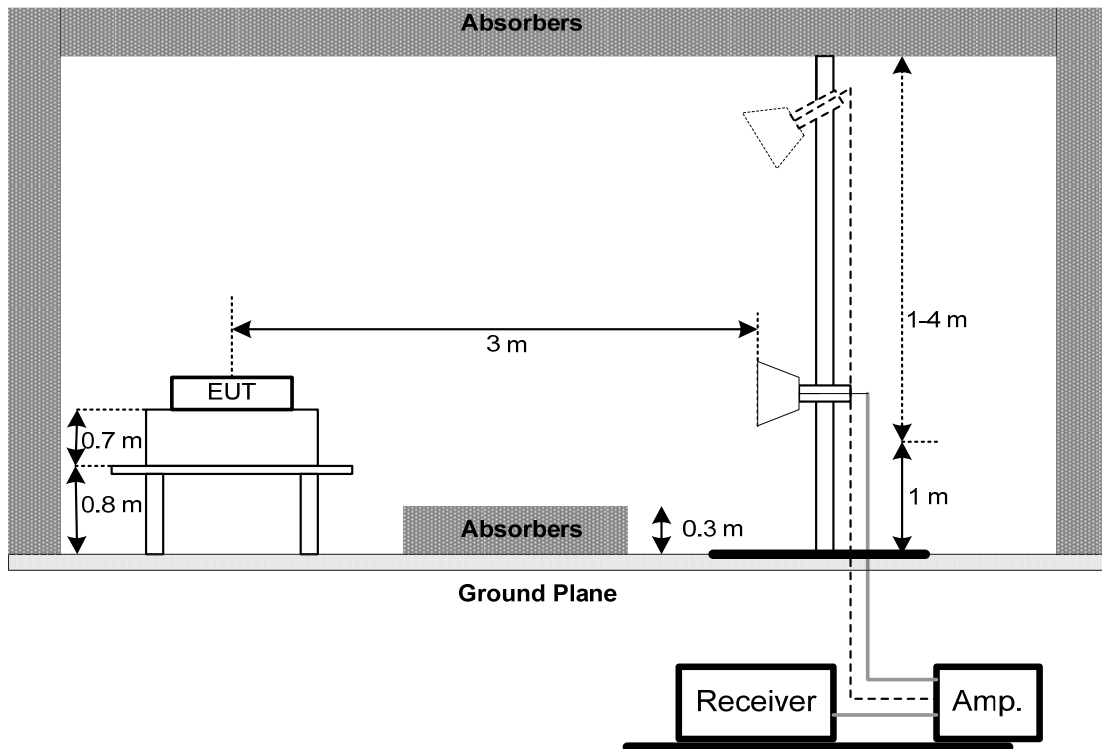

(C) For radiated emissions below 30MHz

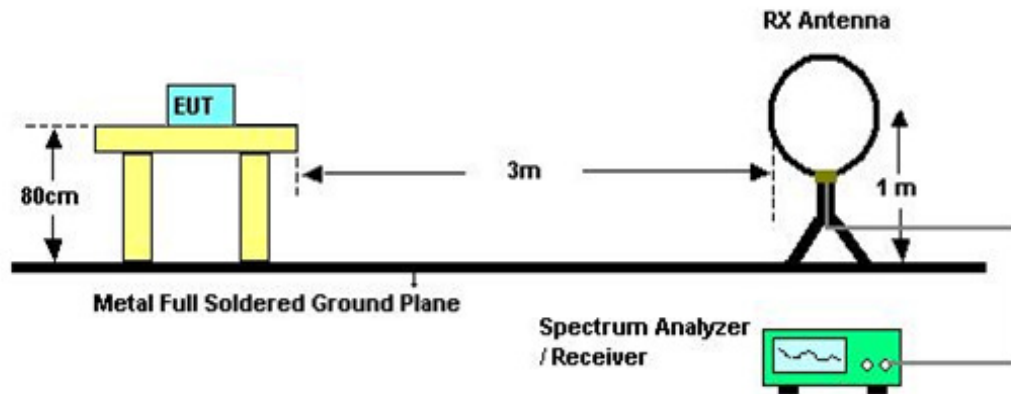

4.2.5 EUT OPERATING CONDITIONS

The EUT tested system was configured as the statements of 4.1.5 unless otherwise a special operating condition is specified in the follows during the testing.

4.2.6 EUT TEST CONDITIONS

- Temperature: 25°C
- Relative Humidity: 45%
- Test Voltage: AC 120V/60Hz

4.2.7 TEST RESULTS (9KHZ TO 30MHZ)

Please refer to the Attachment B

Remark:

- (1) The amplitude of spurious emissions which are attenuated by more than 20 dB below the permissible value has no need to be reported.
- (2) Distance extrapolation factor = $40 \log (\text{specific distance} / \text{test distance})$ (dB).
- (3) Limit line = specific limits (dBuV) + distance extrapolation factor.

4.2.8 TEST RESULTS (BETWEEN 30MHZ TO 1000 MHZ)

Please refer to the Attachment C.

Remark:

- (1) All readings are Peak unless otherwise stated QP in column of 『Note』 . Peak denotes that the Peak reading compliance with the QP Limits and then QP Mode measurement didn't perform.
- (2) Measuring frequency range from 30MHz to 1000MHz.
- (3) If the peak scan value lower limit more than 20dB, then this signal data does not show in table.

4.2.9 TEST RESULTS (ABOVE 1000 MHZ)

Please refer to the Attachment D.

Remark:

- (1) All readings are Peak unless otherwise stated QP in column of 『Note』 . Peak denotes that the Peak reading compliance with the QP Limits and then QP Mode measurement didn't perform.
- (2) Radiated emissions measured in frequency range above 1000MHz were made with an instrument using Peak detector mode and AV detector mode of the emission
- (3) A preamp and high pass filter were used for this test in order to provide sufficient measurement sensitivity.
- (4) EUT Orthogonal Axis:
"X" - denotes Laid on Table ; "Y" - denotes Vertical Stand ; "Z" - denotes Side Stand
- (5) During the measurements above 1 GHz it is taken care of that the EUT is always within the 3 dB cone of radiation BW of the used antenna
- (6) No limit: This is fundamental signal, the judgment is not applicable.
For fundamental signal judgment was referred to Peak output test.

5. NUMBER OF HOPPING CHANNEL

5.1 APPLIED PROCEDURES

FCC Part15 (15.247) , Subpart C			
Section	Test Item	Frequency Range (MHz)	Result
15.247(a)(1)(i)	Number of Hopping Channel	902.75~927.75	PASS

Spectrum Parameters	Setting
Attenuation	Auto
Span Frequency	> Operating Frequency Range
RBW	100 KHz
VBW	100 KHz
Detector	Peak
Trace	Max Hold
Sweep Time	Auto

5.1.1 TEST PROCEDURE

- a. The EUT was directly connected to the spectrum analyzer and antenna output port as show in the block diagram below,
- b. Spectrum Setting: RBW=100KHz, VBW=100KHz, Sweep time = Auto.

5.1.2 DEVIATION FROM STANDARD

No deviation.

5.1.3 TEST SETUP



5.1.4 EUT OPERATION CONDITIONS

The EUT tested system was configured as the statements of 4.1.5 unless otherwise a special operating condition is specified in the follows during the testing.

5.1.5 EUT TEST CONDITIONS

Temperature: 25°C
 Relative Humidity: 60%
 Test Voltage: AC 120V/60Hz

5.1.6 TEST RESULTS

Please refer to the Attachment E

6. AVERAGE TIME OF OCCUPANCY

6.1 APPLIED PROCEDURES / LIMIT

FCC Part15 (15.247) , Subpart C				
Section	Test Item	Limit	Frequency Range (MHz)	Result
15.247(a)(1)(i)	Average Time of Occupancy	0.4sec	902.75~927.75	PASS

6.1.1 TEST PROCEDURE

- a. The transmitter output (antenna port) was connected to the spectrum analyzer
- b. Set RBW of spectrum analyzer to 1MHz and VBW to 1MHz.
- c. Use a video trigger with the trigger level set to enable triggering only on full pulses.
- d. Sweep Time is more than once pulse time.
- e. Set the center frequency on any frequency would be measure and set the frequency span to zero span.
- f. Measure the maximum time duration of one single pulse.
- g. Set the EUT for DH5, DH3 and DH1 packet transmitting.
- h. Measure the maximum time duration of one single pulse.
- i. DH5 Packet permit maximum $1600 / 79 / 6 = 3.37$ hops per second in each channel (5 time slots TX, 1 time slot RX). So, the dwell time is the time duration of the pulse times $3.37 \times 31.6 = 106.6$ within 31.6 seconds.
- j. DH3 Packet permit maximum $1600 / 79 / 4 = 5.06$ hops per second in each channel (3 time slots TX, 1 time slot RX). So, the dwell time is the time duration of the pulse times $5.06 \times 31.6 = 160$ within 31.6 seconds.
- k. DH1 Packet permit maximum $1600 / 79 / 2 = 10.12$ hops per second in each channel (1 time slot TX, 1 time slot RX). So, the dwell time is the time duration of the pulse times $10.12 \times 31.6 = 320$ within 31.6 seconds.

6.1.2 DEVIATION FROM STANDARD

No deviation.

6.1.3 TEST SETUP

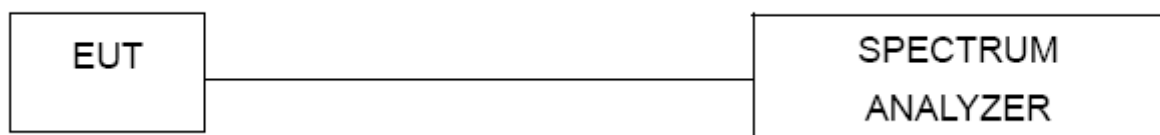

6.1.4 EUT OPERATION CONDITIONS

The EUT tested system was configured as the statements of 4.1.5 unless otherwise a special operating condition is specified in the follows during the testing.

6.1.5 EUT TEST CONDITIONS

Temperature: 25°C

Relative Humidity: 60%

Test Voltage: AC 120V/60Hz

6.1.6 TEST RESULTS

Please refer to the Attachment F

7. HOPPING CHANNEL SEPARATION MEASUREMENT

7.1 APPLIED PROCEDURES / LIMIT

Frequency hopping systems operating in the 902.75~927.75 MHz band may have hopping channel carrier frequencies that are separated by 25 KHz or two-thirds of the 20 dB bandwidth of the hopping channel, whichever is greater.

Spectrum Parameter	Setting
Attenuation	Auto
Span Frequency	> Measurement Bandwidth or Channel Separation
RBW	30 KHz
VBW	100 KHz
Detector	Peak
Trace	Max Hold
Sweep Time	Auto

7.1.1 TEST PROCEDURE

- a. The EUT must have its hopping function enabled
- b. Span = wide enough to capture the peaks of two adjacent channels
 - Resolution (or IF) Bandwidth (RBW) \geq 1% of the span
 - Video (or Average) Bandwidth (VBW) \geq RBW
 - Sweep = Auto
 - Detector function = Peak
 - Trace = Max Hold

7.1.2 DEVIATION FROM STANDARD

No deviation.

7.1.3 TEST SETUP

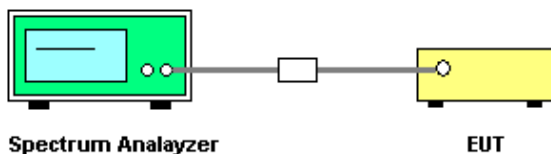

7.1.4 EUT TEST CONDITIONS

Temperature: 25°C
 Relative Humidity: 60%
 Test Voltage: AC 120V/60Hz

7.1.5 TEST RESULTS

Please refer to the Attachment G

8. BANDWIDTH TEST

8.1 APPLIED PROCEDURES

FCC Part15 (15.247) , Subpart C		
Section	Test Item	Frequency Range (MHz)
15.247(a)(2)(i)	Bandwidth	902.75~927.75

Spectrum Parameter	Setting
Attenuation	Auto
Span Frequency	> Measurement Bandwidth or Channel Separation
RBW	30 KHz (20dB Bandwidth) / 30 KHz (Channel Separation)
VBW	100 KHz (20dB Bandwidth) / 100 KHz (Channel Separation)
Detector	Peak
Trace	Max Hold
Sweep Time	Auto

8.1.1 TEST PROCEDURE

- a. The EUT was directly connected to the spectrum analyzer and antenna output port as show in the block diagram below,
- b. Spectrum Setting: RBW= 30KHz, VBW=100KHz, Sweep Time = Auto.

8.1.2 DEVIATION FROM STANDARD

No deviation.

8.1.3 TEST SETUP



8.1.4 EUT OPERATION CONDITIONS

The EUT tested system was configured as the statements of 4.1.5 unless otherwise a special operating condition is specified in the follows during the testing.

8.1.5 EUT TEST CONDITIONS

Temperature: 25°C
 Relative Humidity: 60%
 Test Voltage: AC 120V/60Hz

8.1.6 TEST RESULTS

Please refer to the Attachment H

9. PEAK OUTPUT POWER TEST

9.1 APPLIED PROCEDURES / LIMIT

FCC Part15 (15.247) , Subpart C				
Section	Test Item	Limit	Frequency Range (MHz)	Result
15.247(b)(2)	Peak Output Power	1 Watt or 30dBm	902.75~927.75	PASS

9.1.1 TEST PROCEDURE

- a. The EUT was directly connected to the spectrum analyzer and antenna output port as show in the block diagram below,
- b. Spectrum Setting: RBW= 1MHz/3MHz, VBW= 1MHz/3MHz, Sweep time = Auto.

9.1.2 DEVIATION FROM STANDARD

No deviation.

9.1.3 TEST SETUP



9.1.4 EUT OPERATION CONDITIONS

The EUT tested system was configured as the statements of 4.1.5 unless otherwise a special operating condition is specified in the follows during the testing.

9.1.5 EUT TEST CONDITIONS

Temperature: 25°C
 Relative Humidity: 60%
 Test Voltage: AC 120V/60Hz

9.1.6 TEST RESULTS

Please refer to the Attachment I

10. ANTENNA CONDUCTED SPURIOUS EMISSION

10.1 APPLIED PROCEDURES / LIMIT

In any 100 kHz bandwidth outside the frequency band in which the spread spectrum or digitally modulated device is operating, the RF power that is produced shall be at least 20 dB below that in the 100 kHz bandwidth within the band that contains the highest level of the desired power, based on either an RF conducted or a radiated measurement, provided that the transmitter demonstrates compliance with the peak conducted power limits.

10.1.1 TEST PROCEDURE

- a. The EUT was directly connected to the spectrum analyzer and antenna output port as show in the block diagram below,
- b. Spectrum Setting: RBW= 100KHz, VBW=100KHz, Sweep time = Auto.
- c. Offset=antenna gain+cable loss

10.1.2 DEVIATION FROM STANDARD

No deviation.

10.1.3 TEST SETUP



10.1.4 EUT OPERATION CONDITIONS

The EUT tested system was configured as the statements of 4.1.5 unless otherwise a special operating condition is specified in the follows during the testing.

10.1.5 EUT TEST CONDITIONS

Temperature: 25°C
 Relative Humidity: 60%
 Test Voltage: AC 120V/60Hz

10.1.6 TEST RESULTS

Please refer to the Attachment J

11. MEASUREMENT INSTRUMENTS LIST

Conducted Emission Measurement					
Item	Kind of Equipment	Manufacturer	Type No.	Serial No.	Calibrated until
1	TWO-LINE V-NETWORK	R&S	ENV216	101050	Jan. 26, 2017
2	Test Cable	TIMES	CFD300-NL	C02	Jun. 15, 2017
3	EMI Test Receiver	R&S	ESR7	101433	Dec. 10, 2016
4	Measurement Software	EZ	EZ_EMG (Version NB-03A)	N/A	N/A

Radiated Emission Measurement					
Item	Kind of Equipment	Manufacturer	Type No.	Serial No.	Calibrated until
1	Trilog-Broadband Antenna	Schwarzbeck	VULB9168-352	9168-352	Feb. 04, 2017
2	Horn Antenna	Schwarzbeck	BBHA 9120	D-546	Nov. 05, 2017
3	Pre-Amplifier	HP	8447D	2944A08891	Mar. 09 2017
4	Pre-Amplifier	Agilent	8449B	3008A02331	Jan. 24, 2017
5	Test Cable	EMCI	EMC8D-NM-N M-8000	150301	Mar. 09, 2017
6	Test Cable	EMCI	EMC104-SM-S M-2500	150303	Mar. 09, 2017
7	Test Cable	EMCI	EMC104-NM-S M-1000	150304	Mar. 09, 2017
8	Test Cable	EMCI	EMC104-SM-S M-5000	150302	Mar. 29, 2017
9	Test Cable	EMCI	EMC104-SM-S M-800	150305	Mar. 29, 2017
10	EXA Spectrum Analyzer	Agilent	N9010A	MY52220990	Feb. 24, 2017
11	EMI Test Receiver	Agilent	N9038A	MY51210215	Jan. 08, 2017
12	Loop Antenna	EMCO	6502	00042960	Nov. 06. 2016

6dB Bandwidth Measurement					
Item	Kind of Equipment	Manufacturer	Type No.	Serial No.	Calibrated until
1	Spectrum Analyzer	R&S	FSP-40	100129	Jan. 18, 2017

Peak Output Power Measurement					
Item	Kind of Equipment	Manufacturer	Type No.	Serial No.	Calibrated until
1	Power Meter	Anritsu	ML2487A	6K00004714	May 18, 2017
2	Power Meter Sensor	Anritsu	MA2491A	034138	May 17, 2017

Antenna Conducted Spurious Emission Measurement					
Item	Kind of Equipment	Manufacturer	Type No.	Serial No.	Calibrated until
1	Spectrum Analyzer	R&S	FSP-40	100129	Jan. 18, 2017

Power Spectral Density Measurement					
Item	Kind of Equipment	Manufacturer	Type No.	Serial No.	Calibrated until
1	Spectrum Analyzer	R&S	FSP-40	100129	Jan. 18, 2017

Remark: "N/A" denotes no model name, serial no. or calibration specified.
 All calibration period of equipment list is one year.

12. EUT TEST PHOTO

Conducted Measurement Photos

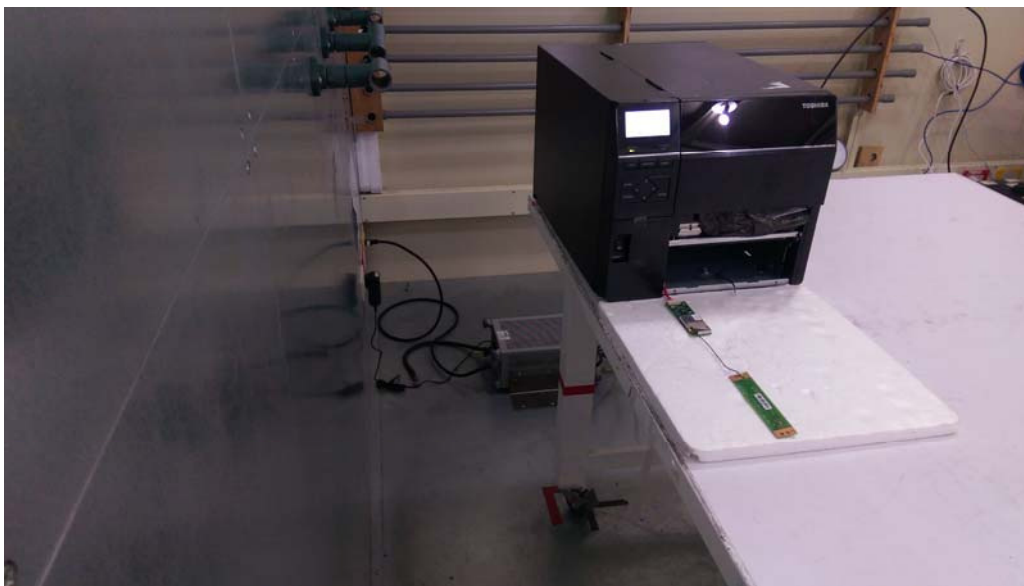

Radiated Measurement Photos

9KHz to 30MHz



Radiated Measurement Photos

30MHz to 1000MHz

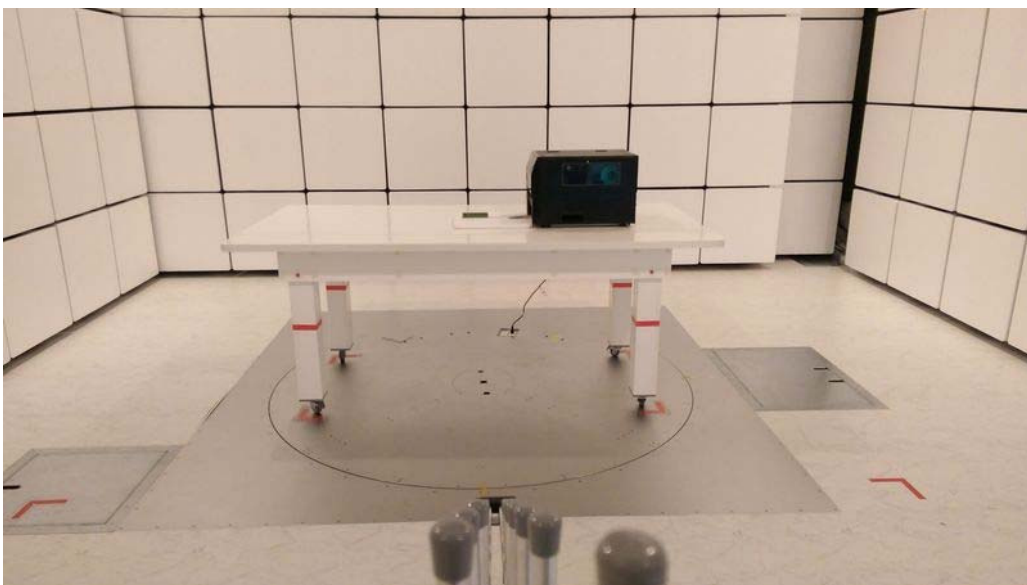
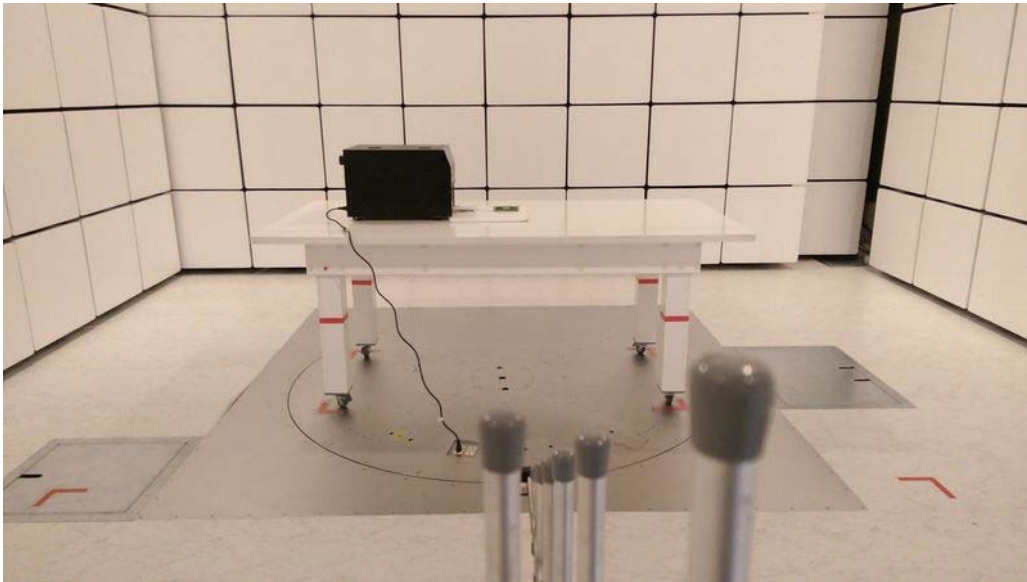

Radiated Measurement Photos

Above 1000MHz



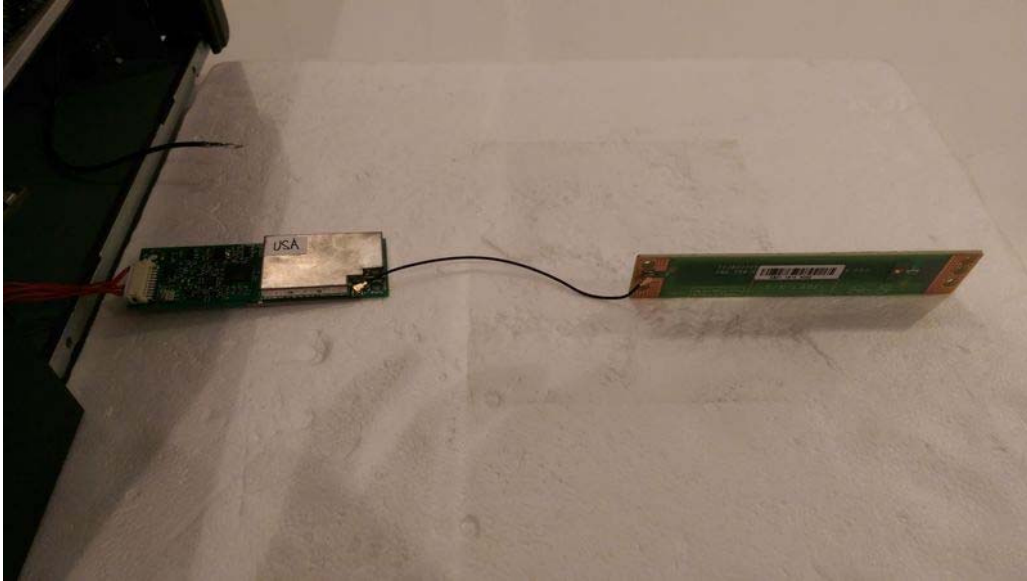

ATTACHMENT A - CONDUCTED EMISSION

Test Mode: RFID

Line

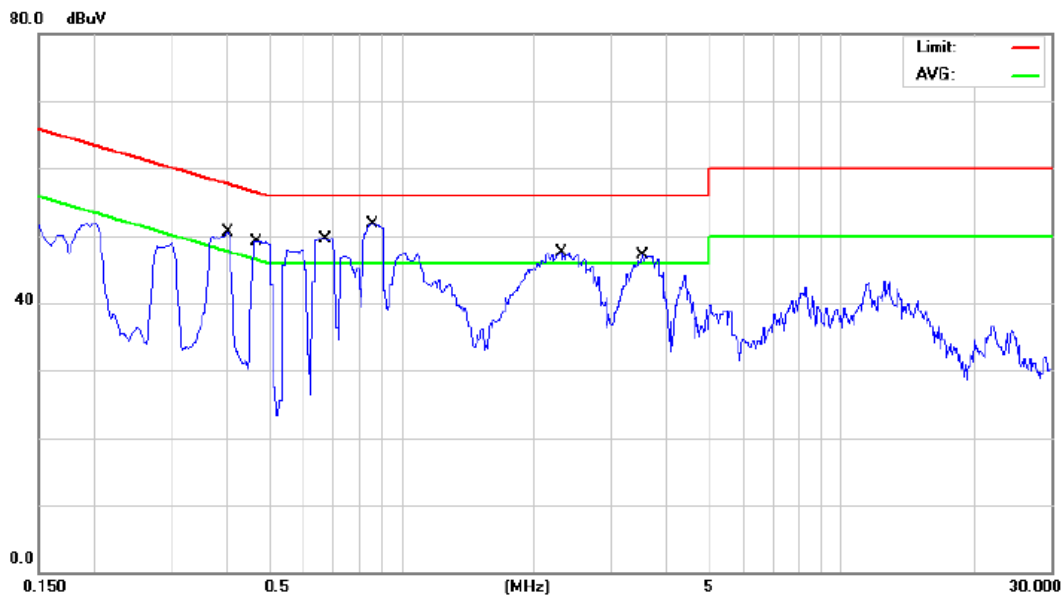

No.	Mk.	Freq. MHz	Reading Level dBuV	Correct Factor dB	Measure- ment dBuV	Limit dBuV	Margin dB	Detector	Comment
1		0.4020	38.40	9.66	48.06	57.81	-9.75	QP	
2		0.4020	26.10	9.66	35.76	47.81	-12.05	AVG	
3		0.4664	37.70	9.67	47.37	56.58	-9.21	QP	
4		0.4664	26.50	9.67	36.17	46.58	-10.41	AVG	
5		0.6710	37.90	9.67	47.57	56.00	-8.43	QP	
6		0.6710	25.00	9.67	34.67	46.00	-11.33	AVG	
7	*	0.8600	39.50	9.67	49.17	56.00	-6.83	QP	
8		0.8600	24.70	9.67	34.37	46.00	-11.63	AVG	
9		2.3000	35.50	9.74	45.24	56.00	-10.76	QP	
10		2.3000	20.20	9.74	29.94	46.00	-16.06	AVG	
11		3.5330	34.40	9.78	44.18	56.00	-11.82	QP	
12		3.5330	22.10	9.78	31.88	46.00	-14.12	AVG	

Test Mode: RFID

Neutral

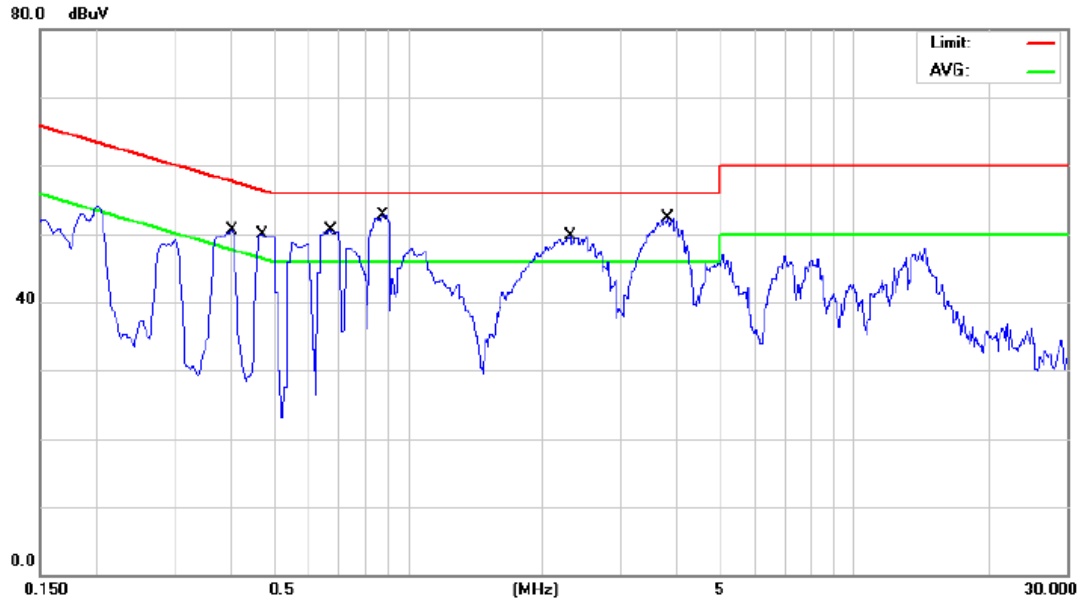

No.	Mk.	Freq. MHz	Reading Level dBuV	Correct Factor dB	Measure- ment dBuV	Limit dBuV	Margin dB	Detector	Comment
1		0.4020	38.60	9.66	48.26	57.81	-9.55	QP	
2		0.4020	25.80	9.66	35.46	47.81	-12.35	AVG	
3		0.4692	38.50	9.67	48.17	56.53	-8.36	QP	
4		0.4692	25.60	9.67	35.27	46.53	-11.26	AVG	
5		0.6710	38.60	9.67	48.27	56.00	-7.73	QP	
6		0.6710	25.00	9.67	34.67	46.00	-11.33	AVG	
7	*	0.8780	40.40	9.68	50.08	56.00	-5.92	QP	
8		0.8780	25.20	9.68	34.88	46.00	-11.12	AVG	
9		2.3090	37.80	9.75	47.55	56.00	-8.45	QP	
10		2.3090	22.60	9.75	32.35	46.00	-13.65	AVG	
11		3.8120	40.20	9.79	49.99	56.00	-6.01	QP	
12		3.8120	28.80	9.79	38.59	46.00	-7.41	AVG	

ATTACHMENT B - RADIATED EMISSION (9KHZ TO 30MHZ)

Test Mode: TX Mode_902.75 MHz

OPEN

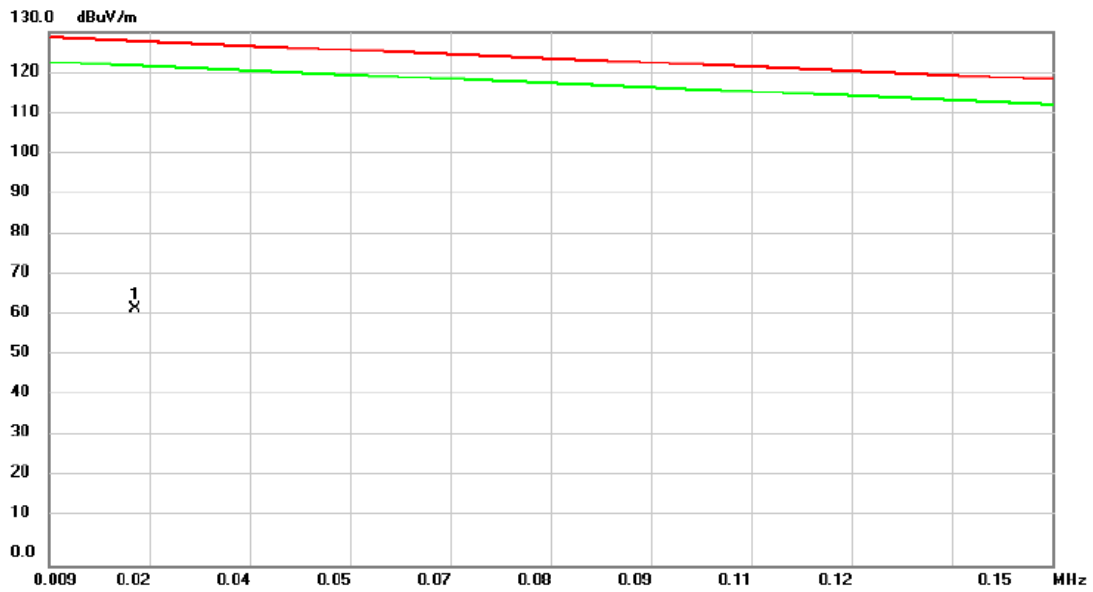

No.	Mk.	Freq.	Reading Level	Correct Factor	Measurement	Limit	Margin	Detector	Comment
		MHz	dBuV	dB	dBuV/m	dBuV/m	dB		
1	*	0.0212	45.16	17.42	62.58	127.64	-65.06	peak	

Test Mode: TX Mode_902.75 MHz

OPEN

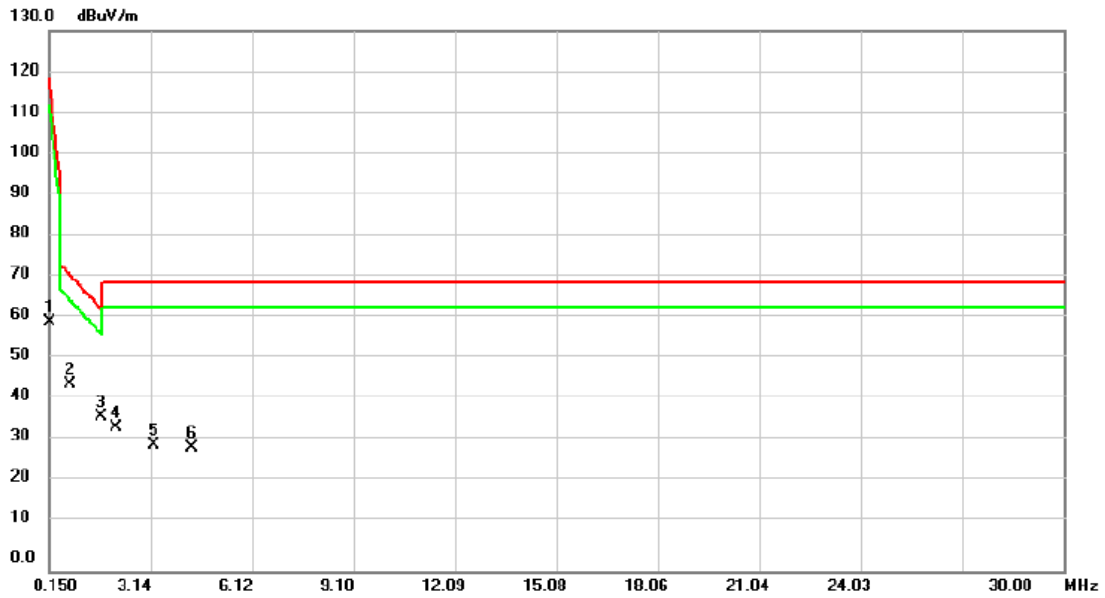

No.	Mk.	Freq. MHz	Reading Level dBuV	Correct Factor dB	Measure- ment dBuV/m	Limit dBuV/m	Margin dB	Detector	Comment
1		0.1500	47.93	12.03	59.96	118.34	-58.38	peak	
2		0.7470	33.04	11.90	44.94	71.51	-26.57	peak	
3	*	1.7020	25.41	11.68	37.09	63.00	-25.91	peak	
4		2.1200	23.06	11.50	34.56	69.54	-34.98	peak	
5		3.2244	19.31	11.13	30.44	69.54	-39.10	peak	
6		4.3290	18.38	11.30	29.68	69.54	-39.86	peak	

Test Mode: TX Mode_902.75 MHz

CLOSE

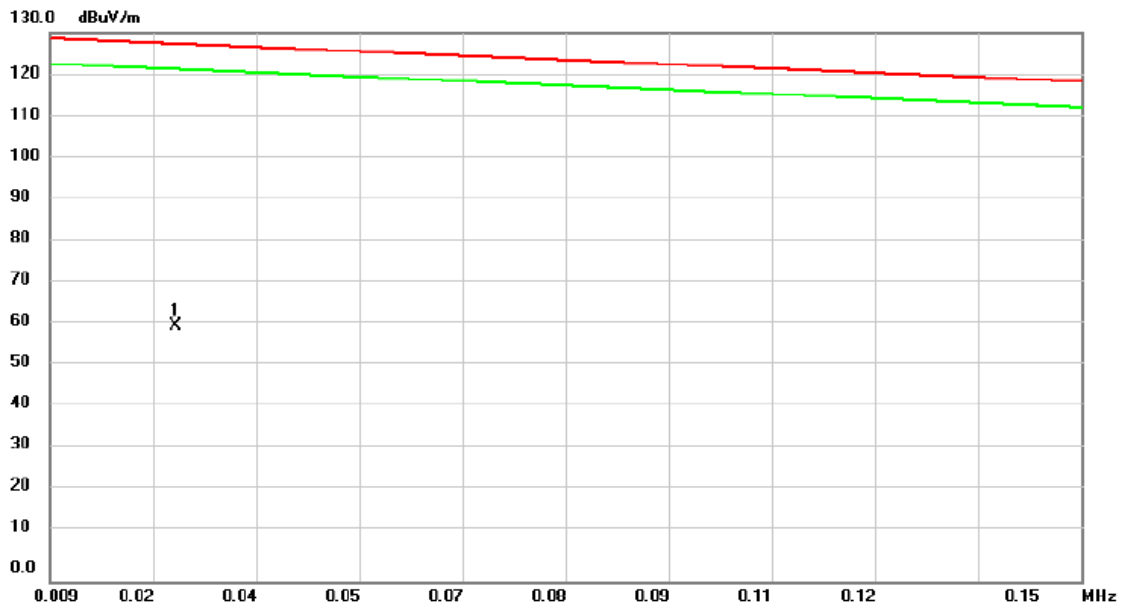

No.	Mk.	Freq. MHz	Reading Level dBuV	Correct Factor dB	Measure- ment dBuV/m	Limit dBuV/m	Margin dB	Detector	Comment
1	*	0.0262	44.44	16.04	60.48	127.28	-66.80	peak	

Test Mode: TX Mode_902.75 MHz

CLOSE

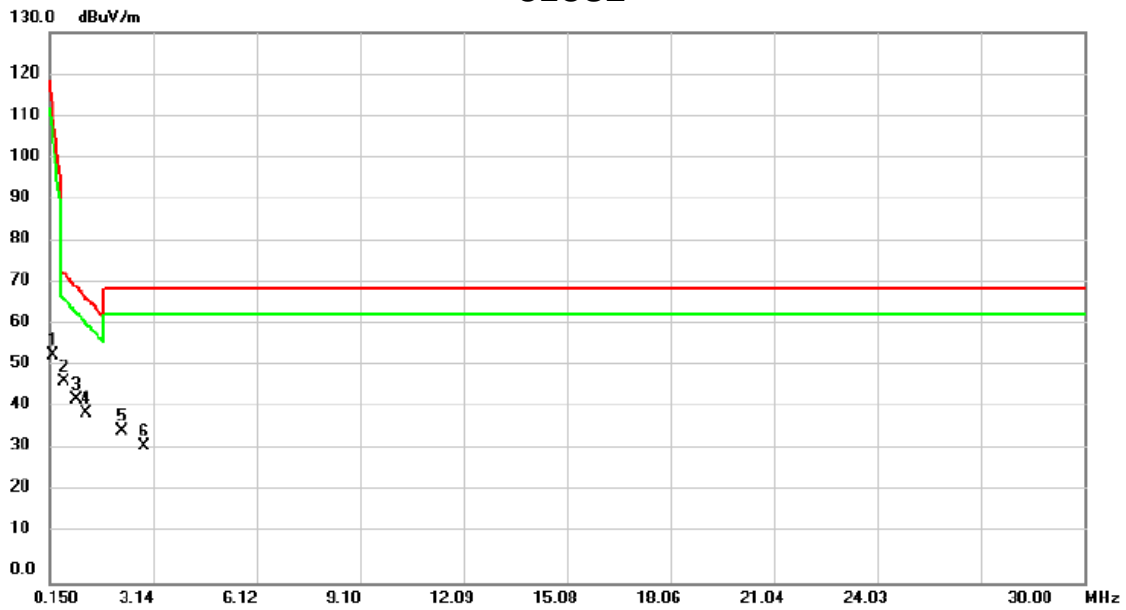

No.	Mk.	Freq. MHz	Reading Level dBuV	Correct Factor dB	Measure- ment dBuV/m	Limit dBuV/m	Margin dB	Detector	Comment
1		0.2691	42.03	11.85	53.88	109.75	-55.87	peak	
2	*	0.5675	35.78	11.83	47.61	73.11	-25.50	peak	
3		0.9261	31.48	11.97	43.45	69.91	-26.46	peak	
4		1.2242	28.18	11.90	40.08	67.26	-27.18	peak	
5		2.2395	24.62	11.44	36.06	69.54	-33.48	peak	
6		2.8664	21.25	11.16	32.41	69.54	-37.13	peak	

Test Mode: TX Mode_915.25 MHz

OPEN

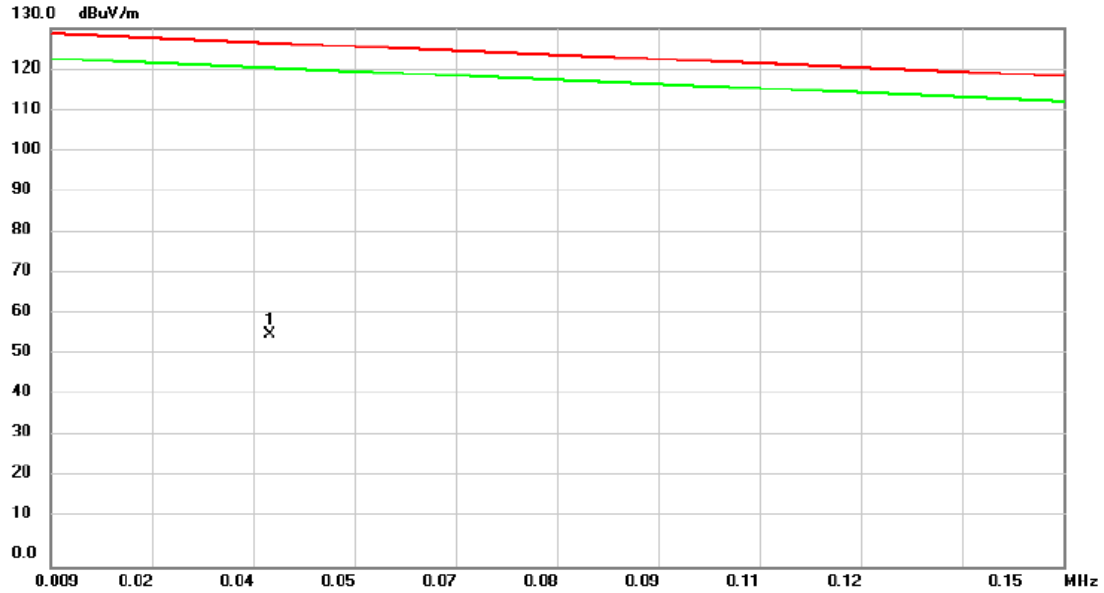

No.	Mk.	Freq. MHz	Reading Level dBuV	Correct Factor dB	Measure- ment dBuV/m	Limit dBuV/m	Margin dB	Detector	Comment
1	*	0.0395	42.02	14.05	56.07	126.32	-70.25	peak	

Test Mode: TX Mode_915.25 MHz

OPEN

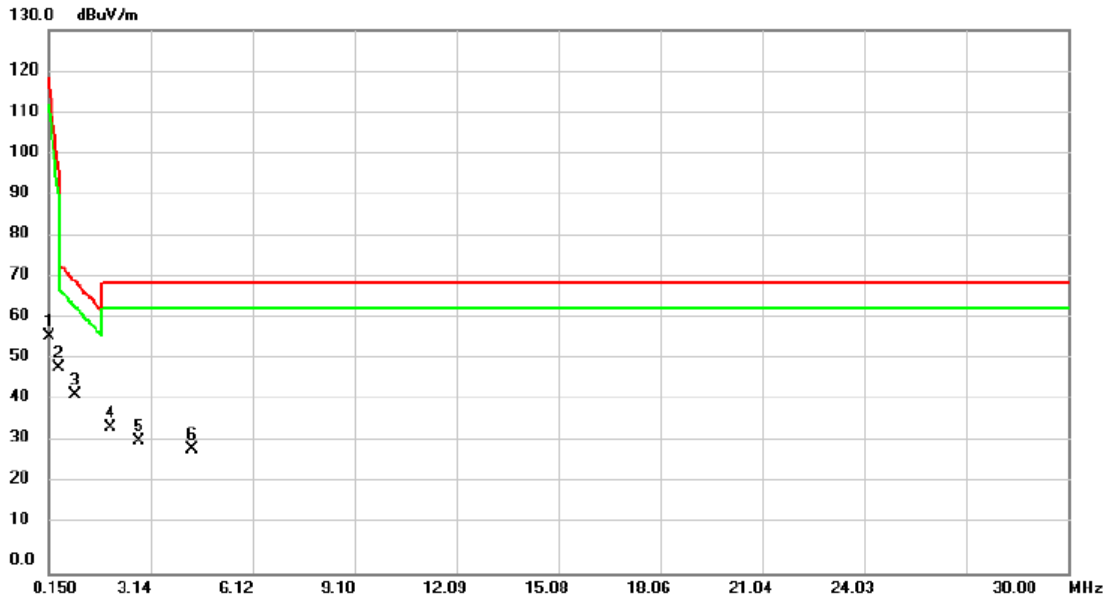

No.	Mk.	Freq. MHz	Reading Level dBuV	Correct Factor dB	Measure- ment dBuV/m	Limit dBuV/m	Margin dB	Detector	Comment
1		0.1800	44.87	11.98	56.85	116.18	-59.33	peak	
2		0.4485	37.41	11.80	49.21	96.80	-47.59	peak	
3	*	0.9261	30.79	11.97	42.76	69.91	-27.15	peak	
4		1.9410	23.39	11.58	34.97	69.54	-34.57	peak	
5		2.8065	20.46	11.19	31.65	69.54	-37.89	peak	
6		4.3290	18.38	11.30	29.68	69.54	-39.86	peak	

Test Mode: TX Mode_915.25 MHz

CLOSE

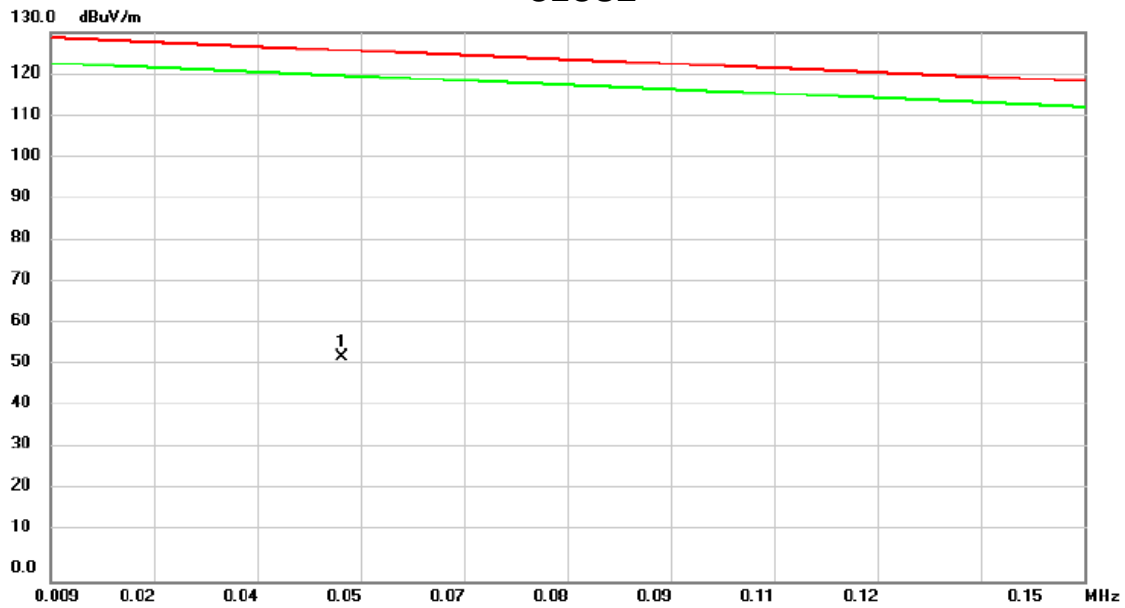

No.	Mk.	Freq.	Reading Level	Correct Factor	Measurement	Limit	Margin	Detector	Comment
		MHz	dBuV	dB	dBuV/m	dBuV/m	dB		
1	*	0.0488	39.87	13.12	52.99	125.65	-72.66	peak	

Test Mode: TX Mode_915.25 MHz

CLOSE

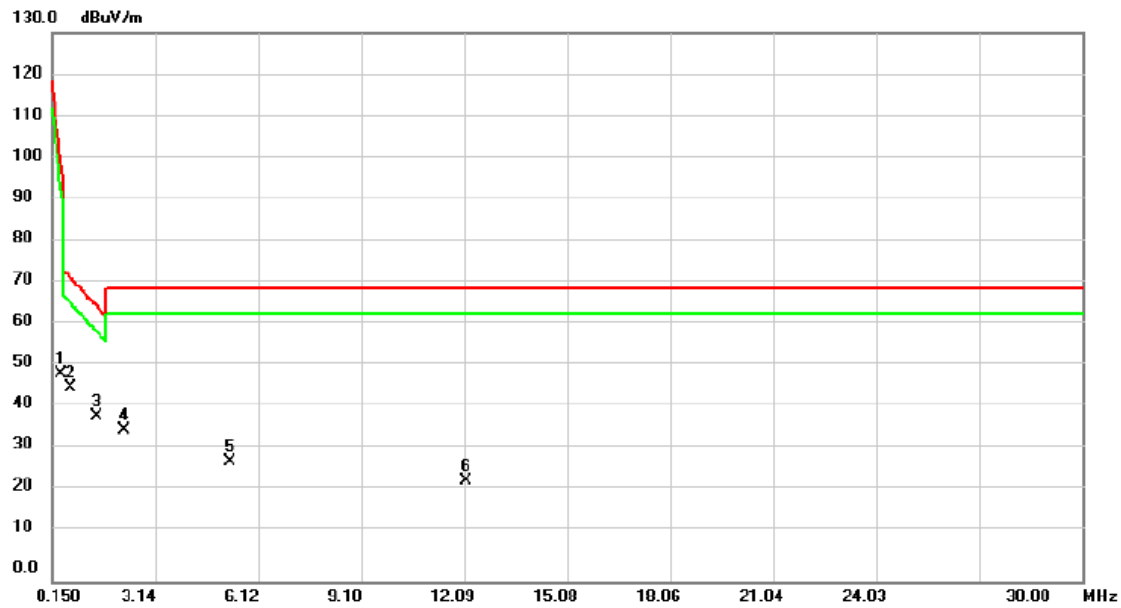

No.	Mk.	Freq. MHz	Reading Level dBuV	Correct Factor dB	Measure- ment dBuV/m	Limit dBuV/m	Margin dB	Detector	Comment
1		0.4187	37.60	11.80	49.40	98.95	-49.55	peak	
2	*	0.6873	34.17	11.87	46.04	72.04	-26.00	peak	
3		1.4334	27.49	11.80	39.29	65.39	-26.10	peak	
4		2.2395	24.62	11.44	36.06	69.54	-33.48	peak	
5		5.2842	16.97	11.39	28.36	69.54	-41.18	peak	
6		12.1493	12.61	11.24	23.85	69.54	-45.69	peak	

Test Mode: TX Mode_927.25 MHz

OPEN

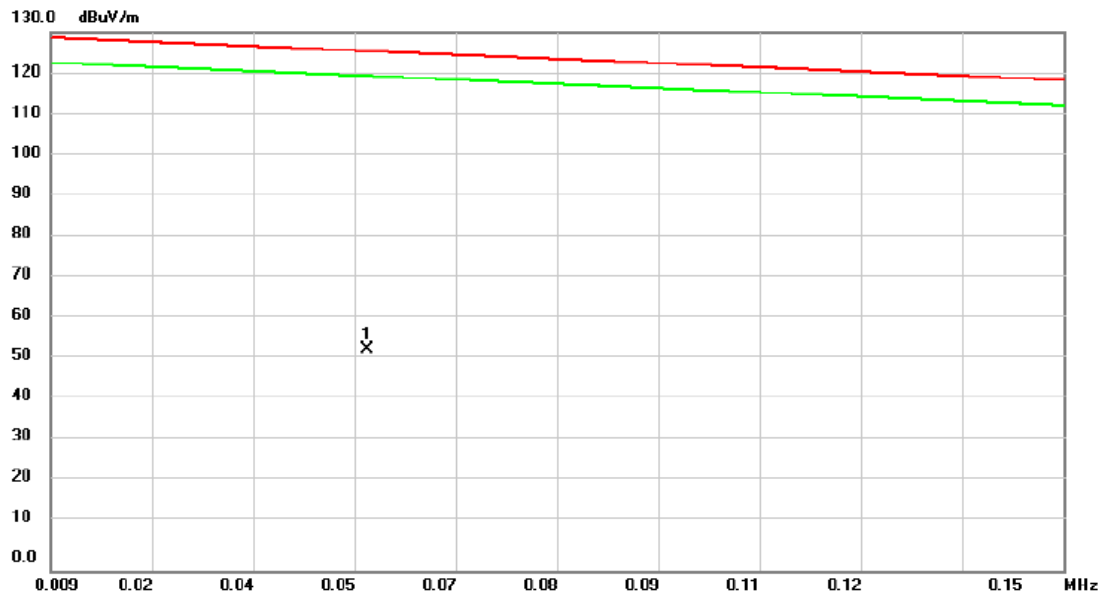

No.	Mk.	Freq. MHz	Reading Level dBuV	Correct Factor dB	Measurement dBuV/m	Limit dBuV/m	Margin dB	Detector	Comment
1	*	0.0530	40.57	12.95	53.52	125.34	-71.82	peak	

Test Mode: TX Mode_927.25 MHz

OPEN

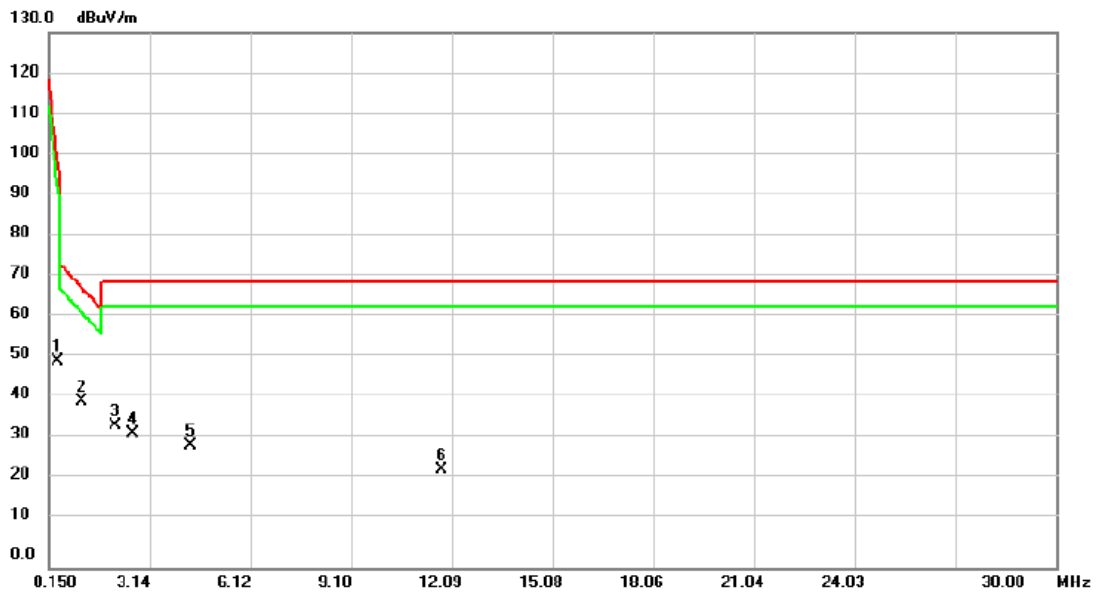

No.	Mk.	Freq. MHz	Reading Level dBuV	Correct Factor dB	Measure- ment dBuV/m	Limit dBuV/m	Margin dB	Detector	Comment
1		0.4187	38.46	11.80	50.26	98.95	-48.69	peak	
2	*	1.1350	28.52	11.94	40.46	68.05	-27.59	peak	
3		2.1200	23.06	11.50	34.56	69.54	-34.98	peak	
4		2.6274	21.29	11.27	32.56	69.54	-36.98	peak	
5		4.3290	18.38	11.30	29.68	69.54	-39.86	peak	
6		11.7911	12.65	11.25	23.90	69.54	-45.64	peak	

Test Mode: TX Mode_927.25 MHz

CLOSE

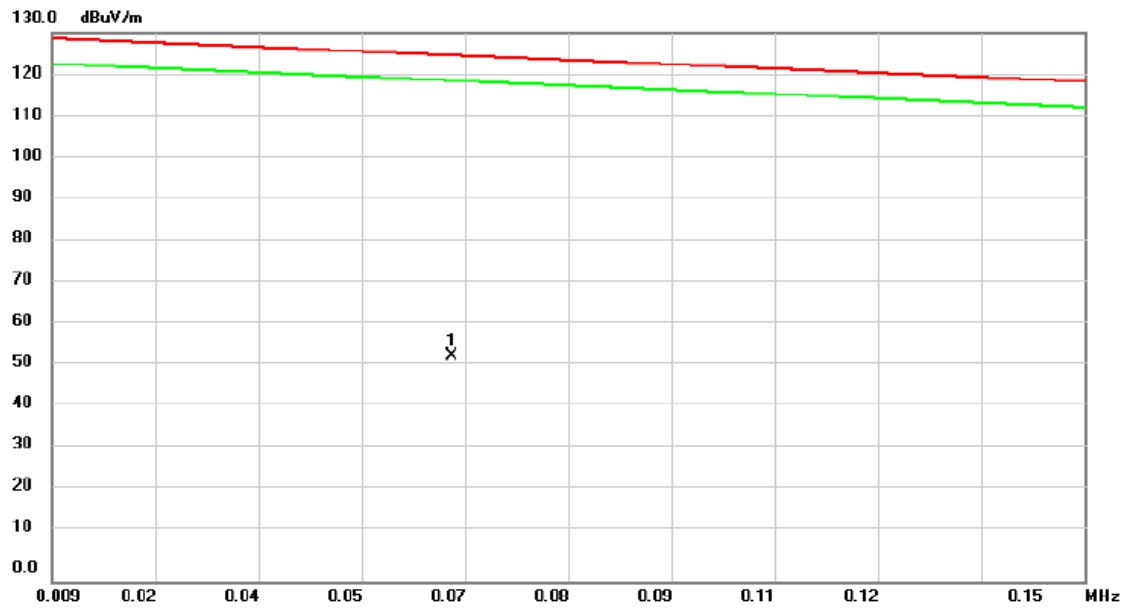

No.	Mk.	Freq.	Reading Level	Correct Factor	Measurement	Limit	Margin	Detector	Comment
		MHz	dBuV	dB	dBuV/m	dBuV/m	dB		
1	*	0.0637	40.61	12.75	53.36	124.57	-71.21	peak	

Test Mode: TX Mode_927.25 MHz

CLOSE

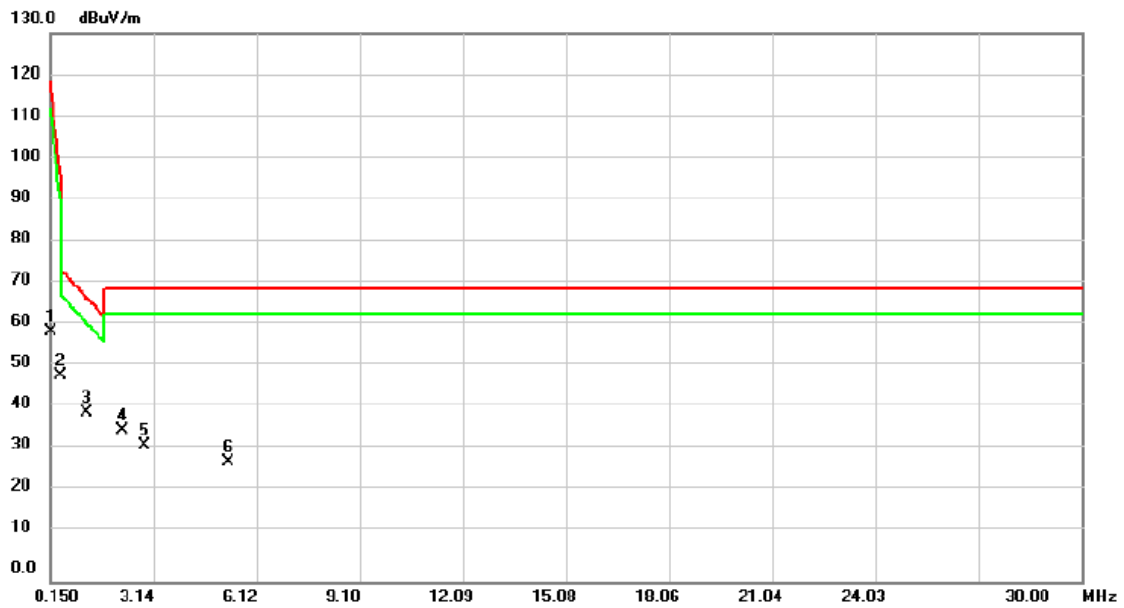

No.	Mk.	Freq. MHz	Reading Level dBuV	Correct Factor dB	Measure- ment dBuV/m	Limit dBuV/m	Margin dB	Detector	Comment
1		0.1500	47.16	12.03	59.19	118.34	-59.15	peak	
2		0.4485	37.06	11.80	48.86	96.80	-47.94	peak	
3	*	1.2242	28.18	11.90	40.08	67.26	-27.18	peak	
4		2.2395	24.62	11.44	36.06	69.54	-33.48	peak	
5		2.8664	21.25	11.16	32.41	69.54	-37.13	peak	
6		5.2842	16.97	11.39	28.36	69.54	-41.18	peak	

ATTACHMENT C - RADIATED EMISSION (30MHZ TO 1000MHZ)

Test Mode: TX Mode_902.75 MHz

Vertical

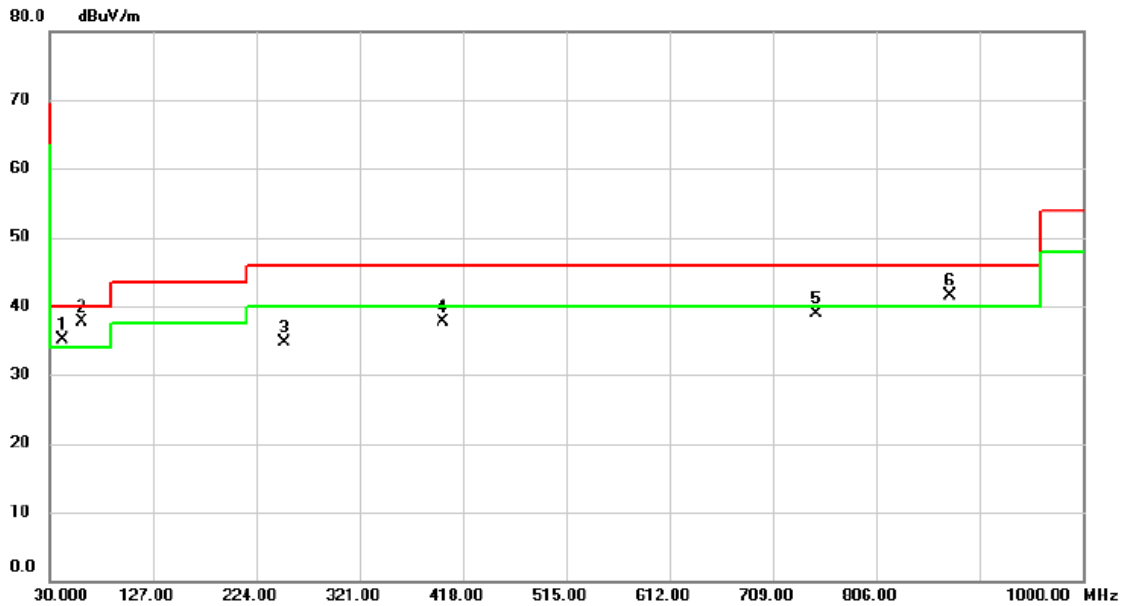

No.	Mk.	Freq. MHz	Reading Level dBuV	Correct Factor dB	Measure- ment dBuV/m	Limit dBuV/m	Margin dB	Detector	Comment
1	!	42.6100	43.51	-8.45	35.06	40.00	-4.94	peak	
2	*	60.0700	46.55	-8.84	37.71	40.00	-2.29	peak	
3		250.1900	43.98	-9.20	34.78	46.00	-11.22	peak	
4		398.6000	42.71	-4.94	37.77	46.00	-8.23	peak	
5		749.7400	36.53	2.33	38.86	46.00	-7.14	peak	
6	!	874.8700	37.37	4.10	41.47	46.00	-4.53	peak	

Test Mode: TX Mode_902.75 MHz

Horizontal

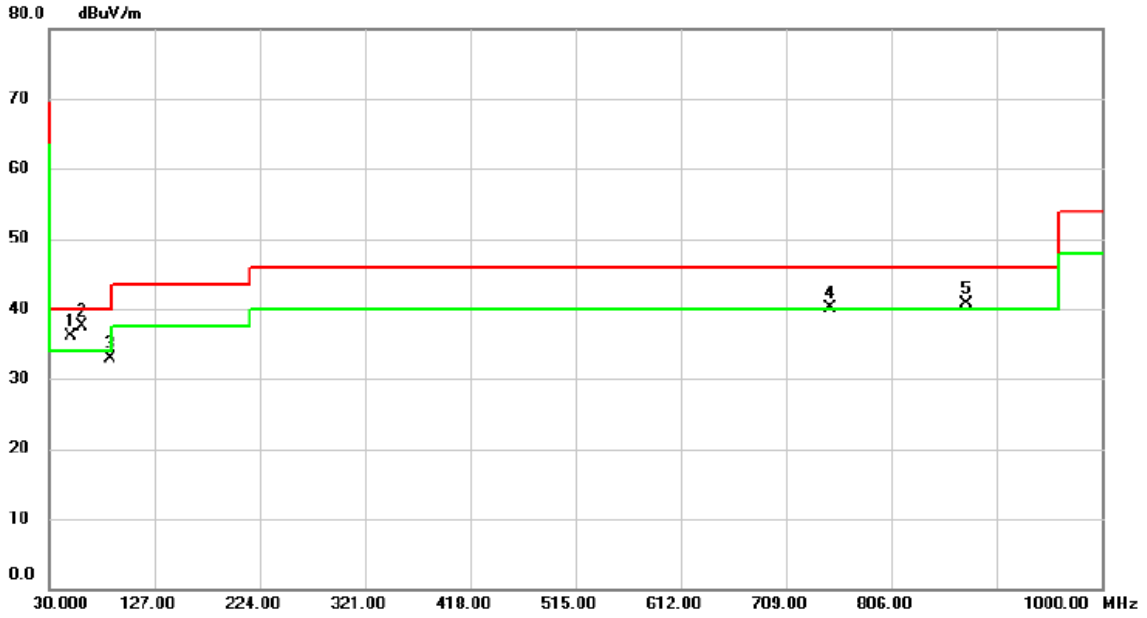

No.	Mk.	Freq. MHz	Reading Level dBuV	Correct Factor dB	Measure- ment dBuV/m	Limit dBuV/m	Margin dB	Detector	Comment
1	!	49.4000	44.36	-8.25	36.11	40.00	-3.89	peak	
2	*	60.0700	46.29	-8.84	37.45	40.00	-2.55	peak	
3		86.2600	45.95	-13.03	32.92	40.00	-7.08	peak	
4	!	749.7400	37.75	2.33	40.08	46.00	-5.92	peak	
5	!	874.8700	36.51	4.10	40.61	46.00	-5.39	peak	

Test Mode: TX Mode_912.25 MHz

Vertical

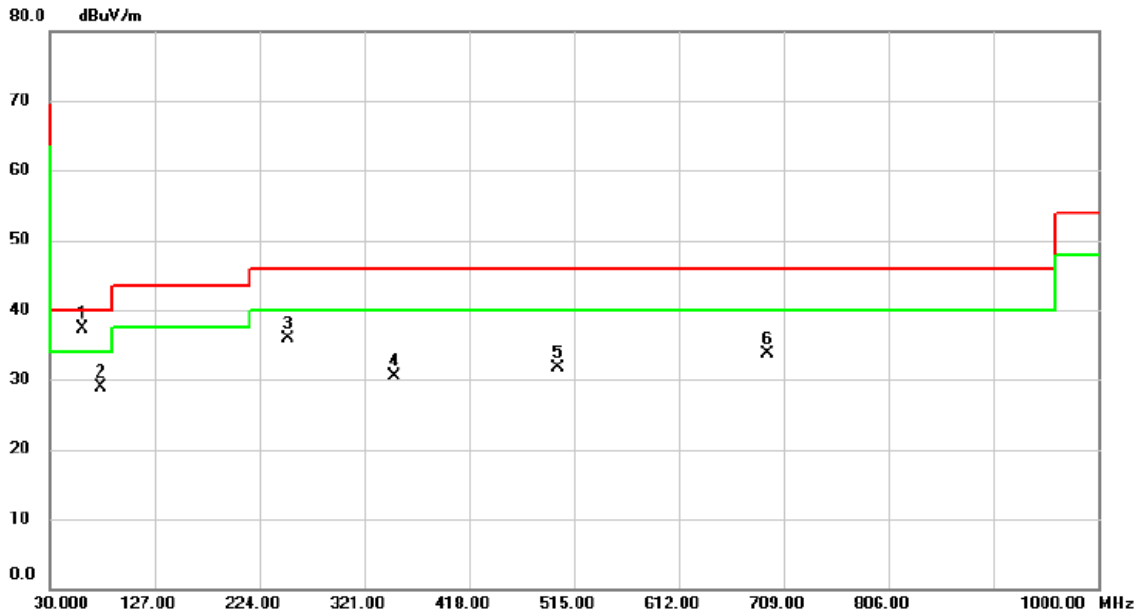

No.	Mk.	Freq. MHz	Reading Level dBuV	Correct Factor dB	Measure- ment dBuV/m	Limit dBuV/m	Margin dB	Detector	Comment
1	*	60.0700	46.23	-8.84	37.39	40.00	-2.61	peak	
2		76.5600	40.54	-11.62	28.92	40.00	-11.08	peak	
3		250.1900	45.18	-9.20	35.98	46.00	-10.02	peak	
4		349.1300	36.42	-6.01	30.41	46.00	-15.59	peak	
5		500.4500	34.36	-2.64	31.72	46.00	-14.28	peak	
6		693.4800	32.60	1.15	33.75	46.00	-12.25	peak	

Test Mode: TX Mode_912.25 MHz

Horizontal

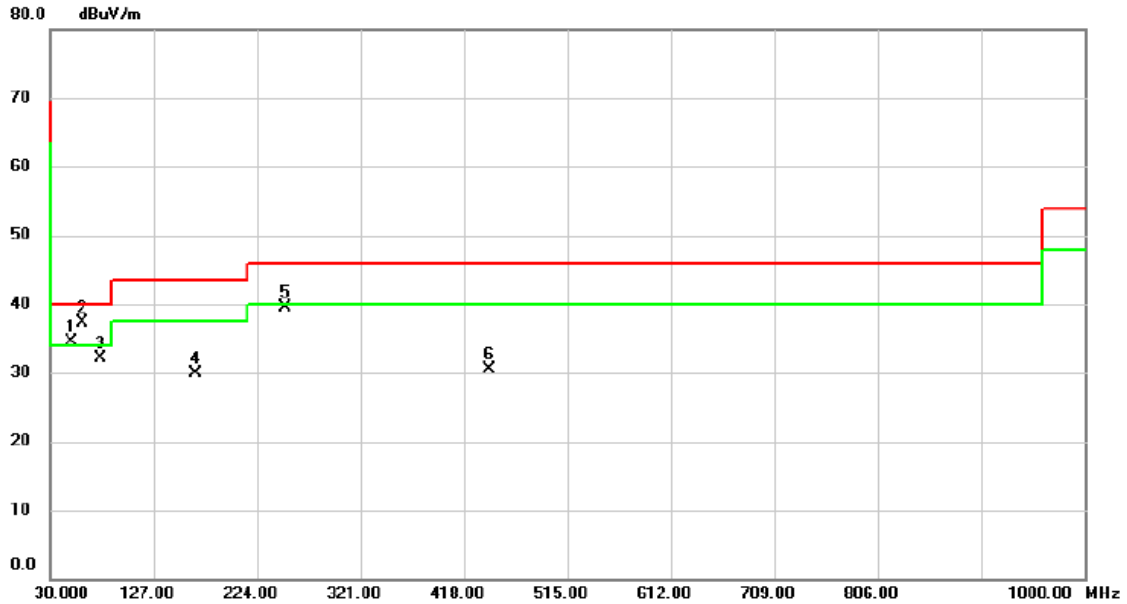

No.	Mk.	Freq. MHz	Reading Level dBuV	Correct Factor dB	Measure- ment dBuV/m	Limit dBuV/m	Margin dB	Detector	Comment
1	I	50.3700	42.69	-8.28	34.41	40.00	-5.59	peak	
2	*	60.0700	46.23	-8.84	37.39	40.00	-2.61	peak	
3		76.5600	43.63	-11.62	32.01	40.00	-7.99	peak	
4		165.8000	38.67	-8.73	29.94	43.50	-13.56	peak	
5		250.1900	48.65	-9.20	39.45	46.00	-6.55	peak	
6		441.2800	34.34	-3.75	30.59	46.00	-15.41	peak	

Test Mode: TX Mode_927.25 MHz

Vertical

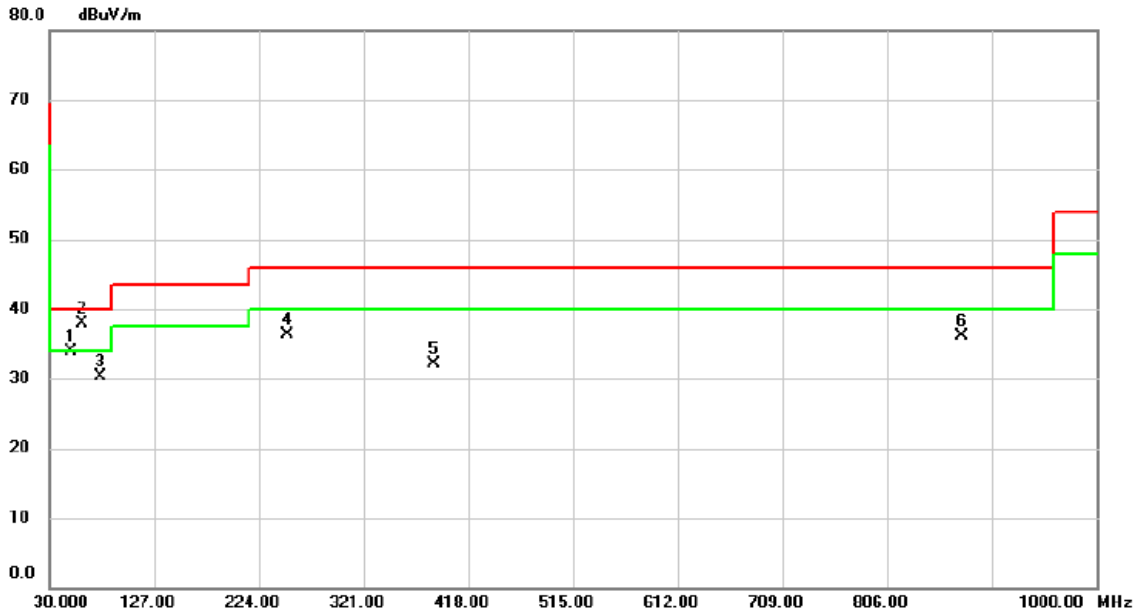

No.	Mk.	Freq. MHz	Reading Level dBuV	Correct Factor dB	Measure- ment dBuV/m	Limit dBuV/m	Margin dB	Detector	Comment
1		49.4000	42.17	-8.25	33.92	40.00	-6.08	peak	
2	*	60.0700	46.73	-8.84	37.89	40.00	-2.11	peak	
3		76.5600	41.89	-11.62	30.27	40.00	-9.73	peak	
4		250.1900	45.42	-9.20	36.22	46.00	-9.78	peak	
5		385.9900	37.40	-5.22	32.18	46.00	-13.82	peak	
6		874.8700	32.09	4.10	36.19	46.00	-9.81	peak	

Test Mode: TX Mode_927.25 MHz

Horizontal

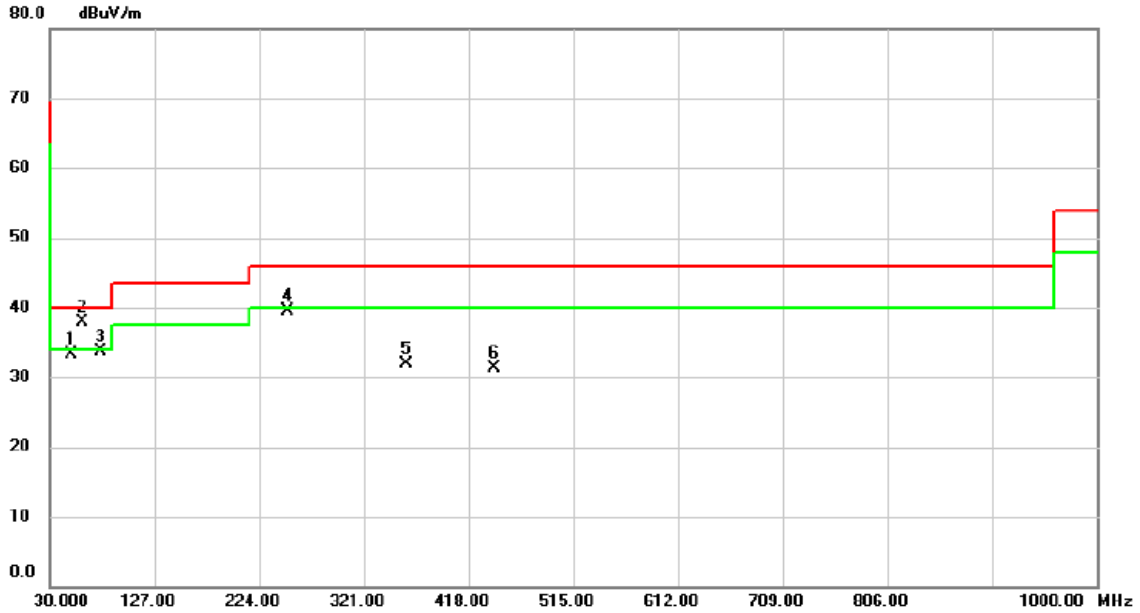

No.	Mk.	Freq. MHz	Reading Level dBuV	Correct Factor dB	Measure- ment dBuV/m	Limit dBuV/m	Margin dB	Detector	Comment
1		49.4000	41.54	-8.25	33.29	40.00	-6.71	peak	
2	*	60.0700	46.73	-8.84	37.89	40.00	-2.11	peak	
3		76.5600	45.35	-11.62	33.73	40.00	-6.27	peak	
4		250.1900	48.63	-9.20	39.43	46.00	-6.57	peak	
5		359.8000	37.77	-5.77	32.00	46.00	-14.00	peak	
6		441.2800	35.14	-3.75	31.39	46.00	-14.61	peak	

ATTACHMENT D - RADIATED EMISSION (ABOVE 1000MHZ)

Orthogonal Axis :	X
Test Mode :	TX 902.75MHz _CH00

Vertical

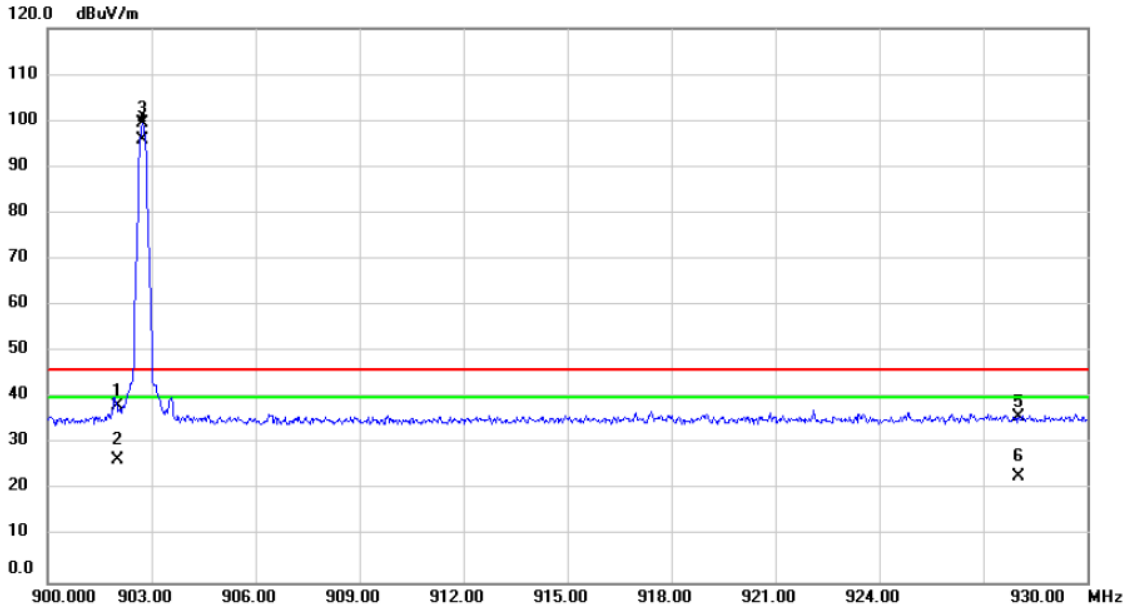

No.	Mk.	Freq. MHz	Reading Level dBuV	Correct Factor dB	Measure- ment dBuV/m	Limit dBuV/m	Margin dB	Detector	Comment
1		902.0000	6.53	31.65	38.18	79.37	-41.19	peak	
2		902.0000	-5.14	31.65	26.51	75.73	-49.22	AVG	
3	*	902.7500	67.71	31.66	99.37	46.00	53.37	peak	No Limit
4	X	902.7500	64.07	31.66	95.73	46.00	49.73	AVG	No Limit
5		928.0000	3.80	32.02	35.82	79.37	-40.55	peak	
6		928.0000	-9.10	32.02	22.92	75.73	-52.81	AVG	

Orthogonal Axis :	X
Test Mode :	TX 902.75MHz _CH00

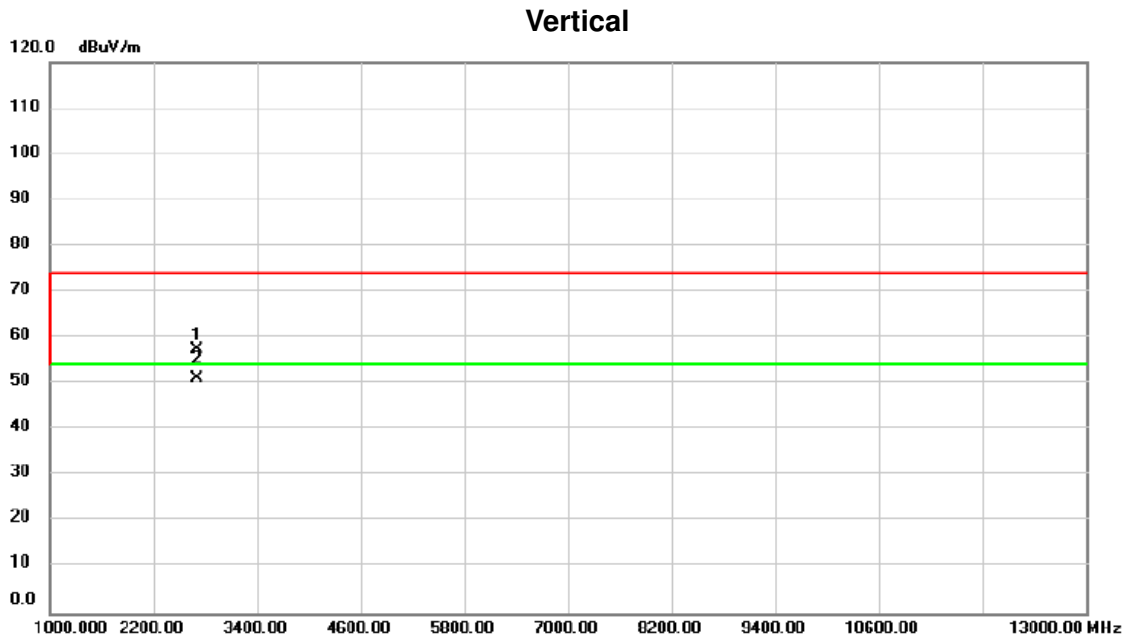

No.	Mk.	Freq. MHz	Reading Level dBuV	Correct Factor dB	Measure- ment dBuV/m	Limit dBuV/m	Margin dB	Detector	Comment
1		2704.000	72.50	-15.04	57.46	74.00	-16.54	peak	
2	*	2704.000	66.12	-15.04	51.08	54.00	-2.92	AVG	

Orthogonal Axis :	X
Test Mode :	TX 902.75MHz _CH00

Horizontal

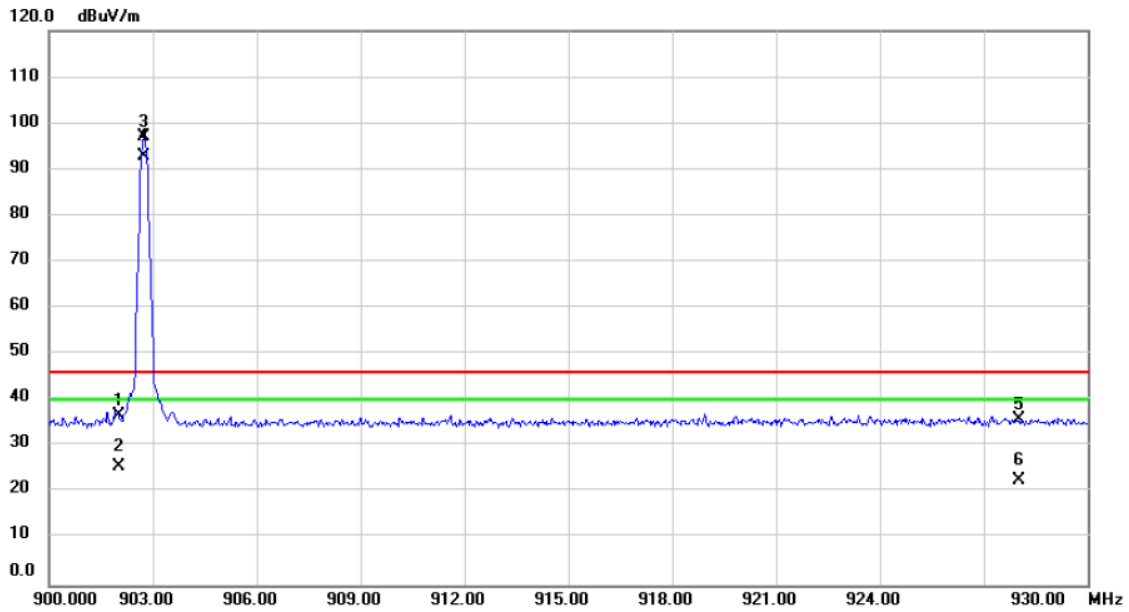

No.	Mk.	Freq. MHz	Reading Level dBuV	Correct Factor dB	Measure- ment dBuV/m	Limit dBuV/m	Margin dB	Detector	Comment
1		902.0000	5.02	31.65	36.67	77.11	-40.44	peak	
2		902.0000	-5.98	31.65	25.67	72.87	-47.2	AVG	
3	*	902.7500	65.45	31.66	97.11	46.00	51.11	peak	No Limit
4	X	902.7500	61.21	31.66	92.87	46.00	46.87	AVG	No Limit
5		928.0000	3.94	32.02	35.96	77.11	-41.15	peak	
6		928.0000	-9.24	32.02	22.78	72.87	-50.09	AVG	

Orthogonal Axis :	X
Test Mode :	TX 902.75MHz _CH00

Horizontal

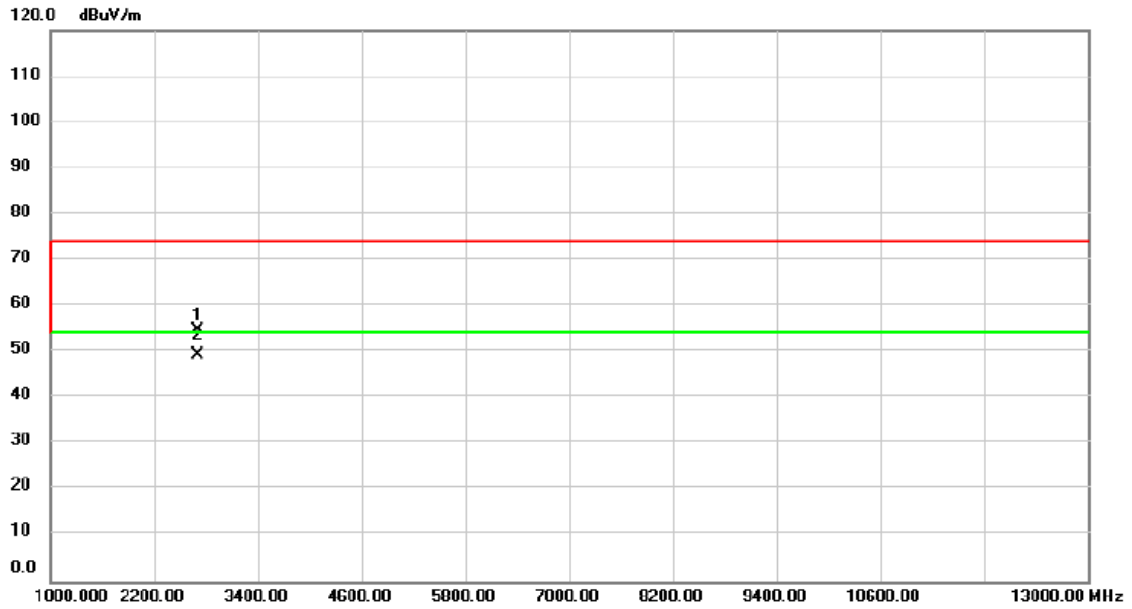

No.	Mk.	Freq. MHz	Reading Level dBuV	Correct Factor dB	Measure- ment dBuV/m	Limit dBuV/m	Margin dB	Detector	Comment
1		2704.000	69.91	-15.04	54.87	74.00	-19.13	peak	
2	*	2704.000	64.40	-15.04	49.36	54.00	-4.64	AVG	

Orthogonal Axis :	X
Test Mode :	TX 915.25MHz _CH02

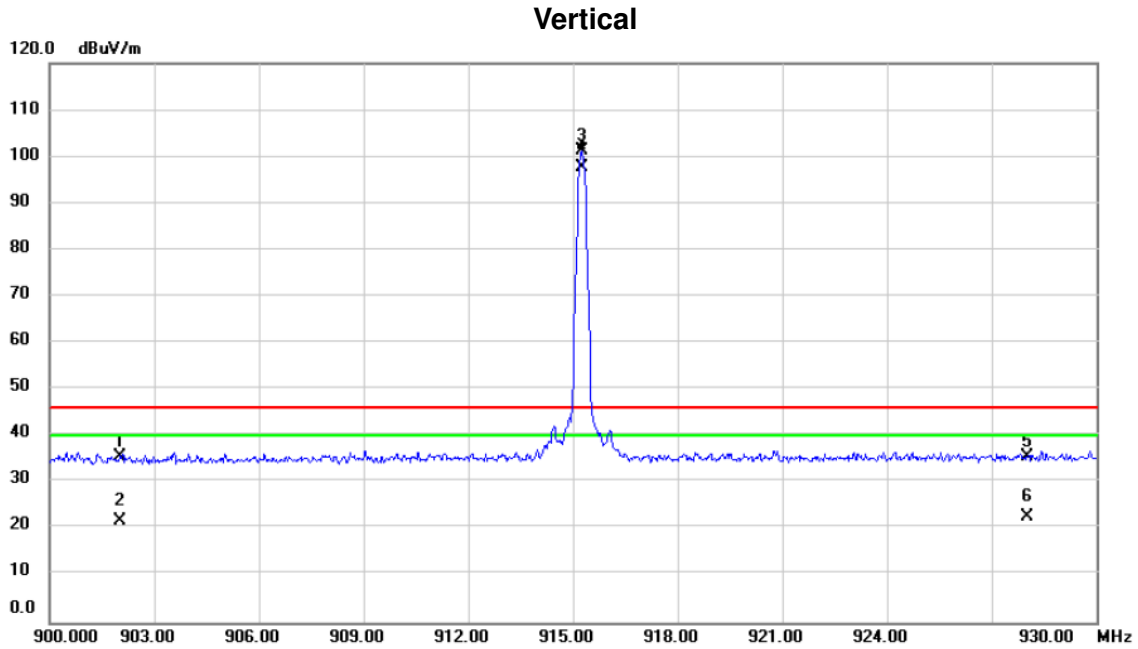

No.	Mk.	Freq. MHz	Reading Level dBuV	Correct Factor dB	Measure- ment dBuV/m	Limit dBuV/m	Margin dB	Detector	Comment
1		902.0000	4.04	31.65	35.69	81.14	-45.45	peak	
2		902.0000	-9.77	31.65	21.88	77.79	-55.91	AVG	
3	*	915.2500	69.30	31.84	101.14	46.00	55.14	peak	No Limit
4	X	915.2500	65.95	31.84	97.79	46.00	51.79	AVG	No Limit
5		928.0000	3.57	32.02	35.59	81.14	-45.55	peak	
6		928.0000	-9.43	32.02	22.59	77.79	-55.2	AVG	

Orthogonal Axis :	X
Test Mode :	TX 915.25MHz _CH02

Vertical

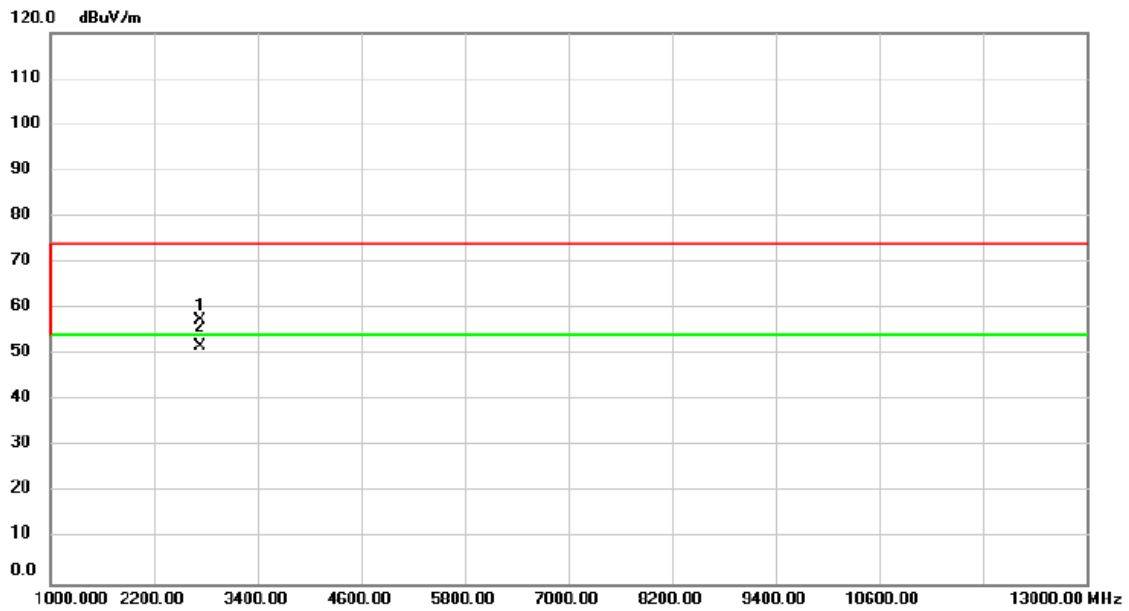

No.	Mk.	Freq. MHz	Reading Level dBuV	Correct Factor dB	Measure- ment dBuV/m	Limit dBuV/m	Margin dB	Detector	Comment
1		2740.000	72.20	-14.89	57.31	74.00	-16.69	peak	
2	*	2740.000	66.68	-14.89	51.79	54.00	-2.21	AVG	

Orthogonal Axis :	X
Test Mode :	TX 915.25MHz _CH02

Horizontal

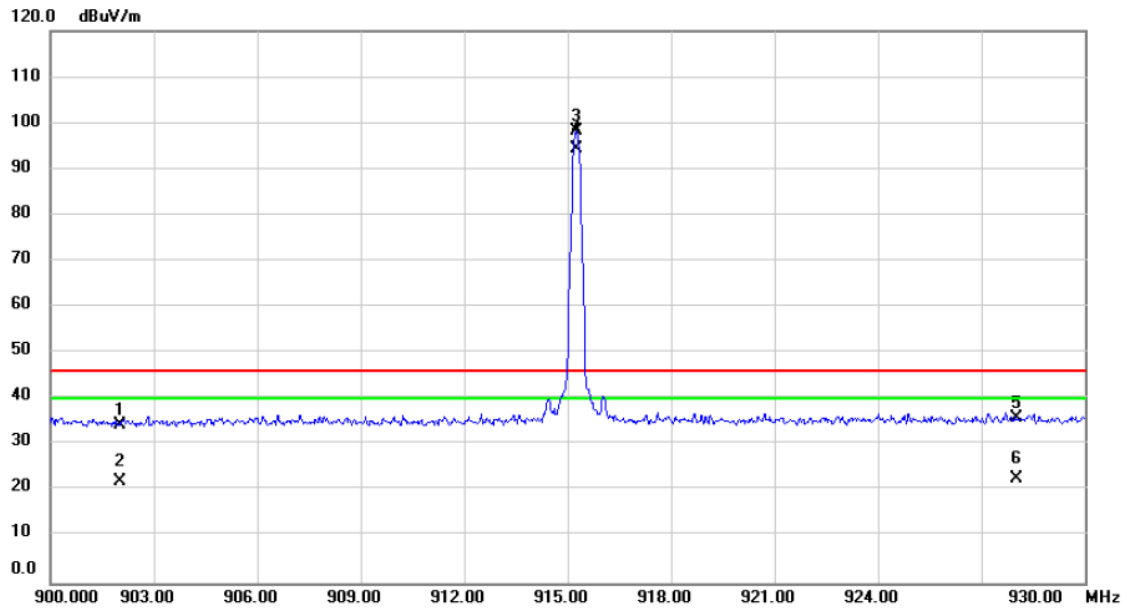

No.	Mk.	Freq. MHz	Reading Level dBuV	Correct Factor dB	Measure- ment dBuV/m	Limit dBuV/m	Margin dB	Detector	Comment
1		902.0000	2.75	31.65	34.40	78.31	-43.91	peak	
2	X	902.0000	-9.46	31.65	22.19	74.39	-52.2	AVG	
3	*	915.2500	66.47	31.84	98.31	46.00	52.31	peak	No Limit
4	X	915.2500	62.55	31.84	94.39	46.00	48.39	AVG	No Limit
5		928.0000	3.77	32.02	35.79	78.31	-42.52	peak	
6	X	928.0000	-9.40	32.02	22.62	74.39	-51.77	AVG	

Orthogonal Axis :	X
Test Mode :	TX 915.25MHz _CH02

Horizontal

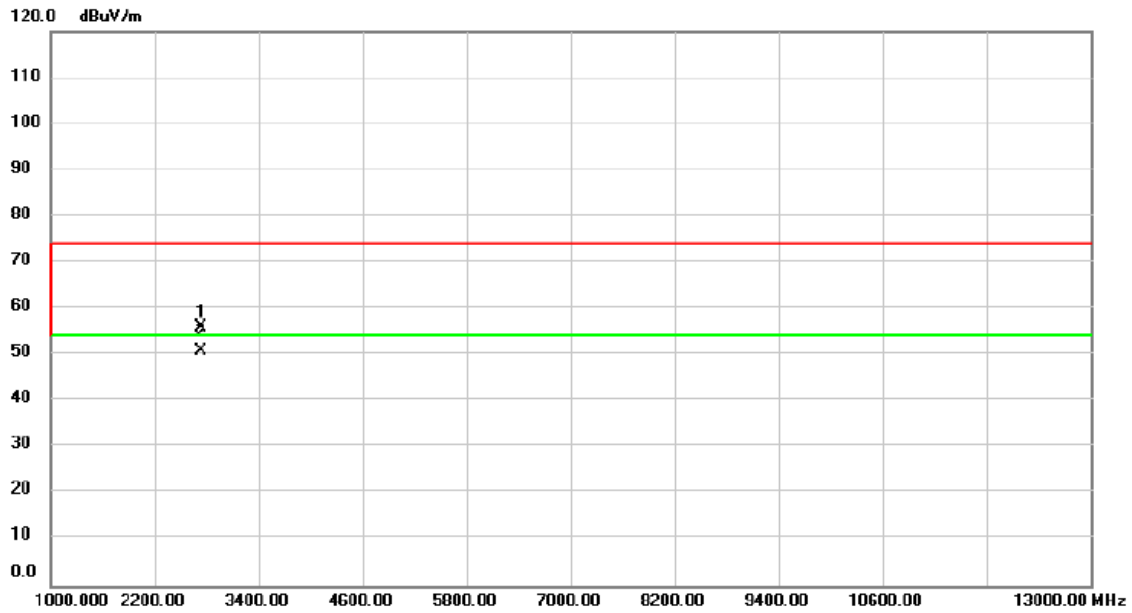

No.	Mk.	Freq. MHz	Reading Level dBuV	Correct Factor dB	Measure- ment dBuV/m	Limit dBuV/m	Margin dB	Detector	Comment
1		2740.000	70.85	-14.89	55.96	74.00	-18.04	peak	
2	*	2740.000	65.86	-14.89	50.97	54.00	-3.03	AVG	

Orthogonal Axis :	X
Test Mode :	TX 927.25MHz _CH03

Vertical

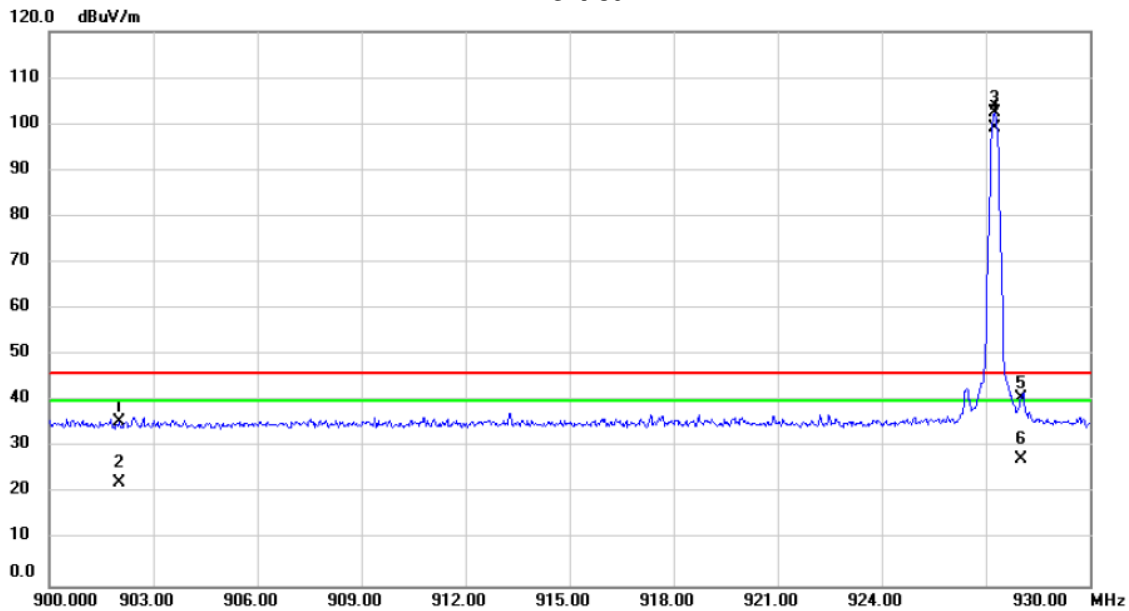

No.	Mk.	Freq. MHz	Reading Level dBuV	Correct Factor dB	Measure- ment dBuV/m	Limit dBuV/m	Margin dB	Detector	Comment
1		902.0000	3.81	31.65	35.46	82.40	-46.94	peak	
2		902.0000	-9.44	31.65	22.21	79.02	-56.81	AVG	
3	*	927.2500	70.39	32.01	102.40	46.00	56.40	peak	No Limit
4	X	927.2500	67.01	32.01	99.02	46.00	53.02	AVG	No Limit
5	!	928.0000	8.78	32.02	40.80	82.40	-41.6	peak	
6		928.0000	-4.71	32.02	27.31	79.02	-51.71	AVG	

Orthogonal Axis :	X
Test Mode :	TX 927.25MHz _CH03

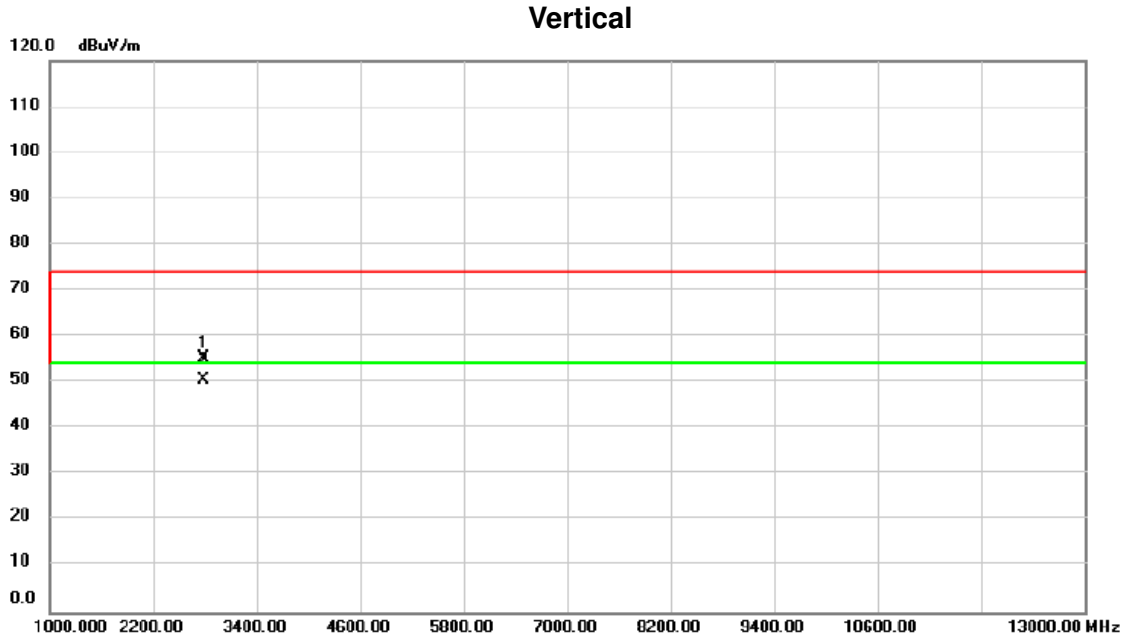

No.	Mk.	Freq. MHz	Reading Level dBuV	Correct Factor dB	Measure- ment dBuV/m	Limit dBuV/m	Margin dB	Detector	Comment
1		2776.000	70.22	-14.74	55.48	74.00	-18.52	peak	
2	*	2776.000	65.22	-14.74	50.48	54.00	-3.52	AVG	

Orthogonal Axis :	X
Test Mode :	TX 927.25MHz _CH03

Horizontal

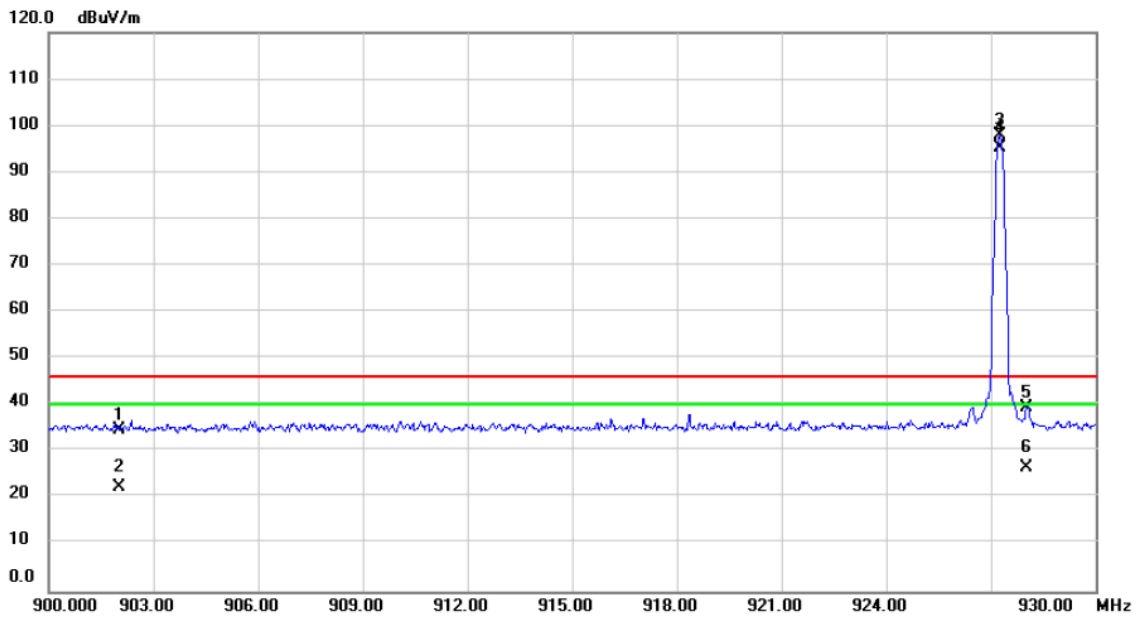

No.	Mk.	Freq. MHz	Reading Level dBuV	Correct Factor dB	Measure- ment dBuV/m	Limit dBuV/m	Margin dB	Detector	Comment
1		902.0000	2.88	31.65	34.53	78.01	-43.48	peak	
2		902.0000	-9.42	31.65	22.23	75.13	-52.9	AVG	
3	*	927.2500	66.00	32.01	98.01	46.00	52.01	peak	No Limit
4	X	927.2500	63.12	32.01	95.13	46.00	49.13	AVG	No Limit
5		928.0000	7.55	32.02	39.57	78.01	-38.44	peak	
6		928.0000	-5.42	32.02	26.60	75.13	-48.53	AVG	

Orthogonal Axis :	X
Test Mode :	TX 927.25MHz _CH03

Horizontal

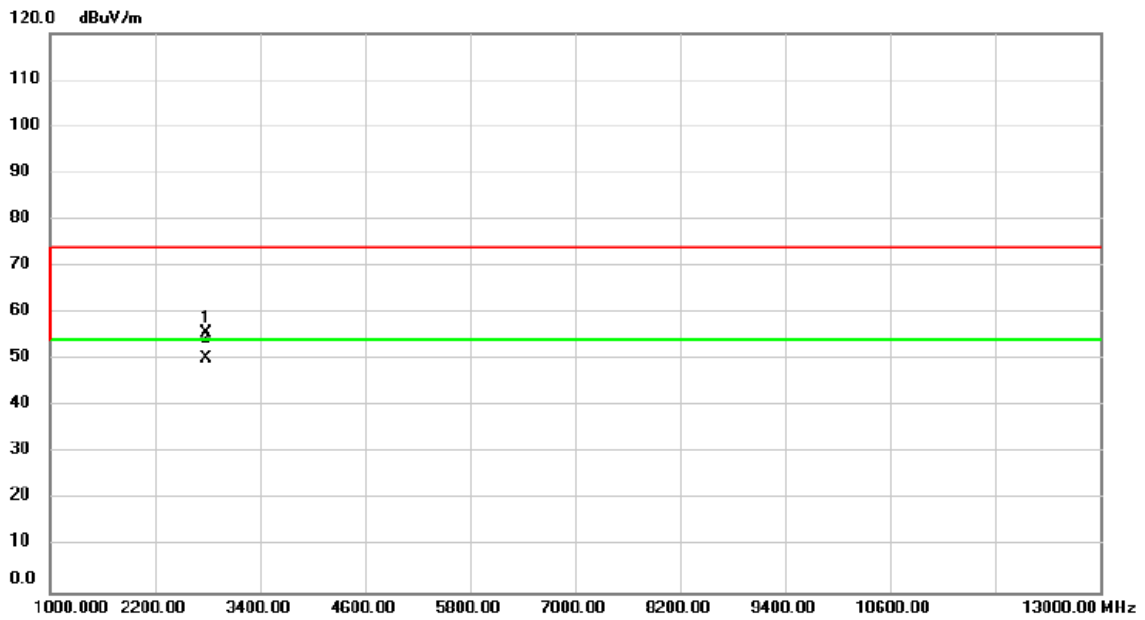

No.	Mk.	Freq. MHz	Reading Level dBuV	Correct Factor dB	Measure- ment dBuV/m	Limit dBuV/m	Margin dB	Detector	Comment
1		2776.000	70.33	-14.74	55.59	74.00	-18.41	peak	
2	*	2776.000	64.89	-14.74	50.15	54.00	-3.85	AVG	

ATTACHMENT E - NUMBER OF HOPPING CHANNEL

Test Mode 902MHz
Number of RFID 03

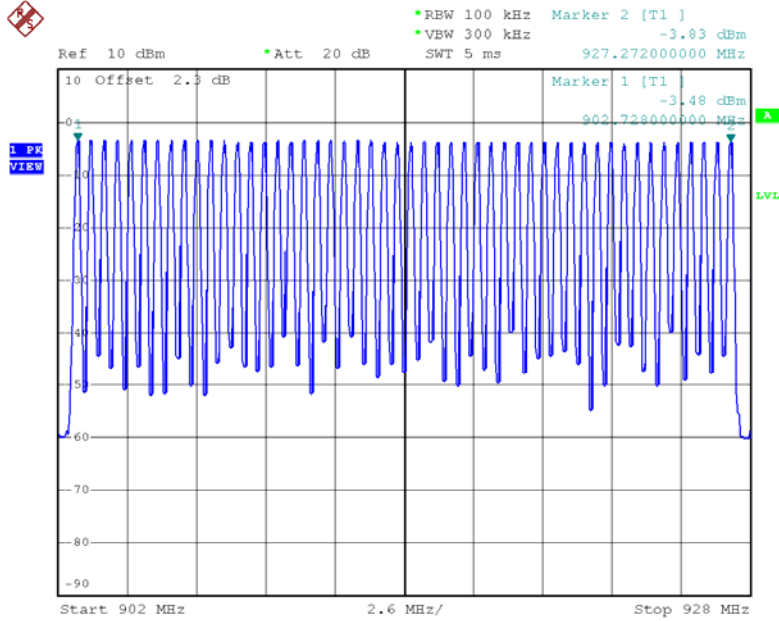

Date: 17.JUL.2016 14:59:35

ATTACHMENT F - AVERAGE TIME OF OCCUPANCY

Test Mode :	TX Mode
-------------	---------

Data Packet	Frequency (MHz)	Pulse Duration (ms)	Dwell Time (s)	Limits (s)	Test Result
-	902.75	0.4000	0.0427	0.4000	Complies
-	915.25	0.4000	0.0427	0.4000	Complies
-	927.25	0.3980	0.0425	0.4000	Complies

CH01_1

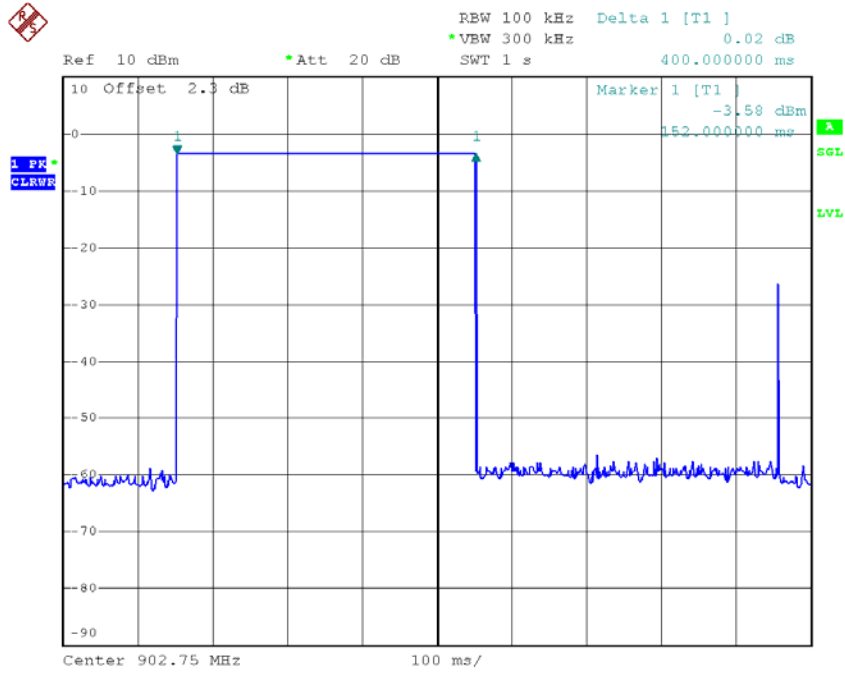

Date: 17.JUL.2016 13:31:21

CH01_2

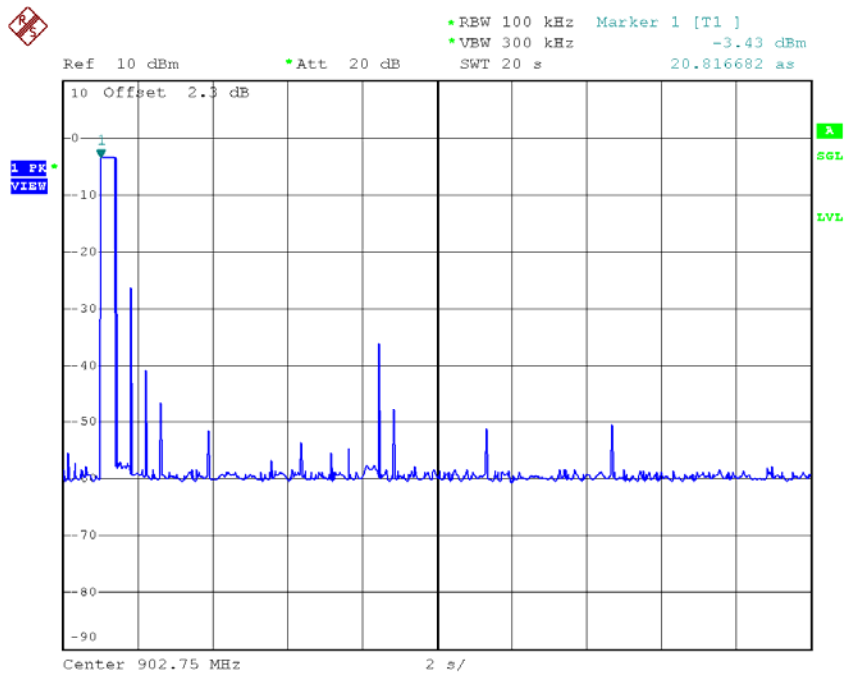

Date: 17.JUL.2016 13:36:45

CH02_1

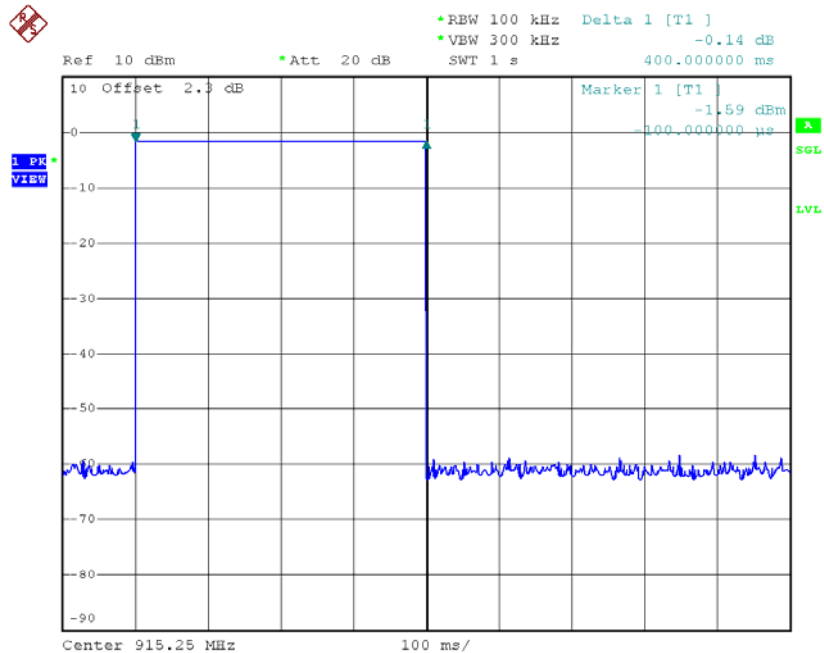

Date: 17.JUL.2016 14:11:49

CH02_2

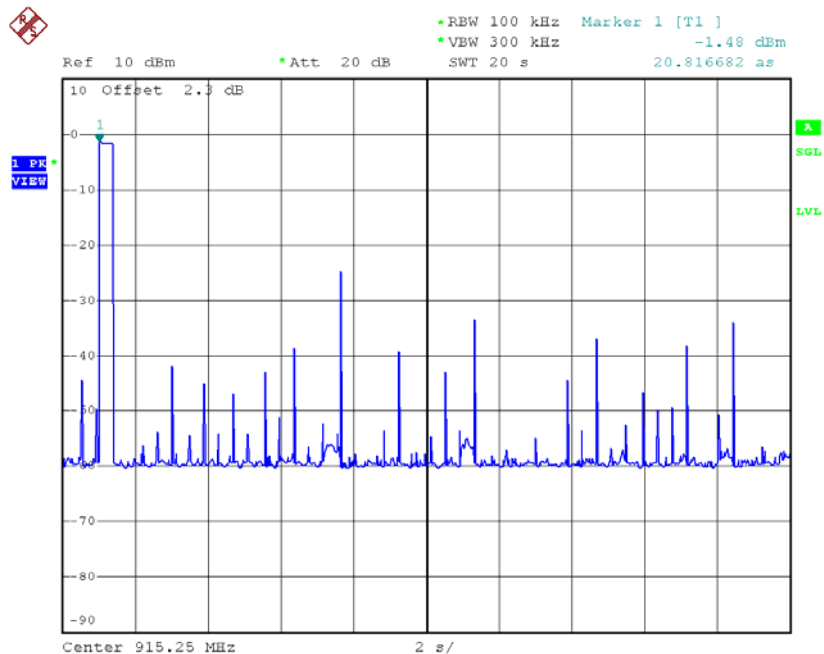

Date: 17.JUL.2016 13:52:52

CH02_3

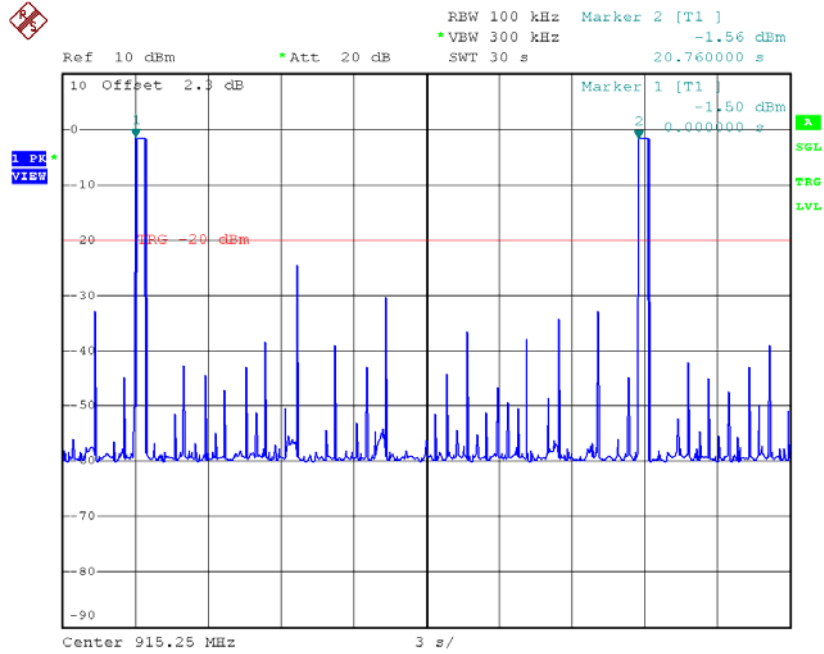

Date: 17.JUL.2016 14:16:51

CH03_1

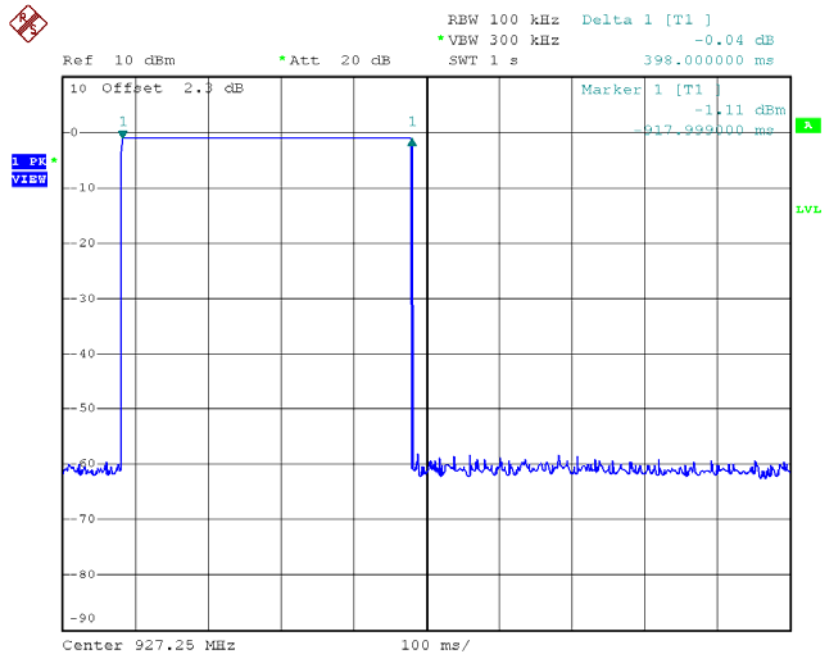

Date: 17.JUL.2016 14:08:27

CH03_2

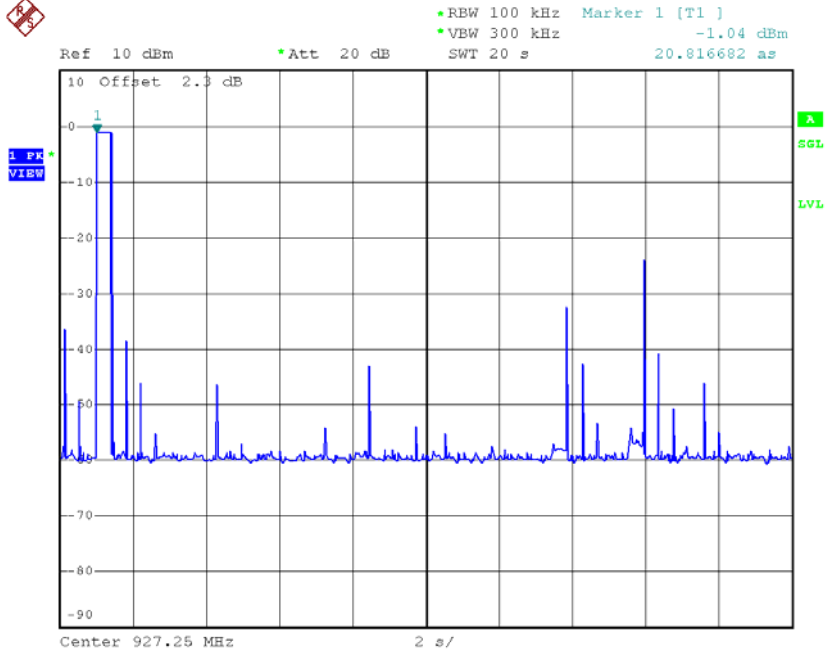

Date: 17.JUL.2016 13:55:32

ATTACHMENT G - HOPPING CHANNEL SEPARATION MEASUREMENT

Test Mode : TX Mode

Frequency (MHz)	Channel Separation (MHz)	2/3 of 20dB Bandwidth (MHz)	Test Result
902.75	0.502	0.056	Complies
915.25	0.502	0.056	Complies
927.25	0.502	0.056	Complies

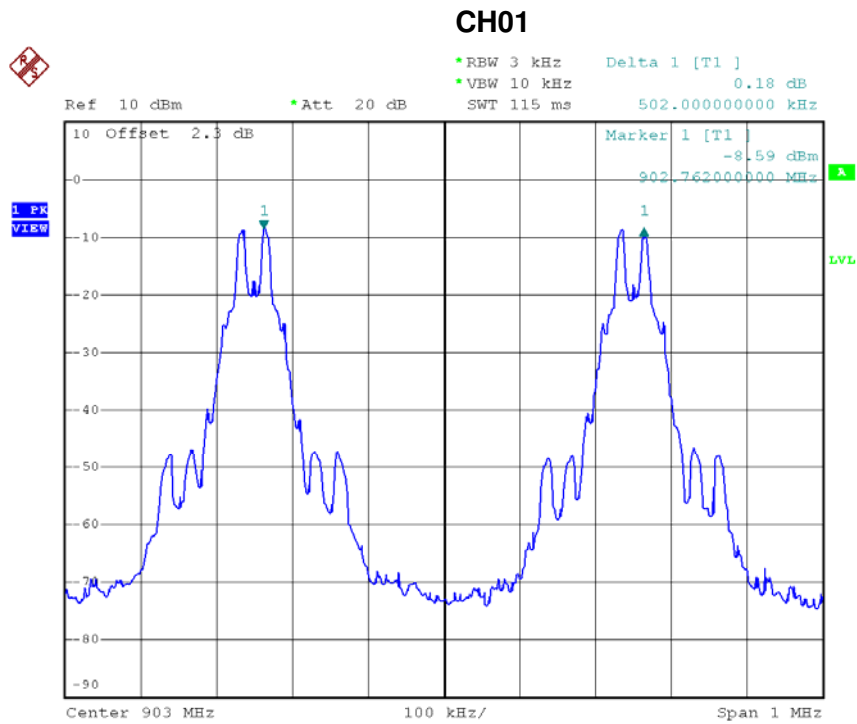

Date: 17.JUL.2016 14:49:37

CH02

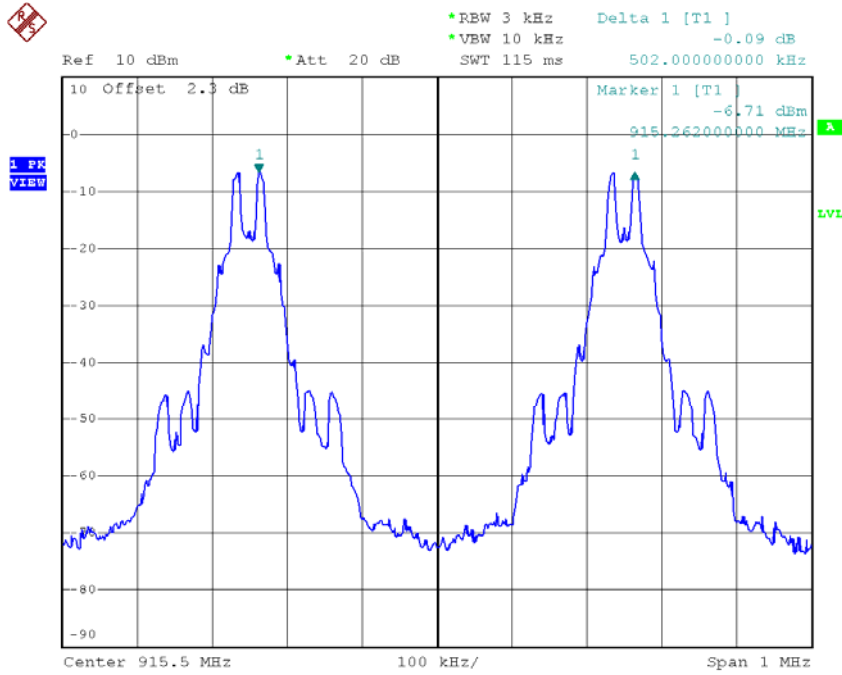

Date: 17.JUL.2016 15:13:01

CH03

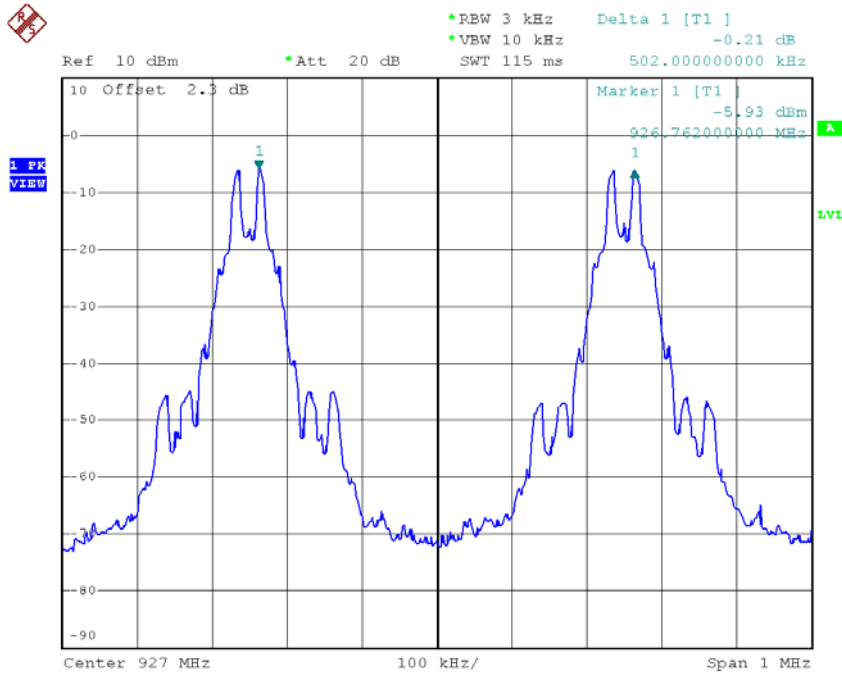

Date: 17.JUL.2016 15:23:36

ATTACHMENT H - BANDWIDTH

Frequency (MHz)	20dB Bandwidth (MHz)	99% Occupied BW (MHz)	Test Result
902.75	0.085	0.079	Complies
915.25	0.085	0.079	Complies
927.25	0.084	0.080	Complies

TX CH01

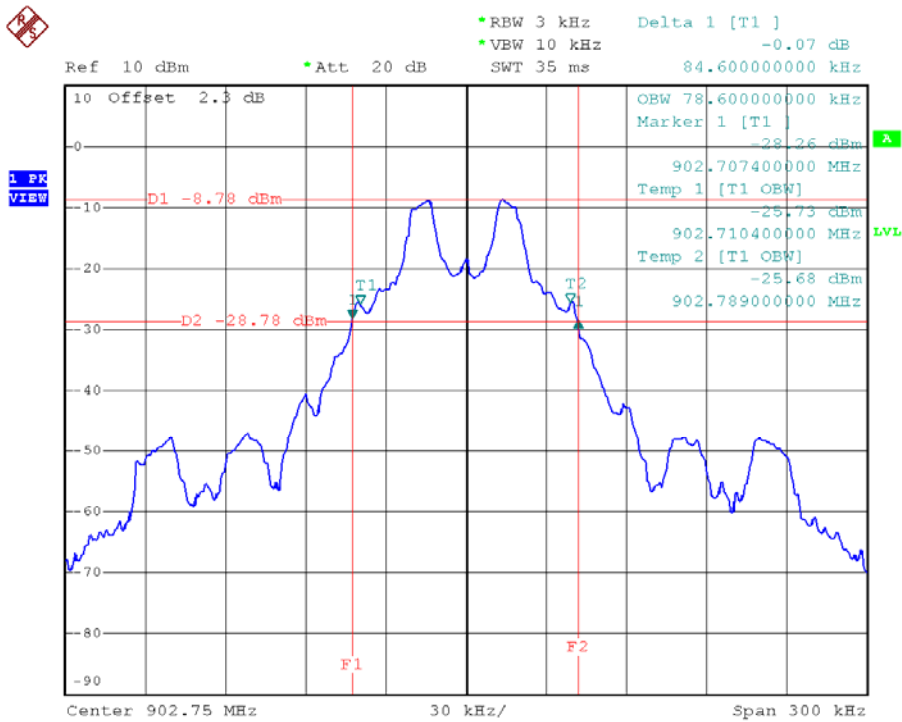

Date: 17.JUL.2016 13:04:14

TX CH02

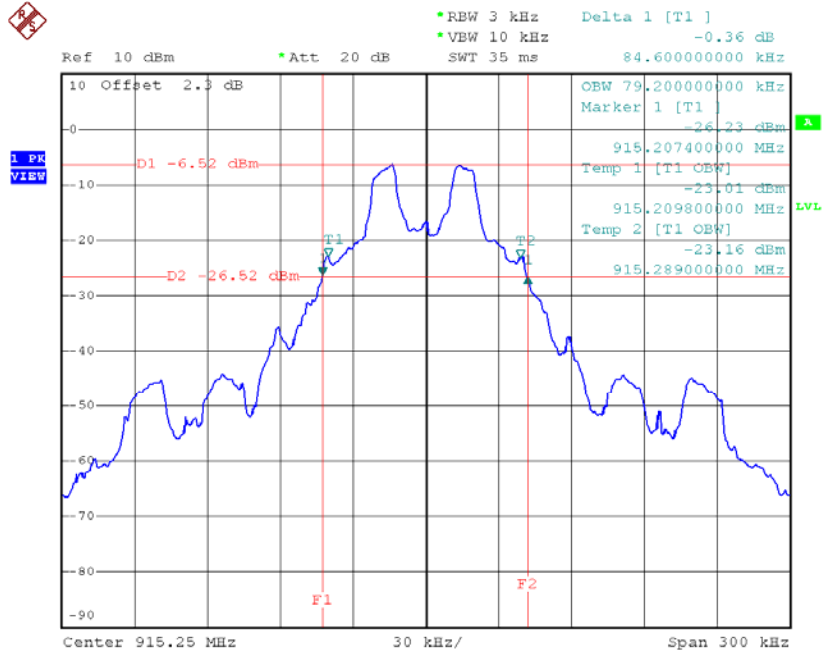

Date: 17.JUL.2016 15:05:30

TX CH03

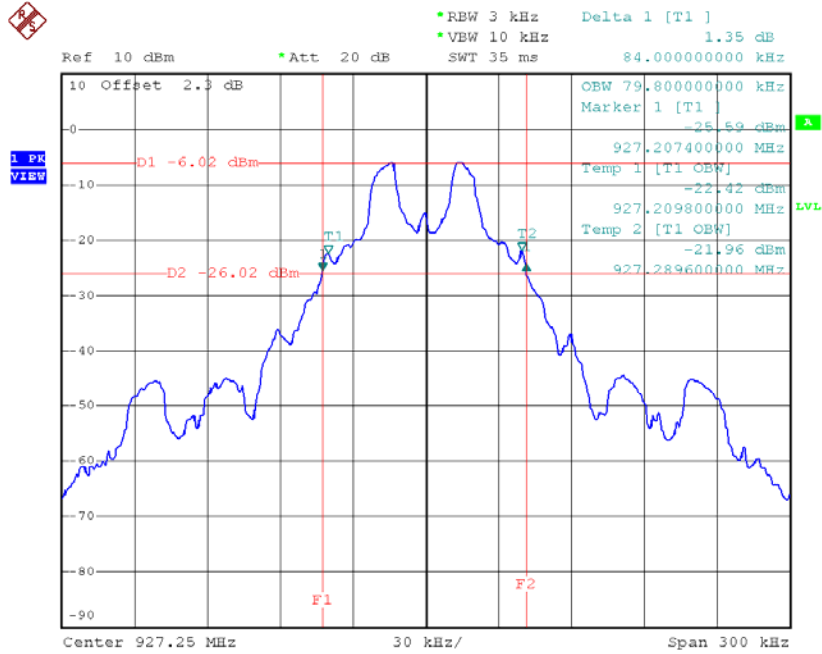

Date: 17.JUL.2016 15:18:41

ATTACHMENT I - PEAK OUTPUT POWER

Test Mode : TX Mode

Frequency (MHz)	Conducted Power (dBm)	Conducted Power (Watt)	Max. Limit (dBm)	Max. Limit (Watt)	Test Result
902.75	6.61	0.0046	30.00	1.0000	Complies
915.25	8.55	0.0072	30.00	1.0000	Complies
927.25	8.98	0.0079	30.00	1.0000	Complies

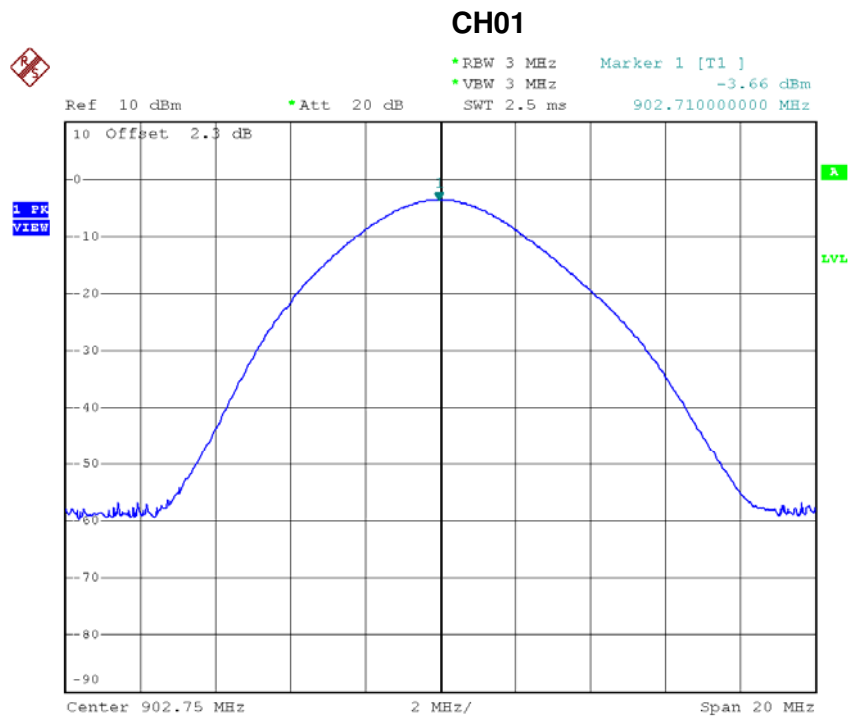

Date: 17.JUL.2016 14:28:28

CH02

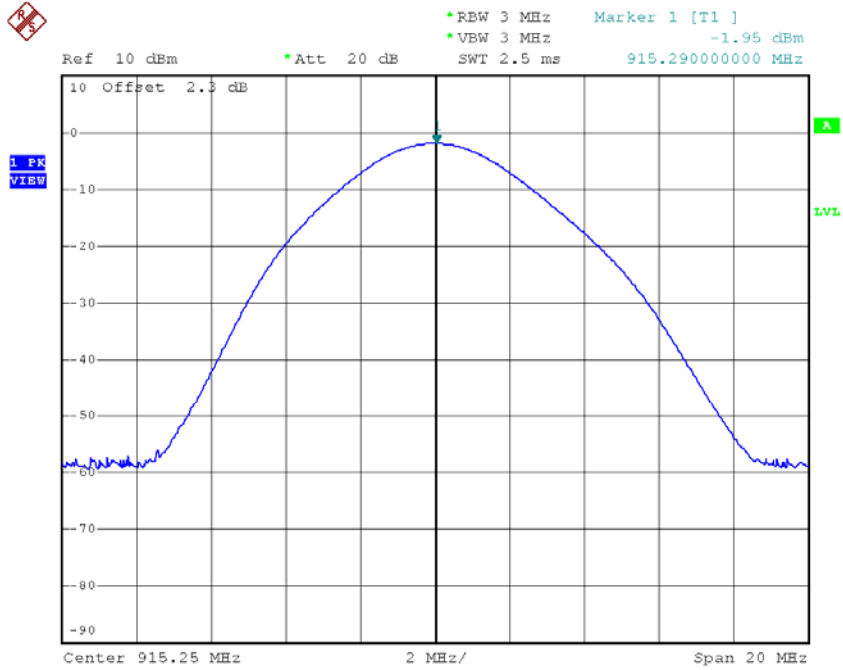

Date: 17.JUL.2016 15:07:53

CH03

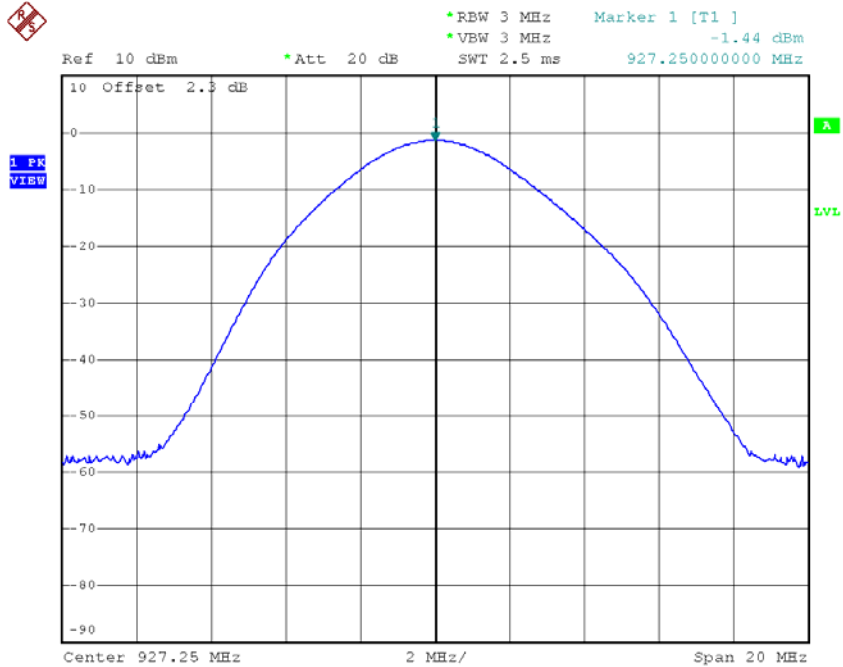

Date: 17.JUL.2016 15:20:21

ATTACHMENT J - ANTENNA CONDUCTED SPURIOUS EMISSION

Test Mode : CH01, CH02 , CH03

CH01 (Lower)

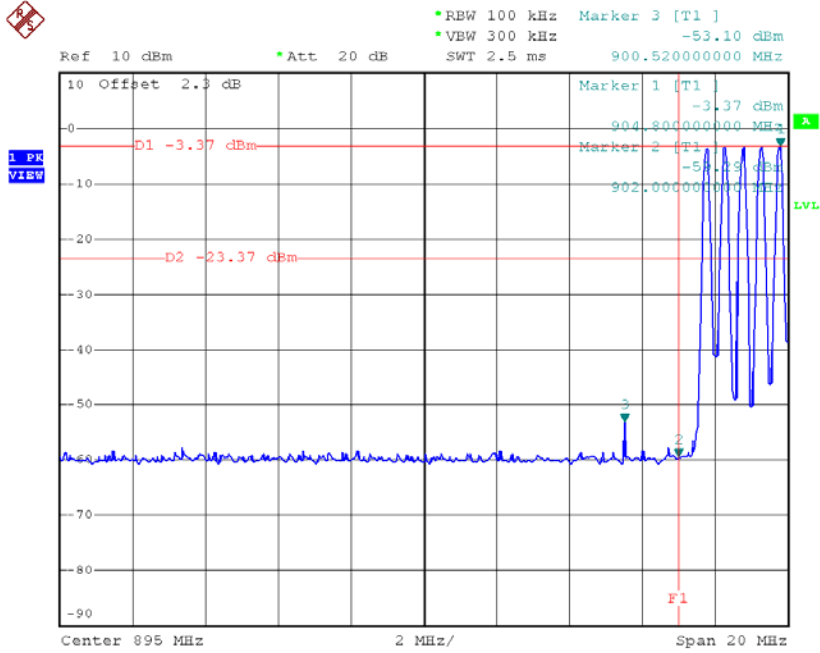

Date: 17.JUL.2016 15:48:42

CH03 (upper)

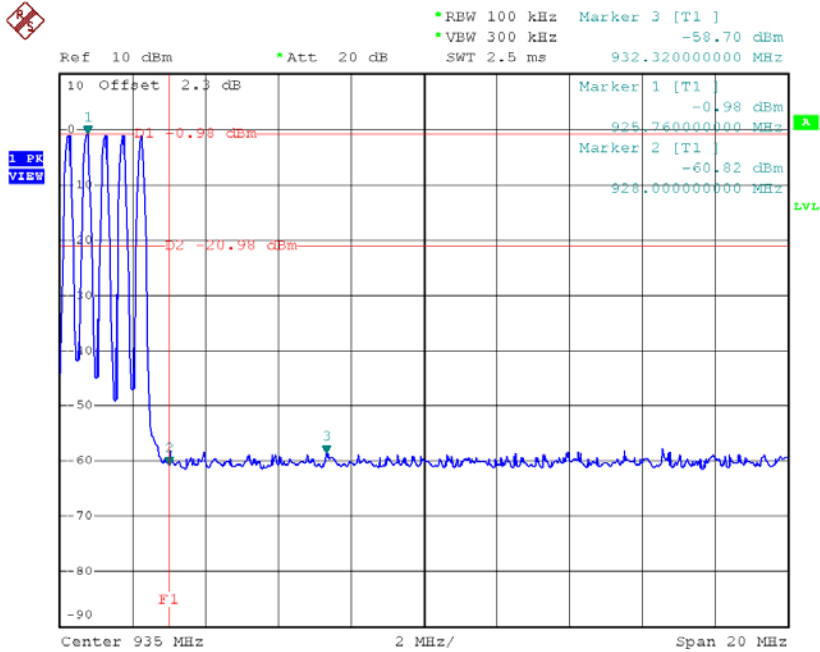

Date: 17.JUL.2016 15:53:50

CH01 (10 Harmonic of the frequency)

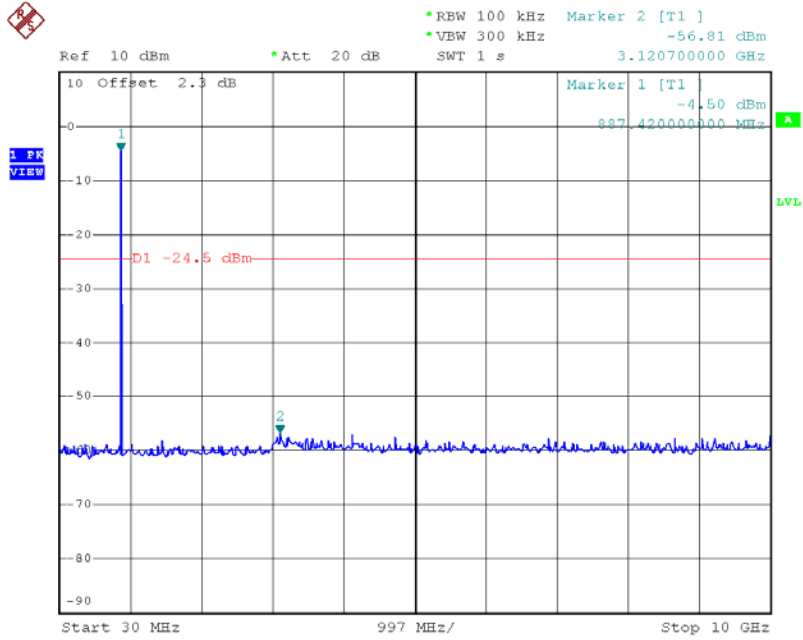

Date: 17.JUL.2016 12:59:12

CH02 (10 Harmonic of the frequency)

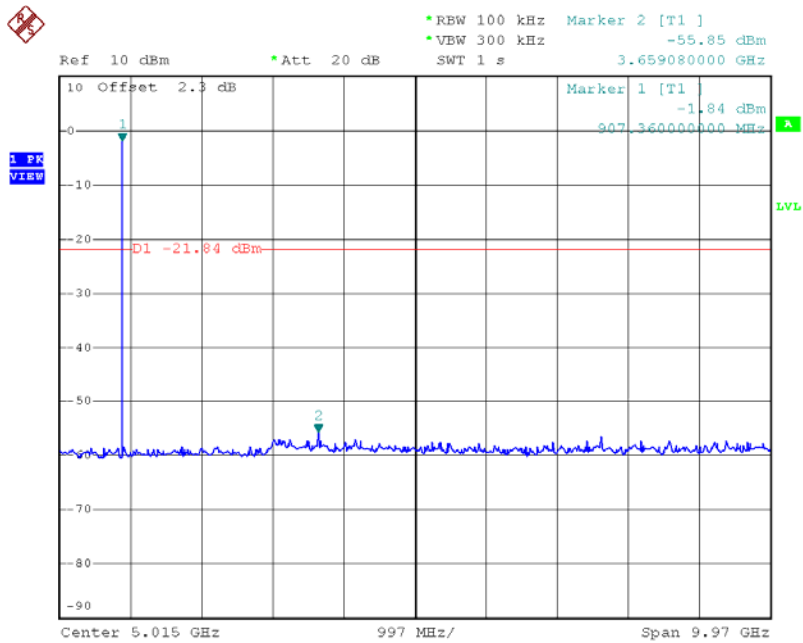

Date: 17.JUL.2016 15:41:30

CH03 (10 Harmonic of the frequency)

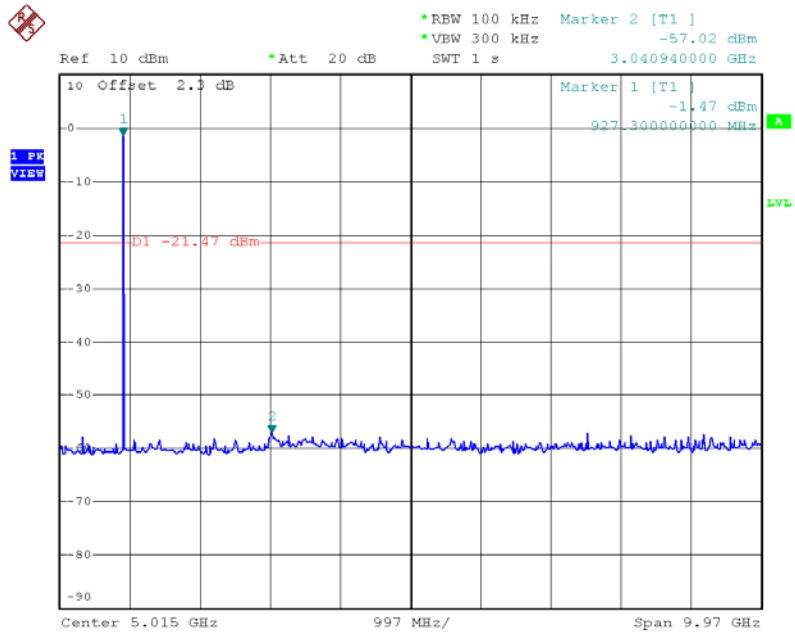

Date: 17.JUL.2016 15:39:07