

**TEC**

TEC Thermal Printer

# **B-480-QP SERIES**

**Owner's Manual**  
**Mode d'emploi**  
**Bedienungsanleitung**  
**Manual de instrucciones**  
**Gebruikershandleiding**

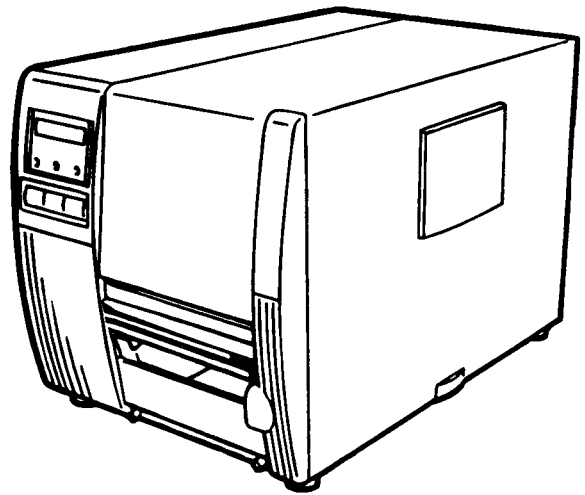

**TOSHIBA TEC CORPORATION**

# DECLARATION OF CONFORMITY

Manufacturer : TOSHIBA TEC Corporation  
Address : 570 Ohito, Ohito-Cho, Tagata-Gun, Shizuoka-Ken, 410-2323 Japan

declares that following product

Product Name : Bar Code Printer  
Model : B-48X-YY  
Options : All

conforms to the following product specifications

Safety : EN 60 950  
EMC : EN 55 022  
EN 61000-4-2  
IEC 1000-4-3  
EN 61000-4-4  
Harmonics : EN 60 555-2, -3

## Supplementary Information

The product herewith complies with the requirements of the Low Voltage Directive 73/23/EEC, and the EMC directive 89/336/EEC.

- 1) The product was tested in a typical set up TOSHIBA TEC personnel advocated.
- 2) The following technical documentation has been filed for review.
  - Factory Inspection Certificate by TÜV Rheinland
  - Owner's Manual
  - Schematic
  - Certificates and Test Reports

**TEC**

TEC Thermal Printer

**B-480 SERIES**

**Owner's Manual**

## TABLE OF CONTENTS

	Page
<b>1. INTRODUCTION</b> .....	<b>E1-1</b>
1.1 Applicable Model .....	E1- 5
1.2 Accessories .....	E1- 5
<b>2. SPECIFICATIONS</b> .....	<b>E2-1</b>
2.1 Printer .....	E2- 1
2.2 Options .....	E2- 2
2.3 Media .....	E2- 3
2.4 Ribbon .....	E2- 3
<b>3. OVERVIEW</b> .....	<b>E3-1</b>
3.1 Front/Rear View .....	E3- 1
3.2 Operation Panel .....	E3- 1
<del><b>4. DIP SWITCH FUNCTIONS</b> .....</del>	<del><b>E4-1</b></del>
<b>5. INSTALLING THE PRINTER</b> .....	<b>E5-1</b>
5.1 Connecting the Power Cord and Cables .....	E5- 1
5.2 Procedure for Fitting Fan Filter .....	E5- 1
<b>6. LOADING THE MEDIA</b> .....	<b>E6-1</b>
<b>7. LOADING THE RIBBON</b> .....	<b>E7-1</b>
<b>8. INSERTING THE OPTIONAL <sup>PCMCIA</sup> FLASH MEMORY CARD</b> .....	<b>E8-1</b>
<b>9. CARE/HANDLING OF THE MEDIA AND RIBBON</b> .....	<b>E9-1</b>
<b>10. GENERAL MAINTENANCE</b> .....	<b>E10-1</b>
10.1 Cleaning .....	E10- 1
10.2 Covers and Paper .....	E10- 1
10.3 Removing Jammed Paper .....	E10- 2
10.4 Threshold Setting .....	E10- 4
<b>11. TROUBLESHOOTING</b> .....	<b>E11-1</b>

**CAUTION:**

1. This manual may not be copied in whole or in part without prior written permission of <sup>TOSHIBA</sup>TEC.
2. The contents of this manual may be changed without notification.
3. Please refer to your local Authorized Service representative with regard to any queries you may have in this manual.

## 1. INTRODUCTION

## 1. INTRODUCTION

## 1. INTRODUCTION

Thank you for choosing the TEC B-<sup>480</sup>~~470~~ series thermal/transfer printer. This high performance printer is equipped with superior hardware including the specially developed (12 dots/mm, <sup>304.8</sup>203.2 dots/inch) near edge print head which will allow very clear print at a maximum speed of 254 mm/sec. (10 inches/sec.). The media supply is internal. ~~Combine this with an optional high speed PC interface board which allows vastly reduced graphic data transfer times and you have a printer to suit a variety of applications and environments.~~ Optional features include an automatic ribbon saver, a built-in rewinder/strip mechanism, external media supply, <sup>and</sup> Centronics I/O interface.

This manual contains general set-up and maintenance information and should be read carefully to help gain maximum performance and life from your printer. For most queries please refer to this manual and keep it safe for future reference.

**WARNING**

*This is a Class A product. In a domestic environment this product may cause radio interference in which case the user may be required to take adequate measures.*

**CAUTION**

*To avoid injury, be careful not to catch or jam your fingers while opening or closing the cover.*

**CAUTION**

*Do not touch moving parts. To reduce the risk that fingers, jewelry, clothing, etc., be drawn into the moving parts, push the switch in the "OFF" position to stop movement.*

**Safety Summary**

Personal safety in handling or maintaining the equipment is extremely important. Warnings and Cautions necessary for safe handling are included in this manual. All warnings and cautions contained in this manual and written inside or outside of the printer should be read and understood before handling or maintaining the equipment.

Do not attempt to effect repairs to this equipment. If a fault occurs that cannot be rectified using the procedures described in this manual, turn off the power, unplug the machine, then contact your authorised TEC representative for assistance.



### Safety Precautions

This Owner's Manual and the products (machines) which you have purchased contain indications which should be observed in order to use the machines safely and prevent harm to yourself and others and damage to property. The meanings of these indications and symbols are given below. Read these indications and become familiar with their contents before reading this Owner's Manual.

The following safety precaution will help to ensure proper use of the printer.

- Unplug the printer whenever you are working inside the printer.
- Keep your work environment static free.

### Meanings of Each Symbol



This symbol indicates warning items (including cautions). Specific warning contents are drawn inside the  $\Delta$  symbol. (The symbol on the left indicates a general caution.)



This symbol indicates prohibited actions (prohibited items). Specific prohibited contents are drawn inside or near the  $\odot$  symbol. (The symbol on the left indicates "no disassembling".)



This symbol indicates actions which must be performed. Specific instructions are drawn inside or near the  $\bullet$  symbol. (The symbol on the left indicates "disconnect the power cord plug from the outlet".)

 **WARNING** This indicates that there is the risk of death or serious injury if the machines are improperly handled contrary to this indication.

 Any other than the specified AC voltage is prohibited.

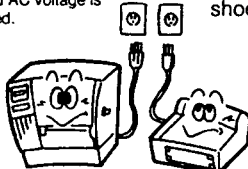

■ Do not use voltages other than the voltage (AC) specified on the rating plate, as this may cause fire or electric shock.

 Prohibited

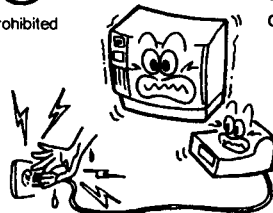

■ Do not plug in or unplug the power cord plug with wet hands as this may cause electric shock.

 Prohibited

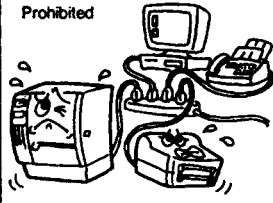

■ If the machines share the same outlet with any other electrical appliances which consume large amounts of power, the voltage will fluctuate widely each time these appliances operate. Be sure to provide an exclusive outlet for the machine as this may cause the machines to malfunction.

 Prohibited

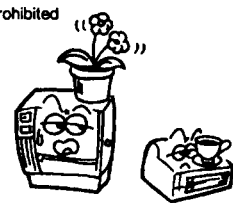

■ Do not place metal objects or water-filled containers such as flower vases, flower pots or mugs, etc. on top of the machines. If metal objects or spilled liquid enter the machines, this may cause fire or electric shock.

 Prohibited

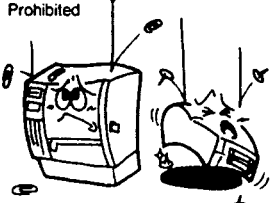





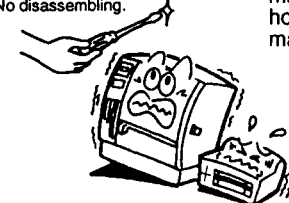





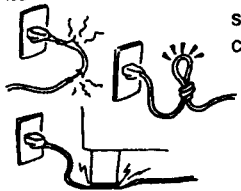

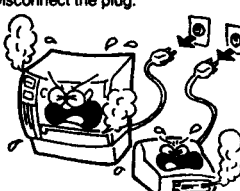

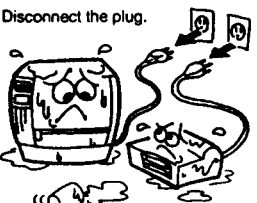

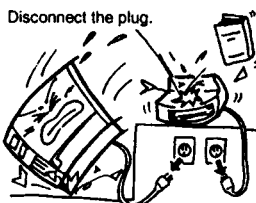
■ Do not insert or drop metal, flammable or other foreign objects into the machines through the ventilation slits, as this may cause fire or electric shock.

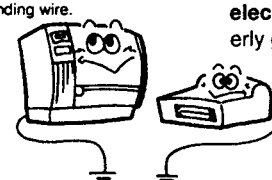
 No disassembling.

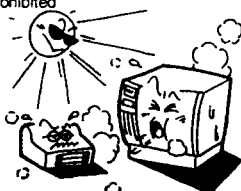

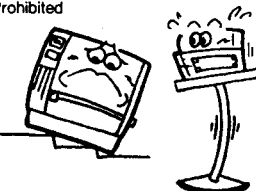

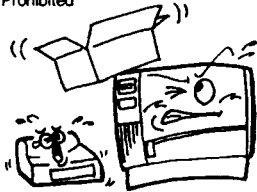

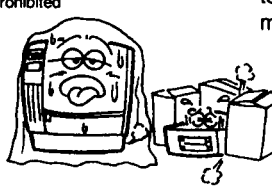

■ Do not remove covers, repair or modify the machine by yourself. You may be injured by high voltage, very hot parts or sharp edges inside the machine.

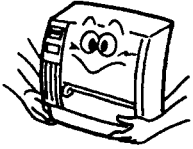

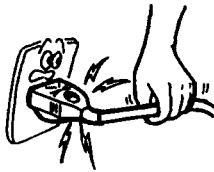
<p> Prohibited</p>  <p>■ Do not scratch, damage or modify the power cords. Also, do not place heavy objects on, pull on, or excessively bend the cords, as this may cause fire or electrical shock.</p>	<p> Disconnect the plug.</p>  <p>■ Continued use of the machines in an abnormal condition such as when the machines are producing smoke or strange smells may cause fire or electric shock. In these cases, immediately turn off the power switches and disconnect the power cord plugs from the outlet. Then, contact your sales agent (or maintenance and service agent).</p>
<p> Disconnect the plug.</p>  <p>■ If foreign objects (metal fragments, water, liquids) enter the machines, first turn off the power switches and disconnect the power cord plugs from the outlet, and then contact your sales agent (or maintenance and service agent). Continued use of the machine in that condition may cause fire or electric shock.</p>	<p> Disconnect the plug.</p>  <p>■ If the machines are dropped or their cabinets damaged, first turn off the power switches and disconnect the power cord plugs from the outlet, and then contact your sales agent (or maintenance and service agent). Continued use of the machine in that condition may cause fire or electric shock.</p>
<p> Connect a grounding wire.</p>  <p>■ Ensure that the equipment is properly grounded. Extension cables should also be grounded. Fire or electric shock can occur on improperly grounded equipment.</p>	
<p> <b>CAUTION</b> This indicates that there is the risk of personal injury or damage to objects if the machines are improperly handled contrary to this indication.</p>	
<p> Prohibited</p>  <p>■ Do not install the machines where they might be exposed to direct sunlight, high humidity, or dust. Otherwise fire or electric shock could occur.</p>	<p> Prohibited</p> <p><b>[Precautions During installation]</b></p>  <p>■ Do not place the machines on unstable or slanted surfaces, as they may drop or fall and cause injury.</p>
<p> Prohibited</p>  <p>■ Do not place heavy objects on top of the machines, as these items may become unbalanced and fall causing injury.</p>	<p> Prohibited</p>  <p>■ Do not block the ventilation slits of the machines, as this will cause heat to build up inside the machines and may cause fire.</p>

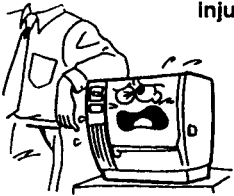

 <p>Caution</p>  <p>■ Be sure to move large scale machines with two or more people. In addition, machines should be moved after first confirming that connecting wires between machines and externally connected wires, etc. have been removed. Failure to observe these precautions may result in <b>injury</b>.</p>	 <p>Disconnect the plug.</p>  <p>■ When unplugging the power cords, be sure to hold and pull on the plug portion. Pulling on the cord portion may cut or expose the internal wires and cause <b>fire or electric shock</b>.</p>
---	--

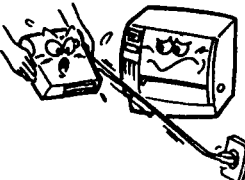
 <p>Caution</p>  <p>■ Do not lean against the machine. It may fall on you and could cause <b>injury</b>.</p>	 <p>Disconnect the plug.</p>  <p><b>[Precautions When Moving the Machines]</b>          ■ When moving the machines, be sure to first unplug the power cords. Moving the machines with the power cords plugged in may damage the cords and cause <b>fire or electric shock</b>.</p>
--	---

**Precaution**

The following precautions will help to ensure that this machine will continue to function correctly.

- ① Try to avoid locations that have the following adverse conditions:
  - \* Temperatures below 5°C and above 40°C
  - \* Direct sunlight
  - \* Shared power socket
  - \* Excessive vibration
- ② The cover should be cleaned by wiping with a dry cloth or a cloth slightly dampened with a mild detergent solution. **NEVER USE THINNER OR ANY OTHER VOLATILE SOLVENT** on the plastic covers.
- ③ **USE ONLY TEC SPECIFIED** labels, tags and ribbons.
- ④ **DO NOT STORE** the labels, tags or ribbons where they might be exposed to direct sunlight, high temperatures, high humidity, dust, or gas.
- ⑤ Ensure the printer is operated on a level surface.
- ⑥ Any data stored in the memory of the printer could be lost during a printer fault.



1. INTRODUCTION

1.1 Applicable Model

1.1 Applicable Model

- B-472QP

Model name description

B-472QP

QP: European version

2: Thermal direct/Thermal transfer

12  
TS#

Issue mode  
S: Batch  
Resolution  
T: 12 dots/mm

1.2 Accessories

Owner's manual  
(EM1-33034)  
E51-33007

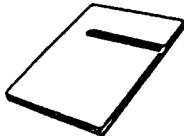

Power cord

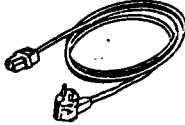

Unpacking procedure

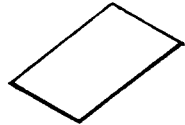

QPのみ  
↓  
Print Head Cleaner  
(24037500013)

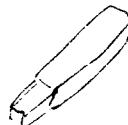

Fan filter  
(FM880036801)

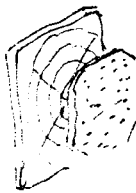

QPのみ →

↑  
1524H.  
B-570-2P O/M #1321E

2. SPECIFICATIONS

2.1 Printer

2. SPECIFICATIONS

2.1 Printer

- TS 12/10 -

Item	Model	B-470-QP
Supply voltage	✓	AC 220V ~ 240V +10%, -15%, 50Hz
Power consumption	✓	1.13 → 1A, 180W maximum (standby: 250mA, 18W) 128 23
Operating temperature range	✓	5°C ~ 40°C (41°F ~ 104°F)
Relative humidity	✓	25% ~ 85%RH (no condensation)
Print head	✓	Thermal print head 12 dots per mm (304.8 dots per inch)
Printing methods	✓	Thermal direct or Thermal transfer
Print speeds	✓	76.2 mm/sec. (3 inch/sec.), 127 152.4 mm/sec. (6 inch/sec.), 5 254 mm/sec. (10 inch/sec.)
Maximum print width	✓	203.2 104.6 mm (4.09 inches) 8 → 101.6 mm/sec. (4 inch/sec.) Thermal direct only.
Dispensing modes		Batch (Continuous), Strip (On-demand) and Cut modes (Both cut and strip modes are available only when their respective modules are fitted.)
Message display	✓	16 characters × 1 line
Dimensions	✓	291 mm (width) × 460 mm (depth) × 308 mm (height)
Weight	✓	17 kg (without media and ribbon)
Available bar code types		UPC-E, UPC-E + 2digits, UPC-E + 5digits UPC-A, UPC-A + 2digits, UPC-A + 5digits JAN8, JAN13, EAN8, EAN8 + 2digits, EAN8 + 5digits 81 82 EAN13, EAN13 + 2digits, EAN13 + 5digits MSI, ITF, NW-7, CODE39, CODE93, CODE128, EAN128 PDF417, DATA MATRIX, Industrial 2 to 5
Fonts		Times Roman (6 sizes), Helvetica (6 sizes), Presentation (1 size), Letter Gothic (1 size), Prestige Elite (2 sizes), Courier (2 sizes), OCR (2 types), Writable characters (40 types), Outline font (1 type), Price font (3 types) 4
Rotations		0°, 90°, 180°, 270°
Standard interface		Serial interface (RS-232C) (20150301 20150301)
Optional interfaces		Parallel interface (Centronics) Expansion I/O interface Flash memory card interface High speed PC interface

PCMCIA

制定： 99年 3月 25日  
 改訂： 年 月 日

NS

NS - F - 32 - 624

(7-2) バーコード種類

項目	A
JAN8,EAN8,JAN13,EAN13,UPC-A,UPC-B	<input checked="" type="checkbox"/>
EAN8,EAN13,UPC-A,UPC-E +2digit	<input checked="" type="checkbox"/>
EAN8,EAN13,UPC-A,UPC-E +5digit	<input checked="" type="checkbox"/>
NW-7	<input checked="" type="checkbox"/>
CODE39(STANDARD)	<input checked="" type="checkbox"/>
CODE39(FULL ASCII)	<input checked="" type="checkbox"/>
ITF	<input checked="" type="checkbox"/>
MSI	<input checked="" type="checkbox"/>
CODE93	<input checked="" type="checkbox"/>
CODE128	<input checked="" type="checkbox"/>
EAN128	<input checked="" type="checkbox"/>
Data Matrix	<input checked="" type="checkbox"/>
PDF417	<input checked="" type="checkbox"/>
QRコード	<input checked="" type="checkbox"/>
industrial 2 of 5	<input checked="" type="checkbox"/>
カスタマーバーコード Customer Bar Code	<input checked="" type="checkbox"/>
POSTNET	<input checked="" type="checkbox"/>
RM4SCC(ROYAL MAIL 4STATE CUSTOMERCONE)	<input checked="" type="checkbox"/>
KIX CODE	<input checked="" type="checkbox"/>
Maxi Code	<input checked="" type="checkbox"/>
μ PDF417	<input checked="" type="checkbox"/>
CPコード CP Code	<input checked="" type="checkbox"/>

(7-3) ライン

(7-3-1) 種類

- (a)横ライン
- (b)縦ライン
- (c)斜線
- (d)四角形
- (e)円, 面取り四角形

(7-3-2) ライン幅

0.1~0.9 mm の範囲で指定可能。(0.1mm 単位)  
 但し、印字品質の保証範囲はサプライ仕様書(TAN-0004)による。

変更	度数	年月日	変更数	変更理由	変更者	承認	流B技 承認	起案	承認	調査	起草
	[1]										
[2]											
[3]								流B技 1	石川	石本	上松
[4]									99-4-10	99-4-2	99-4-2



別紙.

E2-2

№-ジ6-1を参照して下さい。

PCMCIA Interface Board.

このPCMCIA-スロットの取付により以下のPCMCIAカードの使用が可能となります。

- \* LANカード : 3COM EtherLink III (推奨) ~~(必ず参照)~~
- \* ATAカード : PCARD ~~ATA~~ 規格換板
- \* Flashメモカード : 1MB又は4MBのフラッシュカード ~~(必ず参照)~~

注6. フラッシュカードは以下のカードが使用可能です。

別紙 E8-1

Capacity	Maker	Type	Device code	Maker code
1M Byte	Maxell	EF-1M-TB AA	D0H	1CH
	Mitsubishi	MF81M1-GBDAT01		
4M Byte	Maxell	EF-4M-TB CQ	88H	B0H
	Maxell	EF-4M-TB DQ	ADH	04H
	Centennial Technologies INC.	FL04M-15-11119-03		01H
	INTEL	IMC004FLSA	A2H	89H
	Simple TECHNOLOGY	STI-FL/4A		
	Mitsubishi	MF84M1-G7DAT01		
	PC Card KING MAX	FJN-004M6C		
	PC Card	FJP-004M6R	A0H	89H

(1MBカードは1-ドナー, 4MBカード1-ド/3-ドが可能)

~~(注1) LANカードは1側のスロットで動作します。~~ 2-使用して下さい。

注7. LANカードは1側のスロットで動作して下さい。

2. SPECIFICATIONS

2.3 Media

2.3 Media

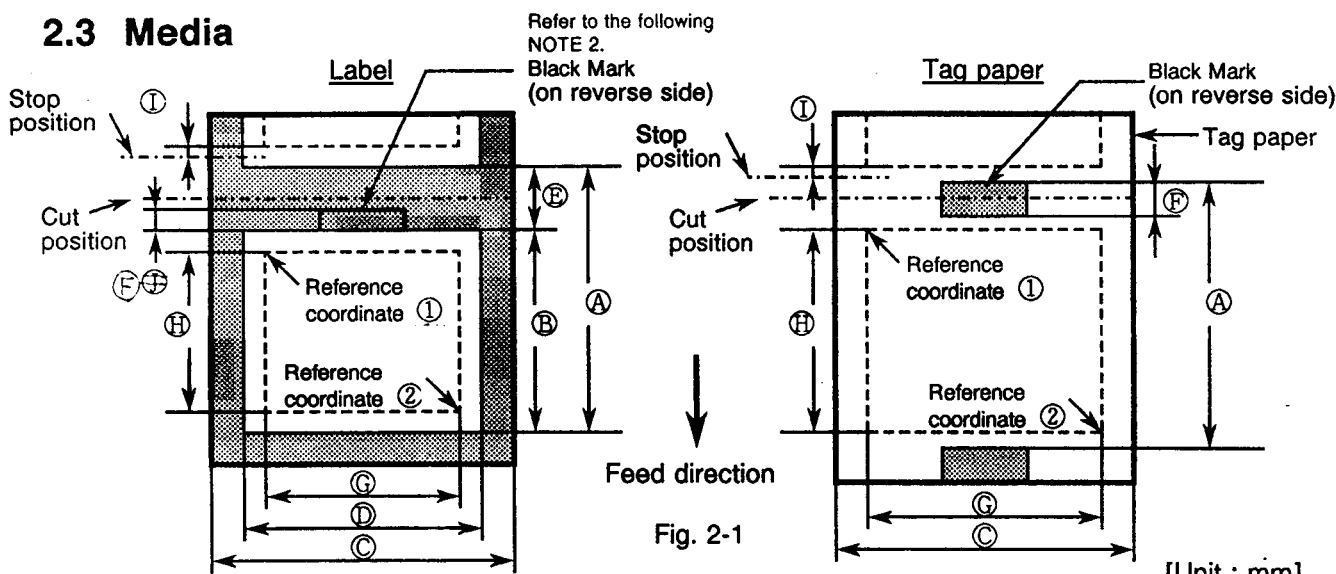

Item		Label dispensing mode	Batch mode	Strip mode	Cut mode
Ⓐ: Span of one label/tag			10.0 ~ 999.0	25.4 ~ 999.0	Label: 38 ~ 999.0 Tag: 25.4 ~ 999.0
Ⓑ: Label/tag length			8.0 ~ 997.0	23.4 ~ 997.0	25.0 ~ 993.0
Ⓒ: Width including backing paper				50.8 ~ 112.0	
Ⓓ: Label width				47.8 ~ 109.0	
Ⓔ: Gap length			2.0 ~ 20.0	2.0 ~ 20.0	6.0 ~ 20.0
Ⓕ: Black mark length (Tag paper)				2.0 ~ 10.0	
Ⓖ: Effective print width				10.0 ~ 104.0	
Ⓖ: Effective print length	Label	Standard	6.0 ~ 384.0	21.4 ~ 384.0	23.0 ~ 384.0
		Max. memory	6.0 ~ 896.0	21.4 ~ 896.0	23.0 ~ 896.0
	Tag	Standard	8.0 ~ 384.0	23.4 ~ 384.0	23.4 ~ 384.0
		Max. memory	8.0 ~ 896.0	23.4 ~ 896.0	23.4 ~ 896.0
Ⓗ: Print speed up/slow down area				1.0	
Ⓙ: Black mark length (Label)			Refer to the following NOTE 2.		
Maximum effective length for on the fly issue	Standard		192.0		
	Max. memory		448.0		
Outer roll diameter			∅200 Max.		
Thickness	Label		0.13 ~ 0.17		
	Tag		0.15 ~ 0.29		

- NOTES: 1. The media specification other than above are unchanged.
2. When marking black marks on label rolls, the following requirements must be satisfied.
- When the gap length is less than 4 mm:  
The black mark length should be longer than the gap length.
- When the gap length is 4 mm or more:  
The black mark should not overlap the gap for more than 4 mm and the following label.

2.4 Ribbon

Type	Spool type
Width	68 mm ~ 112 mm
Length	600 m
Outer diameter	∅90 mm (max.)

- NOTES: 1. "On the fly issue" means that the printer can draw and print without stopping between labels.
2. To ensure print quality and print head life use only TEC specified media and ribbons.
3. When using the cutter ensure that label length Ⓑ plus inter label gap length Ⓔ exceeds 35 mm. (i.e. label pitch should be greater than 35 mm.)
4. When rewinding the media onto the take-up spool in batch mode, the max. outer roll diameter should be 180 mm.
5. Use of rough media for the ribbon saving issue may cause ribbon smudges.

別紙



制定：'99年 3月 25日	<b>NS</b>	NS - F - 32 - 624
改訂： 年 月 日		

4-1-2 印字条件  
(1)印字可能範囲(A)

項目		連続	剥離	カット			
				ロータリーカッター		スینگカッター	
				ヘッドアップなし	ヘッドアップ有り		
Ⓐ ラベルピッチ タグピッチ	ラベル	最小	10.0	25.4	3"/sec:94.0	3"/sec:38.0	38.0
		最大	2730.0				
	タグ	最小	10.0	-	3"/sec:30.0	5"/sec:30.0	
		最大	2730.0	-	8"/sec:38.0	2730.0	
Ⓑ ラベル長	最小	8.0	23.4	3"/sec:81.0 <sup>(*)1</sup>	3"/sec:25.0	25.0 <sup>(*)4</sup>	
				5"/sec:89.0 <sup>(*)2</sup>	5"/sec:25.0		
				8"/sec:100.0 <sup>(*)3</sup>	8"/sec:25.0		
		最大	2728.0	2724.0			
Ⓒ 台紙幅 タグ幅	最小	50.8					
	最大	112.0					
Ⓓ ラベル幅	最小	47.8					
	最大	109.0					
Ⓔ キャップ長	最小	2.0	6.0				
	最大	20.0					
Ⓕ 黒マーク長	最小	2.0					
	最大	10.0					
Ⓖ 有効印字幅	最小	10.0					
	最大	106.7±0.2					
Ⓖ 有効印字長	ラベル	最小	6.0	21.4	3"/sec:79.0	3"/sec:23.0	23.0
					5"/sec:87.0	5"/sec:23.0	
					8"/sec:98.0	8"/sec:23.0	
	最大	2726.0					
タグ	最小	8.0	-	3"/sec:28.0	23.0		
				5"/sec:28.0			
				8"/sec:36.0			
最大	2726.0	-	2726.0				
Ⓖ スローアップ区間		1.0					
用紙厚さ	最小	130 μm	150 μm				
	最大	170 μm	290 μm				
オンザフライ発行可能な 最大有効印字長		1361.0					
Super roll direct		φ200 Max.					

変更	度数	年月日	変更数	変更理由	変更者	承認	流B技 承認	起案	承認	調査	起草
	[1]										
	[2]										
	[3]										
	[4]							流B技 1	石川	杉本	上松
									99-4-10	99-4-2	99-4-2

別紙



TECS-13

制定：'99年 3月 25日

NS

NS - F - 32 - 624

改訂： 年 月 日

NOTES:

2.

- (\*1)ロータリーカッターでのカット発行時、3"/secでのラベル長は、  
ラベル長  $\geq$  91.0mm - (ギャップ長/2)でなければならない。
- (\*2)ロータリーカッターでのカット発行時、5"/secでのラベル長は、  
ラベル長  $\geq$  99.0mm - (ギャップ長/2)でなければならない。
- (\*3)ロータリーカッターでのカット発行時、8"/secでのラベル長は、  
ラベル長  $\geq$  110.0mm - (ギャップ長/2)でなければならない。
- (\*4)スイングカッターでのカット発行時、ラベル長は、  
ラベル長  $\geq$  35.0mm - (ギャップ長/2)でなければならない。

(2)印字位置設定基準

- ・戻だしの文字の印字位置の基準は文字のベースライン左端とし、(1)で示す有効印字エリア原点①からの位置(X, Y)とする。
  - ・戻だしのバーコードの印字位置の基準は左端バーの上とし、(1)で示す有効印字エリア原点①からの位置(X, Y)とする。
- 詳細は TAA-0965 ソフトウェア仕様書による。

4-1-3 用紙

サプライ仕様書(TAN-0004)を参照のこと。

変	度数	年月日	変更数	変更理由	変更者	承認	流B技 承認	起案	承認	調査	起草
更	[1]						流B技 承認				
	[2]							流B技 1	乙	抄本	上松
	[3]								99-4-0	99-4-2	99-4-2
	[4]										



3. OVERVIEW

3.1 Front/Rear View

3. OVERVIEW

3.1 Front/Rear View

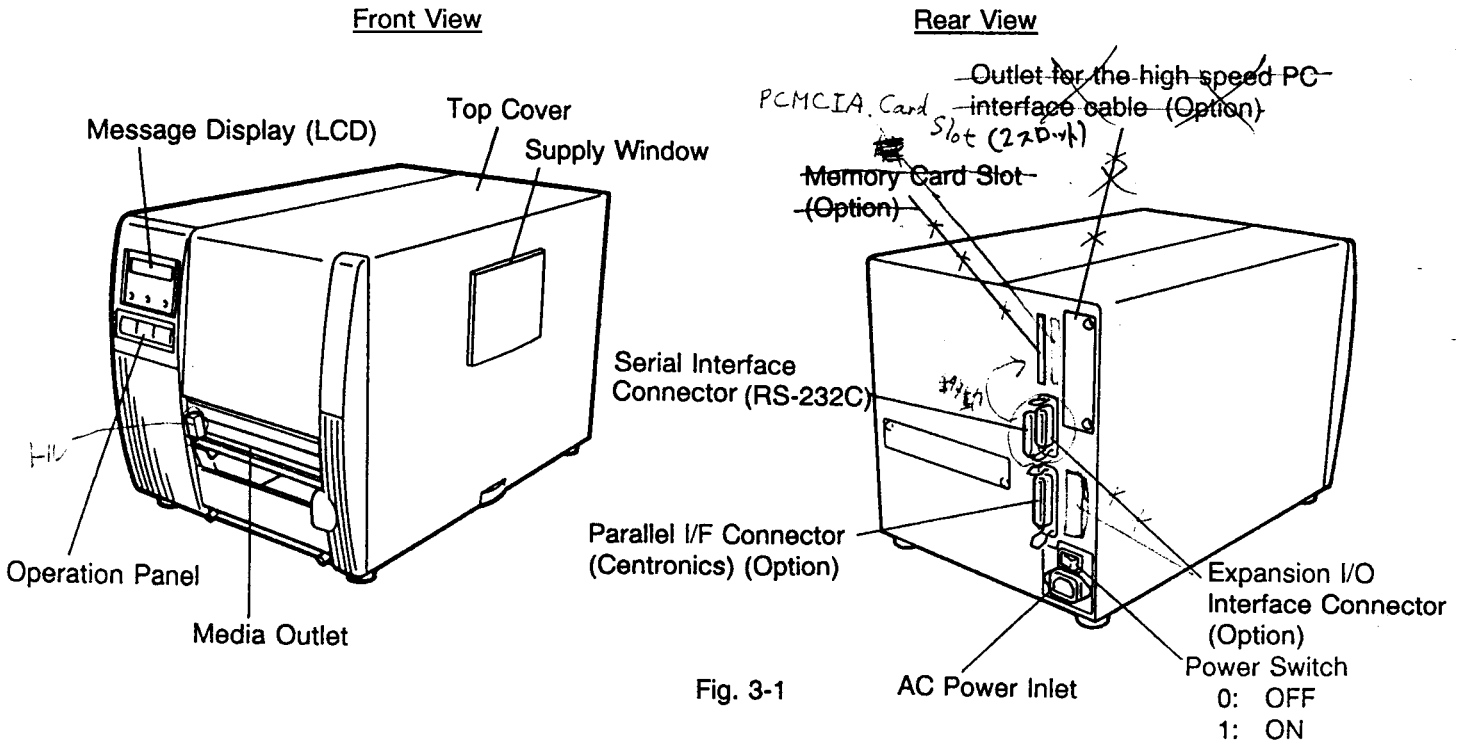

Fig. 3-1

3.2 Operation Panel

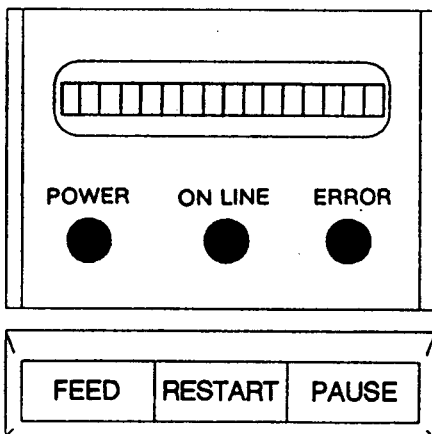

Fig. 3-2

**MESSAGE DISPLAY (LCD)**

Displays messages in the language selected by DIP switch. When power is turned on and it is ready to print, "ON LINE" is displayed.

**POWER LED (Green)**

Lights when the power is turned on.

**ON-LINE LED (Green)**

- 1) Flashes when communicating with a host computer.
- 2) On while printing.

**ERROR LED (Red)**

Lights when a communication error occurs, when the media/ribbon ends or the printer does not operate correctly.

**FEED key**

Feeds paper.

**RESTART key**

Resets the printer when paused or when an error occurs. Used to set the threshold. (Refer to page 10-3)

**PAUSE key**

Pauses printing. Message display shows "PAUSE" and an unprinted count. Used to set the threshold. (Refer to page 10-3)

FW

4. DIP SWITCH FUNCTIONS

4. DIP SWITCH FUNCTIONS

4. DIP SWITCH FUNCTIONS

The DIP switches are located to the right of the supply shaft.

**WARNING:**

Turn the **POWER OFF** before switching the functions.

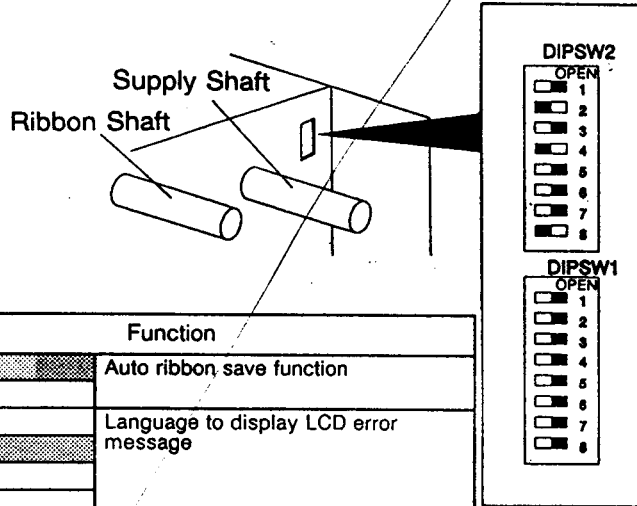

Fig. 4-1

(1) DIP SW 1

No.	ON/OFF		Function	
1	OFF		Without	
	ON		With	
2	2	3	4	
	OFF	OFF	OFF	English
	ON	OFF	OFF	German
	OFF	ON	OFF	French
3	ON	ON	OFF	Dutch
	OFF	OFF	ON	Spanish
	ON	OFF	ON	Japanese
4	OFF	ON	ON	Italian
	ON	ON	ON	Not used
5	OFF		Without	
	ON		With	
6	OFF		Without	
	ON		With	
7	OFF		Must be set to OFF.	
	ON			
8	OFF		Must be set to OFF.	
	ON			

(2) DIP SW 2

No.	ON/OFF		Function
1	1	2	Transmission speed
	OFF	OFF	
2	ON	OFF	4800BPS
	OFF	ON	9600BPS
3	ON	ON	19200BPS
	OFF	OFF	1 bit
4	ON	ON	2 bits
	OFF	OFF	7 bits
5	ON	ON	8 bits
	OFF	OFF	without
6	ON	ON	with
	OFF	OFF	EVEN
7	ON	ON	ODD
	OFF	OFF	Parity check (effective when DIP SW #5 is set to ON.)
8	7	8	Data protocol
	OFF	OFF	
9	ON	OFF	READY/BUSY (DTR) (No XON is output at the power on time.) (No XOFF is output at the power off time.)
	OFF	ON	XON/XOFF + READY/BUSY (XON is output at the power on time.) (XOFF is output at the power off time.)
10	ON	ON	XON/XOFF (XON is output at the power on time.) (XOFF is output at the power off time.)
	ON	ON	

NOTES: 1. The shaded settings are the factory default settings. "OFF" means "OPEN".  
2. The Dip switch #1-6 functions in accordance with equipment to be used.

## 5. INSTALLING THE PRINTER

### 5.1 Connecting the Power Cord and Cables

## 5. INSTALLING THE PRINTER

### 5.1 Connecting the Power Cord and Cables

**WARNING:**

Turn the **POWER SWITCH** to **OFF** before connecting the power cord or cables.

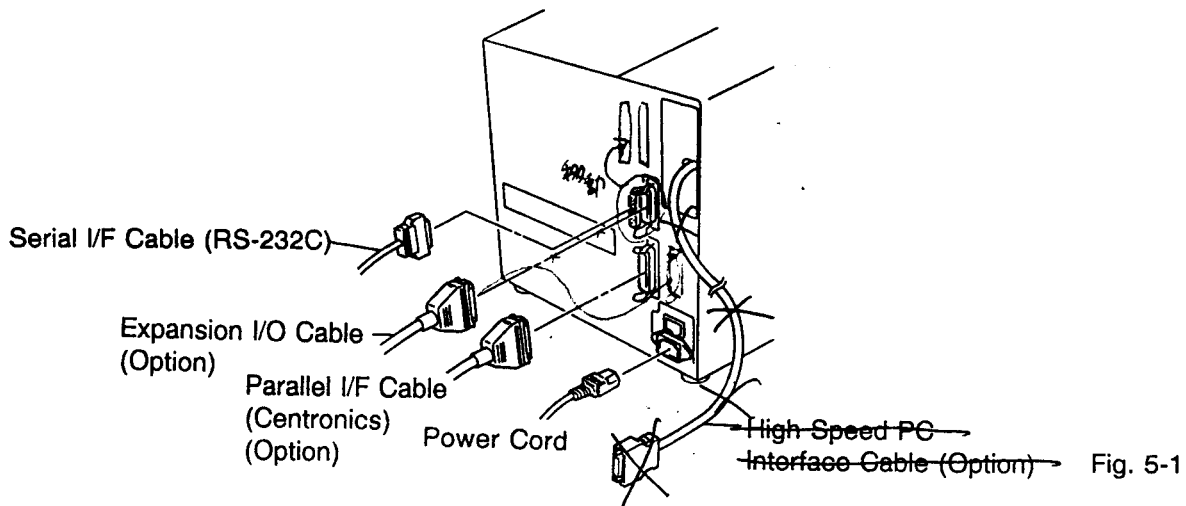

### 5.2 Procedure for Fitting Fan Filter

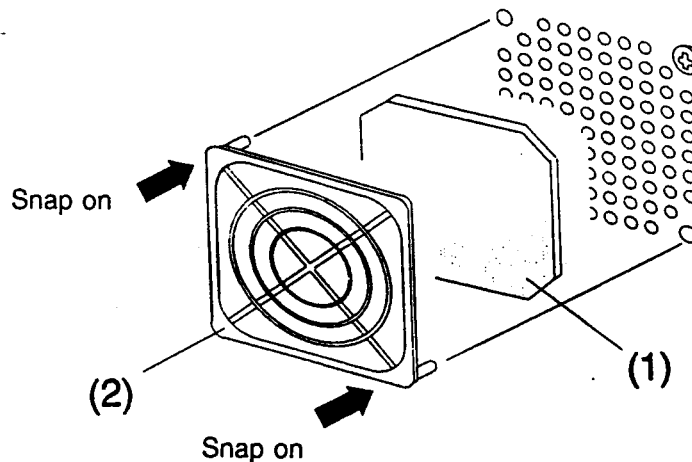

Fig. 5-2

When installing the printer, it is important to ensure that the fan filter is attached before using the printer.

The filter comes in 2 parts:

- (1) FILTER PAD
- (2) FILTER RETAINER

To fit put the filter pad inside the filter retainer and simply press into place according to the diagram above, ensuring connecting pins are aligned with connecting holes.

6. LOADING THE MEDIA

## 6. LOADING THE MEDIA

The printer prints both labels and tags.

1. Turn off the power and open the top cover.
2. Turn the head lever to position ③, then release the ribbon shaft holder plate.

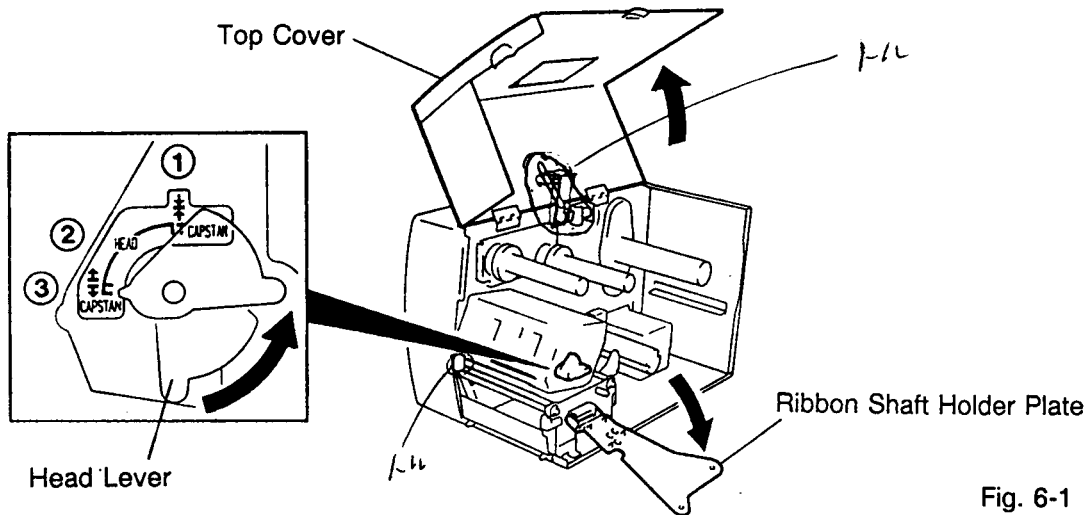

Fig. 6-1

- NOTES:**
1. When the head lever is turned to position ②, the print head is raised.
  2. When the head lever is turned to position ③, the print head and the pinch roller are raised.
  3. To allow printing the head lever must be set to position ①. (This ensures that the print head and the pinch roller are closed.)

3. Untape the supply holder.
4. Turn the outside supply holder 30 degrees and remove from the supply shaft.

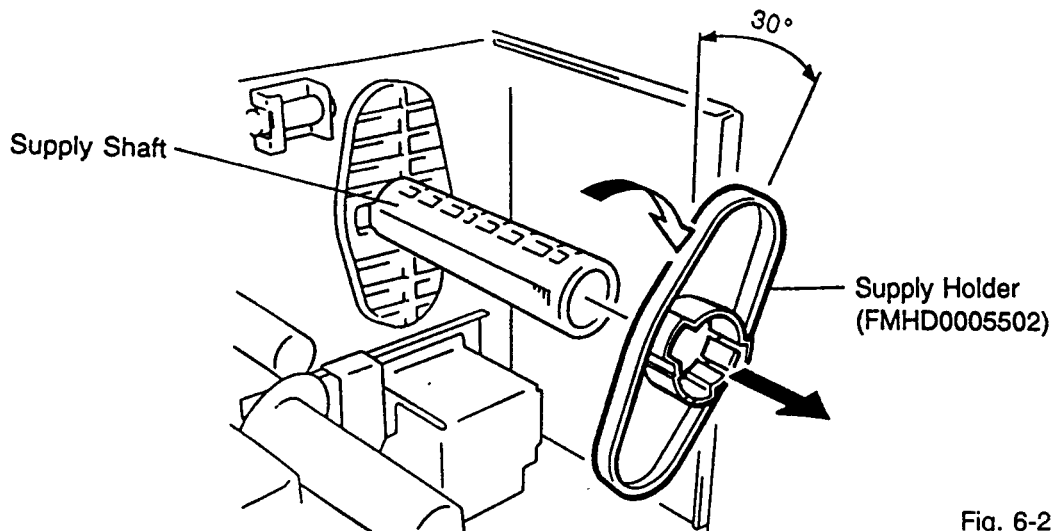

Fig. 6-2

**NOTE:** Set the inside supply holder to the scale on the shaft according to media to be used.

6. LOADING THE MEDIA

6. LOADING THE MEDIA

5. Put the media on the supply shaft.
6. Pass the media around the damper, then pull the media towards the front of the printer. Fix the remaining supply holder to the supply shaft with the pinchers facing away from the printer.

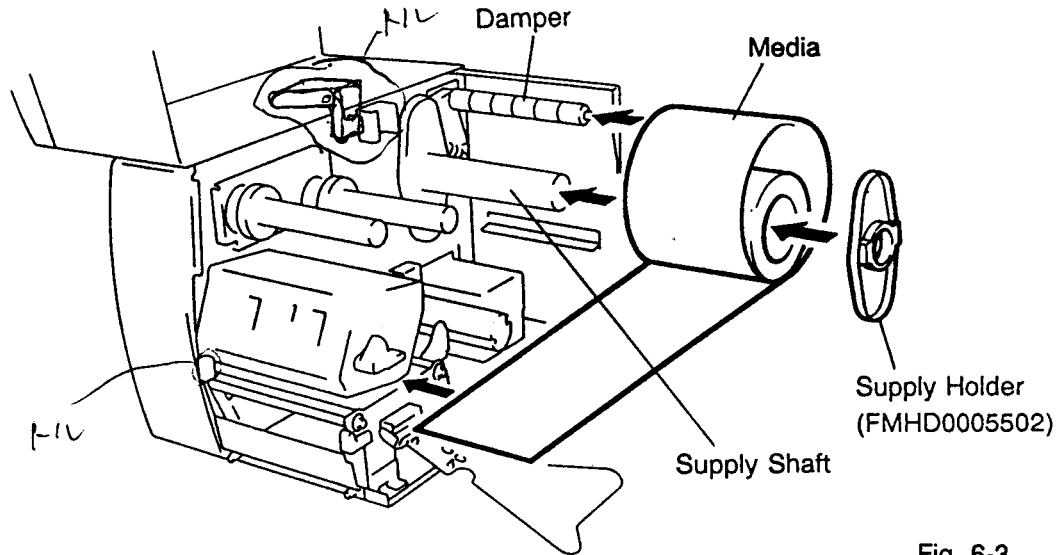

Fig. 6-3

7. Insert the media into the paper holders of the media guide, adjust the media guides to the media width, and tighten the locking screw.
8. Check that the media path through the printer is straight. The media should be centered under the print head.

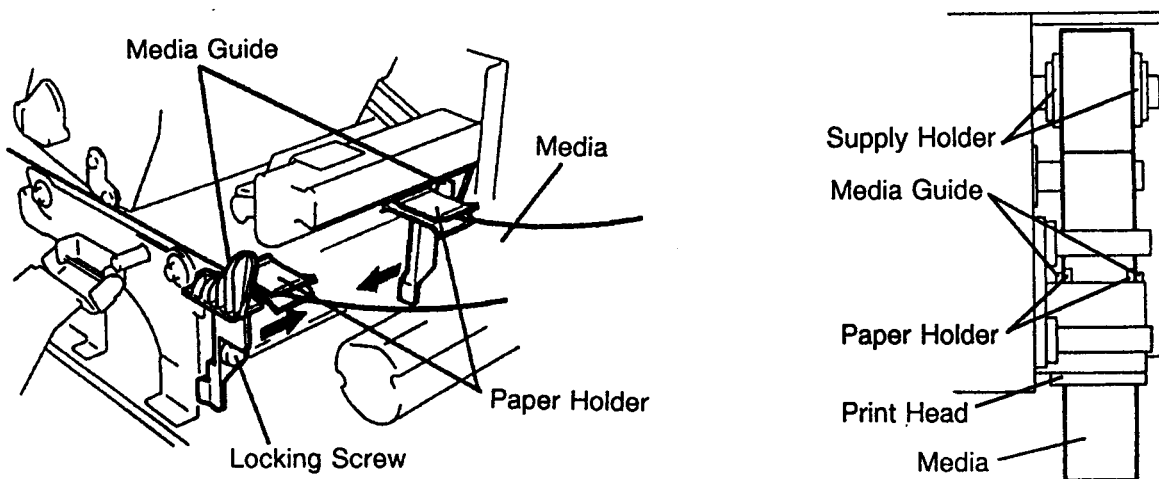

Fig. 6-4

**NOTE:** When using the label rolled with labels facing outside, please remove the upper plates of both paper holders using the following procedure. Failure to do this may cause a paper jam error.  
If you have any questions, please contact your nearest TEC service representative.

TOSHIBA

### ■ Removing the paper holders' upper plates from the media guide

- ① Remove the two T-4×8 screws to detach the media guide from the printer.

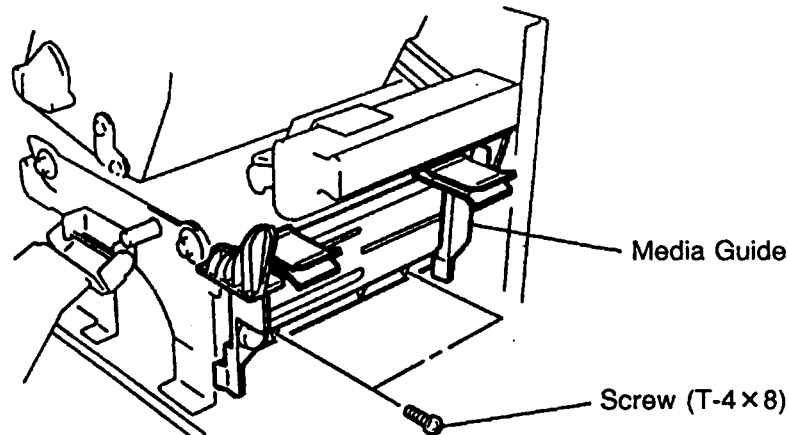

Fig. 6-5

- ② Remove the SM-3×6 screw or the SM-3×8 screw to detach the paper holders' upper plates from the media guide.

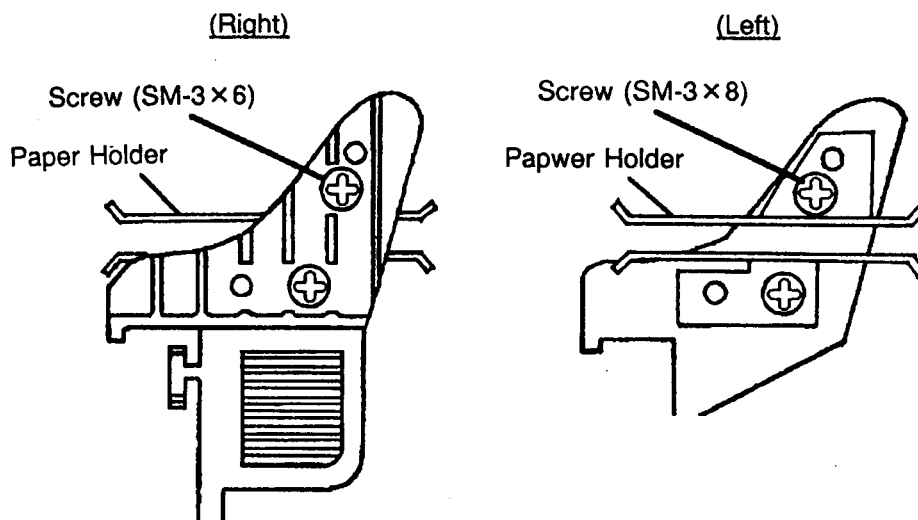

Fig. 6-6

- ③ Attach the media guide back in position.

**NOTE:** Do not lose the removed upper plates because they are required when using the label rolled with labels facing inside.

9. Set the black mark/feed gap sensor to the correct position by turning the adjusting knob. Turning the knob right will move the sensor towards the center of the media while turning left will move it away from the center of the media.

6. LOADING THE MEDIA

6. LOADING THE MEDIA

■ An easy way to set the black mark sensor position

- ① Pull the media about 500 mm out of the front of the printer, turn the media back on it's self and feed it under the print head past the sensor so that the black mark can be seen from above.
- ② Adjust the sensor position to that of the black mark (the upper hole indicates the position of the black mark sensor).

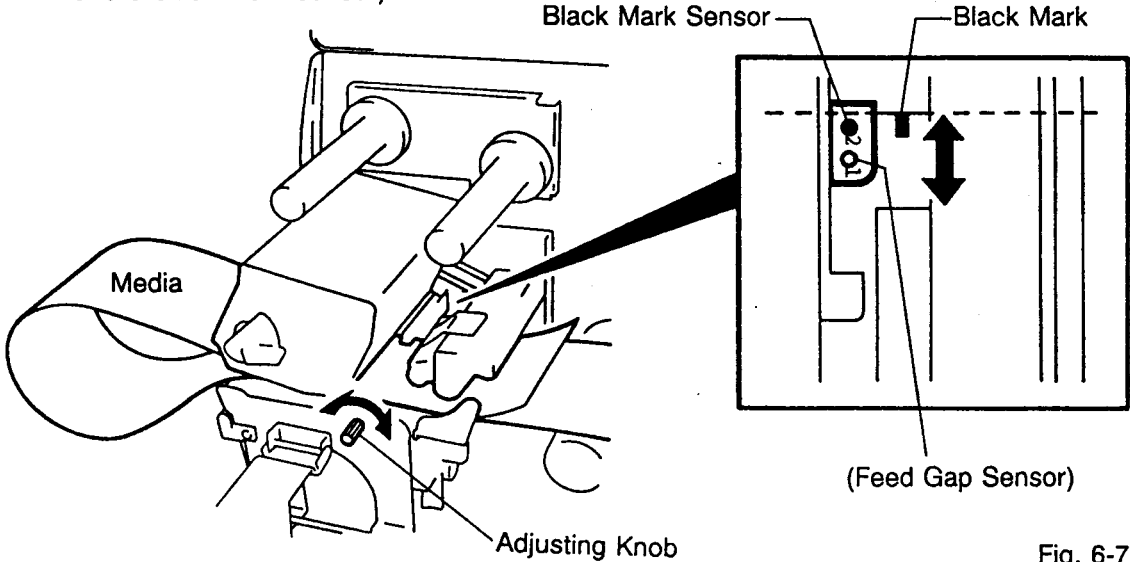

Fig. 6-7

**NOTE:** Make sure to set the sensor to detect the center of the black mark, otherwise a paper jam error could occur.

■ Setting the feed gap sensor position

- ① Adjust the sensor to detect on the gap (the lower hole indicates the position of the feed gap sensor.)

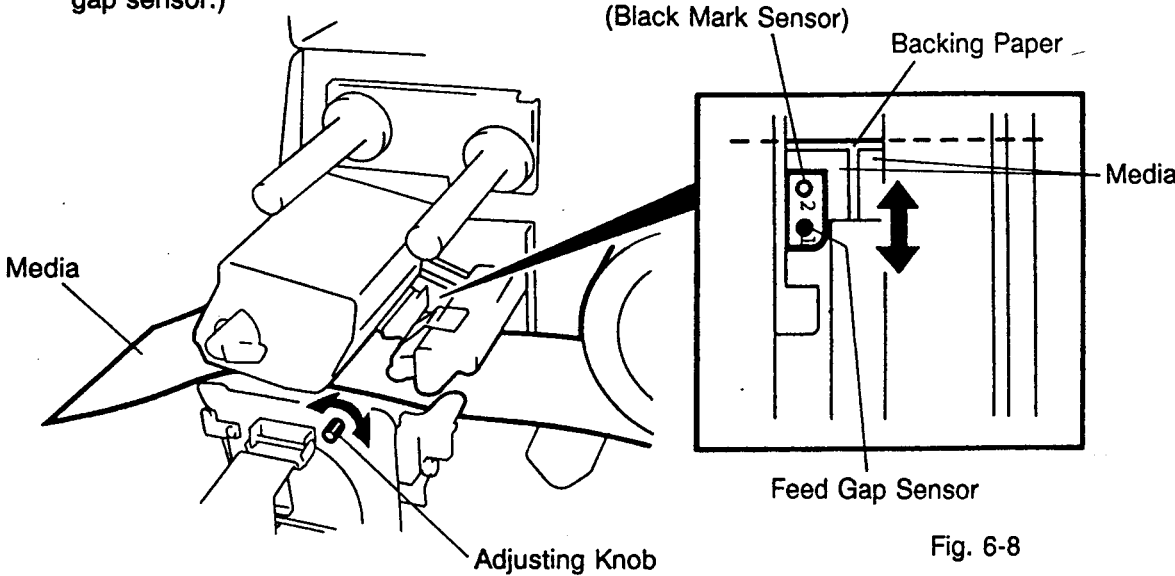

Fig. 6-8

10. The media is now loaded and the sensor position is set.

Batch type:

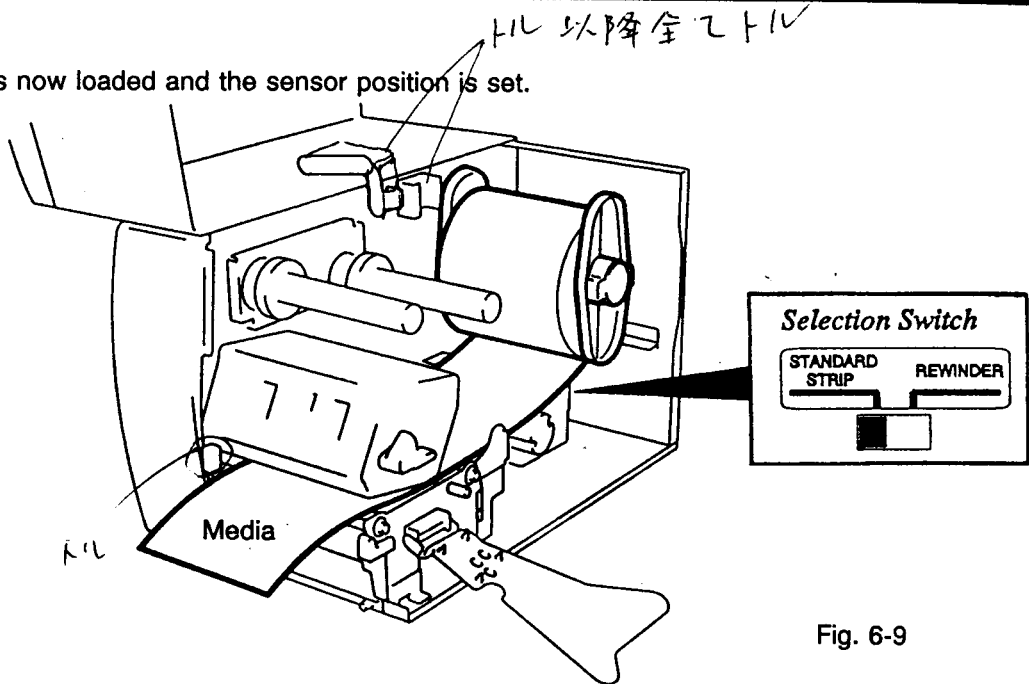

Fig. 6-9

**NOTE:** Set the selection switch to the STANDARD/STRIP position. Improper setting can affect the print quality.

Strip type:

- ① Remove enough labels from the leading edge media to leave 500 mm of backing paper exposed.
- ② Wind the backing paper onto the take-up spool and fix in position with the take-up clip. (Wind the paper counter clockwise around the spool as this is the direction it rotates.)
- ③ Rotate the take-up spool anti-clockwise a few times to take up any slack in the backing paper.

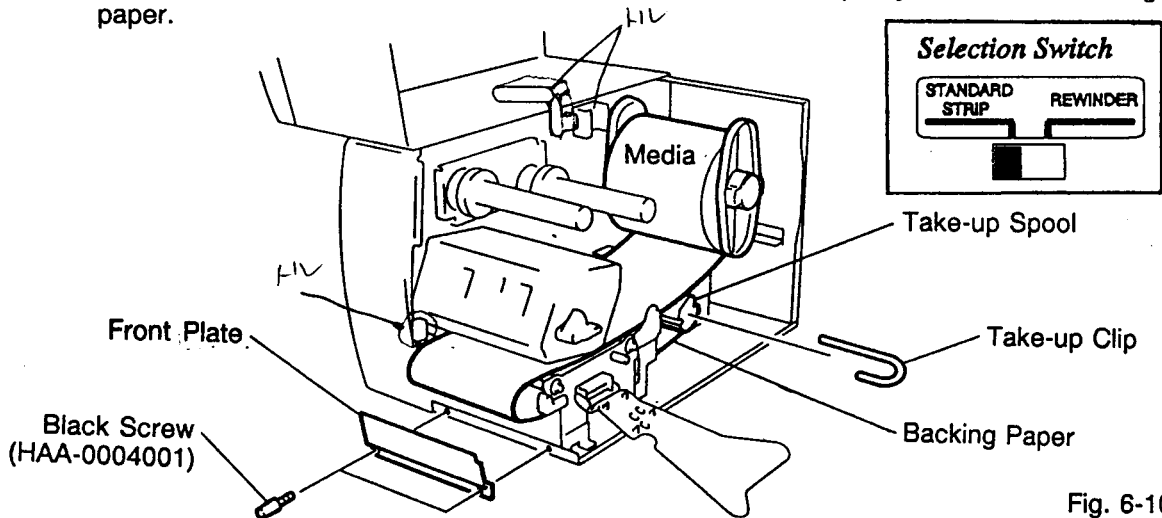

Fig. 6-10

- NOTES:**
1. The backing paper is easier to feed back to the take-up spool if the front plate is removed.
  2. When fitting the take-up clip the longer side of the clip should be fitted into the shallow groove on the take-up spool.
  3. When printer at a speed of 10"/sec., strip function is unavailable.
  4. Set the selection switch to the STANDARD/STRIP position.



～を行なう場合は 最寄りの TOSHIBA TEC 販売代理店に相談して下さい。

ENGLISH VERSION EM1-33034I

## 6. LOADING THE MEDIA

## 6. LOADING THE MEDIA

Cutter type: Where a cutter is fitted load the media as standard and feed it through the cutter module.

- NOTES:**
1. Be sure to cut the backing paper of label. Cutting labels will cause the glue to stick to the cutter, which may affect the cutter quality and shorten the life.
  2. If the top edge of label winds onto the platen in cut issue, ~~set the DIP SW 1-5 to ON.~~
  3. For the cutter type, the selection switch can be set to either position.

このカッターには スイックカッターとロータリーカッターの  
種類があります。ここでは スイックカッターでの  
用例を紹介します。

形状は異なりますが 使用法 Media Outlet  
は同様に行ないます。

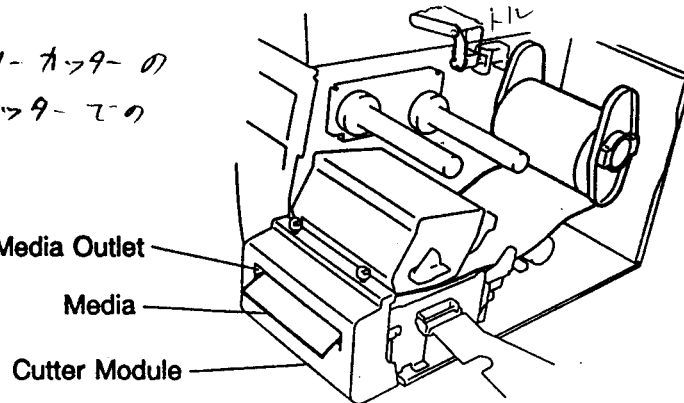

Fig. 6-11

Built-in rewinder type:

- ① Remove two black screws and front plate.
- ② Fit the rewinder guide plate to the strip shaft, then attach it with the sems screws.

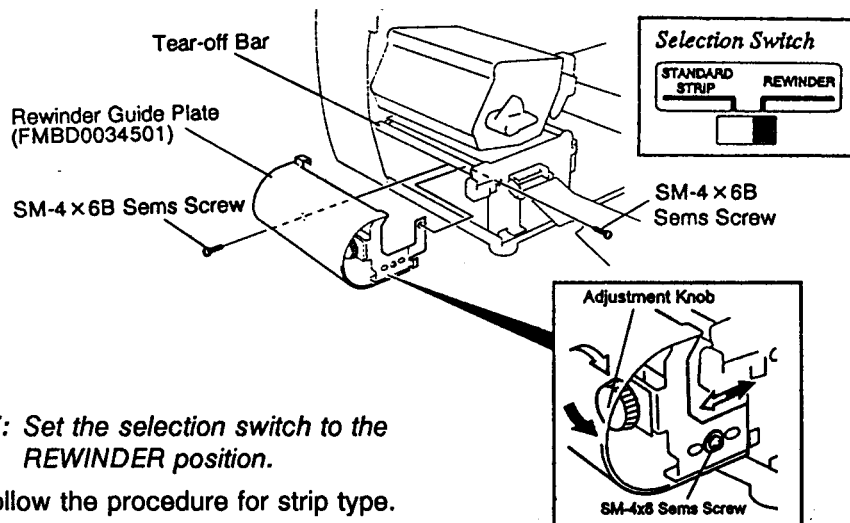

Fig. 6-12

**NOTE:** Set the selection switch to the REWINDER position.

- ③ Follow the procedure for strip type.
- ④ Adjustment

If the label skews when using built-in rewinder unit, turn the adjustment knob of the rewinder guide plate to correct the label feed. Clockwise turn moves the rewinder guide plate forward and counterclockwise moves it backward.

\* When labels skew to the right:

Loosen the SM-4x8 sems screw with a phillips-head screw driver. Turn the adjustment knob clockwise, and tighten the SM-4x8 screw when the rewinder guide plate is positioned correctly.

\* When labels skew to the left:

Loosen the SM-4x8 screw with a phillips-head screw driver. Turn the adjustment knob counterclockwise, and tighten the SM-4x8 screw when the rewinder guide plate is positioned correctly.

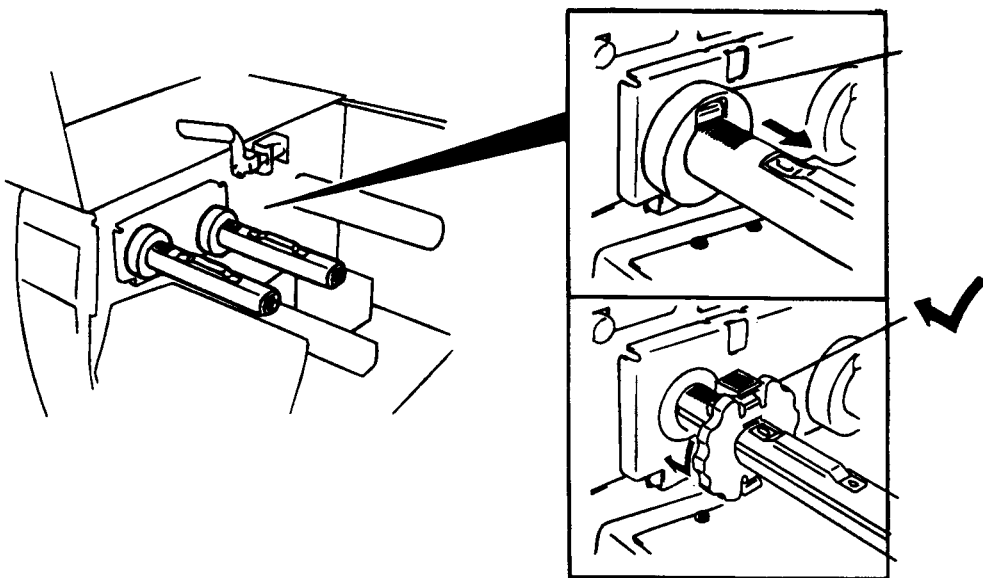

7. LOADING THE RIBBON

7. LOADING THE RIBBON

# 7. LOADING THE RIBBON

There are two types of media available for printing on, these are standard media and direct thermal media (a chemically treated surface). **DO NOT LOAD** a ribbon when using a direct thermal media.

1. When using a narrow width ribbon, slide the ribbon stoppers along the shafts to a position where the ribbon will be centered when it is fitted. When changing from a narrow width to a wider one rotate the ribbon stoppers by 90°, push them back to the correct position and then rotate back to lock.

**NOTE:** When attaching the ribbon stoppers, fit them to the shafts with the pinchers facing into the printer.

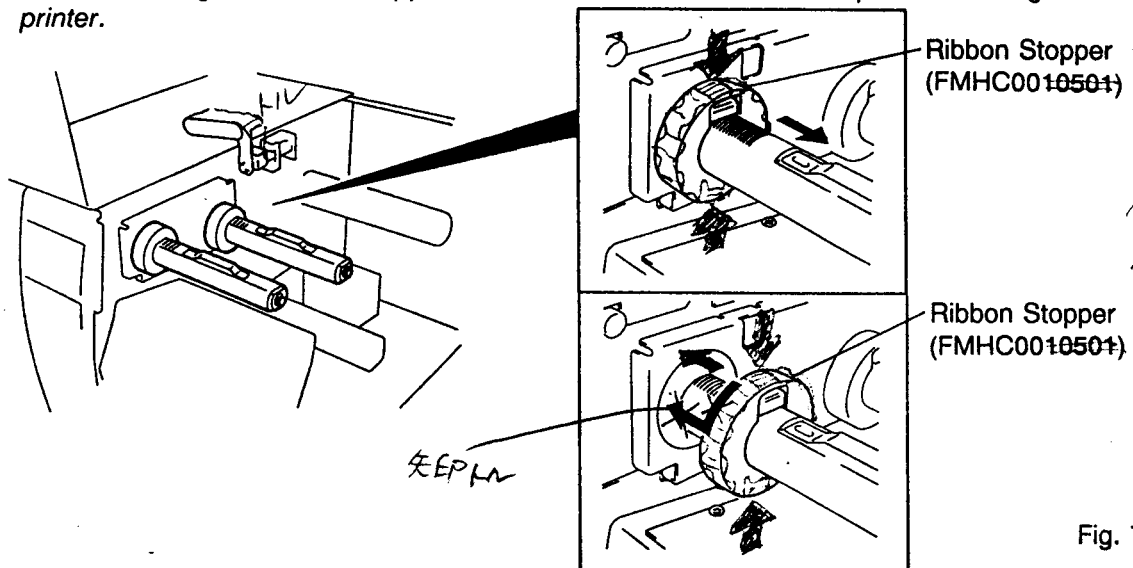

Fig. 7-1

2. Leaving plenty of slack between the spools, fit the ribbon as shown below. When the ribbon is fitted it must be positioned over the ribbon sensor.
3. Wind both shafts towards each other to tighten the ribbon.

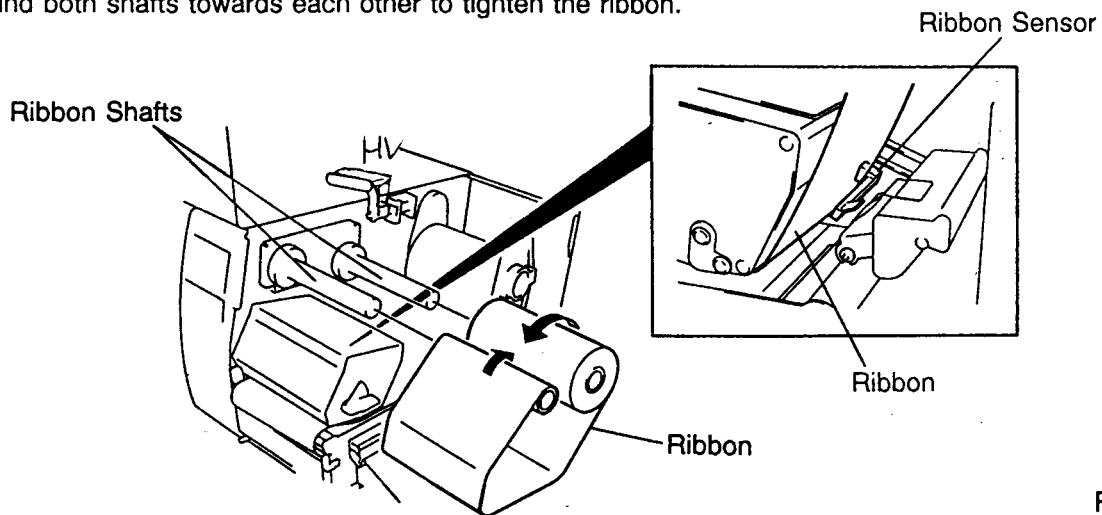

Fig. 7-2

4. Reset the ribbon shaft holder plate by aligning it with the ribbon shaft.
5. Turn the head lever clockwise to lower the print head.
6. Close the top cover.

PCMCIA

8. INSERTING THE OPTIONAL FLASH MEMORY CARD

PCMCIA

8. INSERTING THE OPTIONAL FLASH MEMORY CARD

8. INSERTING THE OPTIONAL FLASH MEMORY CARD

WARNING:

PCMCIA

Turn the power OFF when inserting or removing the flash memory card.

CAUTION:

PCMCIA

To protect memory-cards, discharge static electricity from your body by touching the printer rear cover prior to touching the memory cards.

1. Turn the power off.
2. Insert the flash memory card into the memory card slot on the rear of the printer.
3. Turn the power on.

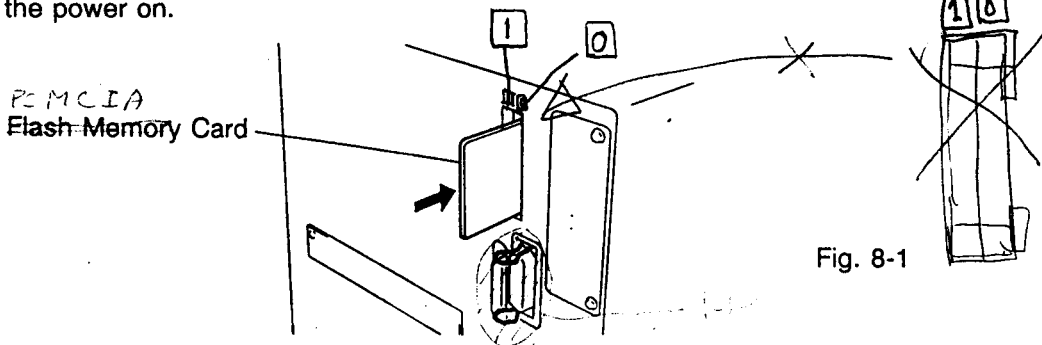

- NOTES:
1. Be sure to protect a flash memory card when not in use in the printer by putting it in its protective cover.
  2. Do not subject the card to any shocks or excessive forces.
  3. Do not expose the card to extremes of heat by either storing in direct sunlight or close to a heater.
  4. Do not expose the card to excessive humidity by wiping it with a wet cloth or storing it in a damp place.
  5. Before inserting or removing the card, make sure that the power switch is turned off.

R11紙 E8-1

**9. CARE/HANDLING OF THE MEDIA AND RIBBON****9. CARE/HANDLING OF THE MEDIA AND RIBBON****9. CARE/HANDLING OF THE MEDIA AND RIBBON****CAUTION :**

*Be sure to read carefully and understand the Supply Manual. Use only media and ribbon which meet specified requirements. Use of non-specified media and ribbon may shorten the head life and result in problems with bar code readability or print quality. All media and ribbon should be handled with care to avoid any damage to the media, ribbon or printer. Read the following guideline carefully.*

- Do not store the media and ribbon for longer than the manufactures recommended shelf life.
- Store media rolls on the flat end, do not store them on the curved sides as this might flatten that side causing erratic media advance and poor print quality.
- Store the media in plastic bags and always reseal after opening. Unprotected media can get dirty and the extra abrasion from the dust and dirt particles will shorten the print head life.
- Store the media and ribbon in a cool, dry place. Avoid areas where they would be exposed to direct sunlight, high temperature, high humidity, dust or gas.
- The thermal paper used for direct thermal printing must not have the specifications which exceed Na<sup>+</sup> 800 ppm, K<sup>+</sup> 250 ppm and CL<sup>-</sup> 500 ppm.
- Some ink used on pre-printed labels may contain ingredients which shorten the print head's product life. Do not use labels pre-printed with ink which contain hard substances such as carbonic calcium (CaCO<sub>3</sub>) and kaolin (Al<sub>2</sub>O<sub>3</sub>, 2SiO<sub>2</sub>, 2H<sub>2</sub>O).

For further information please contact your local distributor or your media and ribbon manufacturer.

## 10. GENERAL MAINTENANCE

### 10.1 Cleaning

To help retain the high quality and performance of your printer it should be regularly cleaned. The greater the usage of the printer, the more frequent the cleaning. (i.e. low usage = weekly : high usage = daily).

A print head cleaner is not enclosed with the printer, so please inquire at your local distributor.

1. Turn the power off.
2. Open the top cover.
3. Turn the head lever to raise the print head.
4. Remove the ribbon and media.
5. Clean the element of print head with print head cleaner.
6. Wipe the platen, feed roller and pinch roller with a cleaner moistened with alcohol. Remove dust or foreign substances from the internal part of the printer, if any.

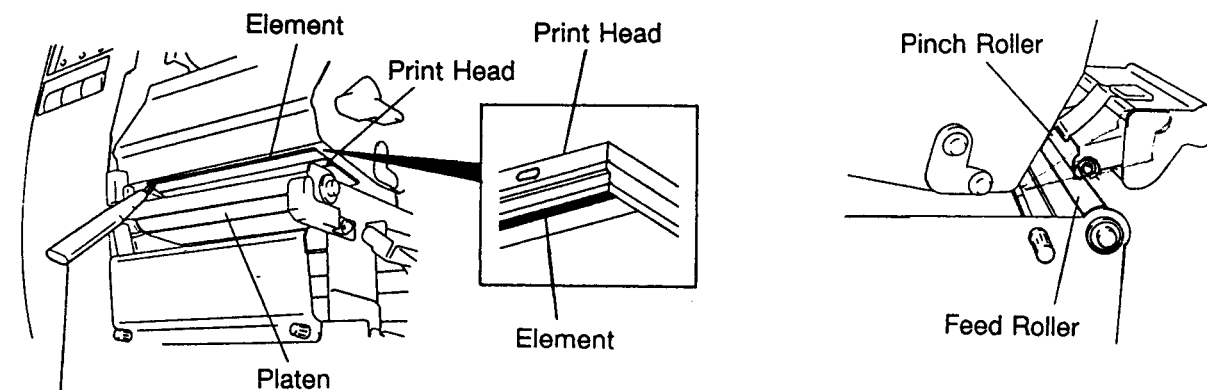

Print Head Cleaner  
(24089500013)

Fig. 10-1

- WARNING:**
1. Be sure to disconnect the power cord prior to performing any maintenance.
  2. Do not use any tool that may damage the print head.
  3. DO NOT POUR WATER directly onto the printer.

### 10.2 Covers and Panels

The covers should be cleaned by wiping with a dry cloth or a cloth slightly dampened with a mild detergent solution.

**NOTE:** Clean the printer cover with an electrostatic free cleaner for automated office equipment.

- WARNING:**
1. DO NOT POUR WATER directly onto the printer.
  2. DO NOT APPLY cleaner or detergent directly onto any cover or panel.
  3. NEVER USE THINNER OR OTHER VOLATILE SOLVENT on the plastic covers.
  4. DO NOT clean the panel covers or the supply window with alcohol as it may cause them to discolor, loose their shape or develop structural weakness.

## 10. GENERAL MAINTENANCE

## 10.3 Removing Jammed Paper

## 10.3 Removing Jammed Paper

1. Turn the power off.
2. Open the top cover.
3. Turn the head lever to position ③, then release the ribbon shaft holder plate.
4. Remove the black screw to detach the media guide plate. (See Fig. 10-2.)
5. Remove the ribbon and media.
6. Remove the jammed paper. DO NOT USE any sharp implement or tool as these could damage the printer.
7. Clean the print head and platen, then remove any further dust or foreign substances.
8. Place the portion ② of the media guide plate on the media sensor. Secure the media guide plate with the ~~black screw~~.

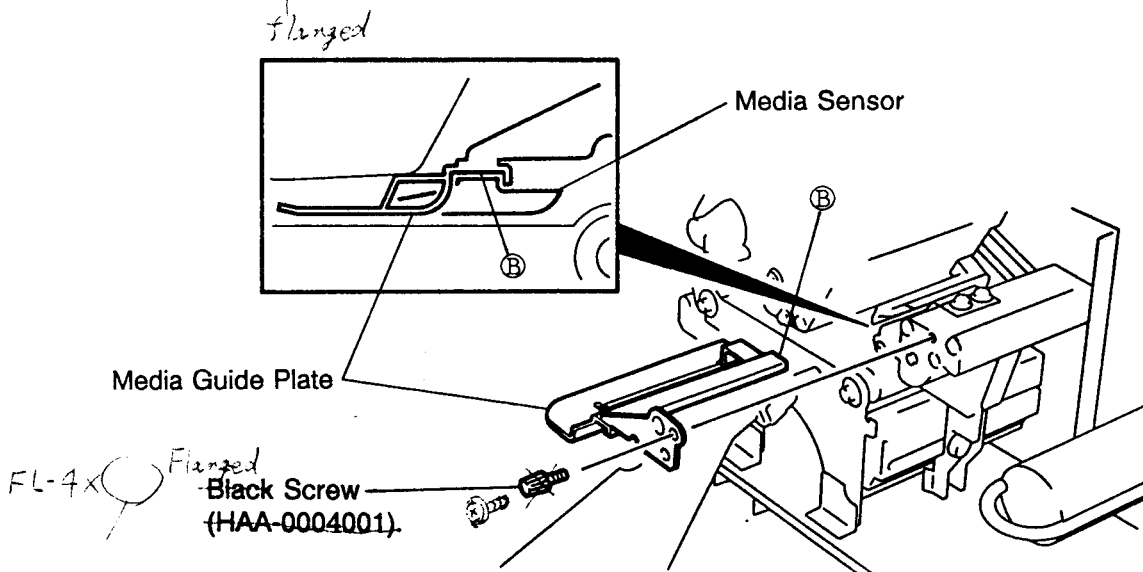

Fig. 10-2

9. Paper jams in the cutter unit can be caused by wear or residual glue from label stock on the cutter. Do not use none specified media in the cutter. If you get frequent jams in the cutter contact your Authorized Service representative.

■ Cleaning the Cutter Unit

**WARNING:** 1. Be sure to turn the power off before cleaning the cutter unit.  
 2. The cutters are sharp and care should be taken not to injure yourself when cleaning.

1. Loosen two screws and remove the cutter cover.
2. Remove the white screw and media guide.
3. Remove the jammed paper and trash.
4. Clean the cutter with dry cloth.

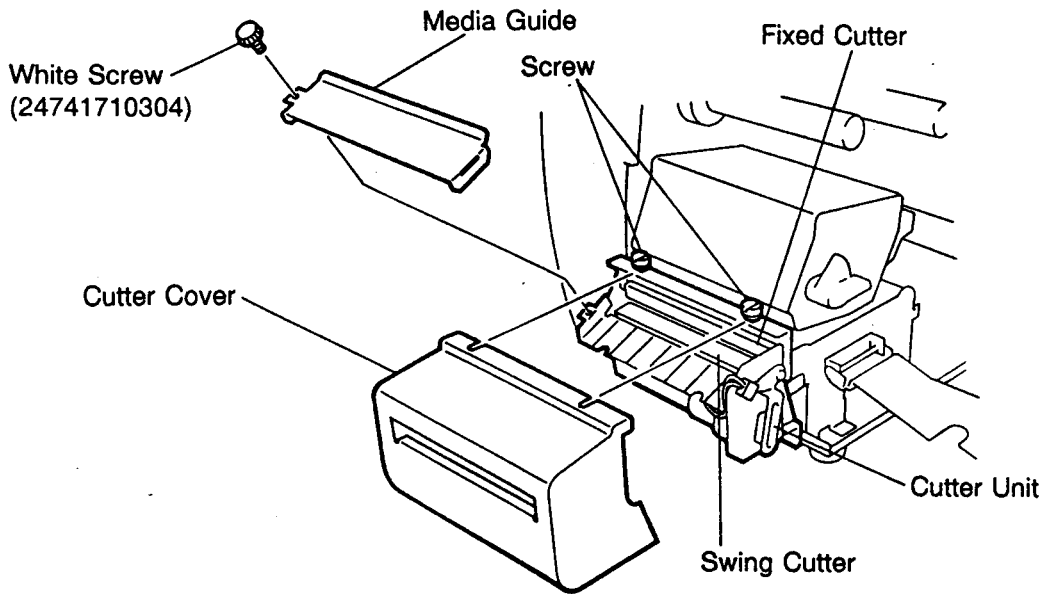

Fig. 10-3

5. Assembling is reverse order of removal.

オプションカッターには、スイングカッターとロータリーカッターの2種類があります。ここではスイングカッターでの清掃例を紹介します。

形状は異なりますが清掃方法は同様に行ないます。



10. GENERAL MAINTENANCE

10.4 Threshold Setting

10.4 Threshold Setting

For the printer to maintain a constant print position it uses the feed gap sensor to detect the gap between labels by measuring the amount of light passing through the media. When the media is pre-printed, the darker (or more dense) inks can interfere with this process causing paper jammed errors. To get around this problem a minimum threshold can be set for the sensor in the following way.

Threshold setting procedure

別紙に変更

- ✓ ① Turn the power on.
- ✓ ② Load the pre-printed label. (Any position)
- ✓ ③ Press the **PAUSE** key once.
- ④ Hold down the **PAUSE** key for more than 3 seconds and it will begin to feed. After it has fed the 2 label, release the **PAUSE** key.
- ⑤ Press the **RESTART** key for ON LINE mode.
- ⑥ Threshold setting is now completed.

**NOTES:** 1. If the **PAUSE** key is not held down for more than 3 seconds in PAUSE mode the threshold will not be set.  
 2. If the **PAUSE** key is released before 2 labels have been issued the setting may not be correct and will have to be re-set.

Auto Ribbon Saving Mode

Auto ribbon saving function is activated when ~~it is selected by DIP switch (Refer to page 4-1)~~ and no print area extends more than 20 mm.

~~NOTES: \* To activate ribbon saving function at a speed of 10"/sec., the no print area should extend more than 30 mm.~~

\* According to the relation between the outer diameter of rewound ribbon and print speed, ribbon loss per saving varies as follows:

Print speed	Ribbon loss
3"/sec.	Approx. 5 mm
5" 6"/sec.	Approx. 10 mm
8" 10"/sec.	Approx. 20 mm

Auto ribbon saving 機能については、最新の TOSHIBA TEC 販売代理店に相談して下さい。

## 5.5 THRESHOLD SETTING (PREPRINTED LABEL)

### 5.5.1 Outline of Threshold Setting

When a label is printed, the printer detects the gap between the labels using the transmissive sensor, and correct the print position automatically to obtain constant print position. When the preprinted label is used, however, some inks may prevent proper positioning correction. In this case, determine the transmissive sensor threshold by key operation and store the value in the non-volatile memory (EEPROM).

A constant print position on the preprinted labels can also be obtained when printing on a preprinted label since the print position is always corrected using the threshold stored in the non-volatile memory (EEPROM) by selecting "3: Transmissive Sensor (when using the preprinted label)" for the sensor type of the Issue Command.

When a label is printed by detecting the black mark on the back of the label, the reflective rate variation of a place other than the black mark may prevent the proper positioning correction. In this case, determine the reflective sensor threshold by key operation and store the value in the non-volatile memory (EEPROM).

A constant print position can also be obtained when printing on a tag since the print position is always corrected using the threshold stored in the non-volatile memory (EEPROM) by selecting "4: Reflective Sensor (when using a manual threshold value)" for the sensor type of the Issue Command.

### 5.5.2 Threshold Setting Operation Example

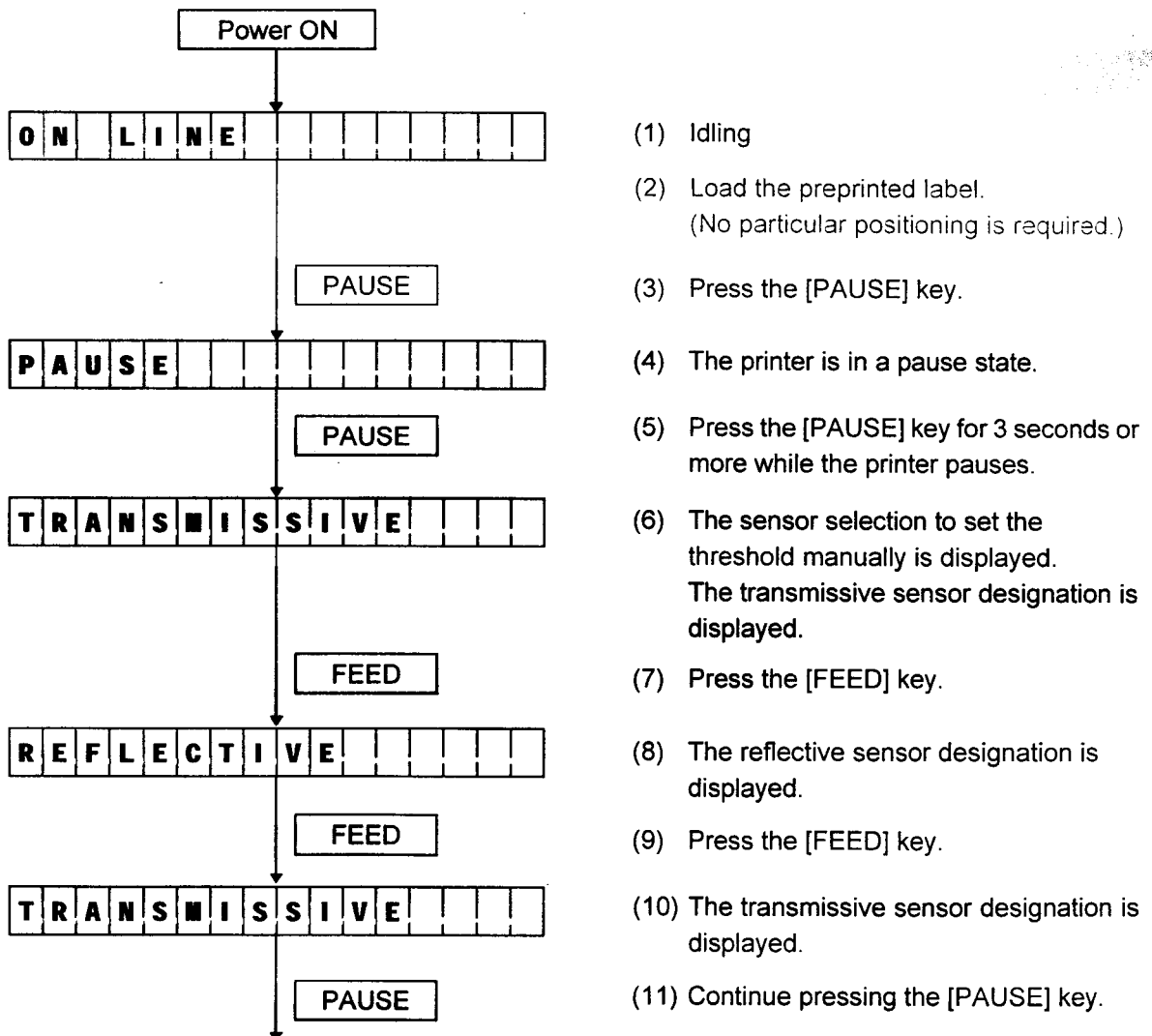

87 56

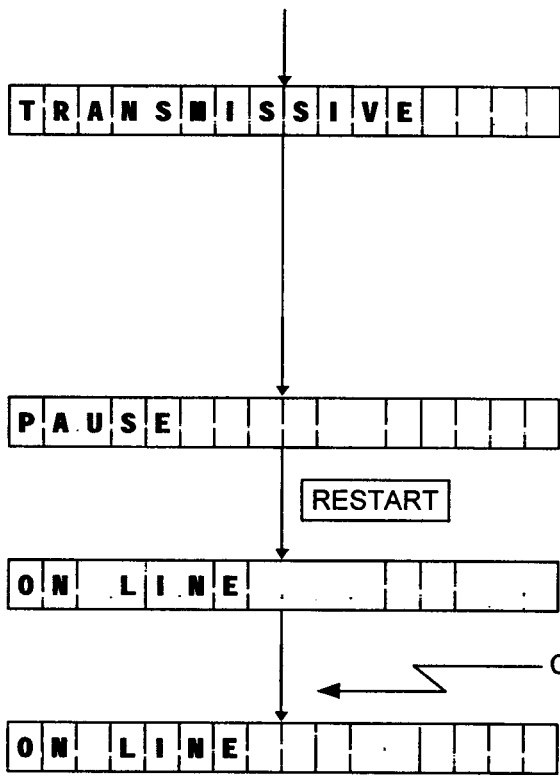

- (12) The printer feeds the label until the [PAUSE] key is released.
- (13) When the [PAUSE] key is released after more than 1.5 sheets of the label are fed, the printer stops feeding the label. (Threshold setting for the selected sensor is completed.)
- (14) Press the [RESTART] key.
- (15) Idling
- (16) The label is printed according to the command issued from the PC.

<Supplementary Explanation>

- (1) When the [PAUSE] key is released within 3 seconds while printer pauses, the [PAUSE] key is invalid.
- (2) When the threshold is programmed, 1.5 sheets of the label should be fed. (If the label is not fed by the above amount, the threshold may not be properly programmed. In this case, reprogramming is required.)
- (3) When the [PAUSE] key is pressed for 3 seconds or more in a head-up state, the [PAUSE] key is invalid.
- (4) During a label feed, an error including the paper end, ribbon end or cutter error is not detected.

(5) When the proper print position is not obtained after threshold programming, the transmissive sensor may be improperly adjusted. In this case, readjust the transmissive sensor in system mode, program the threshold.  
 When the backing paper of the label is too-thick, the transmissive sensor should be readjusted.  
 In addition, make sure that "3: Transmissive sensor (when-using the preprinted label)" or "4: Reflective sensor (when using a manual threshold value)" is selected for sensor type of the Feed Command and the Issue Command.

## 11. TROUBLESHOOTING

**WARNING:**

If you cannot solve a problem with the following solutions, do not attempt to repair it yourself. Turn the power off, unplug the printer, then contact your Authorized Service representative for assistance.

Error Message	Problem	Solution
PAPER JAM ****	<ol style="list-style-type: none"> <li>The media is not fitted correctly.</li> <li>The media path is jammed and does not feed smoothly.</li> <li>The installed media type does not match the selected sensor.</li> <li>The black mark position on the media does not match the sensor position.</li> <li>The installed media size is different from the programmed size.</li> <li>The feed gap sensor cannot see the difference between the print area and the gap.</li> </ol>	<ol style="list-style-type: none"> <li>Re-fit the media correctly. → Press the <b>RESTART</b> key.</li> <li>Remove the cause of the jam and replace the media correctly. → Press the <b>RESTART</b> key.</li> <li>Turn the power off then on again. Select the correct sensor. → Feed the media.</li> <li>Adjust the sensor position. → Press the <b>RESTART</b> key.</li> <li>Turn the power off then on again. Set the correct media size. → Feed the media.</li> <li>Set the threshold (see page 10-4). Else Turn the power off and call your Authorized Service representative.</li> </ol>
HEAD OPEN ****	Feed or printing has been attempted while the print head is raised.	Lower the print head. → Press the <b>RESTART</b> key.
NO PAPER ****	The media has run out.	Load new media. → Press the <b>RESTART</b> key.
NO RIBBON ****	The ribbon has run out.	Load a new ribbon. → Press the <b>RESTART</b> key.
REWIND FULL ****	Too much backing paper or media is wound on the internal take-up spool.	Remove the backing paper or media from the internal take-up spool. Then press the <b>RESTART</b> key.

Error Message	Problem	Solution
EXCESS HEAD TEMP	The print head is too hot.	Turn the power off and decrease the print head temperature.
RIBBON ERROR ****	There is a fault with the ribbon sensor.	Turn the power off. Contact your Authorized Service representative.
CUTTER ERROR ****	Media is jammed in the cutter.	Remove the jammed media and feed the undamaged media through the cutter. → Press the <b>RESTART</b> key. Else Turn the power off and contact your Authorized Service representative.
FLASH WRITE ERR.	An error has occurred when loading data onto a flash memory card.	<ol style="list-style-type: none"> <li>1. Turn the power off, re-seat the flash memory card and try again.</li> <li>2. Replace the flash memory card and retry.</li> <li>3. Turn the power off and contact your Authorized Service representative.</li> </ol>
FORMAT ERROR	An error has occurred while formatting a flash memory card.	<ol style="list-style-type: none"> <li>1. Turn the power off, re-seat the flash memory card and try again.</li> <li>2. Replace the flash memory card and retry.</li> <li>3. Turn the power off and contact your Authorized Service representative.</li> </ol>
FLASH CARD FULL	No more data can be saved in the flash memory card.	Replace the card with a new one and re-send data. (Only 1MB and 4MB cards can be used.)
COMMS ERROR	A communication error has occurred with the host.	Turn the power off then on again or press the <b>RESTART</b> key. Check the program data. → Call your Authorized Service representative if necessary.

Error Message	Problem	Solution
example) PC001 ; 0A00, ↑ Command error 0300, 2, 2	When an error is detected in a command 16 bytes of the command are displayed. (ESC, LF, NUL are not displayed.)	Correct the command and re-send it again.
Other Error Message	Hardware or software trouble.	Turn the power off then on again. If the problem still exists turn the power off and contact your Authorized Service representative.
<p><b>NOTE:</b> If an error is not cleared by pressing the <b>RESTART</b> key, the power must be switched off then on again. After the power has been switched off and on, all print data in the printer is cleared. **** denotes a remaining count of unprinted labels.</p>		

Problem	Solution
No print.	<ol style="list-style-type: none"> <li>1. Check that the media and the ribbon is loaded correctly.</li> <li>2. Check whether the print head is set correctly or not.</li> <li>3. Check the cabling between the printer and the host.</li> </ol>
Dots missing in the print.	Dirty print head. → Clean the print head. Call your Authorized Service representative if necessary.
Unclear (or blurred) printing.	<ol style="list-style-type: none"> <li>1. Dirty print head. → Clean the print head.</li> <li>2. Bad or faulty ribbon. → Replace ribbon.</li> <li>3. Poor media quality. → Change media type.</li> </ol>
Power does not come on.	<ol style="list-style-type: none"> <li>1. Plug power cord into an AC socket.</li> <li>2. Check the circuit breakers or fuses.</li> <li>3. Plug another appliance into the AC socket to check if there is power supplied.</li> </ol> Call your Authorized Service representative if necessary.
Printer does not cut.	Check for a paper jam in the cutter. Call your Authorized Service representative if necessary.
You see a raised nap where the media has been cut.	<ol style="list-style-type: none"> <li>1. Clean the cutter blades.</li> <li>2. The blades are worn. → Call your Authorized Service representative.</li> </ol>

**TEC**  
TOSHIBA TEC CORPORATION

6ヶ国語

 PRINTED IN JAPAN  
EO1-33007