

TEST REPORT

Report No.: 19070256HKG-002

HeathCo LLC

Application For Certification
(Original Grant)

FCC ID: BJ4-WLTX302-A

IC: 3984A-WLTX302A

Transmitter

Prepared and Checked by:

Approved by:

Signed On File
Wong Cheuk Ho, Herbert
Lead Engineer

Wong Kwok Yeung, Kenneth
Senior Lead Engineer
Date: August 02, 2019

Intertek's standard Terms and Conditions can be obtained at our website <http://www.intertek.com/terms/>.

The test report only allows to be revised within the retention period unless further standard or the requirement was noticed.

This report is for the exclusive use of Intertek's Client and is provided pursuant to the agreement between Intertek and its Client. Intertek's responsibility and liability are limited to the terms and conditions of the agreement. Intertek assumes no liability to any party, other than to the Client in accordance with the agreement, for any loss, expense or damage occasioned by the use of this report. Only the Client is authorized to permit copying or distribution of this report and then only in its entirety. Any use of the Intertek name or one of its marks for the sale or advertisement of the tested material, product or service must first be approved in writing by Intertek. The observations and test results in this report are relevant only to the sample tested. This report by itself does not imply that the material, product, or service is or has ever been under an Intertek certification program.

© 2017 Intertek

TEST REPORT

GENERAL INFORMATION

Grantee:	HeathCo LLC
Grantee Address:	2445 Nashville Road, Bowling Green, KY. 42101
Contact Person:	Jeff Bessinger
Tel:	270-846-8271
Fax:	N/A
e-mail:	jbessinger@heathcollc.com
Manufacturer:	HeathCo LLC
Manufacturer Address:	2445 Nashville Road, Bowling Green, KY. 42101
Brand Name:	Heath/Zenith, Heath Zenith, Notifi, Style Selections, Utilitech, Hampton Bay, Secur360, Portfolio, Secure Home, ACE, Defiant, Home Decorators
Model / HVIN:	WLTX-302-A
PMN:	WLTX-302-A
Type of EUT:	Transmitter
Description of EUT:	315MHz Battery Operated Wireless Transmitter
Serial Number:	N/A
FCC ID / IC:	BJ4-WLTX302-A / 3984A-WLTX302A
Date of Sample Submitted:	July 16, 2019
Date of Test:	July 16, 2019 to August 02, 2019
Report No.:	19070256HKG-002
Report Date:	August 02, 2019
Environmental Conditions:	Temperature: +10 to 40°C Humidity: 10 to 90%
Conclusion:	Test was conducted by client submitted sample. The submitted sample as received complied with the 47 CFR Part 15 / RSS-210 Issue 9 Certification.

TEST REPORT

SUMMARY OF TEST RESULT

Test Specification	Reference	Results
Transmitter Field Strength, Bandwidth and Timing Requirement	15.231(a), (b), (c) / RSS-210 A1.1.1	Pass

The equipment under test is found to be complying with the following standards:

FCC Part 15, October 1, 2017 Edition

RSS-210 Issue 9, August 2016

RSS-Gen Issue 5 + Amendment 1, March 2019

Note: 1. The EUT uses a permanently attached antenna which, in accordance to section 15.203, is considered sufficient to comply with the provisions of this section.
2. Pursuant to FCC part 15 Section 15.215(c), the 20 dB bandwidth of the emission was contained within the frequency band designated (mentioned as above) which the EUT operated. The effects, if any, from frequency sweeping, frequency hopping, other modulation techniques and frequency stability over excepted variations in temperature and supply voltage were considered.

TEST REPORT

TABLE OF CONTENTS

1.0 GENERAL DESCRIPTION 5

 1.1 Product Description5

 1.2 Related Submittal(s) Grants5

 1.3 Test Methodology.....5

 1.4 Test Facility5

2.0 SYSTEM TEST CONFIGURATION..... 6

 2.1 Justification.....6

 2.2 EUT Exercising Software.....6

 2.3 Special Accessories6

 2.4 Measurement Uncertainty.....6

 2.5 Support Equipment List and Description.....6

3.0 EMISSION RESULTS..... 7

 3.1 Field Strength Calculation7

 3.2 Radiated Emission Configuration Photograph.....8

 3.3 Radiated Emission Data8

4.0 EQUIPMENT PHOTOGRAPHS 10

5.0 PRODUCT LABELLING..... 10

6.0 TECHNICAL SPECIFICATIONS 10

7.0 INSTRUCTION MANUAL..... 10

8.0 MISCELLANEOUS INFORMATION 11

 8.1 Measured Bandwidth12

 8.2 Discussion of Pulse Desensitization.....13

 8.3 Calculation of Average Factor13

 8.4 Emissions Test Procedures.....17

 8.5 Occupied Bandwidth.....20

9.0 CONFIDENTIALITY REQUEST 21

10.0 EQUIPMENT LIST 21

TEST REPORT

1.0 GENERAL DESCRIPTION

1.1 Product Description

The Equipment Under Test (EUT) is a 315MHz Battery Operated Wireless Transmitter. When the button of the EUT is activated, the corresponding 315MHz remote door bell receiver will sound. The EUT is powered by 12VDC (1 X 12V 23A battery).

Antenna Type: Internal, Integral

For electronic filing, the brief circuit description is saved with filename: descri.pdf.

1.2 Related Submittal(s) Grants

This is a single application for certification of a transmitter.

1.3 Test Methodology

Radiated emission measurements were performed according to the procedures in ANSI C63.10 (2013). All radiated measurements were performed in an 3m Chamber. Preliminary scans were performed in the 3m Chamber only to determine worst case modes. All radiated tests were performed at an antenna to EUT distance of 3 meters, unless stated otherwise in the “**Justification Section**” of this Application.

1.4 Test Facility

The 3m Chamber used to collect the radiated data is located at Workshop No. 3, G/F., World-Wide Industrial Centre, 43-47 Shan Mei Street, Fo Tan, Sha Tin, N.T., Hong Kong. This test facility and site measurement data have been placed on file with the FCC and IC No. 2042H.

TEST REPORT

2.0 SYSTEM TEST CONFIGURATION

2.1 Justification

The system was configured for testing in a typical fashion (as a customer would normally use it), and in the confines as outlined in ANSI C63.10 (2013).

The device was powered by 12VDC (1 X new 12V 23A) battery during test.

For maximizing emissions, the EUT was rotated through 360°, the antenna height was varied from 1 meter to 4 meters above the ground plane, and the antenna polarization was changed. This step by step procedure for maximizing emissions led to the data reported in Exhibit 3.0.

The unit was operated standalone and placed in the center of the turntable.

The equipment under test (EUT) was configured for testing in a typical fashion (as a customer would normally use it). The EUT was mounted to a plastic stand if necessary and placed on the wooden turntable, which enabled the engineer to maximize emissions through its placement in the three orthogonal axes.

2.2 EUT Exercising Software

There was no special software to exercise the device. Once the unit is powered up, it transmits the RF signal continuously.

2.3 Special Accessories

There are no special accessories necessary for compliance of this product.

2.4 Measurement Uncertainty

When determining of the test conclusion, the Measurement Uncertainty of test has been considered.

2.5 Support Equipment List and Description

N/A.

TEST REPORT

3.0 EMISSION RESULTS

Data is included of the worst case configuration (the configuration which resulted in the highest emission levels). A sample calculation, configuration photographs and data tables of the emissions are included.

3.1 Field Strength Calculation

The field strength is calculated by adding the Antenna Factor and Cable Factor, and subtracting the Amplifier Gain (if any), Average Factor (optional) from the measured reading. The basic equation with a sample calculation is as follows:

$$FS = RA + AF + CF - AG - AV$$

where FS = Field Strength in dB μ V/m

RA = Receiver Amplitude (including preamplifier) in dB μ V

CF = Cable Attenuation Factor in dB

AF = Antenna Factor in dB

AG = Amplifier Gain in dB

AV = Average Factor in dB

In the following table(s), the reading shown on the data table reflects the preamplifier gain. An example for the calculations in the following table is as follows:

$$FS = RR + LF$$

where FS = Field Strength in dB μ V/m

RR = RA - AG - AV in dB μ V

LF = CF + AF in dB

Assume a receiver reading of 52.0 dB μ V is obtained. The antenna factor of 7.4 dB and cable factor of 1.6 dB are added. The amplifier gain of 29 dB and average factor of 5 dB are subtracted, giving a field strength of 32 dB μ V/m. This value in dB μ V/m was converted to its corresponding level in μ V/m.

$$RA = 52.0 \text{ dB}\mu\text{V/m}$$

$$AF = 7.4 \text{ dB}$$

$$CF = 1.6 \text{ dB}$$

$$AG = 29.0 \text{ dB}$$

$$AV = 5.0 \text{ dB}$$

$$FS = RR + LF$$

$$FS = 18 + 9 = 27 \text{ dB}\mu\text{V/m}$$

$$RR = 18.0 \text{ dB}\mu\text{V}$$

$$LF = 9.0 \text{ dB}$$

$$\text{Level in } \mu\text{V/m} = \text{Common Antilogarithm } [(27 \text{ dB}\mu\text{V/m})/20] = 22.4 \mu\text{V/m}$$

TEST REPORT

3.2 Radiated Emission Configuration Photograph

The worst case in radiated emission was found at 315.000 MHz

For electronic filing, the worst case radiated emission configuration photographs are saved with filename: radiated photos.pdf.

3.3 Radiated Emission Data

The data on the following page lists the significant emission frequencies, the limit and the margin of compliance. Numbers with a minus sign are below the limit.

Judgment: Passed by 7.1 dB

TEST REPORT

RADIATED EMISSIONS

Model: WLTX-302-A

Date of Test: August 02, 2019

Worst-Case Operating Mode: Transmitting

Table 1
Pursuant to FCC Part 15 Section 15.231(a) / RSS-210 A1.1 Requirement

Polarization	Frequency (MHz)	Reading (dBµV)	Pre-Amp (dB)	Antenna factor (dB)	Average Factor (dB)	(Average) Net at 3m (dBµV/m)	Average Limit at 3m (dBµV/m)	Margin (dB)
H	315.000	73.4	16	23.0	11.9	68.5	75.6	-7.1
H	630.002	25.6	16	29.0	11.9	26.7	55.6	-28.9
V	945.008	25.8	16	33.0	11.9	30.9	55.6	-24.7
H	1260.000	56.3	34	26.1	11.9	36.5	55.6	-19.1
H	1575.000	54.8	34	27.2	11.9	36.1	54.0	-17.9
H	1890.000	55.6	34	27.2	11.9	36.9	55.6	-18.7
V	2205.000	52.8	34	29.4	11.9	36.3	54.0	-17.7
V	2520.000	52.2	34	30.4	11.9	36.7	55.6	-18.9
H	2835.000	52.0	34	30.4	11.9	36.5	54.0	-17.5
H	3150.000	50.5	34	31.9	11.9	36.5	55.6	-19.1

- NOTES:
1. Peak Detector Data unless otherwise stated.
 2. All measurements were made at 3 meters. Harmonic emissions not detected at the 3-meter distances were measured at 0.3-meter and an inverse proportional extrapolation was performed to compare the signal level to the 3-meter limit. No other harmonic emissions than those reported were detected at a test distance of 0.3-meter.
 3. Negative sign in the column shows value below limit.
 4. Horn antenna is used for the emission over 1000MHz.
 5. Emission (the row indicated by **bold italic**) within the restricted band meets the requirement of FCC Part 15 Section 15.205 / RSS-210 4.1.
 6. Measurement Uncertainty is ±5.3dB at a level of confidence of 95%.

TEST REPORT

4.0 EQUIPMENT PHOTOGRAPHS

For electronic filing, the photographs are saved with filename: external photos.pdf and internal photos.pdf.

5.0 PRODUCT LABELLING

For electronics filing, the FCC ID label artwork and the label location are saved with filename: label.pdf.

6.0 TECHNICAL SPECIFICATIONS

For electronic filing, the block diagram and schematic of the tested EUT are saved with filename: block.pdf and circuit.pdf respectively.

7.0 INSTRUCTION MANUAL

For electronic filing, a preliminary copy of the Instruction Manual is saved with filename: manual.pdf.

This manual will be provided to the end-user with each unit sold/leased in the United States and Canada.

TEST REPORT

8.0 MISCELLANEOUS INFORMATION

The miscellaneous information includes details of the test procedure and measured bandwidth / calculation of factor such as pulse desensitization and averaging factor (calculation and timing diagram).

Timing Plot – Pursuant to FCC Part 15 Section 15.231(a1)- A manually operated transmitter shall employ a switch that will automatically deactivate the transmitter within not more than 5 seconds of being released.

Result: Transmission Duration = 1.31096 seconds (within 5 seconds - Pass)

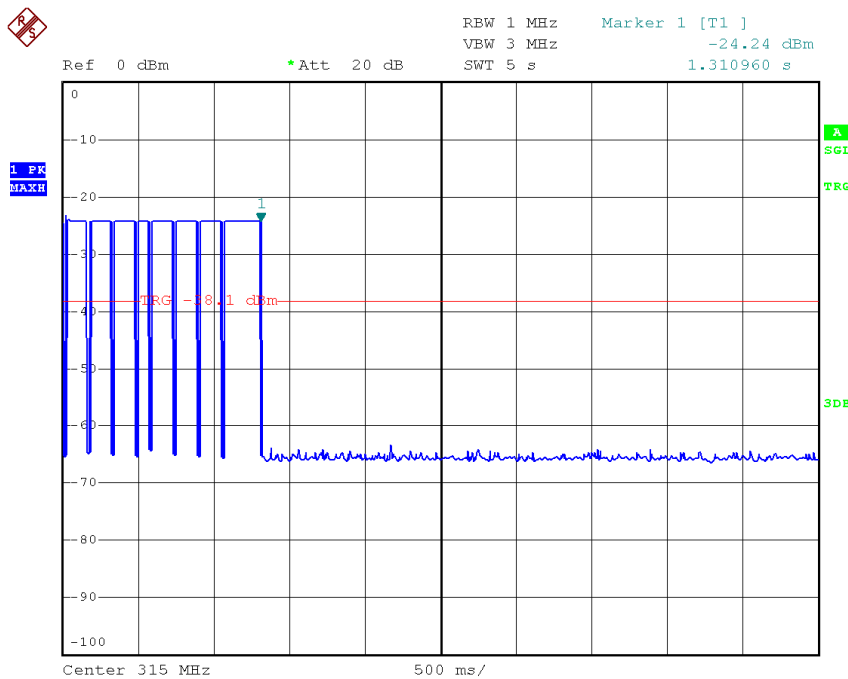

TEST REPORT

8.1 Measured Bandwidth

The plot shows the fundamental emission when modulated. From the plot, the bandwidth is observed to be 10.92kHz, at 20dBc where the bandwidth limit is 787.5kHz.

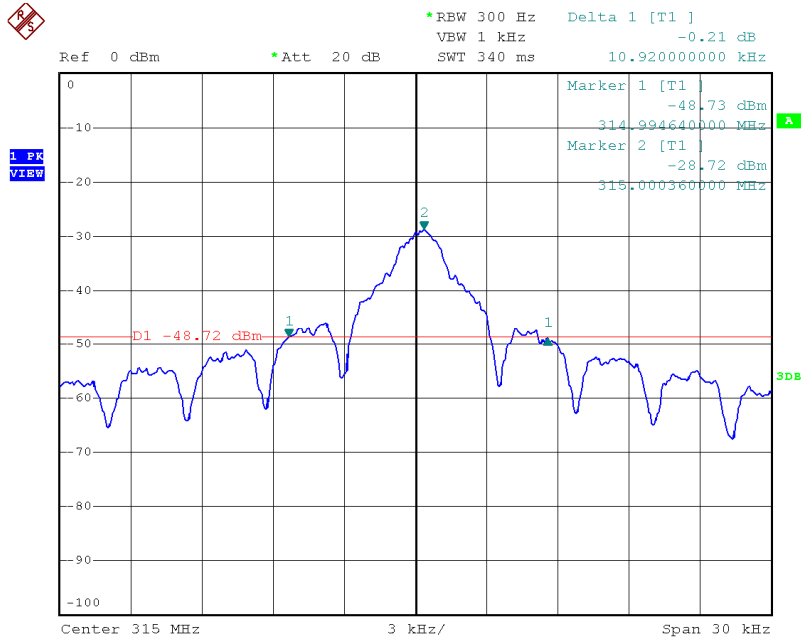

TEST REPORT

8.2 Discussion of Pulse Desensitization

Pulse desensitivity is not applicable for this device. The effective period (T_{eff}) is approximately 21.648ms for a digital "1" bit which illustrated on technical specification, with a resolution bandwidth (3dB) of 1MHz, so the pulse desensitivity factor is 0dB.

8.3 Calculation of Average Factor

The duty cycle is simply the on-time divided by the period:

The duration of one cycle = 100ms

Effective period of the cycle = $38 \times 0.32\text{ms} + 22 \times 0.6\text{ms} = 25.36\text{ms}$

DC = $25.36 / 100 = 0.2536\text{ms}$

Therefore, the averaging factor is found by $20\log(0.2536) = -11.9\text{dB}$.

TEST REPORT

AVERAGE FACTOR

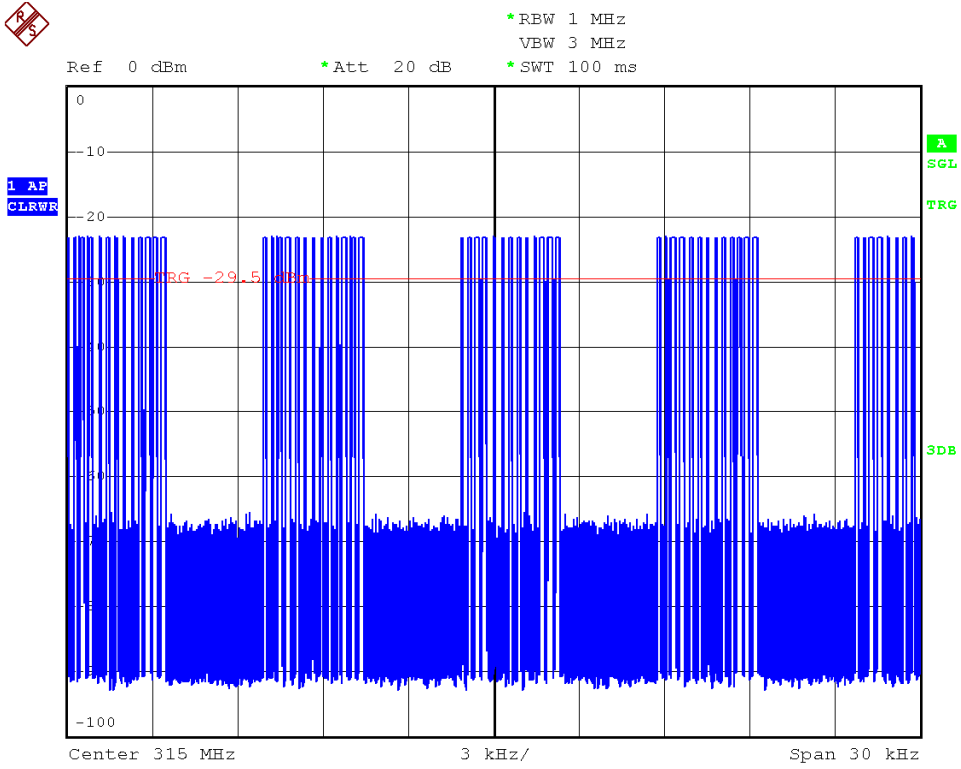

TEST REPORT

AVERAGE FACTOR

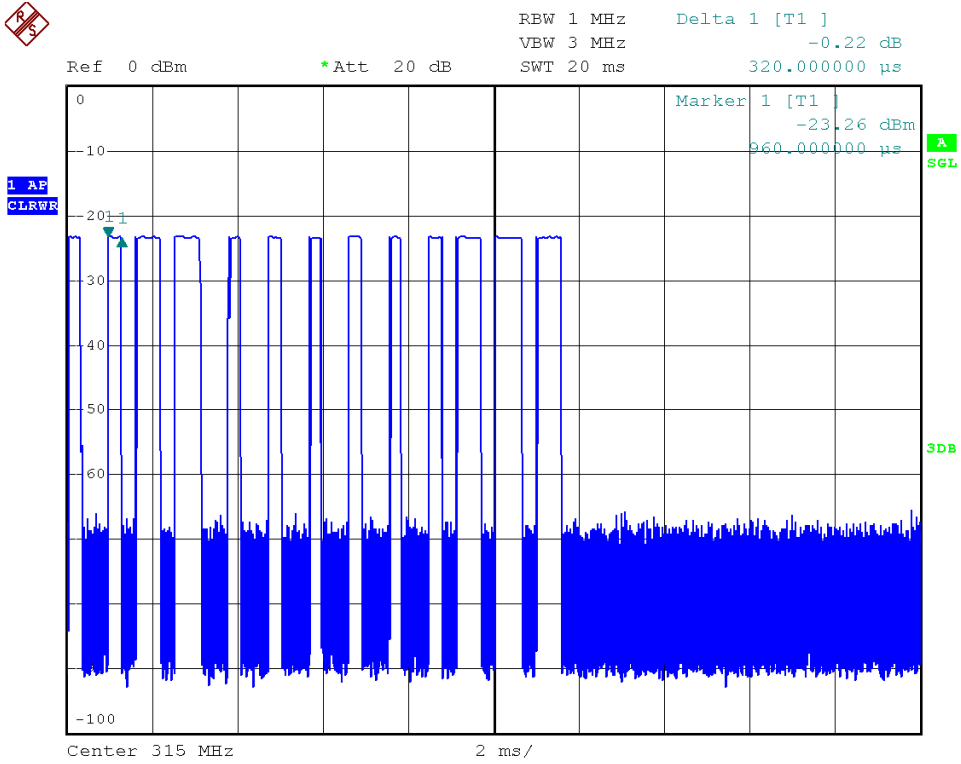

TEST REPORT

AVERAGE FACTOR

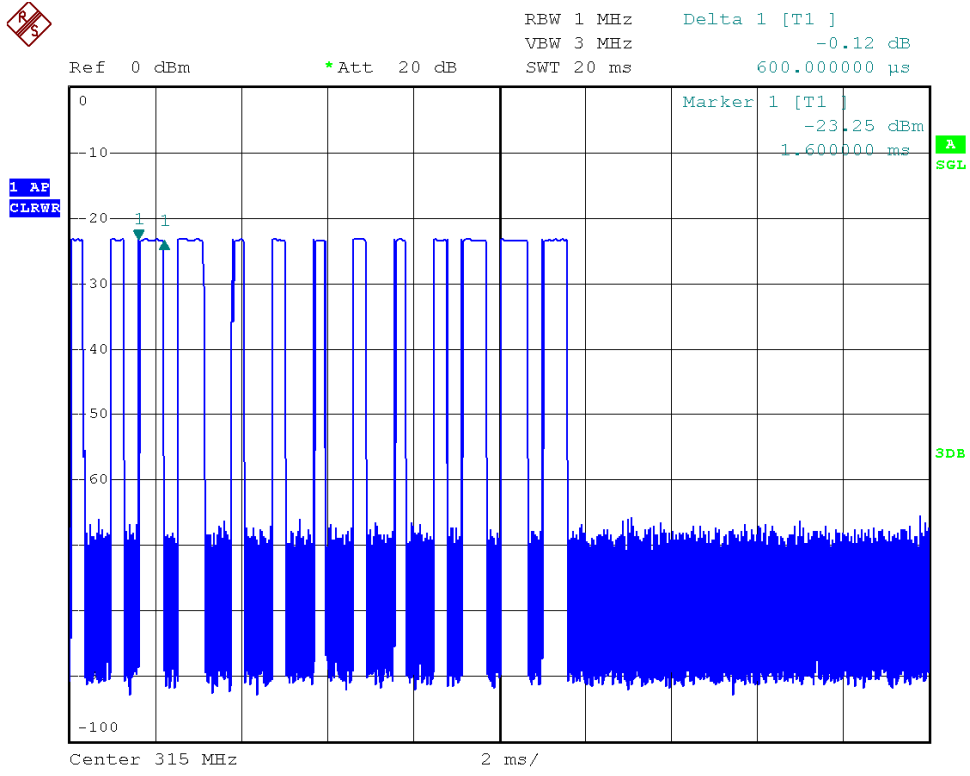

TEST REPORT

8.4 Emissions Test Procedures

The following is a description of the test procedure used by Intertek Testing Services Hong Kong Ltd. in the measurements of transmitter operating under the Part 15, Subpart C rules.

The transmitting equipment under test (EUT) is placed on a wooden turntable which is four feet in diameter and approximately 0.8m in height above the ground plane for emission measurement at or below 1GHz and 1.5m in height above the ground plane for emission measurement above 1GHz. During the radiated emissions test, the turntable is rotated and any cables leaving the EUT are manipulated to find the configuration resulting in maximum emissions. The EUT is adjusted through all three orthogonal axis to obtain maximum emission levels. The antenna height and polarization are also varied during the testing to search for maximum signal levels. The height of the antenna is varied from one to four meters.

Detector function for radiated emissions is in peak mode. Average readings, when required, are taken by measuring the duty cycle of the equipment under test and subtracting the corresponding amount in dB from the measured peak readings. A detailed description for the calculation of the average factor can be found in Exhibit 8.3.

The frequency range scanned is from the lowest radio frequency signal generated in the device which is greater than 9 kHz to the tenth harmonic of the highest fundamental frequency or 40 GHz, whichever is lower.

TEST REPORT

8.4 Emissions Test Procedures (cont'd)

The EUT is warmed up for 15 minutes prior to the test.

AC power to the unit is varied from 85% to 115% nominal and variation in the fundamental emission field strength is recorded. If battery powered, a new, fully charged battery is used.

Conducted measurements were made as described in ANSI C63.10 (2013).

The IF bandwidth used for measurement of radiated signal strength was 100 kHz or greater when frequency is below 1000 MHz. Where pulsed transmissions of short enough pulse duration warrant, a greater bandwidth is selected according to the recommendations of Hewlett Packard Application Note 150-2. A discussion of whether pulse desensitivity is applicable to this unit is included in this report (See Exhibit 8.1). Above 1000 MHz, a resolution bandwidth of 3 MHz is used.

Transmitter measurements are normally conducted at a measurement distance of three meters. However, to assure low enough noise floor in the forbidden bands and above 1 GHz, signals are acquired at a distance of one meter or less. All measurements are extrapolated to three meters using inverse scaling, unless otherwise reported. Measurements taken at a closer distance are so marked.

TEST REPORT

8.4.1 Radiated Emission Test Setup

The figure below shows the test setup, which is utilized to make these measurements.

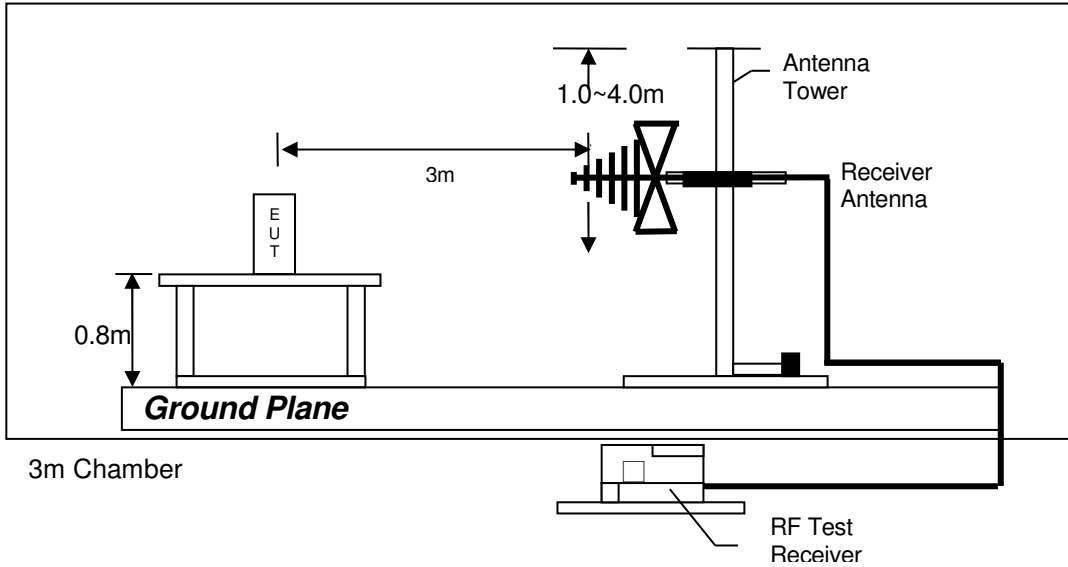

Test setup of radiated emissions up to 1GHz

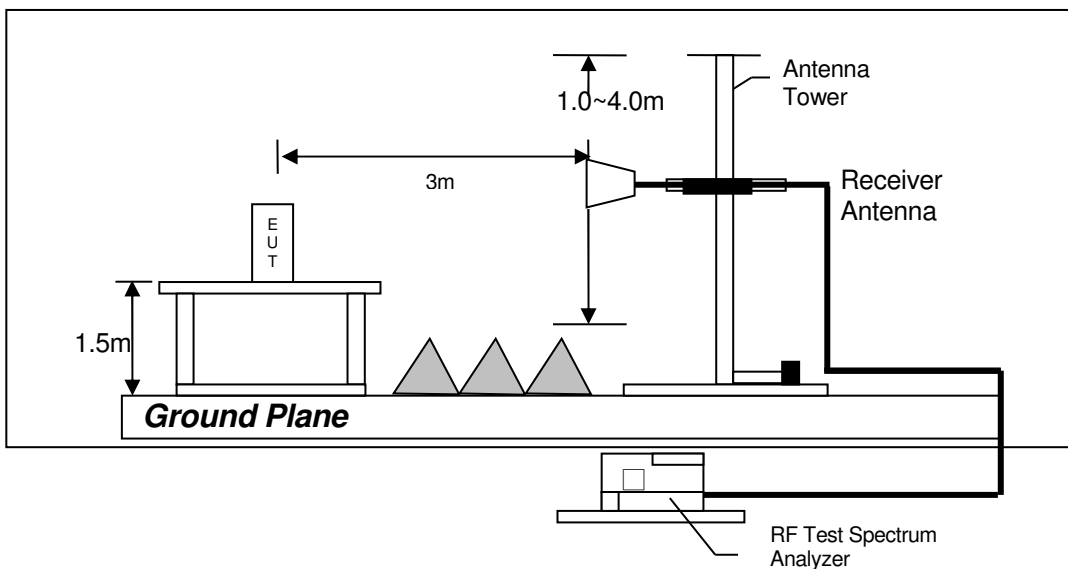

Test setup of radiated emissions above 1GHz

TEST REPORT

8.5 Occupied Bandwidth

Occupied Bandwidth Results:

Frequency (MHz)	Occupied Bandwidth (kHz)
315MHz	70.8

The plot shows the fundamental emission when modulated. From the plot, the bandwidth is observed to be 70.8kHz. The 99% Occupied bandwidth limit is 787.5kHz.

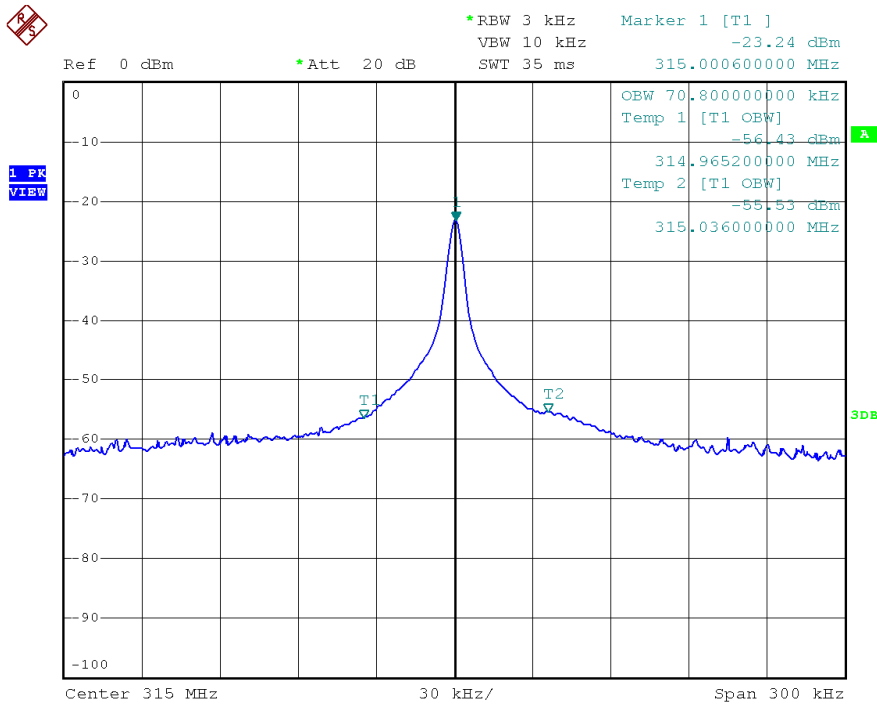

TEST REPORT

9.0 CONFIDENTIALITY REQUEST

For electronic filing, a preliminary copy of the confidentiality request is saved with filename: request.pdf.

10.0 EQUIPMENT LIST

1) Radiated Emissions Test

Equipment	EMI Test Receiver	Spectrum Analyzer	Biconical Antenna
Registration No.	EW-3156	EW-2253	EW-0571
Manufacturer	R&S	R&S	EMCO
Model No.	ESR26	FSP40	3104C
Calibration Date	November 19, 2018	November 27, 2018	February 27, 2018
Calibration Due Date	November 19, 2019	November 27, 2019	August 27, 2019

Equipment	Log Periodic Antenna	Double Ridged Guide Antenna	14m Double Shield RF Cable (20MHz to 6GHz)
Registration No.	EW-1042	EW-1133	EW-2505
Manufacturer	EMCO	EMCO	RADIALL
Model No.	3148	3115	nm / br5d / sma 14m
Calibration Date	April 04, 2018	November 29, 2018	October 27, 2018
Calibration Due Date	October 04, 2019	November 29, 2020	October 27, 2019

Equipment	RF Cable 14m (1GHz to 26.5GHz)	Active Loop H-field (9kHz to 30MHz)
Registration No.	EW-2781	EW-2313
Manufacturer	GREATBILLION	ELECTROMETRI
Model No.	SMA m/SHF5MPU /SMA m ra14m,26G	EM-6876
Calibration Date	October 27, 2018	March 08, 2018
Calibration Due Date	October 27, 2019	September 08, 2019

TEST REPORT

2) Bandedge Measurement

Equipment	Spectrum Analyzer
Registration No.	EW-2253
Manufacturer	R&S
Model No.	FSP40
Calibration Date	November 27, 2018
Calibration Due Date	November 27, 2019

END OF TEST REPORT