

KTL Test Report: 9R02232

Applicant: Heath Company
PO Box 90004
2701 Industrial Drive
Bowling Green, KY
42102

**Equipment Under Test:
(E.U.T.)** W-33A-TX

FCC ID: BJ4-61WRC33ATX

In Accordance With: **FCC Part 15, Subpart C**
For Low Power Transmitters Operating Periodically
In The Band 40.66 - 40.77 MHz And Above 70 MHz

Tested By: KTL Ottawa Inc.
3325 River Road, R.R. 5
Ottawa, Ontario K1V 1H2

Authorized By:

R. Grant, Wireless Group Manager

Date:

Total Number of Pages: 24

EQUIPMENT: W-33A-TX
FCC ID: BJ4-61WRC33ATX

Table of Contents

Section 1. Summary of Test Results..... 3

Section 2. Equipment Under Test (E.U.T.)..... 5

Section 3. Transmission Requirements 7

Section 4. Radiated Emissions 13

Section 5. Occupied Bandwidth..... 16

Section 6. Block Diagrams..... 20

Section 7. Test Equipment List..... 22

Annex A Restricted Bands.....A1

EQUIPMENT: W-33A-TX
FCC ID: BJ4-61WRC33ATX

Section 1. Summary of Test Results

Manufacturer: Heath Company
Model No.: W-33A-TX
Serial No.: None
Date Received In Laboratory: February 17, 2000
KTL Identification No.: Item #2

General: **All measurements are traceable to national standards.**

These tests were conducted on a sample of the equipment for the purpose of demonstrating compliance with Part 15, Subpart C, Paragraph 15.231. All tests were conducted using measurement procedure ANSI C63.4-1992. Radiated emissions are made on an open area test site. A description of the test facility is on file with the FCC.

- | | | | | | | |
|--|----------------------------|-------------------------------------|---------------------|----------------|--|--|
| <input checked="" type="checkbox"/> | New Submission | <input checked="" type="checkbox"/> | Production Unit | | | |
| <input type="checkbox"/> | Class II Permissive Change | <input type="checkbox"/> | Pre-Production Unit | | | |
| <table border="1" style="display: inline-table; vertical-align: middle;"><tr><td style="padding: 2px;">D</td><td style="padding: 2px;">S</td><td style="padding: 2px;">C</td></tr></table> | D | S | C | Equipment Code | | |
| D | S | C | | | | |

THIS TEST REPORT RELATES ONLY TO THE ITEM(S) TESTED.

THE FOLLOWING DEVIATIONS FROM, ADDITIONS TO, OR EXCLUSIONS FROM THE TEST SPECIFICATIONS HAVE BEEN MADE.
See " Summary of Test Data".



NVLAP LAB CODE: 100351-0

TESTED BY: _____ DATE: _____
Glen Westwell, Technologist

KTL Ottawa Inc. authorizes the above named company to reproduce this report provided it is reproduced in its entirety and for use by the company's employees only.

Any use which a third party makes of this report, or any reliance on or decisions to be made based on it, are the responsibility of such third parties. KTL Ottawa Inc. accepts no responsibility for damages, if any, suffered by any third party as a result of decisions made or actions based on this report.

This report applies only to the items tested.

EQUIPMENT: W-33A-TX
FCC ID: BJ4-61WRC33ATX

Summary Of Test Data

Name of Test	Paragraph Number	Results
Transmission Requirements	15.231(a)	Complies
Radiated Emissions	15.231(b)	Complies
Occupied Bandwidth	15.231(c)	Complies

Footnotes For N/A's:

Test Conditions:

Indoor Temperature: 24 °C
 Humidity: 20 %

Outdoor Temperature: -4 °C
 Humidity: 16 %

EQUIPMENT: W-33A-TX
FCC ID: BJ4-61WRC33ATX

Section 2. Equipment Under Test (E.U.T.)

General Equipment Information

Frequency Range:	315 MHz (Fixed)
Operating Frequency(ies) of Sample:	315 MHz
Type of Emission:	Pulse Code Modulation
Emission Designator:	653KL1D
Supply Power Requirement:	9 Vdc Battery
Duty Cycle Calculation:	<ol style="list-style-type: none">1. Pulse Period = 100 mSec ÷ 35.72 μS = 2799 pulses in a 100 mSec period.2. One Time Pulse Width = 17.44 μSec 2799 x 17.44 μSec = 48.8 mSec3. $20 \text{ Log } \frac{48.8\text{mSec}}{100\text{mSec}} = -6.2 \text{ dB}$

EQUIPMENT: W-33A-TX
FCC ID: BJ4-61WRC33ATX

Rationale for Compliance with Transmission Requirements

- 15.231(a)(1) :** The transmitter is deactivated immediately upon release of the transmit button.
- 15.231(a)(2) :** Not Applicable
- 15.231(a)(3) :** The transmitter does not transmit at regular intervals.
- 15.231(a)(4) :** Not Applicable

EQUIPMENT: W-33A-TX
FCC ID: BJ4-61WRC33ATX

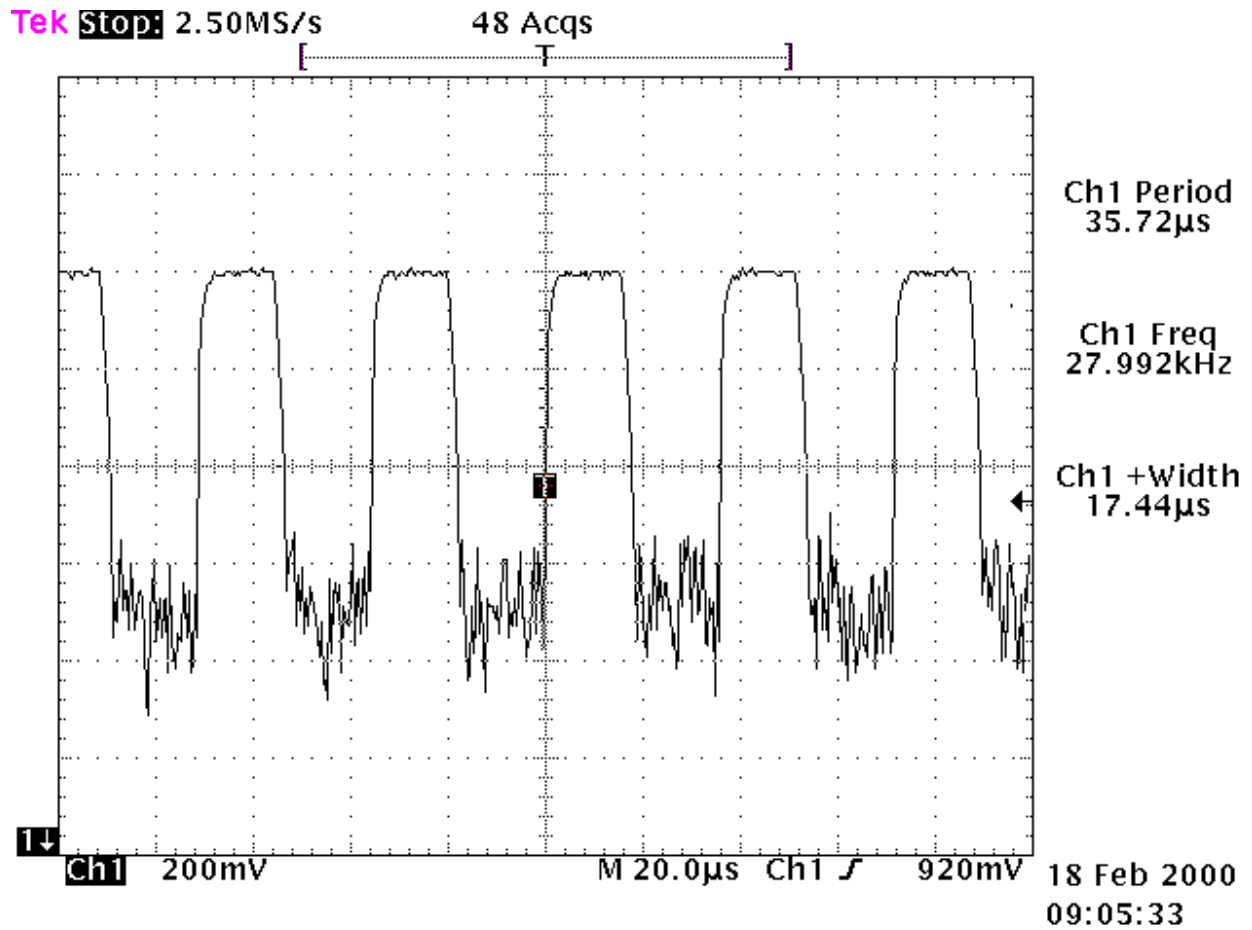

EQUIPMENT: W-33A-TX
FCC ID: BJ4-61WRC33ATX

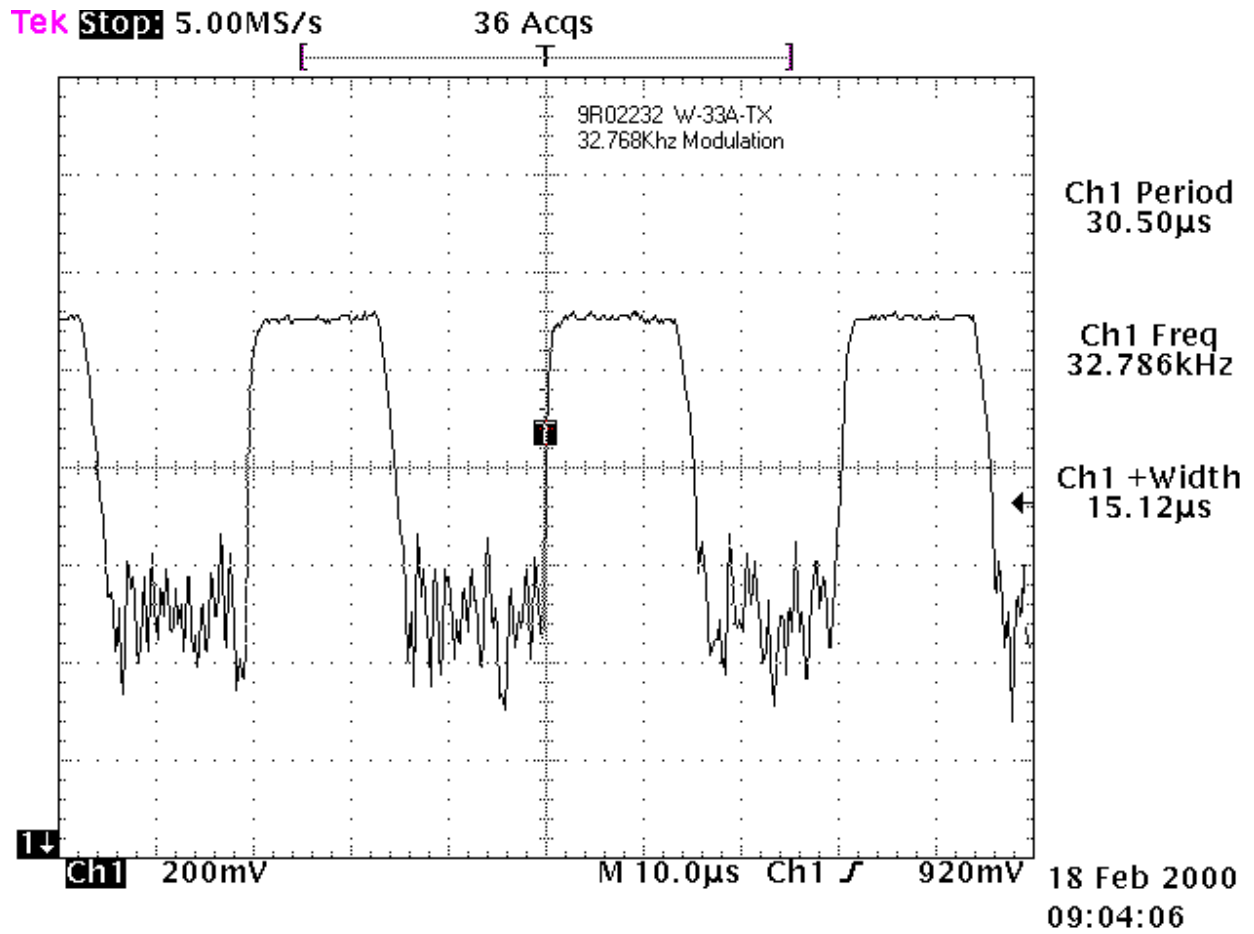

EQUIPMENT: W-33A-TX
FCC ID: BJ4-61WRC33ATX

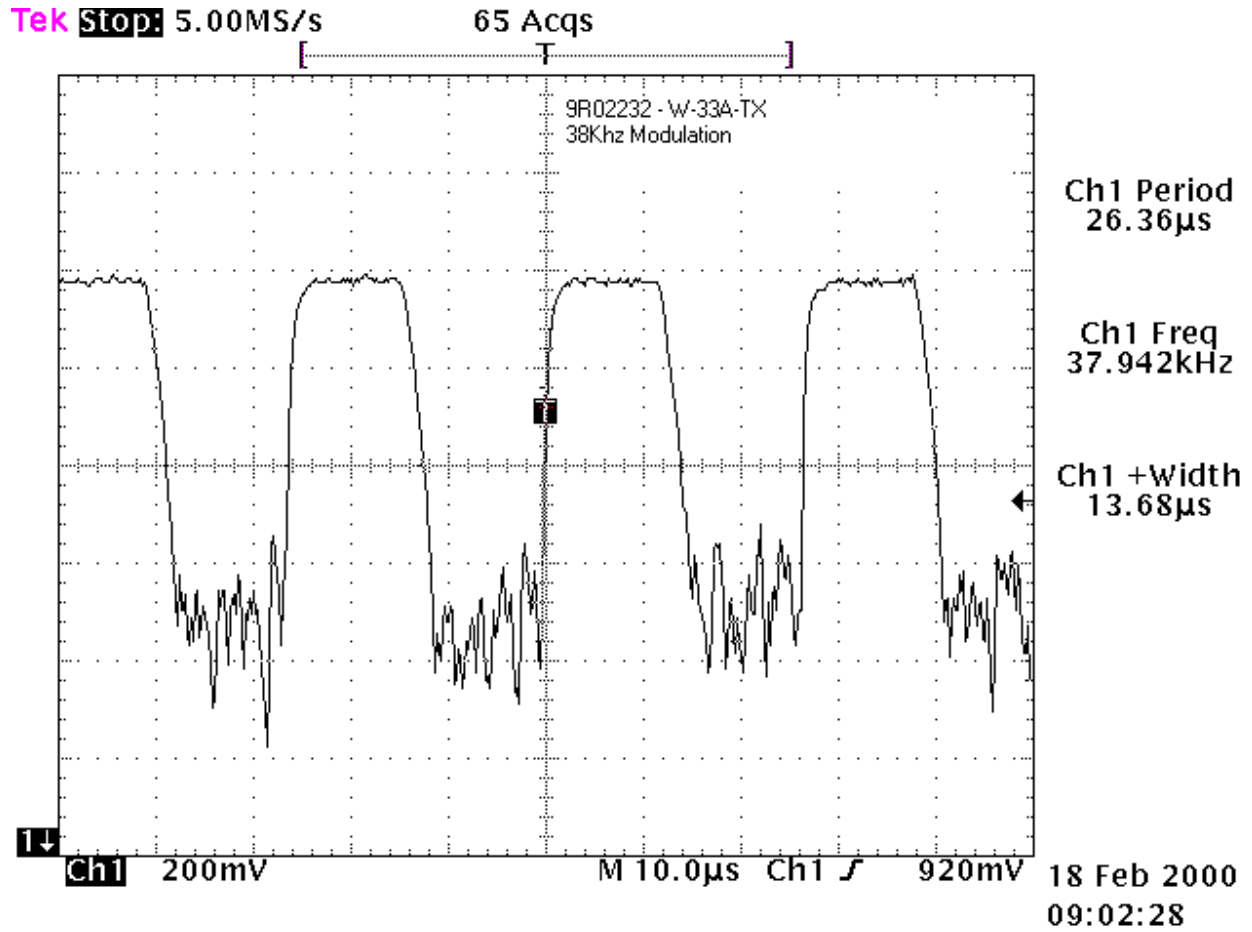

EQUIPMENT: W-33A-TX
FCC ID: BJ4-61WRC33ATX

Section 4. Radiated Emissions

NAME OF TEST: Radiated Emissions	PARA. NO.: 15.231(b)
TESTED BY: Glen Westwell	DATE: February 22, 2000

Minimum Standard:

Permissible Field Strength Limits (Momentarily Operated Devices)

Fundamental Frequency (MHz)	Field Strength of Fundamental Microvolts/Meter at 3 meters; (watts)	Field Strength of Unwanted Emissions Microvolts/Meter at 3 meters; (watts)
40.66 - 40.70	2,250	225
70-130	1, 250	125
130-174	1,250 to 3,750*	125 to 375
174-260 (note 1)	3,750	375
260-470 (note 1)	3,750 to 12,500*	375 to 1,250
Above 470	12,500	1,250

Notes:

# Use quasi-peak or averaging meter.	For 130 - 174 MHz: $FS \text{ (microvolts/m)} = (56.82 \times F) - 6136$
* Linear interpolation with frequency <i>F</i> in MHz	For 260 - 470 MHz: $FS \text{ (microvolts/m)} = (41.67 \times F) - 7083$

Any emissions that fall within the restricted bands of 15.205 shall not exceed the following limits:

Frequency (MHz)	Field Strength (µV/m @ 3m)	Field Strength (dB @ 3m)
30 - 88	100	40.0
88 - 216	150	43.5
216 - 960	200	46.0
Above 960	500	54.0

Test Results: Complies. The worst-case emission level is 65.8 dBµV/m @ 3m at 315.4 MHz. This is 9.8 dB below the specification limit.

Test Data: See attached table.

Above 1 GHz a spectrum analyzer and low noise amplifier are used to measure emission levels. The spectrum analyzer resolution bandwidth was set to 1 MHz and video bandwidth was 3 MHz.

In the case of handheld equipment, the E.U.T. is rotated in three planes to obtain worst-case results.

EQUIPMENT: W-33A-TX
 FCC ID: BJ4-61WRC33ATX

Test Data - Radiated Emissions

Test Distance (meters) : 3		Range: A Tower		Receiver: ESVP / 8565E		RBW: 1 MHz		Detector: PEAK			
Freq. (MHz)	Ant. *	Pol. (V/H)	Ant. HGT. (m)	Table (deg.)	RCVD Signal (dBµV/m)	Ant. Factor (dB)**	Amp. Gain (dB)***	Duty Cycle (dB)	Field Strength (dBµV/m)	Limit (dBµV/m)	Margin (dB)
315.54	L/P	V			45.4	18.5		-6.0	57.9	75.6	17.7
315.54	L/P	H			53.3	18.5		-6.0	65.8	75.6	9.8
630.82	L/P	V			17.3	24.9		-6.0	36.2	55.6	19.4
630.82	L/P	H			22.9	24.9		-6.0	41.8	55.6	13.8
946.9	L/P	V			17.7	30.4		-6.0	42.1	55.6	13.5
946.9	L/P	H			18.1	30.4		-6.0	42.5	55.6	13.1
1261.4	Hrn2	V			16.5	29.2		-6.0	39.7	55.6	15.9
1261.4	Hrn2	H			20.3	29.2		-6.0	43.5	55.6	12.1
1577.7	Hrn2	V			54.5	31.2	-44.5	-6.0	35.2	54.0	18.8
1577.7	Hrn2	H			55.5	31.2	-44.5	-6.0	36.2	54.0	17.8
1894.2	Hrn2	V			56.0	33.1	-47.2	-6.0	35.9	55.6	19.7
1894.2	Hrn2	H			59.8	33.1	-47.2	-6.0	39.7	55.6	15.9
2209.2	Hrn2	V			56.3	34.5	-47.5	-6.0	37.3	55.6	18.3
2209.2	Hrn2	H			49.0	34.5	-47.5	-6.0	30.0	55.6	25.6

Notes:
 B/C = Biconical, B/L = Biconilog, L/P = Log-Periodic, H = Horn, D/P = Dipole
 * Re-measured using dipole antenna.
 ** Includes cable loss when amplifier is not used.
 *** Includes cable loss.
 () Denotes failing emission level.
 All Harmonics up to the 10th were searched.
 Any non-reported harmonics were not detected.
 The noise floor was 20 dBµV below the limit.

EQUIPMENT: W-33A-TX
FCC ID: BJ4-61WRC33ATX

Radiated Photographs (Worst Case Configuration)

Front View



Rear View



EQUIPMENT: W-33A-TX
FCC ID: BJ4-61WRC33ATX

Section 5. Occupied Bandwidth

NAME OF TEST: Occupied Bandwidth	PARA. NO.: 15.231(c)
TESTED BY: Glen Westwell	DATE: February 18, 2000

Minimum Standard: 15.231(c) The bandwidth of the emission shall be no wider than 0.25% of the center frequency for devices operating above 70 MHz and below 900 MHz. For devices operating above 900 MHz, the emission shall be no wider than 0.5% of the center frequency. Bandwidth is determined at the points 20 dB down from the modulated carrier.

Test Results: Complies. See attached graph. The 20 dB bandwidth is 600 kHz. This is 0.2% of the center frequency.

Test Data: See attached graph.

EQUIPMENT: W-33A-TX
FCC ID: BJ4-61WRC33ATX

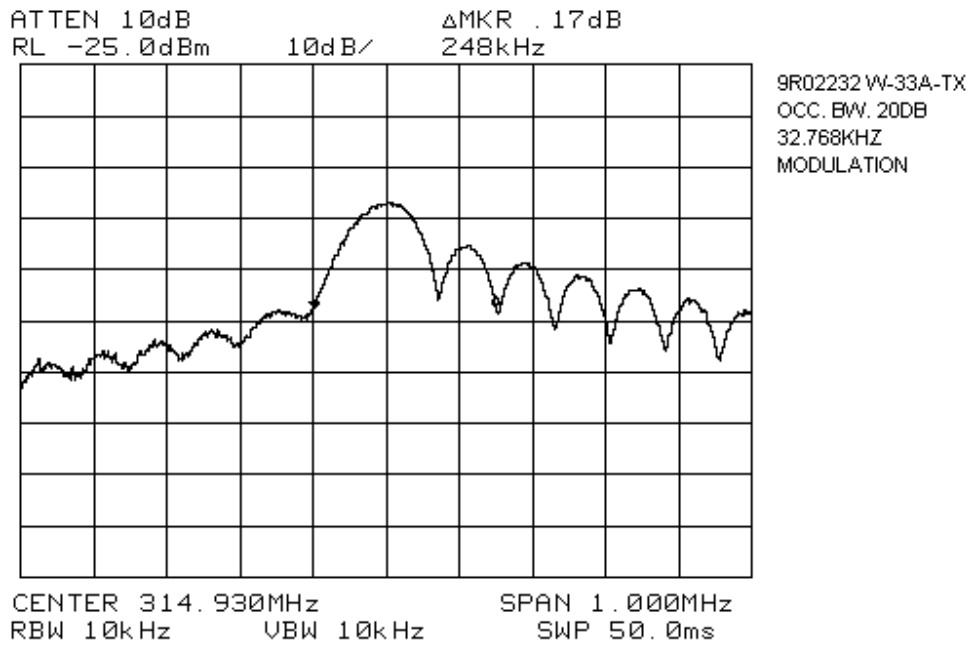

EQUIPMENT: W-33A-TX
FCC ID: BJ4-61WRC33ATX

Section 6. Block Diagrams

Radiated Prescan

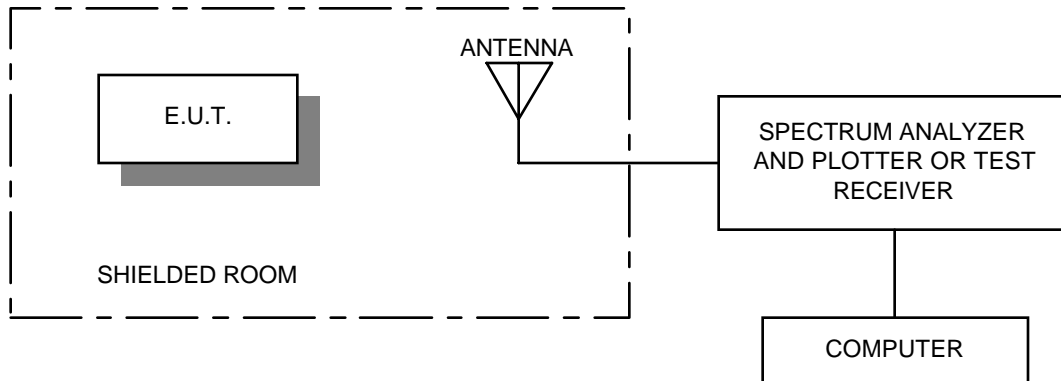

Outdoor Test Site For Radiated Emissions

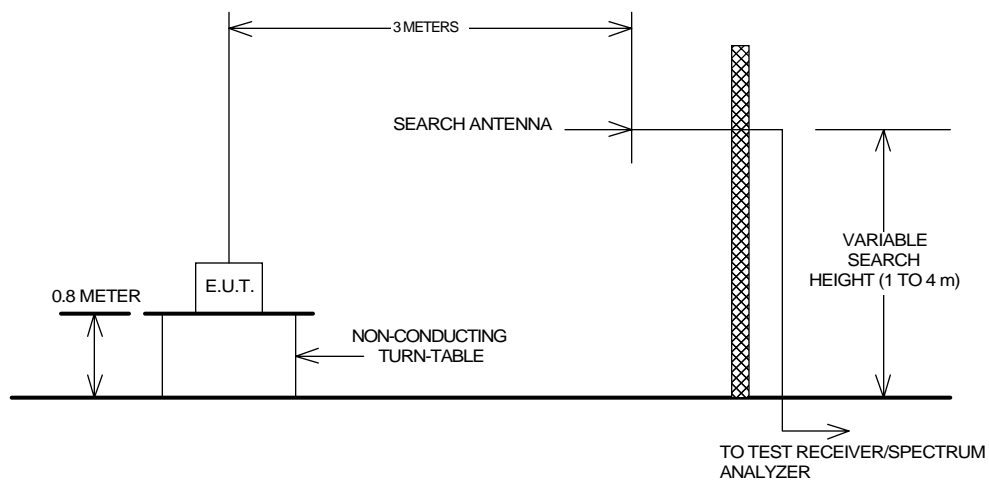

The spectrum was searched up to the 10th harmonic of the fundamental frequency of operation.

EQUIPMENT: W-33A-TX
FCC ID: BJ4-61WRC33ATX

Occupied Bandwidth

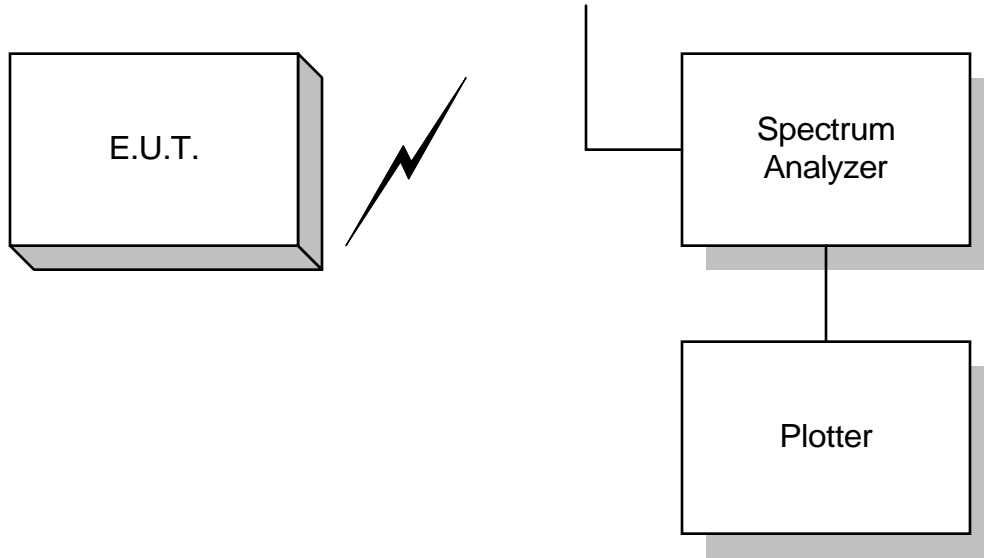

EQUIPMENT: W-33A-TX
FCC ID: BJ4-61WRC33ATX

Section 7. Test Equipment List

CAL CYCLE	EQUIPMENT	MANUFACTURER	MODEL	SERIAL	LAST CAL.	NEXT CAL.
1 Year	Spectrum Analyzer	Hewlett Packard	8565E	FA000981	June 16/99	June 16/00
1 Year	Receiver	Rohde & Schwarz	ESVP	892661/014	Mar. 29/99	Mar. 29/00
2 Year	Horn Antenna	EMCO #2	3115	4336	Nov. 11/99	Nov. 11/00
1 Year	Log Periodic Antenna 2	EMCO	3148	9904-1054	Apr. 30/99	Oct. 30/00
1 Year	Low Noise Amplifier	Avantek	AWT-8035	1005	Sept. 20/99	Sept. 20/00

NA: Not Applicable
NCR: No Cal Required
COU: CAL On Use

KTL Ottawa

FCC PART 15, SUBPART C
FOR LOW POWER TRANSMITTERS
PROJECT NO.: 9R02232
ANNEX A

EQUIPMENT: W-33A-TX
FCC ID: BJ4-61WRC33ATX

ANNEX A
RESTRICTED BANDS

EQUIPMENT: W-33A-TX
FCC ID: BJ4-61WRC33ATX

Section A Restricted Bands of Operation

(a) Except as shown in paragraph (d) of this section , only spurious emissions are permitted in any of the frequency bands listed below:

MHz	MHz	MHz	GHz
0.090 - 0.110	16.42-16.423	399.9-410	4.5-5.15
0.49 - 0.51	16.69475-16.69525	608-614	5.35-5.46
2.1735 - 2.1905	16.80425-16.80475	960-1240	7.25-7.75
3.020 - 3.026	25.5-25.67	1300-1427	8.025-8.5
4.125 - 4.128	37.5-38.25	1435-1626.6	9.0-9.2
4.17725 - 4.17775	73-74.6	1645.5-1646.5	9.3-9.5
4.20725 - 4.20775	74.8-75.2	1660-1710	10.6-12.7
6.215 - 6.218	108-121.94	1718.8-1722.2	13.25-13.4
6.31175 - 6.31225	123-138	2220-2300	14.47-14.5
8.291 - 8.294	149.9-150.05	2310-2390	15.35-16.2
8.362 - 8.366	156.52475-156.52525	2483.5-2500	17.7-21.4
8.37625 - 8.38675	156.7-156.9	2655-2900	22.01-23.12
8.41425 - 8.41475	162.0125-167.17	3260-3267	23.6-24.0
12.29 - 12.293	167.72-173.2	3332-3339	31.2-31.8
12.51975 - 12.52025	240-285	3345.8-3358	36.43-36.5
12.57675 - 12.57725	322-335.4	3600-4400	Above 38.6
13.36 - 13.41			