

KTL Test Report: 0R02235

Applicant: Heath Company, A Division of Desa Int.
PO Box 9004, 2701 Industrial Drive
Bowling Green, KY
42102-9004
USA

**Equipment Under Test:
(E.U.T.)** WB-94A-Tx
Wireless Door Chime

FCC ID: BJ4-61WDB94ATX

In Accordance With: **FCC Part 15, Subpart C**
For Low Power Transmitters Operating Periodically
In The Band 40.66 - 40.77 MHz And Above 70 MHz

Tested By: KTL Ottawa Inc.
3325 River Road, R.R. 5
Ottawa, Ontario K1V 1H2

Authorized By:

K. Carr, Technologist

Date:

Total Number of Pages: 19

EQUIPMENT: WB-94A-Tx Wireless Door Chime
FCC ID: BJ4-61WDB94ATX

Table of Contents

Section 1. Summary of Test Results..... 3

Section 2. Equipment Under Test (E.U.T.) 5

Section 3. Transmission Requirements 9

Section 4. Radiated Emissions..... 11

Section 5. Occupied Bandwidth..... 13

Section 6. Block Diagrams..... 15

Section 7. Test Equipment List 17

Annex A Restricted Bands..... A1

EQUIPMENT: WB-94A-Tx Wireless Door Chime
FCC ID: BJ4-61WDB94ATX

Section 1. Summary of Test Results

General

All measurements are traceable to national standards.

These tests were conducted on a sample of the equipment for the purpose of demonstrating compliance with Part 15, Subpart C, Paragraph 15.231. All tests were conducted using measurement procedure ANSI C63.4-1992. Radiated emissions are made on an open area test site. A description of the test facility is on file with the FCC.



New Submission



Production Unit



Class II Permissive Change



Pre-Production Unit

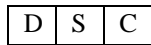

Equipment Code

THIS TEST REPORT RELATES ONLY TO THE ITEM(S) TESTED.

THE FOLLOWING DEVIATIONS FROM, ADDITIONS TO, OR EXCLUSIONS FROM THE TEST SPECIFICATIONS HAVE BEEN MADE.

See " Summary of Test Data".



NVLAP LAB CODE: 100351-0

It is recommended that the margin of compliance be improved to allow for manufacturing tolerances.

TESTED BY: _____ DATE: _____
Russell Grant, Wireless Group Manager

KTL Ottawa Inc. authorizes the above named company to reproduce this report provided it is reproduced in its entirety and for use by the company's employees only.

Any use which a third party makes of this report, or any reliance on or decisions to be made based on it, are the responsibility of such third parties. KTL Ottawa Inc. accepts no responsibility for damages, if any, suffered by any third party as a result of decisions made or actions based on this report.

This report applies only to the items tested.

EQUIPMENT: WB-94A-Tx Wireless Door Chime
FCC ID: BJ4-61WDB94ATX

Summary Of Test Data

Name of Test	Para. Number	Results
Transmission Requirements	15.231(a)	Complies
Radiated Emissions	15.231(b)	Complies
Occupied Bandwidth	15.231(c)	Complies
Frequency Tolerance	15.231(d)	Not Applicable
Periodic Alternate Field Strength Requirements	15.231(e)	Not Applicable
Powerline Conducted Emissions	15.207	Not Applicable

Test Conditions:

Indoor Temperature: 22 °C
 Humidity: 25 %

Outdoor Temperature: 21 °C
 Humidity: 25 %

EQUIPMENT: WB-94A-Tx Wireless Door Chime
FCC ID: BJ4-61WDB94ATX

Section 2. Equipment Under Test (E.U.T.)

General Equipment Information

Manufacturer: Heath Company, A Division of Desa Int.

Model No.: WB-94A-TX

Serial No.: None

Date Received In Laboratory: May 4, 2000

KTL Identification No.: Item #1 & 2

Frequency Range: 315 MHz

Operating Frequency(ies) of Sample: 315 MHz

Type of Emission: Pulse Width Modulation

Emission Designator: 92K0L1D

Supply Power Requirement: Batteries

Duty Cycle Calculation: $20 \text{ Log} \left(\frac{4 \times 13 \times 0.6}{100} \right) = -10.1 \text{ dB}$

EQUIPMENT: WB-94A-Tx Wireless Door Chime
FCC ID: BJ4-61WDB94ATX

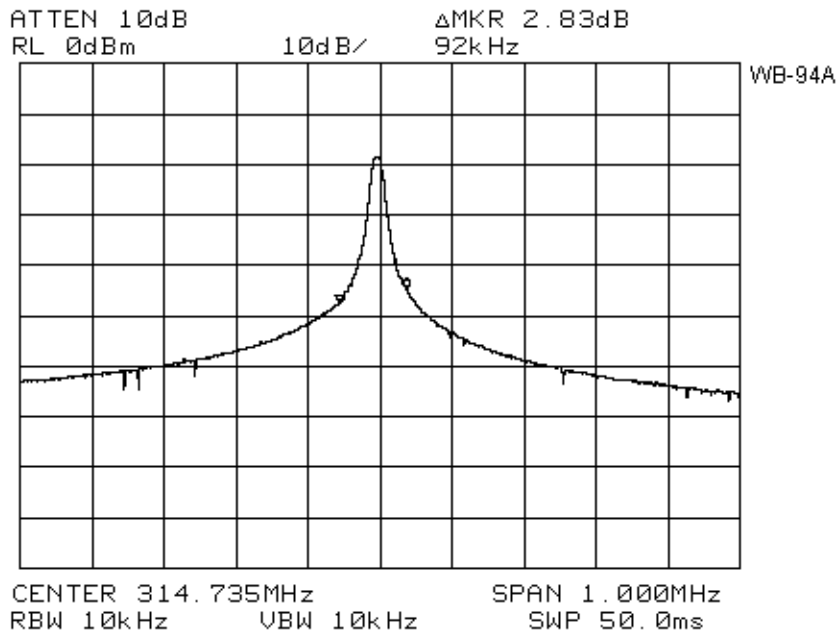

EQUIPMENT: WB-94A-Tx Wireless Door Chime
FCC ID: BJ4-61WDB94ATX

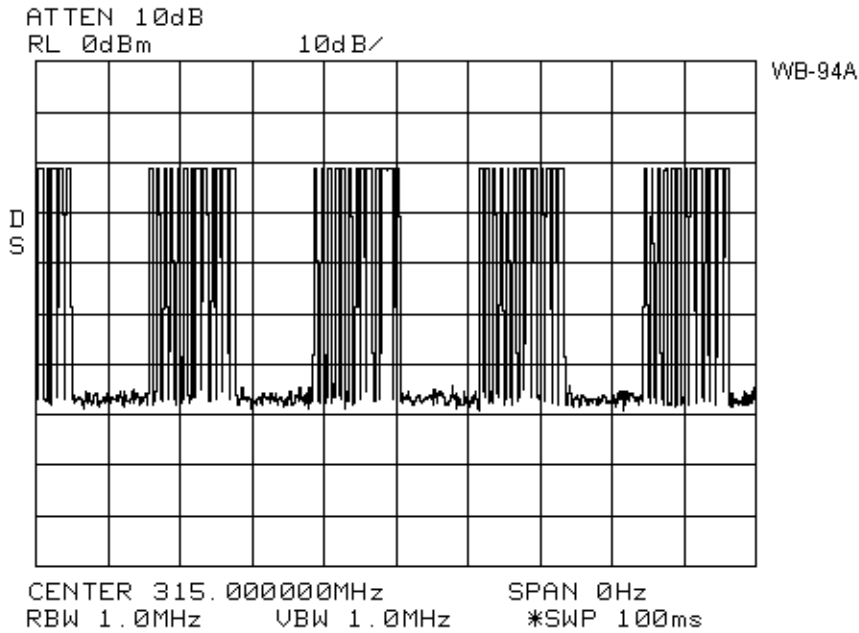

4 Complete Bursts In 100 ms
13 Bits Per Burst
0.6 ms Maximum On Time Per Bit.

Maximum On Time = 4x13x0.6 = 31.2 ms

EQUIPMENT: WB-94A-Tx Wireless Door Chime
FCC ID: BJ4-61WDB94ATX

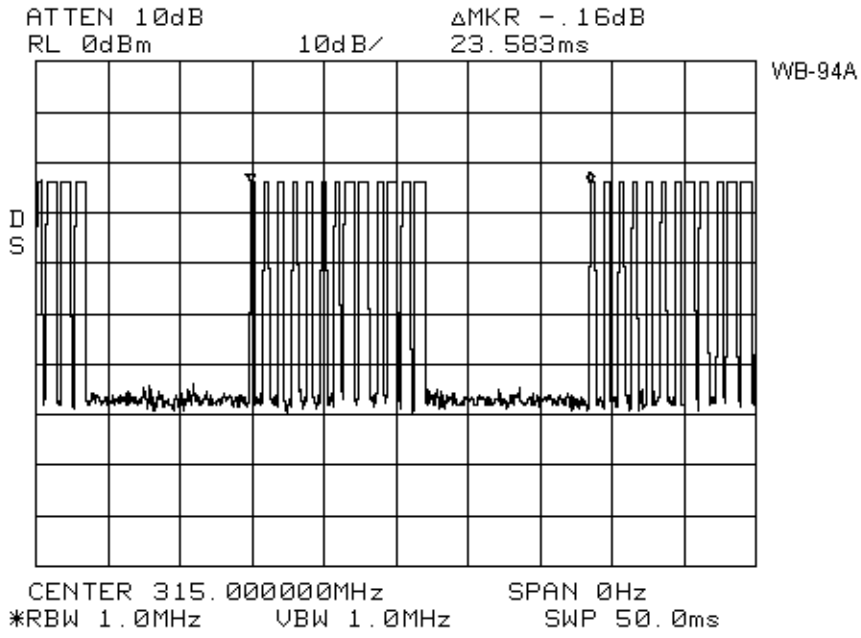

EQUIPMENT: WB-94A-Tx Wireless Door Chime
FCC ID: BJ4-61WDB94ATX

Section 3. Transmission Requirements

Para. No.: 15.231(a)

Test Performed By: Russell Grant	Date of Test: May 5, 2000
---	----------------------------------

Minimum Standard: 15.231(a) Continuous transmissions such as voice, video or data transmissions are not permitted.

15.231(a)(1) A manually operated transmitter shall employ a switch that will automatically deactivate the transmitter within not more than 5 seconds after being released.

15.231(a)(2) A transmitter activated automatically shall cease transmission within 5 seconds of activation.

15.231(a)(3) Periodic transmissions at regular pre-determined intervals are not permitted. However polling or supervisory transmissions to determine system integrity of transmitters used in security or safety applications are allowed if the periodic rate of transmission does not exceed one transmission of not more than one second duration per hour for each transmitter.

15.231(a)(4) Intentional radiators which are employed for radio control purposes during emergencies involving fire, security, and safety of life, when activated to signal an alarm, may operate during the pendency of the alarm.

Test Results: Complies.

Test Data: Compliance was determined by verification of technical specifications and a functional test on the equipment.

EQUIPMENT: WB-94A-Tx Wireless Door Chime
FCC ID: BJ4-61WDB94ATX

Rationale for Compliance with Transmission Requirements

- 15.231(a)(1) :** This equipment has no provision for voice video or data.
- 15.231(a)(2) :** The transmitter is deactivated immediately upon releasing the push button.
- 15.231(a)(3) :** Not applicable
- 15.231(a)(4) :** Not applicable

EQUIPMENT: WB-94A-Tx Wireless Door Chime
 FCC ID: BJ4-61WDB94ATX

Section 4. Radiated Emissions

Para. No.: 15.231(b)

Test Performed By: Russell Grant	Date of Test: May 5, 2000
---	----------------------------------

Minimum Standard:

Permissible Field Strength Limits (Momentarily Operated Devices)

Fundamental Frequency (MHz)	Field Strength of Fundamental Microvolts/Meter at 3 meters; (watts)	Field Strength of Unwanted Emissions Microvolts/Meter at 3 meters; (watts)
40.66 - 40.70	2,250	225
70-130	1, 250	125
130-174	1,250 to 3,750*	125 to 375
174-260 (note 1)	3,750	375
260-470 (note 1)	3,750 to 12,500*	375 to 1,250
Above 470	12,500	1,250

Notes:

# Use quasi-peak or averaging meter.	For 130 - 174 MHz: $FS \text{ (microvolts/m)} = (56.82 \times F) - 6136$
* Linear interpolation with frequency F in MHz	For 260 - 470 MHz: $FS \text{ (microvolts/m)} = (41.67 \times F) - 7083$

Any emissions that fall within the restricted bands of 15.205 shall not exceed the following limits:

Frequency (MHz)	Field Strength ($\mu\text{V/m}$ @ 3m)	Field Strength (dB @ 3m)
30 - 88	100	40.0
88 - 216	150	43.5
216 - 960	200	46.0
Above 960	500	54.0

Test Results: Complies. The worst-case emission level is 73.5 dB $\mu\text{V/m}$ @ 3m at 315 MHz. This is 2.1 dB below the specification limit.

Test Data: See attached table.

Above 1 GHz a spectrum analyzer and low noise amplifier are used to measure emission levels. The spectrum analyzer resolution bandwidth was set to 1 MHz and video bandwidth was 3 MHz.

In the case of handheld equipment, the E.U.T. is rotated in three planes to obtain worst-case results.

EQUIPMENT: WB-94A-Tx Wireless Door Chime
FCC ID: BJ4-61WDB94ATX

Test Data - Radiated Emissions

Test Distance (meters) : 3		Range: A Tower		Receiver: ESVP		RBW(kHz): 120		Detector: Q-Peak	
Freq. (MHz)	Ant. *	Pol. (V/H)	RCVD Signal (dBµV/m)	Ant. Factor (dB)**	Amp. Gain (dB)***	Duty Cycle (dB)	Field Strength (dBµV/m)	Limit (dBµV/m)	Margin (dB)
315.0	E/D3	V	58.6	21.9		-10.1	70.4	75.6	5.2
315.0	E/D3	H	61.7	21.9		-10.1	73.5	75.6	2.1
630.0	E/D4	V	31.6	30.9		-10.1	52.4	55.6	3.2
630.0	E/D4	H	23.1	30.9		-10.1	43.9	55.6	11.7
945.0	E/D4	V	20.4	35.8		-10.1	46.1	55.6	9.5
945.0	E/D4	H	13.2	35.8		-10.1	38.9	55.6	16.7
1260.0	Hrn2	V	33.0	29.2		-10.1	52.1	55.6	3.5
1260.0	Hrn2	H	18.0	29.2		-10.1	37.1	55.6	18.5
1560.0	Hrn2	V	21.3	31.1		-10.1	42.3	54.0	11.7
1560.0	Hrn2	H	11.3	31.1		-10.1	32.3	54.0	21.7
2205.0	Hrn2	V	19.0	34.5		-10.1	43.4	54.0	10.6
2205.0	Hrn2	H	12.7	34.5		-10.1	37.1	54.0	16.9

Notes:
 B/C = Biconical, B/L = Biconilog, L/P = Log-Periodic, H = Horn, D/P = Dipole
 * Re-measured using dipole antenna.
 ** Includes cable loss when amplifier is not used.
 *** Includes cable loss.
 () Denotes failing emission level.
 N.D. = Not Detected

EQUIPMENT: WB-94A-Tx Wireless Door Chime
FCC ID: BJ4-61WDB94ATX

Section 5. Occupied Bandwidth

Para. No.: 15.231(c)

Test Performed By: Russell Grant	Date of Test: May 5, 2000
---	----------------------------------

Minimum Standard: 15.231(c) The bandwidth of the emission shall be no wider than 0.25% of the center frequency for devices operating above 70 MHz and below 900 MHz. For devices operating above 900 MHz, the emission shall be no wider than 0.5% of the center frequency. Bandwidth is determined at the points 20 dB down from the modulated carrier.

Test Results: Complies. See attached graph.

The 20 dB bandwidth is 48 kHz.
This is 0.0152% of the center frequency.

Test Data: See attached graph.

EQUIPMENT: WB-94A-Tx Wireless Door Chime
FCC ID: BJ4-61WDB94ATX

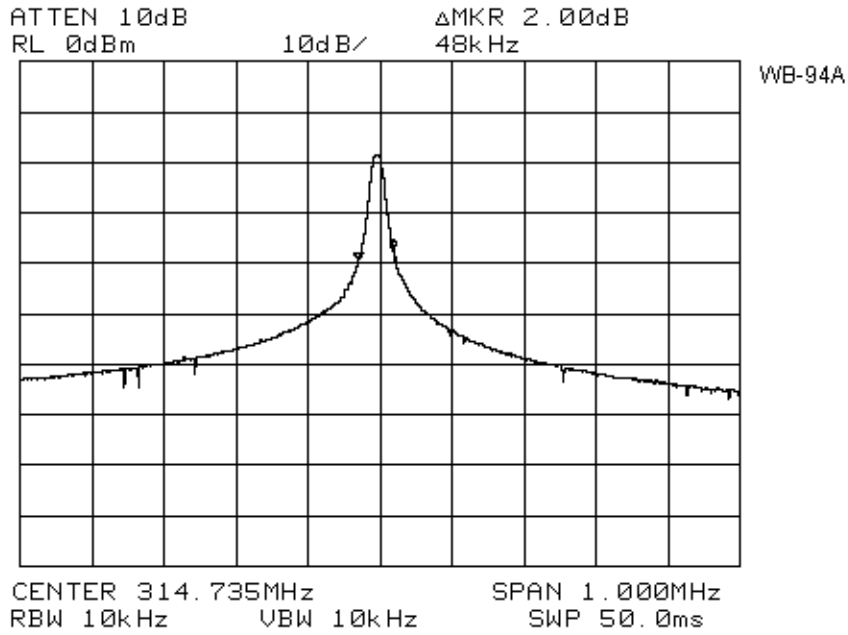

EQUIPMENT: WB-94A-Tx Wireless Door Chime
FCC ID: BJ4-61WDB94ATX

Section 6. Block Diagrams

Radiated Prescan

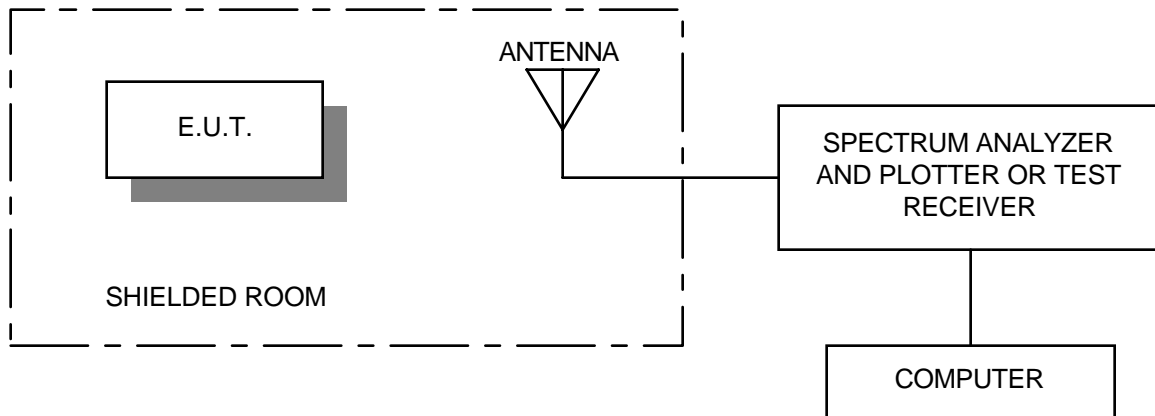

Outdoor Test Site For Radiated Emissions

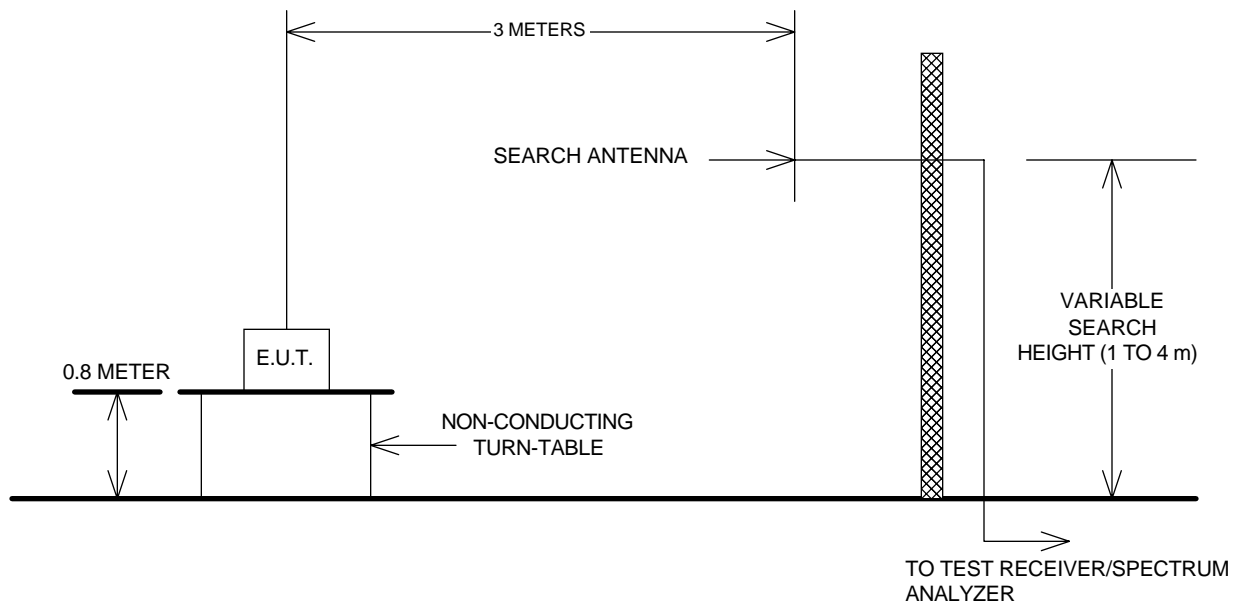

The spectrum was searched up to the 10th harmonic of the fundamental frequency of operation.

EQUIPMENT: WB-94A-Tx Wireless Door Chime
FCC ID: BJ4-61WDB94ATX

Occupied Bandwidth

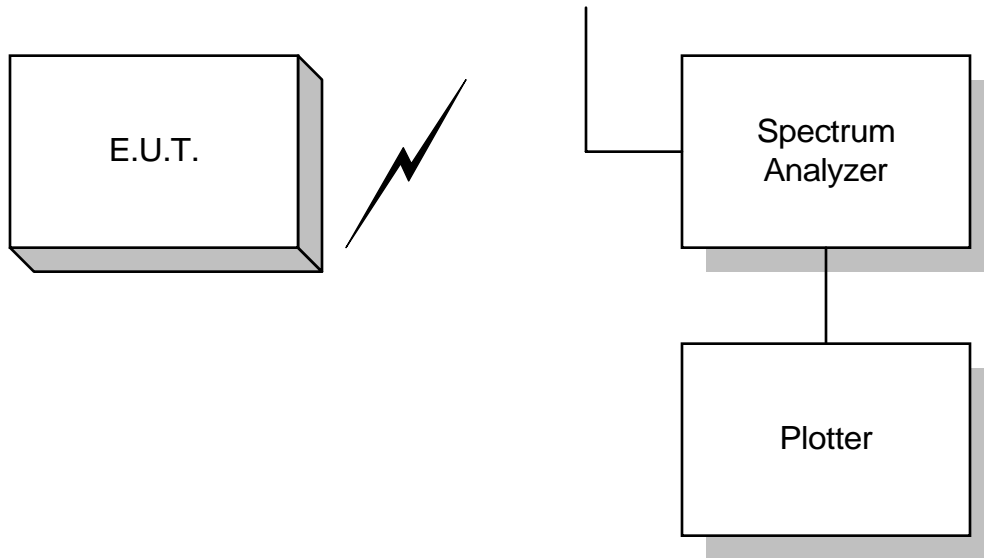

EQUIPMENT: WB-94A-Tx Wireless Door Chime
FCC ID: BJ4-61WDB94ATX

Section 7. Test Equipment List

CAL CYCLE	EQUIPMENT	MANUFACTURER	MODEL	SERIAL	LAST CAL.	NEXT CAL.
1 Year	Spectrum Analyzer	Hewlett Packard	8565E	FA000981	June 16/99	June 16/00
1 Year	Receiver	Rohde & Schwarz	ESVP	892661/014	April 5/00	April 5/01
1 Year	Horn Antenna	EMCO #2	3115	4336	Nov. 11/99	Nov. 11/00
1 Year	Dipole Antenna Set	EMCO #2	3121C	FA001349	June 5/00	June 5/01

NA: Not Applicable
NCR: No Cal Required
COU: CAL On Use

KTL Ottawa

FCC PART 15, SUBPART C
FOR LOW POWER TRANSMITTERS
PROJECT NO.: 0R02235
ANNEX A

EQUIPMENT: WB-94A-Tx Wireless Door Chime
FCC ID: BJ4-61WDB94ATX

Annex A

Restricted Bands

EQUIPMENT: WB-94A-Tx Wireless Door Chime
FCC ID: BJ4-61WDB94ATX

Section A Restricted Bands of Operation

(a) Except as shown in paragraph (d) of this section , only spurious emissions are permitted in any of the frequency bands listed below:

MHz	MHz	MHz	GHz
0.090 - 0.110	16.42-16.423	399.9-410	4.5-5.15
0.49 - 0.51	16.69475-16.69525	608-614	5.35-5.46
2.1735 - 2.1905	16.80425-16.80475	960-1240	7.25-7.75
3.020 - 3.026	25.5-25.67	1300-1427	8.025-8.5
4.125 - 4.128	37.5-38.25	1435-1626.6	9.0-9.2
4.17725 - 4.17775	73-74.6	1645.5-1646.5	9.3-9.5
4.20725 - 4.20775	74.8-75.2	1660-1710	10.6-12.7
6.215 - 6.218	108-121.94	1718.8-1722.2	13.25-13.4
6.31175 - 6.31225	123-138	2220-2300	14.47-14.5
8.291 - 8.294	149.9-150.05	2310-2390	15.35-16.2
8.362 - 8.366	156.52475-156.52525	2483.5-2500	17.7-21.4
8.37625 - 8.38675	156.7-156.9	2655-2900	22.01-23.12
8.41425 - 8.41475	162.0125-167.17	3260-3267	23.6-24.0
12.29 - 12.293	167.72-173.2	3332-3339	31.2-31.8
12.51975 - 12.52025	240-285	3345.8-3358	36.43-36.5
12.57675 - 12.57725	322-335.4	3600-4400	Above 38.6
13.36 - 13.41			