

# **Exhibit C**

# **Measurement Rerort**

**Heath Company**

**FCC ID.:BJ4-53WOS22ARX**

**Indoor Lamp Module Receiver**

***FCC Part 15 Subpart B***  
***EMI TEST REPORT***

of

E.U.T. : Indoor Lamp Module Receiver

FCC ID. : BJ4-53WOS22ARX

MODEL : SL-5322-A

Receiving Frequency : 315 MHz

for

APPLICANT : Heath Comapny

ADDRESS : 455 Riverview Drive, Benton Harbor,  
MI 49022, U.S.A.

Test Performed by

**ELECTRONICS TESTING CENTER, TAIWAN**

NO. 8 LANE 29, WENMIMG ROAD,  
LOSHAN TSUN, KWEISHAN HSIANG,  
TAOYUAN, TAIWAN, R.O.C.

Tel:(03)3280026-32

Fax:(03)3280034

Report Number : ET87R-03-015-02

# TEST REPORT CERTIFICATION

Applicant : Heath Comapny  
 455 Riverview Drive, Benton Harbor, MI 49022, U.S.A.

Manufacturer : Interquartz (M) Berhad. Ltd.  
 Plot 149, Bayan Lepas, Free Trade Zone, Phase 1, 11900 Penang,  
 Malaysia

Description of EUT :

- a) Type of EUT : Indoor Lamp Module Receiver
- b) Trade Name : Heath Zenith
- c) Model No. : SL-5322-A
- d) Receiver Type : Super-regeneration
- e) FCC ID : BJ4-53WOS22ARX
- f) Receiving Frequency : 315 MHz
- g) Power Supply : AC 120V, 60Hz

Regulation Applied : FCC Rules and Regulations Part 15 Subpart B (1996)

I HEREBY CERTIFY THAT; The data shown in this report were made in accordance with the procedures given in ANSI C63.4 and the energy emitted by the device was founded to be within the limits applicable. I assume full responsibility for accuracy and completeness of these data.

Issued Date :           JUL. 06, 1998          

Test Engineer :           Tien Lu Liao            
 ( Tien Lu Liao )

Approve & Authorized Signer :           Will Yauo            
 Will Yauo, Supervisor  
 EMI Test Site of ELECTRONICS  
 TESTING CENTER, TAIWAN

# Table of Contents

# Page

<b>1. GENERAL INFORMATION.....</b>	<b>1</b>
1.1 PRODUCT DESCRIPTION.....	1
1.2 CHARACTERISTICS OF DEVICE.....	1
1.3 TEST METHODOLOGY.....	1
1.4 TEST FACILITY.....	1
<b>2. DEFINITION AND LIMITS.....</b>	<b>2</b>
2.1 DEFINITION.....	2
2.2 LIMITATION.....	2
2.3 LABELING REQUIREMENT.....	3
2.4 USER INFORMATION.....	3
<b>3. RADIATED EMISSION MEASUREMENT.....</b>	<b>4</b>
3.1 APPLICABLE STANDARD.....	4
3.2 MEASUREMENT PROCEDURE.....	4
3.3 RADIATED EMISSION DATA.....	6
3.4 FIELD STRENGTH CALCULATION.....	8
3.5 RADIATED EMISSION MEASURING EQUIPMENT.....	8
3.6 RADIATED MEASUREMENT PHOTOS.....	9
<b>4. CONDUCTED EMISSION MEASUREMENT.....</b>	<b>10</b>
4.1 STANDARD APPLICABLE.....	10
4.2 MEASUREMENT PROCEDURE.....	10
4.3 CONDUCTED EMISSION DATA.....	11
4.4 RESULT DATA CALCULATION.....	16
4.5 CONDUCTED EMISSION MEASURING EQUIPMENT.....	16
4.6 CONDUCTED EMISSION MEASURING PHOTOS.....	17

## 1. GENERAL INFORMATION

### 1.1 Product Description

- a) Type of EUT : Indoor Lamp Module Receiver
- b) Trade Name : Heath Zenith
- c) Model No. : SL-5322-A
- d) Type of Receiver : Super-regeneration
- e) FCC ID : BJ4-53WOS22ARX
- f) Receiving Frequency : 315 MHz
- g) Power Supply : AC 120V, 60Hz

### 1.2 Characteristics of Device

- Features:
1. Turns on lighting when motion is detected.
  2. Automatically turns lighting off.
  3. Photocell keeps the lighting off during daylight hours.
  4. LED indicates motion was sensed (day or night).
  5. Turns indoor lights on when motion is detected.
  6. Sounds chime indoors when motion is detected outdoors.

- Requirements:
1. The Light Control requires 12-volts AC.
  2. If you want use Manual Mode, the control must be wired through a switch.
  3. Some codes require installation by a qualified electrician.
  4. This product is intended for use with the enclosed gasket and with a junction box marked for use in wet locations.

### 1.3 Test Methodology

Both conducted and radiated testing were performed according to the procedures in section 12.1 of ANSI C63.4(1992).

For detail procedures, please see each measuring item.

### 1.4 Test Facility

The open area test site and conducted measurement facility used to collect the radiated data is located on the roof top of Building at No.34, 5 Lirn, Din Fu Tsun, Lin Kou, Taipei, Taiwan, R.O.C.

This site has been fully described in a report submitted to your office, and accepted in a letter dated Feb. 10 , 1997.

## 2. DEFINITION AND LIMITS

### 2.1 Definition

Unintentional radiator:

A device that intentionally generates and radio frequency energy for use within the device, or that sends radio frequency signals by conduction to associated equipment via connecting wiring, but which is not intended to emit RF energy by radiation or induction.

### 2.2 Limitation

#### (1) Conducted Emission Limits :

According to 15.107 , Except for Class A digital devices, for equipment that is designed to be connected to the public utility (AC) power line, the radio frequency voltage that is conducted back onto the AC power line on any frequency or frequencies within the band 450 kHz to 30 MHz shall not exceed 250 microvolts. Compliance with this provision shall be based on the measurement of the radio frequency voltage between each power line and ground at the power terminals.

#### Class B Line Conducted Emission Limits :

Frequency MHz	Emissions $\mu V$	Emissions dB $\mu V$
0.45 - 30.0	250	48.0

#### (2) Radiated Emission Limits :

According to 15.109 ,Except for Class A digital devices, the field strength of radiated emissions from unintentional radiators at a distance of 3 meters shall not exceed the following values:

#### Class B Radiated Emission Limits :

Frequency MHz	Distance Meters	Radiated dB $\mu V/m$	Radiated $\mu V/m$
30 - 88	3	40.0	100
88 - 216	3	43.5	150
216 - 960	3	46.0	200
above 960	3	54.0	500

### **2.3 Labeling Requirement**

The device shall bear the following statement in a conspicuous location on the device :

This device complies with part 15 of the FCC Rules. Operation is subject to the following two conditions : (1) This device may not cause harmful interference, and (2) this device must accept any interference received, including interference that may cause undesired operation.

### **2.4 User Information**

The users manual or instruction manual for an intentional or unintentional radiator shall caution the user that changes or modifications not expressly approved by the party responsible for compliance could void the user's authority to operate the equipment.

### 3. RADIATED EMISSION MEASUREMENT

#### 3.1 Applicable Standard

For unintentional radiator, the radiated emission shall comply with § 15.109(a).

#### 3.2 Measurement Procedure

1. Setup the configuration per figure 1 and 2 for frequencies measured below and above 1 GHz respectively.
2. For emission frequencies measured below 1 GHz, a pre-scan is performed in a shielded chamber to determine the accurate frequencies of higher emissions will be checked on a open test site. As the same purpose, for emission frequencies measured above 1 GHz, a pre-scan also be performed with a 1 meter measuring distance before final test. For super-regeneration receiver, there is tow mode of measurement, one is stand-by without a TX signal (CW), and the other is receiving a proper TX signal.
3. For emission frequencies measured below and above 1 GHz, set the spectrum analyzer on a 100 kHz and 1 MHz resolution bandwidth respectively for each frequency measured in step 2.
4. The search antenna is to be raised and lowered over a range from 1 to 4 meters in horizontally polarized orientation. Position the highness when the highest value is indicated on spectrum analyzer, then change the orientation of EUT on test table over a range from 0 ° to 360 ° with a speed as slow as possible, and keep the azimuth that highest emission is indicated on the spectrum analyzer. Vary the antenna position again and record the highest value as a final reading. A RF test receiver is also used to confirm emissions measured.
5. Repeat step 4 until all frequencies need to be measured were complete.
6. Repeat step 5 with search antenna in vertical polarized orientations.
7. Check the three frequencies of highest emission with varying the placement of cables associated with EUT to obtain the worse case and record the result.



Figure 1 : Frequencies measured below 1 GHz configuration

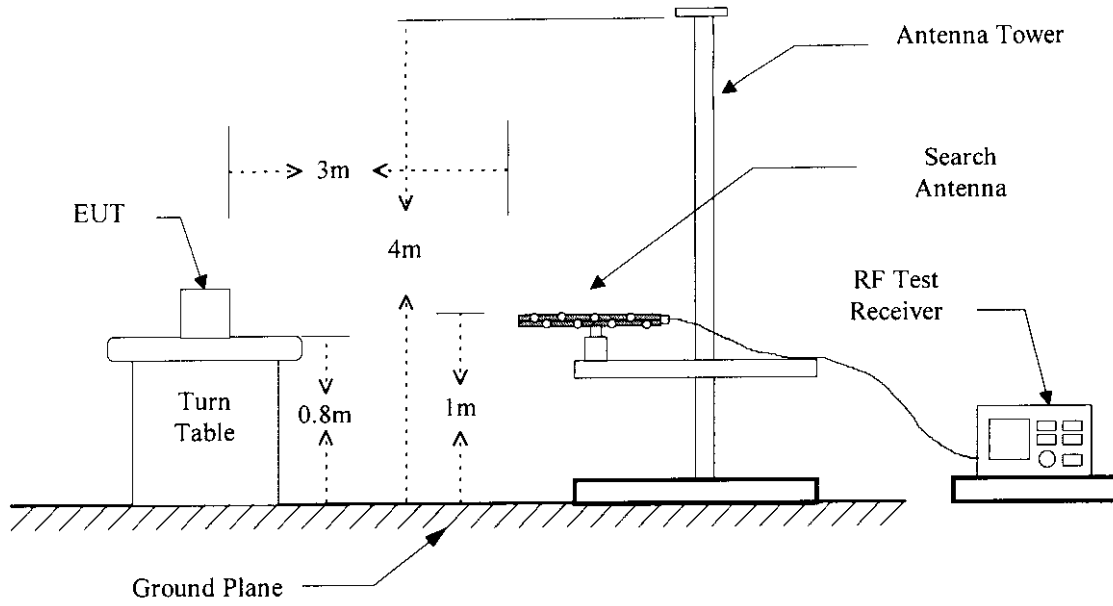
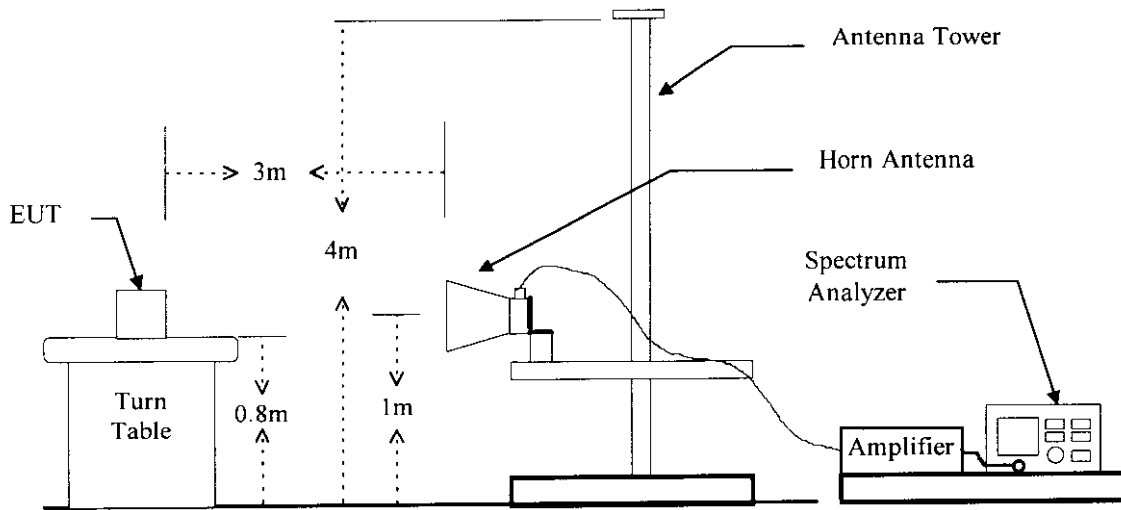

Figure 2 : Frequencies measured above 1 GHz configuration



**3.3 Radiated Emission Data****a. TX Off**

Operation Mode : Load: 500W (manual)

Test Date : JUN. 25, 1998

Temperature : 26 °C

Humidity : 58%

Frequency (MHz)	Ant-Pol H/V	Meter Reading (dBuV)	Corrected Factor (dB)	Result @3m (dBuV/m)	Limit @3m (dBuV/m)	Margin (dB)	Table Degree (Deg.)	Ant. High (m)
299.090	H	40.0	-0.9	39.1	46.0	-6.9	90	1.30
314.490	H	49.4	-6.8	42.6	46.0	-3.4	90	1.30
600.000	H	33.6	-4.5	29.1	46.0	-16.9	27	1.20
628.000	H	32.4	-3.3	29.1	46.0	-16.9	27	1.20
899.340	H	32.4	2.1	34.5	46.0	-11.5	0	1.10
943.470	H	31.0	3.1	34.1	46.0	-11.9	0	1.10
1196.360	H/V	---	-8.8	---	54.0	---	---	---
1257.960	H/V	---	-8.6	---	54.0	---	---	---
1495.450	H/V	---	-7.5	---	54.0	---	---	---
1572.450	H/V	---	-7.1	---	54.0	---	---	---
1497.540	H/V	---	-7.5	---	54.0	---	---	---
1886.940	H/V	---	-5.3	---	54.0	---	---	---
2093.630	H/V	---	-4.2	---	54.0	---	---	---
2201.430	H/V	---	-3.8	---	54.0	---	---	---
2392.720	H/V	---	-3.1	---	54.0	---	---	---
2515.920	H/V	---	-2.7	---	54.0	---	---	---
2691.810	H/V	---	-2.1	---	54.0	---	---	---
2830.410	H/V	---	-1.7	---	54.0	---	---	---
2990.900	H/V	---	-1.2	---	54.0	---	---	---
3144.900	H/V	---	-0.9	---	54.0	---	---	---

**Remark** “---” means that the emission level is too low to be measured.

**b. TX On**

Operation Mode : Load: 500W (auto)

Test Date : JUN. 25, 1998

Temperature : 26 °C

Humidity : 58%

Frequency (MHz)	Ant-Pol H/V	Meter Reading (dBuV)	Corrected Factor (dB)	Result @3m (dBuV/m)	Limit @3m (dBuV/m)	Margin (dB)	Table Degree (Deg.)	Ant. High (m)
299.090	H	42.6	-0.9	41.7	46.0	-4.3	90	1.30
314.490	H	50.2	-6.8	43.4	46.0	-2.6	90	1.30
600.000	H	35.5	-4.5	31.0	46.0	-15.0	27	1.20
628.000	H	34.5	-3.3	31.2	46.0	-14.8	27	1.20
899.340	H	33.7	2.1	35.8	46.0	-10.2	0	1.10
943.470	H	33.5	3.1	36.6	46.0	-9.4	0	1.10
1196.360	H/V	---	-8.8	---	54.0	---	---	---
1257.960	H/V	---	-8.6	---	54.0	---	---	---
1495.450	H/V	---	-7.5	---	54.0	---	---	---
1572.450	H/V	---	-7.1	---	54.0	---	---	---
1497.540	H/V	---	-7.5	---	54.0	---	---	---
1886.940	H/V	---	-5.3	---	54.0	---	---	---
2093.630	H/V	---	-4.2	---	54.0	---	---	---
2201.430	H/V	---	-3.8	---	54.0	---	---	---
2392.720	H/V	---	-3.1	---	54.0	---	---	---
2515.920	H/V	---	-2.7	---	54.0	---	---	---
2691.810	H/V	---	-2.1	---	54.0	---	---	---
2830.410	H/V	---	-1.7	---	54.0	---	---	---
2990.900	H/V	---	-1.2	---	54.0	---	---	---
3144.900	H/V	---	-0.9	---	54.0	---	---	---

**Remark** “---” means that the emission level is too low to be measured.

### 3.4 Field Strength Calculation

The field strength is calculated by adding the Antenna Factor and Cable Factor, and subtracting the Amplifier Gain (if any) from the measured reading. The basic equation with a sample calculation is as follows:

$$\text{RESULT} = \text{READING} + \text{CORR. FACTOR}$$

where CORR. FACTOR = Antenna FACTOR + Cable FACTOR

Assume a receiver reading of 22.5 dB  $\mu$  V is obtained. The Antenna Factor of 14.5 and a Cable Factor of 1.5 is added . The total of field strength is 38.5 dB  $\mu$  V/m.

$$\text{RESULT} = 22.5 + 14.5 + 1.5 = 38.5 \text{ dB } \mu \text{ V/m}$$

$$\begin{aligned} \text{Level in } \mu \text{ V/m} &= \text{Common Antilogarithm}[(38.5 \text{ dB } \mu \text{ V/m})/20] \\ &= 84.14 \mu \text{ V/m} \end{aligned}$$

### 3.5 Radiated Emission Measuring Equipment

The following test equipment are used during the radiated test .

Equipment	Manufacturer	Model No.	Next Cal. Date
Spectrum Analyzer	Hewlett-Packard	8568B	10/16/1998
Pre-selector	Hewlett-Packard	85685A	10/16/1998
Quasi Peak Detector	Hewlett-Packard	85650A	10/07/1998
Spectrum Analyzer	Adventest	R3271	09/02/1998
RF Test Receiver	Rohde & Schwarz	ESVS 30	12/19/1998
Horn Antenna	EMCO	3115	08/05/1998
Log periodic Antenna	EMCO	3146	12/10/1999
Biconical Antenna	EMCO	3110	08/05/1998
Preamplifier	Hewlett-Packard	8449B	05/08/1999
Preamplifier	Hewlett-Packard	8447D	12/23/1998

## 4. CONDUCTED EMISSION MEASUREMENT

### 4.1 Standard Applicable

For unintentional and intentional device, Line Conducted Emission Limits are in accordance to § 15.107(a) and § 15.207(a) respectively. Both Limits are identical specification.

### 4.2 Measurement Procedure

1. Setup the configuration per figure 3.
2. A preliminary scan with a spectrum monitor is performed to identify the frequency of emission that has the highest amplitude relative to the limit by operating the EUT in selected modes of operation, typical cable positions, and with a typical system configuration.
3. Record the 6 or 8 highest emissions relative to the limit.
4. Measure each frequency obtained from step 3 by a test receiver set on quasi peak detector function, and then record the accuracy frequency and emission level. If all emissions measured in the specified band are attenuated more than 20 dB from the limit, this step would be ignored, and the peak detector function would be used.
5. Confirm the highest three emissions with variation of the EUT cable configuration and record the final data.
6. Repeat all above procedures on measuring each operation mode of EUT.

Figure 3 : Conducted emissions measurement configuration

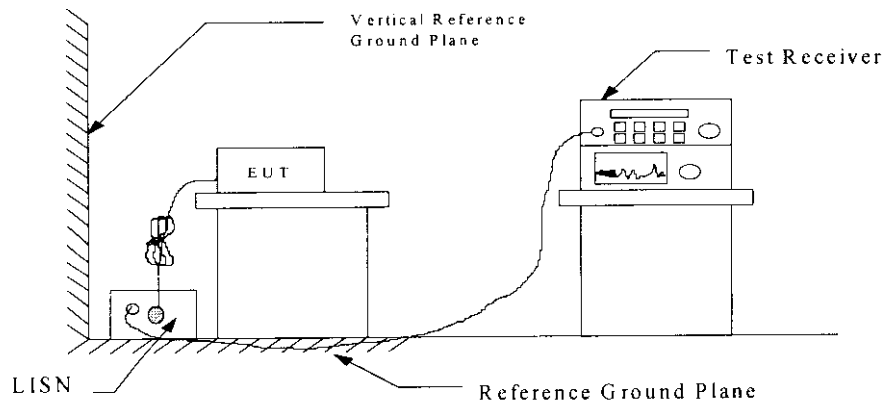

**4.3 Conducted Emission Data****A.**

Operation Mode : Load: 500W (manual) (Tx Off)

Test Date : JUN. 25, 1998 Temperature : 25 °C Humidity: 50%

Frequency (MHz)	Reading (dBuV)		Factor (dB)	Result (dBuV)		Limit (dBuV)	Margin (dB)
	Va	Vb		Va	Vb		
0.639	27.2	26.2	0.2	27.4	26.4	48.0	-20.6
0.954	29.8	27.8	0.3	30.1	28.1	48.0	-17.9
1.268	28.0	26.4	0.3	28.3	26.7	48.0	-19.7
1.903	28.4	27.0	0.3	28.7	27.3	48.0	-19.3
4.288	25.8	27.6	0.3	26.1	27.9	48.0	-20.1
8.554	24.8	29.6	0.5	25.3	30.1	48.0	-17.9
28.901	26.2	27.2	1.1	27.3	28.3	48.0	-19.7

**B.**

Operation Mode : Load: 500 (auto) (Tx On)

Test Date : JUN. 25, 1998 Temperature : 25 °C Humidity: 50%

Frequency (MHz)	Reading (dBuV)		Factor (dB)	Result (dBuV)		Limit (dBuV)	Margin (dB)
	Va	Vb		Va	Vb		
0.642	28.0	26.4	0.2	28.2	26.6	48.0	-19.8
0.741	29.0	21.6	0.3	29.3	21.9	48.0	-18.7
0.958	28.4	27.2	0.3	28.7	27.5	48.0	-19.3
1.113	30.0	26.2	0.3	30.3	26.5	48.0	-17.7
1.564	30.4	24.6	0.3	30.7	24.9	48.0	-17.3
2.337	30.8	26.0	0.3	31.1	26.3	48.0	-16.9

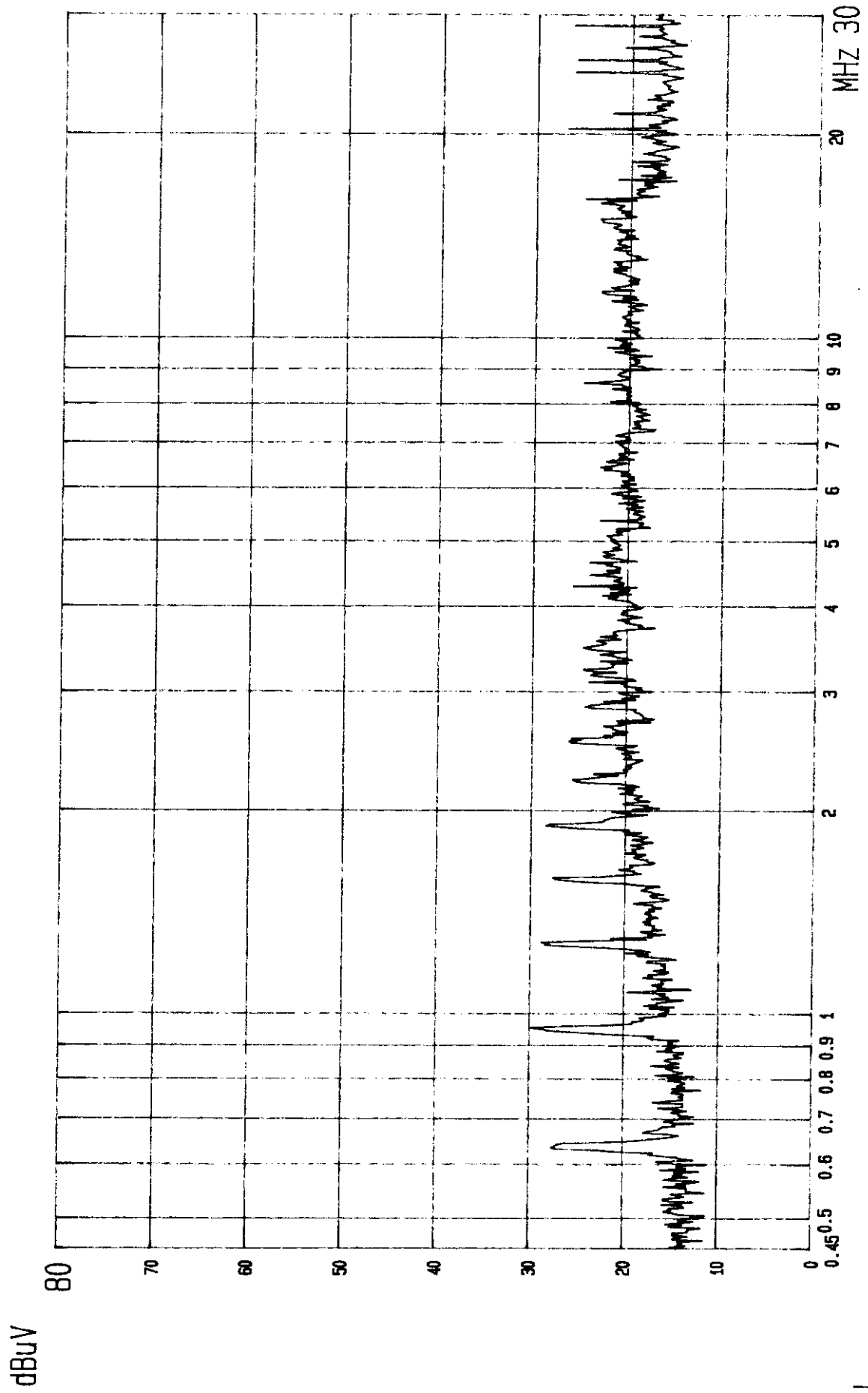

FCC CONDUCTED TEST  
 MODEL: SL-5322-A  
 EUT: RECEIVER  
 MODE: TX OFF/LOAD: 500W LISN: Va  
 POWER: 120V/60HZ  
 8: QP., CLASS B LIMIT  
 ETC EMI LAB.

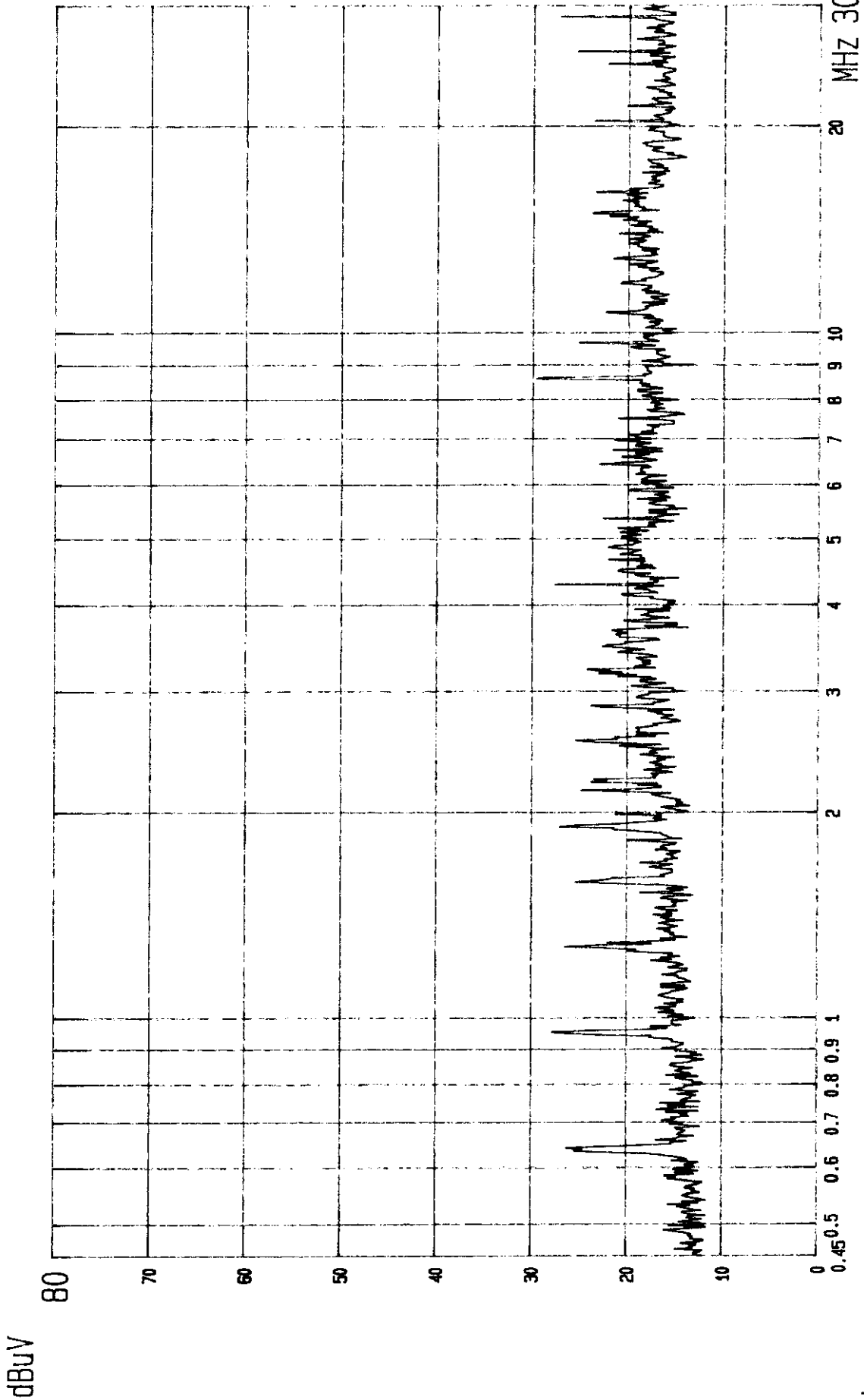

FCC CONDUCTED TEST  
MODEL: SL-5322-A  
EUT: RECEIVER  
MODE: TX OFF/LOAD: 500W  
POWER: 120V/60HZ  
LISN: Vb  
8: QP., CLASS B LIMIT  
ETC EMI LAB.



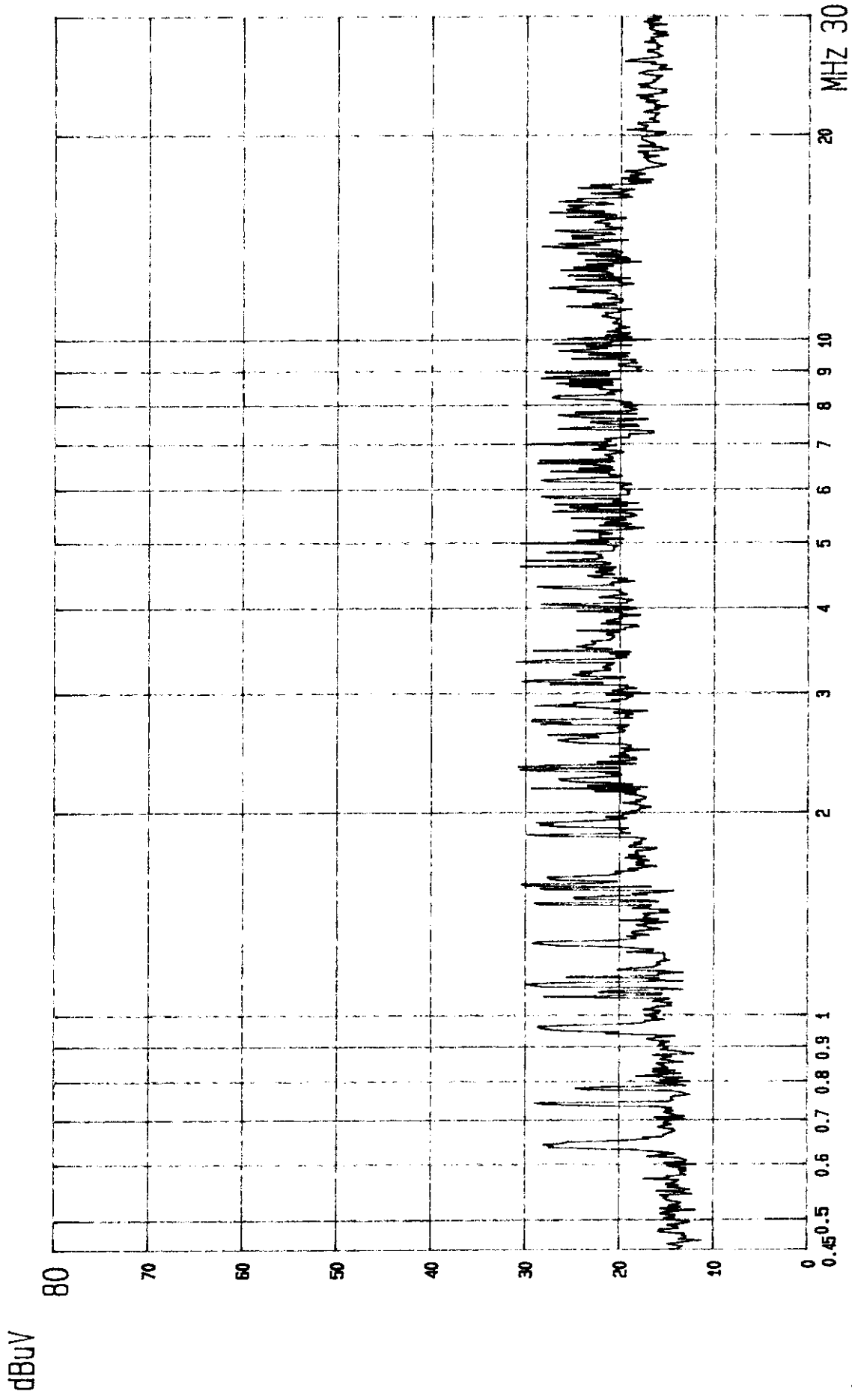

FCC CONDUCTED TEST  
MODEL: SL-5322-A  
EUT: RECEIVER  
MODE: TX ON  
POWER: 120V/60HZ  
LISN: Va  
8: QP., CLASS B LIMIT  
ETC EMI LAB.

dBuV

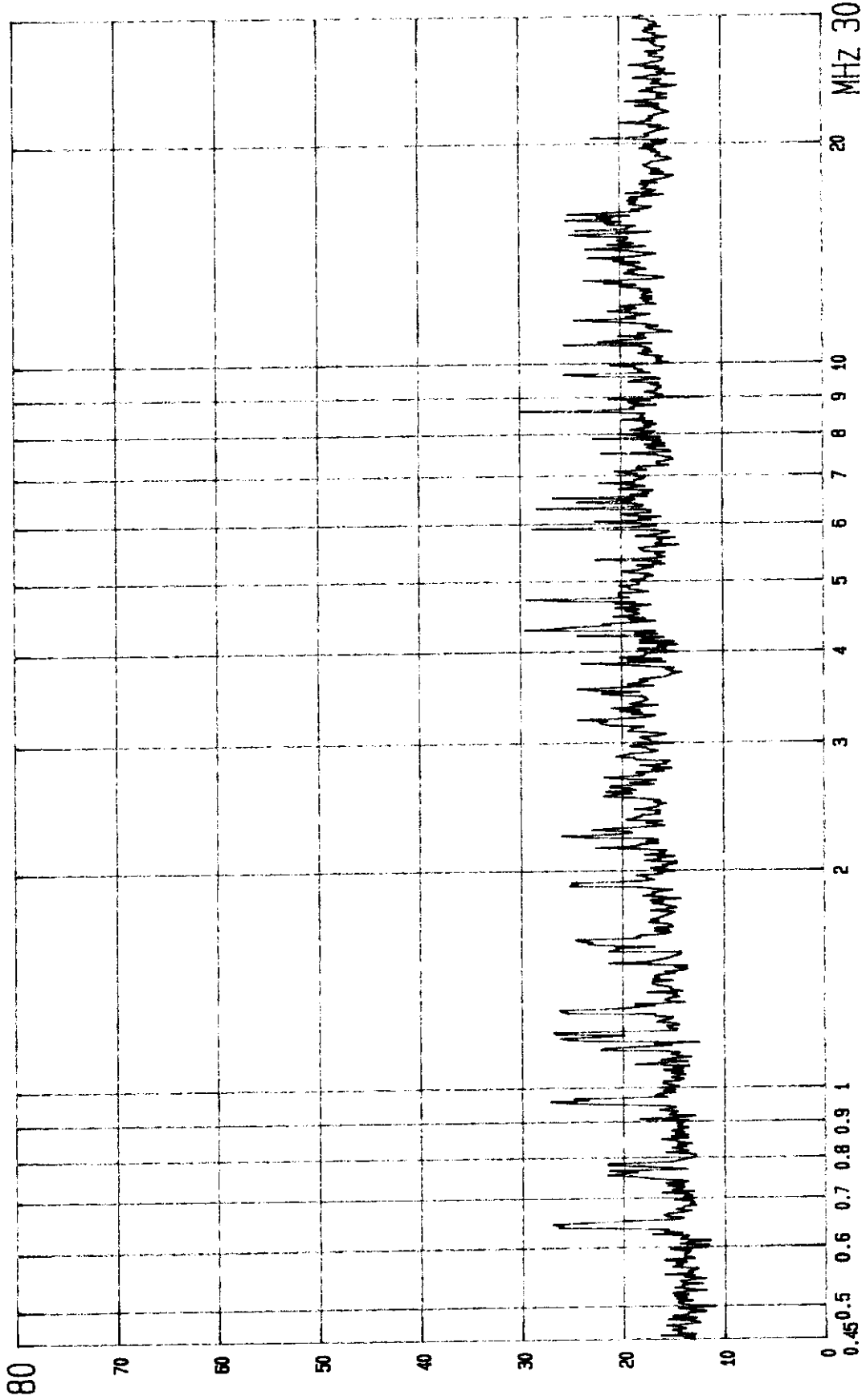

-----  
FCC CONDUCTED TEST      EUT: RECEIVER      POWER: 120V/60HZ      8: 0P., CLASS B LIMIT  
MODEL: SL-5322-A      MODE: TX ON      LISN: Vb      ETC EMI LAB.

#### 4.4 Result Data Calculation

The result data is calculated by adding the LISN Factor to the measured reading. The basic equation with a sample calculation is as follows:

$$\mathbf{RESULT = READING + LISN FACTOR}$$

Assume a receiver reading of 22.5 dB  $\mu$  V is obtained, and LISN Factor is 0.1 dB, then the total of field strength is 22.6 dB  $\mu$  V.

$$\text{RESULT} = 22.5 + 0.1 = 22.6 \text{ dB } \mu \text{ V}$$

$$\begin{aligned} \text{Level in } \mu \text{ V} &= \text{Common Antilogarithm}[(22.6 \text{ dB } \mu \text{ V})/20] \\ &= 13.48 \mu \text{ V} \end{aligned}$$

#### 4.5 Conducted Emission Measuring Equipment

The following test equipment are used during the conducted test .

Equipment	Manufacturer	Model No.	Next Cal. Date
RF Test Receiver	Rohde and Schwarz	ESH3	01/04/1999
Spectrum Monitor	Rohde and Schwarz	EZM	N.C.R.
Line Impedance Stabilization network	Kyoritsu	KNW-407	12/01/1998
Plotter	Hewlett-Packard	7440A	N/A
Shielded Room	Riken	N/A	N.C.R.