

FCC Part 15 Subpart C
EMI TEST REPORT
of

E.U.T. : Outdoor Motion Sensing Light
Control Transmitter

FCC ID. : BJ4-53PIR25ATX

MODEL : SL-5325-A

Working Frequency : 315 MHz

for

APPLICANT : Heath Company

ADDRESS : 455, Riverview Drive, Benton Harbor,
MI 49022, U.S.A.

Test Performed by

ELECTRONICS TESTING CENTER, TAIWAN
NO. 8 LANE 29, WENMING ROAD,
LOSHAN TSUN, KWEISHAN HSIANG,
TAOYUAN, TAIWAN, R.O.C.

Tel:(03)3280026-32

Fax:(03)3280034

Report Number : ET87R-03-015-01

TEST REPORT CERTIFICATION

Applicant : Heath Company
455 Riverview Drive, Benton Harbor, MI 49022, U.S.A.

Manufacturer : Interquartz (M) Berhad. Ltd.
Plot 149, Bayan Lepas, Free Trade Zone, Phase 1, 11900 Penang,
Malaysia

Description of EUT :

- a) Type of EUT : Outdoor Motion Sensing Light Control Transmitter
- b) Trade Name : Heath Zenith
- c) Model No. : SL-5325-A
- d) FCC ID : BJ4-53PIR25ATX
- e) Working Frequency : 315 MHz
- f) Power Supply : AC 120V, 60Hz

Regulation Applied : FCC Rules and Regulations Part 15 Subpart C (1996)

I HEREBY CERTIFY THAT; The data shown in this report were made in accordance with the procedures given in ANSI C63.4 and the energy emitted by the device was founded to be within the limits applicable. I assume full responsibility for accuracy and completeness of these data.

Issued Date : JUL. 06, 1998

Test Engineer : Tien Lu Liao
(Tien Lu Liao)

Approve & Authorized Signer : Will Yauo
Will Yauo, Supervisor
EMI Test Site of ELECTRONICS
TESTING CENTER, TAIWAN

Table of Contents

Page

1. GENERAL INFORMATION	1
1.1 PRODUCT DESCRIPTION	1
1.2 CHARACTERISTICS OF DEVICE:	1
1.3 TEST METHODOLOGY	1
1.4 TEST FACILITY.....	2
2. DEFINITION AND LIMITS	2
2.1 DEFINITION	2
2.2 RESTRICTED BANDS OF OPERATION	2
2.3 LIMITATION	3
2.4 LABELING REQUIREMENT	4
2.5 USER INFORMATION	4
3. RADIATED EMISSION MEASUREMENT.....	5
3.1 APPLICABLE STANDARD	5
3.2 MEASUREMENT PROCEDURE	5
3.3 TEST DATA	7
3.4 FIELD STRENGTH CALCULATION.....	8
3.5 ACTIVATE TIME.....	8
3.6 CALCULATION OF DUTY FACTOR.....	8
<i>a. Full Cycle of The Pulse Train</i>	9
<i>b. Detail of The Pulse Train</i>	10
3.7 RADIATED TEST EQUIPMENT	11
3.8 MEASURING INSTRUMENT SETUP	11
3.9 RADIATED MEASUREMENT PHOTOS	12
4. BANDWIDTH OF EMISSION.....	13
4.1 APPLICABLE STANDARD PLOT GRAPHIC OF BANDWIDTH.....	13
4.2 BANDWIDTH TEST EQUIPMENT	13
4.3 PLOT GRAPHIC OF BANDWIDTH	13
5. CONDUCTED EMISSION MEASUREMENT	15
5.1 STANDARD APPLICABLE	15
5.2 MEASUREMENT PROCEDURE	15
5.3 CONDUCTED EMISSION DATA	16
5.4 RESULT DATA CALCULATION	19
5.5 CONDUCTED MEASUREMENT EQUIPMENT	19
5.6 PHOTOS OF CONDUCTION MEASURING SETUP	20

1. GENERAL INFORMATION

1.1 Product Description

a) Type of EUT	: Outdoor Motion Sensing Light Control Transmitter
b) Trade Name	: Heath Zenith
c) Model No.	: SL-5325-A
d) FCC ID	: BJ4-53PIR25ATX
e) Working Frequency	: 315 MHz
f) Power Supply	: AC 120V, 60Hz

1.2 Characteristics of Device:

- Features:
1. Turns on lighting when motion is detected.
 2. Automatically turns lighting off.
 3. Photocell keeps the lighting off during daylight hours.
 4. LED indicates motion was sensed (day or night).
 5. Turns indoor lights on when motion is detected.
 6. Sounds chime indoors when motion is detected outdoors.

- Requirements:
1. The Light Control requires 12-volts AC.
 2. If you want use Manual Mode, the control must be wired through a switch.
 3. Some codes require installation by a qualified electrician.
 4. This product is intended for use with the enclosed gasket and with a junction box marked for use in wet locations.

1.3 Test Methodology

Both conducted and radiated testing were performed according to the procedures in chapter 13 of ANSI C63.4.

The Outdoor Motion Sensing Light Control Transmitter under test was operated continuously in its normal operating mode for the purpose of the measurements. In order to secure the continuous operation of the device under test, rewiring in the circuit was done by the manufacturer so as to affect its intended operation.

The receiving antenna polarized horizontally was varied from 1 to 4 meters and the wooden turntable was rotated through 360 degrees to obtain the highest reading on the field strength meter or on the display of the spectrum analyzer. And also, each emission was to be maximized by changing the orientation of the Outdoor Motion Sensing Light Control Transmitter under test.

In order to determining the average value during one pulse train of the radiated power generated from the Outdoor Motion Sensing Light Control Transmitter under test, the encoded wave form in the time domain was used.

1.4 Test Facility

The open area test site and conducted measurement facility used to collect the radiated data is located on the roof top of Building at No.34, 5 Lirn, Din Fu Tsun, Lin Kou, Taipei, Taiwan, R.O.C.

This site has been fully described in a report submitted to your office, and accepted in a letter dated Feb. 10 , 1997.

2. DEFINITION AND LIMITS

2.1 Definition

Intentional radiator:

A device that intentionally generates and emits radio frequency energy by radiation or induction.

2.2 Restricted Bands of Operation

Only spurious emissions are permitted in any of the frequency bands listed below:

MHz	MHz	MHz	GHz
0.090 - 0.110	16.42-16.423	399.9-410	4.5-5.25
0.495 - 0.505 **	16.69475 - 16.69525	608-614	5.35-5.46
2.1735 - 2.1905	16.80425 - 16.80475	960-1240	7.25-7.75
4.125-4.128	25.5-25.67	1300-1427	8.025-8.5
4.17725-4.17775	37.5-38.25	1435-1626.5	9.0-9.2
4.20725-4.20775	73-74.6	1645.5-1646.5	9.3-9.5
6.215-6.218	74.8-75.2	1660-1710	10.6-12.7
6.26775-6.26825	108-121.94	1718.8-1722.2	13.25-13.4
6.31175-6.31225	123-138	2200-2300	14.47-14.5
8.291-8.294	149.9-150.05	2310-2390	15.35-16.2
8.362-8.366	156.52475 - 156.52525	2483.5-2500	17.7-21.4
8.37625-8.38675	156.7-156.9	2655-2900	22.01-23.12
8.41425-8.41475	162.0125-167.17	3260-3267	23.6-24.0
12.29-12.293	167.72-173.2	3332-3339	31.2-31.8
12.51975-12.52025	240-285	3345.8-3358	36.43-36.5
12.57675-12.57725	322-335.4	3360-4400	Above 38.6
13.36-13.41			

Remark "***" : Until February 1, 1999, this restricted band shall be 0.490-0.510 MHz

2.3 Limitation

(1) Conducted Emission Limits :

For an intentional radiator which is designed to be connected to the public utility (AC) power line, the conducted limit is the following:

Frequency (MHz)	Emission (μ V)	Emission (dB μ V)
0.45 - 30.0	250	48.0

(2) Radiated Emission Limits :

According to 15.231 ,Periodic operation in the band 40.66-40.70 MHz and above 70 MHz, the field strength of emissions from intentional radiators operated under this section shall not exceed the following:

Frequency Band (MHz)	Field strength of Fundamental (uV/m)	Field strength of Spurious (uV/m)
40.66-40.70	2250	225
70-130	1250	125
130-174	*1,250 to 3,750	*125 to 375
174-260	3750	375
260-470	*3,750 to 12,500	*375 to 1250
Above 470	12500	1250

* Linear interpolations.

According to 15.235, the field strength of emissions from intentional radiators operated under these frequency bands shall not exceed the following:

Fundamental Frequency (MHz)	Field Strength of Fundamental	
	μ V/meter	dB μ V/meter
49.82 - 49.90	10000	80

Field strength limits are at the distance of 3 meters, emissions radiated outside of the specified bands, shall be according to the general radiated limits in 15.209,as following table:

Other Frequencies (MHz)	Field Strength of Fundamental	
	μ V/meter	dB μ V/meter
30 - 88	100	40.0
88 - 216	150	43.5
216 - 960	200	46.0
Above 960	500	54.0

As shown in 15.35(b), for frequencies above 1000MHz, the field strength limits are based on average detector, however, the peak field strength of any emission shall not exceed the maximum permitted average limits, specified above by more than 20 dB under any condition of modulation.

(3) Limit of transmission time

- a) A manually operated Outdoor Motion Sensing Light Control Transmitter shall employ a switch that will automatically deactivate the Outdoor Motion Sensing Light Control Transmitter within not more than 5 seconds of being released.
- b) A Outdoor Motion Sensing Light Control Transmitter activated automatically shall cease transmission within 5 seconds after activation.

2.4 Labeling Requirement

The device shall bear the following statement in a conspicuous location on the device :

This device complies with part 15 of the FCC Rules. Operation is subject to the following two conditions: (1) This device may not cause harmful interference, and (2) this device must accept any interference received, including interference that may cause undesired operation.

2.5 User Information

The users manual or instruction manual for an intentional or unintentional radiator shall caution the user that changes or modifications not expressly approved by the party responsible for compliance could void the user's authority to operate the equipment.

3. RADIATED EMISSION MEASUREMENT

3.1 Applicable Standard

For periodic operation intentional radiator, the radiated emission shall comply with § 15.231(b).

3.2 Measurement Procedure

1. Setup the configuration per figure 1 and 2 for frequencies measured below and above 1 GHz respectively. Turn on EUT and make sure that it is in normal function.
2. For emission frequencies measured below 1 GHz, a pre-scan is performed in a shielded chamber to determine the accurate frequencies of higher emissions will be checked on a open test site. As the same purpose, for emission frequencies measured above 1 GHz, a pre-scan also be performed with a 1 meter measuring distance before final test.
3. For emission frequencies measured below and above 1 GHz, set the spectrum analyzer on a 100 kHz and 1 MHz resolution bandwidth respectively for each frequency measured in step 2.
4. The search antenna is to be raised and lowered over a range from 1 to 4 meters in horizontally polarized orientation. Position the highness when the highest value is indicated on spectrum analyzer, then change the orientation of EUT on test table over a range from 0 ° to 360 ° with a speed as slow as possible, and keep the azimuth that highest emission is indicated on the spectrum analyzer. Vary the antenna position again and record the highest value as a final reading. A RF test receiver is also used to confirm emissions measured.
5. Repeat step 4 until all frequencies need to be measured were complete.
6. Repeat step 5 with search antenna in vertical polarized orientations.
7. Check the three frequencies of highest emission with varying the placement of cables (if any) associated with EUT to obtain the worse case and record the result.

Figure 1 : Frequencies measured below 1 GHz configuration

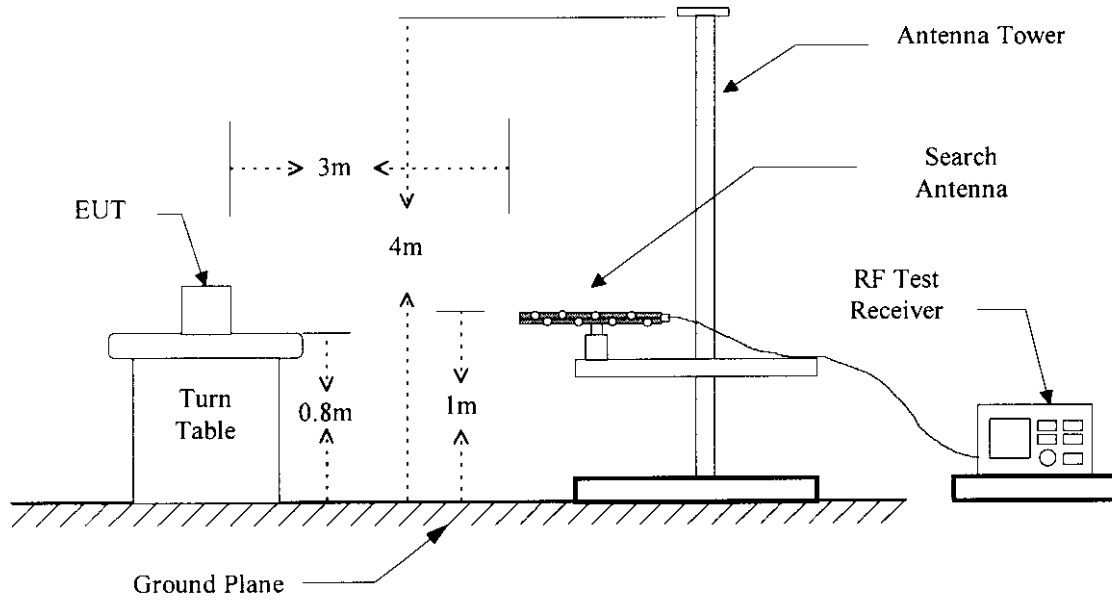
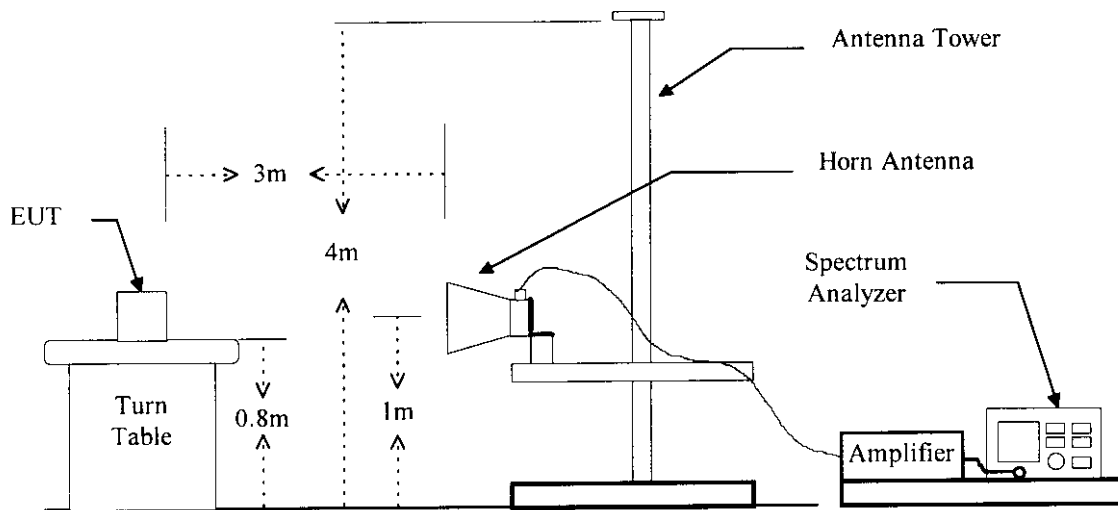

Figure 2 : Frequencies measured above 1 GHz configuration



3.3 Test Data

Temperature : 26 °C
 Humidity : 59 %
 Operated mode : Transmitting
 Test Date : JUN. 19, 1998

Frequency (MHz)	Ant Pol H/V	Reading (dBuV) Peak	Factor (dB)		Result @3m (dBuV/m)		Limit @3m (dBuV/m)		Margin (dB)	Table Degree (Deg.)	Ant. High (m)
			C	D	Peak	Ave.	Peak	Ave.			
314.791	V	98.8	-6.8	-19.6	92.0	72.4	95.0	75.0	-2.6	0	1.20
629.408	H	73.3	-3.2	-19.6	70.1	50.5	75.0	55.0	-4.5	180	1.00
943.969	H	56.8	3.1	-19.6	59.9	40.3	75.0	55.0	-14.7	0	1.00
1260.564	H	67.0	-8.6	-19.6	58.4	38.8	75.0	55.0	-16.2	180	2.00
*1575.624	H	58.8	-7.1	-19.6	51.7	32.1	74.0	54.0	-21.9	0	2.00
1890.655	H	51.4	-5.2	-19.6	46.2	26.6	75.0	55.0	-28.4	0	1.50
*2205.873	H	53.2	-3.8	-19.6	49.4	29.8	74.0	54.0	-24.2	0	2.00
2520.997	H	50.9	-2.6	-19.6	48.3	28.7	75.0	55.0	-26.3	180	2.00
*2836.535	H/V	--	-1.7	-19.6	--	--	74.0	54.0	--	--	--
3151.660	H/V	--	-0.8	-19.6	--	--	75.0	55.0	--	--	--

Note :

1. Factor C means "corrected", and that includes antenna factor, cable loss, amplifier gain (if any). And Factor D means "Duty", that is for calculating the average value and derived from section 3.6 in this test report.
2. Result = Reading + C. Factor
Ave. = Peak Value + D Factor
3. The limit for spurious emissions is referred to FCC class B.

If the measured frequencies fall in the restricted frequency band, the limit employed is § 15.209 general requirement when frequencies are below or equal to 1 GHz. And the measuring instrument is set to quasi peak detector function, no duty factor applied.

3.4 Field Strength Calculation

The field strength is calculated by adding the Antenna Factor and Cable Factor, and subtracting the Amplifier Gain (if any) from the measured reading. For the limit is employed average value, therefore the peak value can be transferred to average value by subtracting the duty factor. The basic equation with a sample calculation is as follows:

$$\mathbf{Peak = Reading + Corrected Factor}$$

where

Corr. Factor = Antenna Factor + Cable Factor - Amplifier Gain (if any)

And the average value is

$$\mathbf{Average = Peak Value + Duty Factor}$$

Note : If the measured frequencies are fall in the restricted frequency band, the limit employed must be quasi peak value when frequencies are below or equal to 1 GHz. And the measuring instrument is set to quasi peak detector function.

3.5 Activate Time

This Outdoor Motion Sensing Light Control Transmitter is operated by Manual, and Activate Time is less than 5 second after being released.

3.6 Calculation of Duty Factor

The total period of pulse train is 100 ms, and the total duty is 10.5 ms, and the duty factor is calculated with following formula :

$$20 \log \frac{\text{Total Duty}}{\text{Period of Pulse Train}} = -19.6 \text{ (dB)}$$

Details please see following two plotted pages.

a. Full Cycle of The Pulse Train

$$20\log\left|\frac{4 \times 1.171\mu s}{100ms}\right| = 20\log\left|\frac{10.5ms}{100ms}\right| = -19.6 \text{ (dB)}$$

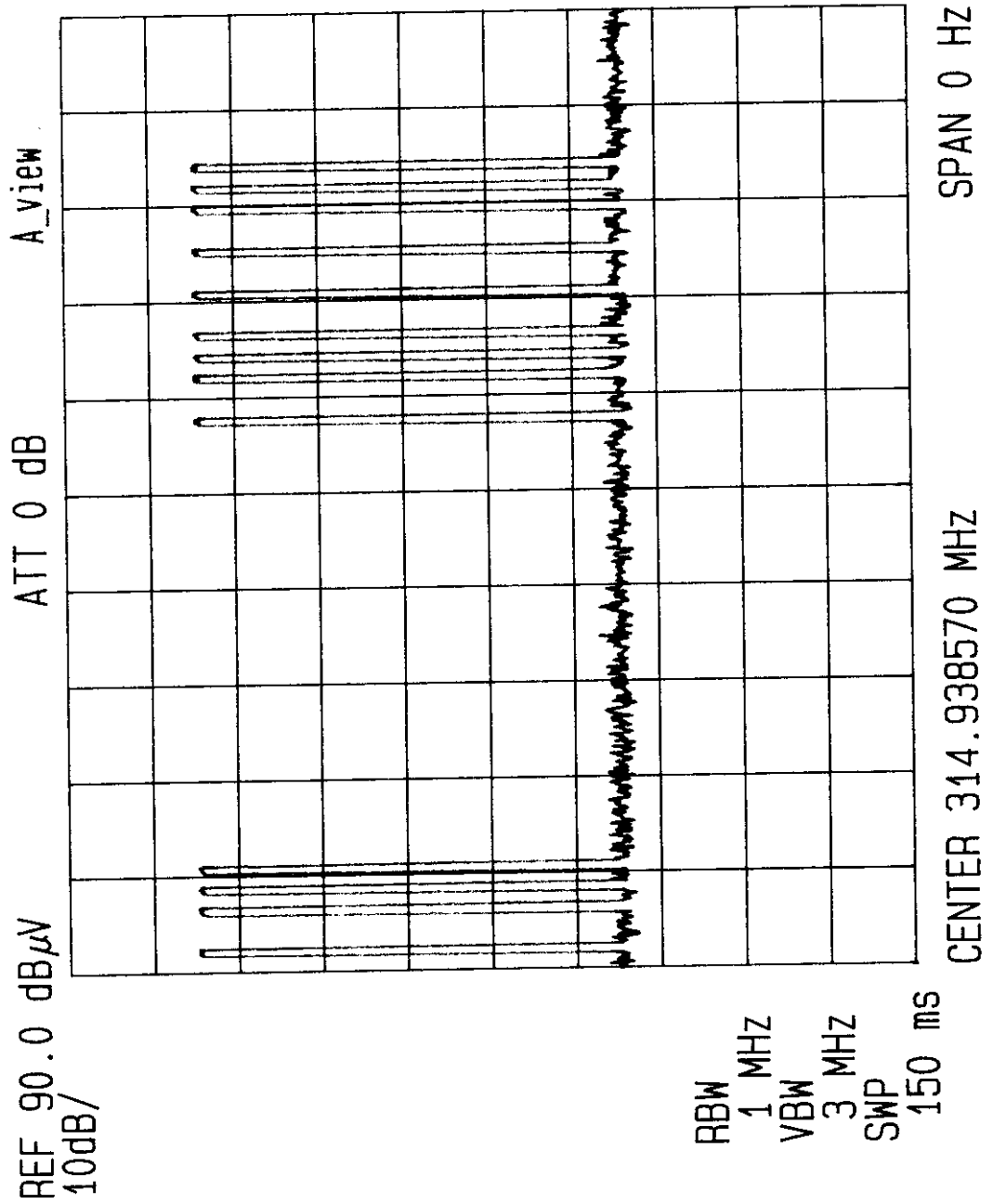

b. Detail of The Pulse Train

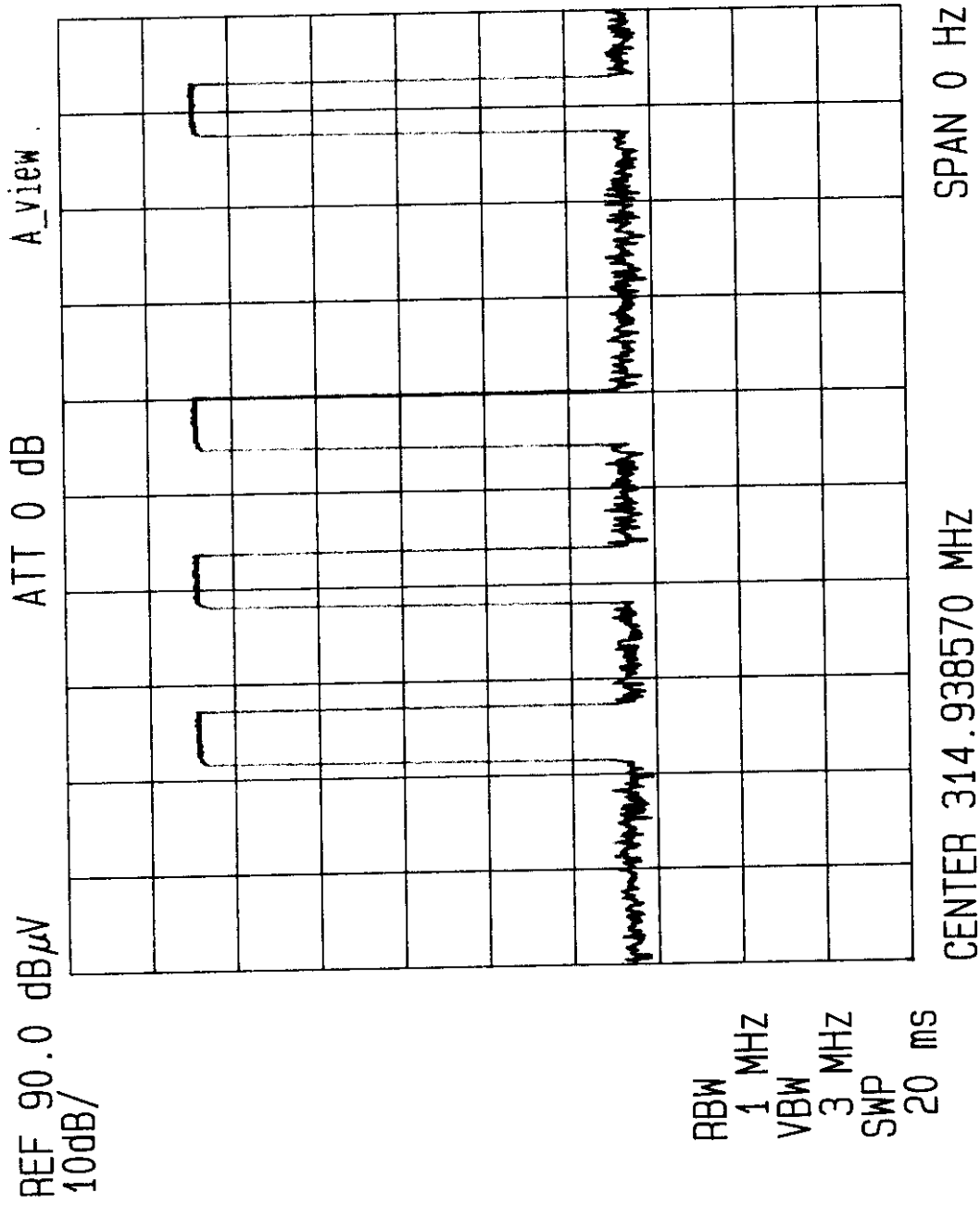

3.7 Radiated Test Equipment

Equipment	Manufacturer	Model No.	Next Cal. Date
Spectrum Analyzer	Hewlett-Packard	8568B	10/16/1998
Pre-selector	Hewlett-Packard	85685A	10/16/1998
Quasi Peak Detector	Hewlett-Packard	85650A	10/07/1998
Spectrum Analyzer	Adventest	R3271	09/02/1998
RF Test Receiver	Rohde & Schwarz	ESVS 30	12/10/1998
Horn Antenna	EMCO	3115	08/05/1998
Log periodic Antenna	EMCO	3146	08/05/1998
Biconical Antenna	EMCO	3110	08/05/1998
Preamplifier	Hewlett-Packard	8449B	05/08/1999
Preamplifier	Hewlett-Packard	8447D	12/23/1998

3.8 Measuring Instrument Setup

Explanation of measuring instrument setup in frequency band measured is as following :

Frequency Band (MHz)	Instrument	Function	Resolution bandwidth	Video Bandwidth
30 to 1000	RF Test Receiver	Quasi Peak	120 kHz	N/A
	Spectrum Analyzer	Peak	100 kHz	100 kHz
Above 1000	Spectrum Analyzer	Peak	1 MHz	1 MHz

4. BANDWIDTH OF EMISSION

4.1 Applicable Standard Plot Graphic of Bandwidth

Per FCC rule § 15.231(c), the permitted emission bandwidth is no wider than 0.25% of the center frequency for devices operating above 70 MHz and below 900 MHz.

4.2 Bandwidth Test Equipment

Equipment	Manufacturer	Model No.	Next Cal. Date
Spectrum Analyzer	Adventest	R3271	09/02/1998
Plotter	Hewlett-Packard	7440A	N/A

4.3 Plot Graphic of Bandwidth

The emission bandwidth for this transmitter is

$$315.049 \times 0.25\% = 787.6 \text{ KHz}$$

Plotted graphics please see following page.

Emission Bandwidth

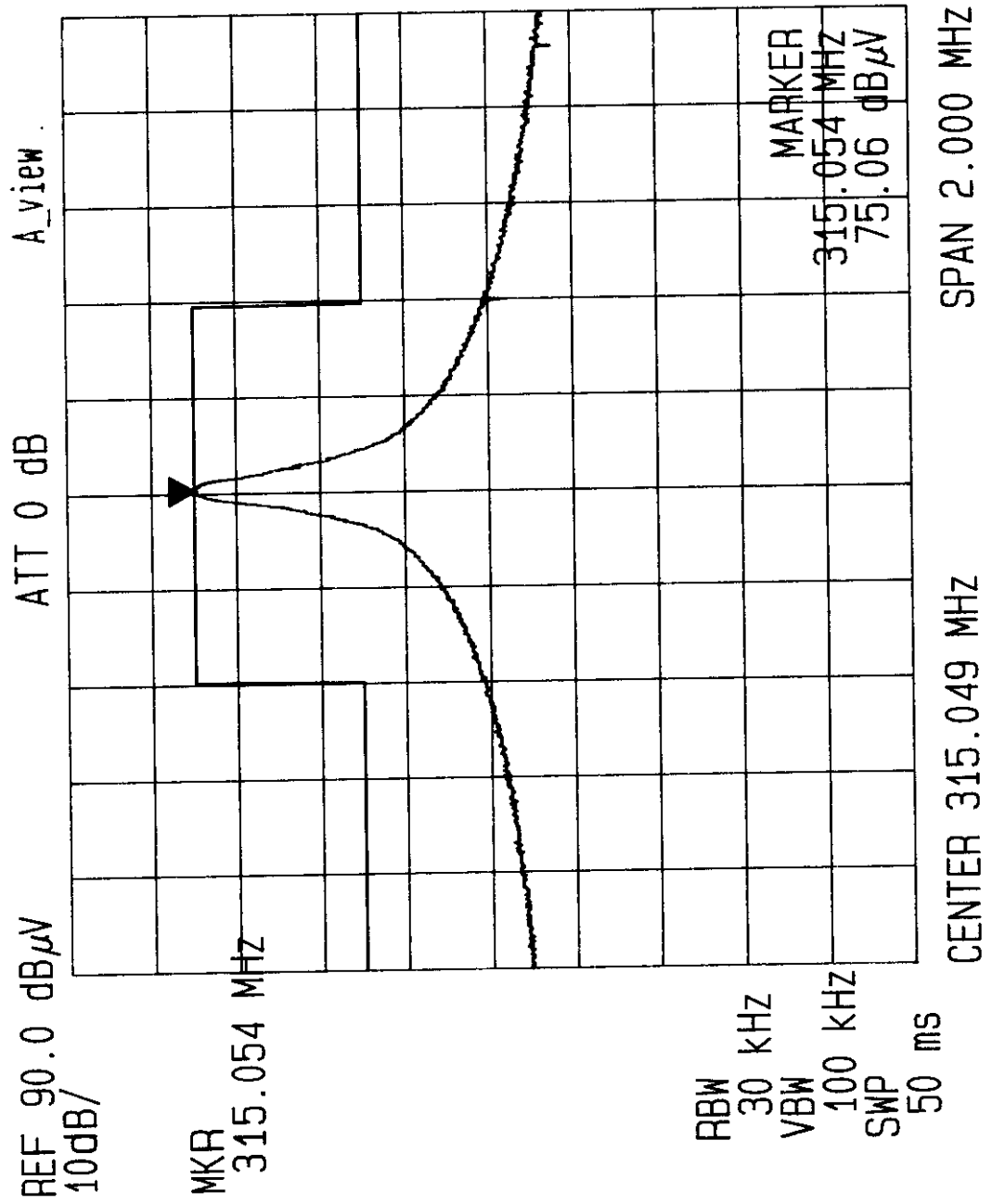

5. CONDUCTED EMISSION MEASUREMENT

5.1 Standard Applicable

For intentional device, Line Conducted Emission Limits are in accordance to § 15.207(a), any emissions level shall not exceed 48 dBuV.

5.2 Measurement Procedure

1. Setup the configuration per figure 3.
2. A preliminary scan with a spectrum monitor is performed to identify the frequency of emission that has the highest amplitude relative to the limit by operating the EUT in selected modes of operation, typical cable positions, and with a typical system configuration.
3. Record the 6 or 8 highest emissions relative to the limit.
4. Measure each frequency obtained from step 3 by a test receiver set on quasi peak detector function, and then record the accuracy frequency and emission level. If all emissions measured in the specified band are attenuated more than 20 dB from the limit, this step would be ignored, and the peak detector function would be used.
5. Confirm the highest three emissions with variation of the EUT cable configuration and record the final data.
6. Repeat all above procedures on measuring each operation mode of EUT.

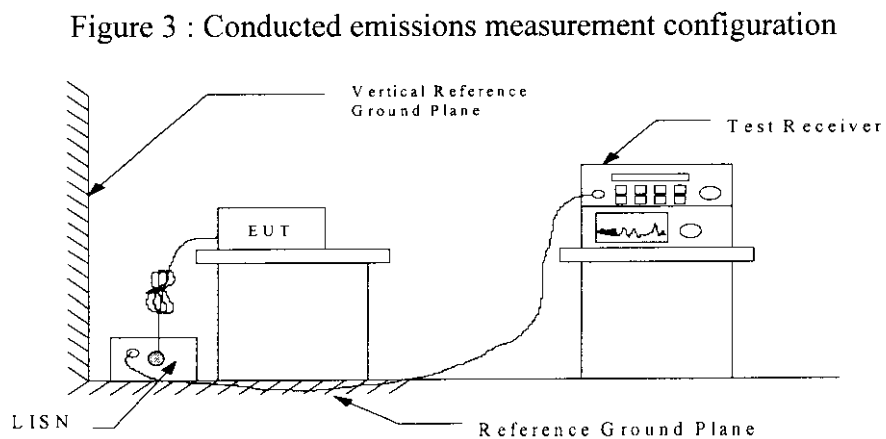

5.3 Conducted Emission DataOperation Mode : TransmittingTest Date : JUL. 03, 1998Temperature : 50 °CHumidity: 23%

Frequency (MHz)	Reading (dBuV)		Factor (dB)	Result (dBuV)		Limit (dBuV)	Margin (dB)
	Va	Vb		Va	Vb		
0.547	17.8	16.8	0.2	18.0	17.0	48.0	-30.0
1.825	19.4	18.6	0.3	19.7	18.9	48.0	-28.3
3.639	26.9	25.6	0.3	27.2	25.9	48.0	-20.8
4.548	25.8	22.4	0.3	26.1	22.7	48.0	-21.9
5.457	21.7	19.2	0.3	22.0	19.5	48.0	-26.0
15.830	17.8	16.0	0.8	18.6	16.8	48.0	-29.4

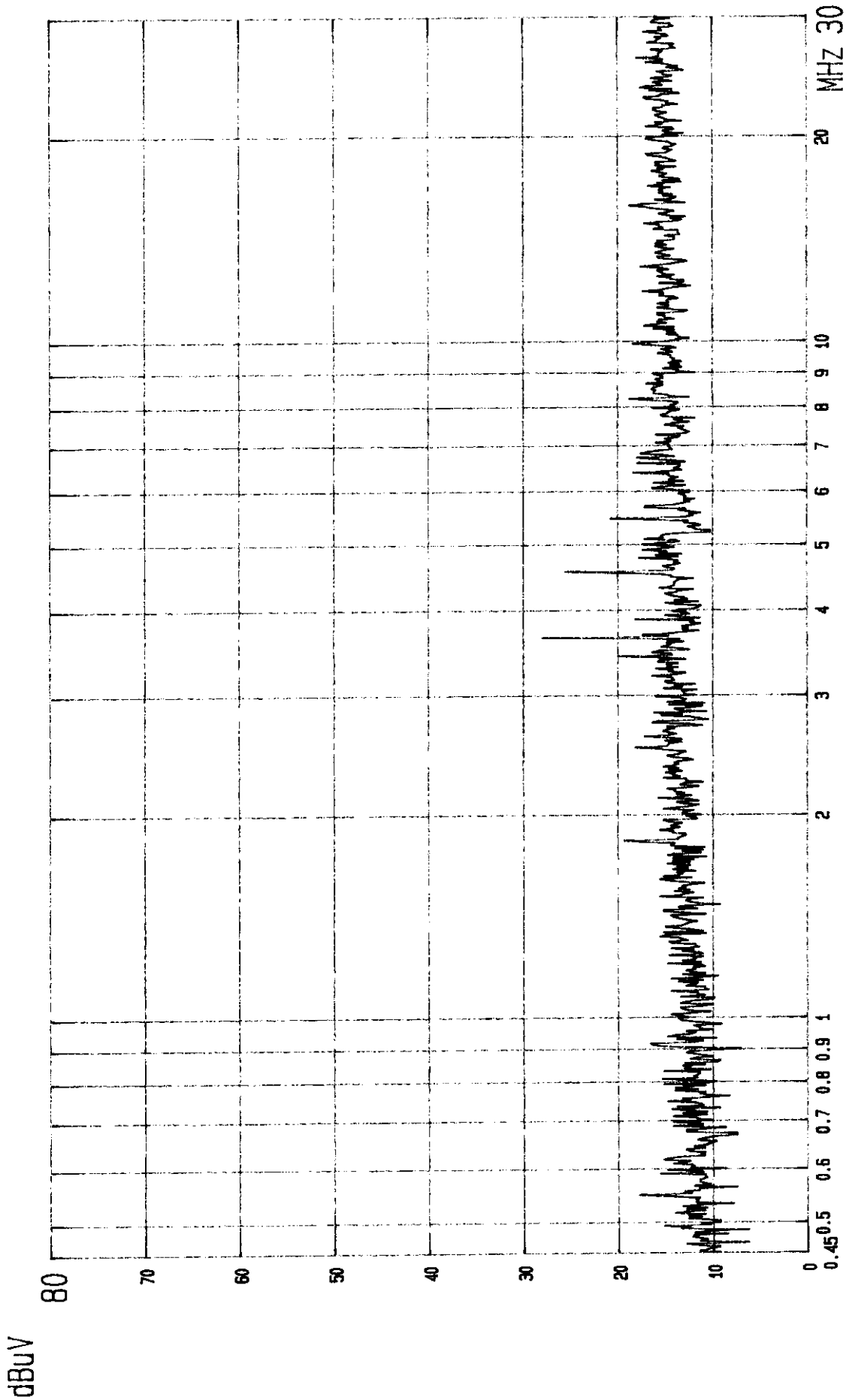

CLASS B LIMIT
ETC EMI LAB.
B: QP.
LISN: Va

TRANSMITTER
POWER: 120V/60HZ
EUT: TX
MODE: TX

FCC CONDUCTED TEST
MODEL: SL-5325-A
EUT: TRANSMITTER

dBuV

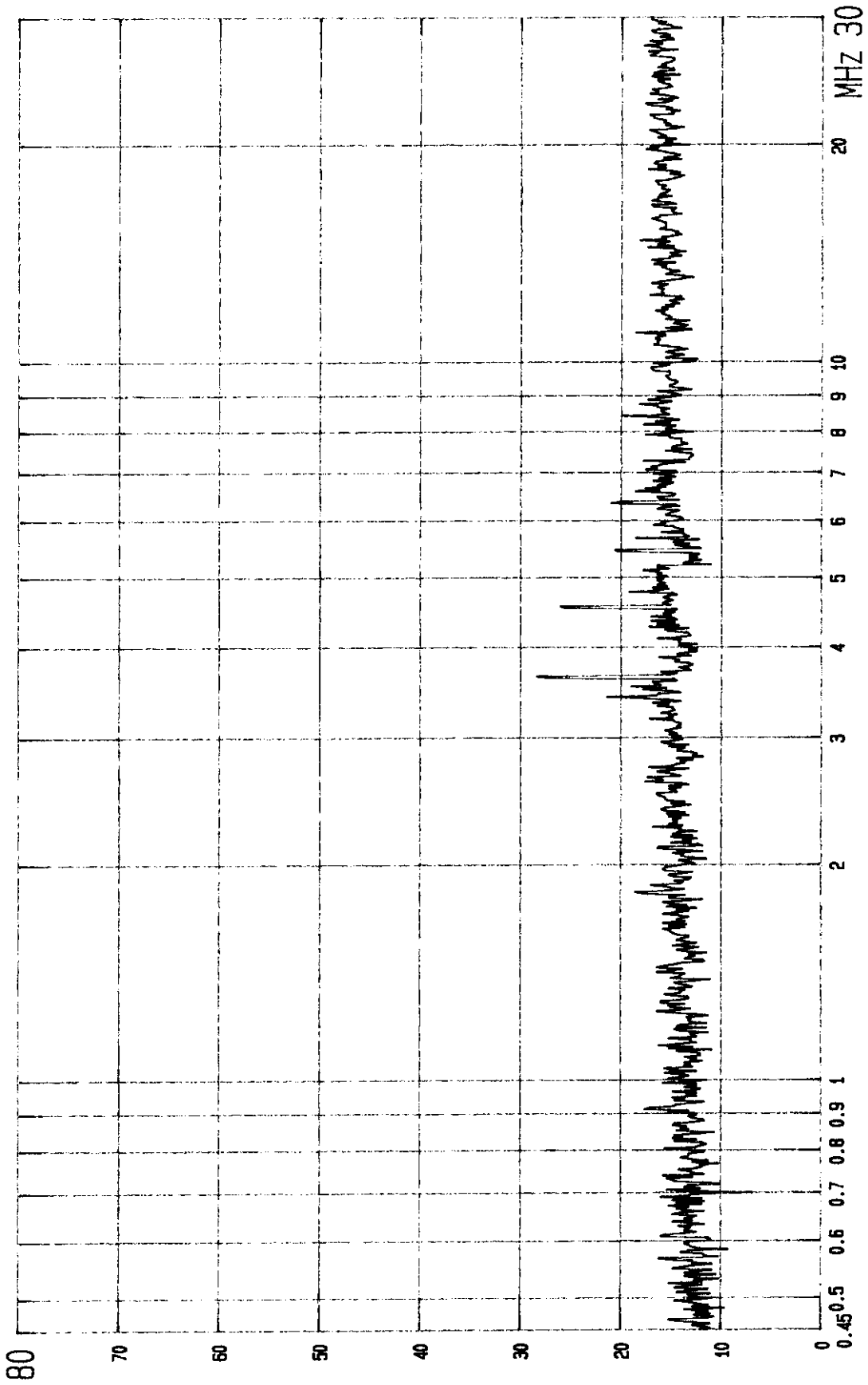

FCC CONDUCTED TEST EUT: TRANSMITTER 8: QP CLASS B LIMIT
MODEL: SL-5325-A MODE: TX POWER: 120V/60HZ LISN: Vb ETC EMI LAB.

5.4 Result Data Calculation

The result data is calculated by adding the LISN Factor to the measured reading. The basic equation with a sample calculation is as follows:

$$\mathbf{RESULT = READING + LISN FACTOR}$$

Assume a receiver reading of 22.5 dB μ V is obtained, and LISN Factor is 0.1 dB, then the total of disturbance voltage is 22.6 dB μ V.

$$\text{RESULT} = 22.5 + 0.1 = 22.6 \text{ dB } \mu \text{ V}$$

$$\begin{aligned} \text{Level in } \mu \text{ V} &= \text{Common Antilogarithm}[(22.6 \text{ dB } \mu \text{ V})/20] \\ &= 13.48 \mu \text{ V} \end{aligned}$$

5.5 Conducted Measurement Equipment

The following test equipment are used during the conducted test .

Equipment	Manufacturer	Model No.	Next Cal. Date
RF Test Receiver	Rohde and Schwarz	ESH3	01/04/1999
Spectrum Monitor	Rohde and Schwarz	EZM	N.C.R.
Line Impedance Stabilization network	Kyoritsu	KNW-407	12/01/1998
Plotter	Hewlett-Packard	7440A	N/A
Shielded Room	Riken	N/A	N.C.R.