

TABLE OF CONTENTS LIST

APPLICANT: AUDIOVOX CORPORATION

FCC ID: BGAFR560

TEST REPORT:

PAGE 1.....COVER SHEET - GENERAL INFORMATION & TECHNICAL DESCR.
PAGE 2.....TECHNICAL DESCRIPTION CONTINUED AND RF POWER OUTPUT
PAGE 3.....MODULATION CHARACTERISTICS AND EMISSION BANDWIDTH
PAGE 4.....METHOD OF MEASURING OCCUPIED BANDWIDTH
PAGE 5.....SPURIOUS EMISSIONS AT ANTENNA TERMINALS
PAGE 5.....FIELD STRENGTH OF SPURIOUS EMISSIONS
PAGE 6.....METHOD OF MEASURING RADIATED SPURIOUS EMISSIONS
PAGE 7.....FREQUENCY STABILITY
PAGE 8.....LIST OF TEST EQUIPMENT

EXHIBITS CONTAINING:

EXHIBIT 1.....FCC ID LABEL SAMPLE
EXHIBIT 2.....SKETCH OF FCC ID LABEL LOCATION
EXHIBIT 3A.....EXTERNAL FRONT VIEW PHOTOGRAPH
EXHIBIT 3B.....EXTERNAL REAR VIEW PHOTOGRAPH
EXHIBIT 3C.....INTERNAL COMPONENT CHASSIS VIEW PHOTOGRAPH
EXHIBIT 3D.....INTERNAL COMPONENT VIEW PHOTOGRAPH
EXHIBIT 3E.....INTERNAL SOLDER CHASSIS VIEW PHOTOGRAPH
EXHIBIT 3F.....INTERNAL SOLDER VIEW PHOTOGRAPH
EXHIBIT 4A.....BLOCK DIAGRAM - MOTHER BOARD
EXHIBIT 4B.....BLOCK DIAGRAM - RF MODULE
EXHIBIT 5A.....SCHEMATIC - MOTHER BOARD
EXHIBIT 5B.....SCHEMATIC - RF MOODULE
EXHIBIT 6A-6D.....THEORY OF OPERATION
EXHIBIT 7A-7B.....TUNING PROCEDURES
EXHIBIT 8A-8C.....USER'S MANUAL
EXHIBIT 9.....AUDIO FREQUENCY RESPONSE GRAPH
EXHIBIT 10A.....MODULATION LIMITING - 300 Hz
EXHIBIT 10B.....MODULATION LIMITING - 1000 Hz
EXHIBIT 10C.....MODULATION LIMITING - 3000 Hz
EXHIBIT 11.....AUDIO LOW PASS FILTER GRAPH
EXHIBIT 12A.....OCCUPIED BANDWIDTH CW PLOT
EXHIBIT 12B.....OCCUPIED BANDWIDTH PLOT

APPLICANT: AUDIOVOX CORPORATION

FCC ID: BGAFR560

REPORT #: T:\CUS\A\AUDIOVOX\191AK0\AUD191A0.RPT

PAGE: TABLE OF CONTENTS

GENERAL INFORMATION REQUIRED
FOR TYPE ACCEPTANCE

2.1033(c)(1)(2) AUDIOVOX CORPORATION will manufacture the
FCCID: BGAFR560 FAMILY RADIO SERVICES 14 CHANNEL
TRANSCEIVER in quantity, for use under FCC RULES
PART 95.

2.1033 (c) TECHNICAL DESCRIPTION

2.1033(c)(3) Instruction book. A draft copy of the instruction
manual is included as EXHIBIT 8A-8C.

2.1033(c) (4) Type of Emission: 10K0F3E
95.629

Bn = 2M + 2DK

M = 3000

D = 2.0K

Bn = 2(3.0)+2(2.0) = 10.0K

Authorized Bandwidth 12.5KHz

2.1033(c)(5) Frequency Range: 1. 462.5625 8. 467.5625
95.627 2. 462.5875 9. 467.5875
3. 462.6125 10. 467.6125
4. 462.6375 11. 467.6375
5. 462.6625 12. 467.6625
6. 462.6875 13. 467.6875
7. 462.7125 14. 467.7125 MHz

2.1033(c)(6)(7) Power Output shall not exceed 0.500Watts effective
95.637 radiated power. There can be no provisions for
95.647 increasing the power or varying the power. The Maximum
Output Power Rating: 300 milliWatts
effective radiated power.

95.645 The antenna is an integral part to the unit, it cannot
be removed without rendering the unit inoperative. In
order to remove the antenna the case must unscrewed,
then the PCB assemblies must be removed then the
antenna can be removed.

2.1033(c)(8) DC Voltages and Current into Final Amplifier:

FINAL AMPLIFIER ONLY

Vce = 4.5 Volts DC Ice = 0.12A.

Pin = 0.54 Watts

2.1033(c)(9) Tune-up procedure. The tune-up procedure is included
as Exhibit 7A-7B.

APPLICANT: AUDIOVOX CORPORATION

FCC ID: BGAFR560

REPORT #: T:\CUS\A\AUDIOVOX\191AK0\AUD191A0.RPT

PAGE #: 1

- 2.1033(c)(10) Complete Circuit Diagrams: The circuit diagram is included as EXHIBIT 5A-5B of this report. The block diagrams are included as EXHIBIT 4A-4B of this report.
- 2.1033(c)(11) A photograph or a drawing of the equipment identification label is included as EXHIBIT 1.
- 2.1033(c)(12) Photographs(8"X10") of the equipment of sufficient clarity to reveal equipment construction and layout, including meters, labels for controls, including any view under shields are included as EXHIBIT 3A-3F.
- 2.1033(c)(13) Digital modulation is not allowed.
- 2.1033(c)(14) The data required by 2.1046 through 2.1057 is submitted below.
- 2.1046(a) RF power output.
- 95.637 RF power is measured by measuring the radiated power at 3 meters and then replacing the transmitter with a signal generator to determine the effective radiated power. The ERP shall not exceed 0.500 Watts.

MEASURED POWER OUTPUT = 300 milliWatts ERP

R.F. POWER OUTPUT
TEST SET UP

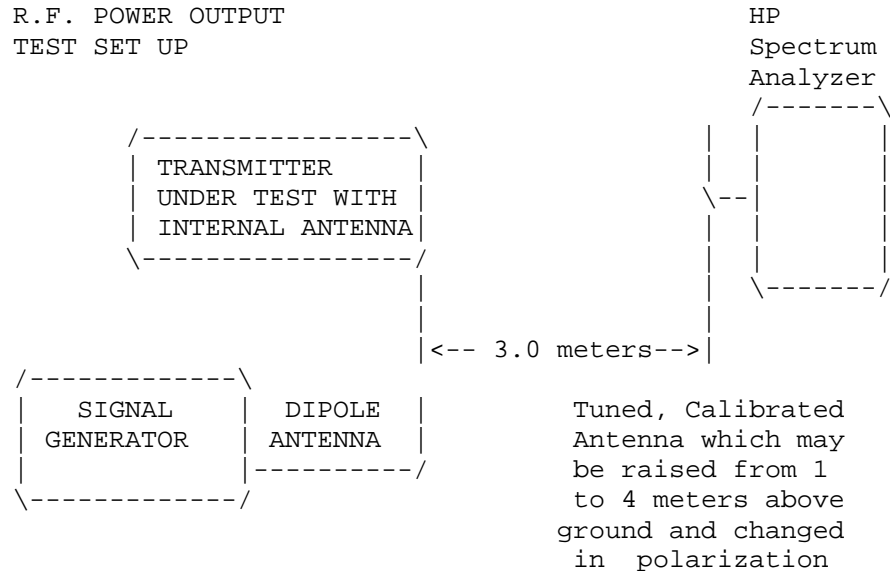

Equipment placed 1 meter above ground on a rotatable platform.

APPLICANT: AUDIOVOX CORPORATION
FCC ID: BGAFR560
REPORT #: T:\CUS\A\AUDIOVOX\191AK0\AUD191A0.RPT
PAGE #: 2

2.1047(a)(b) Modulation characteristics:

AUDIO FREQUENCY RESPONSE

The audio frequency response was measured in accordance with TIA/EIA Specification 603. The audio frequency response curve is shown on the next page. The audio signal was fed into a dummy microphone circuit and into the microphone connector. The input required to produce 30 percent modulation level was measured. See EXHIBIT #: 9.

2.1047(b) Audio input versus modulation

The audio input level needed for a particular percentage of modulation was measured in accordance with TIA/EIA Specification 603. The audio input curves versus modulation are on the following pages. Curves are provided for audio input frequencies of 300, 1000, and 3000 Hz. See EXHIBIT # 10A-10C.

95.635(b) Post Limiter Filter The filter must be between the modulation limiter and the modulated stage. At any frequency between 3 & 20KHz the filter must have an attenuation of $60 \log (f/3)$ greater than the attenuation at 1KHz. See the EXHIBIT #: 11.

2.989(c) EMISSION BANDWIDTH:

95.633(b)(1)(3)(7)

Data in the plots shows that the sidebands from greater than 50% to 100% of the authorized bandwidth must be attenuated by at least 25dB and from 100 to 250% the sidebands must be attenuated by at least 35dB. Beyond 250% the sidebands must be attenuated by at least $43 + \log_{10}(TP)$. The transmitter was modulated with 2500 Hz, adjusted for 50% modulation plus 16 dB. The spectrum analyzer was set with the unmodulated carrier at the top of the screen. The test procedure diagram and occupied bandwidth PLOTS follow.

APPLICANT: AUDIOVOX CORPORATION
FCC ID: BGAFR560
REPORT #: T:\CUS\A\AUDIOVOX\191AK0\AUD191A0.RPT
PAGE #: 3

Radiotelephone transmitter with modulation limiter.

Test procedure diagram

OCCUPIED BANDWIDTH MEASUREMENT

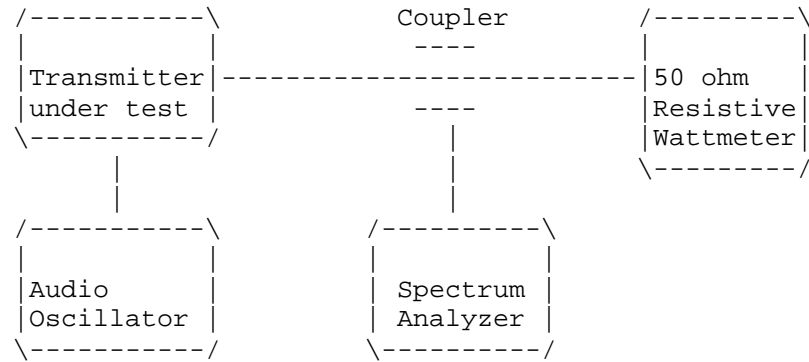

APPLICANT: AUDIOVOX CORPORATION
FCC ID: BGAFR560
REPORT #: T:\CUS\A\AUDIOVOX\191AK0\AUD191A0.RPT
PAGE #: 4

2.1051 Not Applicable, no antenna terminal allowed.

2.1053 UNWANTED RADIATION:
95.635(b)(7)

REQUIREMENTS: Emissions must be attenuated by at least the following below the output of the transmitter.

$$43 + 10\log(TP) = 43 + 10\log(0.002) = 16.01\text{dB}$$

TEST DATA:

EMISSION FREQ. MHz	METER READING @ 3m dBuV	COAX LOSS dB	ACF dB	FIELD STRNGTH dBuV/m	ATT. dBuV/m	MARGIN dB	ANT.
462.69	102.90	1.60	18.44	122.94	0.0	1.43	V
925.36	42.10	2.90	24.10	69.10	53.84	13.84	V
1388.05	53.60	1.00	25.55	80.15	42.79	2.79	V
1850.71	52.90	1.01	27.40	81.31	41.63	1.63	V
2313.34	41.90	1.08	28.78	71.76	51.18	11.18	V
2775.97	42.90	1.15	29.94	73.99	48.95	8.95	V
3238.66	39.90	1.22	31.10	72.21	50.73	10.73	V
3701.35	32.80	1.29	32.25	66.34	56.60	16.60	V
4163.96	28.00	1.35	33.18	62.54	60.40	20.40	V
4626.90	27.00	1.42	33.71	62.13	60.81	20.81	V

MARGIN = (Field strength of Fund - 40dB) - FS OF EMISSION

METHOD OF MEASUREMENT: The procedure used was C63.4-1992 for intentional radiators. The spectrum was scanned from 30 to at least the tenth harmonic of the fundamental using a HP model 8566B spectrum analyzer, an Eaton model 94455-1 Biconical Antenna, ElectroMetrics antennas models TDA, TDS-25-1, TDS-25-2 and RGA-180. Measurements were made at the open field test site of TIMCO ENGINEERING INC. located at 849 N.W. State Road 45, Newberry, FL 32669.

APPLICANT: AUDIOVOX CORPORATION
FCC ID: BGAFR560
REPORT #: T:\CUS\A\AUDIOVOX\191AK0\AUD191A0.RPT
PAGE #: 5

2.1053
95.631(b)(8)(9)

UNWANTED RADIATION:

Method of Measuring Radiated Spurious Emissions

Hewlett Packard
Spectrum
Analyzer
HP8566B

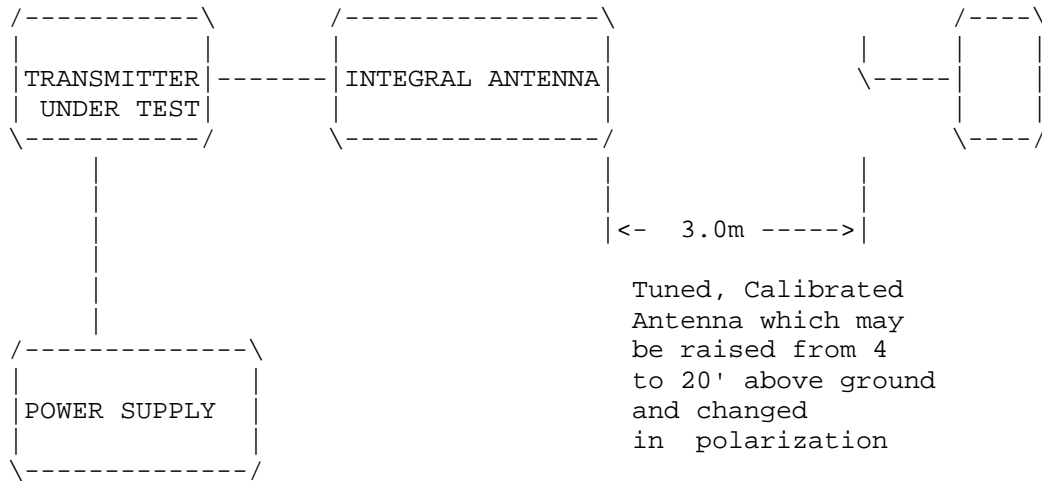

Tuned, Calibrated
Antenna which may
be raised from 4
to 20' above ground
and changed
in polarization

Equipment placed 4' above ground
on a rotatable platform.

APPLICANT: AUDIOVOX CORPORATION
FCC ID: BGAFR560
REPORT #: T:\CUS\A\AUDIOVOX\191AK0\AUD191A0.RPT
PAGE #: 6

2.1055

Frequency stability:

Temperature and voltage tests were performed to verify that the frequency remains within the 0.00025%, 2.5 ppm specification limit. The test was conducted as follows: The transmitter was placed in the temperature chamber at 25 degrees C and allowed to stabilize for one hour. The transmitter was keyed ON for one minute during which four frequency readings were recorded at 15 second intervals. The worse case number was taken for temperature plotting. The assigned channel frequency was considered to be the reference frequency. The temperature was then reduced to -30 degrees C after which the transmitter was again allowed to stabilize for one hour. The transmitter was keyed ON for one minute, and again frequency readings were noted at 15 second intervals. The worst case number was recorded for temperature plotting. This procedure was repeated in 10 degree increments up to + 50 degrees C.

Readings were also taken at plus and minus 15% of the battery voltage of 4.5 VDC.

MEASUREMENT DATA:

Assigned Frequency (Ref. Frequency): 462.712 500

TEMPERATURE C	FREQUENCY MHz	PPM
REFERENCE_____	462.712 500	00.00
-30_____	462.712 511	0.02
-20_____	462.712 131	-0.80
-10_____	462.712 280	-0.48
0_____	462.712 480	-0.04
+10_____	462.712 605	+0.23
+20_____	462.712 447	-0.11
+30_____	462.712 207	-0.63
+40_____	462.712 075	-0.92
+50_____	462.712 315	-0.40

-15% BATT. End-Point 3.825Vdc 462.712 326 -0.38
+15% BATT. End-Point 5.175Vdc 462.712 311 -0.41

RESULTS OF MEASUREMENTS: The maximum frequency variation over the temperature range was -0.80 to +0.23 ppm. The maximum frequency variation with voltage was -0.41ppm.

APPLICANT: AUDIOVOX CORPORATION
FCC ID: BGAFR560
REPORT #: T:\CUS\A\AUDIOVOX\191AK0\AUD191A0.RPT
PAGE #: 7

APPLICANT: AUDIOVOX CORPORATION

FCC ID: BGAFR560

TEST EQUIPMENT LIST

1. Spectrum Analyzer: HP 8566B-Opt 462, S/N 3138A07786, w/
preselector HP 85685A, S/N 3221A01400, Quasi-Peak Adapter
HP 85650A, S/N 3303A01690 & Preamplifier HP 8449B-OPT H02,
S/N 3008A00372 Cal. 10/17/99
2. Signal Generator: HP 8640B, S/N 2308A21464 Cal. 9/23/99
3. Signal Generator: HP 8614A, S/N 2015A07428 Cal. 5/29/99
4. Passive Loop Antenna: EMCO Model 6512, 9KHz to 30MHz, S/N
9706-1211 Cal. 6/23/97
5. Biconnical Antenna: Eaton Model 94455-1, S/N 1057
6. Log-Periodic Antenna: Electro-Metrics Model EM-6950, S/N 632
7. Dipole Antenna Kit: Electro-Metrics Model TDA-30/1-4, S/N 153
Cal. 11/24/99
8. Double-Ridged Horn Antenna: Electro-Metrics Model RGA-180,
1-18 GHz, S/N 2319 Cal. 4/27/99
9. Horn 40-60GHz: ATM Part #19-443-6R
10. Open Area Test Site #1-3meters Cal. 12/22/99
11. Line Impedance Stabilization Network: Electro-Metrics Model
ANS-25/2, S/N 2604 Cal. 11/30/99
12. Line Impedance Stabilization Network: Electro-Metrics Model
EM-7820, S/N 2682 Cal. 12/1/99
13. Temperature Chamber: Tenney Engineering Model TTRC, S/N 11717-7
14. AC Voltmeter: HP Model 400FL, S/N 2213A14499 Cal. 9/21/99
15. Digital Multimeter: Fluke Model 8012A, S/N 4810047 Cal 9/21/99
16. Digital Multimeter: Fluke Model 77, S/N 43850817 Cal 9/21/99
17. Oscilloscope: Tektronix Model 2230, S/N 300572 Cal 9/23/99
18. Frequency Counter: HP Model 5385A, S/N 3242A07460 Cal 10/6/99

APPLICANT: AUDIOVOX CORPORATION

FCC ID: BGAFR560

REPORT #: T:\CUS\A\AUDIOVOX\191AK0\AUD191A0.RPT

PAGE #: 8